

MODEL **HM-2102 VHF Wattmeter**

HEATHKIT[®]

ASSEMBLY MANUAL

Model HM-2102 VHF Wattmeter



PRICE \$2.00

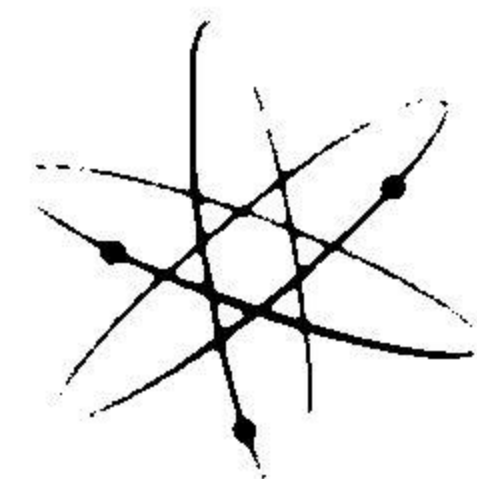

Copyright ©1972
Heath Company
All rights reserved

595-1517-04

HEATH COMPANY PHONE DIRECTORY

The following telephone numbers are direct lines to the departments listed:

Kit orders and delivery information	(616) 982-3411
Credit	(616) 982-3561
Replacement Parts	(616) 982-3571
<i>Technical Assistance:</i>	
R/C, Audio, and Electronic Organs	(616) 982-3310
Amateur Radio	(616) 982-3296
Test Equipment, Strobe Lights, Calculators, Clocks, Weather Instruments	(616) 982-3315
Television	(616) 982-3307
Automotive, Marine, Appliances, Security, General Products	(616) 982-3496



YOUR HEATHKIT 90-DAY FULL WARRANTY

During your first ninety (90) days of ownership, Heath Company will replace or repair free of charge — as soon as practical — any parts which are defective, either in materials or workmanship. You can obtain parts directly from Heath Company by writing us or telephoning us at (616) 982-3571. And we'll pay shipping charges to get those parts to you — anywhere in the world.

We warrant that, during the first ninety (90) days of ownership, our products, when correctly assembled, calibrated, adjusted, and used in accordance with our printed instructions, will meet published specifications.

If a defective part or error in design has caused your Heathkit product to malfunction during the warranty period, through no fault of yours, we will service it free upon delivery at your expense to the Heath factory, Benton Harbor, Michigan, or to any Heathkit Electronic Center (units of Schlumberger Products Corporation), or through any of our authorized overseas distributors.

You will receive free consultation on any problem you might encounter in the assembly or use of your Heathkit product. Just drop us a line or give us a call. Sorry, we cannot accept collect calls.

Our warranty, both express and implied, does not cover damage caused by use of corrosive solder, defective tools, incorrect assembly, misuse, fire, customer-made modifications, flood or acts of God, nor does it include re-imbusement for customer assembly or set-up time. The warranty covers only Heath products and is not extended to non-Heath allied equipment or components used in conjunction with our products or uses of our products for purposes other than as advertised.

And if you are dissatisfied with our service — warranty or otherwise — or our products, write directly to our Director of Customer Services, Heath Company, Benton Harbor, Michigan, 49022. Telephone (616) 982-3524. He'll make certain your problems receive immediate, personal attention.

HEATH COMPANY
BENTON HARBOR, MI. 49022

Assembly
and
Operation
of the



VHF WATTMETER
MODEL HM-2102

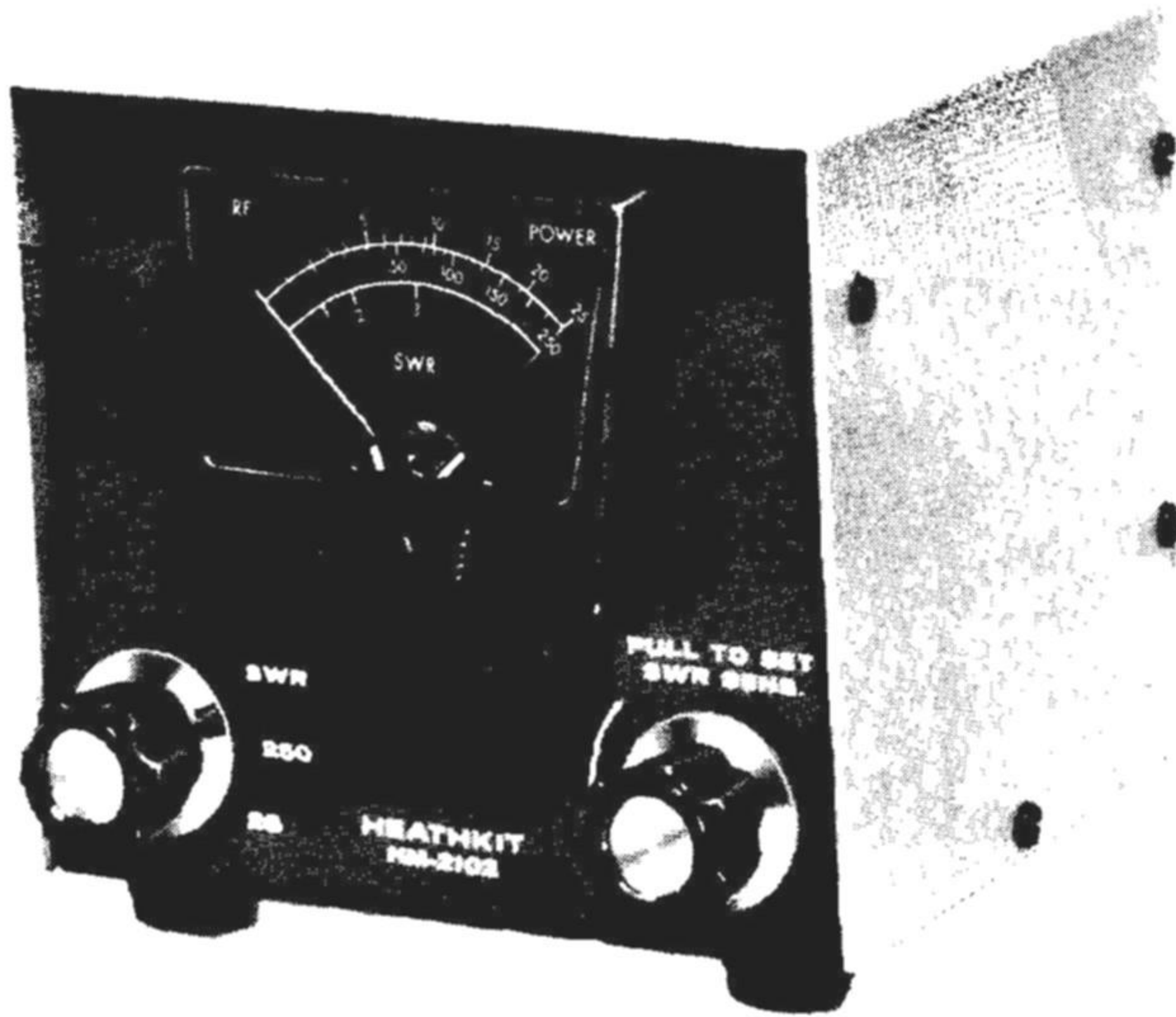

TABLE OF CONTENTS

Introduction	2
Parts List	2
Step-by-Step Assembly	4
Circuit Board Assembly	4
Remote Chassis Assembly	6
Cabinet Assembly and Wiring	7
Adjustment and Calibration	13
Final Assembly	15
Operation	16
In Case of Difficulty	18
Troubleshooting Chart	18
Specifications	19
Circuit Description	20
Circuit Board X-Ray View	20
Schematic	21
Remote Chassis Photograph	22
Cabinet Photograph	22
Warranty	Inside front cover
Customer Service	Inside rear cover

HEATH COMPANY
BENTON HARBOR, MICHIGAN 49022



INTRODUCTION

The Heathkit Model HM-2102 VHF Wattmeter is a reliable instrument for measuring the forward and reflected RF power of a radio transmitting system in the 50 to 160 MHz VHF range.

When the Function switch is set to the 25 watt or the 250 watt position, the maximum forward power indicated on the meter helps you to tune your transmitter for maximum efficiency. When the switch is set at the SWR setting, the Wattmeter measures the reflected power and indicates on the SWR scale the mismatch between the transmission line and the load (antenna). This information is also valuable for antenna adjustments or to determine the frequency range of

the antenna. The circuitry includes an internal calibration facility for 2-meter and 6-meter bands.

This Wattmeter may be permanently installed in your transmission line and needs no other power source. The unit gives negligible insertion loss, however, it is designed only for a transmission line of a 50 Ω nominal characteristic impedance. The small cabinet is designed for use at your operating position, but for convenience the detector portion may be removed and mounted nearby.

Read the "Kit Builders Guide" for complete information on unpacking, parts identification, tools, wiring, soldering and step-by-step assembly procedures.

PARTS LIST

Check each part against the following list. The key numbers correspond to the numbers in the Parts Pictorial (fold-out from Page 3). To order replacement parts: Use the Parts Order Form furnished with this kit. If one is not available, refer to "Replacement Parts" inside the rear cover of the Manual.



KEY PART No.	PARTS No.	PARTS Per Kit	DESCRIPTION	PRICE Each	KEY PART No.	PARTS No.	PARTS Per Kit	DESCRIPTION	PRICE Each
RESISTORS					Other				
1/2-Watt					A2	1-43-1	1	51 Ω , 1-watt (green-brown-black)	.20
A1	1-157	2	470 Ω (yellow-violet-brown)	.15	A3	2-50	1	10 k Ω precision	1.00
A1	1-44	1	2200 Ω (red-red-red)	.15	A4	10-325	1	50 k Ω control	1.00
A1	1-105	1	10 k Ω (brown-black-orange)	.15	A5	19-153	1	200 k Ω control with switch (appearance may vary)	2.75
A1	1-50	1	68 k Ω (blue-gray-orange)	.15					

KEY PART		PARTS	DESCRIPTION	PRICE	KEY PART		PARTS	DESCRIPTION	PRICE
No.	No.	Per Kit		Each	No.	No.	Per Kit		Each
CAPACITORS					METAL PARTS				
A6	20-130	1	12 pF mica	.25	D1	90-503-1	1	Cabinet top	1.80
A6	20-148	2	100 pF mica	.30	D2	90-504-2	1	Cabinet chassis	1.65
A7	21-181	1	7.7 pF disc	.40	D3	214-116	1	Remote chassis cover	2.10
A7	21-3	1	10 pF disc	.15	D4	214-172-1	1	Remote chassis	4.65
A7	21-6	2	27 pF disc	.15	D5	204-135	1	Short bracket	.15
A7	21-140	4	.001 μ F disc	.15	D6	204-363	1	Long bracket	.30
A7	21-27	2	.005 μ F disc	.15	D7	205-778	1	Alignment tool blade	.15
A8	28-3	1	.56 pF phenolic (green-blue-gray)	.15	MISCELLANEOUS				
A9	21-41	1	14 pF disc (brown-yellow-black)	.20	E1	75-30	1	Strain relief	.15
A10	31-57	1	2.7-20 pF trimmer	1.05		85-1443-2	1	Circuit board	2.05
INDUCTORS-DIODE-SWITCH					E2	207-5	1	Cable clamp	.15
B1	40-1628	1	Toroid coil	1.30	E3	261-9	4	Rubber foot	.05
B2	56-20	3	1N295 diode (red-white-green)	.40	E4	407-179	1	Meter	21.65
B3	63-47	1	3-position switch	1.40	E5	432-120	1	Female connector	.15
B4	475-10	5	Ferrite bead	.15	E6	432-121	2	Connector pin	.15
HARDWARE					E7	462-191	2	Knob	1.25
NOTE: C1 through C14 are shown actual size.						340-3	1	Bare wire	.05/ft
#4 Hardware						346-21	1	Teflon* sleeve	.35/ft
C1	250-213	8	4-40 x 5/16" screw	.05		347-39	1	Cable	.15/ft
C2	252-2	8	4-40 nut	.05		490-5	1	Nut starter	.15
C3	254-9	8	#4 lockwasher	.05		391-34	1	Blue and white label	
#6 Hardware						597-260	1	Parts Order Form	
C4	250-170	8	#6 x 1/4" sheet metal screw	.05		597-308	1	Kit Builders Guide	
C4	250-369	8	#6 x 1/4" black screw	.05			1	Assembly Manual (See front cover for part number.)	2.00
C5	250-89	4	6-32 x 3/8" screw	.05	Solder (Additional 3' rolls of solder, #331-6, can be ordered for 25 cents each.)				
C6	250-162	5	6-32 x 1/2" screw	.05	*Dupont Registered Trademark				
C7	252-3	11	6-32 nut	.05	The above prices apply only on purchases from the Heath Company where shipment is to a U.S.A. destination. Add 10% (minimum 25 cents) to the price when ordering from a Heathkit Electronic Center to cover local sales tax, postage, and handling. Outside the U.S.A. parts and service are available from your local Heathkit source and will reflect additional transportation, taxes, duties, and rates of exchange.				
C8	253-89	1	#6 D washer	.05					
C9	254-1	12	#6 lockwasher	.05					
C10	259-1	1	#6 solder lug	.05					
Other Hardware									
C11	250-43	2	#8 setscrew	.05					
C12	252-7	2	Control nut	.05					
C13	253-10	2	Control flat washer	.05					
C14	254-35	1	Control lockwasher	.20					
C15	255-30	1	Control spacer	.15					
C16	255-2	1	Small spacer	.05					
C17	257-12	1	Eyelet	.05					
C18	436-5	2	Coaxial connector	.85					

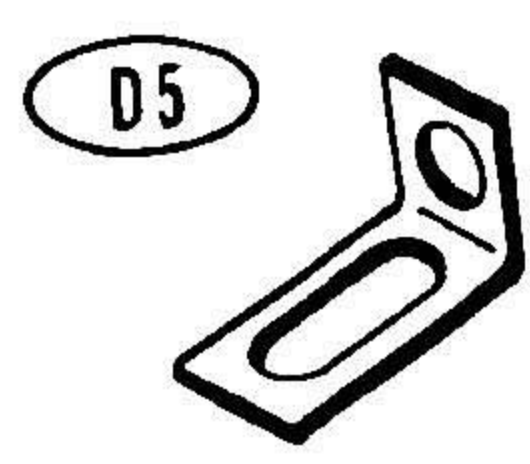
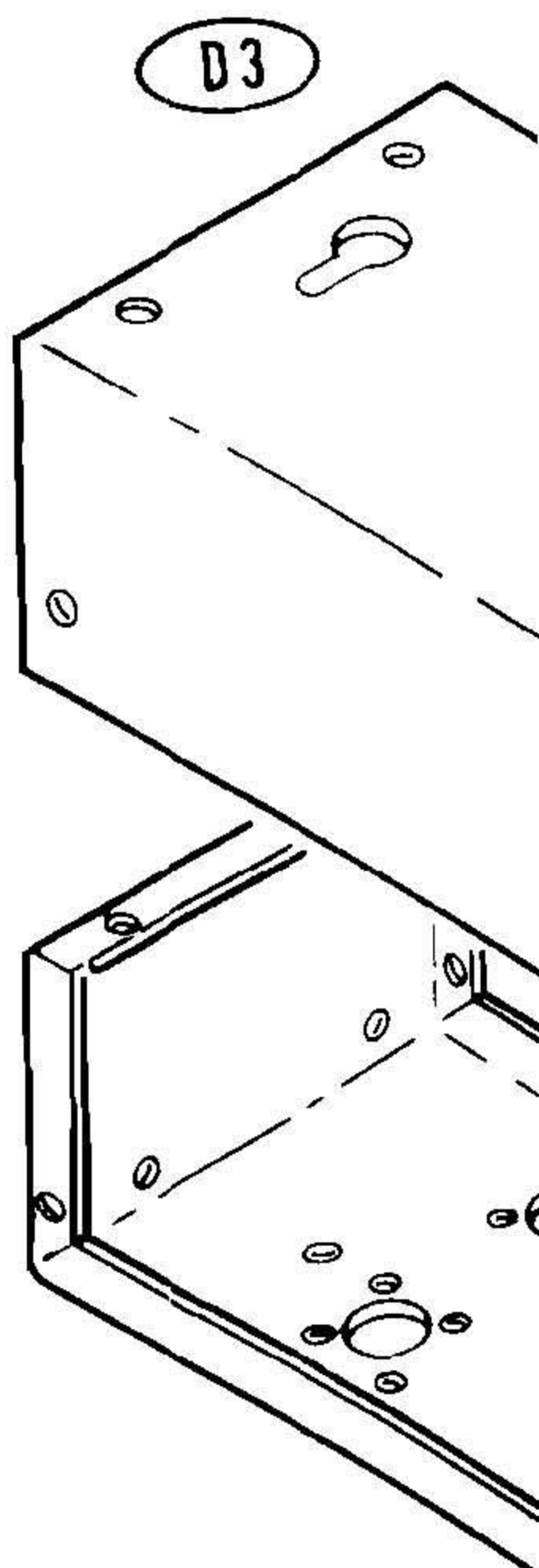
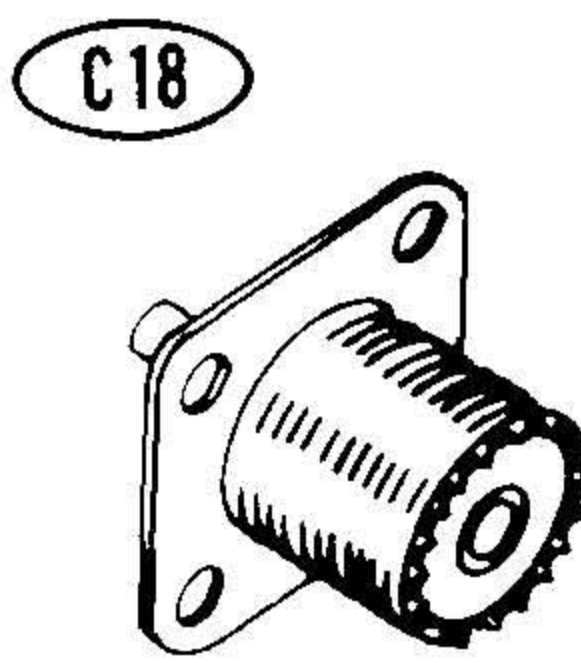
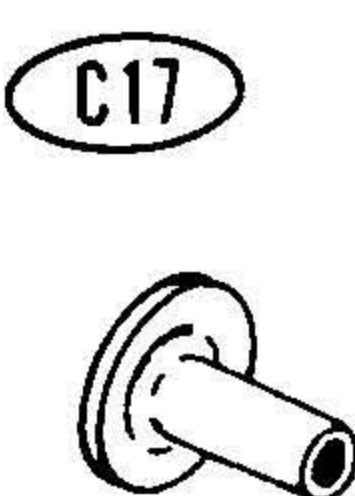
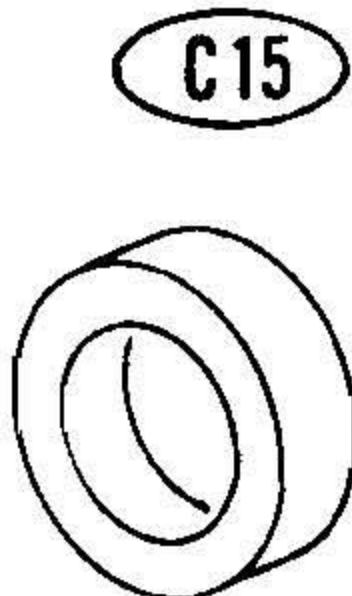
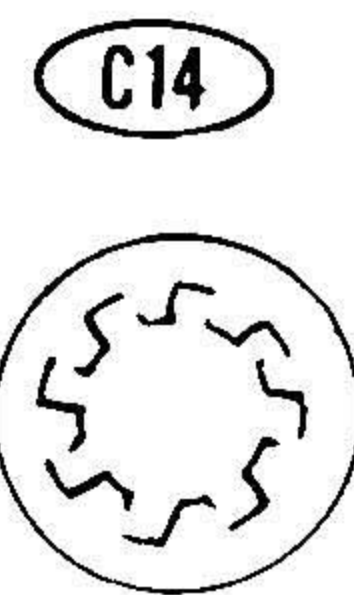
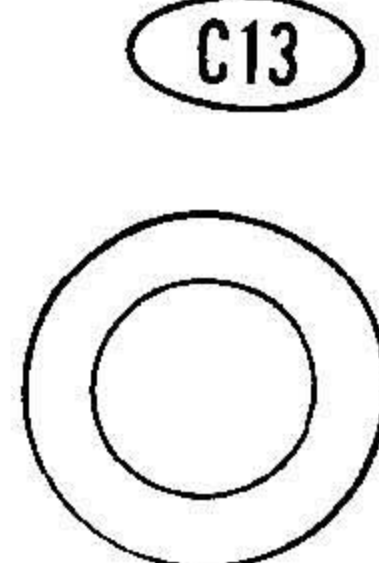
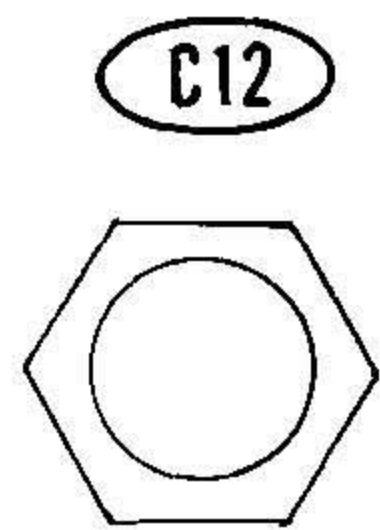
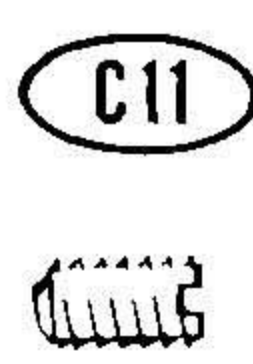
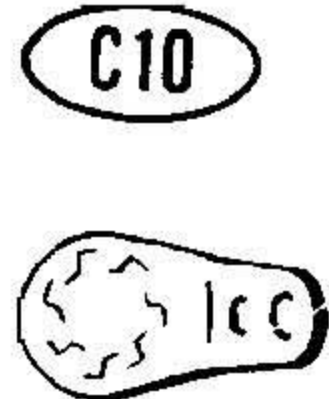
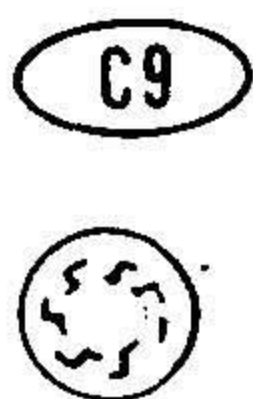
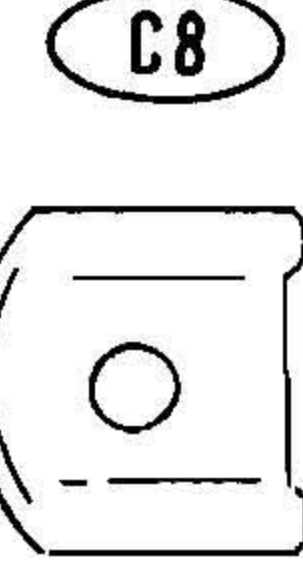
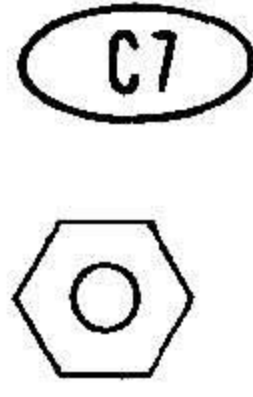
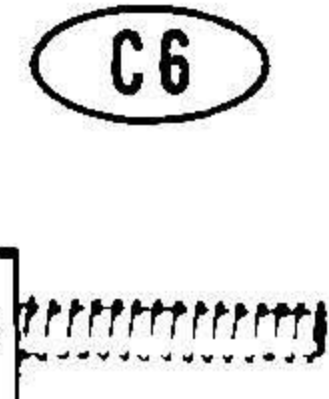
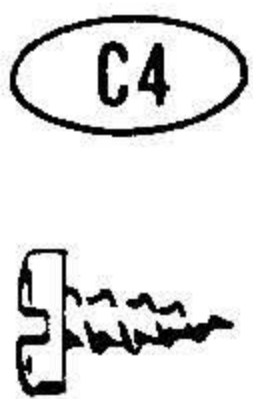
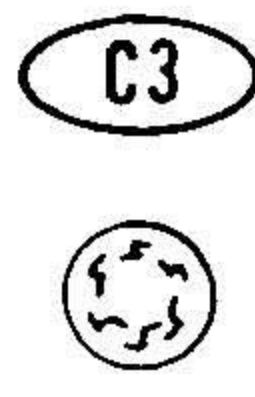
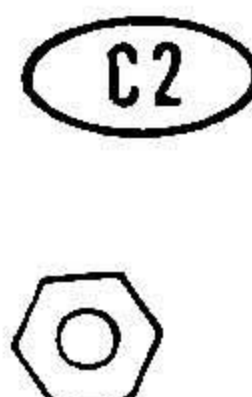
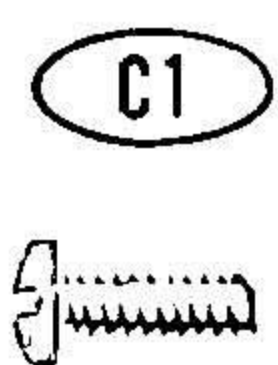
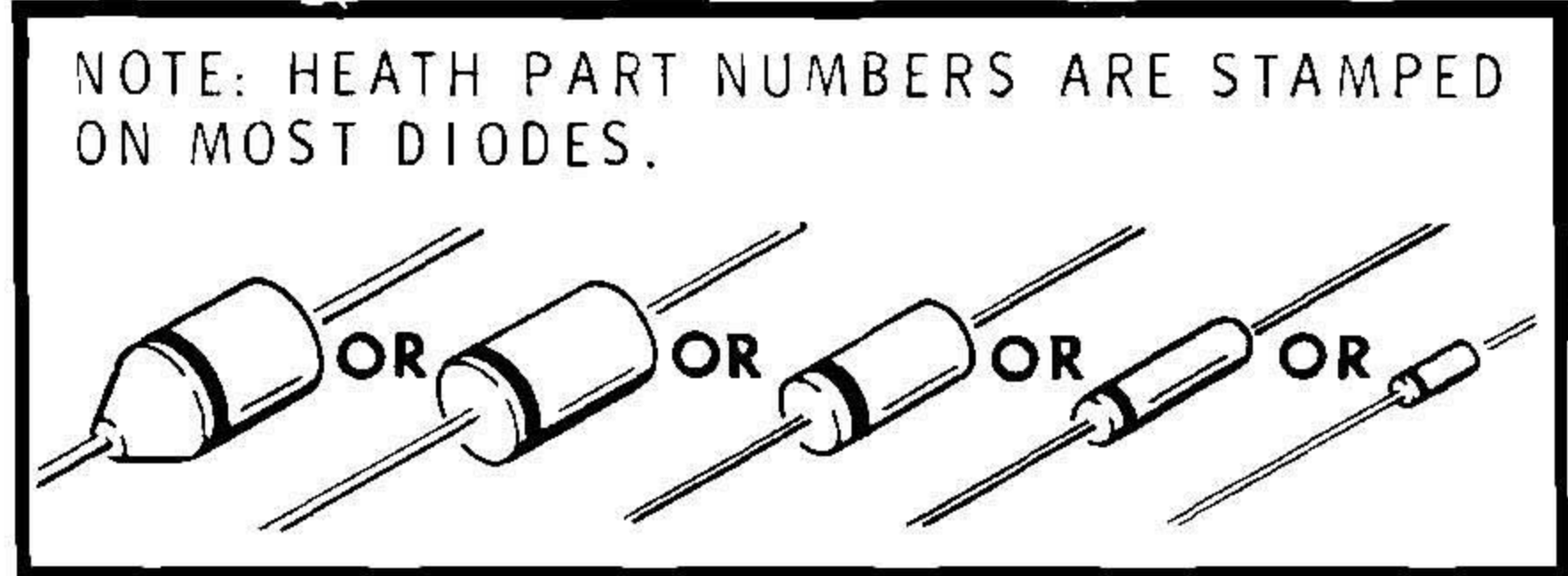
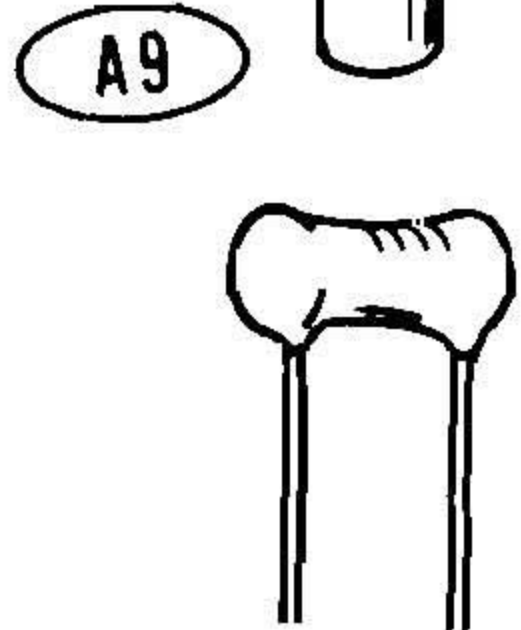
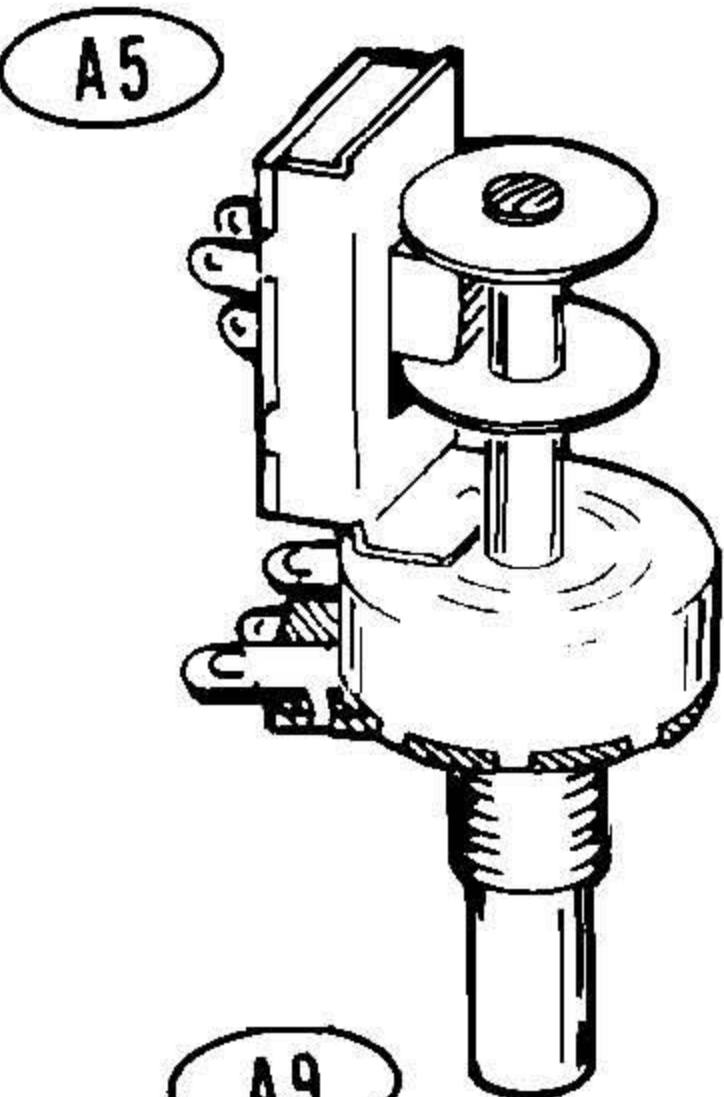
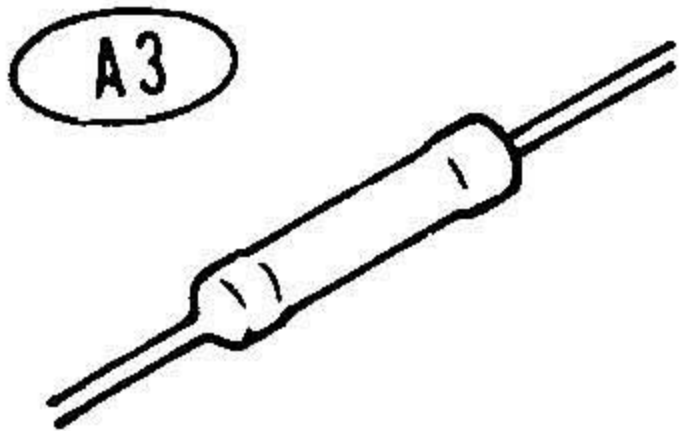
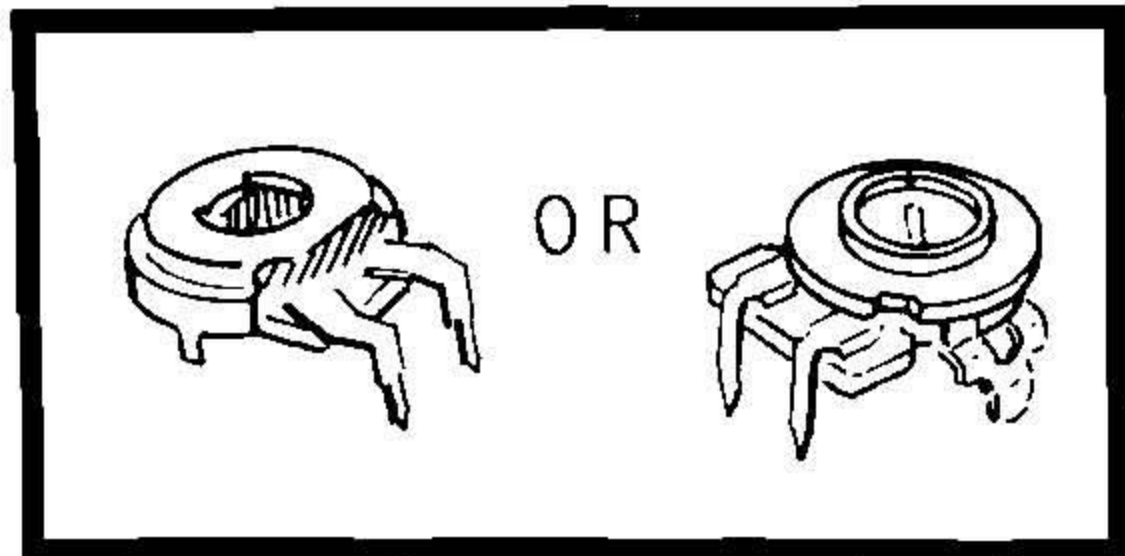
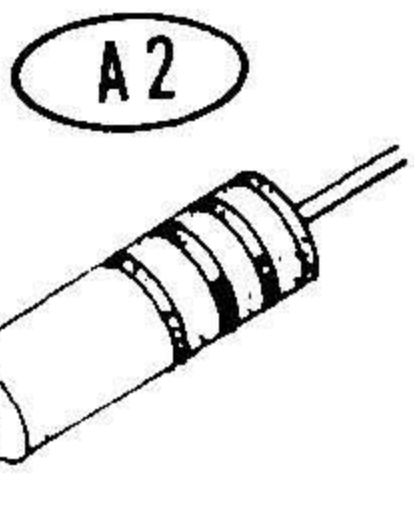
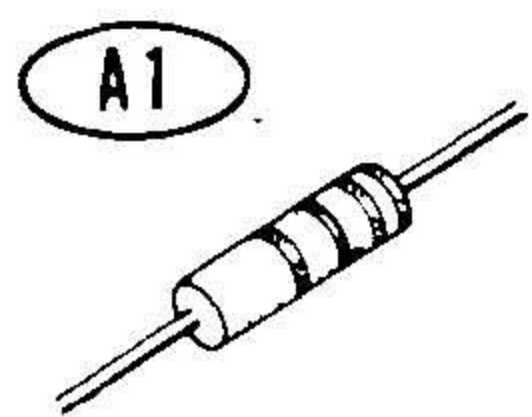

PARTS PICTORIAL

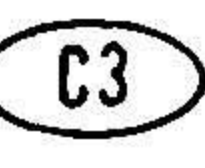

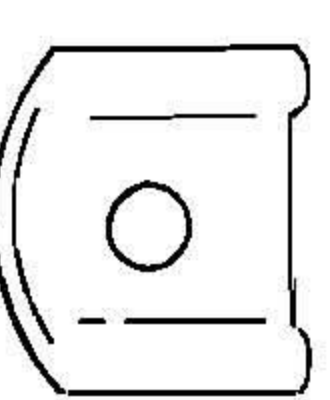
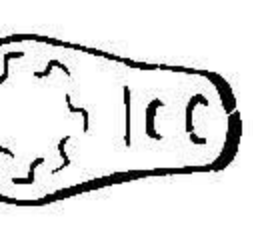
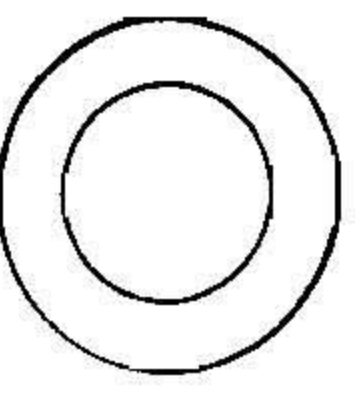
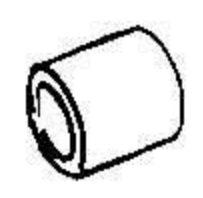
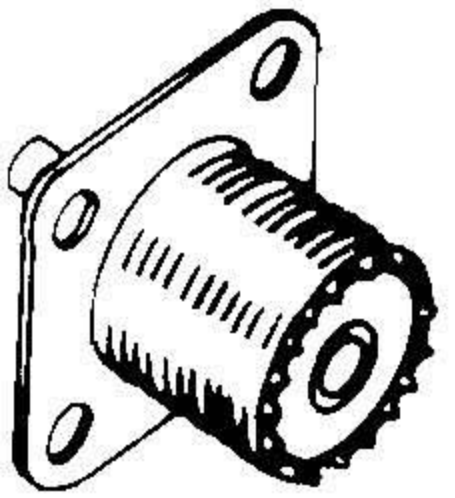
PARTS PICTORIAL

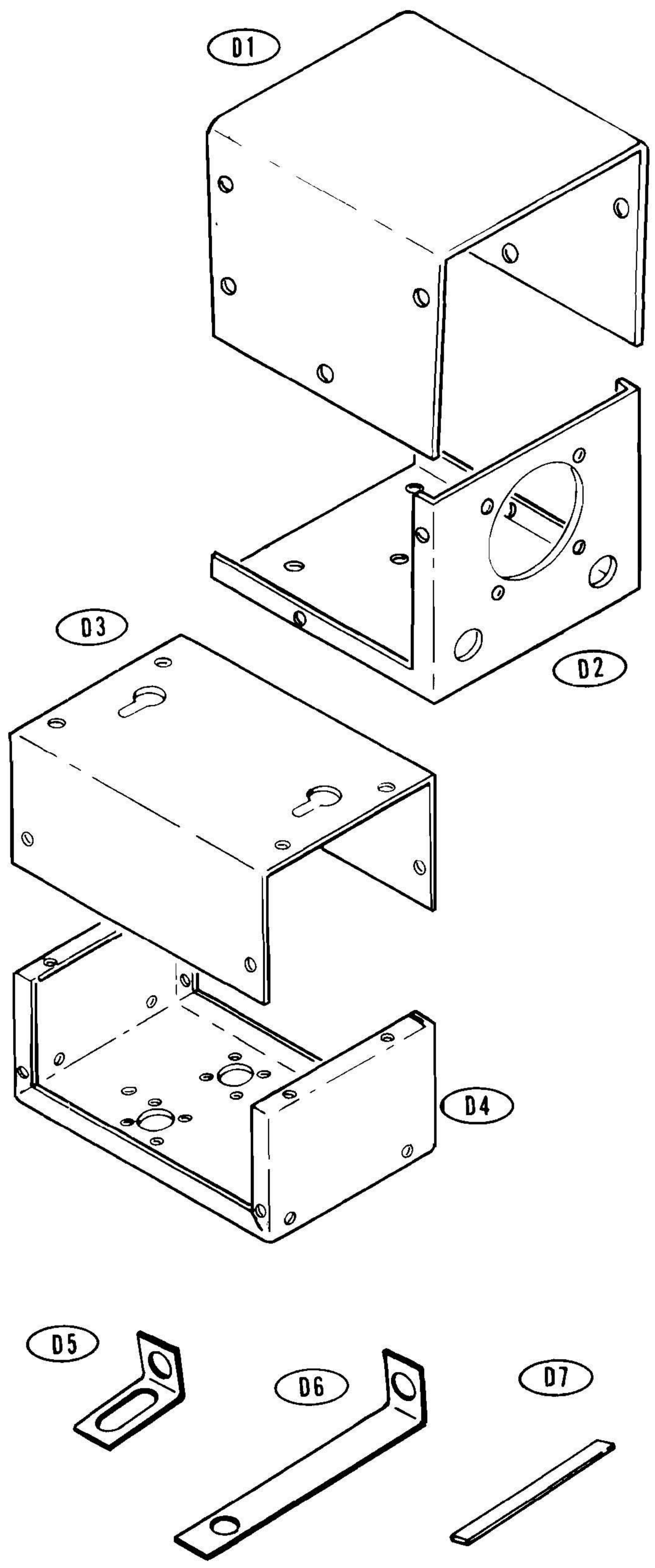
- C3 
- C6 
- C8 
- C10 
- C13 
- C16 
- 18 

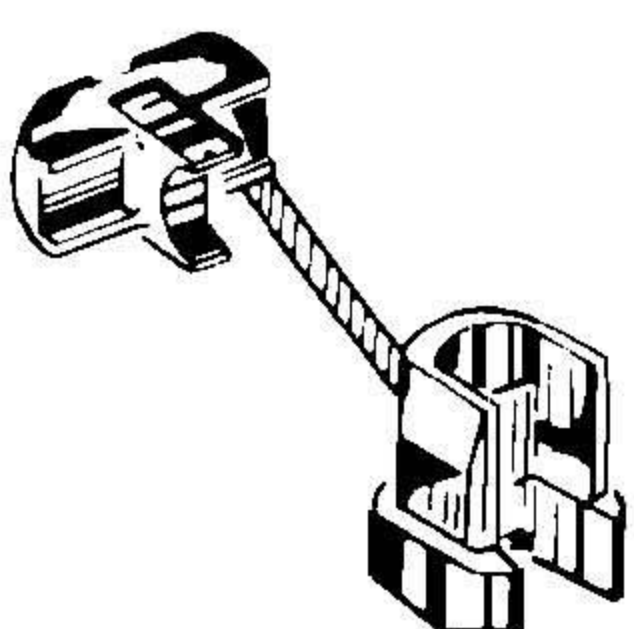

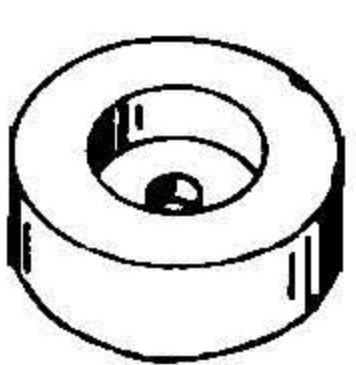
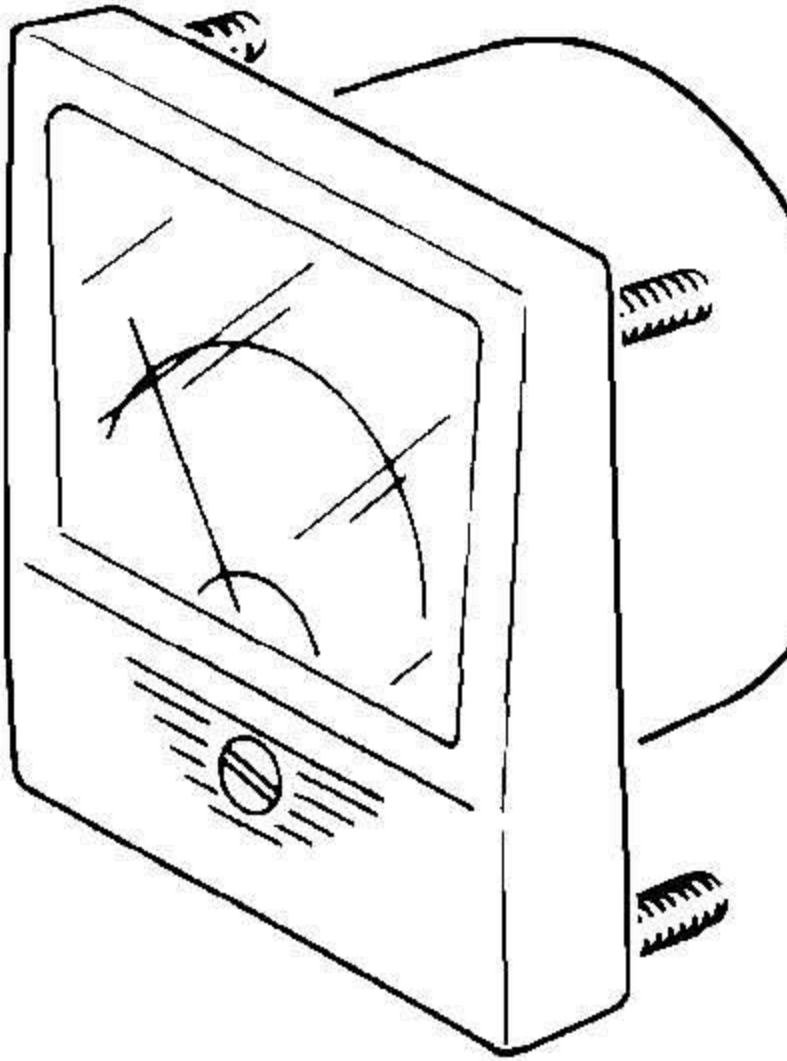
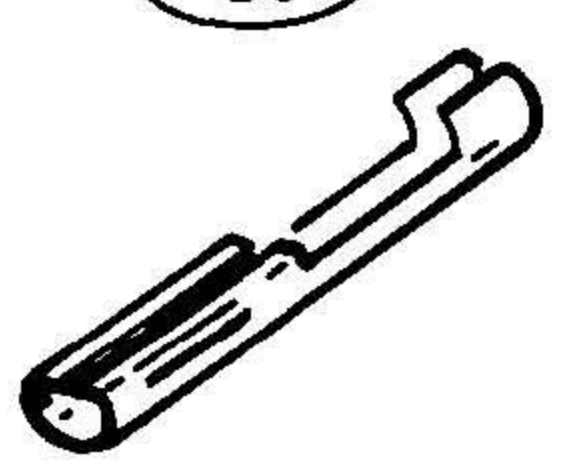
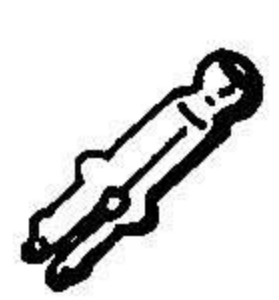
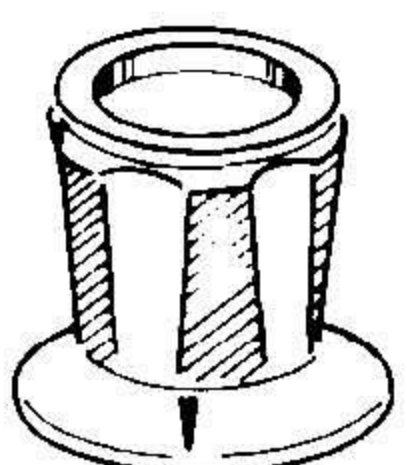
- E1 
- E2 
- E3 
- E4 
- E5 
- E6 
- E7 

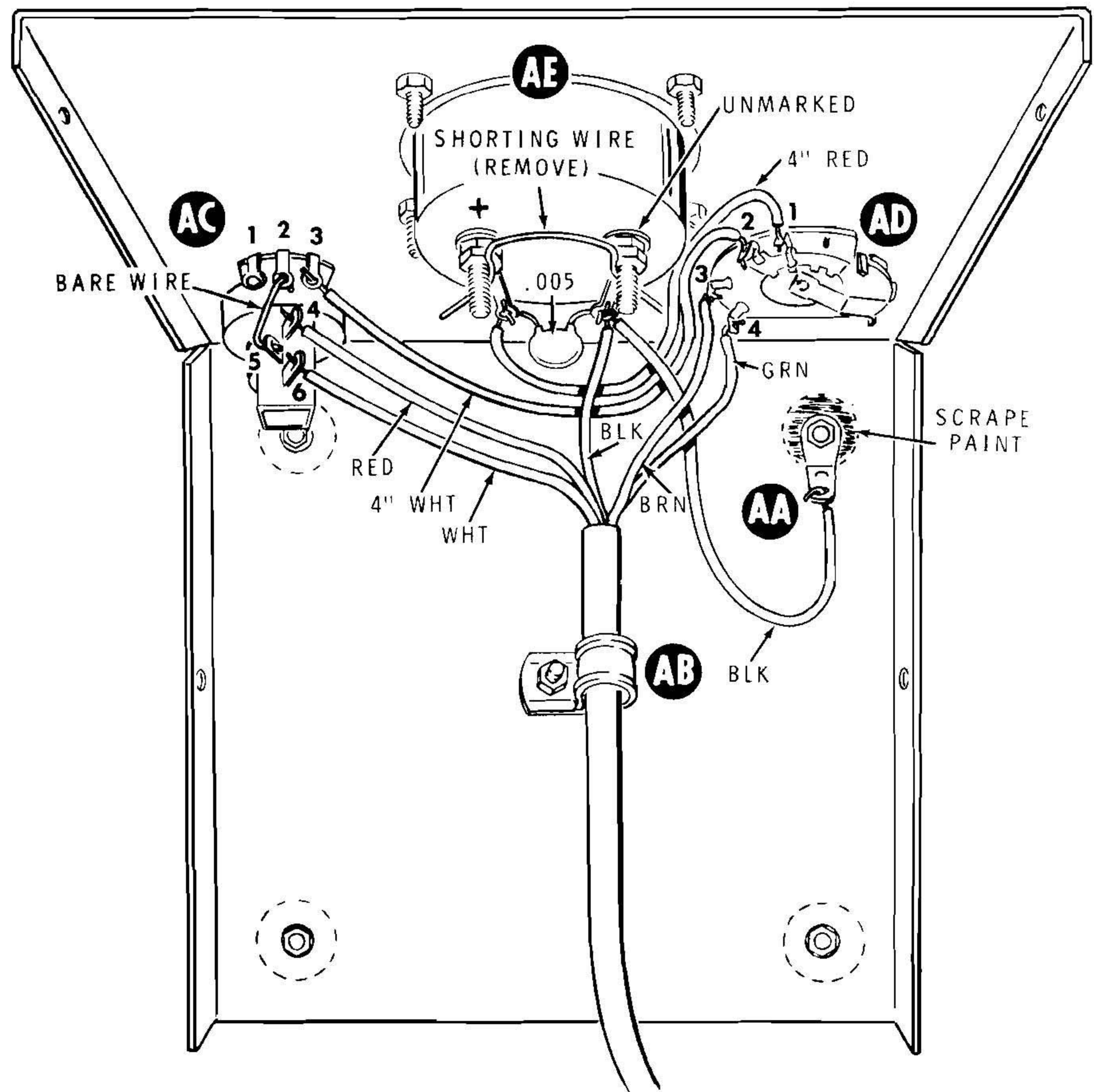

PICTORIAL 4

STEP-BY-STEP ASSEMBLY

Before you start the "Circuit Board Assembly," be sure to read the "Circuit Board Parts Mounting" and "Soldering" sections of the "Kit Builders Guide."

All resistors will be called out by resistance values (in Ω or $k\Omega$); the color code will also be given for all except the precision resistor. Capacitors will be called out by capacitance value (in pF or μF) and type (mica or disc).

CIRCUIT BOARD ASSEMBLY

Components will be installed on the circuit board by following the steps on Pages 4 and 5. Position all parts as shown in the Pictorials. Follow the instructions carefully and read the entire step before performing the operation.

Locate the circuit board and position it lettered side up as shown in Pictorial 1. Then complete each step on Pictorials 1 and 2.

CONTINUE

START

NOTE: DIODES MAY BE SUPPLIED IN ANY OF THE FOLLOWING SHAPES. ALWAYS POSITION THE BANDED END AS SHOWN ON THE CIRCUIT BOARD.

() 1N295 diode (red-white-green) at D1 (#56-20).

() 1N295 diode (red-white-green) at D2 (#56-20).

() 1N295 diode (red-white-green) at D3 (#56-20).

() 2200 Ω (red-red-red).

() 470 Ω (yellow-violet-brown).

SAFETY WARNING: Avoid eye injury when you clip off excess leads. We suggest that you wear glasses, or at least clip the leads so the ends will not fly toward your eyes.

() Solder all leads to the foil and cut off the excess lead lengths.

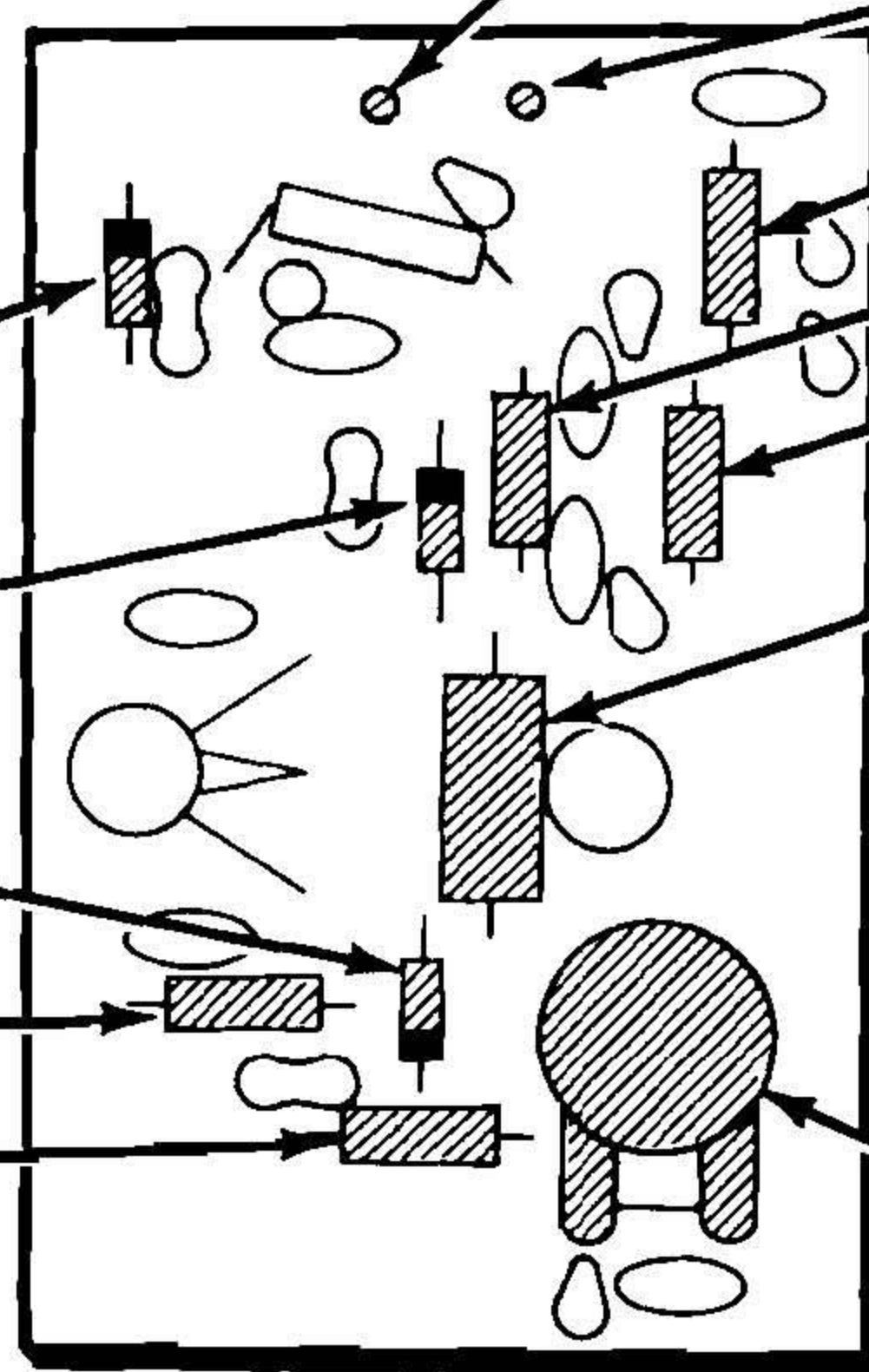

PICTORIAL 1

() Install a connector pin in the circuit board as shown.

() Connector pin.

() 68 $k\Omega$ (blue-gray-orange).

() 470 Ω (yellow-violet-brown).

() 10 $k\Omega$ (brown-black-orange).

() 51 Ω , 1-watt (green-brown-black). Position clear of circle.

FOR GOOD SOLDERED CONNECTIONS, YOU MUST KEEP THE SOLDERING IRON TIP CLEAN... WIPE IT OFTEN WITH A DAMP SPONGE OR CLOTH.

() Solder all leads and connector pins to the foil and cut off the excess lead lengths.

() Install the 50 $k\Omega$ control as shown. Solder the four lugs to the foil.

START

NOTE: Before you install ceramic capacitors, remove any insulation from the leads as shown.

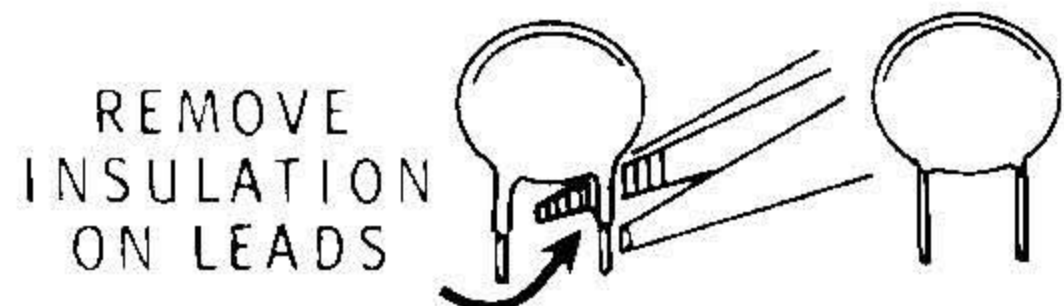

() .001 μ F disc.

() .001 μ F disc.

() .001 μ F disc.

() .005 μ F disc.

NOTE: In the following step, install the 12 pF capacitor for a 2-meter built-in calibrator. Otherwise, use the 14 pF capacitor. See Power Meter Calibration on Page 14.

() 12 pF mica or 14 pF disc at C2.

() 100 pF mica.

() 27 pF disc.

() 27 pF disc.

() 100 pF mica.

() .001 μ F disc.

() Solder the leads to the foil and cut off the excess lead lengths. NOTE: Save one of the excess lead lengths for use in later steps.

() Refer to Detail 2A and install the .56 pF phenolic (green-blue-gray). Position this capacitor vertically against the circuit board as shown. The free end will be connected later.

() 10 k Ω precision. Position it as shown.

() Solder the leads to the foil and cut off the excess lead lengths.

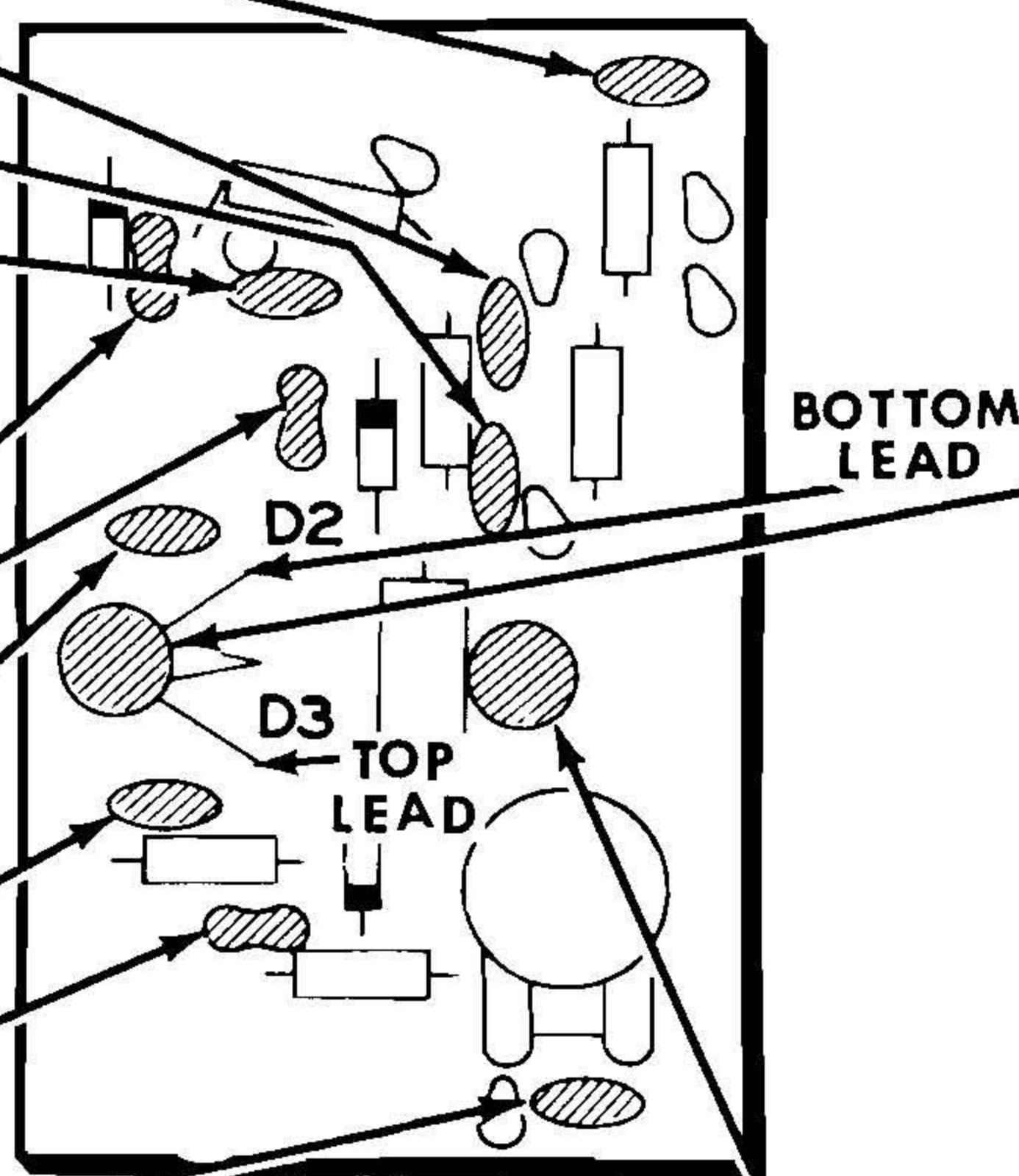

PICTORIAL 2

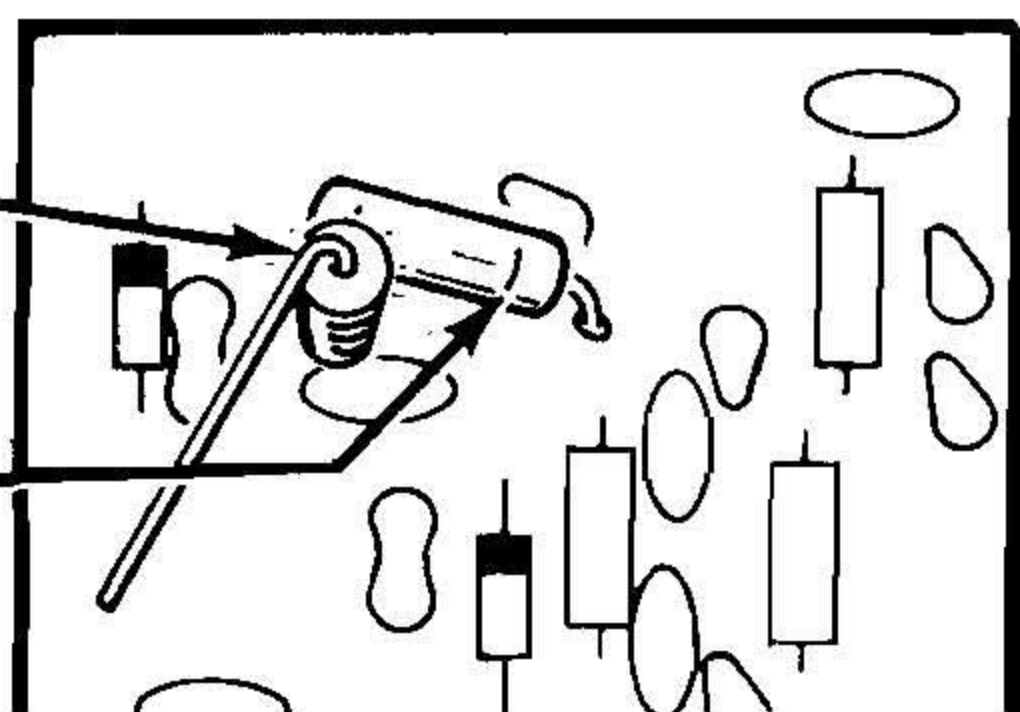

Detail 2A

CONTINUE

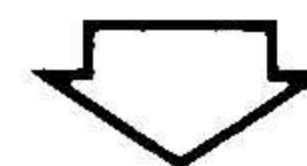

() Install the toroid coil as follows:

1. Position the three toroid coil leads as shown, and push the leads through the circuit board. NOTE: Be sure the twisted pair of leads goes into the center hole. The lead coming from the top of the coil must go to the hole nearest D3, and the lead from the bottom must go to the hole nearest D2.
2. Carefully push an eyelet through the center of the toroid coil. Do not force the eyelet. Then push the eyelet through the circuit board and solder it to the foil.

NOTE: If an ohmmeter is available, check between the eyelet and one of the coil leads to be sure they are insulated.

3. Solder the tinned ends of the three leads to the foil and remove any excess lead lengths.

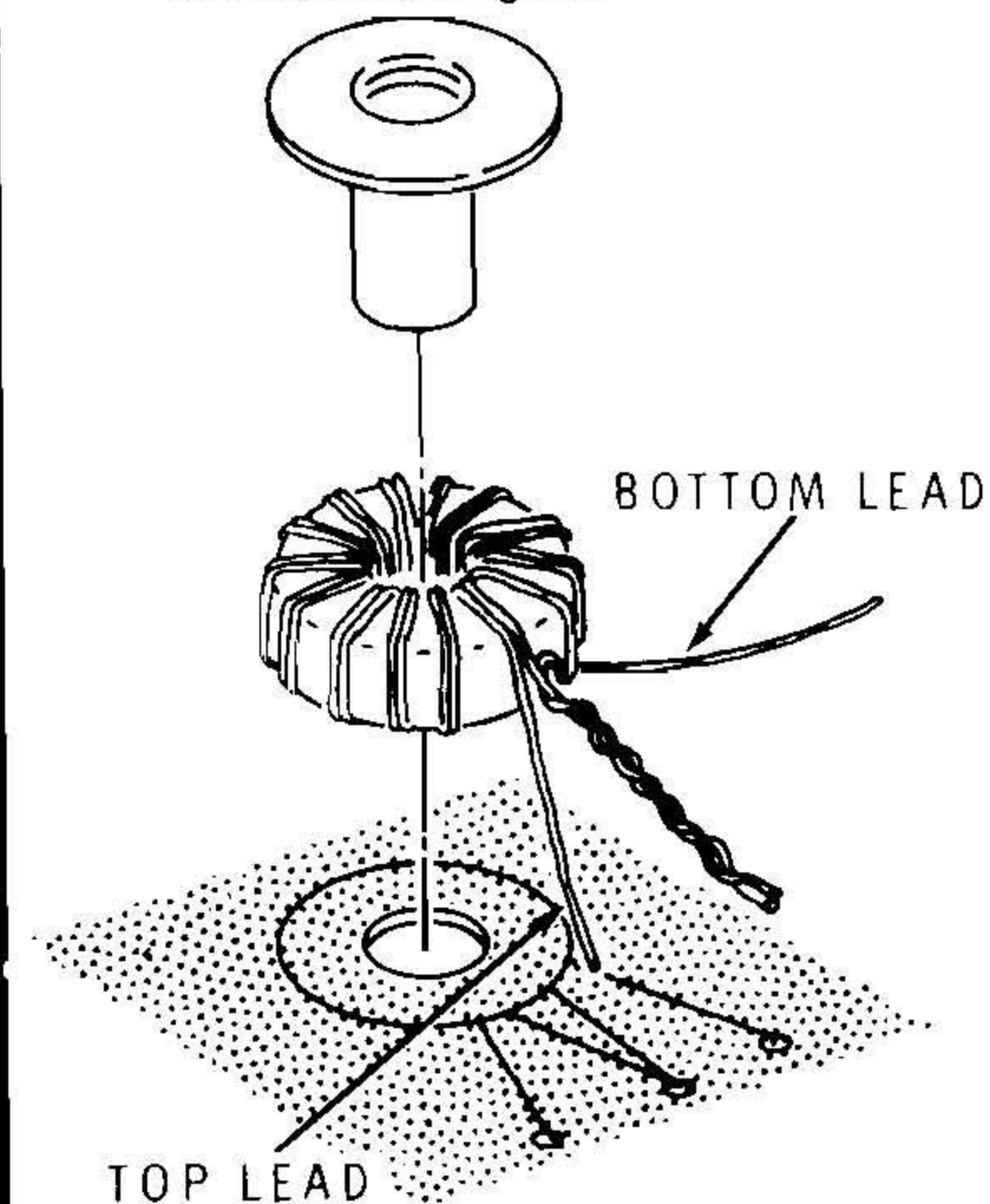

() Install the 2.7-20 pF trimmer as shown. Solder the three lugs to the foil.

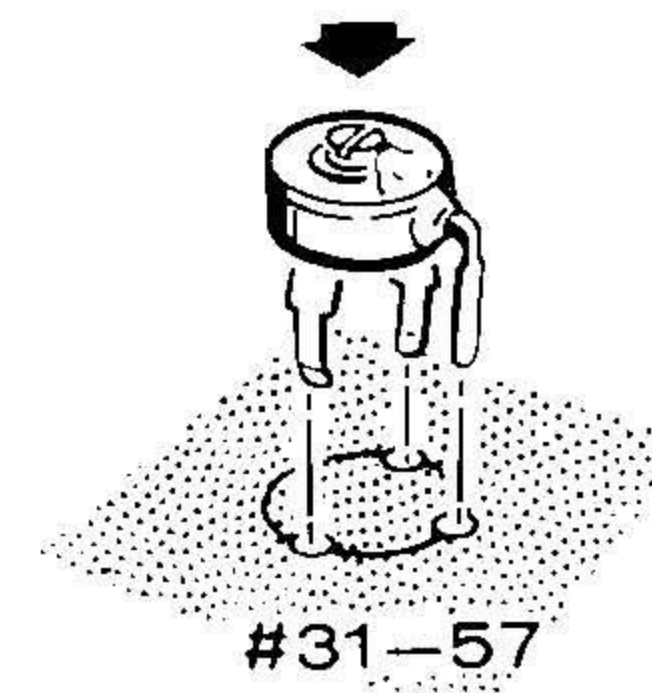

Temporarily set the circuit board aside.

FINISH

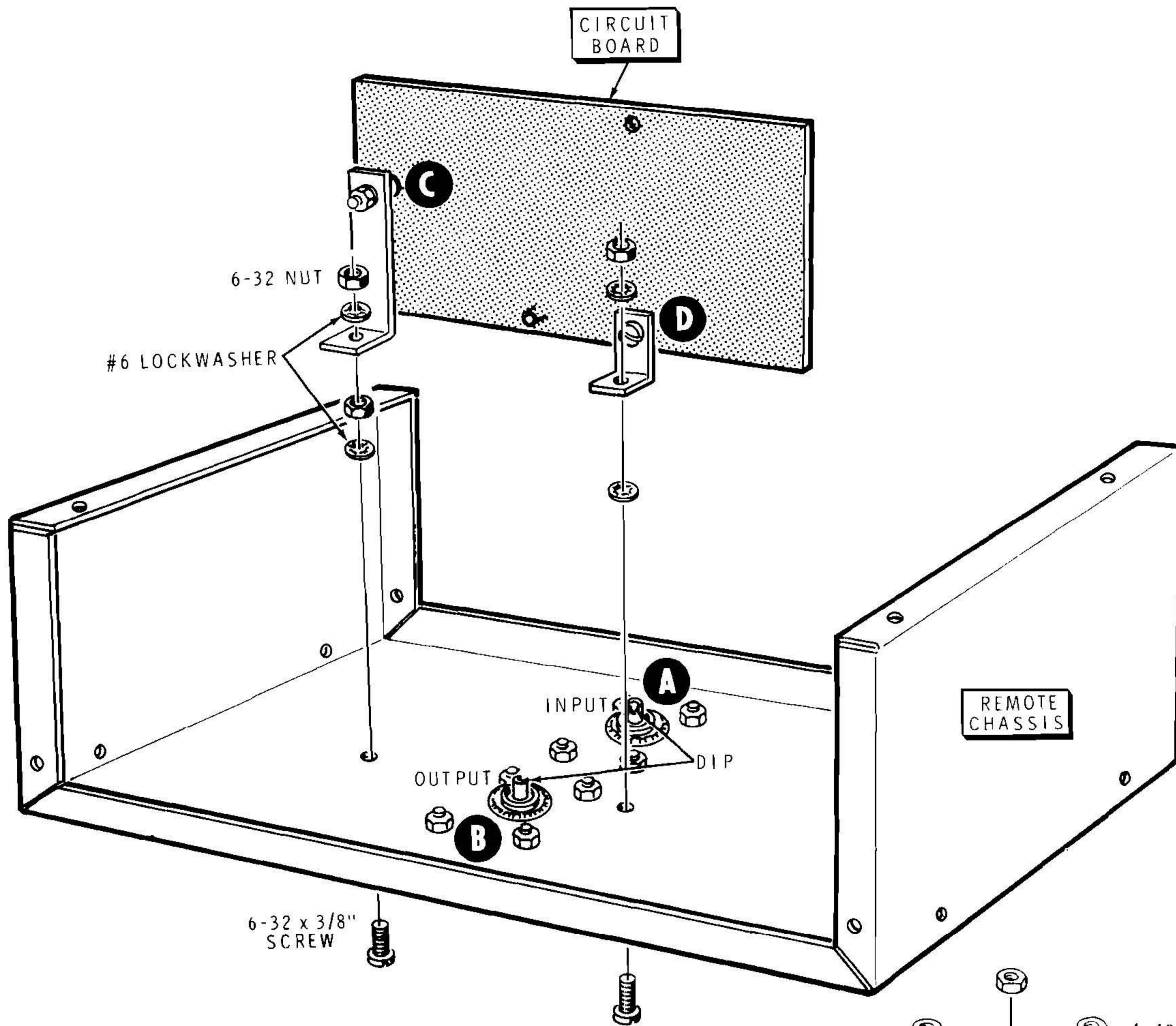

PICTORIAL 3

REMOTE CHASSIS ASSEMBLY

Refer to Pictorial 3 for the following steps.

NOTE: The Heath Company has provided a plastic nut starter with this kit. Use this nut starter to hold and start 4-40 and 6-32 nuts on screws.

- () Mount a coaxial connector on the outside of the remote chassis at A. Use four 4-40 x 5/16" screws, four #4 lockwashers, and four 4-40 nuts as shown in Detail 3A. Position the center pin dip toward the other mounting hole.
- () In a similar manner, mount a coaxial connector at B.

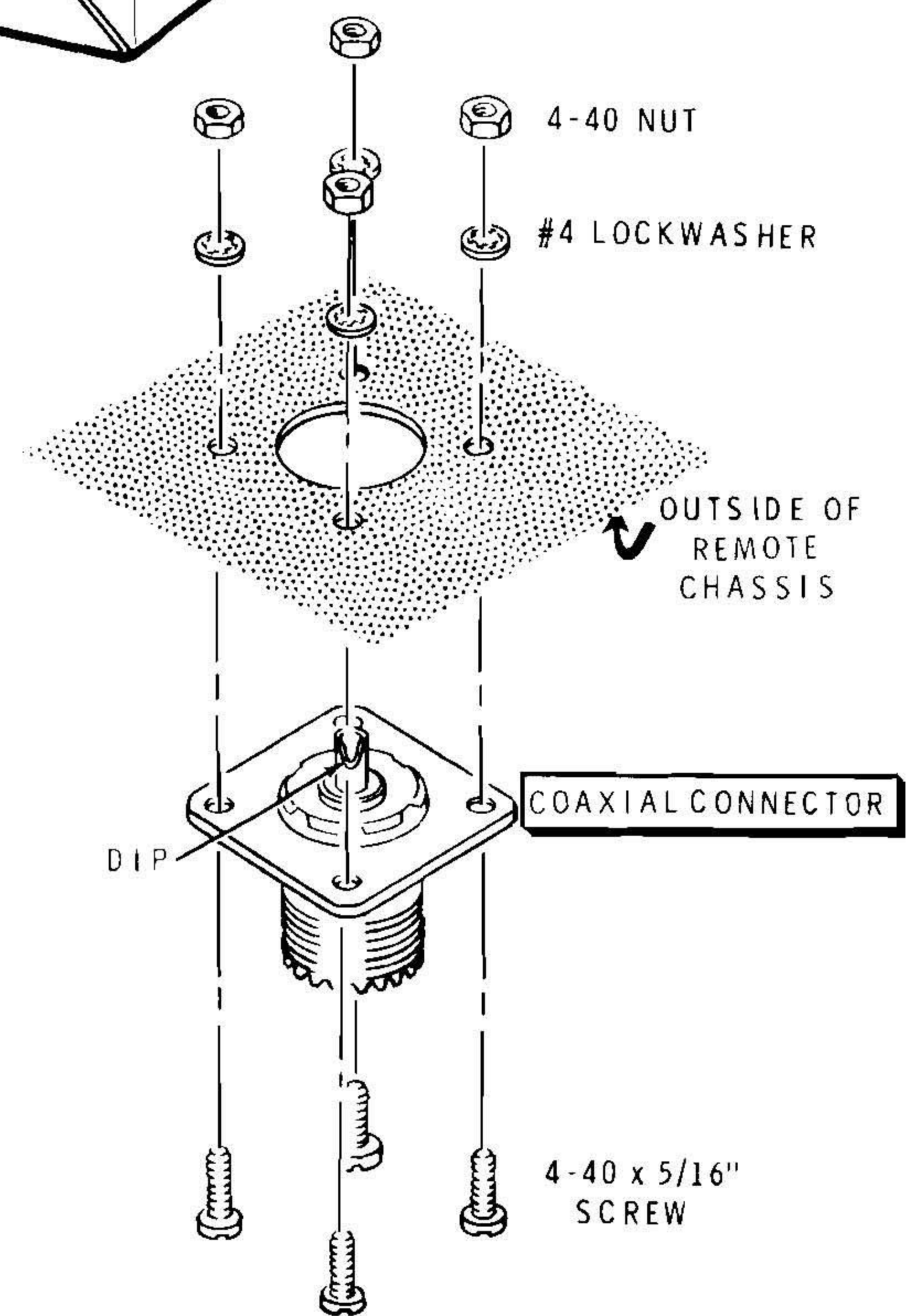

Detail 3A

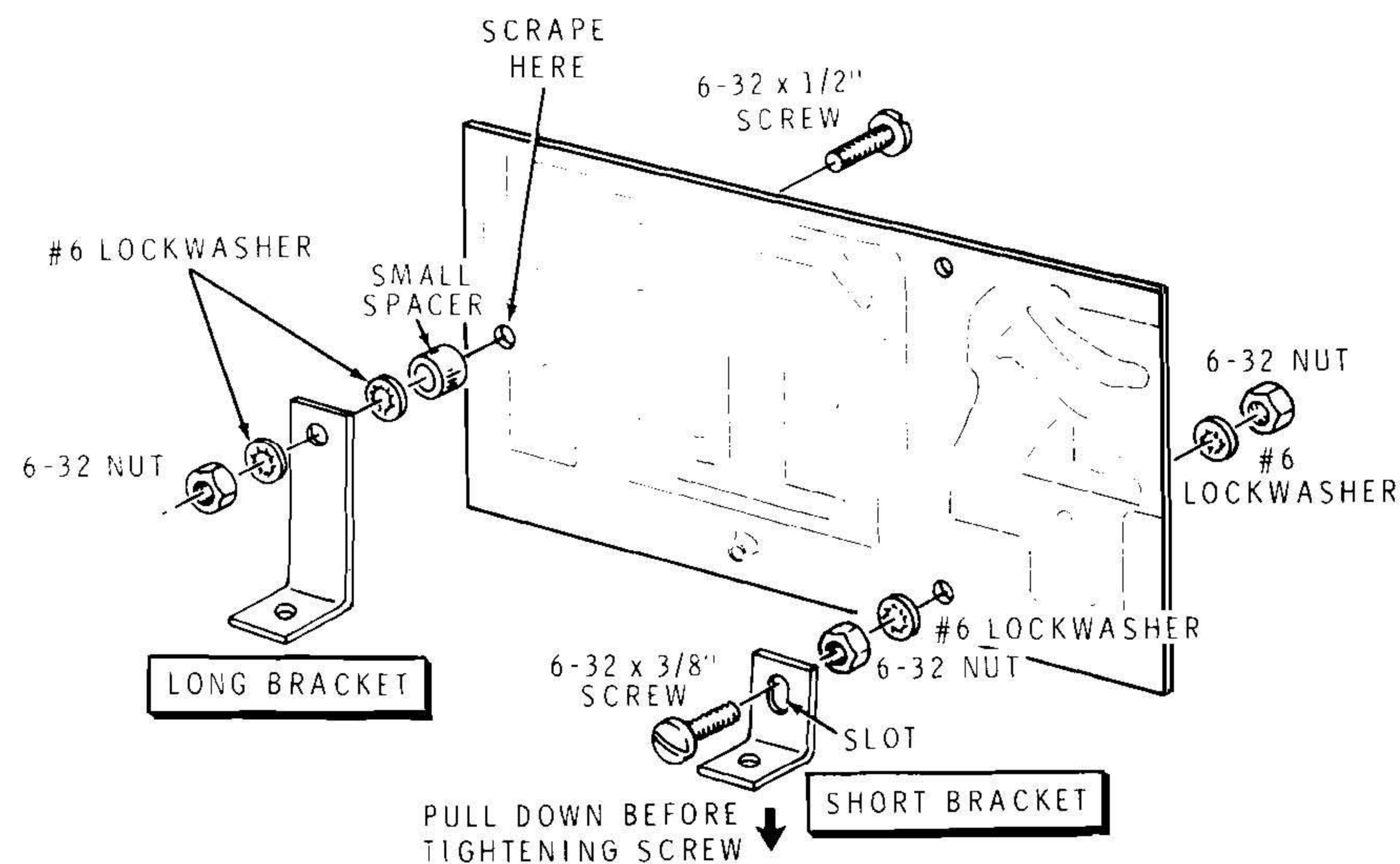

Detail 3B

- () In the next step, you will mount the long bracket to the circuit board. Therefore, scrape away the colored protective coating from the foil where the small spacer will contact it.
- () Mount a long bracket on the circuit board at C as shown in Detail 3B. Use a 6-32 x 1/2" screw, two #6 lockwashers, a small spacer, and a 6-32 nut.
- () Mount a short bracket on the circuit board at D with a 6-32 x 3/8" screw, two #6 lockwashers, and two 6-32 nuts. Position the slotted hole as shown. Pull the bracket down as far as it will go, as shown, before tightening the screws.
- () Mount the circuit board in the center of the remote chassis as shown in Pictorial 3. Use a 6-32 x 3/8" screw, two #6 lockwashers, and two 6-32 nuts on bracket C. Then mount bracket D with a 6-32 x 3/8" screw, two #6 lockwashers and a 6-32 nut.

CABINET ASSEMBLY AND WIRING

Refer to Pictorial 4 (fold-out from Page 4) for the following steps.

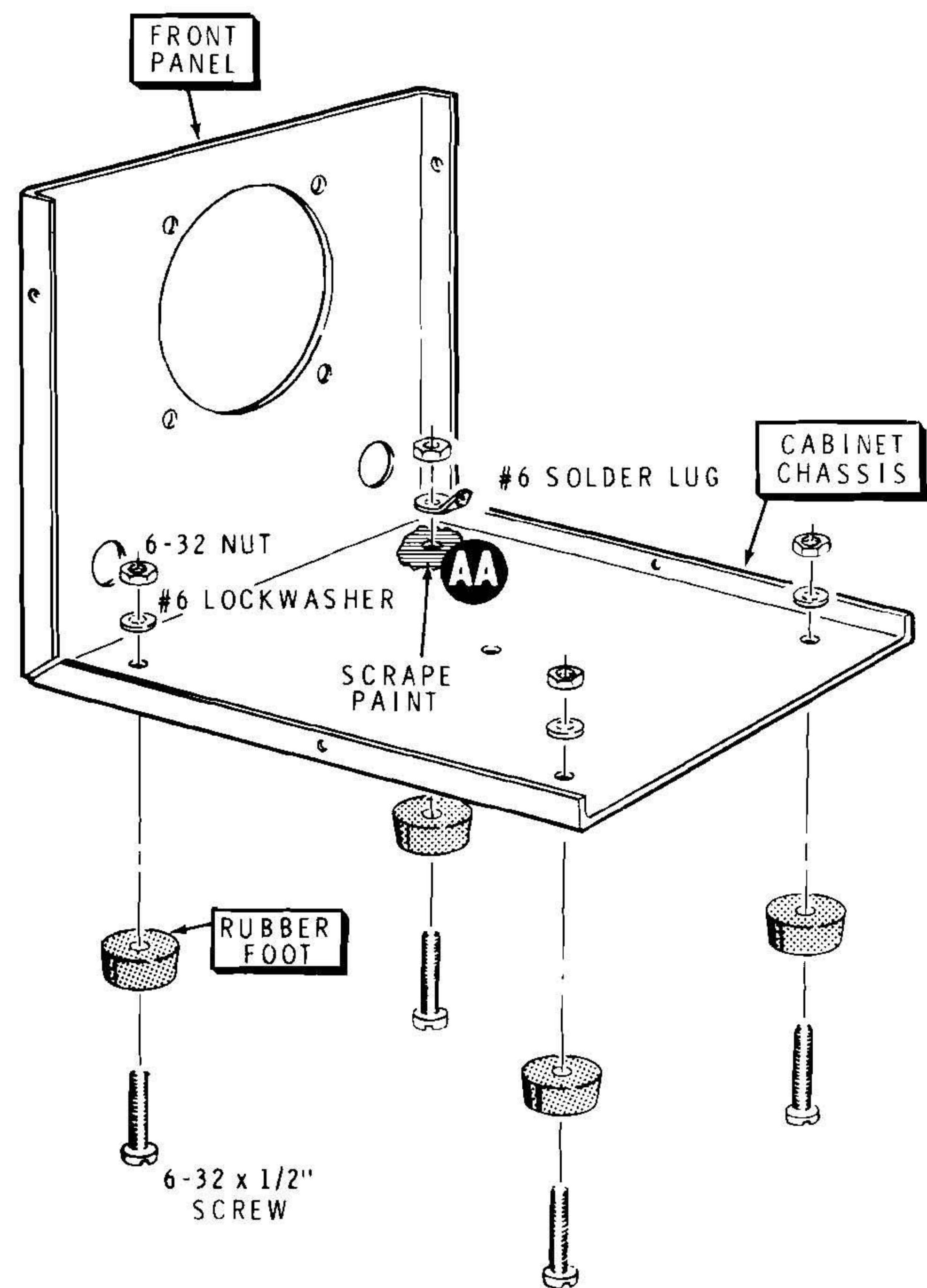
- () Refer to Detail 4A and scrape the paint from around hole AA on the cabinet chassis to provide a good ground for the solder lug.
- () Install four rubber feet on the cabinet chassis with four 6-32 x 1/2" screws, three #6 lockwashers, and four 6-32 nuts. Use a #6 solder lug at AA in place of a #6 lockwasher. Position the solder lug as shown in Pictorial 4.

Detail 4A

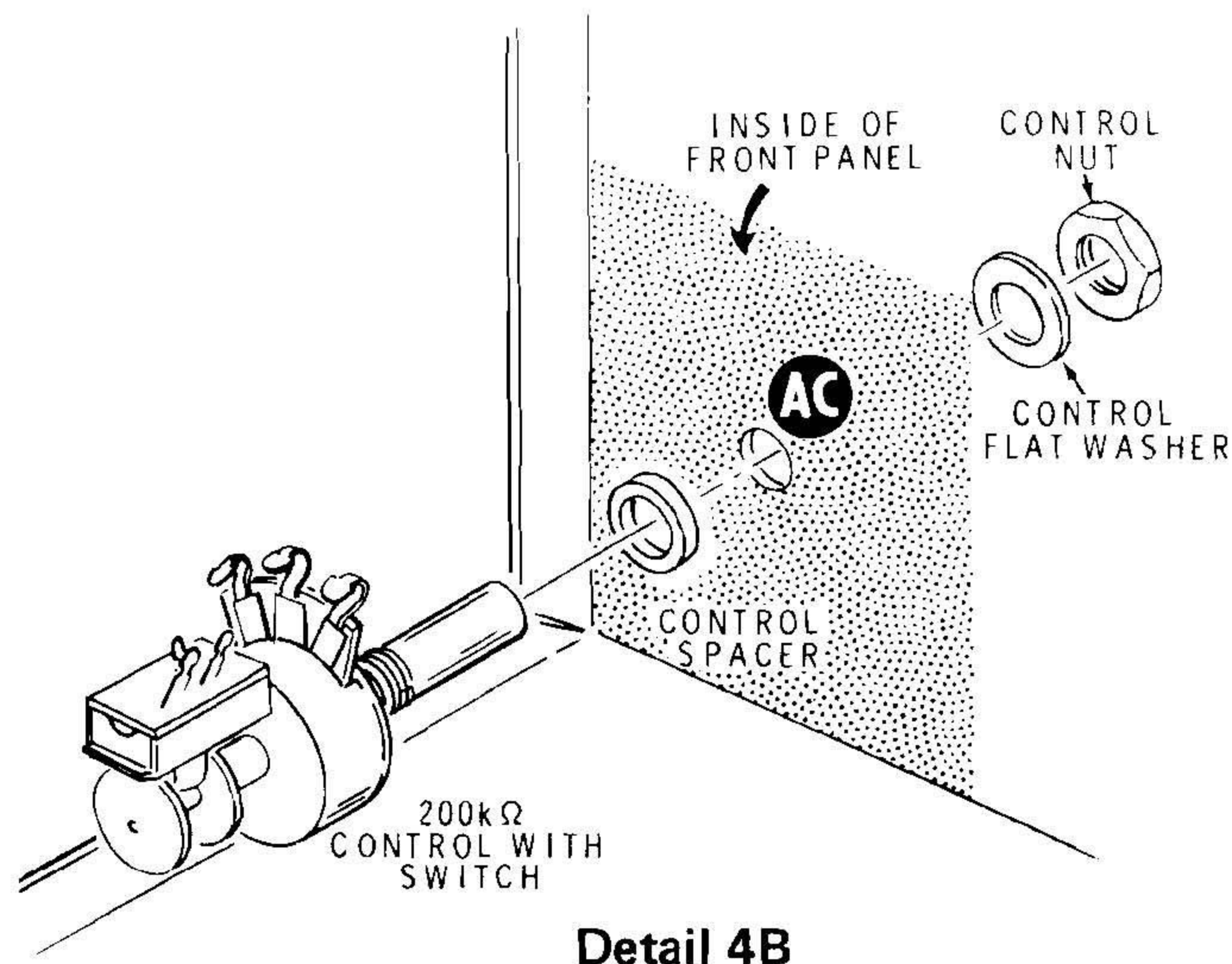

Detail 4B

- () Install the 200 kΩ control with switch at AC on the front panel with a control spacer, a control flat washer, and a control nut, as shown in Detail 4B.

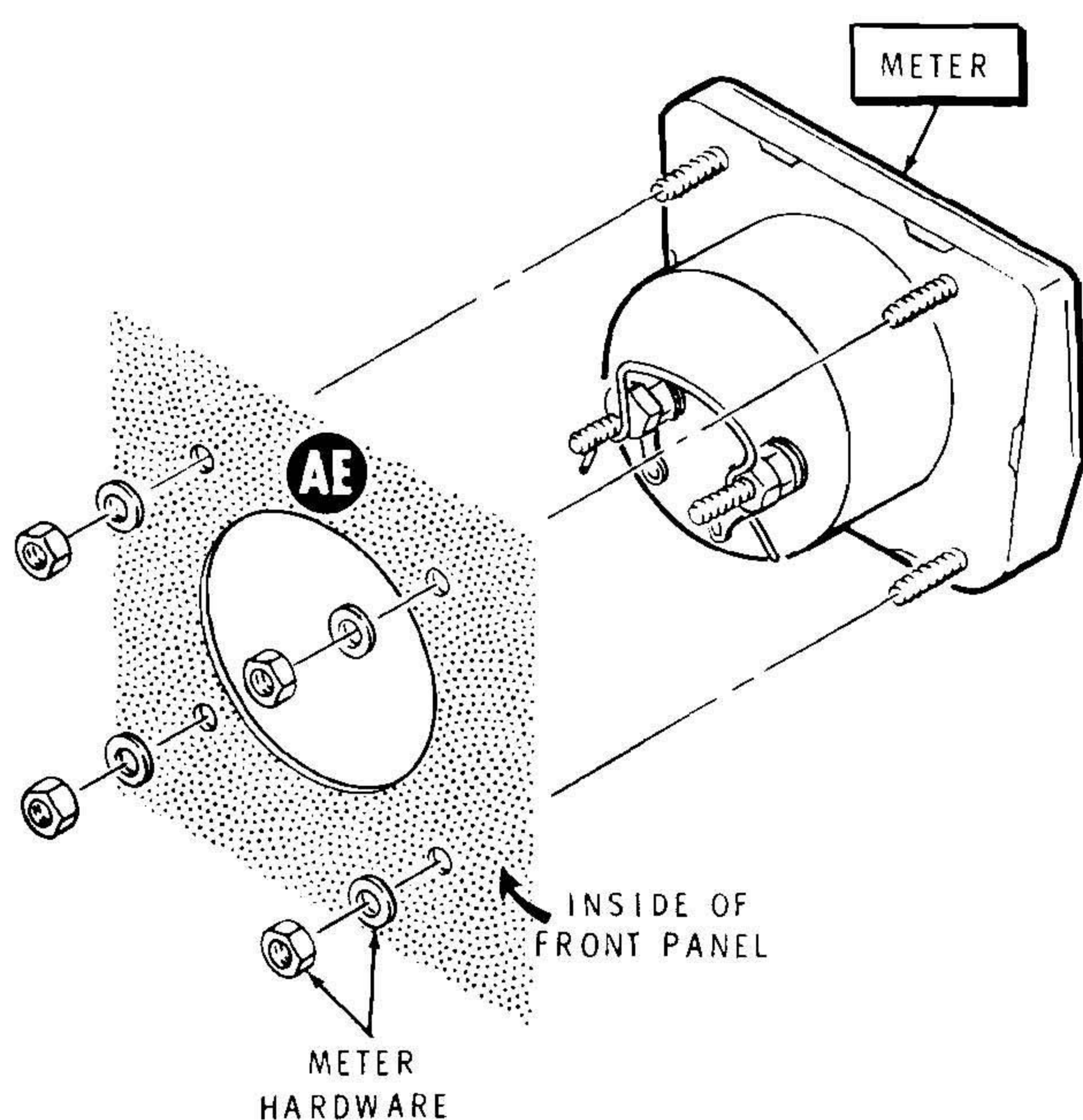

Detail 4C

- () Remove the meter from its carton and locate the meter hardware in the same carton. Mount the meter at AE; use the meter hardware as shown in Detail 4C. NOTE: Do not overtighten the meter nuts, as the meter case can be broken. Make sure the meter top is parallel with the top of the panel. The shorting wire will be removed later.

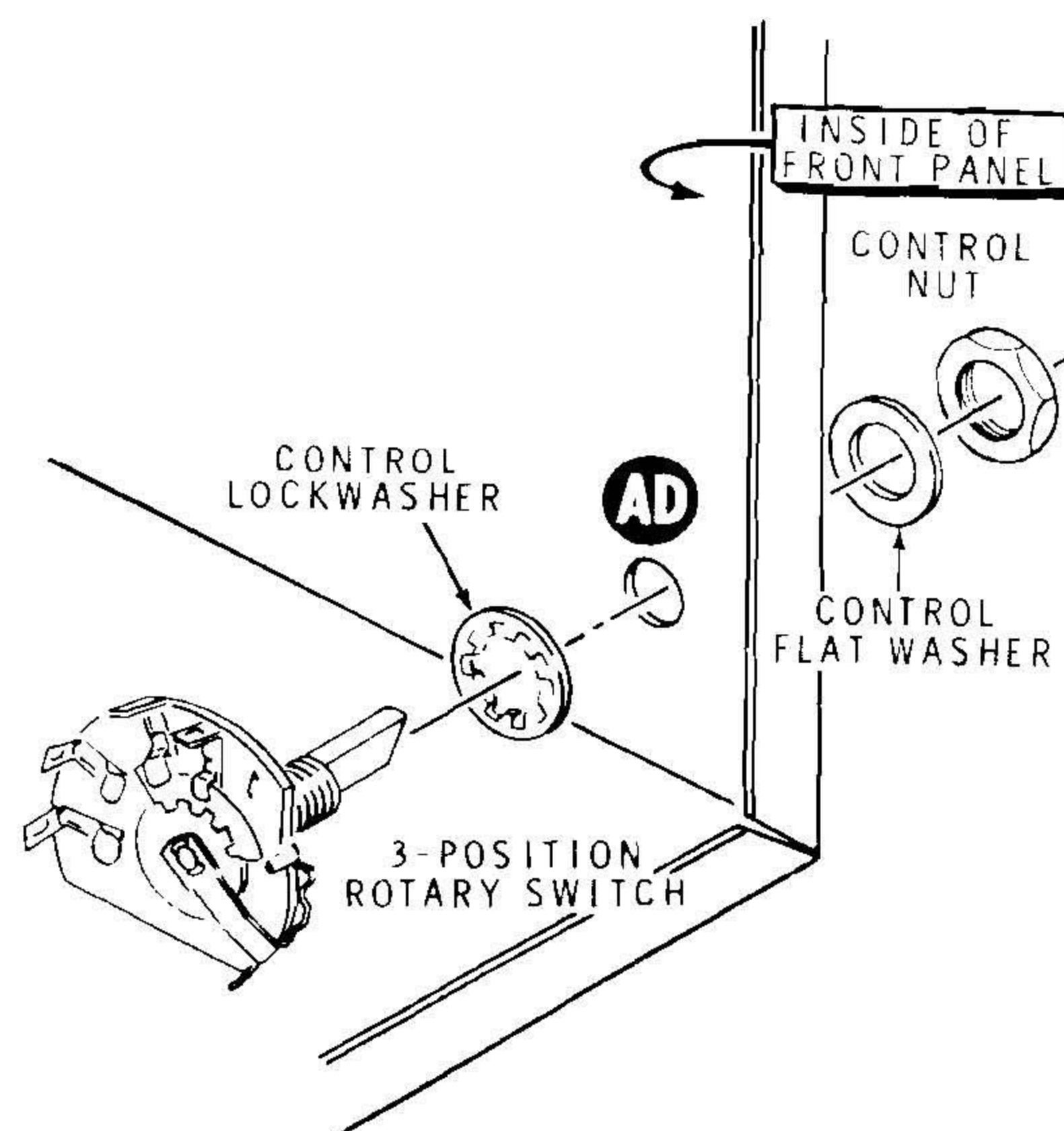

Detail 4D

- () Refer to Detail 4D and install the 3-position switch at AD with a control lockwasher, a control flat washer, and a control nut. Position the switch as shown in Pictorial 4.
- () Connect a .005 μF disc capacitor between the positive (+) lug (NS) and the negative (unmarked) lug (NS) of meter AE.

NOTE: Where a wire passes through a connection and then goes to another point, as in the next step, it will count as two wires in the solder instructions (S-2), one entering and one leaving the connection.

- () Locate the bare lead saved from the circuit board assembly and connect it from lug 5 (S-1) to lug 2 (S-1) of switch AC.
- () Cut 4" from one end of the cable. Carefully cut about 1/2" of the outer insulation from the wires in the 4" length. With a pair of long-nose pliers pull the wires out of the outer insulation. Save a 1" piece of the outer insulation to use later.
- () Prepare the 4" red, white and black wires by removing 1/4" of insulation from both ends of each wire. Then twist the wire ends tightly and apply a small amount of solder to each end to hold the small strands together.

- () Connect the red wire between the positive meter lug (S-2) and lug 1 of switch AD (S-1).
- () Connect the white wire between lug 3 of switch AC (S-1) and lug 2 of switch AD (S-1).
- () Connect the black wire between the negative meter lug (NS) and solder lug AA (S-1).

- () Connect the green wire to lug 4 of switch AD (S-1).
- () Connect the red wire to lug 4 of switch AC (S-1).
- () Connect the white wire to lug 6 of switch AC (S-1).
- () Place a cable clamp on the cable so that 1" of the outer insulation extends beyond the clamp as shown in Detail 4F. Secure the clamp to the chassis at AB with a 6-32 x 3/8" screw, a D washer, a #6 lockwasher, and a 6-32 nut.
- () Remove and discard the shorting wire from the meter terminals.

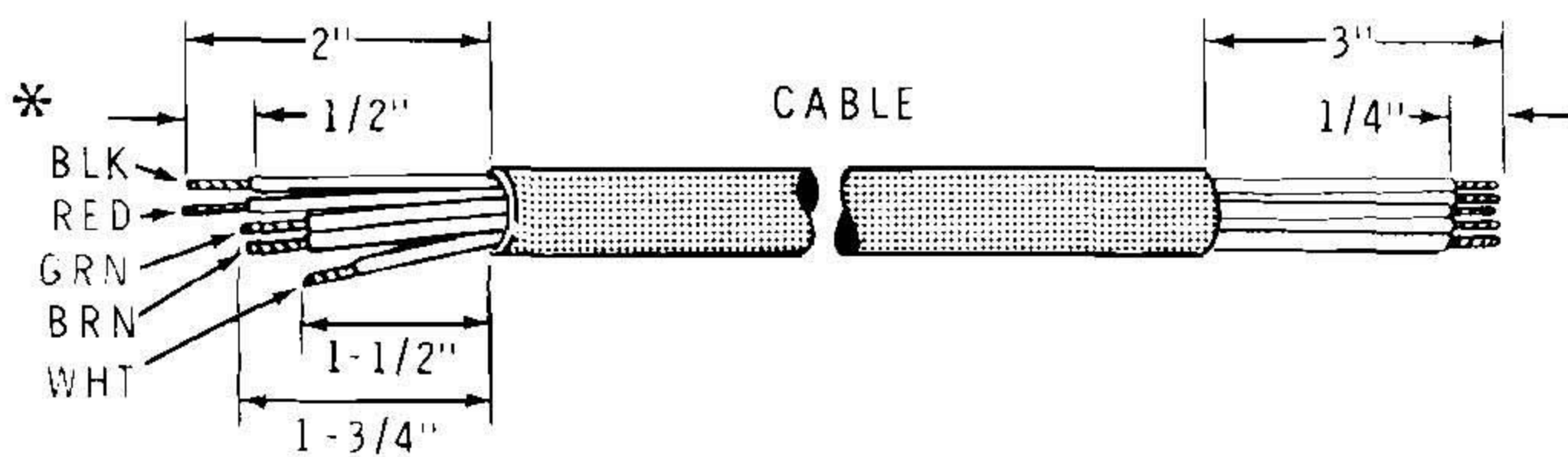
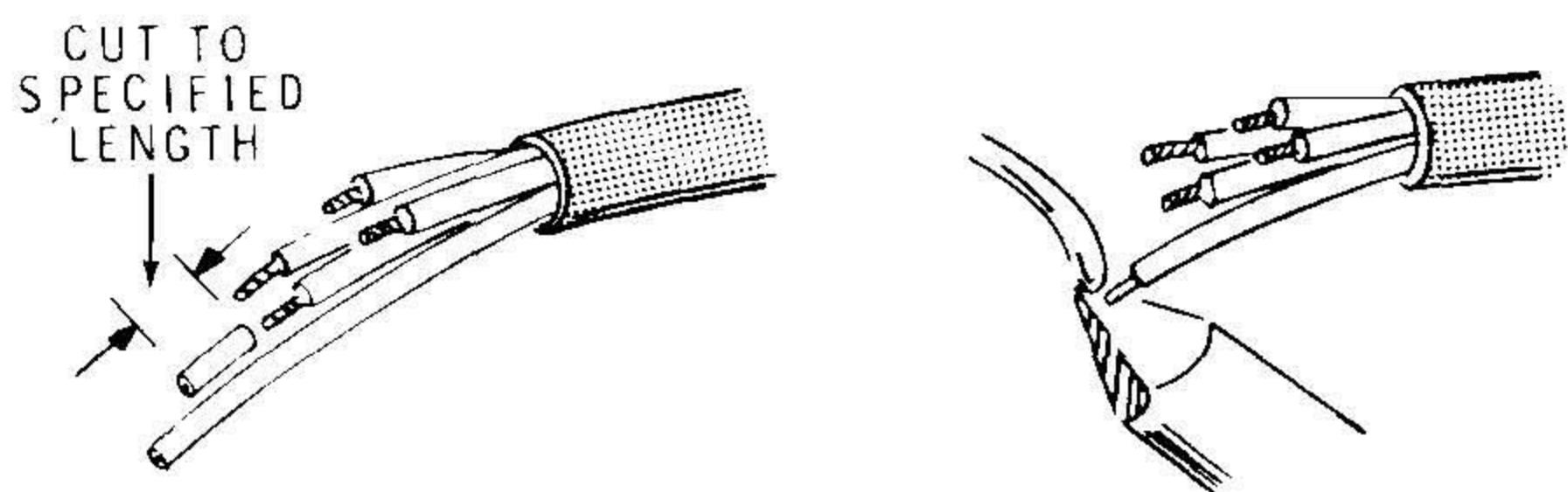
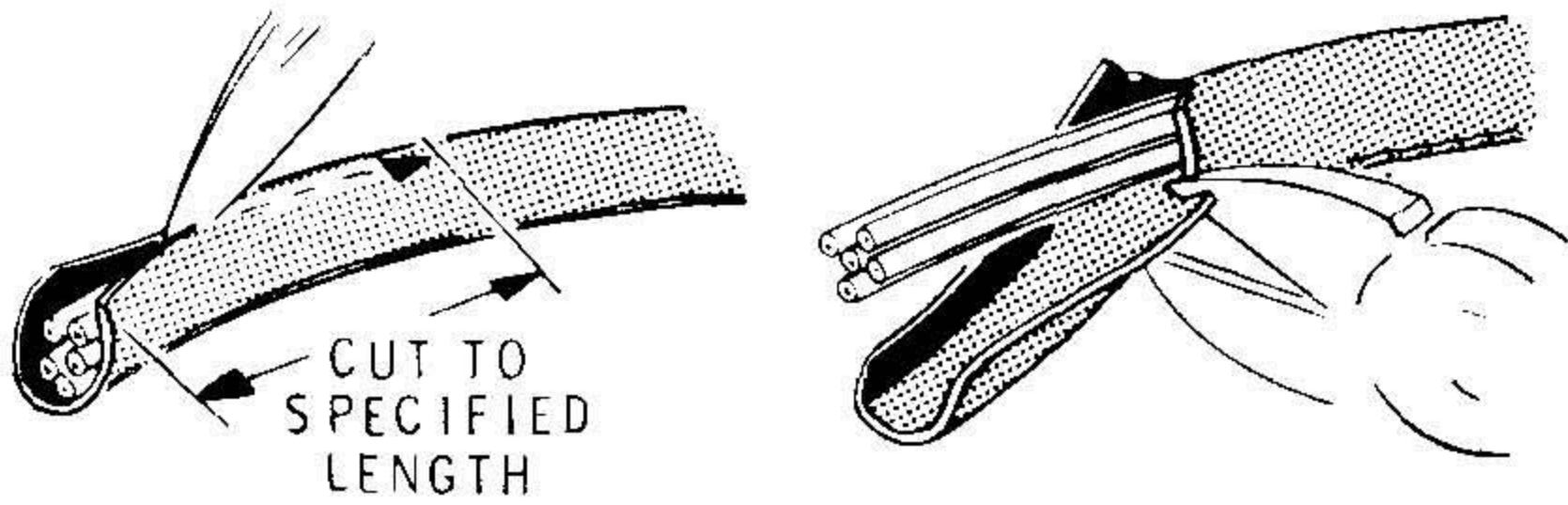

* NOTE: REMOVE 1/2" OF INSULATION FROM EACH WIRE ON THIS END.

Detail 4E

- () Refer to Detail 4E and prepare both ends of the long cable as shown. Twist the bare wire ends tightly and apply a small amount of solder to each end to hold the small strands together.

Connect the 3" prepared end of this cable to the cabinet components in the following steps.

- () Connect the black wire to the negative (unmarked) meter lug (S-3).
- () Connect the brown wire to lug 3 of switch AD (S-1).

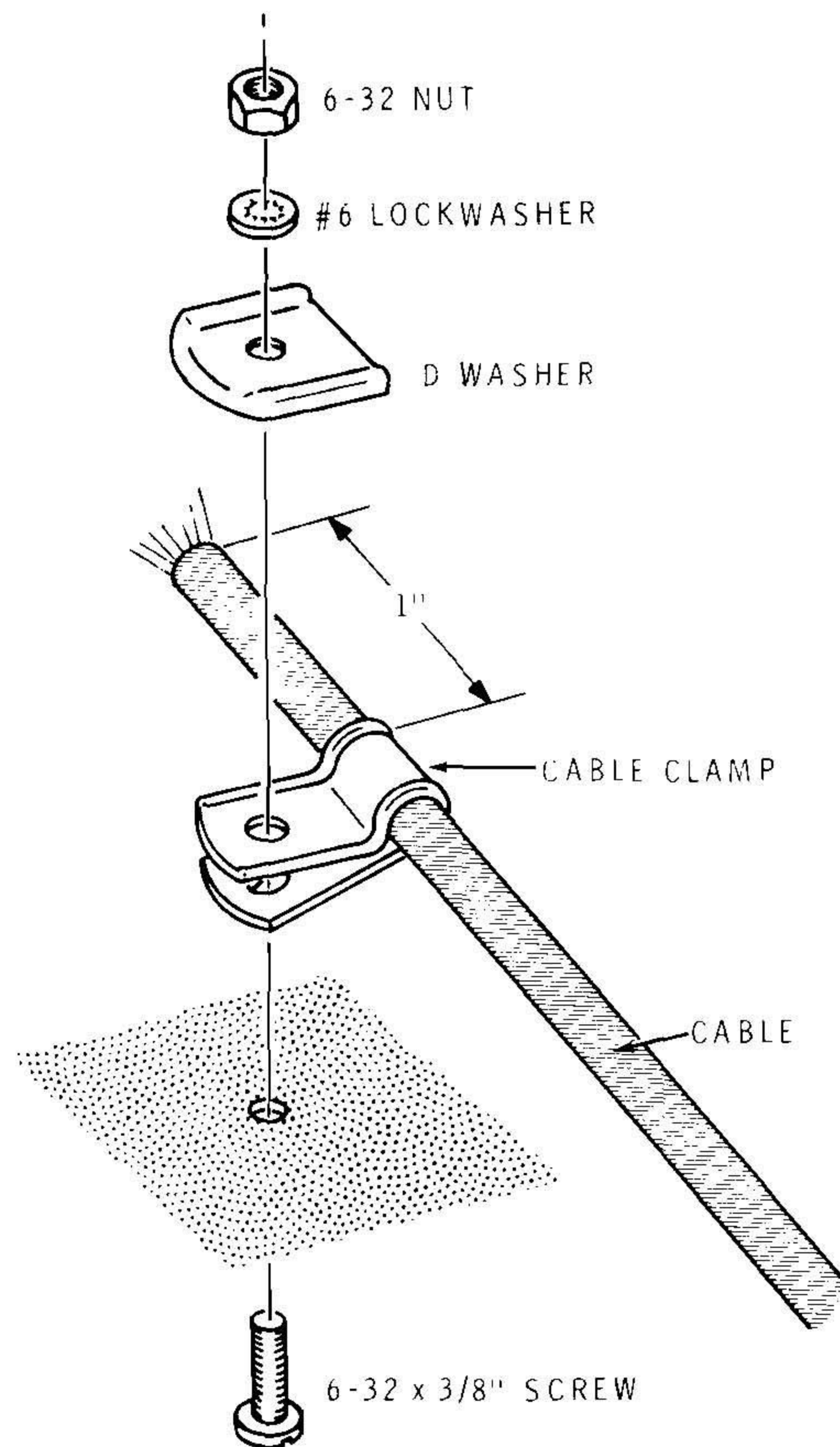

Detail 4F



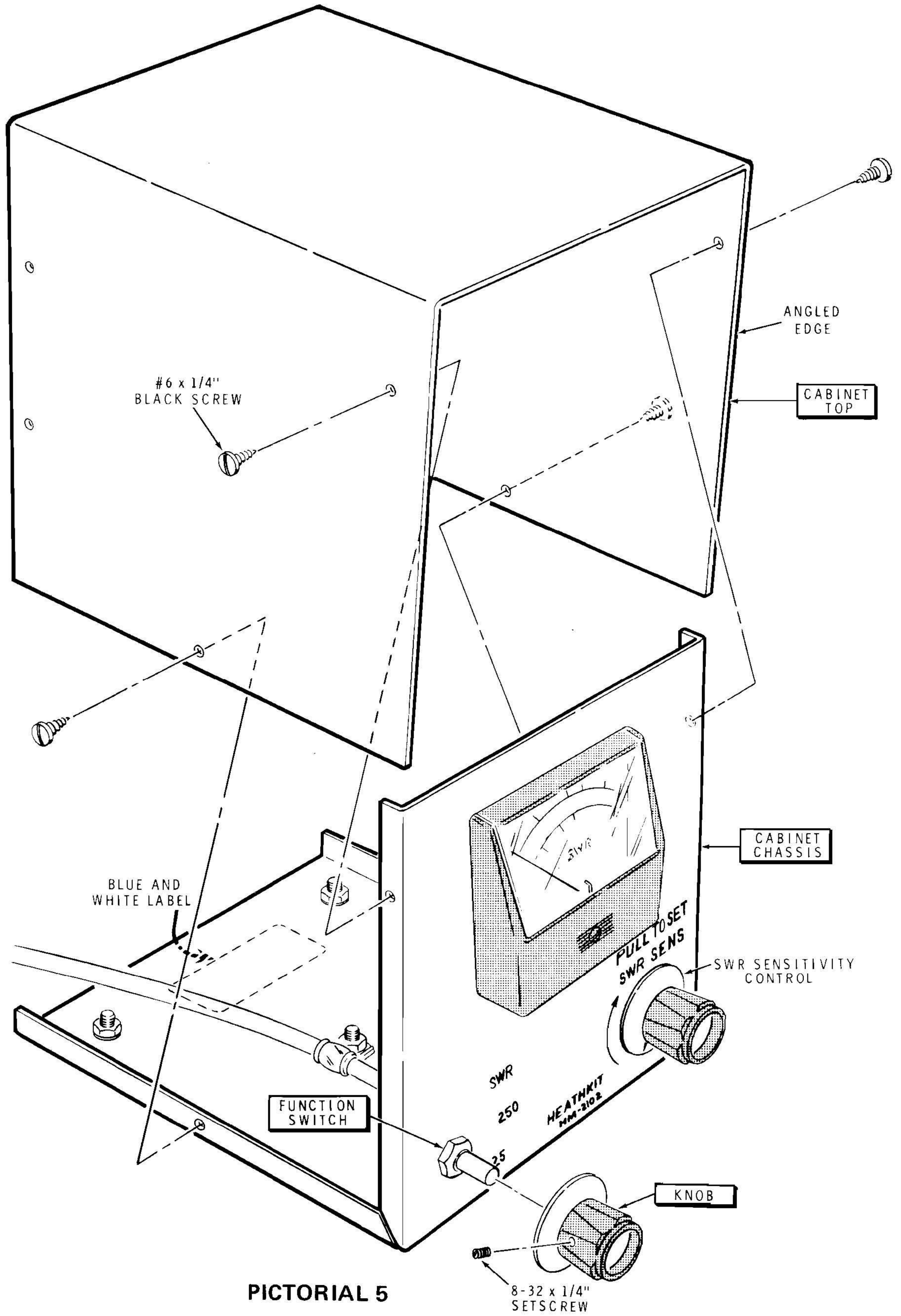

PICTORIAL 5

Refer to Pictorial 5 for the following steps.

- () Loosely secure the cabinet top to the chassis with four #6 x 1/4" black screws as shown, with the angled edge to the front.
- () Start an 8-32 x 1/4" setscrew into each of the knobs.
- () Turn the Function (SWR-250-25) switch shaft to its center position.
- () Install a knob on the Function switch shaft. Position the knob so the pointer is directly toward the "250" on the front panel. Tighten the setscrew securely.
- () Turn the SWR Sens control shaft fully counterclockwise. Place the other knob on the control shaft and position it so the pointer is at the 7 o'clock position (at the lower end of the rotation arrow); then, tighten the setscrew securely.

NOTE: The blue and white label shows the model number and production series number of your kit. Refer to these numbers in any communications with the Heath Company about this kit; this assures you that you will receive the most complete and up-to-date information in return.

- () Remove the paper backing from the blue and white label; then, press the label firmly onto the bottom of the cabinet as shown on Pictorial 5.

Refer to Pictorial 6 for the following steps.

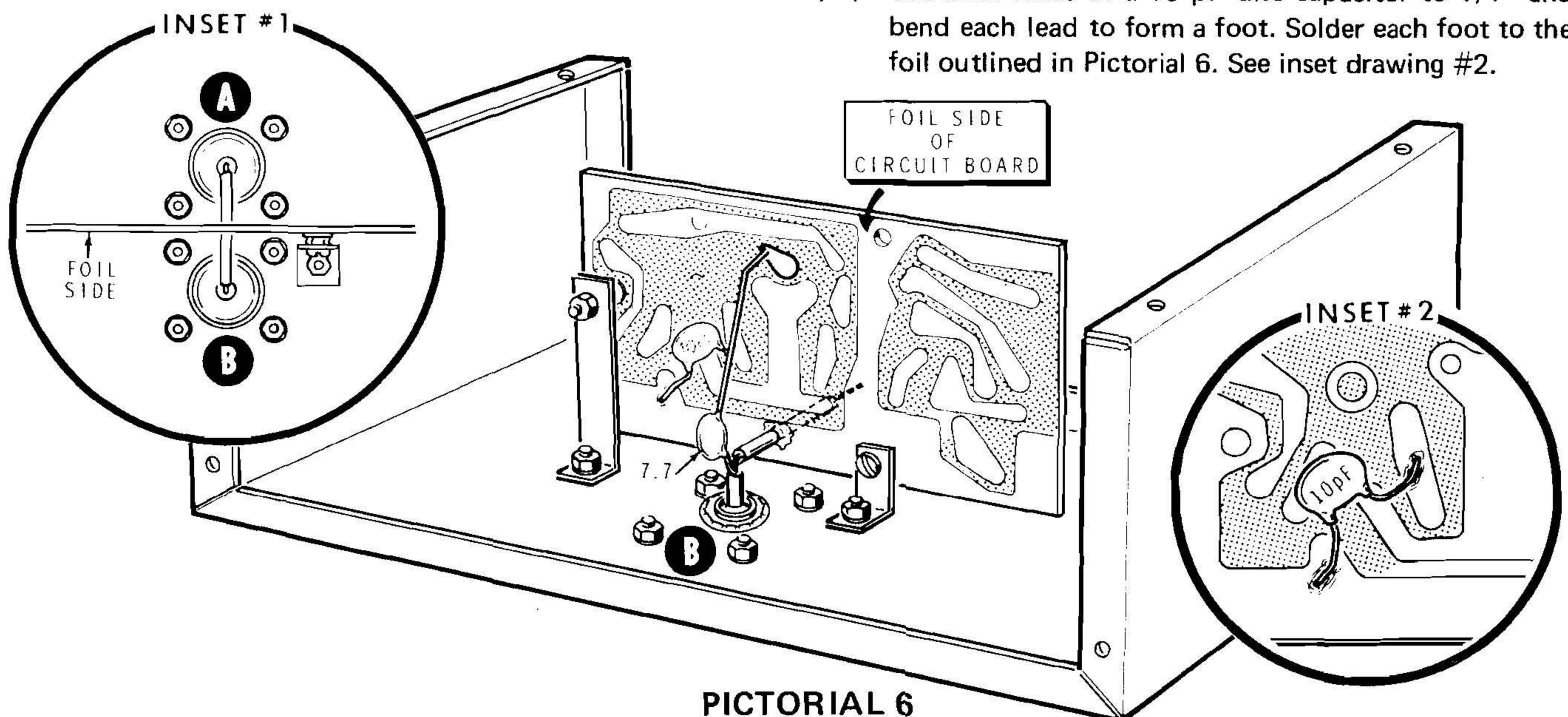

PICTORIAL 6

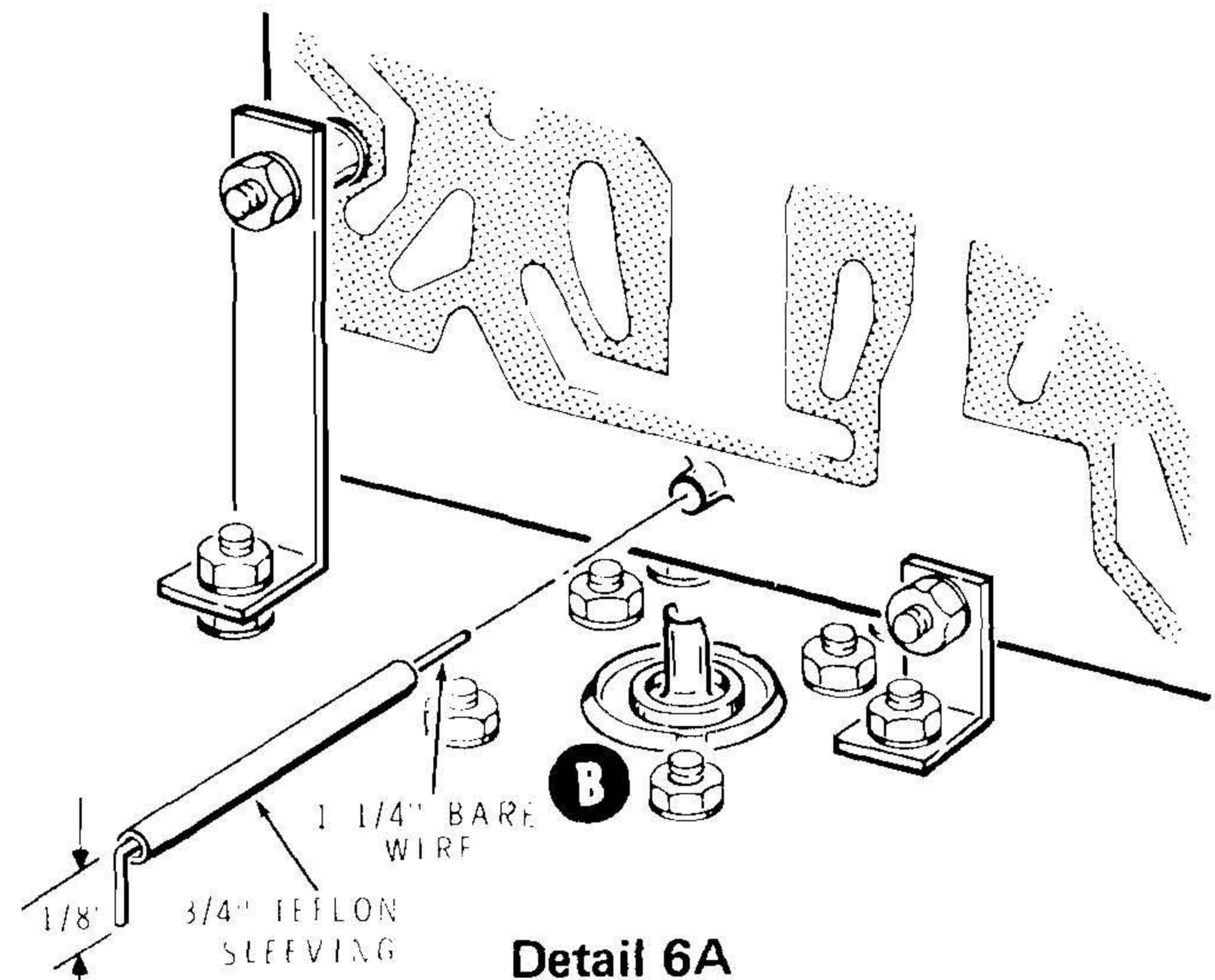

Detail 6A

- () Locate the remote chassis and place a 3/4" Teflon sleeve on a 1-1/4" bare wire. Connect this wire from the center pin of connector B (NS), through the eyelet in the circuit board, and into the center pin dip of connector A (NS). See inset drawing #1 and Detail 6A.
- () Cut one lead of a 7.7 capacitor to 1/4". Insert this lead into the center pin of connector B (S-2). Connect the other lead of this capacitor to the hole in the foil outlined in Pictorial 6 (S-1). Cut off the excess lead on the component side.
- () Cut both leads of a 10 pF disc capacitor to 1/4" and bend each lead to form a foot. Solder each foot to the foil outlined in Pictorial 6. See inset drawing #2.

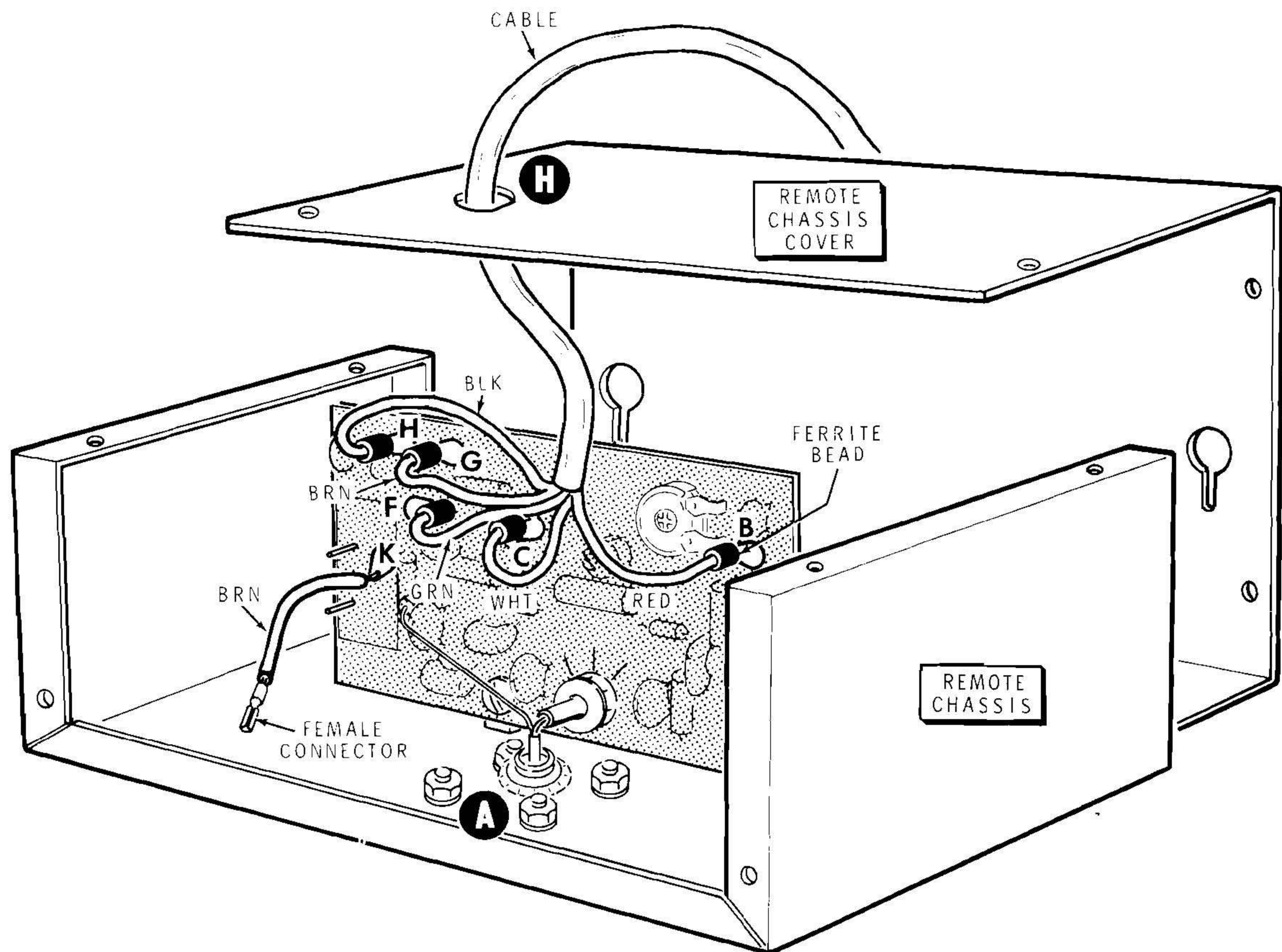

PICTORIAL 7

- () Insert the other end through hole K on the circuit board and solder it to the foil.
- () From the outside of the remote chassis cover insert the free cable end through the round hole as shown in Pictorial 7.

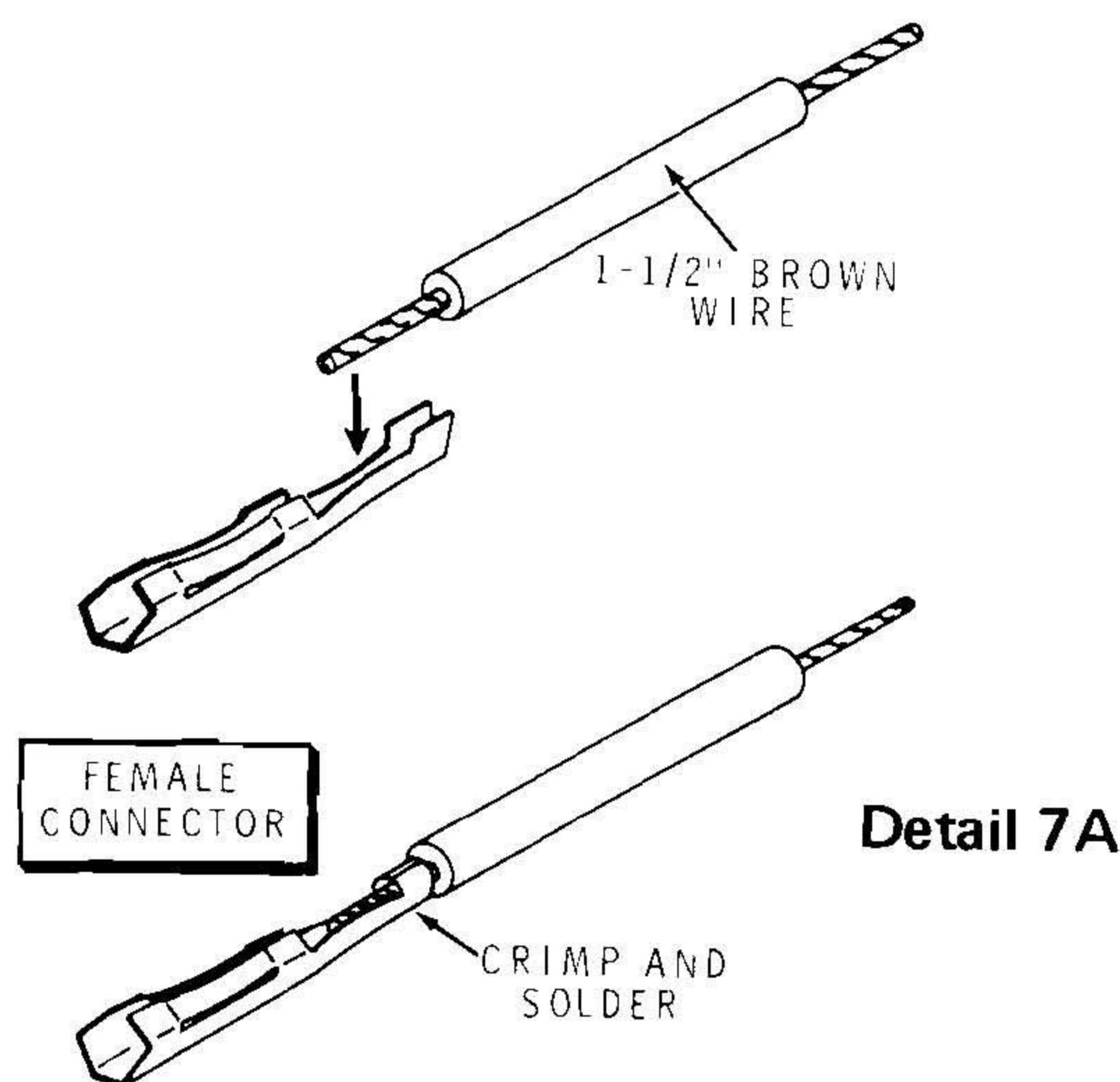

Detail 7A

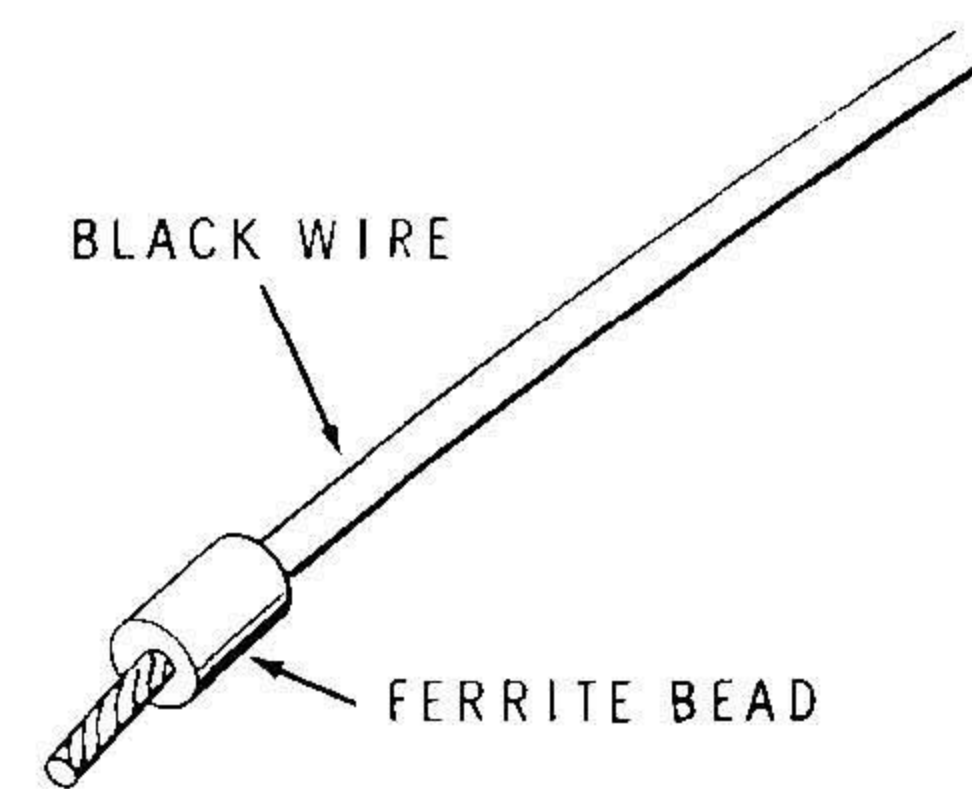

Detail 7B

Refer to Pictorial 7 for the following steps.

- () Insert the free end of the .56 pF capacitor into the center pin of connector A and solder both wires.
- () Remove 1/4" insulation from each end of a 1-1/2" length of brown wire and solder a female connector on one end as shown in Detail 7A.

- () Refer to Detail 7B and place a ferrite bead over the bare end of the black wire. Then, push the end of the black wire through hole H until the ferrite bead is down against the component side of the circuit board. Solder the wire to the foil.

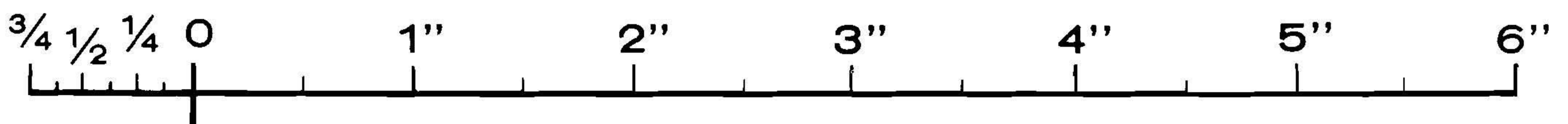

- () Install the brown wire and bead combination at G (S-1).
- () Install the green wire and bead combination at F (S-1).
- () Install the white wire and bead combination at C (S-1).
- () Install the red wire and bead combination at B (S-1).
- () Cut off the excess lead lengths on the foil side of the circuit board.
- () Carefully inspect the foil side of the circuit board and be sure that all the connections are soldered and that there are no solder bridges between foils. NOTE: Some of the circuit board holes and one capacitor will not be used.

This completes the "Step-by-Step Assembly." Proceed to the "Adjustment and Calibration" section.

ADJUSTMENT AND CALIBRATION

To perform the following steps, the Wattmeter must be connected in the transmission line between the transmitter and the load. An internal calibration circuit is provided for the calibration steps.

NOTE: If you have an accurate VHF Wattmeter, you can calibrate to it with similar results. The Wattmeter must also be connected in series with your HM-2102 VHF Wattmeter.

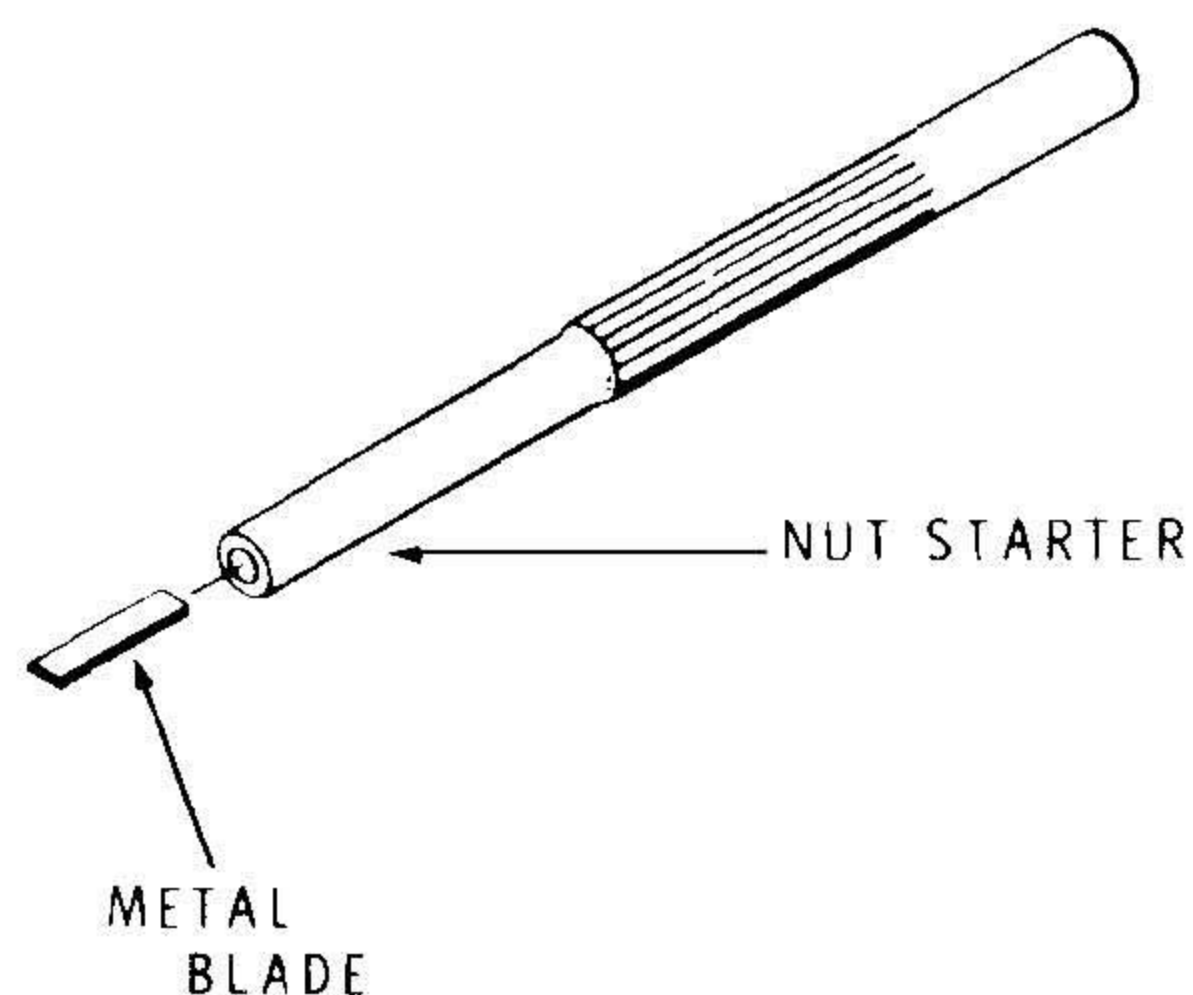

Figure 1

PREPARATION

- () Prepare an alignment tool in the following manner: Insert the 1/8" x 3/4" alignment tool blade into the small end of the nut starter as shown in Figure 1. Leave 1/4" of the blade exposed.
- () Check to see that the meter needle is directly over the zero on the scale. If it is not, adjust the screw on the meter case slightly to position the needle over the zero.
- () Connect a 50 Ω noninductive load, such as the Heathkit Antenna to the remote chassis OUTPUT jack.
- () Connect the transmitter output to the INPUT jack.

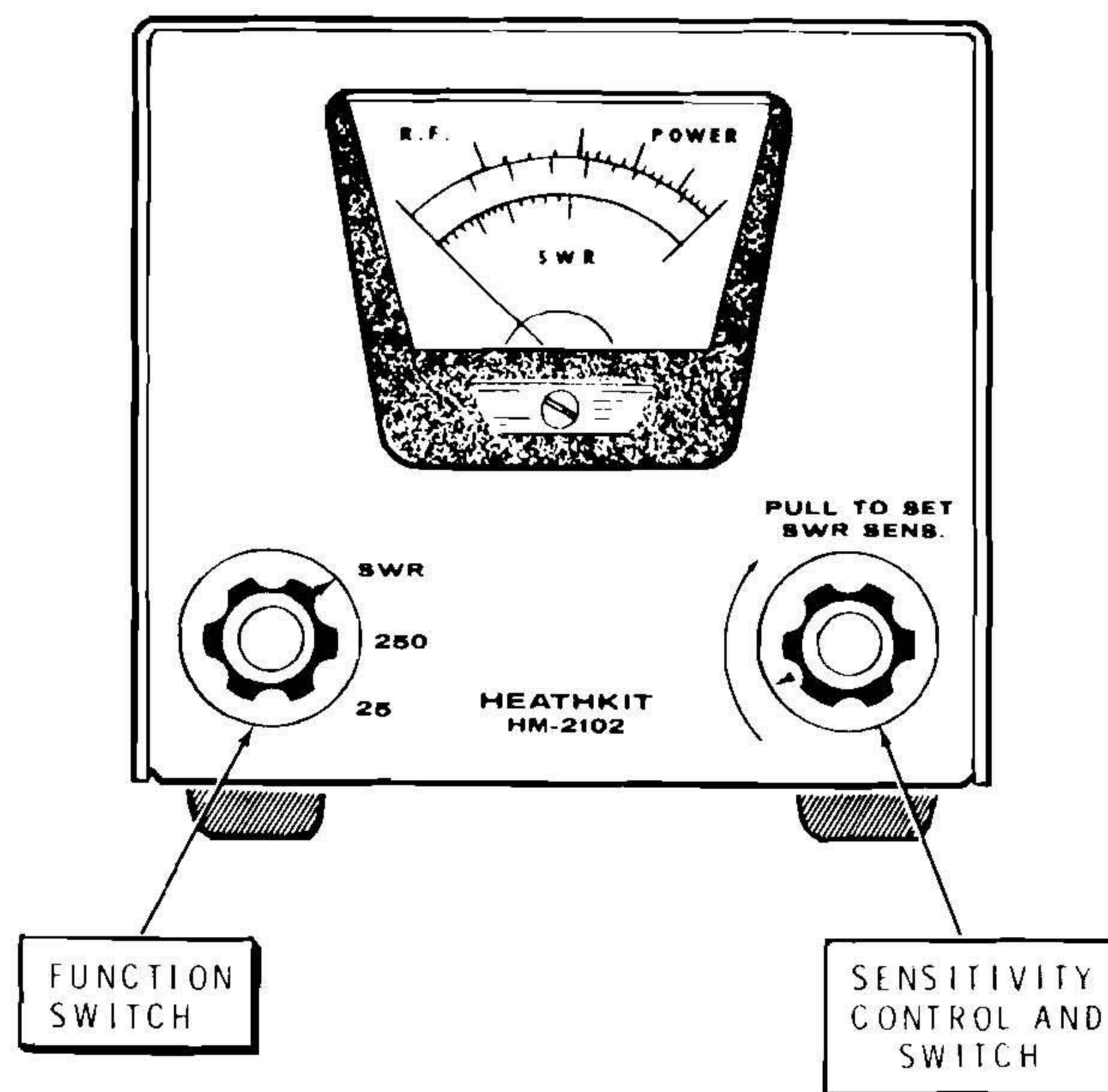

Figure 2

- () Set the FUNCTION switch to 25 (see Figure 2).
- () Push the SWR SENS control knob in and turn the control fully counterclockwise.

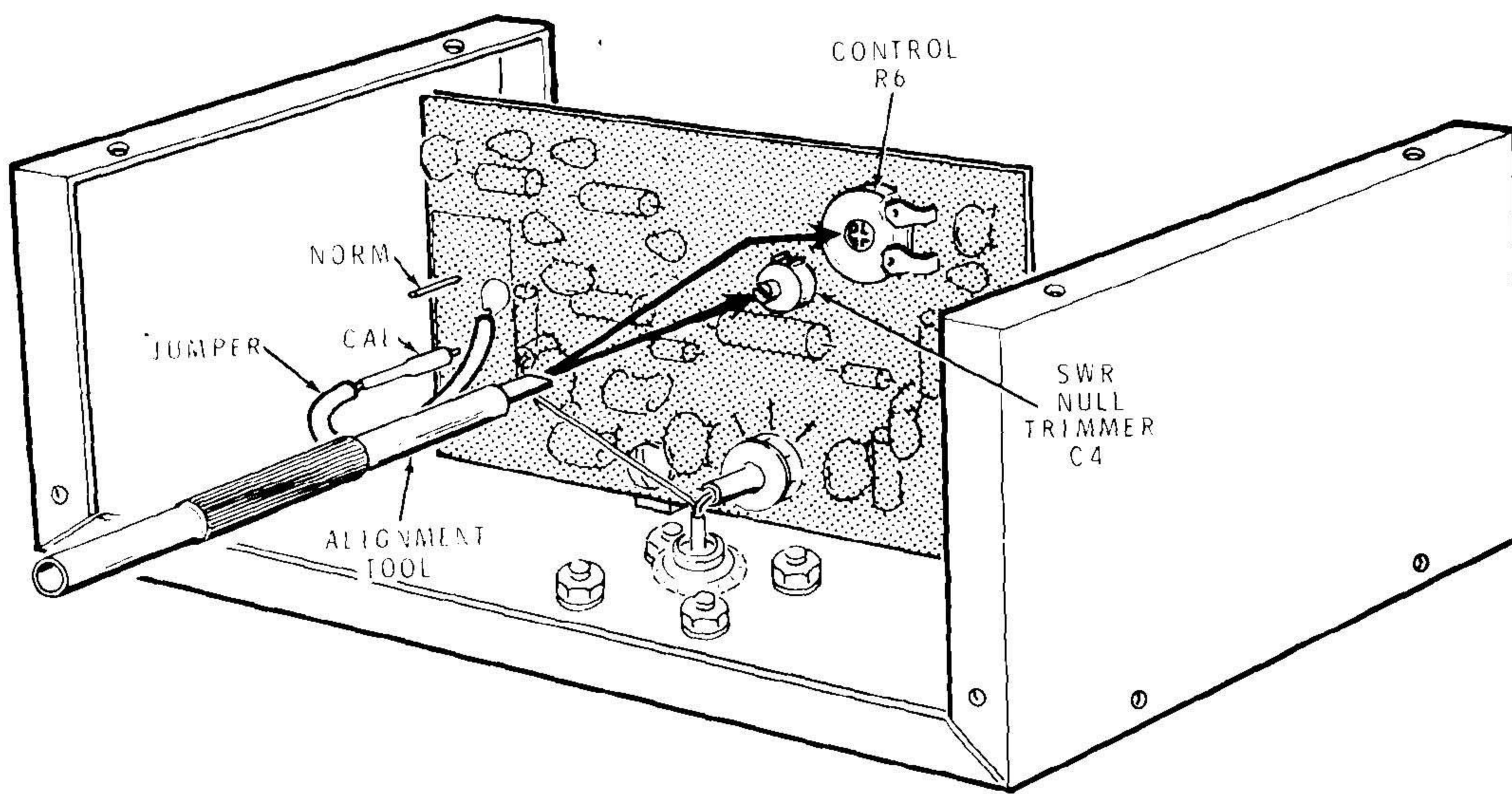

Figure 3

- () Connect the CALIBRATION JUMPER on the remote chassis circuit board to the CAL pin. (See Figure 3 fold-out from this page.)
- () Turn on the transmitter and set it to the CW mode in the 6 or 2-meter band. Then tune the transmitter and watch the RF Power Meter needle move up-scale. If the meter needle does not move up-scale, refer to the "In Case of Difficulty" section of this Manual.

SWR BALANCE ADJUSTMENT

- () Set the FUNCTION switch to SWR.
- () Apply transmitter power and adjust the SWR SENS control for a midscale reading.
- () Refer to Figure 3 and adjust SWR NULL trimmer C4 on the circuit board for the best null or greatest dip of the meter needle. This reading should be at or near zero. NOTE: Use only the alignment tool (nut starter) for this adjustment.
- () Readjust the SWR SENS control for a maximum reading.
- () Repeat the two preceding steps. Make these final adjustments carefully and precisely. The accuracy of the instrument depends on a well balanced bridge circuit.
- () Pull the SWR SENS knob to its out position. Then set SWR SENS control for a full-scale reading.
- () Push the switch in and note the meter reading. If the meter reads higher than 1.5, refer to the "In Case of Difficulty" section of the Manual.

POWER METER CALIBRATION

The internal calibration circuit may be used for calibration with 5-watt to 15-watt transmitters on the 2-meter (6-meter, if C2 is 14 pF) band.

An external wattmeter may be used with transmitters at frequencies of 50 to 160 MHz and power up to 200 watts. (The internal calibration circuit is not used in this case.)

Either procedure will give accurate results over the full range specified for your Wattmeter. However, the accuracy of the external wattmeter will determine how accurate your Wattmeter will be.

Use only one of the two following procedures.

Internal Calibration

1. () Turn the FUNCTION switch to 25.
2. () Connect the CALIBRATE Jumper on the circuit board to the CAL pin.
3. () Tune the transmitter on the 2- (or 6-) meter band.
4. () Note the meter reading.
5. () Connect the CALIBRATE jumper to the NORM pin and adjust POWER CALIBRATE control R6 with the alignment tool so the meter reads the same as noted in step 4.
6. () Repeat steps 2, 4, and 5 until the meter readings for both CAL and NORM connections are the same.
7. () Connect the CALIBRATE jumper to the NORM pin.

This completes the "Internal Calibration" of your VHF Wattmeter.

External Calibration

- () Connect the external wattmeter.
- () Turn the FUNCTION switch to 25.
- () Tune the transmitter on the 2-meter (or 6-meter) band.
- () Note the external wattmeter reading.
- () Connect the calibrate jumper to the NORM pin and adjust POWER CALIBRATE control R6 so both meters read the same.

This completes the "External Calibration" of your VHF Wattmeter.

FINAL ASSEMBLY

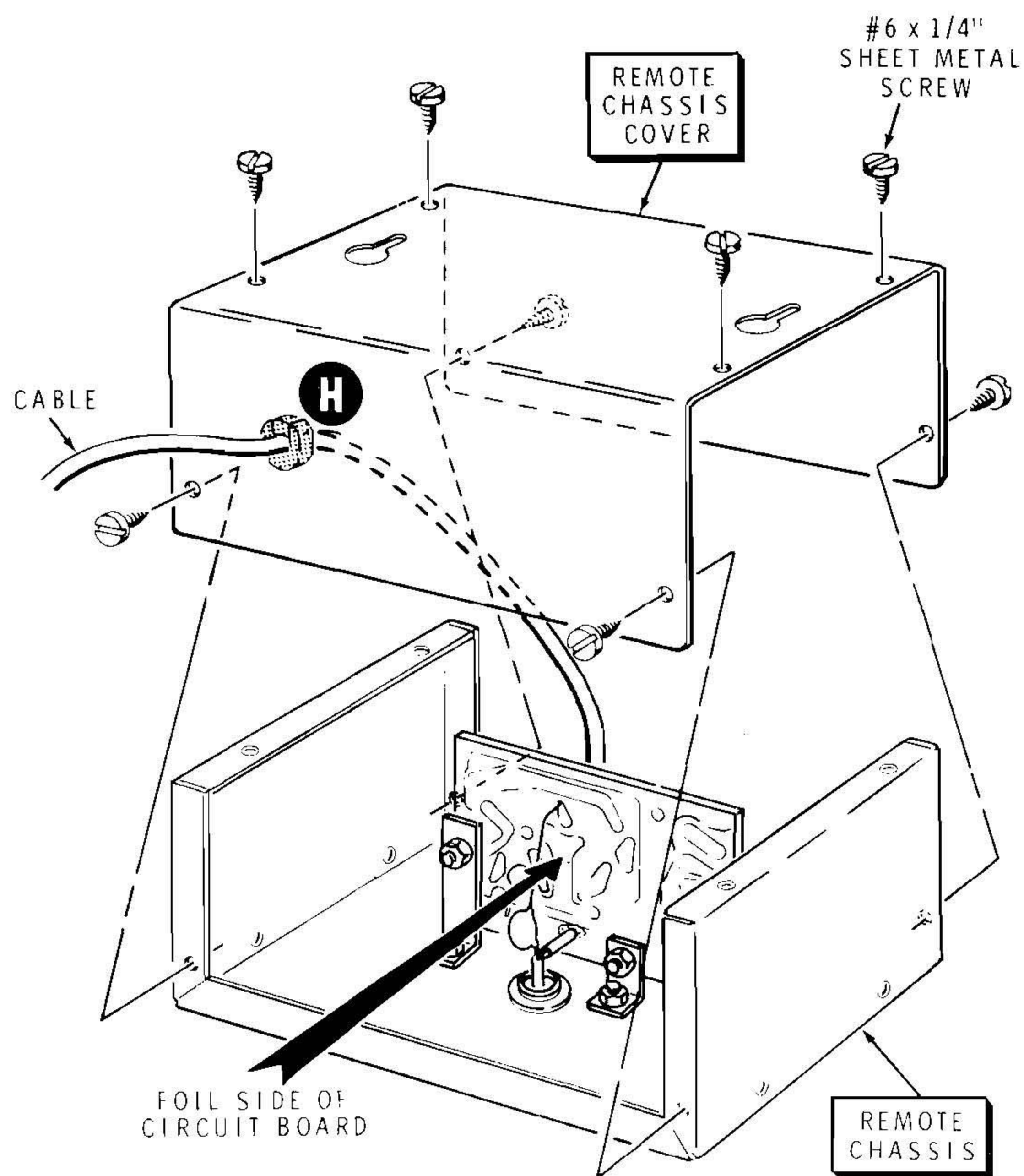

PICTORIAL 8

Refer to Pictorial 8 for the following steps.

- () Disconnect the transmission line and place the remote chassis face down on your work surface. Place the cover on the remote chassis with the cable routed against the chassis to emerge from the side of the cover facing you as shown.
- () Secure the cover to the chassis with eight #6 x 1/4" sheet metal screws. Do not use the black screws.

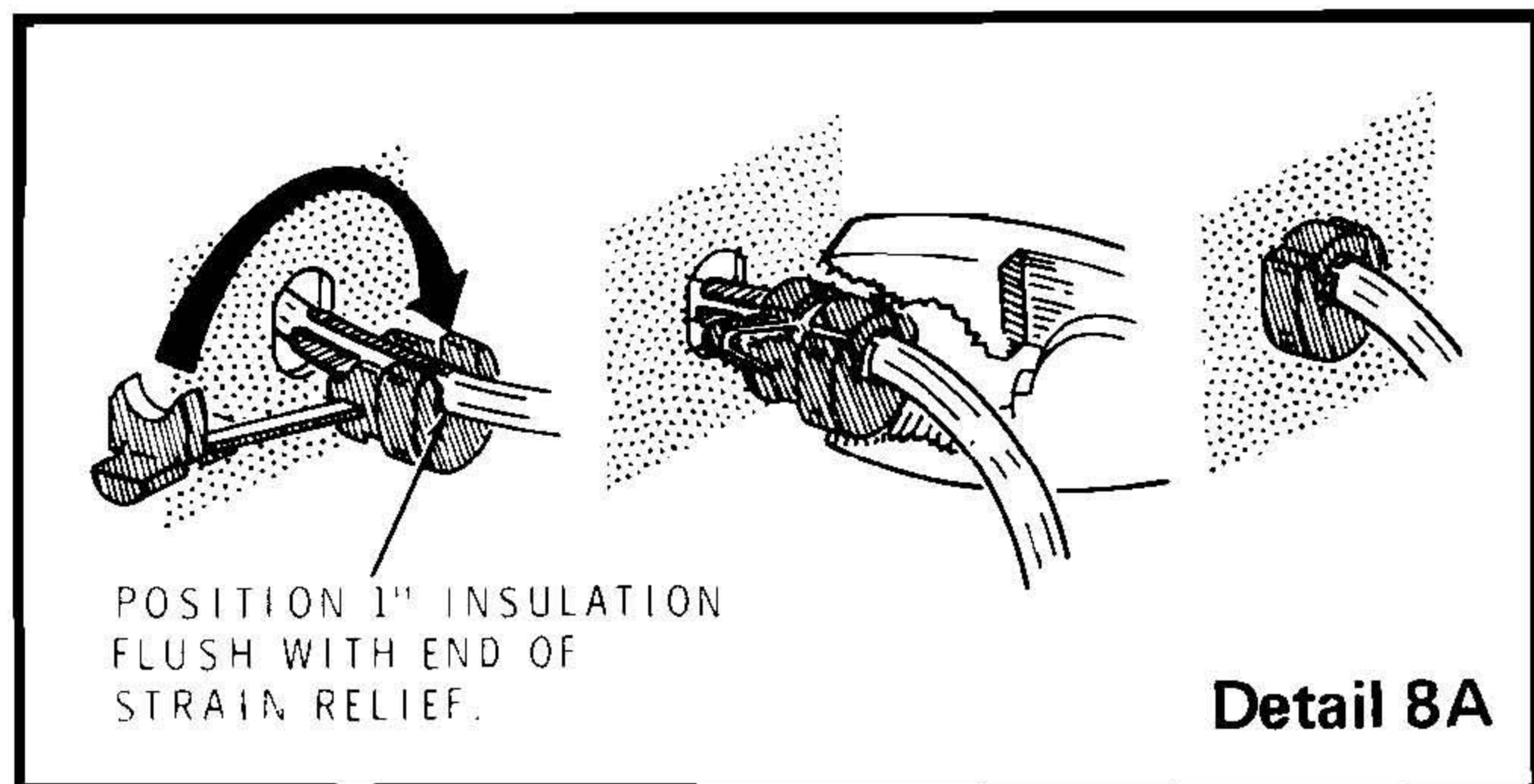

- () Refer to Detail 8A and install the cable strain relief on the cable in hole H as follows: Locate the 1" length of outer insulation saved from the previous step and slit it. Gently pull the cable from the remote chassis and

place the length of insulation and the strain relief on the cable 1" from the hole. Then, with pliers, insert the strain relief in the hole.

Refer to Pictorial 9 for the following steps.

NOTE: In the following steps, you will install the remote chassis in the cabinet. If you wish to place the remote chassis in some location away from the cabinet, so the remote unit will be near the transmission lines, do not complete the following steps. In this case, place the four black screws in a small envelope and tape them to the bottom of the cabinet. Tighten the four cabinet screws and proceed to the "Operation" section of the manual.

- () Position the remote chassis inside the top rear opening of the cabinet. Then secure the remote chassis to the cabinet with four #6 x 1/4" black screws.
- () Tighten the other four black cabinet screws.
- () Coil the cable neatly and slide it into the opening beneath the remote unit.

This completes the "Final Assembly" of your VHF Wattmeter. Proceed to the "Operation" section of the manual.

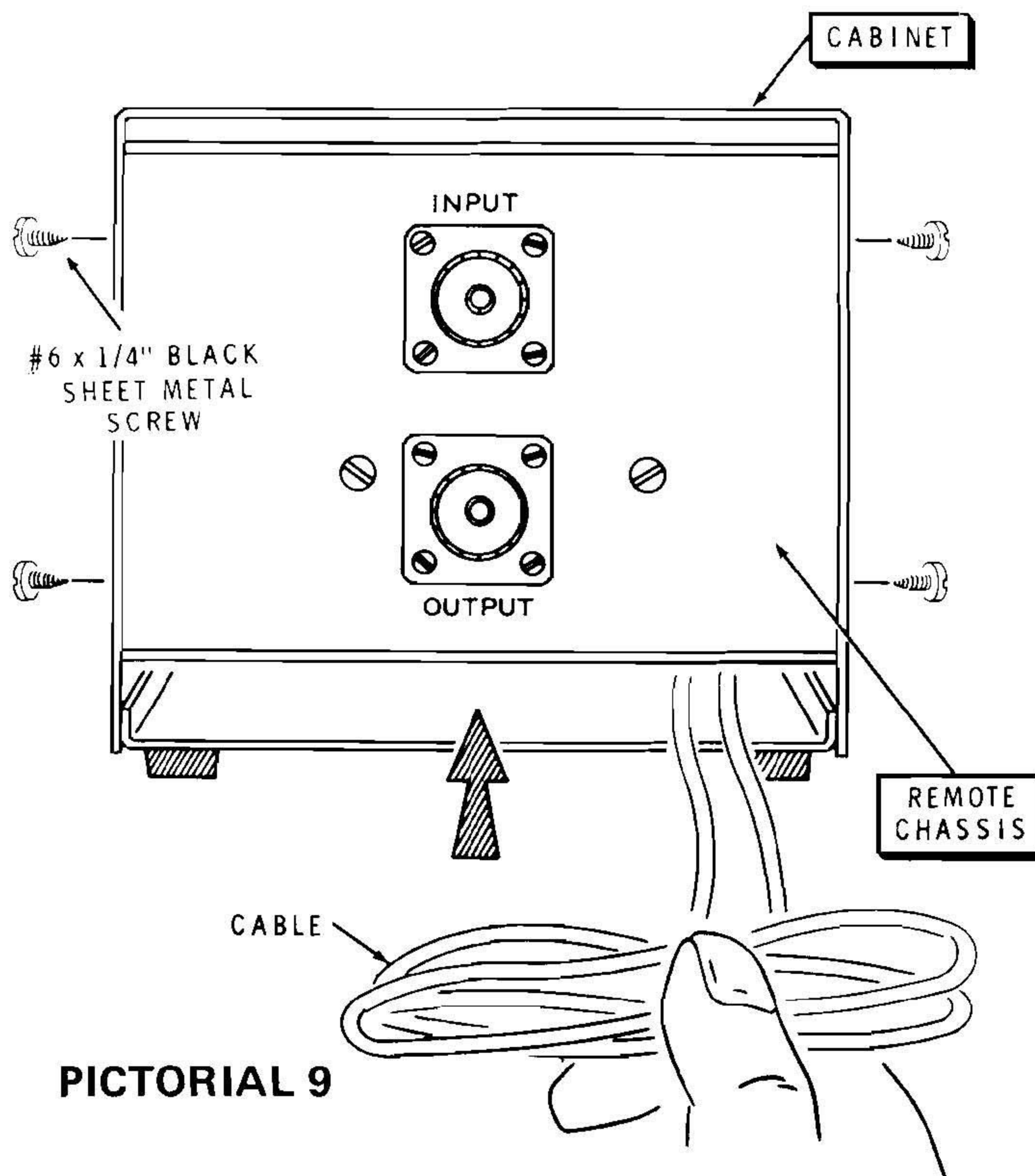

PICTORIAL 9

OPERATION

The Wattmeter (SWR Bridge) may be left in the transmission line at all times for continuous monitoring purposes.

SWR METER

NOTE: The Wattmeter SWR bridge can only be used with 50-ohm nominal transmission lines. It will not work on transmission lines that are used as tuned feeders, since tuned feeders normally have a high SWR.

1. Turn the FUNCTION switch to SWR.
2. Pull the SWR SENS switch out and turn it fully counterclockwise.
3. Apply power to the transmitter and tune it for maximum RF output reading. Disregard the Power Meter readings at this time.
4. Turn the SWR SENS control clockwise for a midscale meter reading. A minor "touch-up" tuning of the transmitter may show an increase on the Meter. This indicates a closer match between the transmitter and the transmission line.
5. Turn the SWR SENS control clockwise to give a full-scale meter reading.
6. Push the SWR SENS control knob in and read the SWR directly on the lower meter scale.

Normal Operating Characteristics

The peaks on controlled carrier modulation will "kick" the meter needle upward. SSB and DSB signals will give a bouncing indication when transmitting; so no SWR measurement can be made with these signals. Therefore, use a single-tone or CW carrier with sideband transmitters when taking readings. When operating SSB, any indication with no modulation indicates spurious or parasitic emission, or poor carrier suppression.

Physical Placement and Losses

The detector unit may be removed from the cabinet and placed at a location more convenient for connection to your

transmission line. The interconnecting cord that is furnished may be replaced by a longer one, if this is desired. You may even position the detector unit at the antenna, although there is always the possibility of RF pickup on the extended interconnecting cable from the transmission line. If this should occur, the use of properly grounded, shielded interconnecting cable may be required. NOTE: The remote cabinet is not weatherproofed. Any outdoor application should be temporary.

The SWR meter readings may vary if the Meter is placed at different locations in the transmission line, or if the length of the transmission line is changed. For this reason, assume that the highest SWR reading is most correct.

Misleading readings may be obtained with long transmission lines since the losses in the cable tend to "smooth out" the standing waves, giving a much better indication at the transmitter than actually exists at the antenna. Therefore, if you are using a transmission line long enough to have appreciable losses, locate the Wattmeter near the antenna, especially when adjusting beams or tuning traps. You can better understand the extent of this effect when you realize that a line with a 3 dB loss will show an SWR of 3:1 when it is terminated in a dead short. A line with a loss of over 10 dB will show an SWR of practically 1:1, on this or any other SWR meter, regardless of what load or termination is connected at the far end.

The power losses in these cases are occurring in the cable, but the SWR meter reading will not indicate that anything is wrong. When in doubt, make measurements at the antenna and at the transmitter, so future changes in the readings will be meaningful. The values of cable losses at various frequencies can be obtained from Figure 4. These losses become worse as time and moisture affect the cable.

With a high SWR, the transmission line losses may become so great that the radiated power is appreciably reduced; with high-power transmitters, the cable ratings may be exceeded. Figure 5 shows the effect of increasing cable losses caused by various values of SWR. When these losses occur, the RF power is turned into heat in the cable instead of being radiated from the antenna.

To obtain total losses in a given length of coaxial cable, determine the dB loss per foot of the cable from Figure 4. This is done by finding your operating frequency on the bottom line of the chart, and moving up to find the type of cable used. By looking at this same level on the left-hand side of the chart, you can read the dB loss per 100 feet of the cable at that frequency.

Now determine the additional loss caused by the SWR from Figure 5 as follows: Use the amount of loss determined from Figure 4 and find this value on the bottom line of Figure 5. Now move up the graph until you come to the SWR of your antenna system. Move over to the left-hand side of the graph and determine the amount of loss caused by the SWR. To obtain the total loss of your system, add the value from Figure 4 to the value from Figure 5. Multiply the total loss by the cable length in feet. Then divide by 100.

Loading

The load presented to the transmitter output circuit may create conditions that make it touchy or impossible to load the transmitter. With a low SWR, the load that the transmitter sees is practically pure resistive. However, at a high SWR, the apparent load may change from a very low to

a very high resistance, accompanied by either capacitive or inductive reactance. These resistance and reactance values change when the transmission line length or frequency is changed.

Remember when you are using 50 Ω nominal unbalanced feed lines that the SWR cannot be changed by changing the transmission line length. However, the loading to the transmitter may be changed considerably; thus making it appear that "pruning" the cable length offers improvement, when it actually does not affect the SWR.

The SWR can only be changed by changing the load or termination at the cable. If the transmission line length is changed, for example, with 50 Ω cable and an SWR of 3:1, the apparent load to the transmitter may vary from 16-2/3 Ω to 150 Ω resistive in series with reactance varying from 66-2/3 Ω capacitive, to zero, to 66-2/3 Ω inductive. If the transmitter output tuning adjustments will not accommodate this impedance range, the transmitter will be difficult to load until the load is properly matched to the line. When the load is matched, the SWR will be low, approaching 1:1. This condition provides the greatest accuracy for Power Meter measurements.

POWER METER

The operation of the Power Meter is simple. A load must be connected to the output jack of the Meter. Merely place the FUNCTION switch in either the 25- or 250-watt position; then read the corresponding scale on the meter scale to obtain the power output of the transmitter.

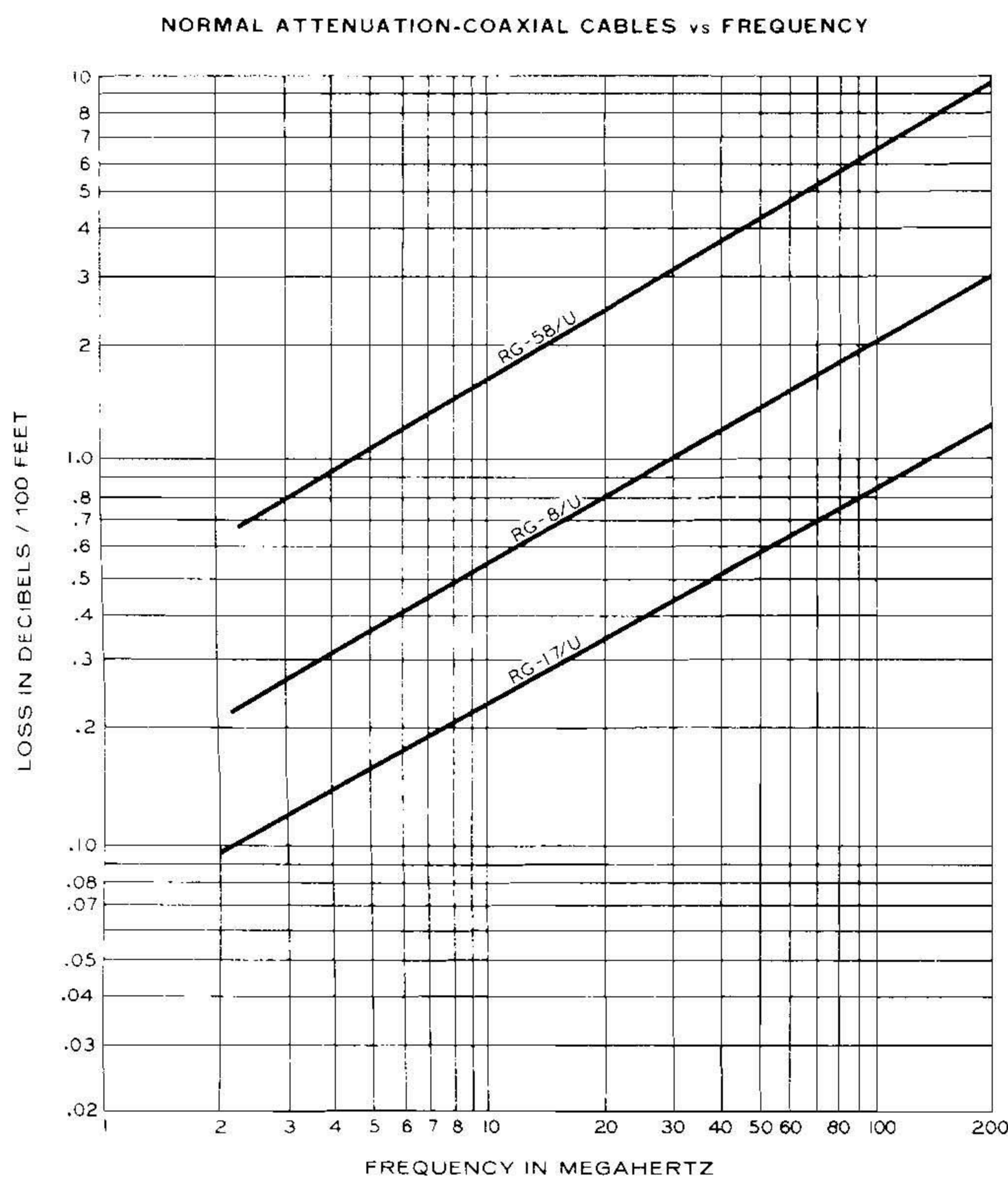

Figure 4

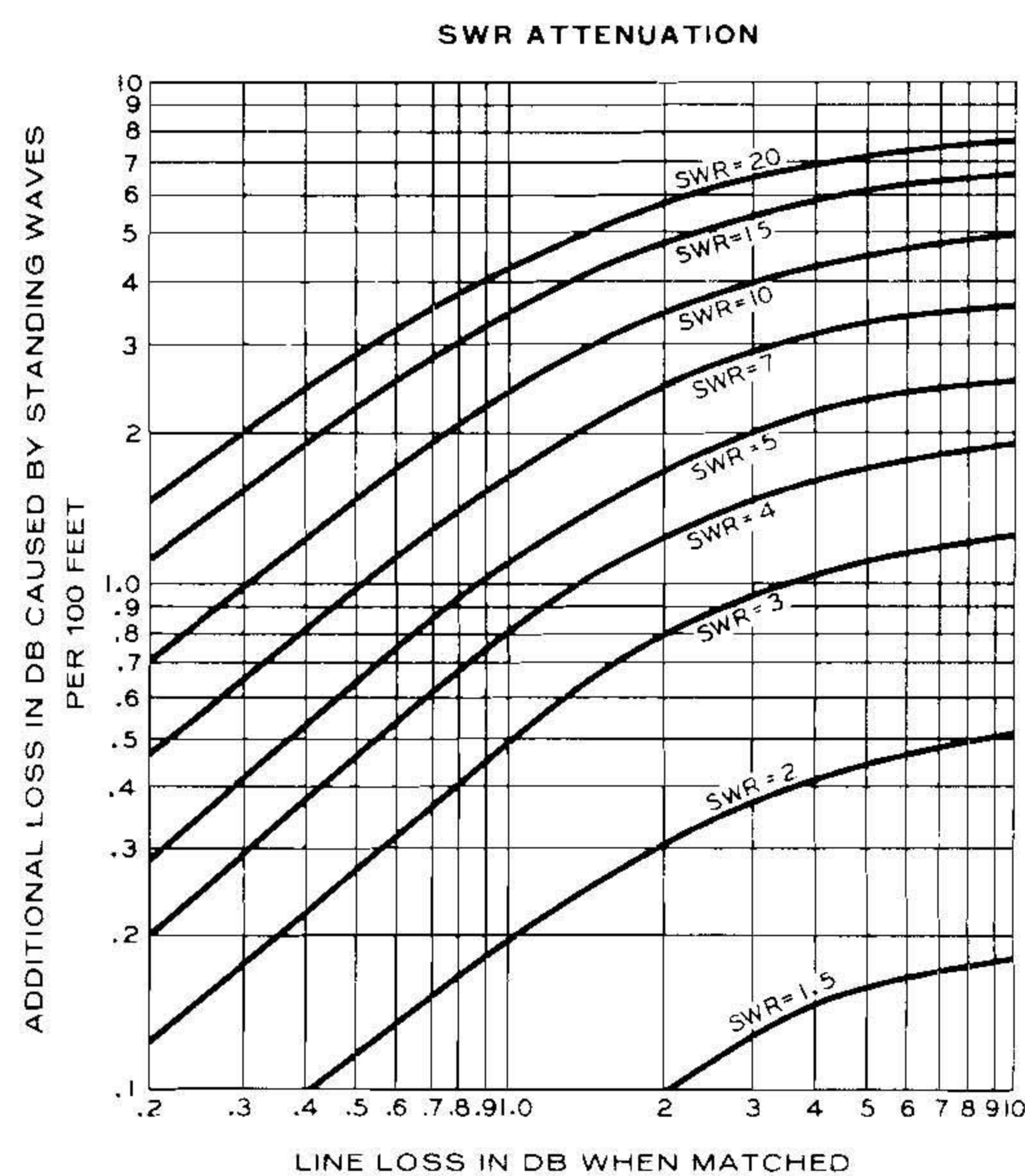

Figure 5

IN CASE OF DIFFICULTY

1. Recheck the wiring. Trace each lead in colored pencil on the Pictorial as it is checked. It is frequently helpful to have a friend check your work. Someone who is not familiar with the unit may notice something consistently overlooked by the constructor.
 2. It is interesting to note that about 90% of the kits that are returned for repair, do not function properly due to poor connections and soldering. Therefore, many troubles can be eliminated by reheating all connections to make sure that they are soldered as described in the "Soldering" section of the "Kit Builders Guide."
 3. Check the values of parts. Be sure that the proper part has been wired into the circuit, as shown in the Pictorial diagrams and as called out in the wiring instructions.
 4. Check for bits of solder, wire ends, or other foreign matter which may be lodged in the wiring.
 5. A review of the Circuit Description and the Schematic Diagram may prove helpful in locating a trouble.
- NOTE: In an extreme case where you are unable to resolve a difficulty, refer to the "Customer Service" information inside the rear cover of the Manual. Your Warranty is located inside the front cover .

Troubleshooting Chart

PROBLEM	POSSIBLE CAUSE
Meter reads down-scale on SWR or wattmeter.	<ol style="list-style-type: none"> 1. Meter leads reversed. 2. Diode D1 or D2 reversed.
Lower meter reading for SWR Set (switch out) than for SWR.	<ol style="list-style-type: none"> 1. Input and output plugs reversed. 2. Pickup coil L1 leads reversed. 3. Switch S3 incorrectly wired.
Calibrator portion of meter not functioning correctly.	<ol style="list-style-type: none"> 1. Input and output plugs reversed. 2. Diode D1 reversed. 3. Capacitor C1, C2, or C9. 4. Resistor R1.
SWR reading while transmitter is off.	<ol style="list-style-type: none"> 1. Nearby transmitter in operation.
SWR null not correct.	<ol style="list-style-type: none"> 1. Improper load on wattmeter. 2. Pickup coil L1 leads reversed. 3. C3 improperly connected.
No meter reading.	<ol style="list-style-type: none"> 1. Shorting wire not removed.



SPECIFICATIONS

Frequency Range	50 MHz to 160 MHz.
Wattmeter Accuracy	±10% of full-scale reading.*
Power Capability	To 250 watts.
SWR Sensitivity	Less than 10 watts.
Transmission Line Impedance	50 ohms nominal.
SWR Bridge	Continuous to 250 watts.
Connectors	UHF type SO-239.
Dimensions	5-1/4" wide, 5-1/16" high, and 6-1/2" deep, assembled as one unit.
Net Weight	2-1/2 lbs.

*Using a 50 Ω noninductive load.

The Heath Company reserves the right to discontinue instruments and to change specifications at any time without incurring any obligation to incorporate new features in instruments previously sold.

CIRCUIT DESCRIPTION

Refer to the Schematic while reading this "Circuit Description."

SWR BRIDGE CIRCUIT

Toroid coil L1 is a current pickup element for forward and reflected power. A bus wire is routed from the Input jack through toroid coil L1, and then to the Output jack. A transmitted signal routed along this wire induces a current in coil L1. The voltage formed in coil L1 is rectified by diode D3 and decoupled by capacitor C7 and resistor R4. Reverse power readings are determined, in the same manner, by the circuit consisting of diode D2, capacitor C8, and resistor R5.

Forward and reverse voltages are connected to the meter through switch S2, Sensitivity control R9, and Function switch S3.

Resistor R2 is a ground-return path for diodes D2 and D3. Capacitors C3, C4, C5, and C6 form a voltage divider circuit to balance the capacitive effects of the bifilar (doubled) windings in coil L1, which provides correct SWR readings.

POWER METER CIRCUIT

Current is induced in toroid coil L1 in the same manner as for the SWR bridge circuit. Resistor R3 forms a load across coil L1 to reduce the Q of the coil circuit. This prevents the transmitted frequency from affecting the wattmeter.

The wattmeter is calibrated by measuring the voltage at control R6, which varies the current going to the meter. Resistors R7 and R8 are voltage dividers for the two power ranges: 25 watts and 250 watts.

Capacitors C1 and C2, diode D1, and voltage divider resistor R1 through the calibrate jumper complete a voltmeter circuit for the wattmeter calibration.

Ferrite beads L2 through L6 prevent RF from traveling through the cable into the readout circuits.

CIRCUIT BOARD X-RAY VIEW

NOTE: To identify a part shown in this View, so you can order a replacement, proceed in either of the following ways:

1. A. Refer to the place where the part is installed in the Step-by-Step instructions and note the "Description" of the part (for example: 2200 Ω , .005 μF .).
- B. Look up this Description in the "Parts List."
2. A. Note the identification number of the part (R-number, C-number, etc.).
- B. Locate the same identification number (next to the part) on the Schematic. The "Description" of the part will also appear near the part.
- C. Look up this Description in the "Parts List."

(Viewed from foil side)

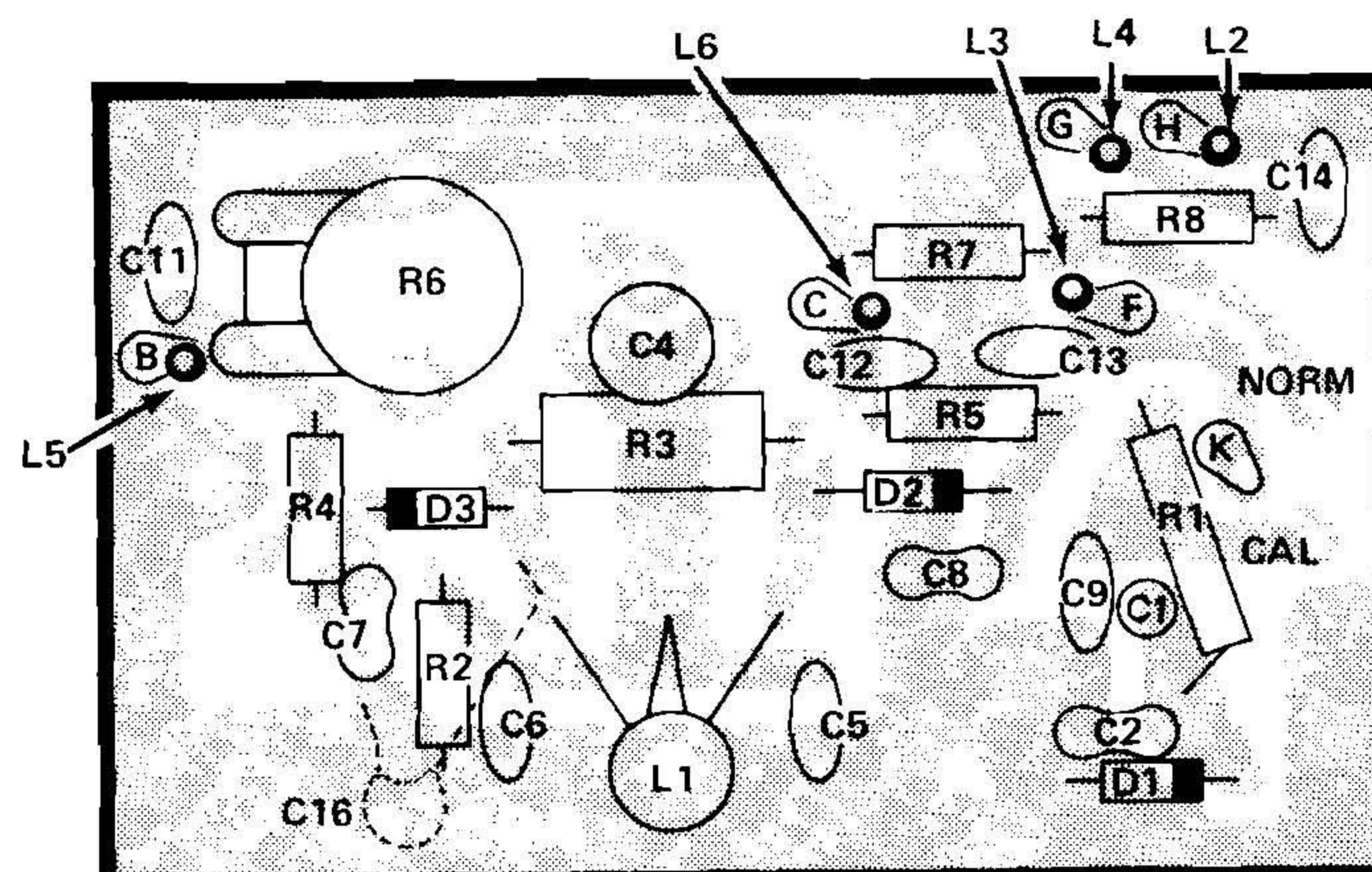

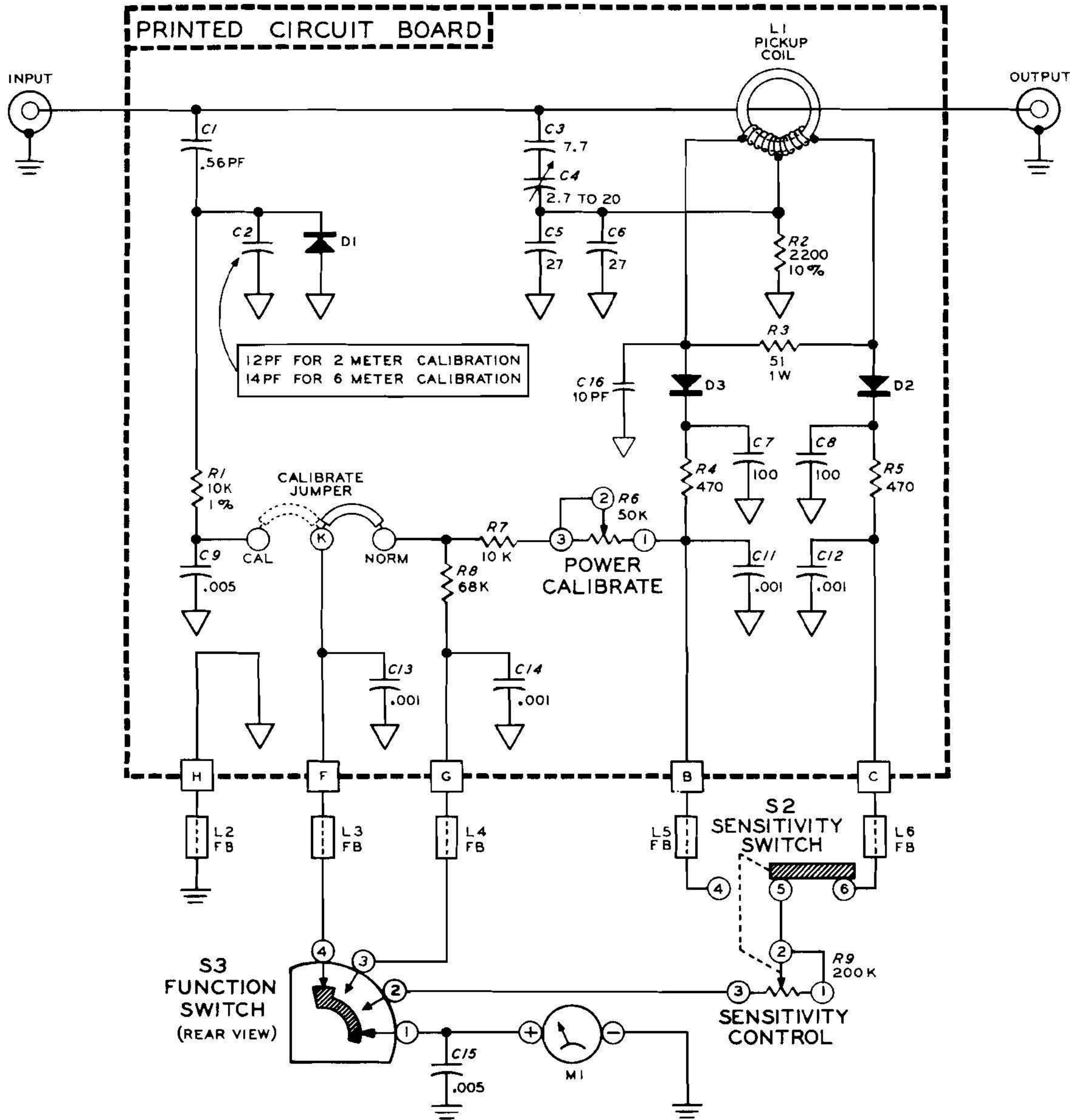

**SCHEMATIC OF THE
HEATHKIT®
VHF WATTMETER
MODEL HM-2102**

NOTES:

- | | |
|--|--|
| <p>1. ALL RESISTORS ARE 1/2 WATT 5% UNLESS OTHERWISE NOTED. RESISTOR VALUES ARE IN OHMS (K=1000).</p> <p>2. ALL CAPACITORS LESS THAN 1 ARE IN μF; GREATER THAN 1 ARE IN pF.</p> <p>3. FUNCTION SWITCH SHOWN IN 25 POSITION.</p> <p>4. SENSITIVITY SWITCH SHOWN PUSHED IN.</p> | <p>5. THIS SYMBOL INDICATES CIRCUIT BOARD COMMON.</p> <p>6. THIS SYMBOL INDICATES CHASSIS GROUND.</p> <p>7. THIS SYMBOL INDICATES AN EXTERNAL CONNECTION TO THE CIRCUIT BOARD.</p> <p>8. THIS SYMBOL INDICATES A FERRITE BEAD.</p> |
|--|--|

REMOTE CHASSIS PHOTOGRAPH

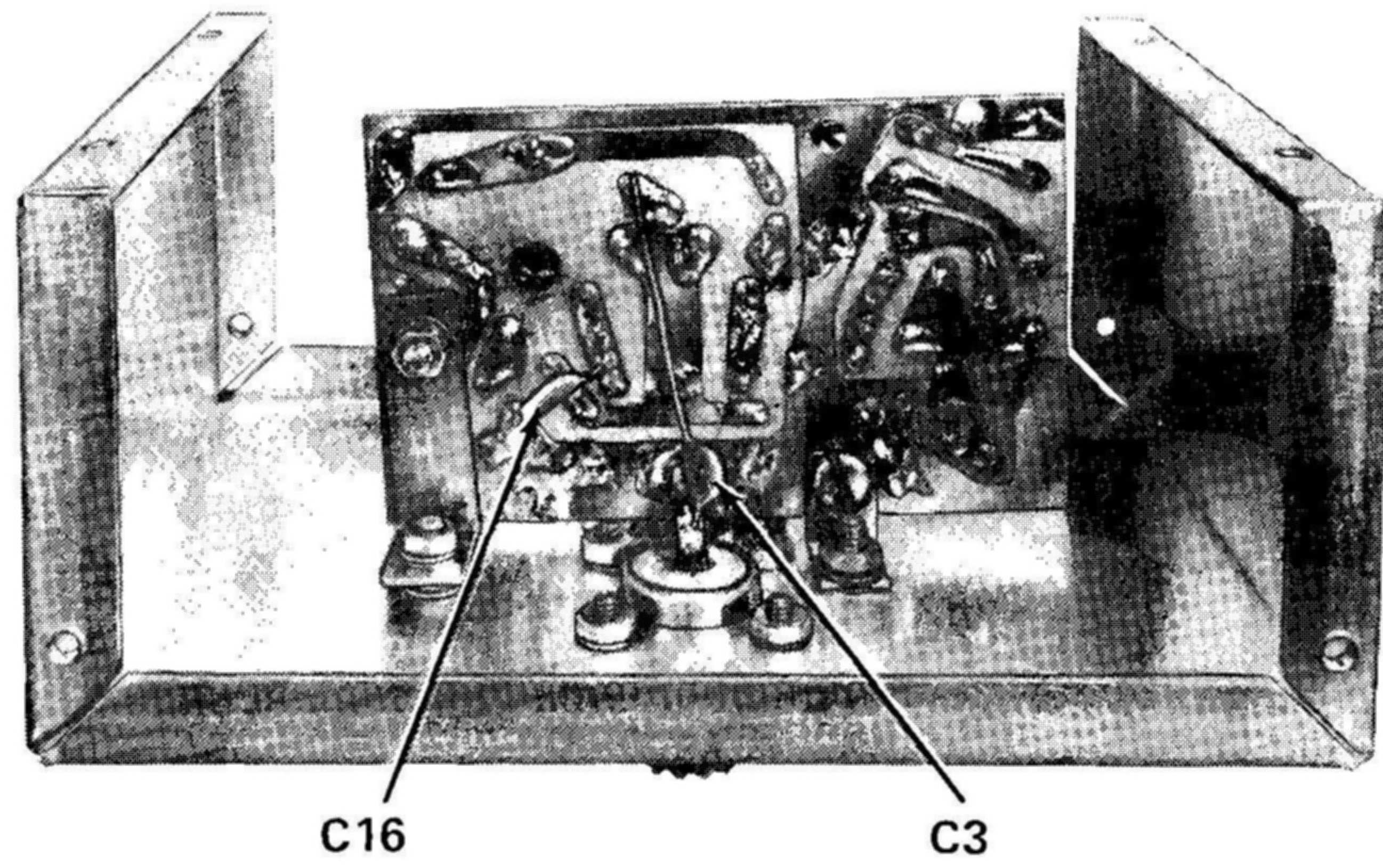

CABINET PHOTOGRAPH

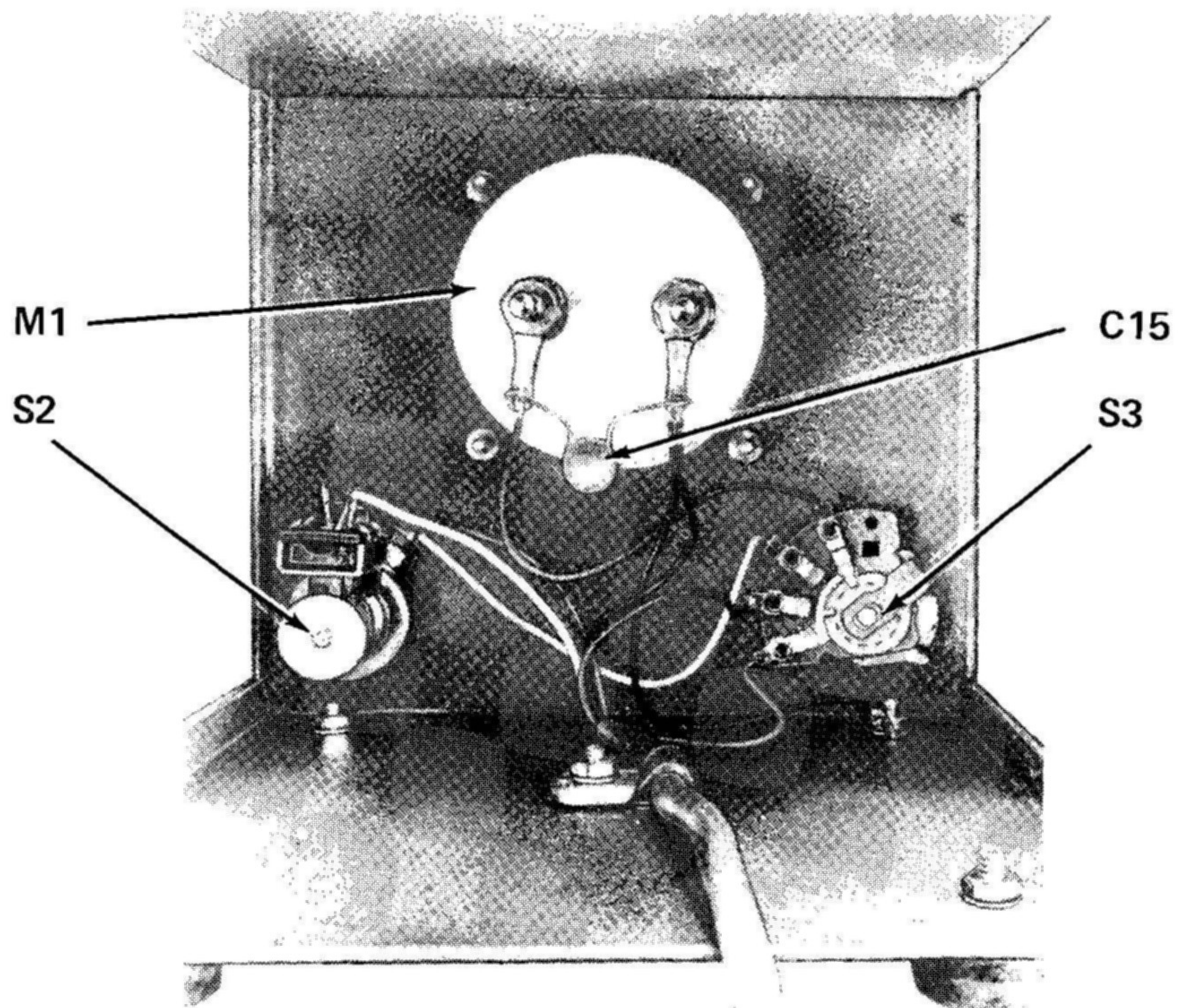

EXPEDITED PARTS ORDER FORM (FOR REPAIR PARTS ONLY)					PLEASE DO NOT WRITE IN THIS SPACE		
NAME _____					SEND TO: HEATH COMPANY BENTON HARBOR, MICHIGAN 49022 ATTN PARTS REPLACEMENT		
ADDRESS _____							
CITY _____ STATE _____ ZIP _____							
KIT MODEL	PURCHASE DATE	INVOICE NUMBER	LOCATION PURCHASED				
QTY.	HEATH PART NUMBER	DESCRIPTION OF PART			PRICE	TOTAL PRICE	DESIRED METHOD OF SHIPMENT
							EDITORS INITIALS
INSTRUCTIONS: <ul style="list-style-type: none"> ● INCLUDE CHECK OR MONEY ORDER FOR TOTAL PARTS ORDERED ADD 10% (MINIMUM \$0.25) FOR INSURANCE, POSTAGE AND HANDLING. ● AUTHORIZE PERMISSION FOR C.O.D. SHIPMENT (MINIMUM ORDER SHIPPED C.O.D. IS \$10.00). ● MICHIGAN RESIDENTS ADD 4% SALES TAX 					C.O.D. AUTHORIZATION _____ SIGNED		

THIS FORM IS FOR U.S. CUSTOMERS ONLY. OVERSEAS CUSTOMERS SEE YOUR DISTRIBUTOR.

----- CUT ALONG DOTTED LINE -----

EXPEDITED PARTS ORDER FORM (FOR REPAIR PARTS ONLY)					PLEASE DO NOT WRITE IN THIS SPACE		
NAME _____					SEND TO: HEATH COMPANY BENTON HARBOR, MICHIGAN 49022 ATTN PARTS REPLACEMENT		
ADDRESS _____							
CITY _____ STATE _____ ZIP _____							
KIT MODEL	PURCHASE DATE	INVOICE NUMBER	LOCATION PURCHASED				
QTY.	HEATH PART NUMBER	DESCRIPTION OF PART			PRICE	TOTAL PRICE	DESIRED METHOD OF SHIPMENT
							EDITORS INITIALS
INSTRUCTIONS: <ul style="list-style-type: none"> ● INCLUDE CHECK OR MONEY ORDER FOR TOTAL PARTS ORDERED ADD 10% (MINIMUM \$0.25) FOR INSURANCE, POSTAGE AND HANDLING. ● AUTHORIZE PERMISSION FOR C.O.D. SHIPMENT (MINIMUM ORDER SHIPPED C.O.D. IS \$10.00). ● MICHIGAN RESIDENTS ADD 4% SALES TAX 					C.O.D. AUTHORIZATION _____ SIGNED		

THIS FORM IS FOR U.S. CUSTOMERS ONLY. OVERSEAS CUSTOMERS SEE YOUR DISTRIBUTOR.

CUSTOMER SERVICE

REPLACEMENT PARTS

If you need a replacement part, please fill in the Parts Order Form that is furnished and mail it to the Heath Company. Or, if you write a letter, include the:

- Part number and description as shown in the Parts List.
- Model number and Series number from the blue and white label.
- Date of purchase.
- Nature of the defect.

Please do not return parts to the factory unless they are requested. Parts that are damaged through carelessness or misuse by the kit builder will not be replaced without cost, and will not be considered in warranty.

Parts are also available at the Heathkit Electronic Centers listed in your catalog. Be sure to provide the Heath part number. Bring in the original part when you request a warranty replacement from a Heathkit Electronic Center.

NOTE: Replacement parts are maintained specifically to repair Heathkit products. Parts sales for other reasons will be declined.

TECHNICAL CONSULTATION

Need help with your kit? Self-Service? Construction? Operation? Call or write for assistance. You'll find our Technical Consultants eager to help with just about any technical problem except "customizing" for unique applications.

The effectiveness of our consultation service depends on the information you furnish. Be sure to tell us:

- The Model number and Series number from the blue and white label.
- The date of purchase.
- An exact description of the difficulty.
- Everything you have done in attempting to correct the problem.

Also include switch positions, connections to other units, operating procedures, voltage readings, and any other information you think might be helpful.

Please do not send parts for testing, unless this is specifically requested by our Consultants.

Hints: Telephone traffic is lightest at midweek. . . please be sure your Manual and notes are on hand when you call.

Heathkit Electronic Center facilities are also available for telephone or "walk-in" personal assistance.

REPAIR SERVICE

Service facilities are available, if they are needed, to repair your completed kit. (Kits that have been modified, soldered with paste flux or acid core solder, cannot be accepted for repair.)

If it is convenient, personally deliver your kit to a Heathkit Electronic Center. For warranty parts replacement, supply a copy of the invoice or sales slip.

If you prefer to ship your kit to the factory, attach a letter containing the following information directly to the unit:

- Your name and address.
- Date of purchase.
- Copies of all correspondence relevant to the service of the kit.
- A brief description of the difficulty.
- Authorization to return your kit C.O.D. for the service and shipping charges. (This will reduce the possibility of delay.)

Check the equipment to see that all screws and parts are secured. (Do not include any wooden cabinets or color television picture tubes, as these are easily damaged in shipment.) Place the equipment in a strong carton with at least **THREE INCHES** of *resilient* packing material (shredded paper, excelsior, etc.) on all sides. Use additional packing material where there are protrusions (control sticks, large knobs, etc.). If the unit weighs over 15 lbs., place this carton in another one with 3/4" of packing material between the two.

Seal the carton with reinforced gummed tape, tie it with a strong cord, and mark it "Fragile" on at least two sides. Remember, the carrier will not accept liability for shipping damage if the unit is insufficiently packed. Ship by prepaid express, United Parcel Service, or insured Parcel Post to:

Heath Company
Service Department
Benton Harbor, Michigan 49022

HEATH

Schlumberger

HEATH COMPANY • BENTON HARBOR, MICHIGAN

THE WORLD'S FINEST ELECTRONIC EQUIPMENT IN KIT FORM

LITHO IN U.S.A.

Free Manual

Not to be resold

**Technology
Systems**

**PLEASE REPORT VOILATIONS TO
WWW.TECH-SYSTEMS-LABS.COM**