

## SPECIFICATIONS

Frequency Coverage, . . . . .	100 kc to at least 30 mc, in harmonics of 100 kc.
Crystal -	
Type, . . . . .	Quartz, fundamental frequency.
Frequency, . . . . .	100 kc $\pm$ .005%.
Pin Spacing, . . . . .	.486".
Pin Size, . . . . .	.050".
Tube, . . . . .	6BA6.
Power Requirements -	
B+ Voltage, . . . . .	150 volts, 1.7 milliamperes.
Filament Voltage, . . . . .	6.3 volts, .3 ampere.
Dimensions, . . . . .	2-1/8" x 2-1/8" x 3-1/8" from chassis.
Net Weight, . . . . .	5 oz.
Shipping Weight, . . . . .	1 lb.



## INTRODUCTION

Your HEATHKIT Model HRA-10-1 Crystal Calibrator is an accurate signal source which provides output signals at 100 kc intervals up to 30 mc.

The HRA-10-1 can be used for many purposes such as checking receiver dial calibration, checking band limits, and receiver

RF alignment.

The Calibrator was designed primarily to be used with the HEATHKIT HR-10 Amateur-Band Receiver, however, it can be used with most any other amateur receiver that provides the necessary operating voltages as listed in the Specifications.

## CIRCUIT DESCRIPTION

The Crystal Calibrator uses a 6BA6 tube in a crystal-controlled oscillator circuit. A 100 kc crystal is used to provide a stable 100 kc signal. Harmonic frequencies appear at each 100 kc up to 30 mc.

Ceramic trimmer capacitor C2 is used in series with the crystal to adjust the fundamental crystal frequency to exactly 100 kc. The output signal of the Calibrator is coupled through capacitor C3 to the antenna circuit of the receiver.

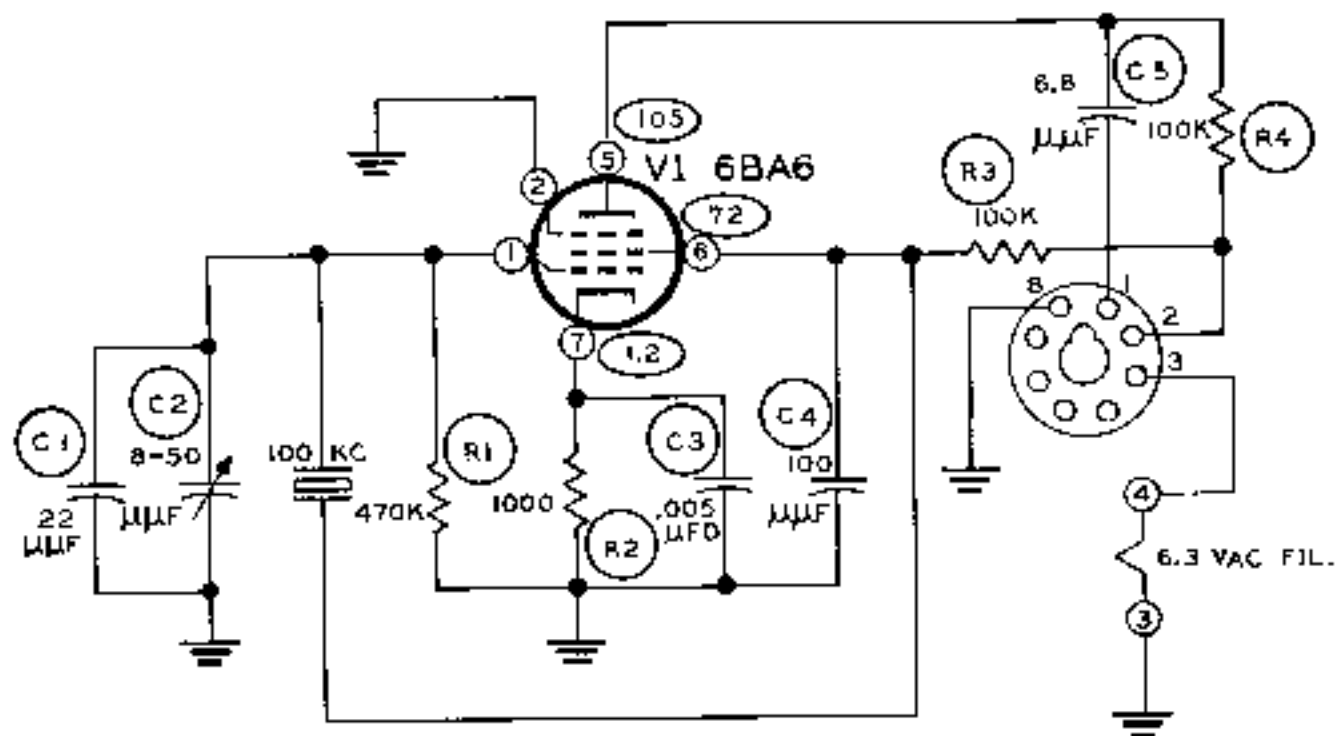

SCHEMATIC OF THE  
HEATHKIT®  
CRYSTAL CALIBRATOR  
MODEL HRA-10-1

ALL VOLTAGES MEASURED FROM POINT  
SHOWN TO CIRCUIT GROUND, WITH 11  
MEG OHM INPUT VTVM.  
ALL RESISTOR VALUES IN OHMS,  
K = 1,000, M = 1,000,000.

## PARTS LIST

Unpack the kit carefully and check each part against the Parts List. The numbers in front of the Part Number correspond to the picture of that part for quick and positive identification.

PART No.	PARTS Per Kit	DESCRIPTION
----------	---------------	-------------

Resistors

1-9	1	1000 $\Omega$ 1/2 watt (brown-black-red)
1-26	2	100 K $\Omega$ 1/2 watt (brown-black-yellow)
1-33	1	470 K $\Omega$ 1/2 watt (yellow-violet-yellow)

①

Capacitors

20-99	1	22 $\mu$ mf resin dipped mica
20-102	1	100 $\mu$ mf resin dipped mica
21-81	1	6.8 $\mu$ mf disc ceramic
21-27	1	.005 $\mu$ fd disc ceramic
31-27	1	8-50 $\mu$ mf ceramic trimmer

②



③



④

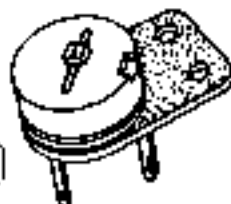

PART No.	PARTS Per Kit	DESCRIPTION
----------	---------------	-------------

Hardware

(1) 250-4	1	4-40 x 3/8" screw
(2) 250-49	5	3-48 x 1/4" screw
(3) 250-58	8	6-32 x 1/4" screw

⑤



⑥



⑦



(8) 252-1	5	3-48 nut
(9) 252-15	1	4-40 nut
(10) 254-1	8	#6 lockwasher
(11) 254-7	7	#3 lockwasher
(12) 254-9	1	#4 lockwasher

⑧



⑨



⑩



⑪



⑫



(13) 255-11	4	Tapped spacer
(14) 259-8	1	#6 small solder lug
(15) 260-29	1	Crystal holding clip
435-1	1	Octal socket mounting ring

⑬

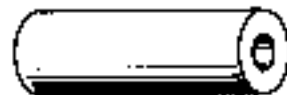

⑭



⑮



<u>PART No.</u>	<u>PARTS Per Kit</u>	<u>DESCRIPTION</u>
<u>Wire</u>		
340-8	1	Length bare wire
344-1	1	Length hookup wire



Terminal Strips-Sockets-Plugs

431-38	1	8-lug miniature terminal strip
434-34	1	7-pin tube socket
434-74	1	Crystal socket
438-6	1	Octal plug

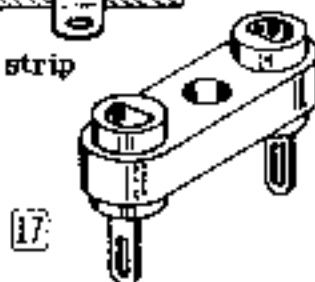

<u>PART No.</u>	<u>PARTS Per Kit</u>	<u>DESCRIPTION</u>
<u>Miscellaneous</u>		
200-M342F684	1	Chassis
205-M346	1	Bottom plate
404-43	1	100 kc .005% tolerance crystal
411-90	1	6BA6 tube
331-6		Solder
595-525	1	Manual

## CONSTRUCTION NOTES

The following instructions are presented in a logical step-by-step sequence to enable you to complete your kit with the least possible confusion. Be sure to read each step all the way through before beginning the specified operation. Also read several steps ahead of the actual step being performed. This will familiarize you with the relationship of the subsequent operations. When the step is completed, check it off in the space provided. This is particu-

larly important as it may prevent errors or omissions, especially if your work is interrupted.

In general, the illustrations in this manual correspond to the actual configuration of the kit; however, in some instances the illustrations may be slightly distorted to facilitate clearly showing all of the parts.



The abbreviation "NS" indicates that a connection should not be soldered yet as other wires will be added. When the last wire is installed, the terminal should be soldered and the abbreviation "S" is used to indicate this. Note that a number will appear after each solder instruction. This number indicates the number of leads that are supposed to be connected to the terminal in point before it is soldered. For example, if the instruction reads, "Connect a lead to lug 1 (S-2)," it will be understood that there will be two leads connected to the terminal at the time it is soldered.

Position the work, if possible, so that gravity will help to keep the solder where you want it. The joint to be soldered should be heated with the flat side of the soldering iron tip sufficiently to melt the solder. Apply only enough solder to the heated terminal to thoroughly wet the junction. Remove the solder and then the iron when a smooth soldered junction appears. Do not move the leads until the solder is solidified.

ROSIN CORE SOLDER HAS BEEN SUPPLIED WITH THIS KIT. THIS TYPE OF SOLDER MUST BE USED FOR ALL SOLDERING IN THIS KIT. ALL GUARANTEES ARE VOIDED AND WE WILL NOT REPAIR OR SERVICE EQUIPMENT IN WHICH ACID CORE SOLDER OR PASTE FLUXES HAVE BEEN USED. IF ADDITIONAL SOLDER IS NEEDED, BE SURE TO PURCHASE ROSIN CORE (60:40 or 50:50 TIN-LEAD CONTENT) RADIO TYPE SOLDER.

## STEP-BY-STEP ASSEMBLY

Refer to Pictorial 1 for the following steps.

- ( ) Locate the chassis and position it as shown in Pictorial 1.

- ( ) Referring to Detail 1A, mount the 3-lug miniature terminal strip at location A. Use a 3-48 x 1/4" screw, #3 lockwashers, and a 3-48 nut.

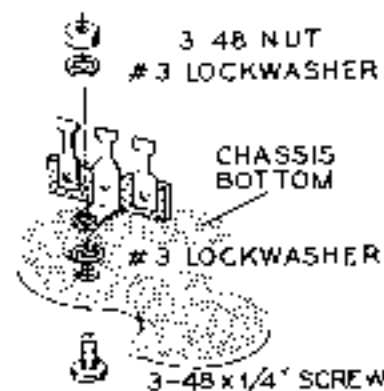

Detail 1A

- ( ) Mount the 7-pin tube socket at location V1 with a #6 small solder lug on one mounting screw. Use 3-48 x 1/4" screws, #3 lockwashers, and 3-48 nuts. See Detail 1B. Position the blank space as shown.

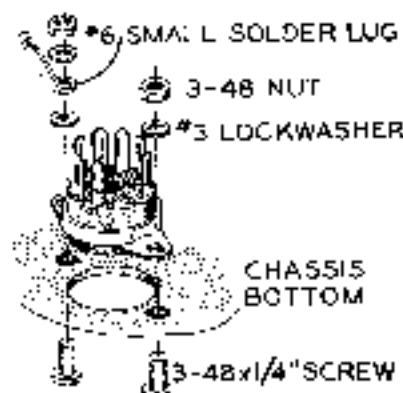

Detail 1B

- ( ) C2. Referring to Detail 1C, mount the ceramic trimmer capacitor at location B. Use 3-48 x 1/4" screws, #3 lockwashers and 3-48 nuts.

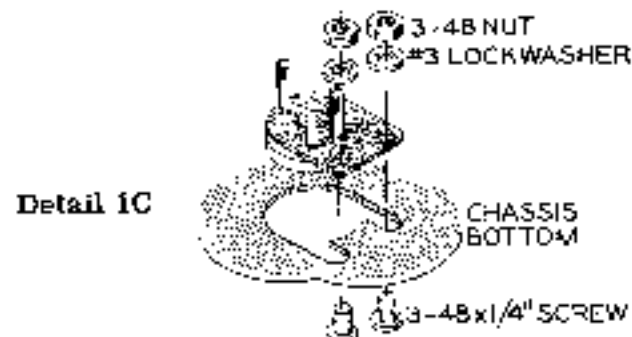

Detail 1C

- ( ) Mount the crystal socket and crystal clip at location C. Use a 4-40 x 3/8" screw, #4 lockwasher, and a 4-40 nut. See Detail 1D. Do not overtighten the hardware or you may crack the crystal socket.

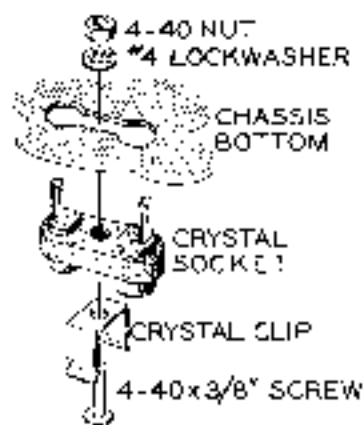

Detail 1D

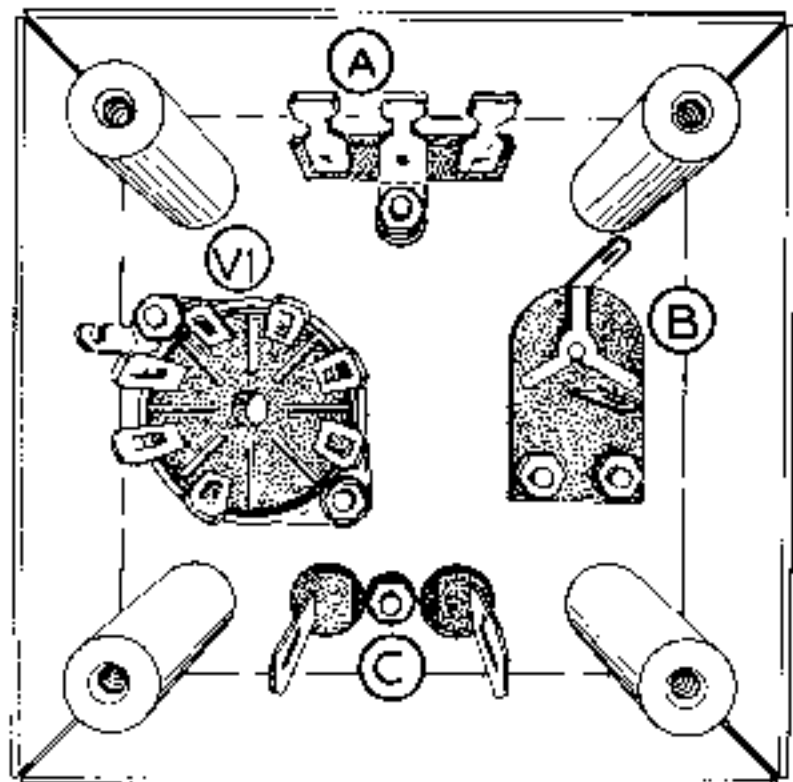

Pictorial 1

- ( ) Referring to Detail 1E, mount a tapped spacer in each corner of the chassis. Use 6-32 x 1/4" screws and #6 lockwashers.

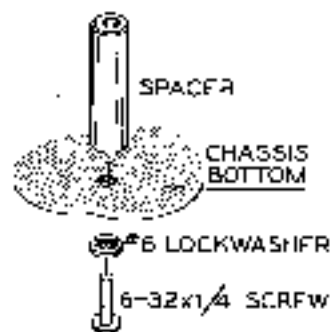

Detail 1E

- ( ) Locate the bottom plate and referring to Pictorial 2, mount the octal plug. Secure the plug with the octal plug retaining ring. Position the keyway as shown in Pictorial 2.

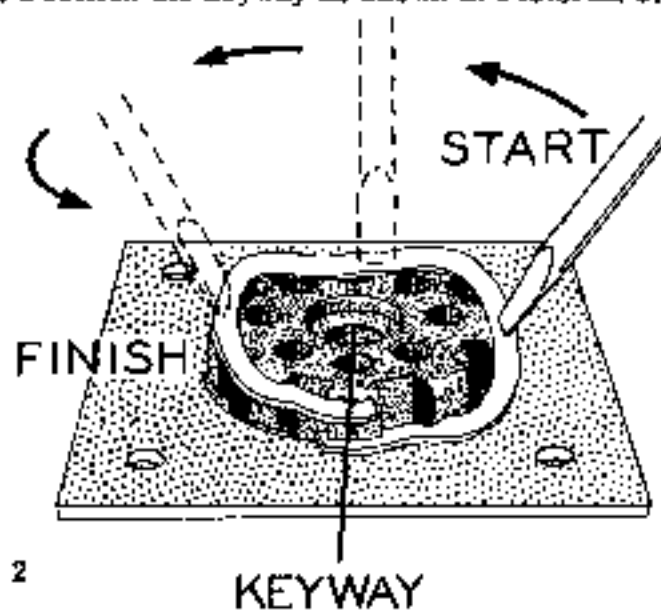

Pictorial 2



Refer to Pictorial 3 for the following steps.

- (X) C1. Place one lead of a 22  $\mu\text{f}$  resin dipped mica capacitor through lug 1 of trimmer capacitor B (NS) and connect it to lug 2 of terminal strip A (NS). Now solder lug 1 of B (S-2). Connect the other lead of this capacitor to lug 2 of B (NS).
- (X) Place one end of a length of bare wire through lug 1 of crystal socket C (NS) and connect it to lug 2 of trimmer capacitor B (S-2). Now solder lug 1 of C (S-2). Connect the other end of this bare wire to lug 1 of tube socket V1 (NS).
- (X) Connect a 2" hookup wire from lug 6 of tube socket V1 (NS) to lug 2 of crystal socket C (S-1).
- (X) R1. Connect a 470 K $\Omega$  (yellow-violet-yellow) 1/2 watt resistor from lug 1 of tube socket V1 (S-2) to the solder lug nearest lug 3 of V1 (NS).
- (X) Place one end of a length of bare wire through lug 3 (NS) to lug 2 (S-1) of tube socket V1. Connect the other end of this wire to the solder lug nearest lug 3 of V1 (S-2).
- (X) R2, C3. Referring to Detail 3A, prepare a 1000  $\Omega$  (brown-black-red) 1/2 watt resistor and a .005  $\mu\text{f}$  disc ceramic capacitor combination.
- (X) Connect this resistor capacitor combination from lug 2 of terminal strip A (NS) to lug 7 of tube socket V1 (S-1).

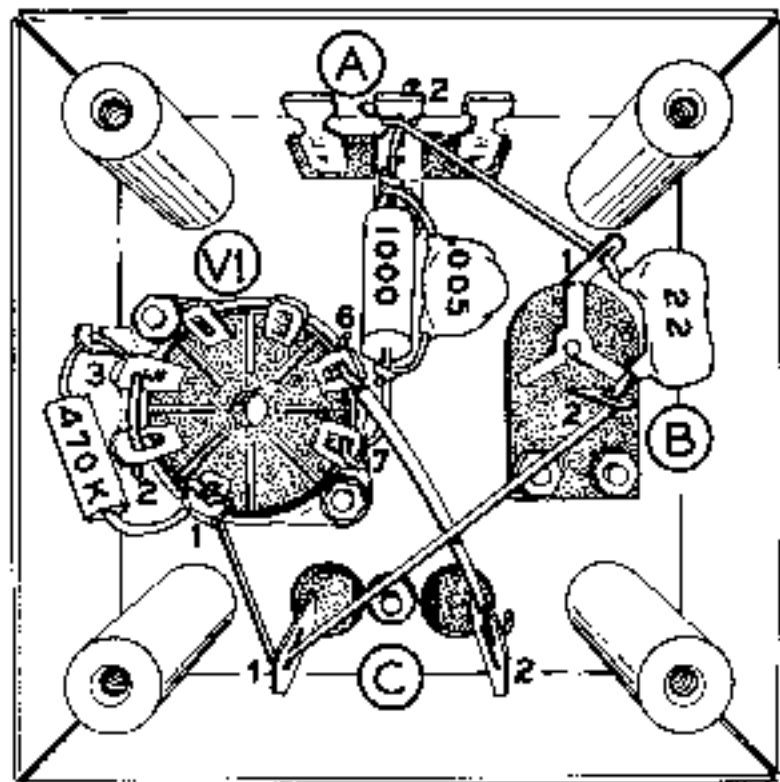

Pictorial 3



Detail 3A

Refer to Pictorial 4 for the following steps.

- (-) R4. Connect a 100 K $\Omega$  (brown-black-yellow) 1/2 watt resistor from lug 3 of terminal strip A (NS) to lug 5 of tube socket V1 (NS).
- (X) R3. Connect a 100 K $\Omega$  (brown-black-yellow) 1/2 watt resistor from lug 3 of terminal strip A (NS) to lug 5 of tube socket V1 (NS).
- (-) C5. Connect a 6.8  $\mu$ f disc ceramic capacitor from lug 5 of tube socket V1 (S-2) to lug 1 of terminal strip A (NS).
- (X) C4. Connect a 100  $\mu$ f resin dipped mica capacitor between lugs 3 (S-3) and 5 (S-3) of tube socket V1.

**NOTE:** In the following four steps, remove 1/4" of insulation from one end of each wire and 1/2" of insulation from the other end. Connect the ends stripped 1/2" to the octal plug as directed.

- (X) Connect a 2" wire from lug 2 of terminal strip A (S-3) to lug 8 of the octal plug (S-1).
- (-) Connect a 2-1/2" wire from lug 1 of terminal strip A (S-2) to lug 1 of the octal plug (S-1).
- (-) Connect a 3" wire from lug 3 of terminal strip A (S-3) to lug 2 of the octal plug (S-1).
- (-) Connect a 3" wire from lug 4 of tube socket V1 (S-1) to lug 3 of the octal plug (S-1).

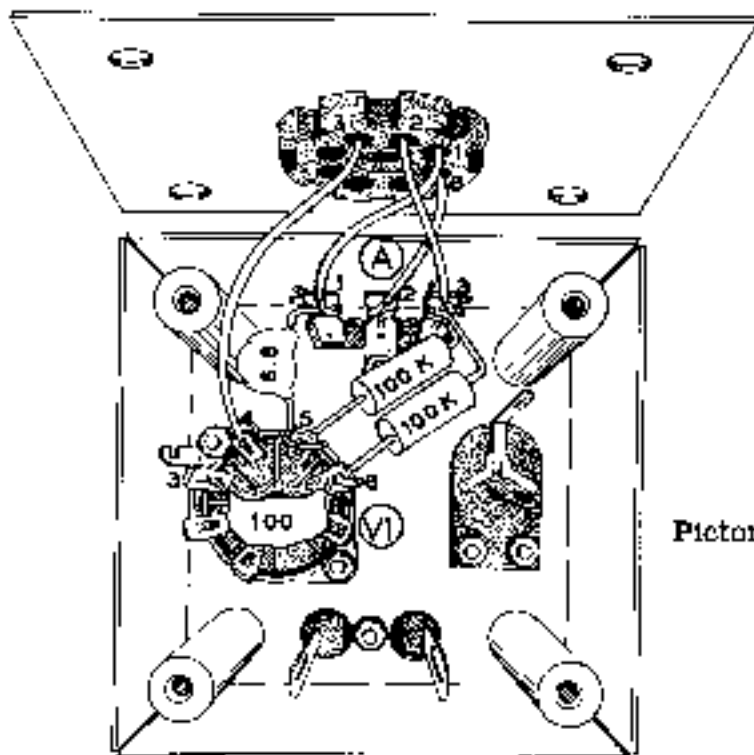

Pictorial 4

- (X) Fold the bottom plate over the bottom of the chassis and secure each corner with a 6-32 x 1/4" screw and #8 lock-washer.
- ( ) Install the 6BA6 in tube socket V1.
- ( ) Install the 100 kc crystal in the crystal socket.

This completes the assembly of the Crystal Calibrator.

## ADJUSTMENT

### USING THE HEATHKIT HRA-10-1 100 KC CRYSTAL CALIBRATOR

- ( ) Plug the calibrator into the Calibrator socket in the HR-10 Receiver.
- ( ) Couple the antenna connector of the HR-10 Receiver to the antenna connector of another receiver capable of receiving WWV at 2.5 mc, 5 mc, 10 mc, or 15 mc. If this is not possible, a receiver tuned to a standard Broadcast station, operating at an even multiple of 100 kc can be used.
- ( ) Turn on the HR-10 and the other receiver. Set the CAL switch of the HR-10 Receiver in the CAL position.
- ( ) Adjust the ceramic trimmer capacitor in the Calibrator

with an insulated screwdriver for "zero beat" during the period when no tone modulation is applied to the WWV carrier. (Zero beat will be recognized as the point at which a harmonic of 100 kc corresponds to the frequency of the station that is tuned in on the receiver. As zero beat is approached, a tone, decreasing in frequency until it finally stops, will be heard from the receiver speaker. To be sure you have zero beat, set the CAL switch to OFF and then back to CAL.

If a receiver other than the HR-10 is used for adjustment, the above procedure should still be followed.

This completes the adjustment of the HRA-10-1 Crystal Calibrator.

## OPERATION

Use with the HEATHKIT HR-10 Basic Amateur Band Receiver.

- ( ) Install the Crystal Calibrator in the Calibrator socket on the top of the Receiver chassis.
- ( ) Turn the Receiver on and allow it to warm up.
- ( ) Place the CAL switch in the CAL position. Set the BFO switch to BFO.

- ( ) Turn the MAIN TUNING control to a 100 kc point on the Receiver dial. A heterodyne should be heard in the speaker if the Receiver is in calibration. If the heterodyne is not heard, calibrate the Receiver by adjusting the CAL RESET control until the heterodyne is heard at the 100 kc points on the dial.

There are many other uses for a crystal calibrator, such as checking RF alignment, checking transmitter VFO accuracy, etc.

It would not be possible to cover all of these functions in detail here. Information concerning other uses of a crystal calibrator can be found in the ARRL Handbook (American Radio Relay League, West Hartford, Connecticut).

### USE WITH OTHER AMATEUR RECEIVERS

The HRA-10-1 Calibrator does not contain its own power supply,

therefore, it will be necessary for you to connect the B+ and filament circuits of the Calibrator to the appropriate points in your receiver. Also, it will be necessary for you to connect the output of the Calibrator to the antenna input of the receiver for signal injection. These connections are shown in the following Schematic Diagram. Notice that the B+ voltage is connected through a SPST switch so that the Calibrator can be turned On and Off independently of your receiver.

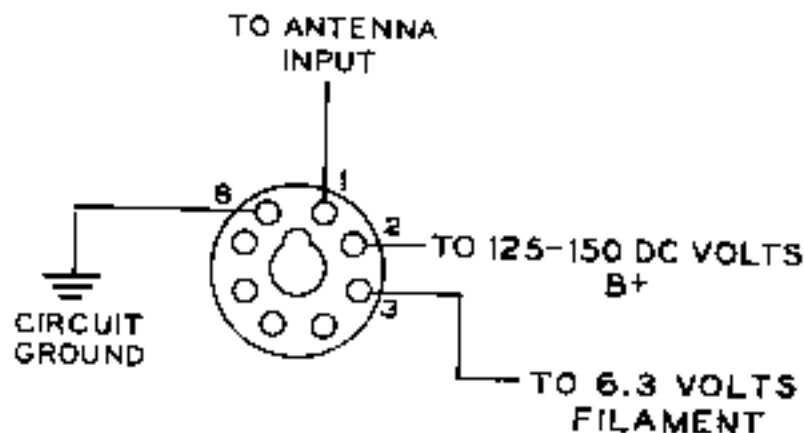

## IN CASE OF DIFFICULTY

1. Recheck the wiring. Trace each lead in colored pencil on the Pictorial as it is checked. It is frequently helpful to have a friend check your work. Someone who is not familiar with the unit may notice something consistently overlooked by the constructor.
2. It is interesting to note that about 90% of the kits that are returned for repair, do not function properly due to poor connections and soldering. Therefore, many troubles can be eliminated by reheating all connections to make sure that they are soldered as described in the Proper Soldering Techniques section of this manual.
3. Make sure that the tube lights up properly.
4. Check the tube with a tube tester or by substitution of a tube of the same type and known to be good.
5. Check the values of the parts. Be sure that the proper part has been wired into the circuit, as shown in the pictorial diagrams and as called out in the wiring instructions.
6. Check for bits of solder, wire ends or other foreign matter, which may be lodged in the wiring.
7. If, after careful checks, the trouble is still not located and a voltmeter is available, check voltage readings against those shown on the Schematic Diagram. NOTE: All voltage readings were taken with an 11 megohm input vacuum tube voltmeter. Voltages may vary as much as 10%.
8. A review of the Circuit Description will prove helpful in indicating where to look for trouble.

## SERVICE INFORMATION

### SERVICE

If, after applying the information in this manual and your best efforts, you are still unable to obtain proper performance, it is suggested that you take advantage of the technical facilities which the Heath Company makes available to its customers.

The Technical Consultation Department is maintained for your benefit. This service is available to you at no charge. Its primary purpose is to provide assistance for those who encounter difficulty in the construction, operation or maintenance of HEATHKIT equipment. It is not intended, and is not equipped to function as a general source of technical information involving kit

modifications nor anything other than the normal and specified performance of HEATHKIT equipment.

Although the Technical Consultants are familiar with all details of this kit, the effectiveness of their advice will depend entirely upon the amount and the accuracy of the information furnished by you. In a sense, YOU MUST QUALIFY for GOOD technical advice by helping the consultants to help you. Please use this outline:

1. Before writing, fully investigate each of the hints and suggestions listed in this manual under In Case Of Difficulty. Possibly it will not be necessary to write.
2. When writing, clearly describe the nature of the trouble and mention all associated equipment. Specifically report operating procedures, switch positions, connections to other units, and anything else that might help to isolate the cause of trouble.
3. Report fully on the results obtained when testing the unit initially and when following the suggestions under In Case Of Difficulty. Be as specific as possible and include voltage readings if test equipment is available.
4. Identify the kit model number and date of purchase if available. Also mention the date of the kit assembly manual. (Date at bottom of Page 1.)
5. Print or type your name and address, preferably in two places on the letter.

With the preceding information, the consultant will know exactly what kit you have, what you would like it to do for you and the difficulty you wish to correct. The date of purchase tells him whether or not engineering changes have been made since it was shipped to you. He will know what you have done in an effort to locate the cause of trouble and, thereby, avoid repetitious suggestions. In short, he will devote full time to the problem at hand, and through his familiarity with the kit, plus your accurate report, he will be able to give you a complete and helpful answer. If replacement parts are required, they will be shipped to you, subject to the terms of the Warranty.

The Factory Service facilities are also available to you, in case you are not familiar enough with electronics to provide our consultants with sufficient information on which to base a diagnosis of your difficulty, or in the event that you prefer to have the difficulty corrected in this manner. You may return the completed equipment to the Heath Company for inspection and necessary repairs and adjustments. You will be charged a minimal service fee, plus the price of any additional parts or material required. However, if the completed kit is returned within the Warranty period, parts charges will be governed by the terms of the Warranty. State the date of purchase, if possible.

Local Service by Authorized HEATHKIT Service Centers is also available in some areas and often will be your fastest, most efficient method of obtaining service for your HEATHKIT equipment. Although charges for local service are generally somewhat higher than for factory service, the amount of increase is usually offset by the transportation charge you would pay if you

elected to return your kit to the Heath Company.

HEATHKIT Service Centers will honor the regular 90 day HEATHKIT Parts Warranty on all kits, whether purchased through a dealer or directly from Heath Company; however, it will be necessary that you verify the purchase date of your kit.

Under the conditions specified in the Warranty, replacement parts are supplied without charge; however, if the Service Center assists you in locating a defective part (or parts) in your kit, or installs a replacement part for you, you may be charged for this service.

HEATHKIT equipment purchased locally and returned to Heath Company for service must be accompanied by your copy of the dated sales receipt from your authorized HEATHKIT dealer in order to be eligible for parts replacement under the terms of the Warranty.

**THIS SERVICE POLICY APPLIES ONLY TO COMPLETED EQUIPMENT CONSTRUCTED IN ACCORDANCE WITH THE INSTRUCTIONS AS STATED IN THE MANUAL.** Equipment that has been modified in design will not be accepted for repair. If there is evidence of acid core solder or paste fluxes, the equipment will be returned NOT repaired.

For information regarding modification of HEATHKIT equipment for special applications, it is suggested that you refer to any one or more of the many publications that are available on all phases of electronics. They can be obtained at or through your local library, as well as at most electronic equipment stores.

Although the Heath Company sincerely welcomes all comments and suggestions, it would be impossible to design, test, evaluate and assume responsibility for proposed circuit changes for special purposes. Therefore, such modifications must be made at the discretion of the kit builder, using information available from sources other than the Heath Company.

## REPLACEMENTS

Material supplied with HEATHKIT products has been carefully selected to meet design requirements and ordinarily will fulfill its function without difficulty. Occasionally, improper operation can be traced to a faulty component. Should inspection reveal the necessity for replacement, write to the Heath Company and supply all of the following information.

- A. Thoroughly identify the part in question by using the part number and description found in the manual Parts List.
- B. Identify the type and model number of kit in which it is used.
- C. Mention date of purchase.
- D. Describe the nature of defect or reason for requesting replacement.

The Heath Company will promptly supply the necessary replacement. PLEASE DO NOT RETURN THE ORIGINAL COMPONENT UNTIL SPECIFICALLY REQUESTED TO DO SO. Do not dismantle the component in question as this will void the



guarantee. This replacement policy does not cover the free replacement of parts that may have been broken or damaged through carelessness on the part of the kit builder.

### SHIPPING INSTRUCTIONS

In the event that your instrument must be returned for service, these instructions should be carefully followed. Be sure to include the crystal.

Wrap the equipment in heavy paper, exercising care to prevent damage. Place the wrapped equipment in a stout carton of such size that at least three inches of shredded paper, excelsior, or other resilient packing material can be placed between all sides of the wrapped equipment and the carton. Close and seal the carton with gummed paper tape, or alternately, tie securely

with stout cord. Clearly print the address on the carton as follows:

To: HEATH COMPANY  
Benton Harbor, Michigan

ATTACH A LETTER TO THE OUTSIDE OF THE CARTON BEARING YOUR NAME, COMPLETE ADDRESS, DATE OF PURCHASE, AND A BRIEF DESCRIPTION OF THE DIFFICULTY ENCOUNTERED. Also, include your name and return address on the outside of the carton. Preferably affix one or more "Fragile" or "Handle With Care" labels to the carton, or otherwise so mark with a crayon of bright color. Ship by insured parcel post or prepaid express; note that a carrier cannot be held responsible for damage in transit if, in HIS OPINION, the article is inadequately packed for shipment.