

OPERATION AND ALIGNMENT OF THE 100-139 TUNER ASSEMBLY FOR THE HEATHKIT "MOHAWK" COMMUNICATIONS RECEIVER, RX-1



TUNER SPECIFICATIONS

Frequency Coverage:	<u>Band (meters)</u>	<u>Frequency</u>
	160	1.8 - 2.0 mc
	80	3.5 - 4.0 mc
	40	7.0 - 7.3 mc
	20	14.0 - 14.35 mc
	15	21.0 - 21.45 mc
	11	26.96 - 27.23 mc
	10	28.0 - 29.7 mc
	Conv	22.0 - 26.0 mc

Front Panel Controls:	Main tuning capacitor. Antenna tuning capacitor. Calibration capacitor.
Tube Complement:	6BZ6 - RF Amplifier. 6CS6 - 1st Mixer. 12AT7 - Oscillator-Cathode Follower.
Output Frequency:	1682 kc.
Power Requirements:	B+ 225 volts at 13.5 ma. 150 volts regulated at 4.8 ma. Filaments 6.3 volts at 900 ma.
Weight:	8 lbs.
Shipping Weight:	8 1/2 lbs.
Size:	10 1/2" deep x 8 7/8" wide x 6 1/2" high.

INTRODUCTION

To insure the top quality performance and reliability of the "Mohawk" Model RX-1 Communications Receiver, the factory-built 100-139 Tuner Assembly is supplied aligned and calibrated.

This manual has been prepared for those owners who feel that after extended use, realignment would improve the performance of their receivers. The tuner assemblies are optimized and must meet exacting standards prior to their shipping. However, the occasion may arise where the tuner assembly is damaged or detuned during shipment or during subsequent operation. If this condition should arise during the Warranty period, it is recommended that the tuner assembly be returned to the Heath Company under its Warranty. The Tuner Assembly Warranty is void if the owner attempts realignment of the unit during the Warranty period.

Realignment of the 100-139 Tuner Assembly is not difficult IF the owner has the proper equipment and carefully follows the Step-By-Step alignment procedure. Do not attempt to realign this assembly until you have read and thoroughly understand the Step-By-Step procedure.

CIRCUIT DESCRIPTION

RF AMPLIFIER

A 6BZ6 tube is used as the radio frequency amplifier stage. This stage has delayed AVC applied and a separate gain control operating in the cathode circuit. By independently controlling the gain of this stage, it is possible to reduce cross modulation from extremely strong signals, and yet maintain good overall sensitivity.

Eight high-Q ceramic form coils and four sections of the band switch are enclosed in the RF compartment. The antenna windings of the coils have grounded center taps, with the two ends switched for band changing. The entire antenna winding is used with balanced antennas of 100-150 ohm impedances, and because of the center tap construction, noise pickup in the feeders is cancelled. Half of the antenna winding is used for coaxial feed lines of 50 to 75 ohms impedance. A front panel antenna trimmer control peaks the circuit for various antennas.

1ST MIXER

A 6CS6 tube, which has dual grid control and sharp cutoff characteristics, is used as the 1st mixer. This tube, although not primarily designed for mixer service, has proved to have equal conversion transconductance and considerably less mixer noise than many others tested. Its basic configuration is similar to the 6BE6, but is a high gain tube with less noise.

Here again, the coils and the necessary sections of the band switch are isolated in a separate compartment. In each compartment, one section of the band switch switches the main tuning capacitor sections to place either the larger or smaller sections, or both, in parallel with the circuit, to provide the proper bandspread for each band.

The output of the mixer is carried through a coaxial cable to the 1682 kc IF chassis.

1ST CONVERSION OSCILLATOR

A 12AT7 twin triode tube combines the functions of a Hartley oscillator and a cathode follower. By using half the tube as a cathode follower to couple the oscillator to the mixer stage, oscillator "pulling" is eliminated.

A 20 $\mu\mu\text{f}$ variable capacitor is connected to the oscillator coil cathode tap and is used to calibrate the dial to the 100 kc built-in crystal oscillator.

The oscillator coils and band switch sections are isolated in the front end section of the tuner assembly.

The complete tuner assembly, including RF amplifier, mixer and oscillator, is furnished completely wired and aligned. This unit is connected to the rest of the receiver by appropriate plugs and cables, and to the panel controls through mechanical linkage.

STEP-BY-STEP ALIGNMENT PROCEDURE

NOTE: In order to accurately align the "Mohawk" Receiver Tuner Assembly, a known frequency signal is required for each band to be realigned. With a known frequency signal and the built-in 100 kc crystal calibrator, there are sufficient checkpoints to check the tracking from the bottom to the top of each band.

The following Block Diagram shows the equipment setup required.

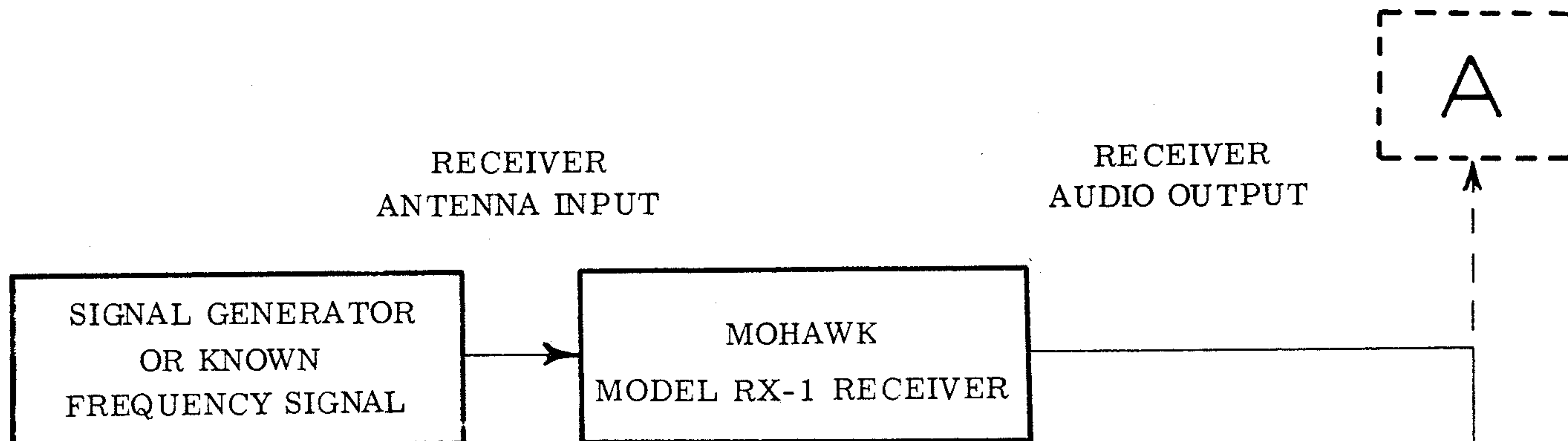

Figure 1

NOTE: TO MONITOR RECEIVER OUTPUT LEVEL FOR MAXIMUM INDICATION, WHERE CALLED FOR IN THE STEP-BY-STEP INSTRUCTIONS, USE THE BUILT IN S-METER A, OR USE AN AUDIO OUTPUT METER ACROSS THE SPEAKER TERMINALS AS IN B.

- () During the alignment of any band the receiver should be placed on a sheet of metal so that the bottom of the tuner assembly is completely covered. This will establish the same condition that exists when the unit is in its cabinet, and has a definite affect on the alignment. See Figure 2.

NOTE: Recheck the next step (taken from Page 47 of the "Mohawk" Receiver manual) to make certain that it was correctly followed.

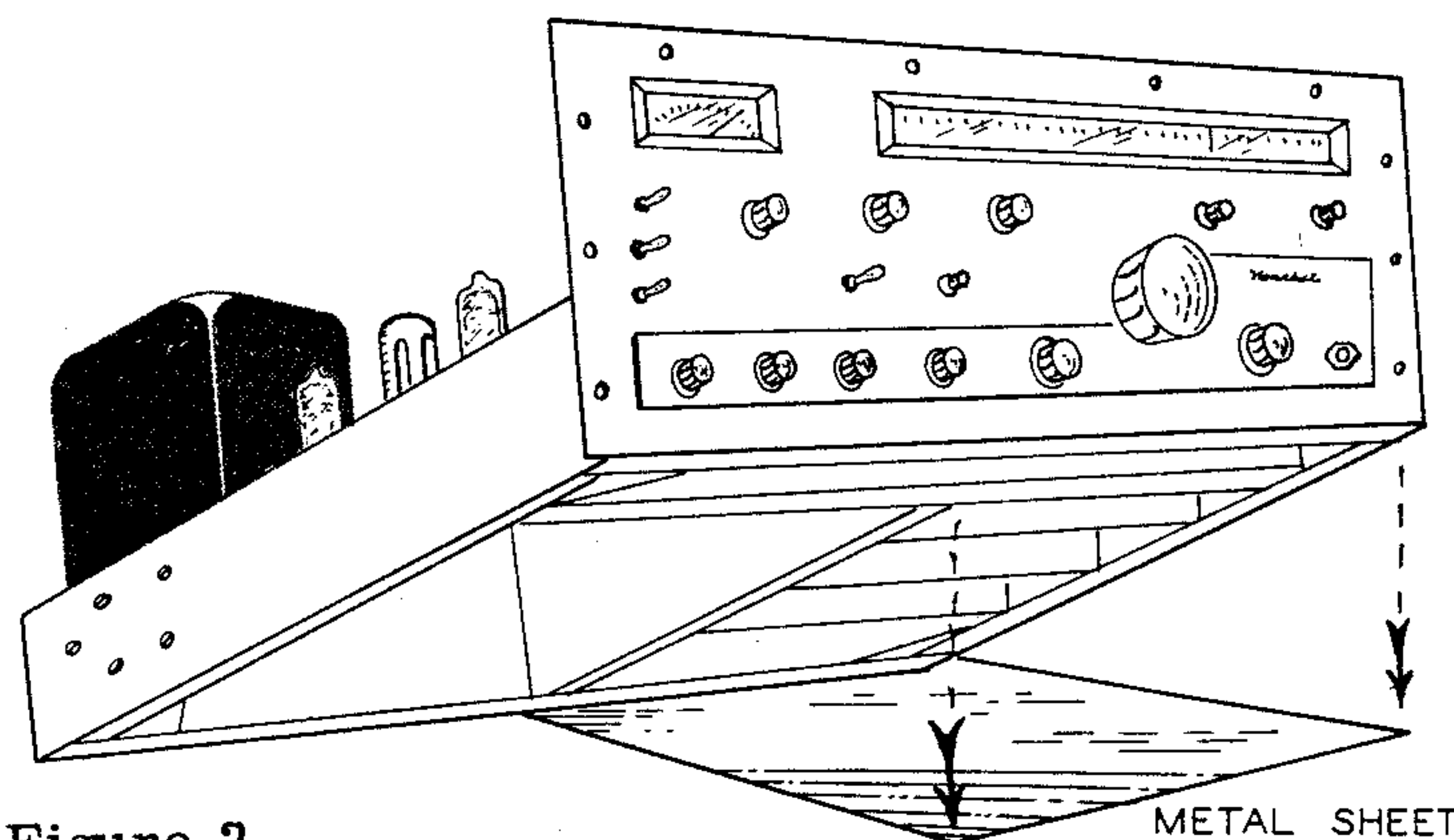

Figure 2

- () Turn the main tuning control, on the front of the receiver, until the dial pointer is to the extreme left hand side of the 80-meter band. Now rotate the 3/8" main tuning capacitor shaft until the plates of the capacitor are fully meshed. If the plates of this capacitor are incorrectly positioned, the calibration of the receiver will be incorrect.
- () All alignment must be done with LSB-USB switch in LSB position.

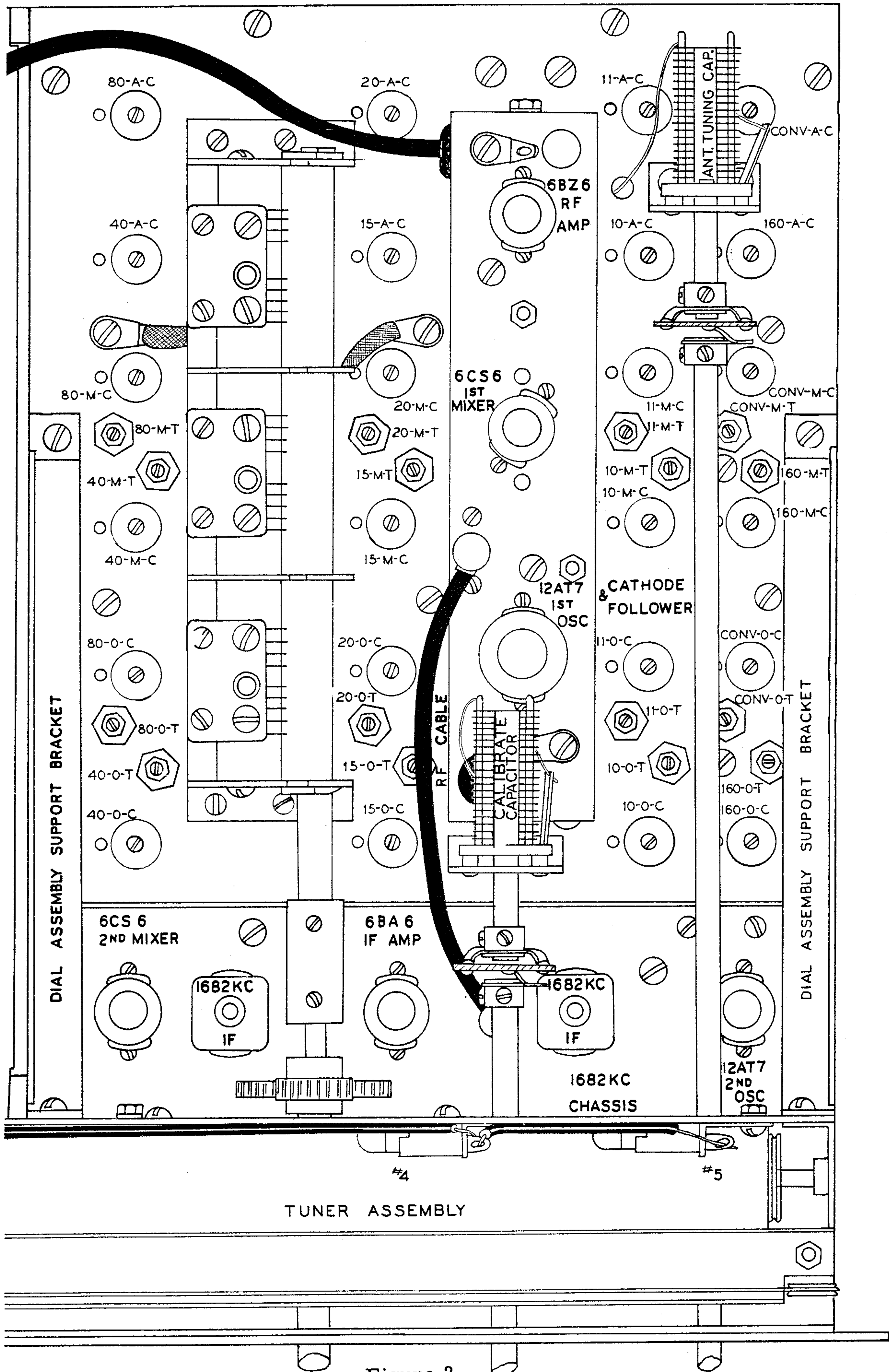

Figure 3

160-METER BAND, 1.8-2.0 MEGACYCLES

() Set the antenna tuning capacitor to one-half mesh. See Figures 3 and 4.

() Set the calibration capacitor to one-half mesh.

() Set the BFO at mid-position and the SSB-CW AM switch in SSB position.

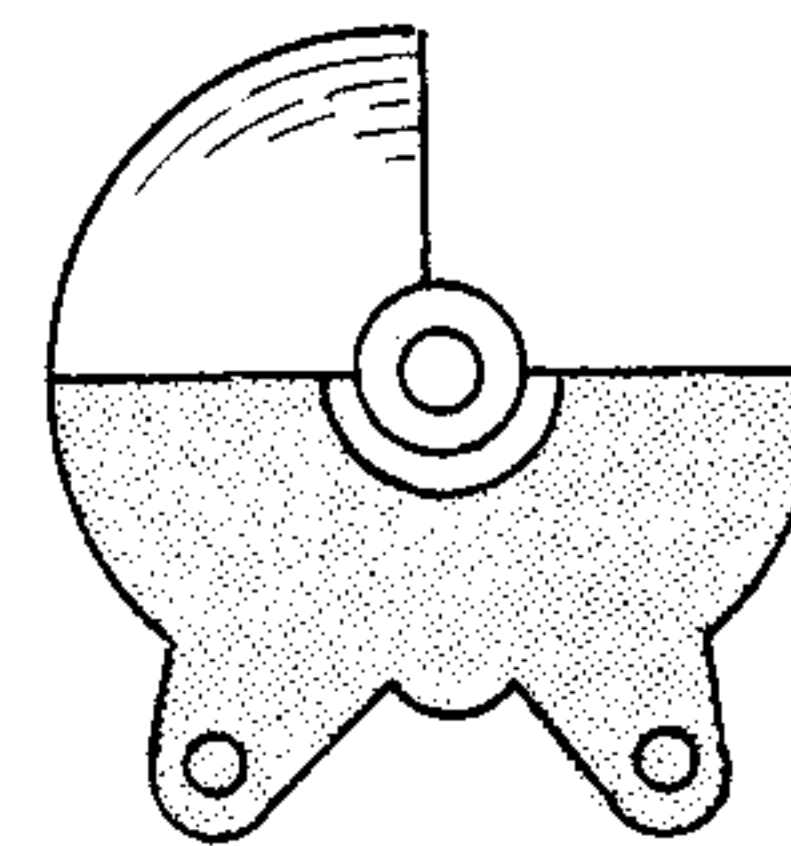

HALF MESH

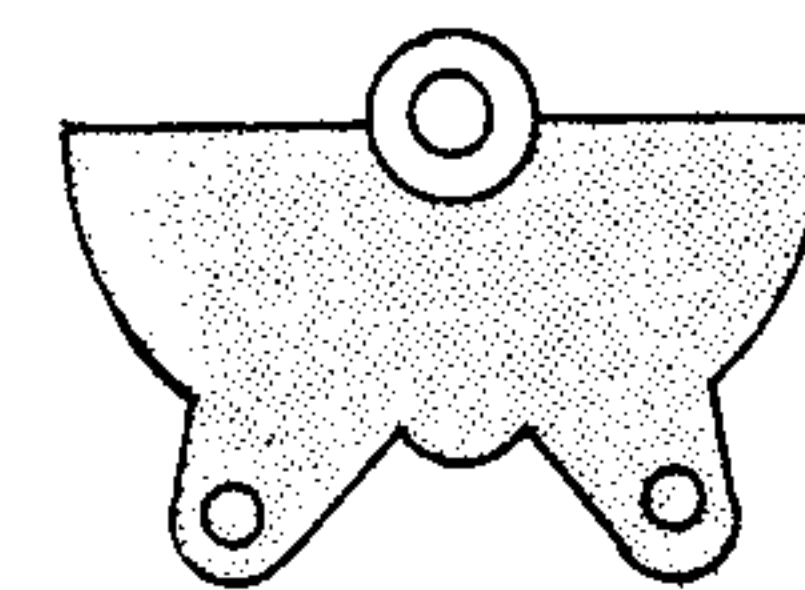

FULL MESH

Figure 4

() Rotate the main tuning knob clockwise to the high end of the band until the dial pointer coincides with the known frequency (2 megacycles is convenient). A slight amount of readjustment of the calibration capacitor (front panel control) may be required to align the signal to the correct dial reading.

() After setting the dial reading to the calibration signal, turn the main tuning control counterclockwise until the dial pointer is at 1800 kc.

() Using an input signal of 1800 kc, check whether the dial pointer corresponds to that frequency or if it is above or below it.

NOTE: If only one known frequency signal is available on each band, use the built-in 100 kc crystal oscillator and count up or down (as required to reach the desired frequency) from the known frequency.

For example: If a crystal oscillator having a known input frequency of 1900 kc is used for alignment, set the dial pointer to 1900 kc and zero beat by adjusting the calibrate capacitor (front panel control). The BFO should be set in its mid-position with the SSB-CW AM switch in SSB-CW position. After aligning the receiver to the external 1900 kc signal, turn off the alignment signal and depress the calibrate button. A beat note should now be heard from the built-in 100 kc crystal oscillator. While holding the calibrate button in, turn the main tuning knob clockwise. Every 100kc a beat note is evident. By counting up one beat note, the receiver is set at 2000 kc.

CAUTION: There may be RF signals feeding directly into the tuner assembly from external sources. Check to make certain that the receiver is tuned to the built-in 100 kc crystal oscillator by releasing the calibrate button. If the signal remains when the calibrate button is released, the unit is tuned to a signal from an external source and if aligned to this signal, a large calibration and logging deviation could occur.

() If the 1800 kc signal is above the 1800 mark on the dial, this shows the need for an increase in bandspread.

() If the 1800 kc signal is below the 1800 mark on the dial, this shows the need for a decrease in bandspread.

To increase the bandspread for the 160-meter oscillator section:

() Set the dial pointer, by turning the main tuning knob to 1800 kc.

() Turn the 160-meter oscillator coil slug (160-O-C) clockwise to zero beat with BFO.

() Tune the receiver to 2000 kc by turning the main tuning knob clockwise, until the dial pointer coincides with the 2000 kc dial marking.

() Inject the 2000 kc alignment signal and turn the 160-meter oscillator trimmer slug (160-O-T) counterclockwise until zero beat with BFO.

NOTE: The two preceding steps may have to be repeated several times to obtain correct bandspread. These adjustments are interacting and the signal should be zero beat at the low end with the coil slug, then zero beat at the high end with the trimmer, until the alignment signals are correctly set. CAUTION: Do not adjust the calibrate tuning control to obtain bandspread.

To decrease the bandspread for the 160-meter oscillator section:

- () Rotate the main tuning knob until the dial reads 1800 kc.
- () Inject the 1800 kc alignment signal and turn the 160-meter oscillator coil slug (160-O-C) counterclockwise until the signal is at zero beat with the BFO.
- () Tune the receiver to 2000 kc by turning the main tuning knob clockwise until the dial pointer coincides with the 2000 kc dial marking.
- () Inject the 2000 kc alignment signal and turn the 160-meter oscillator trimmer slug (160-O-T) clockwise until the signal is at zero beat with the BFO.

NOTE: The two preceding steps may have to be repeated several times to obtain correct bandspread. CAUTION: Do not adjust calibrate tuning capacitor (front panel control) to obtain bandspread.

- () If a counter is used for alignment, the actual output frequency of the oscillator section is 1682 kc above the dial frequency when accurately aligned.

For example: 1800 kc dial reading 3482 kc oscillator frequency
 2000 kc dial reading 3682 kc oscillator frequency

160-METER BAND - MIXER SECTION

- () With all controls set as in the preceding section, tune the receiver to the 1800 kc alignment signal.
- () Note the output level either on the S meter or on an audio output meter, as shown in Figure 1.
- () Tune the receiver to the 2000 kc alignment signal by turning the main tuning knob clockwise.
- () Check the output level, then compare it to the reading obtained at 1800 kc. If the output level is less than that read at 1800 kc, peak it by tuning the mixer trimmer capacitor (160-M-T).
- () Tune the receiver to 1800 kc and peak the output signal by tuning the mixer coil (160-M-C).

NOTE: It may be necessary to repeat these steps several times to obtain correct tracking.

CAUTION: It is mandatory that the 1800 kc and 2000 kc alignment signals be of the same magnitude in order to obtain correct tracking.

- () If the output level of 2000 kc is greater than the level of 1800 kc, reverse the two preceding steps and repeat until unit tracks properly.

160-METER BAND - RF SECTION

- () Set the antenna tuning capacitor at one-half mesh.
- () Tune the receiver to 1900 kc and depress the calibrate button.
- () Peak the antenna coil slug (160-A-C).

This completes the alignment of the 160-meter band.

80-METER BAND, 3.5-4 MEGACYCLES

- () Set the antenna tuning capacitor to one-half mesh. See Figures 3 and 4 on Pages 4 and 5.
- () Set the calibration capacitor to one-half mesh.
- () Set the BFO at mid-position and the SSB-CW AM switch in the SSB position.
- () Rotate the main tuning knob clockwise to the high end of the band until the dial pointer coincides with the known input frequency (4 megacycles is convenient). A slight amount of readjustment of the calibration capacitor (front panel control) may be required to align the signal to the correct dial reading.
- () After setting the dial reading to the calibration signal, turn the main tuning control counterclockwise until the dial pointer is at 3500 kc.
- () Using an input signal of 3500 kc, check whether the dial pointer corresponds to that frequency or if it is above or below it.

NOTE: If only one known frequency signal is available on each band, use the built-in 100 kc crystal oscillator and count up or down (as required to reach the desired frequency) from the known frequency.

For example: If a crystal oscillator is used for alignment, having a known input frequency of 3500 kc, set the dial pointer to 3500 kc and zero beat by adjusting the calibrate capacitor (front panel control). The BFO should be set in its mid-position with the SSB-CW AM switch in the SSB-CW position. After aligning the receiver to the external 3500 kc signal, turn off the alignment signal and depress the calibrate button. A beat note should now be heard from the built-in 100kc crystal oscillator. While holding the calibrate button in, turn the main tuning knob clockwise. Every 100 kc a beat note is evident. By counting up five beat notes, the receiver should be set at 4000 kc. It should be noted at this time, also, that the 100 kc crystal oscillator, if correctly set in the receiver, will have an extremely close accuracy as it was aligned to WWV. Any difference that should occur between the signal generator used and the 100 kc crystal calibrator, will undoubtedly be due to signal generator error.

CAUTION: There may be RF signals feeding directly into the tuner assembly from external sources. Check to make certain that the receiver is tuned to the built-in 100 kc crystal oscillator by releasing the calibrate button. If the signal remains when the calibrate button is released, the unit is tuned to a signal from an external source and, if aligned to this signal, a large calibration and logging deviation could occur. If the 3500 kc signal is above the 3500 mark on the dial, this shows the need for an increase in bandspread; if the 3500 kc signal is below the 3500 mark on the dial, this shows the need for a decrease in bandspread.

To increase the bandspread for the 80-meter oscillator section:

- () Set the dial pointer by turning the main tuning knob counterclockwise to 3500 kc.
- () Turn the 80-meter oscillator coil slug (80-O-C) clockwise to zero beat with BFO.
- () Tune the receiver to 4000 kc by turning the main tuning knob clockwise until the dial pointer coincides with the 4000 kc dial marking.
- () Inject the 4000 kc alignment signal and turn the 80-meter oscillator trimmer slug (80-O-T) counterclockwise until zero beat with BFO.

NOTE: The two preceding steps may have to be repeated several times to obtain correct bandspread. These adjustments are interacting and the signals should be zero beat at the low end with the coil slug, and zero beat at the high end with the trimmer, until the alignment signals are correctly set. CAUTION: Do not adjust the calibrate tuning control to obtain bandspread.

To decrease the bandspread for the 80-meter oscillator section:

- () Rotate the main tuning knob until the dial reads 3500 kc.
- () Inject the 3500 kc alignment signal and turn the 80-meter oscillator coil slug (80-O-C) counterclockwise until the signal is at zero beat with the BFO.
- () Tune the receiver to the 4000 kc by turning the main tuning knob clockwise until the dial pointer coincides with the 4000 kc dial marking.
- () Inject the 4000 kc alignment signal and turn the 80-meter oscillator trimmer slug (80-O-T) clockwise until the signal is at zero beat with the BFO.

NOTE: The two preceding steps may have to be repeated several times to obtain the correct bandspread. CAUTION: Do not adjust calibrate tuning capacitor (front panel control) to obtain bandspread.

- () If a counter is used for alignment, the actual output frequency of the oscillator section is 1682 kc above the dial frequency when accurately aligned.

For example: 3500 kc dial reading 5182 kc oscillator frequency
 4000 kc dial reading 5682 kc oscillator frequency

160-METER BAND - MIXER SECTION

- () With all controls set as in the preceding section, tune the receiver to the 3500 kc alignment signal.
- () Note the output level either on the S meter or on an audio output meter, as shown in Figure 1.
- () Tune the receiver to the 4000 kc alignment signal by turning the main tuning knob clockwise.
- () Check the output level, then compare it to the reading obtained at 3500 kc. If the output is less than that read at 3500 kc, peak it by tuning the mixer trimmer capacitor (80-M-T).
- () Tune the receiver to 3500 kc and peak the output signal by tuning the mixer coil (80-M-C).

NOTE: It may be necessary to repeat these steps several times to obtain correct tracking.

CAUTION: It is mandatory that the 3500 kc and 4000 kc alignment signals be of the same magnitude in order to obtain correct tracking.

- () If the output level at 4000 kc is greater than the level at 3500 kc, reverse the two preceding steps and repeat until the unit tracks properly.

80-METER BAND - RF SECTION

- () Set the antenna tuning capacitor at one-half mesh.
- () Tune the receiver to 3800 kc and depress the calibrate button.
- () Peak the antenna coil slug (80-A-C).

This completes the alignment of the 80-meter band.

40-METER BAND, 7000 KC-7300 KC

- () Set the antenna tuning capacitor to one-half mesh. See Figures 3 and 4.
- () Set the calibrate capacitor to one-half mesh.
- () Set the BFO at mid-position and the SSB-CW AM switch in SSB position.
- () Rotate the main tuning knob clockwise to the high end of the band until the dial pointer coincides with a known input frequency (7300 kc is convenient). A slight amount of readjustment of the calibrate capacitor (front panel control) may be required to align the signal to the correct dial reading.
- () After setting the dial reading to the calibration signal, turn the main tuning control counterclockwise until the dial pointer is at 7000 kc.
- () Using an input signal of 7000 kc, check whether the dial pointer corresponds to that frequency or if it is above or below it.

NOTE: If only one known frequency signal is available on each band, use the built-in 100 kc crystal oscillator and count up or down (as required to reach the desired frequency) from the known frequency.

For example: If a crystal oscillator having a known input frequency of 7000 kc is used for alignment, set the dial pointer to 7000 kc and zero beat by adjusting the calibrate capacitor (front panel control). The BFO should be set in its mid-position, with the SSB-CW AM switch in SSB-CW position. After aligning the receiver to the external 7000 kc signal, turn off the alignment signal and depress the calibrate button. A beat note should now be heard from the built-in 100 kc crystal oscillator. While holding the calibrate button in, turn the main tuning knob clockwise. Every 100 kc a beat note is evident. By counting up three beat notes, the receiver is set at 7300 kc.

CAUTION: There may be RF signals feeding directly into the tuner assembly from external sources. Check to make certain that the receiver is tuned to the built-in 100 kc crystal oscillator by releasing the calibrate button. If the signal remains when the calibrate button is released, the unit is tuned to a signal from an external source and, if aligned to this signal, a large calibration and logging deviation could occur.

- () If the 7000 kc signal is above the 7000 mark on the dial, this shows the need for an increase in bandspread.
- () If the 7000 kc signal is below the 7000 mark on the dial, this shows a need for a decrease in bandspread.

To increase the bandspread for the 40-meter oscillator section:

- () Set the dial pointer by turning the main tuning knob counterclockwise to 7000 kc.
- () Turn the 40-meter oscillator coil slug (40-O-C) clockwise to zero beat with BFO.
- () Tune the receiver to 7300 kc by turning the main tuning knob clockwise until the dial pointer coincides with the 7300 kc dial marking.
- () Inject the 7300 kc alignment signal and turn the 40-meter oscillator trimmer slug (40-O-T) counterclockwise until zero beat with BFO.

NOTE: The two preceding steps may have to be repeated several times to obtain correct bandspread. These adjustments are interacting and the signals should be zero beat at the low end with the coil slug, then zero beat at the high end with the trimmer, until the alignment signals are correctly set. CAUTION: Do not adjust the calibrate tuning control to obtain bandspread.

To decrease the bandspread for the 40-meter oscillator section:

- () Rotate the main tuning knob clockwise until the dial reads 7000 kc.
- () Inject the 7000 kc alignment signal and turn the 40-meter oscillator coil slug (40-O-C) counterclockwise until the signal is at zero beat with the BFO.
- () Tune the receiver to 7300 kc by turning the main tuning knob clockwise until the dial pointer coincides with the 7300 kc dial marking.
- () Inject the 7300 kc alignment signal and turn the 40-meter oscillator trimmer slug (40-O-T) clockwise until the signal is at zero beat with the BFO.

NOTE: The two preceding steps may have to be repeated several times to obtain correct bandspread. CAUTION: Do not adjust calibrate tuning capacitor (front panel control) to obtain bandspread.

- () If a counter is used for alignment, the actual output frequency of the oscillator section is 1682 kc above the dial frequency when accurately aligned.

For example: 7000 kc dial reading 8682 kc oscillator frequency
 7300 kc dial reading 8982 kc oscillator frequency

40-METER BAND - MIXER SECTION

- () With all controls set as in the preceding section, tune the receiver to the 7000 kc alignment signal.
- () Note the output level either on the S meter or on an audio output meter, as shown in Figure 1 on Page 3.
- () Tune the receiver to the 7300 kc alignment signal by turning the main tuning knob clockwise.
- () Check the output level, then compare it to the reading obtained at 7000 kc. If the output level is less than that read at 7000 kc, peak it by tuning the mixer trimmer capacitor (40-M-T).
- () Tune the receiver to 7000 kc and peak the output signal by tuning the mixer coil (40-M-C).

NOTE: It may be necessary to repeat these steps several times to obtain correct tracking.

CAUTION: It is mandatory that the 7000 kc and the 7300 kc alignment signals be of the same magnitude in order to obtain correct tracking.

- () If the output level of 7000 kc is greater than the level of 7300 kc, reverse the two preceding steps and repeat until the unit tracks properly.

40-METER BAND - RF SECTION

- () Set the antenna tuning capacitor at one-half mesh.
- () Tune the receiver to 7200 kc and depress the calibrate button.
- () Peak the antenna coil slug (40-A-C).

This completes the alignment of the 40-meter band.

20-METER BAND, 14,000 KC-14,350 KC

- () Set the antenna capacitor to one-half mesh. See Figures 3 and 4.
- () Set the calibrate capacitor to one-half mesh.

- () Set the BFO at mid-position and the SSB-CW AM switch in SSB position.
- () Rotate the main tuning knob clockwise to the high end of the band, until the dial pointer coincides with a known input frequency (14,300 kc would be convenient). A slight amount of readjustment of the calibration capacitor (front panel control) may be required to align the signal to the correct dial reading.

- () After setting the dial reading to the calibration signal, turn the main tuning control counterclockwise until the dial pointer is at 14,000 kc.

- () Using an input signal of 14,000 kc, check whether the dial pointer corresponds to that frequency or whether it is above or below it.

NOTE: If only one known frequency signal is available on each band, use the built-in 100 kc crystal oscillator and count up or down (as required to reach the desired frequency) from the known frequency. For example, see Page 3.

CAUTION: There may be RF signals feeding directly into the tuner assembly from external sources. Check to make certain that the receiver is tuned to the built-in 100 kc crystal oscillator by releasing the calibrate button. If the signal remains when the calibrate button is released, the unit is tuned to a signal from an external source, and if aligned to this signal, large calibration and logging deviation could occur.

- () If the 14,000 kc signal is above the 14,000 mark on the dial, this shows the need for an increase in bandspread.
- () If the 14,000 kc signal is below the 14,000 mark on the dial, this shows the need for a decrease in bandspread.

To increase the bandspread for the 20-meter oscillator section:

- () Set the dial pointer by turning the main tuning knob counterclockwise to 14,000 kc.
- () Turn the 20-meter oscillator coil slug (20-O-C) clockwise to zero beat with BFO.
- () Tune the receiver to 14,300 kc and turn the 20-meter oscillator trimmer slug (20-O-T) counterclockwise until zero beat with BFO.

NOTE: The two preceding steps may have to be repeated several times to obtain correct bandspread. These adjustments are interacting and the signal should be zero beat at the low end with the coil slug, and zero beat at the high end with the trimmer, until the alignment signals are correctly set. CAUTION: Do not adjust the calibrate tuning control to obtain bandspread.

To decrease the bandspread for the 20-meter oscillator section:

- () Rotate the main tuning knob clockwise until the dial reads 14,000 kc.
- () Inject the 14,000 kc alignment signal and turn the 20-meter oscillator coil slug (20-O-C) counterclockwise until the signal is at zero beat with the BFO.
- () Tune the receiver to 14,300 kc by turning the main tuning knob clockwise until the dial pointer coincides with the 14,300 dial marking.
- () Inject the 14,300 kc alignment signal and turn the 20-meter oscillator trimmer slug (20-O-T) clockwise until the signal is at zero beat with the BFO.

NOTE: The two preceding steps may have to be repeated several times to obtain correct bandspread. CAUTION: Do not adjust calibrate tuning capacitor (front panel control) to obtain bandspread.

- () If a counter is used for alignment, the actual output frequency of the oscillator section is 1682 kc above the dial frequency, when accurately aligned.

For example: 14,000 kc dial reading 15,682 kc oscillator frequency
 14,300 kc dial reading 15,982 kc oscillator frequency

20-METER BAND - MIXER SECTION

- () With all controls set as in the preceding section, tune the receiver to the 14,000 kc alignment signal.
- () Note the output level either on the S meter or on an audio output meter, as shown in Figure 1.
- () Tune the receiver to the 14,300 kc alignment signal by turning the main tuning knob clockwise. Check the output level, then compare it to the reading obtained at 14,000 kc. If the output level is less than that read at 14,000 kc, peak it by tuning the mixer trimmer capacitor (20-M-T).
- () Tune the receiver to 14,000 kc and peak the output signal by tuning the mixer coil (20-M-C).

NOTE: It may be necessary to repeat these steps several times to obtain correct tracking.

- () If the output level of 14,300 kc is greater than the level of 14,000 kc, reverse the two preceding steps and repeat until the unit tracks properly.

20-METER BAND - RF SECTION

- () Set the antenna tuning capacitor at one-half mesh.
- () Tune the receiver to 14,200 kc and depress the calibrate button.
- () Peak the antenna coil slug (20-A-C).

This completes the alignment of the 20-meter band.

15-METER BAND, 20,950 KC-21,500 KC

- () Set the antenna tuning capacitor to one-half mesh. See Figures 3 and 4.
- () Set the calibration capacitor to one-half mesh.
- () Set the BFO at mid-position and the SSB-CW AM switch in SSB-CW position.
- () Rotate the main tuning knob clockwise to the high end of the band until the dial pointer coincides with the known input frequency (21,500 kc is convenient). A slight amount of readjustment of the calibration capacitor (front panel control) may be required to align the signal to the correct dial reading.
- () After setting the dial reading to the calibration signal, turn the main tuning control counterclockwise until the dial pointer is at 21,000 kc.
- () Using an input signal of 21,000 kc, check whether the dial pointer corresponds to that frequency or if it is above or below it.

NOTE: If only one known frequency signal is available on each band, use the built-in 100 kc crystal oscillator and count up or down (as required to reach the desired frequency) from the known frequency. For example, see Page 3.

CAUTION: There may be RF signals feeding directly into the tuner assembly from external sources. Check to make certain that the receiver is tuned to the built-in 100 kc crystal oscillator by releasing the calibrate button. If the signal remains when the calibrate button is released, the unit is tuned to a signal from an external source and if aligned to this signal, large calibration and logging deviation could occur.

- () If the 21,000 kc signal is above the 21,000 mark on the dial, this shows the need for an increase in bandspread.
- () If the 21,000 kc signal is below the 21,000 mark on the dial, this shows the need for a decrease in bandspread.

To increase the bandspread for the 15-meter oscillator section:

- () Set the dial pointer by turning the main tuning knob counterclockwise to 21,000 kc.
- () Turn the 15-meter oscillator coil slug (15-O-C) clockwise to zero beat with BFO.
- () Tune the receiver to 21,500 kc by turning the main tuning knob clockwise until the dial pointer coincides with the 21,500 kc dial marking.
- () Inject the 21,500 kc alignment signal and turn the 15-meter oscillator trimmer slug (15-O-T) counterclockwise until zero beat with BFO.

NOTE: The two preceding steps may have to be repeated several times to obtain correct bandspread. The adjustments are interacting and the signal should be zero beat at the low end with the coil slug, then zero beat at the high end with the trimmer, until the alignment signals are correctly set. CAUTION: Do not adjust the calibrate tuning control to obtain bandspread.

To decrease the bandspread for the 15-meter oscillator section:

- () Rotate the main tuning knob counterclockwise until the dial reads 21,000 kc.
- () Inject the 21,000 kc alignment signal and turn the 15-meter oscillator coil slug (15-O-C) counterclockwise until the signal is at zero beat with the BFO.
- () Tune the receiver to 21,500 kc by turning the main tuning knob clockwise until the dial pointer coincides with the 21,500 dial marking.
- () Inject the 21,500 kc alignment signal and turn the 15-meter oscillator trimmer slug (15-O-T) clockwise until the signal is at zero beat with the BFO.

NOTE: The two preceding steps may have to be repeated several times to obtain correct bandspread. CAUTION: Do not adjust calibrate tuning capacitor (front panel control) to obtain bandspread.

- () If a counter is used for alignment, the actual output frequency of the oscillator section is 1682 kc above the dial frequency, when accurately aligned.

For example: 21,000 kc dial reading .. 22,682 kc oscillator frequency
 21,500 kc dial reading .. 23,182 kc oscillator frequency

15-METER BAND - MIXER SECTION

- () With all controls set as in the preceding section, tune the receiver to the 21,000 kc alignment signal.
- () Note the output level either on the S meter or on an audio output meter, as shown in Figure 1 on Page 3.
- () Tune the receiver to the 21,500 kc alignment by turning the main tuning knob clockwise.
- () Check the output level, then compare it to the reading obtained at 21,000 kc. If the output level is less than that read at 21,000 kc, peak it by tuning the mixer trimmer capacitor (15-M-T).
- () Tune the receiver to 21,000 and peak the output signal by tuning the mixer coil (15-M-C).

NOTE: It may be necessary to repeat these steps several times to obtain correct tracking.

CAUTION: It is mandatory that the 21,000 kc signal and the 21,500 kc alignment signals be of the same magnitude in order to obtain correct tracking.

- () If the output of 21,500 kc is greater than the level of 21,000 kc, reverse the two preceding steps and repeat until the unit tracks properly.

15-METER BAND - RF SECTION

- () Set the antenna tuning capacitor at one-half mesh.
- () Tune the receiver to 21,200 kc and depress the calibrate button.
- () Peak the antenna coil slug (15-A-C).

This completes the alignment of the 15-meter band.

11-METER BAND, 26.9 KC-27.3 KC (CITIZENS BAND)

- () Set the antenna tuning capacitor to one-half mesh. See Figures 3 and 4.
- () Set the calibrate capacitor to one-half mesh.
- () Set the BFO at mid-position and the SSB-CW AM switch in SSB-CW position.
- () Rotate the main tuning knob clockwise to the high end of the band until the dial pointer coincides with a known input frequency (27.3 megacycles is convenient). A slight amount of re-adjustment of the calibration capacitor (front panel control) may be required to align the signal to the correct dial reading.
- () After setting the dial reading to the calibration signal, turn the main tuning control counter-clockwise until the dial pointer is at 27.0 megacycles.
- () Using an input signal of 27.0 megacycles, check whether the dial pointer corresponds to that frequency or if it is above or below it.

NOTE: If only one known frequency signal is available on each band, use the built-in 100 kc crystal oscillator and count up or down (as required to reach the desired frequency) from the known frequency. For example, see Page 3.

CAUTION: There may be RF signals feeding directly into the tuner assembly from external sources. Check to make certain that the receiver is tuned to the built-in 100 kc crystal oscillator by releasing the calibrate button. If the signal remains when the calibrate button is released, the unit is tuned to a signal from an external source and if aligned to this signal, a large calibration and logging deviation could occur.

- () If the 27.0 megacycle signal is above the 27.0 mark on the dial, this shows the need for an increase in bandspread.
- () If the 27.0 megacycle signal is below the 27.0 mark on the dial, this shows the need for a decrease in bandspread.

To increase the bandspread for the 11-meter oscillator section:

- () Set the dial pointer by turning the main tuning knob counterclockwise to 27.0 megacycles.
- () Turn the 11-meter oscillator coil slug (11-O-C) clockwise to zero beat with BFO.
- () Tune the receiver to 27.3 by turning the main tuning knob clockwise until the dial pointer coincides with the 27.3 dial marking.
- () Inject the 27.3 megacycle alignment signal and turn the 11-meter oscillator trimmer slug (11-O-T) counterclockwise until zero beat with BFO.

NOTE: The two preceding steps may have to be repeated several times to obtain correct bandspread. These adjustments are interacting and the signals should be zero beat at the low end with the coil slug, then zero beat at the high end with the trimmer, until the alignment signals are correctly set. CAUTION: Do not adjust the calibrate tuning control to obtain bandspread.

To decrease the bandspread for the 11-meter oscillator section:

- () Rotate the main tuning knob counterclockwise until the dial reads 27 megacycles.
- () Inject the 27 megacycle alignment signal and turn the 11-meter oscillator coil slug (11-O-C) counterclockwise until the signal is at zero beat with the BFO.
- () Tune the receiver to 27.3 megacycle by turning the main tuning knob clockwise until the dial pointer coincides with the 27.3 dial marking.
- () Inject the 27.3 megacycle alignment signal and turn the 11-meter oscillator trimmer slug (11-O-T) clockwise until zero beat with BFO.

NOTE: The two preceding steps may have to be repeated several times to obtain correct bandspread. CAUTION: Do not adjust calibrate tuning capacitor (front panel control) to obtain bandspread.

- () If a counter is used for alignment, the actual output frequency of the oscillator section is 1682 kc above the dial frequency, when accurately aligned.

For example: 27.0 mc dial reading 28.682 mc oscillator frequency
 27.3 mc dial reading 28.982 mc oscillator frequency

11-METER BAND - MIXER SECTION

- () With all controls set as in preceding section, tune the receiver to the 27.0 megacycles alignment signal.
- () Note the output level either on the S meter or on an audio output meter, as shown in Figure 1.
- () Tune the receiver to the 27.3 megacycle alignment signal by turning the main tuning knob clockwise.
- () Check the output level, then compare it to the reading obtained at 27 megacycles. If the output level is less than that read at 27 megacycles, peak it by tuning the mixer trimmer capacitor (11-M-T).
- () Tune the receiver to the 27.0 megacycle and peak the output signal by tuning the mixer coil (11-M-C).

NOTE: It may be necessary to repeat these steps several times to obtain correct tracking.

CAUTION: It is mandatory that the 27 megacycle and the 27.3 megacycle alignment signals be of the same magnitude in order to obtain correct tracking.

- () If the output level of the 27.3 megacycle signal is greater than the level of the 27 megacycle signal, reverse the two preceding steps and repeat until the unit tracks properly.

11-METER BAND - RF SECTION

- () Set the antenna tuning capacitor at one-half mesh.
- () Tune the receiver to 27.1 megacycles and depress the calibrate button.
- () Peak the antenna coil slug (11-A-C).

This completes the alignment of the 11-meter band.

10-METER BAND, 28-29.7 MEGACYCLES

- () Set the antenna tuning capacitor to one-half mesh. See Figures 3 and 4.
- () Set the calibration capacitor to one-half mesh.
- () Set the BFO at mid-position and the SSB-CW AM in SSB-CW position.
- () Rotate the main tuning knob clockwise to the high end of the band until the dial pointer coincides with a known input frequency (29.7 megacycles is convenient). A slight amount of readjustment of the calibration capacitor (front panel control) may be required to align the signal to the correct dial reading.
- () After setting the dial reading to the calibration signal, turn the main tuning control clockwise until the dial pointer is at 28 megacycles.
- () Using an input signal of 28 megacycles, check whether the dial pointer corresponds to that frequency or if it is above or below it.

NOTE: If only one known frequency signal is available on each band, use the built-in 100 kc crystal oscillator and count up or down (as required to reach the desired frequency) from the known frequency. For example, see Page 3.

CAUTION: There may be RF signals feeding directly into the tuner assembly from external sources. If using the 100 kc crystal calibrator, check to make certain that the receiver is tuned to the built-in 100 kc crystal oscillator by releasing the calibrate button. If the signal remains when the calibrate button is released, the unit is tuned to a signal from an external source and if aligned to this signal, a large calibration and logging deviation could occur.

- () If the 28 megacycle signal is above the 28 megacycle mark on the dial, this shows a need for an increase in bandspread.
- () If the 28 megacycle signal is below the 28 megacycle mark on the dial, this shows the need for a decrease in bandspread.

To increase the bandspread for the 10-meter oscillator section:

- () Set the dial pointer by turning the main tuning knob counterclockwise to 28.0 megacycles.
- () Turn the 10-meter oscillator coil slug (10-O-C) clockwise to zero beat with BFO.
- () Tune the receiver to 29.7 megacycles by turning the main tuning knob clockwise until the dial pointer coincides with the 29.7 dial marking.
- () Inject the 29.7 alignment signal and turn the 10-meter oscillator trimmer slug (10-O-T) clockwise until zero beat with the BFO.

NOTE: The two preceding steps may have to be repeated several times to obtain correct bandspread. These adjustments are interacting and the signals should be zero beat at the low end with the coil slug, then zero beat at the high end with the trimmer, until the alignment signals are correctly set. CAUTION: Do not adjust the calibrate tuning control to obtain bandspread.

To decrease the bandspread for the 10-meter oscillator section:

- () Rotate the main tuning knob counterclockwise until the dial reads 28.0 megacycles.
- () Inject the 28 megacycle alignment signal and turn the 10-meter oscillator coil slug (10-O-C) counterclockwise until the signal is at zero beat with the BFO.
- () Tune the receiver to 29.7 megacycle by turning the main tuning knob clockwise until the dial pointer coincides with the 29.7 dial marking.
- () Inject the 29.7 megacycle alignment signal, then turn the 10-meter oscillator trimmer slug (10-O-T) clockwise until the signal is at zero beat with the BFO.

NOTE: The two preceding steps may have to be repeated several times to obtain correct bandspread. CAUTION: Do not adjust calibrate tuning capacitor (front panel control) to obtain bandspread.

- () If a counter is used for alignment, the actual output frequency of the oscillator is 1682 kc above the dial frequency, when accurately aligned.

For example:	29.0 mc dial reading	29,682 kc oscillator frequency
	29.7 mc dial reading	31,382 kc oscillator frequency

10-METER BAND - MIXER SECTION

- () With all controls set as in preceding section, tune the receiver to the 28,000 kc alignment signal.
- () Note the output level either on the S meter or on an audio output meter, as shown in Figure 1.
- () Tune the receiver to the 29.7 megacycle alignment signal by turning the main tuning knob clockwise.
- () Check the output level, then compare it to the reading obtained at 28.0 megacycles. If the output level is less than that read at 28.0 megacycles, peak it by tuning the mixer trimmer capacitor (10-M-T).
- () Tune the receiver to 29.7 megacycles and peak the output signal by tuning the mixer coil (10-M-C).

NOTE: It may be necessary to repeat these steps several times to obtain correct tracking.

CAUTION: It is mandatory that the 28 megacycles signal and the 29.7 megacycle alignment signal be of the same magnitude in order to obtain correct tracking.

- () If the output level of 29.7 megacycles is greater than the level of 28.0 megacycles, reverse the two preceding steps and repeat until unit tracks properly.

10-METER BAND - RF SECTION

- () Set the antenna tuning capacitor at one-half mesh.
- () Tune the receiver to 29 megacycles and depress the calibrate button.
- () Peak the antenna coil slug (10-A-C).

This completes the alignment of the 10-meter band.

CONVERTER BAND, 22-26 MEGACYCLES

NOTE: Before proceeding with the alignment of the converter band, it will be necessary to correlate the dial markings to the actual frequency.

The 50 and 144 dial marking actual frequency is 22 megacycles;
51-145 dial marking - actual frequency 23 megacycles;
52-146 dial marking - actual frequency 24 megacycles;
53-147 dial marking - actual frequency 25 megacycles;
54-148 dial marking - actual frequency 26 megacycles.

- () Set the antenna tuning capacitor to three-quarter mesh. See Figures 3 and 4.
- () Set the calibration capacitor to one-half mesh.
- () Set the BFO at mid-position and the SSB-CW AM switch in SSB position.
- () Rotate the main tuning knob clockwise to the high end of the band until the dial pointer coincides with a known input frequency (26 megacycles is convenient). The dial reading will read 54 megacycles. A slight amount of readjustment of the calibration capacitor (front panel control) may be required to align the 26 megacycle signal to the 54 megacycle dial reading.

- () After setting the dial reading to the calibration signal, turn the main tuning control counterclockwise until the dial pointer is at 50-144 megacycles.
- () Using an input signal of 22 megacycles, check whether the dial pointer corresponds to that frequency or if it is above or below it.

NOTE: If only one known frequency signal is available on each band, use the built-in 100 kc crystal oscillator and count up or down (as required to reach the desired frequency) from the known frequency. For example, see Page 3.

CAUTION: There may be RF signals feeding directly into the tuner assembly from external sources. Check to make certain that the receiver is tuned to the built-in 100 kc crystal oscillator by releasing the calibrate button. If the signal remains when the calibrate button is released, the unit is tuned to a signal from an external source and if aligned to this signal, a large calibration and logging deviation could occur.

- () If the 22 megacycle signal is above the 50 megacycles mark on the dial, this shows the need for an increase in bandspread.
- () If the 22 megacycle signal is below the 50 mark on the dial, this shows the need for a decrease in bandspread.

To increase the bandspread for the converter oscillator section:

- () Set the dial pointer by turning the main tuning knob counterclockwise to 50 megacycles.
- () Turn the converter oscillator coil slug (Conv. -O-C) clockwise to zero beat with BFO.
- () Tune the receiver to 54 megacycles by turning the main tuning knob clockwise until the dial pointer coincides with the 54 megacycle dial marking.
- () Inject the 26 megacycle alignment signal and turn the converter oscillator trimmer slug (Conv. -O-T) counterclockwise until at zero beat with BFO.

NOTE: The two preceding steps may have to be repeated several times to obtain correct bandspread. These adjustments are interacting and the signals should be zero beat at the low end with the coil slug, then zero beat at the high end with the trimmer, until the alignment signals are correctly set. CAUTION: Do not adjust the calibrate tuning control to obtain bandspread.

To decrease the bandspread for the converter oscillator section:

- () Rotate the main tuning knob counterclockwise until the dial reads 50 megacycles.
- () Inject the 22 megacycle alignment signal and turn the converter oscillator coil slug (Conv. -O-C) counterclockwise until the signal is at zero beat with the BFO.
- () Tune the receiver to 54 megacycles by turning the main tuning knob clockwise until the dial pointer coincides with the 54 dial marking.
- () Inject the 26 megacycle alignment signal and turn the converter oscillator trimmer slug (Conv. -O-T) clockwise until the signal is at zero beat with the BFO.

NOTE: The two preceding steps may have to be repeated several times to obtain correct bandspread. CAUTION: Do not adjust the calibrate tuning capacitor (front panel control) to obtain bandspread.

- () If a counter is used for alignment, the actual output frequency of the oscillator is 1682 kc above the dial frequency when accurately aligned. For example, when the dial pointer indicates 50 megacycles, the oscillator frequency is at 23.682 megacycles; when the dial reading indicates 54 megacycles, the oscillator frequency is at 27.682 megacycles.

CONVERTER BAND - MIXER SECTION

- () With all controls set as in the preceding section, tune the receiver to the 50 megacycle alignment reading, actual input signal 22 megacycles.
- () Note the output level either on the S meter or on an audio output meter, as shown in Figure 1.
- () Tune the receiver to the 54 megacycle dial reading, or the 26 megacycles alignment signal, by turning the main tuning knob clockwise.
- () Check the output level, then compare it to the reading obtained at 22 megacycles. If the output level is less than that read at 22 megacycles, peak it by tuning the mixer trimmer capacitor (Conv. -M-T).
- () Tune the receiver to the 22 megacycle signal and peak the output signal by tuning the mixer coil (Conv. -M-C).

NOTE: It may be necessary to repeat these steps several times to obtain correct tracking.

CAUTION: It is mandatory that both alignment signals be of the same magnitude in order to obtain correct tracking.

- () If the output level of 26 megacycles is greater than the level at 22 megacycles, reverse the two preceding steps and repeat until unit tracks properly.

CONVERTER BAND - RF SECTION

- () Set the antenna tuning capacitor at three-quarter mesh.
- () Tune the receiver to 24 megacycles and depress the calibrate button.
- () Peak the antenna coil slug (Conv. -A-C).

This completes the alignment of the converter band.

SERVICE

If, after applying the information contained in this manual and your best efforts on the unit, you are still unable to obtain proper performance from the instrument, it is suggested that you take advantage of the technical facilities which the Heath Company makes available to its customers.

The Technical Consultation Department is maintained for the purpose of providing Heath customers with a personalized technical consultation service; this service is available to you without charge. The technical consultants are thoroughly familiar with all details of the instrument and can usually localize the trouble from a suitable description of the difficulty encountered. It is, of course, necessary that you provide full and complete information concerning your problem when writing to the Technical Consultation Department for assistance. For instance, clearly identify the kit involved, giving the purchase date and, if possible, the invoice number; describe in detail the difficulty that you have encountered; state what you have attempted to do to rectify the trouble, what results have been achieved, and include any information or clues that you feel could possibly be of value to the consultant who handles your problem. Failure to provide complete descriptive details may lead to incorrect assumptions on the part of the consultant and needless delay in the solution to your problem. Quite frequently, when the information given the consultants is complete, concise and reliable, a diagnosis of the difficulty can be made with confidence and specific instructions given for its correction. If replacement of a component is involved in the correction, the component will be shipped to you, subject to the terms and conditions of the Warranty.

The Factory Service facilities are also available to you, in case you are not familiar enough with electronics to provide our consultants with sufficient information on which to base a diagnosis of your difficulty, or in the event that you prefer to have the difficulty corrected in this manner. You may return the completed instrument to the Heath Company for inspection and necessary repairs and adjustments. You will be charged a minimal fee plus the price of any additional parts or material required. However, if the instrument is returned within the Warranty period, parts charges will be governed by the terms of the Warranty. State the date of purchase and give invoice number, if possible.

Local Service by Authorized Heathkit Service Centers is also available and often will be your fastest, most efficient method of obtaining service for your Heathkits. Although you may find charges for local service somewhat higher than for factory service, the amount of increase is usually offset by the transportation charges you will pay if you elect to return your kit to the Heath Company.

Heathkit Service Centers will honor the regular 90 day Heathkit Parts Warranty on all kits, whether purchased through a dealer or directly from Heath Company. It will be necessary that you verify the purchase date of your kit by presenting your copy of the Heath Company invoice to the authorized Service Center involved.

Under the conditions specified in the Warranty, replacement parts are supplied without charge; however, if your local Service Center assists you in locating a defective part (or parts) in your Heathkit, or installs a replacement part for you, he may charge you for this service.

Heathkits purchased locally and returned to Heath Company for service must be accompanied by your copy of the dated sales receipt from your authorized Heathkit dealer in order to be eligible for parts replacement under the terms of the Warranty.

THESE SERVICE POLICIES APPLY ONLY TO COMPLETED INSTRUMENTS CONSTRUCTED IN ACCORDANCE WITH THE INSTRUCTIONS AS STATED IN THE MANUAL. Instruments that are not entirely completed or instruments that are modified in design will not be accepted for repair. Instruments showing evidence of acid core solder or paste fluxes will be returned NOT repaired.

For information regarding modifications of Heathkits for special applications, it is suggested that you refer to any one or more of the many publications that are available on all phases of electronics. They can be obtained at or through your local library, as well as at most electronic outlet stores. Although the Heath Company welcomes all comments and suggestions, it would be impossible to design, test, evaluate and assume responsibility for proposed circuit changes for specific purposes. Therefore, such modifications must be made at the discretion of the kit builder, according to information which will be much more readily available from some local source.

REPLACEMENTS

Material supplied with Heathkits has been carefully selected to meet design requirements and ordinarily will fulfill its function without difficulty. Occasionally improper instrument operation can be traced to a faulty tube or component. Should inspection reveal the necessity for replacement, write to the Heath Company and supply all of the following information:

- A. Thoroughly identify the part in question by using the part number and description found in the manual Parts List. When ordering replacement coils, the padder capacitor on each coil is an integral part of the coil and is included in the part number. The padder supplied on the replacement coil may differ slightly in value from the one on the defective coil. However, this is normal and is necessary to compensate for slight coil variation.

- B. Identify the type and model number of kit in which it is used.
- C. Mention the order number and date of purchase.
- D. Describe the nature of defect or reason for requesting replacement.

The Heath Company will promptly supply the necessary replacement. Please do not return the original component until specifically requested to do so. Do not dismantle the component in question as this will void the guarantee. If tubes are to be returned, pack them carefully to prevent breakage in shipment as broken tubes are not eligible for replacement. This replacement policy does not cover the free replacement of parts that may have been broken or damaged through carelessness on the part of the kit builder.

SHIPPING INSTRUCTIONS

In the event that your Instrument must be returned for service, these instructions should be carefully followed.

ATTACH A TAG TO THE INSTRUMENT BEARING YOUR NAME, COMPLETE ADDRESS, INVOICE NUMBER ON WHICH THE INSTRUMENT WAS PURCHASED, AND A BRIEF DESCRIPTION OF THE DIFFICULTY ENCOUNTERED. Wrap the Instrument in heavy paper, exercising care to prevent damage. Place the wrapped Instrument in a stout carton of such size that at least three inches of shredded paper, excelsior, or other resilient packing material can be placed between all sides of the Instrument and the carton. Close and seal the carton with gummed paper tape, or alternately, tie securely with stout cord. Clearly print the address on the carton as follows:

To: HEATH COMPANY
Benton Harbor, Mich.

Include your name and return address on the outside of the carton. Preferably affix one or more "Fragile" or "Handle With Care" labels to the carton, or otherwise so mark with a crayon of bright color. Ship by parcel post or prepaid express; note that a carrier cannot be held responsible for damage in transit, if in HIS OPINION, the article is inadequately packed for shipment. Your Instrument will be returned by express collect.

SPECIFICATION CHANGES

All prices are subject to change without notice. The Heath Company reserves the right to discontinue instruments and to change specifications at any time without incurring any obligation to incorporate new features in instruments previously sold.

WARRANTY

Heath Company warrants that for a period of three months from the date of shipment, all Heathkit parts shall be free of defects in materials and workmanship under normal use and service and that in fulfillment of any breach of such warranty, Heath Company shall replace such defective parts upon the return of the same to its factory. The foregoing warranty shall apply only to the original buyer, and is and shall be in lieu of all other warranties, whether express or implied and of all other obligations or liabilities on the part of Heath Company and in no event shall Heath Company be liable for any anticipated profits, consequential damages, loss of time or other losses incurred by the buyer in connection with the purchase, assembly or operation of Heathkits or components thereof. No replacement shall be made of parts damaged by the buyer in the course of handling or assembling Heathkit equipment.

NOTE: The foregoing warranty is completely void and we will not replace, repair or service instruments or parts thereof in which acid core solder or paste fluxes have been used.

HEATH COMPANY

PARTS LIST

PART No.	PARTS Per Kit	DESCRIPTION	PART No.	PARTS Per Kit	DESCRIPTION
Resistors			Sockets-Terminal Strips		
1-6	1	470 Ω 1/2 watt $\pm 10\%$	431-5	1	5-lug terminal strip
1-9	2	1 K Ω 1/2 watt $\pm 10\%$	431-12	1	4-lug terminal strip
1-20	2	10 K Ω 1/2 watt $\pm 10\%$	432-6	1	6-connector plug
1-22	1	22 K Ω 1/2 watt $\pm 10\%$	434-35	2	7-pin miniature socket
1-26	1	100 K Ω 1/2 watt $\pm 10\%$	434-36	1	9-pin noval socket
1-29	1	220 K Ω 1/2 watt $\pm 10\%$	434-42	1	Phono socket
1-33	1	470 K Ω 1/2 watt $\pm 10\%$			
1-35	1	1 megohm 1/2 watt $\pm 10\%$	Hardware		
1-41	1	10 Ω 1/2 watt $\pm 10\%$	250-8	19	#6 sheet metal screw
1-45	3	220 Ω 1/2 watt $\pm 10\%$	250-137	4	#8-32 x 3/8" BHMS
1A-7	2	47 K Ω 1 watt $\pm 10\%$	250-160	4	#4-36 x 1/4" BHMS
			250-161	2	#5-40 x 1 1/2" BHMS
Capacitors			250-162	1	#6-32 x 1/2" BHMS
20-63	1	47 $\mu\mu\text{f}$ $\pm 10\%$ mica	252-3	2	#6-32 x 1/4" hex nut
20-113	2	470 $\mu\mu\text{f}$ $\pm 10\%$ mica	252-33	2	5-40 x 5/16" hex nut
B21-16	10	.01 $\mu\mu\text{f}$ GMV disc Z5U	253-48	4	.171 ID x .375 OD flat washer
26-60	2	27 $\mu\mu\text{f}$ air trimmer	254-1	8	#6 internal lockwasher
26-61	1	3-gang 6 section tuning	254-6	6	#6 external lockwasher
31-22	8	1-12 $\mu\mu\text{f}$ trimmer, ceramic	254-9	4	#4 internal lockwasher
31-32	8	1-12 $\mu\mu\text{f}$ trimmer, glass	259-1	14	#6 solder lug
Coils			451-1	16	#6-32 spade bolt
(See Item A under Replacements on Page 21 before ordering replacement coils)					
Coils (Oscillator Section)			Switch		
40-244	1	160-meter oscillator	63-224	1	Band switch
40-245	1	80-meter oscillator			
40-246	1	40-meter oscillator	Tubes		
40-247	1	20-meter oscillator	411-24	1	12AT7 Oscillator-Cathode follower
40-248	1	15-meter oscillator	411-26	1	6BZ6 RF amp
40-249	1	11-meter oscillator	411-105	1	6CS6 Mixer
40-250	1	10-meter oscillator			
40-251	1	Converter oscillator	Sheet Metal Parts		
Coils (Mixer Section)			200-M167	1	RF chassis plate
40-252	1	160-meter mixer	200-M170	1	RF subchassis
40-253	1	80-meter mixer	204-M166	1	Front condenser mounting bracket
40-254	1	40-meter mixer	204-M167	1	Rear condenser mounting bracket
40-255	1	20-meter mixer	205-M85	1	RF subchassis plate
40-256	1	15-meter mixer	206-M67	2	Shield plate
40-257	1	11-meter mixer			
40-258	1	10-meter mixer	Miscellaneous		
40-259	1	Converter mixer	73-1	2	3/8" rubber grommet
Coils (Antenna Section)			206-3	1	9-pin tube shield
40-260	1	160-meter antenna	206-25	2	7-pin tube shield
40-261	1	80-meter antenna	207-5	1	Cable clamp
40-262	1	40-meter antenna	255-36	2	#6 x 1" spacer
40-263	1	20-meter antenna			
40-264	1	15-meter antenna			
40-265	1	11-meter antenna			
40-266	1	10-meter antenna			
40-267	1	Converter antenna			

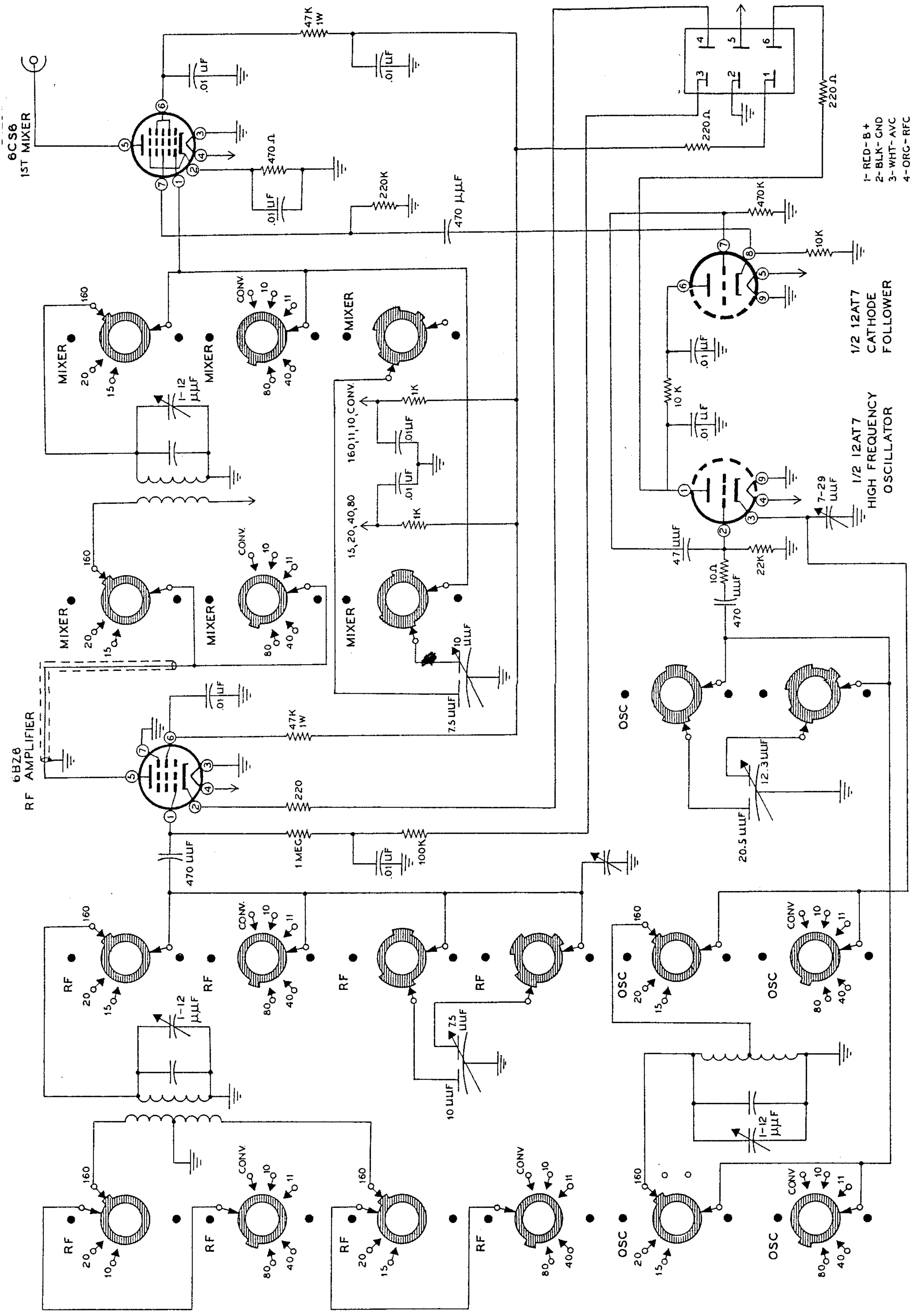

100-139 TUNER ASSEMBLY
MODEL RX 1