

ASSEMBLING
AND USING
YOUR.....

Heathkit

VACUUM TUBE
VOLTMETER
MODEL V-6

595-40

HEATH COMPANY

BENTON HARBOR,
MICHIGAN

PRICE \$1.00

THE WORLD'S *Finest* TEST EQUIPMENT IN KIT FORM

STANDARD COLOR CODE — RESISTORS AND CAPACITORS

AXIAL LEAD RESISTOR	INSULATED UNINSULATED Color	FIRST RING BODY COLOR First Figure	SECOND RING END COLOR Second Figure	THIRD RING DOT COLOR Multiplier	DISC CERAMIC RMA CODE
	BLACK BROWN RED ORANGE YELLOW GREEN BLUE VIOLET GRAY WHITE	0 1 2 3 4 5 6 7 8 9	0 1 2 3 4 5 6 7 8 9	None 0 00 ,000 0,000 00,000 000,000 0,000,000 00,000,000 000,000,000	
RADIAL LEAD DOT RESISTOR 	5-DOT RADIAL LEAD CERAMIC CAPACITOR 			EXTENDED RANGE TC CERAMIC HI-CAP 	
RADIAL LEAD (BAND) RESISTOR 	BY-PASS COUPLING CERAMIC CAPACITOR 			AXIAL LEAD CERAMIC CAPACITOR 	

The standard color code provides all necessary information required to properly identify color coded resistors and capacitors. Refer to the color code for numerical values and the zeroes or multipliers assigned to the color's used. A fourth color band on resistors determines tolerance rating as follows: Gold = 5%, silver = 10%. Absence of the fourth band indicates a 20% tolerance rating.

The physical size of carbon resistors is determined by their wattage rating. Carbon resistors most commonly used in Heathkits are 1/2 watt. Higher wattage rated resistors when specified are progressively larger in physical size. Small wire wound resistors 1/2 watt, 1 or 2 watt may be color coded but the first band will be double width.

MOLDED MICA TYPE CAPACITORS

CURRENT STANDARD CODE 	RMA 3-DOT (OBSOLETE) RATED 500 W.V.D.C. ± 20% TOL. 	BUTTON SILVER MICA CAPACITOR
RMA (5-DOT OBSOLETE CODE) 	RMA 6-DOT (OBSOLETE) 	RMA 4-DOT (OBSOLETE)

MOLDED PAPER TYPE CAPACITORS

TUBULAR CAPACITOR 	MOLDED FLAT CAPACITOR Commercial Code 	JAN. CODE CAPACITOR
------------------------------	---	--------------------------------

The tolerance rating of capacitors is determined by the color code. For example: red = 2%, green = 5%, etc. The voltage rating of capacitors is obtained by multiplying the color value by 100. For example: orange = 3 × 100 or 300 volts. Blue = 6 × 100 or 600 volts.

In the design of Heathkits, the temperature coefficient of ceramic or mica capacitors is not generally a critical factor and therefore Heathkit manuals avoid reference to temperature coefficient specifications.

HEATHKIT VTVM MODEL V-6

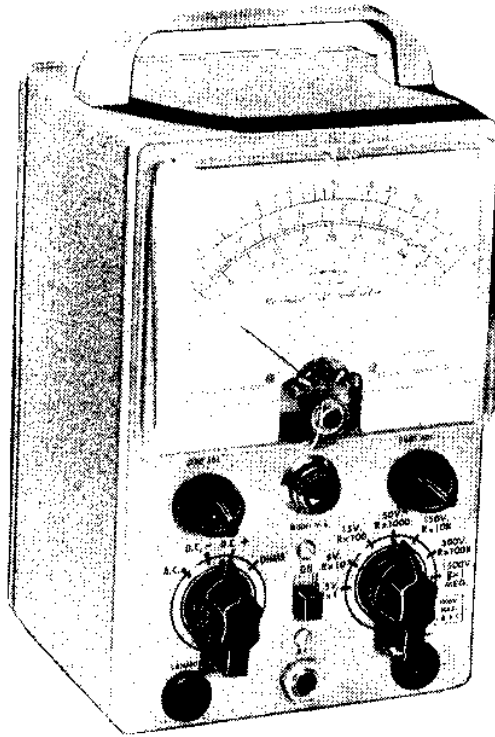

SPECIFICATIONS

Power Requirements:	105-125V 50/60 Cycle AC, 10 Watts.
Cabinet Size:	7 3/8" high x 4 11/16" wide x 4 1/8" deep.
Kit Shipping Weight:	7 pounds
Meter:	4 1/2" Streamlined case with 200 microampere movement.
Multipliers:	Precision type.
Tubes:	1 - 12AU7 Twin triode meter bridge. 1 - 6H6 Twin diode AC rectifier.
Power Supply:	Power transformer and selenium rectifier.
Battery	1 1/2 Volt flashlight cell
D. C. Voltmeter: 7 Ranges:	0-1.5, 5, 15, 50, 150, 500, 1500 volts full scale. With accessory probe to 30,000 Volts.
Input Resistance:	11 Megohms (1 megohm in probe) on all ranges. 1,100 megohms with accessory probe.
Sensitivity:	7,333,333 ohms per volt on 1.5 Volt range.
Circuit:	Balanced bridge (push-pull) using twin triode.
Electronic AC Voltmeter: 7 Ranges:	0-1.5, 5, 15, 50, 150, 500, 1,500, (1000V Max.) Scales reading R.M.S. (.707 of positive peak).
Circuit:	Diode with adjustable compensation.
Electronic Ohmmeter: 7 Ranges:	Scale with 10 ohms center x1, x10, x100, x1000, x10K, x100K, x1 Meg. Measures .1 ohm to 1,000 megohms with internal battery.

ASSEMBLY AND USE OF THE HEATHKIT VTVM MODEL V-6

PRELIMINARY NOTES AND INSTRUCTIONS: The Heathkit Model V-6 Vacuum Tube Voltmeter is an excellent instrument and care used in construction will be well repaid. The construction is open and easily accomplished, but it should not be rushed, as poor workmanship can easily result in poor operation.

UNPACK THE KIT CAREFULLY AND CHECK EACH PART AGAINST THE PARTS LIST. In so doing, you will become acquainted with the parts. If a shortage is found, attach the inspection slip to your claim and notify us promptly. Screws, nuts, and washers are counted mechanically, and if a few are missing, please secure them locally. Use the charts on the inside covers of this manual to identify the parts.

Read the manual completely through before starting actual construction; in this way, you will become familiar with the general procedure used. Study the pictorials and diagrams to get acquainted with the circuit layout and location of parts. When actually assembling and wiring, read the whole article or step through so that no suggestions will be missed.

To facilitate describing the location of parts, tube sockets, controls, terminal strips, etc. have been lettered and are coded. All such numbering and lettering is clearly shown in the figures and when instructions say for example, "Wire to G3" refer to the proper figure, and connect a wire to pin 3 of socket G.

It is recommended that A, B, C, etc. be actually labeled as such on the chassis with a pencil. Lettering on the inside of the chassis where wiring is done will reduce the possibility of making wrong connections.

Tube socket pins are numbered as shown in Figure 4. Always read clockwise when the socket is viewed from the bottom.

Read the note on soldering on the inside of the back cover. Make a good mechanical joint of each connection with clean metal to clean metal. Use only good quality rosin core radio type solder. Pastes or acids are difficult to remove and minute amounts left combine with moisture from the air forming a corrosive product. Weeks or months later corrosion may result in untimely failure.

A circuit description is included in the later section of this manual so that those with some knowledge of radio will be able to obtain a clearer picture of the actual functioning of this instrument. It is not expected that those with little radio experience will understand the description completely, but it should be of help in the event that they desire to become more familiar with the circuit operation, and thus learn more from building the kit than just the placing of parts and wiring.

NOTE: ALL GUARANTEES ARE VOIDED AND WE WILL NOT REPAIR OR SERVICE INSTRUMENTS IN WHICH ACID CORE SOLDER OR PASTES HAVE BEEN USED.

Small changes in parts may be made by the Heath Company. Any part supplied will work just as well as the part for which it was substituted. By reading the color code or resistors for instance, it will be readily understood that a value of 51,000 ohms is a substitute for the specified 47,000 ohms, etc. provided the specified value is not supplied. Such changes will be made only if the specified parts are unobtainable at the time, and are made to insure a minimum delay in filling your order.

Resistors and controls have a tolerance rating of plus or minus 20% unless otherwise stated. Therefore, a 100K resistor may test between 80K and 120K ohms. The letter K stands for 1000 and M for 1,000,000. Some manufacturers use M for 1000. Consulting the parts list will clarify any parts in question. Thus, a resistor marked 90K=90,000 ohms etc. Frequently condensers show an even greater variation such as minus 50% to plus 100%. This Heathkit is designed to accommodate such variations.

STEP BY STEP ASSEMBLY

The construction of the VTVM is broken down into four parts: chassis parts mounting and wiring, panel parts mounting and wiring, wiring common to both chassis and panel, and test and calibration. If the step-by-step procedure is followed with the aid of the figures and pictorials (for proper placement of parts and lead dress) little difficulty should be encountered in construction.

Check off each step in the space provided (✓) as it is completed.

(S) means solder the connection (NS) means do not solder yet.

MOUNTING OF PARTS ON CHASSIS

Observing Figure 1:

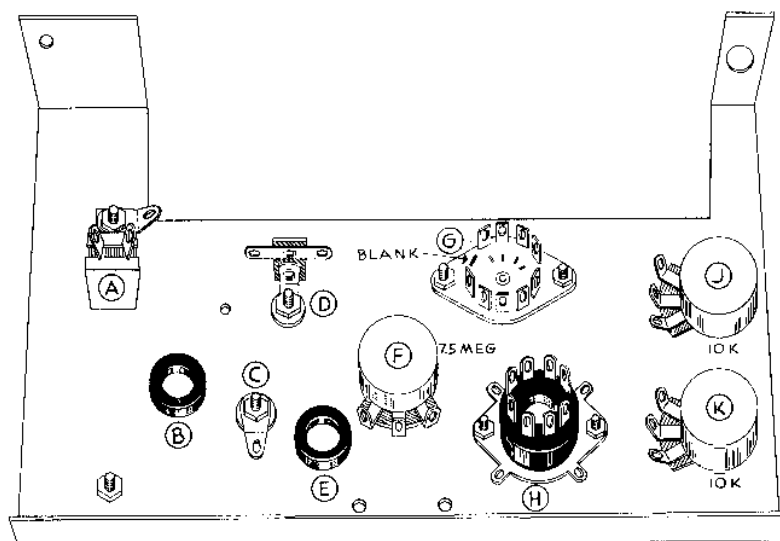

Fig. 1 Mounting of Parts on Chassis

- () Slide a rubber grommet through hole B in the chassis.
- () In a like manner, mount a rubber grommet in position E.
- () Using 3-48 x $\frac{1}{4}$ screws and nuts (use no lockwashers) mount the miniature tube socket in location G. Locate the blank space as shown so as to not have this socket turned around.
- () Using 6-32 screws, lockwashers and nuts, mount the octal tube socket in location H. Locate the keyway in the position shown.
- () Mount a 10K (this may be marked 10M) screw driver slot control in position J. Use a control lockwasher and nut.
- () Mount a 10K (this may be marked 10M) screw driver slot control in position K. Use a control lockwasher and nut.
- () Mount the 7.5 megohm control in position F with a control lockwasher and nut.

Next consult Figure 2 very carefully and note the numbers 1 through 8. If all parts of each step are mounted in sequence, the assembly will go together easily and no parts will interfere with the mounting of parts which follow.

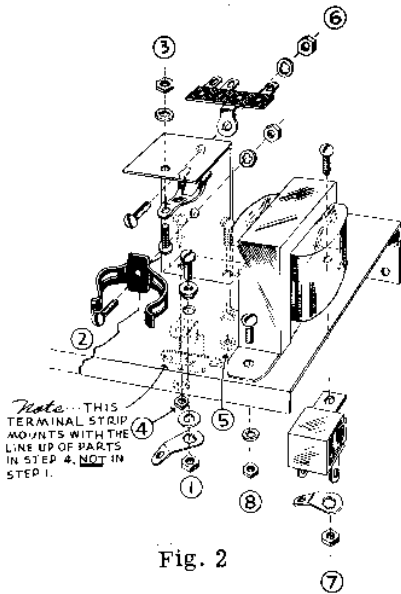

Fig. 2

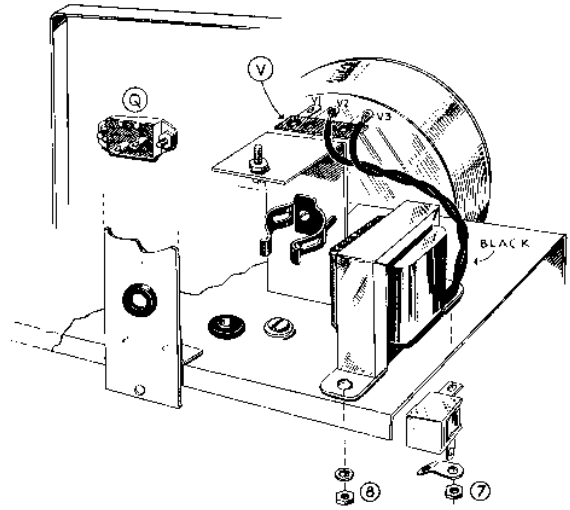

Fig. 3

- () Step 1. In location C, mount the line up of parts consisting of the 6-32 binder head screw, the fibre washer with shoulder as shown, the flat fibre washer, the solder lug and a nut.
- () Step 2. Mount the battery spring clamp to the Z angle bracket, by means of a 4-40 screw, lockwasher and nut.
- () Step 3. Mount the battery base clip to the Z angle bracket by means of a 4-40 screw, lockwasher and nut.
- () Step 4. In location D, mount the line up of parts consisting of a 6-32 screw, Z angle bracket, (chassis), a lug terminal strip, lockwasher and nut.
- () Step 5. Mount the line up of parts consisting of a 6-32 screw, lockwasher and nut.
- () Step 6. Fasten the 3 lug terminal strip to the Z bracket by means of a 6-32 screw, lockwasher and nut. See Figure 3.
- () Step 7. The power transformer is next. First pass the two red and the two yellow leads through grommet B, and leave the two black leads above the chassis. In location A, (see Figures 2 and 3) pass a 6-32 screw through the transformer flange and chassis, and fasten the rectifier to the chassis with a solder lug and nut. Be sure the rectifier is oriented as shown and is not turned around.
- () Step 8. Fasten the other transformer mounting flange to the chassis by means of a 6-32 screw, lockwasher and nut.

WIRING OF CHASSIS

IMPORTANT NOTE: WHEN A TUBE IS FIRST OPERATED, ITS CHARACTERISTICS ARE NOT AS STABILIZED AS AFTER A PERIOD OF "AGING." THEREFORE, EACH 6H6 HAS BEEN "AGED" AND ITS ACTUAL OPERATING CHARACTERISTICS DETERMINED AT THE HEATH COMPANY. THIS AGING AND TESTING PROCESS IS PERFORMED SO THAT THE KIT BUILDER WILL BE ABLE TO MAKE A GOOD INITIAL CALIBRATION AND WILL BE ABLE TO CONNECT THE DUO-DIODE (6H6) IN A MANNER WHICH WILL CAUSE HIS INSTRUMENT TO OPERATE WITH OPTIMUM PERFORMANCE. THUS, IN THE INSTRUCTIONS WHICH FOLLOW, IF THE 6H6 CARTON HAS THE WORDS "REVERSED DIODES" STAMPED ON IT IN LARGE LETTERS, SKIP ALL STARRED STEPS (*), AND PERFORM THOSE STEPS WHICH START OUT "REVERSED DIODES." FOLLOW THOSE PICTORIALS WHICH ARE CLEARLY LABELED "REVERSED DIODES."

IF THE 6H6 CARTON DOES NOT HAVE THE WORDS "REVERSED DIODES" STAMPED ON IT IN LARGE LETTERS, PERFORM THE STARRED (*), AND SKIP THE STEPS WHICH START OUT "REVERSED DIODES." FOLLOW THOSE PICTORIALS WHICH ARE NOT LABELED "REVERSED DIODES."

PICTORIAL 2 SHOULD BE FOLLOWED REGARDLESS OF 6H6 CARTON MARKING. PICTORIALS 1 AND 3 AND PICTORIALS "1 REVERSED DIODES" AND "3 REVERSED DIODES" SHOULD BE FOLLOWED ACCORDING TO 6H6 CARTON MARKING.

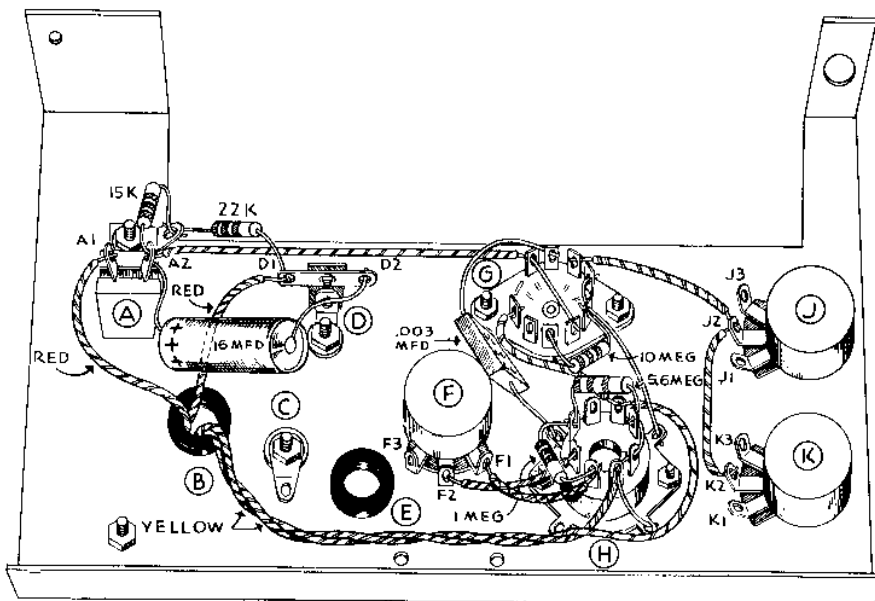

Pictorial 1 Starred (*) Steps Apply - Wiring of Chassis

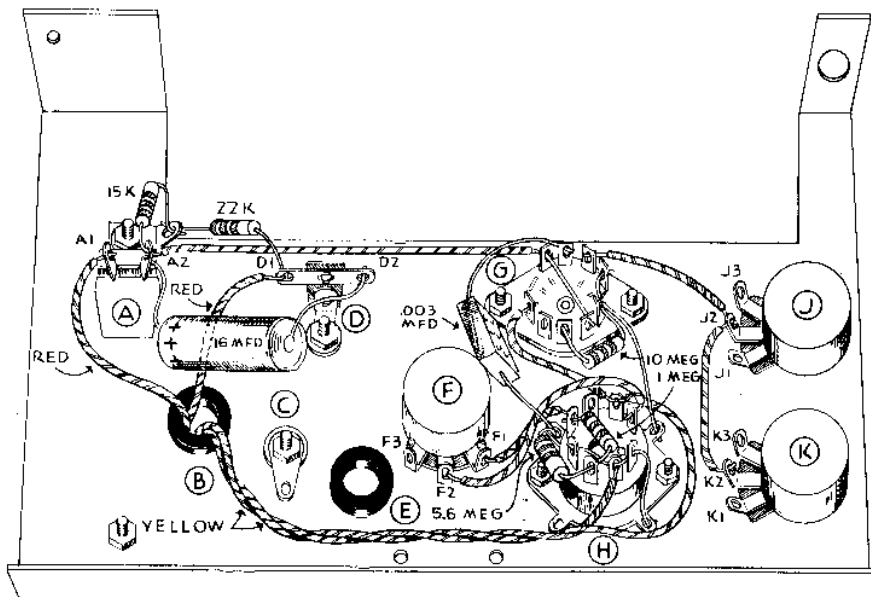

Pictorial 1 Reversed Diodes - Wiring of Chassis

When connecting the transformer leads, before cutting, run each lead to its connecting point and leave sufficient wire for making the connection. Pictorial 1 shows chassis wiring.

- () Connect one red lead of the power transformer to A1 (S).
- () Connect the other red lead to D1 (NS).
- () Twist together the two yellow leads and connect one to H7 (NS).
- () The other yellow lead goes to H2 (NS).
- () Twist together the two black leads and connect one to V2 (NS). See Figure 3.
- () The other black lead goes to V3 (NS).
- () Run a wire from A2 (NS) to G1 (NS).
- () Connect a 22K resistor between D1 (S) and the solder lug in location A (NS).
- () Connect a 15K resistor between A2 (NS) and the solder lug in location A (S).
- () Connect the positive lead (marked positive or with +++) of a 16 MFD condenser to A2 (S) and the other lead to D2 (NS).
- () Run a short bare wire jumper from G1 (S) to G6 (S). Keep this jumper far enough from the pin socket holes so that it will not interfere with the tube pins when the tube is plugged in.
- () Connect a piece of bare wire to G4 (NS), run it through G5 (NS), and connect it to the nearby ground lug on socket H (S).
- () Connect a 10 Megohm resistor between G7 (S) and G5 (S).
- () Run a wire from G9 (NS) to H7 (S).
- () Run a wire from G3 (NS) to J2 (NS).
- () Run a wire from J2 (S) to K2 (S).
- * () Run a wire from H3 (NS) to F1 (S).
- () Reversed Diodes: Run a wire from H5 (NS) to F1 (S).
- * () Run a wire from H4 (S) to F2 (S).
- () Reversed Diodes: Run a wire from H8 (S) to F2 (S).
- * () Connect a 1 Megohm resistor from H3 (S) to H5 (NS).
- () Reversed Diodes: Connect a 1 Megohm resistor from H3 (NS) to H5 (S).
- * () Connect the .003 MFD condenser between G2 (NS) and the nearby ground lug on socket H (S).
- () Reversed Diodes: Connect the .008 MFD condenser between G2 (NS) and the nearby ground lug on socket H (NS).
- * () Connect a piece of short bare wire to H8 (NS), pass it through H1 (S), pass it through H2 (S), and continue it to the nearby ground lug on socket H (S).
- () Reversed Diodes: Connect a piece of short bare wire to H4 (S), pass it through H2 (S), pass it through H1 (S), and continue it to the nearby ground lug on socket H (S). Keep clear of H3.
- * () Connect a 5.6 Megohm resistor between H5 (NS) and H8 (S).
- () Reversed Diodes: Connect a 5.6 Megohm resistor between H3 (NS) and the nearby ground lug on Socket H (S).

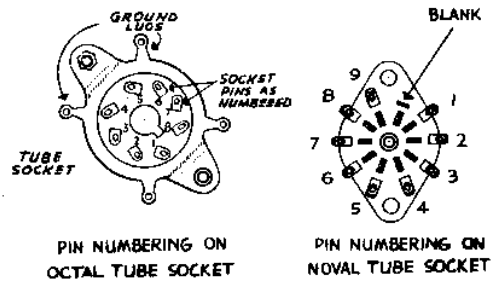

Fig. 4

MOUNTING OF PARTS ON PANEL

Note Figure 5 for the proper placement of switches, controls, etc. on the panel. Place all contacts and lugs in the same relative positions as shown in figure.

- () Mount the OFF-ON switch in position Q using 6-32 screws, lockwashers and nuts. Make certain that the lugs protruding from the back are as shown (so as to not mount the switch upside down by mistake).
- () Note Figure 6 and mount the red banana jack in location U. Slide the insert into the jack and crimp it to prevent pulling out.
- () Consult Figure 7 and mount the phone jack assembly in position T. Be sure the positioning of lugs is exactly as shown in Figure 5. Otherwise shorting might occur when the panel is placed on the cabinet.

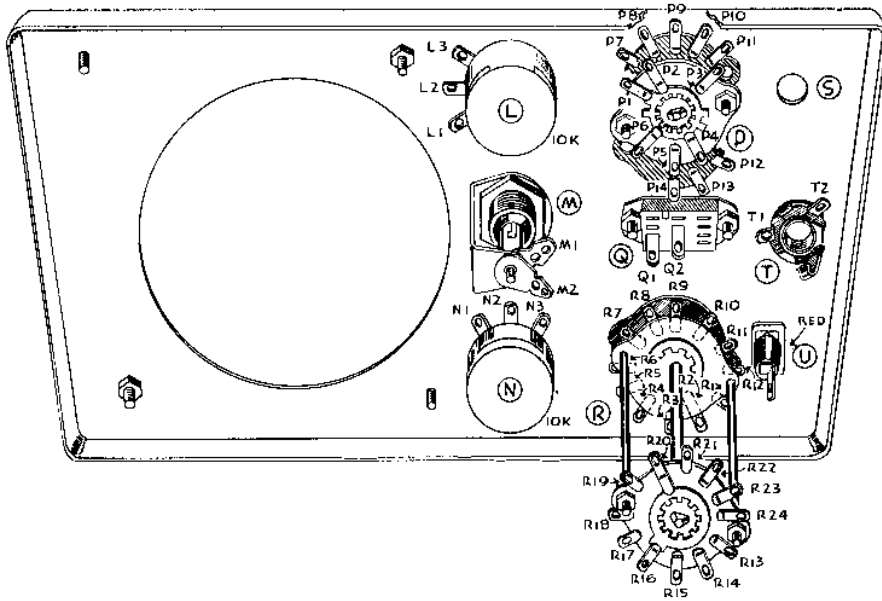

Fig. 5 Mounting of Parts on Chassis

- () Consult Figure 8 and mount the pilot light assembly on position M.
- () Mount a 10K control in position L. See Figure 9.
- () Mount the other 10K control in position N.
- () Mount the selector switch in location P. Keep the position of the lugs exactly as shown in Figure 5.



Fig. 6

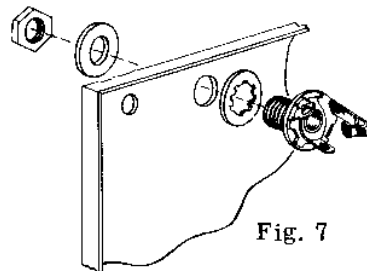

Fig. 7

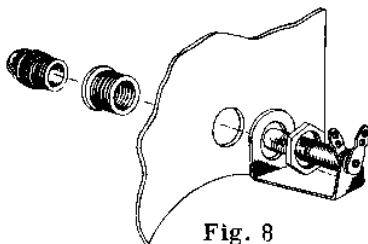

Fig. 8

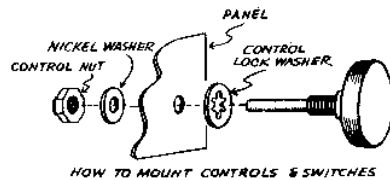

Fig. 9

WIRING OF RANGE SWITCH

The range switch is wired before it is placed on the panel. The two deck arrangement makes all wiring open and easy to accomplish. Follow the switch lug numbering carefully and double check each resistor for position and value before soldering it into place. Switch lug marking follows a definite pattern—this is shown in Figure 10. Lugs are numbered clockwise and run from 1 to 12 on the front deck and from 13 to 24 on the rear deck. The long lug (flanked on each side with a dummy lug) on the front deck is lug number two. Referring to this lug will prevent inadvertently wiring the switch backwards or incorrectly. Looking at Figure 10, number the lugs with a pencil.

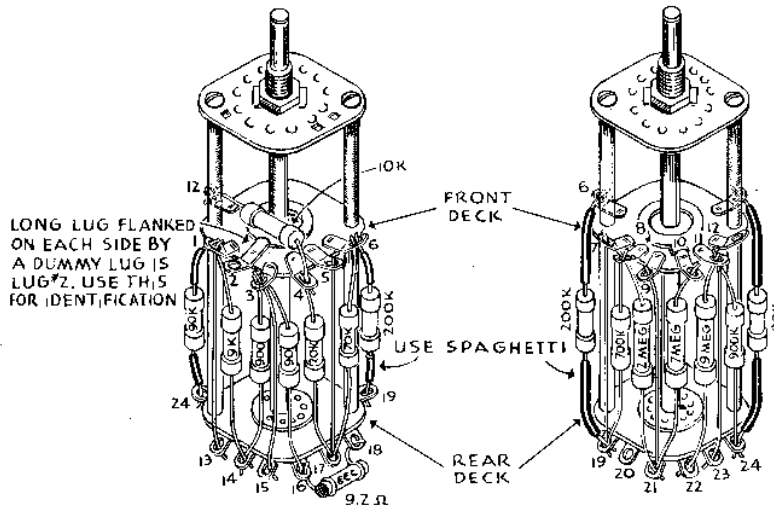
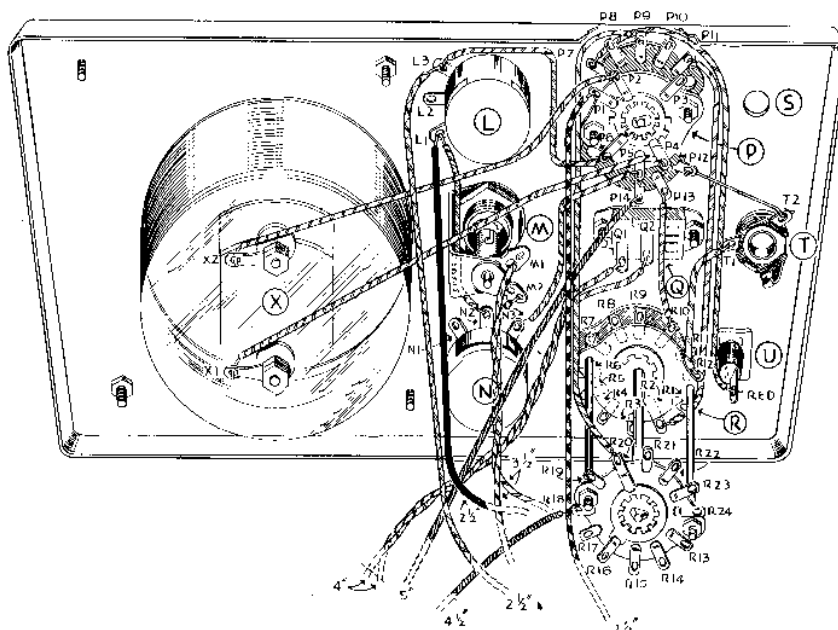

Fig. 10

- () Connect a short bare wire jumper from R1 (NS) to R13 (S).
- () Connect the 9K resistor from R1 (NS) to R14 (NS).
- () Connect the 900 Ohm resistor from R3 (NS) to R14 (S).
- () Connect a short bare wire jumper from R3 (NS) to R15 (S).
- () Connect the 90 Ohm resistor from R3 (S) to R16 (NS).
- () Connect the 20K resistor from R4 (NS) to R17 (NS).
- () Connect the 10K resistor from R4 (S) to R12 (NS).
- () Connect a bare jumper from R5 (S) to R17 (NS).
- () Connect the 70K resistor from R6 (NS) to R17 (S).
- () Connect the 9.2 Ohm resistor from R16 (S) to R18 (NS).
- () Connect the 200K resistor from R6 (S) to R19 (NS). Be sure that the resistor leads cannot short to the switch wafer spacers. Use spaghetti if necessary.
- () Connect a short bare wire jumper from R7 (S) to R19 (NS).
- () Connect the 700K resistor from R8 (NS) to R19 (S).
- () Connect the 2 Megohm resistor from R8 (S) to R21 (NS).
- () Connect a short bare wire jumper from R9 (S) to R21 (NS).
- () Connect the 7 Megohm resistor from R10 (NS) to R21 (S).
- () Connect the 9 Megohm resistor from R11 (NS) to R22 (S).
- () Connect a short bare wire jumper from R11 (NS) to R23 (S).
- () Connect the 900K resistor from R11 (S) to R24 (NS).
- () Connect the 90K resistor from R24 (S) to R1 (S). Be sure that the resistor leads cannot short to the switch wafer spacers. Use spaghetti if necessary.
- () Mount the range switch on the panel in location R. Be sure AND HAVE THE LONG LUG ON THE REAR DECK located as shown in Figure 5 and Pictorial 2.

WIRING OF PANEL (See Pictorial 2)

- () Run a wire (keep close to chassis) from P11 (S) to R2 (S).
- () Run a wire (keep close to chassis) from P9 (S) to R20 (S).
- () Run a wire (keep close to chassis) from P7 (S) to the insert solder lug of red banana jack in location U (S).
- () Connect a short bare wire jumper between P12 (S) and T2 (S).
- () Run a wire from P13 (S) to R10 (S).
- () Run a wire from R12 (S) to T1 (NS).
- () Run a wire from P6 (S) to L3 (NS).
- () Run a wire from P5 (S) to N3 (S).
- () Run a wire from L1 (NS) to N2 (S).



Pictorial 2 Wiring of Panel

- 2) Connect a $2\frac{1}{2}$ " length of wire to L3 (S). Leave the other end free.
- 2) Connect a $2\frac{1}{2}$ " length of wire to L1 (S). Leave the other end free.
- 2) Connect a $2\frac{1}{2}$ " length of wire to P1 (S). Leave the other end free.
- 2) Connect a 5" length of wire to P14 (S). Leave the other end free.
- 2) Connect a $4\frac{1}{2}$ " length of wire to R18 (S). Leave the other end free.
- 2) Twist together two wires to form a twisted pair $3\frac{1}{2}$ " long. At one end of this pair, connect one wire to M1 (S), and connect the other wire to M2 (S). Leave the other end of the pair free.
- 2) Twist together two wires to form a twisted pair 4" long. At one end of this pair, connect one wire to Q1 (S), and connect the other wire to Q2 (S). Leave the other end of the pair free.
- () Slide the meter through the opening provided in the panel (location X); the four meter mounting screws will slide through the four holes provided. Check to see that the meter is placed correctly (not upside down).
- () Fasten the meter in place with a lockwasher and nut on two of the meter mounting screws as shown in Pictorial 2. Lockwashers and nuts do not go on the other two screws at this time.
- () Run a wire from P4 (S) to X1 (S).
- () Run a wire from P2 (S) to X2 (S).
- () Note in Figure 11 the manner in which the chassis mounts to the panel. Slide the large chassis mounting flange over a meter mounting screw as shown and fasten with a lockwasher and nut.
- () Line up the hole in smaller chassis mounting flange with the hole in the panel, slide the black banana jack into position, and force the speednut into place so that the bracket and flange are held firmly together.
- () Slip the banana jack insert into the black banana jack. Crimp the insert to prevent it from pulling out. See Figure 6.

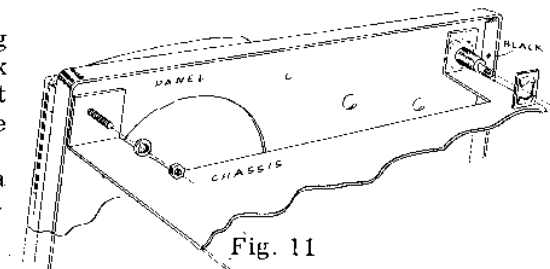

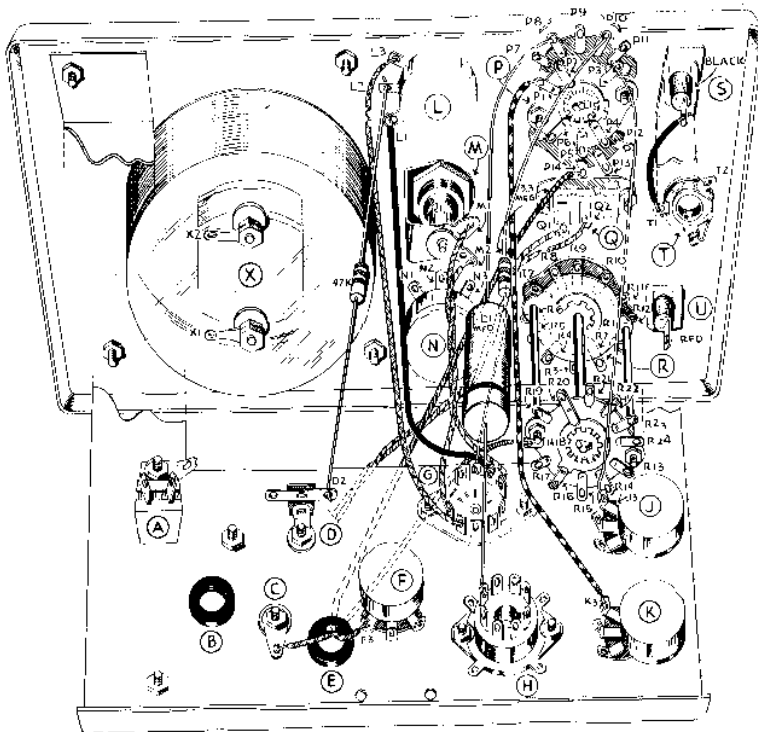

Pictorial 3 Starred (*) Steps Apply—Wiring Common to Both Chassis and Panel.

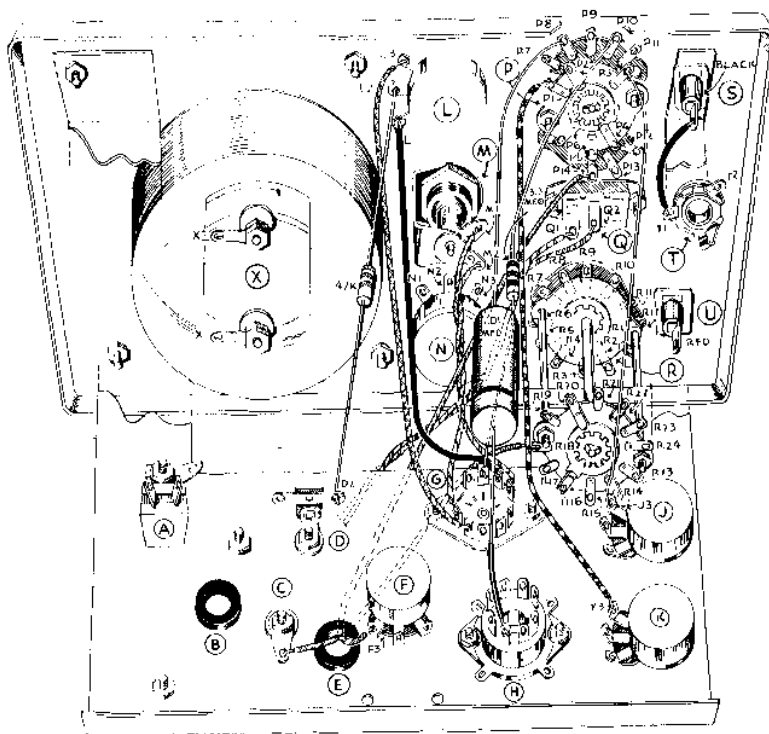

Pictorial 3 Reversed Diodes—Wiring Common to Both Chassis and Panel

WIRING COMMON TO BOTH PANEL AND CHASSIS.

- () The free end of the $2\frac{1}{2}$ " length of wire on L1 connects to G3 (S).
- () Connect a 47K resistor from L2 (S) to D2 (S).
- () The free end of the $2\frac{1}{2}$ " length of wire to L3 connects to G8 (S).
- () Connect one free lead of the $3\frac{1}{2}$ " twisted pair which is on pilot light M to G9 (S).
- () Connect the other free lead of the pilot light $3\frac{1}{2}$ " twisted pair to G4 (S).
- () Pass the free end of the 5" length of wire on P14 through grommet E and connect it to F3 (S).
- () Pass the free end of the $4\frac{1}{2}$ " length of wire on R18 through grommet E and connect it to solder lug C (S).
- () Study Figure 12 and connect one free lead of the 4" twisted pair which is on the OFF-ON switch (location Q) to V1 (NS).
- () Connect the other free lead of the OFF-ON switch 4" twisted pair to V2 (S).
- () The free end of the $2\frac{1}{2}$ " length of wire on P1 connects to K3 (S).
- () Run a short bare wire jumper from P3 (S) to J3 (S).
- () Run a wire from T1 (S) to the insert solder lug of black banana jack in location S (S).
- () Connect a 3.3 Megohm resistor from P10 (S) to G2 (S).
- * () The outside foil lead of the .01 MFD condenser connects to H5 (S) and its other lead goes to P8 (S).
- () Reversed Diodes; the outside foil lead of the .01 MFD condenser connects to (use spaghetti) H3 (S) and its other lead goes to P8 (S).

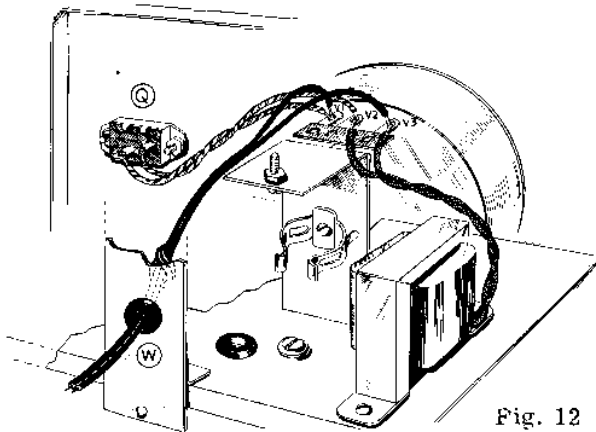

Fig. 12

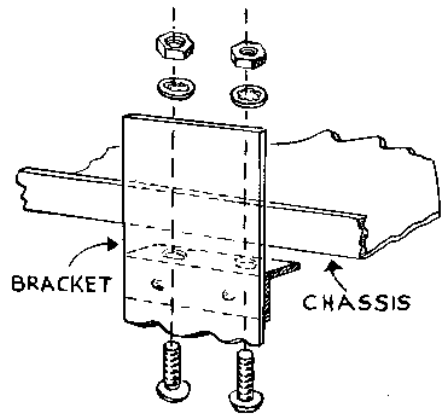

Fig. 13

- () The large L mounting bracket should now be mounted on the chassis with two 6-32 screws, lockwashers and nuts (see Figure 13 for detail). The L bracket mounts to the panel by means of a meter mounting screw, lockwasher and nut.
- () Note Figure 12 and pass a $3/8$ " rubber grommet through the hole in location W.
- () Pass the line cord through grommet W, and knot it as shown. The knot will provide strain relief should the cord be accidentally jerked.
- () Split the line cord slightly and connect one lead to V1 (S).
- () Connect the line cord's other lead to V3 (S).

PREPARATION OF TEST LEADS

- () Common test lead. The common test lead is made by connecting the black banana plug on one end of the black test lead, and an alligator clip on the other. Figure 14 shows the detail.

COMMON TEST LEAD



Fig. 14

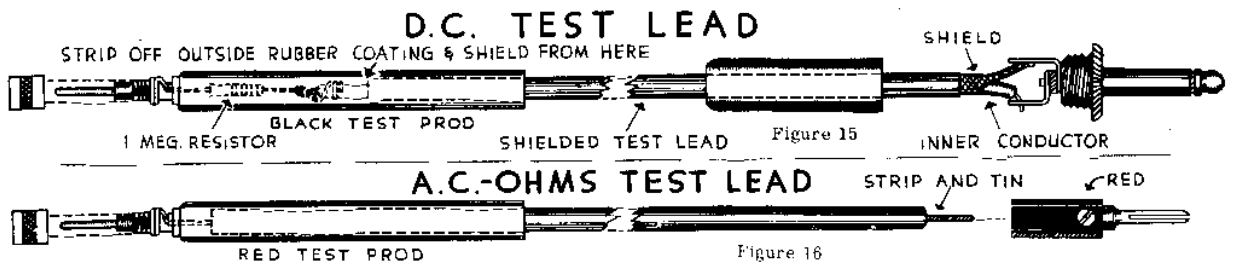

- () DC test lead. The DC test lead is made by connecting the phone plug on one end of the shielded test lead. On the other end goes a small 1 megohm resistor which is then slipped inside the black test prod. See Figure 15.
- () AC-Ohms test lead. The AC-Ohms test lead is made by connecting the red banana plug on one end of the red test lead, and the red test prod on the other. Figure 16 shows the construction.
- () Fasten the handle on the case using two 10-24 screws.
- () Push the rubber feet into the four holes in the bottom of the case.
- () Slide the acorn knobs over the shafts of the zero adjust and ohms adjust controls and tighten down the small set screw in each.
- () Turn both switches maximum counterclockwise and slide the two pointer knobs over the shafts and tighten down the small set screw while the pointer knobs are indexed properly i.e. pointing correctly.



Fig. 17

IMPORTANT WARNING

Miniature tubes can be easily damaged when plugging them into their sockets. Therefore, use extreme care when installing them. WE DO NOT GUARANTEE OR REPLACE MINIATURE TUBES BROKEN DURING INSTALLATION.

- () Plug the 12AU7 in socket G and the 6H6 in socket H (See warning above). This completes the wiring of the kit and the instrument is now ready to test and calibrate.

TEST AND CALIBRATION

Check over the wiring carefully. We suggest tracing over each wire on the pictorial with a colored pencil as it is checked on the instrument. Check each solder connection. Install the tubes.

Plug the instrument into a 117 Volt 50/60 Cycle AC ONLY outlet. This instrument will not operate, and serious damage will result, if plugged into a DC outlet.

Turn the switch on and allow a minute for warm up. Set the selector switch to DC+. Check operation of zero adjust control. Turning this control should move the meter pointer to about half or $\frac{3}{4}$ scale and to zero. Set pointer to zero and check if it remains on zero when switched to DC-. If there is appreciable zero shift (more than one or 2 divisions on the scale) the tubes must be aged. First complete the initial test, however.

Turn the instrument off and make sure the mechanical zero of the meter is correct. If not, adjust as follows: Place the instrument in normal operating position. (This usually is with the rubber feet on a level surface.) Turn the black plastic screw on the meter face with a screwdriver, while gently tapping the meter face with one finger, until the pointer coincides with the zero line on the left side of the scale. Turn the instrument on again.

Insert the common and DC test leads. Set the selector switch to DC+ and the range switch to 1.5V. Connect the test leads to the calibrated flashlight cell, and adjust the DC calibrate control (See Figure 18) so the meter pointer falls directly over the very small red dot on the meter face. (See Figure 19). Approach the red dot going up scale i.e., turn the calibrate control and watch the meter read 1.4V and 1.5V and then the red dot. As soon as the red dot is reached, stop turning the calibrate control. Remember the range switch must be set on 1.5V.

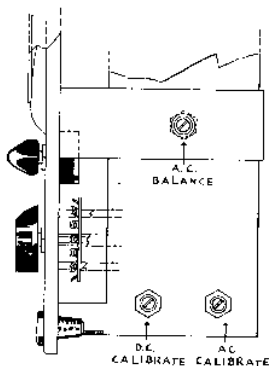

Fig. 18

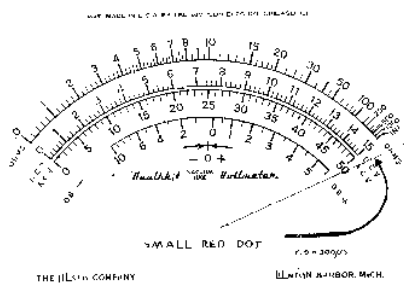

Fig. 19

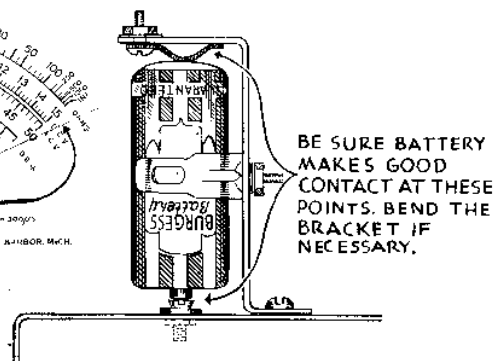

Fig. 20

Turn instrument OFF and install the battery in the battery bracket as shown in Figure 20. Turn instrument ON and let it warm up. Set selector switch to ohms. Pointer should swing to about full scale. Turn ohms adjust to give full scale reading (Infinite). Insert AC ohms test lead. Touch this lead to common lead and observe pointer dropping to zero indicating short circuit (no resistance).

Temporarily remove AC-ohms test lead. Set range switch to 1.5V and selector to AC. Adjust AC balance control so no movement is noticed in the pointer when switching from AC through DC- to DC+. Now set range switch to 150V and the selector switch to AC. Re-insert AC ohms lead. Connect AC ohms and common lead to the 117V AC line (NOTE: 117 Volt line is dangerous--proceed with due care) and adjust AC calibrate control so pointer indicates the line voltage.

It is recommended that the tubes be aged before final calibration. This is accomplished by keeping the instrument turned on for a period of at least 48 hours. Final calibration should be done in the same way as initial calibration. Careful calibration will result in a more accurate instrument. If a standard AC meter is available, it is desirable to use such an instrument, preferably at a voltage near full scale indication on the VTVM, as for instance 140 Volts or 40 Volts (on the 150V or 50V range respectively).

After final calibration, place the instrument in the cabinet, and install two sheet metal screws through the back and into the chassis. The instrument is now ready for use.

CIRCUIT DESCRIPTION

The meter is in the cathode circuits of a twin triode. The zero adjust control sets up a balance between the two sections of the triode such that with zero input voltage applied to the first grid, the voltage drop across each portion of the adjust control (from adjust arm to one side, and adjust arm to the other side) is the same. This being true, the meter reads zero. With a voltage applied to the first grid, the balance in the cathode circuits is upset and the meter indicates. The relationship between the test voltage applied to the first grid and the meter indicating current is linear, and therefore the meter is calibrated with a linear scale. The advantage of having the meter in a vacuum tube circuit of this kind is that voltages to be measured are not applied directly to the meter but rather to the tube. Because the tube is limited to the amount of current it can draw, the meter movement is protected.

Calibration of the instrument is simple and is accomplished by adjustment of the AC and DC calibrate controls. These controls are in series with the meter and are adjusted to produce full scale reading with the proper test voltage applied to the instrument.

The maximum test voltage which is applied to the tube is about 3 volts. Higher test voltages are reduced by a voltage divider which has a total resistance of 10 megohms. An additional resistance of 1 megohm is located in the DC test prod thereby permitting measurements to be made in circuits carrying RF with a minimum disturbance of such circuits.

For AC voltages in the Audio Frequency range, a shunt fed diode is used to provide a DC voltage proportional to the peak of the applied AC voltage. This DC voltage is applied through the voltage divider to the tube, causing the meter to indicate. The AC calibrate control is used so as to obtain the proper meter deflection for the applied AC voltage. Vacuum tubes develop a contact potential voltage between tube elements. Such contact potential developed in the diode would cause a slight voltage to be present at all times. This voltage is canceled out by bucking it with a portion of the contact potential of a second diode. The amount of bucking voltage is controlled by the AC balance control. This eliminates zero shift when switching from DC to AC.

For resistance measurements, a $1\frac{1}{2}$ Volt battery is connected through a string of multipliers of 1% tolerance and the external resistance to be tested, thus forming a voltage divider across the battery. A resultant portion of the battery voltage is applied to the twin triode. The meter scale is calibrated in resistance.

USING THE VTVM

NOTE: As the heaters are operated at a low temperature, the tube life is extremely long. The power consumption is very low. We therefore recommend that this instrument be turned on at the same time as the soldering iron for instance, and left on until the work is done. This will result in very stable operation, and the slight amount of heat generated inside the cabinet will keep the instrument free from moisture in humid climates.

The VTVM has many advantages over the non-electronic volt-ohmmeters. The greatest advantage is the high input resistance. This enables much more accurate readings to be obtained in high impedance circuits, such as resistance coupled amplifiers, oscillator grid circuits and AVC networks.

To illustrate this, let us assume a resistance coupled audio amplifier with a .5 megohm plate load resistor, operating with a 100 Volt plate supply. Let us also assume that the tube acts as a .5 megohm resistor. Measuring the plate voltage with a conventional 1,000 ohm per volt instrument on the 100 Volt scale, the meter can be considered a 100,000 ohm (.1 megohm) resistor in parallel with the tube. The voltage on the plate is then about 14 Volts and is shown as such by the meter. This is due to the shunt resistance of the low resistance meter. Using the VTVM on any scale setting, the full 11 megohms is placed in parallel with the tube. The voltage on the plate is then about 49 Volts or 2% lower than the normal operating voltage. Thus accurate reading can only be obtained with the high resistance provided by a VTVM.

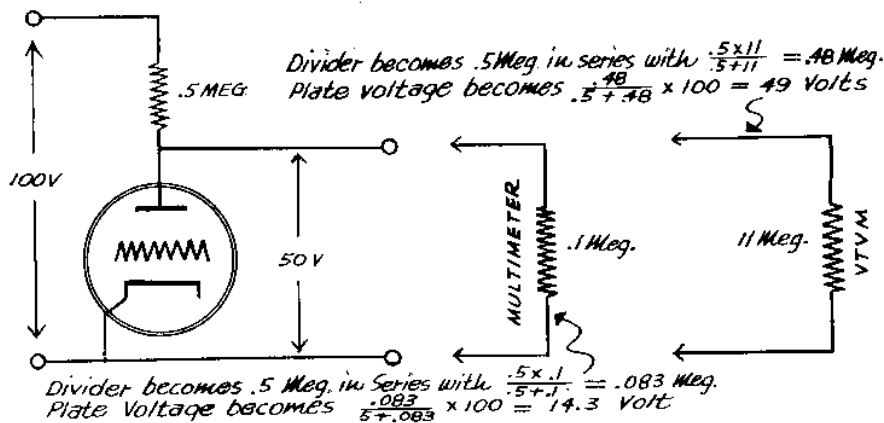

An understanding of the characteristics of your instrument will result in greater satisfaction through proper use.

DC VOLTAGE

To measure DC voltage with the VTVM, connect the common (black) lead to the common or "cold" side of the voltage to be measured. Set the selector switch to DC+ or DC- as required and set the range switch to a range greater than the voltage to be measured, if known. If unknown, set to 1,500 Volts. With black test prod, touch other or "hot" side of the voltage to be measured. If pointer moves less than one-third of full scale, switch to the next lower range.

AC VOLTAGE

IMPORTANT WARNING: THE 1500V MARKING ON THE LAST SCALE APPLIES TO DC VOLTAGES ONLY. VOLTAGES IN EXCESS OF 1000V AC MUST NOT BE APPLIED TO THE VTVM. THIS WARNING IS CLEARLY SHOWN ON THE PANEL AND MUST BE OBSERVED. THE HEATH COMPANY ASSUMES ABSOLUTELY NO RESPONSIBILITY NOR OBLIGATION FOR ANY DAMAGES TO INSTRUMENT CAUSED BY APPLYING AC VOLTAGES IN EXCESS OF 1000 VOLTS TO THE VTVM.

To measure AC voltage with the VTVM, connect the common (black) lead to the common or "cold" side of the voltage to be measured. Set the selector switch to AC, and set the range switch to a range greater than the voltage to be measured, if known. If unknown, set to 1,500 Volts. With red test prod, touch other or "hot" side of the voltage to be measured. **DO NOT MEASURE AC VOLTAGES IN EXCESS OF 1000V.** If pointer moves less than one-third of full scale, switch to the next lower range.

The Heathkit is an extremely sensitive electronic AC voltmeter and as the human body picks up AC when near any AC wires, the meter will indicate this pickup. Never touch the AC prod when on the lower ranges. Zero should be set with the AC prod shorted to the common clip.

RESISTANCE

To measure resistance with the VTVM, connect the common (black) lead to one side of the resistor to be measured. Set the selector to ohms, and set the range switch to such a range that the reading will fall as near to mid-scale as possible. Set the ohms adjust control so the meter indicates exactly full scale (INF, on ohms scale). Then touch the red test prod to the other side of the resistor to be measured. Read resistance on ohms scale and multiply by the proper factor as shown by the range switch setting.

NOTE: Although batteries are used to measure resistance, the indication is obtained through the electronic meter circuit, and therefore, the instrument must be connected to the AC power line and tuned on.

CAUTION: Never leave the instrument on ohms, as it greatly shortens the life of the ohmmeter battery.

USING THE VTVM DECIBEL SCALE

Because the human ear does not respond to volume of sound in proportion to signal strength, a unit of measure called the "bel" was adopted. The "bel" is more nearly equivalent to human ratios. Normally the reading is given in 1/10 of a "bel" or decibel."

Various signal levels are adopted by various manufacturers as standard or "0" decibels.

The Heathkit VTVM DB scale uses a standard of 1 milliwatts into a 600 ohm line as "0" decibels. This corresponds to .774 VAC on the 0-1.5V scale. From this figure, the various AC ranges of the VTVM may be converted to db by the following chart:

AC VOLTS SCALE	DECIBEL SCALE
0-1.5V	Read db directly
0-5V	Add 10 db to the reading
0-15V	Add 20 db to the reading
0-50V	Add 30 db to the reading
0-150V	Add 40 db to the reading
0-500V	Add 50 db to the reading
0-1500V (1000V AC max.)	Add 60 db to the reading

As the decibel is a power ratio or voltage ratio, it may be used as such without specifying the reference level. Thus for instance, a fidelity curve may be run on an amplifier by feeding in a signal of variable frequency but constant amplitude. At a reference frequency of say 400 cycles, adjust input to give a convenient indication (0 db for instance) on the VTVM connected to the output. As the input frequency is varied, the output level variation may be noted directly in db above and below the specified reference level.

NOTE: When measuring complex AC wave shapes, such as ripple, hum, distorted and square waves, the indication is 70% of the positive peak.

READING THE METER SCALE

The voltage markings on the range switch refer to the FULL SCALE reading. The scale is marked 0-15 and 0-50 for voltage. On the 1.5 Volt range, read the 0-15 scale and move the decimal one place to the left. Thus, for example, a reading of 8 would represent a voltage of .8 volts. On the 5V range, read the 0-50 scale and move the decimal one place to the left (i.e., drop the zero). A reading of 40V would represent a voltage of 4 volts. On the 15V range read the 0-15 scale directly (example, a reading of 4V represents a voltage of 4V). On the 50V range read the 0-50V directly. On the 150V range, read the 0-15 scale and add one zero (example, a reading of 12 represents a voltage of 120V). On the 500V range read the 0-50 scale and add one zero (example, a reading of 40 represents a voltage of 400V). On the 1500V range read the 0-15 scale and add two zeros (example, a reading of 8 represents a voltage of 800V).

NOTE: This marking does not mean that the upper scale indicates ACV and the lower scale DCV. Rather, it means that either scale will read ACV or DCV, depending on the setting of the selector switch.

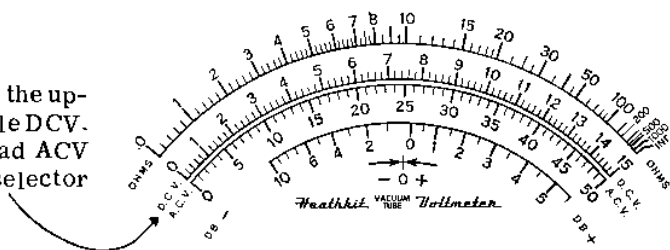

The resistance marking or ohms scale refers to the lowest resistance range (Rx1). For the other ranges, add the proper number of zeros (add two zeros for Rx100, add four zeros for Rx10K, add six zeros for Rx1 Meg). On the Rx1 Meg range, the scale can also be considered to read directly in megohms.

ACCURACY

The accuracy of the meter movement is within 2% of full scale, which means that, for instance on the 1000 Volt range the accuracy of the movement will be within 20 Volts at any point on the scale. On DC, the accuracy of the multiplier (1%) may be additive, resulting in an accuracy of within 3% of full scale.

On AC, the accuracy of the rectifier circuit contributes variations which result in accuracy of within 5% of full scale.

The accuracy on the ohms ranges depends on the meter accuracy, the ohms multiplier accuracy (including the internal resistance of the batteries), and the stability of the battery voltage. On the Rx1 scale, the internal resistance of the batteries and the battery voltage both vary as result of the current drawn by the resistance under test. For greatest accuracy, tests on low resistance values should be made as quickly as possible. On the higher ohms ranges, the accuracy depends practically on the multipliers, which are 1%, and the meter movement accuracy. Because of the non-linear ohms scale, the resulting accuracy is not readily expressed in a percentage figure, but the greatest accuracy is obtained at mid-scale readings.

NOTE: When comparing this instrument with another instrument, consider that the accuracy of the other instrument may deviate in the opposite direction. Therefore, when comparing two instrument of 5% accuracy, the difference might be a total of 10%. Critical comparisons should only be made against certified laboratory standards.

IN CASE OF DIFFICULTY

1. Recheck the wiring. Most cases of trouble result from wrong or reversed connections. Often having a friend check the wiring will reveal a mistake consistently overlooked.
2. Check the tubes.

The possibility exists that a perfectly balanced tube will not permit Zero center adjustment on either DC+ or DC-. Then add 1000 ohms or more in series with either 12AU7 cathodes and the Zero adjust control.

3. If the pointer swings full scale to the right and stays there with switch set to DC+, check for an open circuit or high resistance connection somewhere between the grid pin #2 of the 12AU7 and ground. This might be due to a wrong connection to the selector switches, a poor connection, or possibly an open resistor.

If the instrument does not operate on any function, a check of the power supply, and the 12AU7 and its associated meter circuit is suggested.

If the instrument only fails to function on AC measurements, then a check of the 6H6 and its associated circuits should be made.

If the instrument only fails to function on ohms, the difficulty will probably be due to the battery (make certain the battery is making good contact in the bracket) or the ohms multipliers.

Proper operation on DC should first be secured before an attempt is made to use the instrument on AC or ohms.

4. Check the operating voltages. The following voltages are measured to chassis: Pin #1 or #6 on 12AU7 tube or + lug on rectifier 35-70 Volts positive. Negative lug on rectifier 70-110V negative. Pin 7 of 6H6 and pin 9 of 12AU7, 5-6V AC.
5. Check continuity through the DC test cable. Make certain that the shielding is not shorted to center conductor.

Should inspection reveal the necessity for replacement of a component, write to the Heath Company immediately. The following information should be supplied in all cases:

- A. Thoroughly identify the part in question by using the part number and description found in the manual parts list.
- B. Identify the type and model number of kit in which it is used.
- C. Mention the order number and date of purchase.
- D. Describe the nature of defect or reason for requesting replacement.

The Heath Company will promptly supply the necessary replacement. Please do not return the defective component until specifically requested to do so. Do not under any circumstances dismantle the component in question as this will void the guarantee. If tubes are to be replaced, pack them carefully to prevent breakage in shipment as broken tubes are not eligible for replacement.

SERVICE

In event continued operational difficulties of the completed instrument are experienced, may we remind you that the facilities of the Heath Company Service Department are at your disposal. Your instrument may be returned for inspection and repair for a service charge of \$3.00 plus the cost of any additional material that may be required. **THIS SERVICE POLICY APPLIES TO COMPLETED INSTRUMENTS CONSTRUCTED IN ACCORDANCE WITH THE INSTRUCTIONS AS STATED IN THE MANUAL.** Instruments that are not completed or instruments that are modified will not be accepted for repair. Instruments showing evidence of acid core solder or paste fluxes will be returned, not repaired.

The Heath Company is willing to offer its utmost cooperation to assist you in obtaining the proper operation of your instrument and therefore the factory repair service is available for a period of one year from the date of purchase.

NOTE: Before returning this unit, be sure that all parts are securely mounted. Attach a tag to the instrument, giving name, address and trouble experienced. Pack in a rugged container, preferably wood, using at least three inches of shredded newspaper or excelsior on all sides. Do not ship in the original kit carton as this carton is not considered adequate for safe shipment of the completed instrument. Ship by prepaid express, if possible. Return shipment will be made by express collect. Note that a carrier cannot be held liable for damages in transit if **PACKING IN HIS OPINION** is insufficient.

Prices are subject to change without notice. The Heath Company reserves the right to change the design of this instrument without incurring liability for equipment previously supplied.

RF TEST PROBE KIT

A test probe in kit form for use in measuring RF voltages of up to about 20 Volts is available for \$5.50. The kit contains all parts necessary for the construction of the probe, including 1N34 crystal detector, condensers, resistor, cable and connectors. This probe and cable is simply plugged into the instrument in place of the regular DC test probe assembly and the voltage is read on the lower regular DC ranges.

Order No. 309 RF Test Probe Kit—\$5.50

TELEVISION TEST PROBE KIT

A 30,000 volt test probe in kit form for use in testing the high DC voltage in Television receivers is available for \$5.50. The kit contains all parts necessary for the construction of the probe, such as precision multiplier of 2% accuracy, molded red body and black handle, connectors and cable. This probe and cable is simply plugged into the instrument in place of the regular DC test probe and the range setting of the VTVM is multiplied by 100. Voltages in excess of 30,000 V DC should not be taken.

Order No. 336 TV High Voltage Probe Kit—\$5.50

PEAK-TO-PEAK PROBE

A probe kit for measuring peak-to-peak voltages is available for \$6.50. Use of the probe permits reading peak-to-peak voltages directly on the VTVM calibrated scales. Probe operates in a range of 5 kc to 5 MC and consists of probe housing, two crystal diodes, condensers, shield lead and plug.

Order No. 338 Peak-to-Peak Voltage Probe—\$6.50.

WARRANTY

The Heath Company limits its warranty of any parts supplied with any Heathkit (except tubes, meters and rectifiers, where the original manufacturer's guarantee only applies) to the replacement within three (3) months of said part, which when returned with prior permission, postpaid, was, in the judgment of the Heath Company, defective at the time of sale.

The assembler is urged to follow the instructions exactly as provided. The Heath Company assumes no responsibility or liability for any damages or injuries sustained in the assembly of the device or in the operation of the completed instrument.

HEATH COMPANY
Benton Harbor, Michigan

WIRING OF EXPORT TYPE 110/220 VOLT POWER TRANSFORMERS

These transformers have a dual primary for use on either 110 Volts or 220 Volts. Wire as shown.

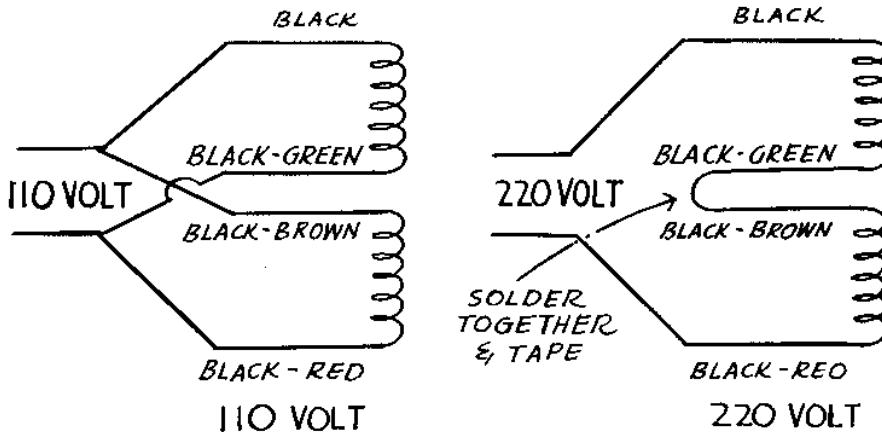

V-6 VACUUM TUBE VOLTMETER PARTS LIST.

Part No.	Parts Per Kit	Description	Part No.	Parts Per Kit	Description
Resistors			Sockets--Terminal Strips--Jacks--Fiber Washers		
2-48	1	9.2 Ohm Precision	434-16	1	Miniature Socket (9 pin)
2-24	1	90 Ohm Precision	434-25	1	Octal Socket
2-29	1	900 Ohm Precision	434-22	1	Pilot Light Socket
2-35	1	9K Ohm Precision	252-12	1	Pilot Light Nut
2-50	1	10K Ohm Precision	455-1	1	Pilot Light Bushing
2-38	1	20K Ohm Precision	413-1	1	Pilot Light Jewel
2-9	1	70K Ohm Precision	431-1	1	1 Lug Terminal Strip
2-41	1	90K Ohm Precision	431-3	1	3 Lug Terminal Strip
2-54	1	200K Ohm Precision	436-3	1	Banana Jack (Red)
2-13	1	700K Ohm Precision	436-2	1	Banana Jack (Black)
2-51	1	900K Ohm Precision	437-1	2	Banana Jack Inserts
2-55	1	2 Megohm Precision	436-1	1	Phone Jack
2-16	1	7 Megohm Precision	253-2	1	$\frac{1}{4}$ Fiber Shoulder Washer #6
2-22A	1	9 Megohm Precision	253-1	1	9/64 Plain Fiber Washer
1-21	1	15K	Hardware		
1-22	1	22K	250-4	2	4-40 x $\frac{1}{4}$ Screws
1-25	1	47K	252-2	2	4-40 Nuts
1-35	2	1 Megohm	250-2	2	3-48 x $\frac{1}{4}$ Screws
1-38	1	3.3 Megohm	252-1	2	3-48 Nuts
1-42A	1	5.6 Megohm	250-9	9	6-32 x 3/8 Screws
1-40	1	10 Megohm	250-26	1	6-32 x $\frac{1}{2}$ Binder Head Screw
Condensers			250-8	2	#6 x 3/8 Sheet Metal Screws
20-8	1	.003 MFD	250-19	2	10-24 x 3/8 Handle Screws
23-5	1	.01 MFD 2000 Volt	250-22	2	Pointer Knob Set Screws
25-5	1	16 MFD 150 Volt	250-30	2	Banana Plug Screws
Controls			252-3	10	6-32 Nuts
10-9	2	10K Ohms (AC & DC Calibrate)	252-7	8	Control Nuts
10-8	2	10K Ohms (Ohms & Zero Adjust)	254-1	13	#6 Lockwashers
10-28	1	7.5 Megohm (AC balance)	254-4	8	Control Lockwashers
Switches			253-10	5	Control Nickel Washers
63-18	1	Selector	252-9	2	Speednuts for Jacks
63-42	1	Range	259-1	2	Solder Lugs
60-1	1	SPST Slide	73-1	3	3/8 Grommets
Tubes--Lamp			261-1	4	Rubber Feet
411-33	1	6H6 Tube	208-2	1	Battery Spring Clip
411-25	1	12AU7 Tube	260-4	1	Battery Base Clip
412-1	1	#47 Pilot Lamp	204-M36	1	Battery Mtg. Z Angle Bracket
Wire--Plugs--Prods			204-M33	1	L Chassis Bracket
344-1	1	Roll Hookup Wire	260-1	1	Alligator Clip
346-1	1	Length Spaghetti	Miscellaneous		
341-2	1	Length Red Test Lead 3 Ft.	462-4	2	Acorn Knobs
341-1	1	Length Black Test Lead 3 Ft.	462-M11	2	Pointer Knobs
343-1	1	Length Shielded Test Lead 3 Ft.	407-16	1	200 Microamp Meter.
89-1	1	Line Cord	418-1	1	Flashlight Cell (Calibrated)
438-M8	2	Sleeve and Plug Assemblies	57-1	1	Selenium Rectifier
70-3	1	Red Banana Plug Insulator Sleeve	54-2	1	Power Transf mer
70-2	1	Black Banana Plug Insul. Sleeve	200-M32	1	Chassis
438-3	1	Phone Plug	211-1	1	Handle
439-1	1	Red Test Prod	203-3F1	1	Front Panel
439-2	1	Black Test Prod	90-17	1	Cabinet and Rear Cover
			595-40	1	V-6 Manual

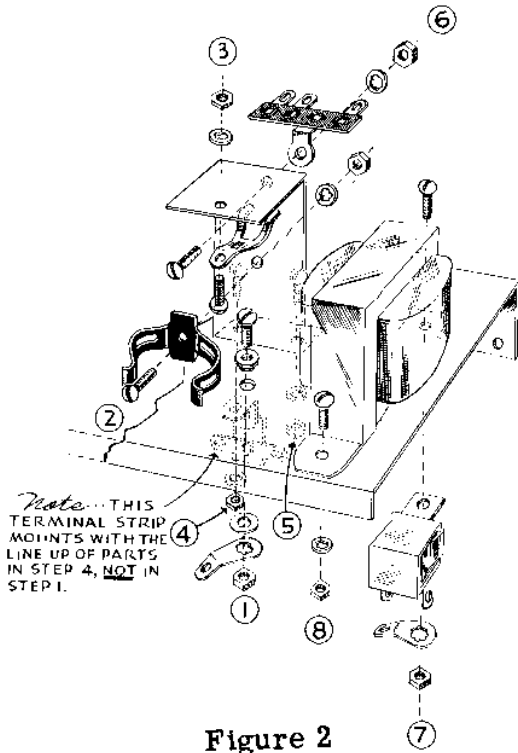

Figure 2

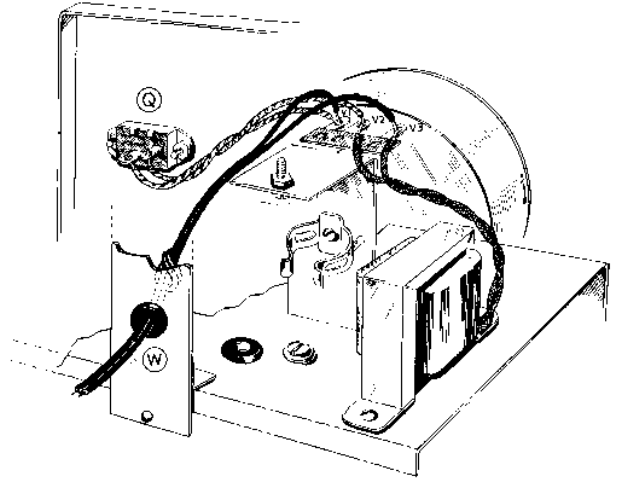
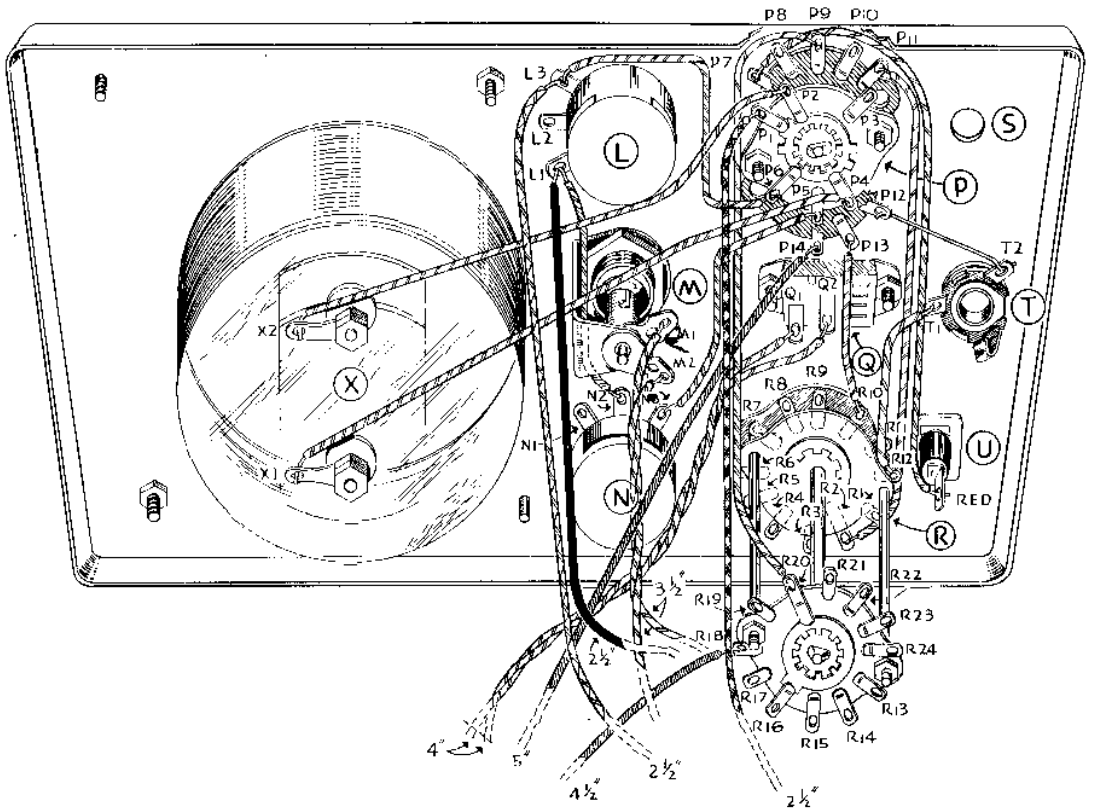
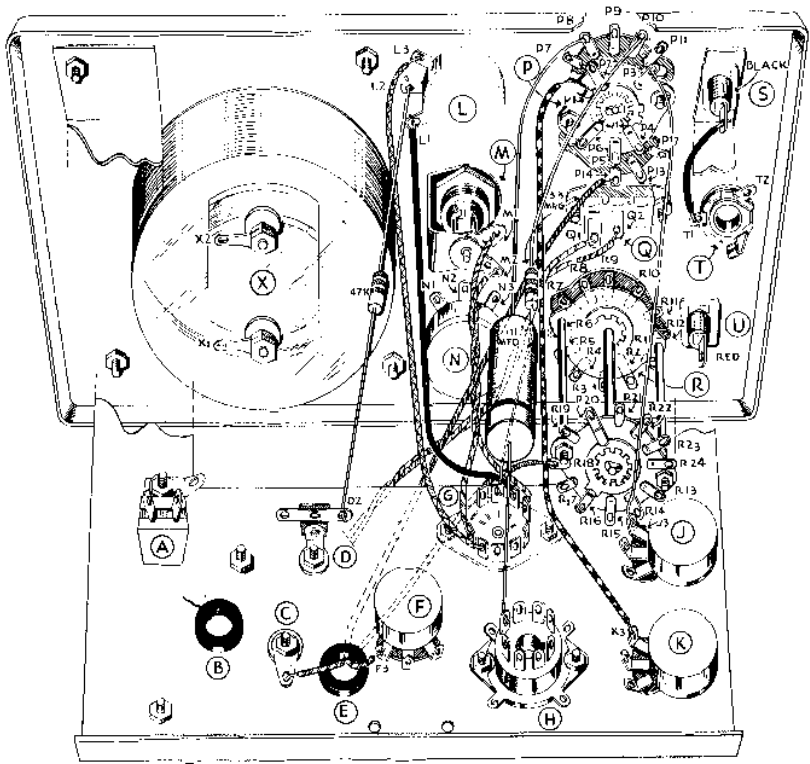

Figure 12



Pictorial 2 Wiring of Panel



Pictorial 3 Starred (*) Steps Apply-Wiring Common to Both Chassis and Panel

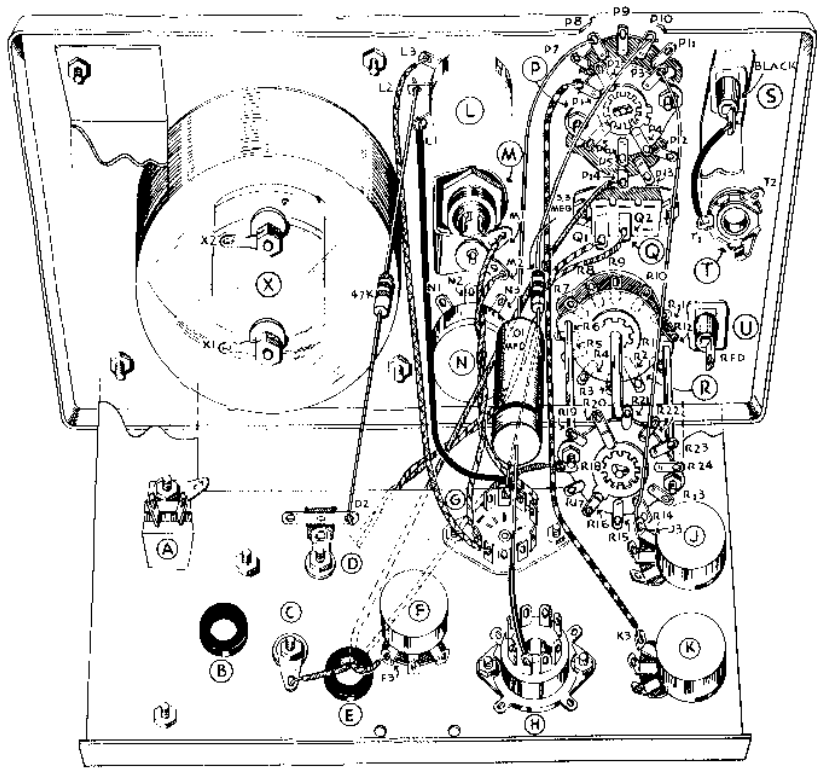

Pictorial 3 Reversed Diodes-Wiring Common to Both Chassis and Panel

HELPFUL KIT BUILDING INFORMATION

Before attempting actual kit construction read the construction manual through thoroughly to familiarize yourself with the general procedure. Note the relative location of pictorials and pictorial inserts in respect to the progress of the assembly procedure outlined.

This information is offered primarily for the convenience of novice kit builders and will be of definite assistance to those lacking thorough knowledge of good construction practices. Even the advanced electronics enthusiast may benefit by a brief review of this material before proceeding with kit construction. In the majority of cases, failure to observe basic instruction fundamentals is responsible for inability to obtain desired level of performance.

RECOMMENDED TOOLS

The successful construction of Heathkits does not require the use of specialized equipment and only basic tools are required. A good quality electric soldering iron is essential. The preferred size would be a 100 watt iron with a small tip. The use of long nose pliers and diagonal or side cutting pliers is recommended. A small screw driver will prove adequate and several additional assorted screw drivers will be helpful. Be sure to obtain a good supply of rosin core type radio solder. Never use separate fluxes, paste or acid solder in electronic work.

ASSEMBLY

In the actual mechanical assembly of components to the chassis and panel, it is important that the procedure shown in the manual be carefully followed. Make sure that tube sockets are properly mounted in respect to keyway or pin numbering location. The same applies to transformer mountings so that the correct transformer color coded wires will be available at the proper chassis opening.

Make it a standard practice to use lock washers under all 6-32 and 8-32 nuts. The only exception being in the use of solder lugs—the necessary locking feature is already incorporated in the design of the solder lugs. A control lock washer should always be used between the control and the chassis to prevent undesirable rotation in the panel. To improve instrument appearance and to prevent possible panel warping use a control flat nickel washer under each control nut.

When installing binding posts that require the use of fiber insulating washers, it is good practice to slip the shoulder washer over the binding post mounting stud before installing the mounting stud in the panel hole provided. Next, install a flat fiber washer and a solder lug under the mounting nut. Be sure that the shoulder washer is properly centered in the panel to prevent possible shorting of the binding post.

WIRING

When following wiring procedure make the leads as short and direct as possible. In filament wiring requiring the use of a twisted pair of wires allow sufficient slack in the wiring that will permit the twisted pair to be pushed against the chassis as closely as possible thereby affording relative isolation from adjacent parts and wiring.



























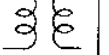
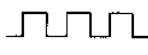





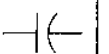
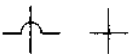

When removing insulation from the end of hookup wire, it is seldom necessary to expose more than a quarter inch of the wire. Excessive insulation removal may cause a short circuit condition in respect to nearby wiring or terminals. In some instances, transformer leads of solid copper will have a brown baked enamel coating. After the transformer leads have been trimmed to a suitable length, it is necessary to scrape the enamel coating in order to expose the bright copper wire before making a terminal or soldered connection.

In mounting parts such as resistors or condensers, trim off all excess lead lengths so that the parts may be installed in a direct point-to-point manner. When necessary use spaghetti or insulated sleeving over exposed wires that might short to nearby wiring.

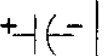
It is ingeniously recommended that the wiring dress and parts layout as shown in the construction manual be faithfully followed. In every instance, the desirability of this arrangement was carefully determined through the construction of a series of laboratory models.

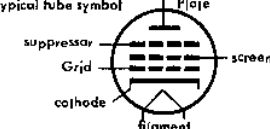
SOLDERING

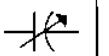
Much of the performance of the kit instrument, particularly in respect to accuracy and stability, depends upon the degree of workmanship used in making soldered connections. Proper soldered connections are not at all difficult to make but it would be inadvisable to observe a few precautions. First of all before a connection is to be soldered, the contact itself should be clean and mechanically strong. Do not depend on solder alone to hold a connection together. The tip of the soldering iron should be bright, clean and free of excess solder. Use enough heat to thoroughly flow the solder smoothly into the joint. Avoid excessive use of solder and do not allow a flux flooding condition to occur which could conceivably cause a leakage path between adjacent terminals on switch assemblies and tube sockets. This is particularly important in instruments such as the VTVM, oscilloscope and generator kits. Excessive heat will also burn or damage the insulating material used in the manufacture of switch assemblies. Be sure to use only good quality rosin core radio type solder.

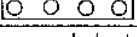
Antenna General		Resistor General		Neon Bulb		Receptacle two conductor	
Loop		Resistor Tapped		Illuminating Lamp		Battery	
Ground		Resistor Variable		Switch Single pole Single throw		Fuse	
Inductor General		Potentiometer		Switch double pole single throw		Piezoelectric Crystal	
Air core Transformer General		Thermistor		Switch Triple pole Double throw		1000 =	K
Adjustable Powdered Iron Core		Jack two conductor		Switch Multipoint or Rotary		1,000,000 =	M
Magnetic Core Variable Coupling		Jack three conductor		Speaker		OHM =	Ω
Iron Core Transformer		Wires connected		Rectifier		Microfarad =	MF
Capacitor General		Wires Crossing but not connected		Microphone		Micro Microfarad =	MMF
Capacitor Electrolytic		A. Ammeter V. Voltmeter		Typical tube symbol 	Binding post		
Capacitor Variable		G. Galvanometer MA. Milliammeter uA. Microammeter, etc.			Terminal strip		
						Wiring between like letters is understood	$\begin{matrix} \downarrow & \downarrow & \downarrow \\ X & Y & X \\ \rightarrow & \rightarrow & \rightarrow \\ Y & X & Y \end{matrix}$

HEATH COMPANY
BENTON HARBOR, MICHIGAN

THE WORLD'S
Finest
TEST EQUIPMENT
IN KIT FORM