

RADIO'S LIVEST MAGAZINE



June 34
25 Cents
Canada 30¢

Radio-Craft

HUGO GERNSBACK Editor

MORT VROOMAN

RADIO-EQUIPPED
POLICEMEN

See Page 720

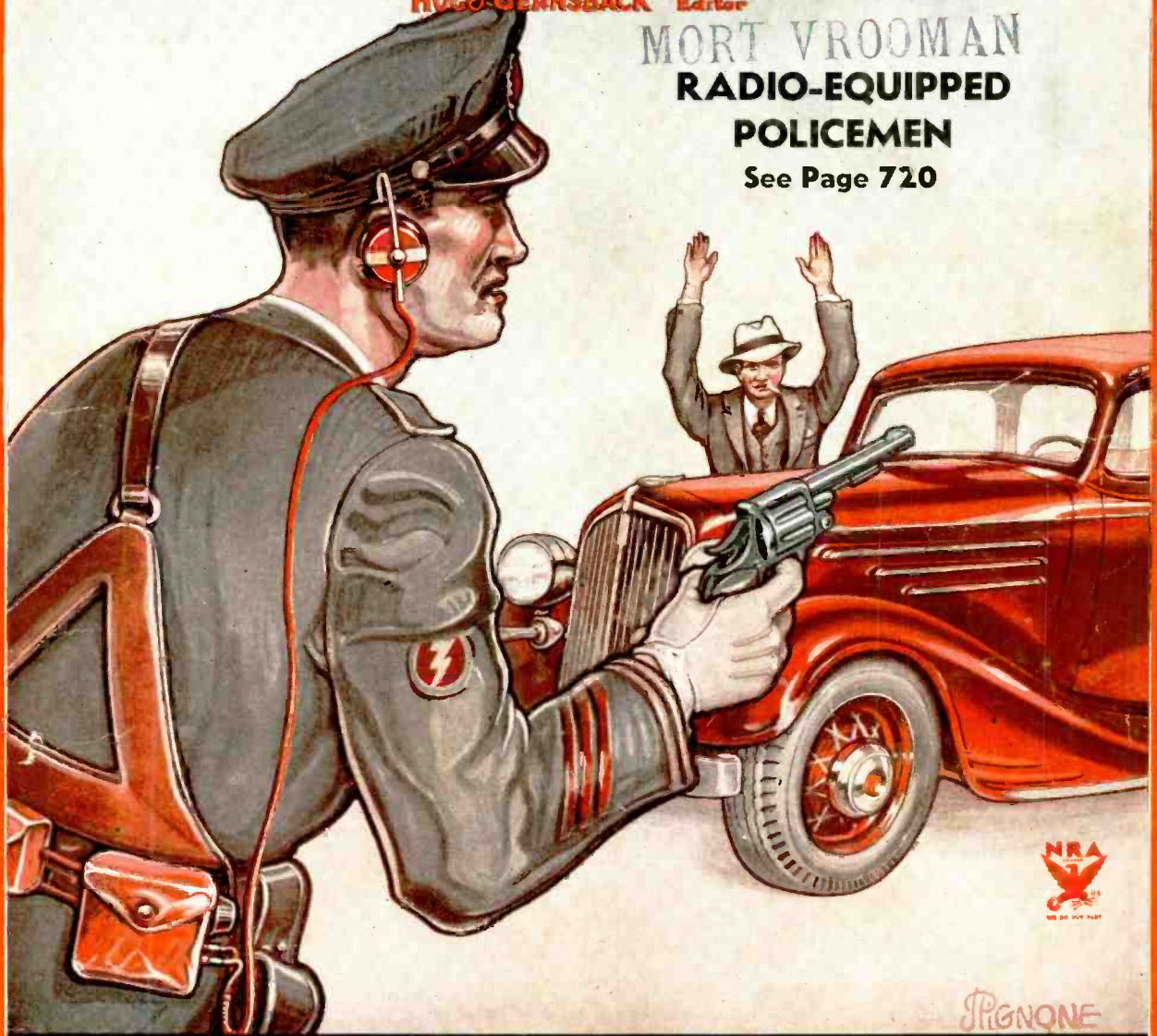

IGNONE

Broadcast Station List — Amplified Chimes — 6 Tube Battery Portable
The Radiovota — All-Electric 1 Tube Set — Automatic Program Censor

ANNOUNCING

A GOLDEN OPPORTUNITY FOR ALERT RADIO MEN IN THE NEXT GREAT INDUSTRY

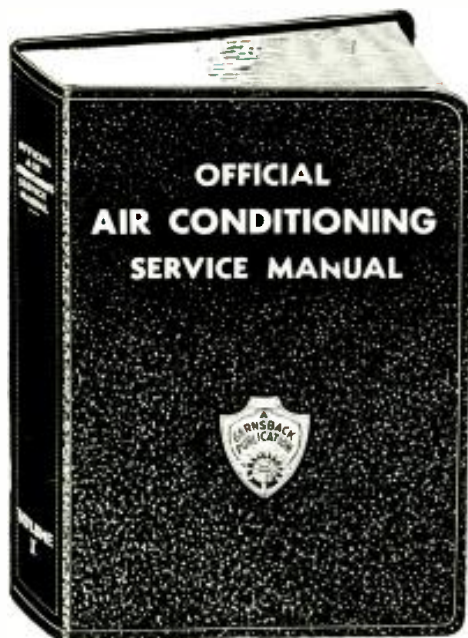

PRE-
PUBLICATION
OFFER

\$4.00

THE idea of electricians, radio service men and other mechanically inclined men, servicing Air Conditioning and Refrigeration Units is self-evident and the thought has occurred to some untold thousands ever since air conditioning equipment has been installed in public auditoriums, theatres, studios, department stores, office buildings and manufacturing plants. The tremendously broad possibilities in this new industry are bound to give employment and success to men far-sighted enough to see its advancement and development. We quote an excerpt from Mr. Hugo Gernsback's editorial which appeared in the September, 1933 issue of *Everyday Science and Mechanics*:

"I advise young and progressive men to go into the air-conditioning business during the next few years, because, this, without a doubt, is the coming industry in this country. Thousands of small firms will spring up, undertaking to air-condition private houses, small business offices, factories, etc. We are not going to tear down every building in the United States immediately. It will be a gradual growth; yet small installation firms will air-condition small houses, and even single offices in small buildings."

This is only partial proof of the certain success of this new field. Further assurance is that engineering schools have already added many important courses on air conditioning to their regular curriculum. Architects and building contractors are giving considerable thought to installation of this equipment in structures which are now being planned and built. The beginning of this business will probably be similar to the auto and radio industry, but in a few short years it will surpass these two great fields.

Official Air Conditioning Service Manual

352 Pages
Over 600 Illustrations
9" x 12" in Size
Flexible, Loose Leaf
Leatherette Cover



MAIL COUPON TODAY!

GERNSBACK PUBLICATIONS

Dept. RC-634

96-98 Park Place, New York, N. Y.

Gentlemen: Enclosed you will find my remittance of Two Dollars for which you are to send me One Copy of the OFFICIAL AIR CONDITIONING SERVICE MANUAL, postage prepaid, as soon as it comes off the press. I am to pay the additional Two Dollars to postman when it is delivered. It is understood that the regular price of the book will be FIVE DOLLARS when it comes off the press, and I am now paying only a pre-publication price of Four Dollars.

Name

Address

City State

(Send remittance in form of check, money order or unused U.S. Postage Stamps. Register letter if it contains stamps or currency.)

THE OFFICIAL AIR CONDITIONING SERVICE MANUAL is being edited by L. K. Wright, who is an expert and a leading authority on air conditioning and refrigeration. He is a member of the American Society of Refrigerating Engineers, American Society of Mechanical Engineers, National Association of Practical Refrigerating Engineers; also author of the OFFICIAL REFRIGERATION SERVICE MANUAL and other volumes.

In this Air Conditioning Service Manual nearly every page will be illustrated; every modern installation and individual part carefully explained; diagrams furnished of all known equipment; special care given to the servicing and installation end. The tools needed will be illustrated and explained; there will be plenty of charts and page after page of service data.

Remember there is a big opportunity in this new field and plenty of money to be made in the servicing end. There are thousands of firms selling installations and parts every day and this equipment must be cared for frequently. Eventually air conditioning systems will be as common as radios and refrigerators in homes, offices and industrial plants. Why not start now—increase your earnings with a full- or spare-time service business.

You have the opportunity to get your copy of the OFFICIAL AIR CONDITIONING SERVICE MANUAL today—at a saving of ONE DOLLAR. When the book comes off press, which will be June 15th, the price will be \$5.00 a copy. YOUR ORDER TODAY BRINGS YOU A COPY FOR \$4.00. POSTAGE PREPAID. This is our usual courtesy, pre-publication offer which enables us to determine the approximate print order for the first press run. Send us the coupon today, together with a deposit of \$2.00. When the book reaches you, you pay the other \$2.00.

Here are some of the chapter heads of the AIR CONDITIONING SERVICE MANUAL:

Contents in Brief

History of Air Conditioning; Fundamental Laws; Methods of Refrigeration; Ejector System of Refrigeration; Compression System of Refrigeration; Refrigerants; Lubricating Oils; Liquid Throttle Devices; Servicing Expansion and Float Valves; Servicing Refrigerating Systems; Control Devices; Thermodynamics of Air Conditioning; Weather in the United States; The Field of Air Conditioning; Insulating Materials; Heat Transmission Through Walls; Complete Air Conditioning Systems; Estimating Requirements for the Home, Small Store, Restaurant; Layout of Duct Systems; Starting Up a System; Operating and Servicing Air Conditioning Systems; Air Filtration, Ventilating and Noise Eliminating Devices; Portable Electric Humidifiers and Room Coolers; Automatic Humidifiers; Air Conditioning Units for Radiator Systems and Warm Air Systems; Central Conditioning Units, etc.

GERNSBACK PUBLICATIONS, INC.
96-98 Park Place New York, N. Y.

OPPORTUNITIES

are many

for the Radio Trained Man



Don't spend your life slaving away in some dull, hopeless job! Don't be satisfied to work for a mere \$20 or \$30 a week. Let me show you how to get your start in Radio — the fastest-growing, biggest money-making game on earth.

Jobs Leading to Salaries of \$50 a Week and Up
Prepare for jobs as Designer, Inspector and Tester—as Radio Salesman and in Service and Installation Work—as Operator or Manager of a Broadcasting Station—as Wireless Operator on a Ship or Airplane, or in Talking Picture or Sound Work—HUNDREDS OF OPPORTUNITIES for a real future in Radio!

Ten Weeks of Shop Training

Pay Your Tuition After Graduation

We don't teach by book study. We train you on a great outlay of Radio, Television and Sound equipment—on scores of modern Radio Receivers, huge Broadcasting equipment, the very latest and newest Television apparatus, Talking Picture and Sound Reproduction equipment, Code Practice equipment, etc. You don't need advanced education or previous experience. We give you — **RIGHT HERE IN THE COYNE SHOPS** — the actual practice and experience you'll need for your start in this great field. And because we cut out all useless theory and only give that which is necessary you get a practical training in 10 weeks.

TELEVISION *and* TALKING PICTURES

And Television is already here! Soon there'll be a demand for THOUSANDS of TELEVISION EXPERTS! The man who learns Television now can have a great future in this great new field. Get in on the ground-floor of this amazing new Radio development! Come to COYNE and learn Television on the very latest, newest Television equipment. Talking Picture and Public Address Systems offer opportunities to the Trained Radio Man. Here is a great new Radio field just beginning to grow! Prepare NOW for these wonderful opportunities! Learn Radio Sound Work at COYNE on actual Talking Picture and Sound Reproduction equipment.

PAY FOR YOUR TRAINING

After You Graduate

I am making an offer that no other school has dared to do. I'll take you here in my shops and give you this training and you pay your tuition after you have graduated. Two months after you complete my course you make your first payment, and then you have ten months to complete your payments. There are no strings to this offer. I know a lot of honest fellows haven't got a lot of money these days, but still want to prepare themselves for a real job so they won't have to worry about hard times or lay offs.

I've got enough confidence in these fellows and in my training to give them the training they need and pay me back after they have their training.

If you who read this advertisement are really interested in your future here is the chance of a life time. Mail the coupon today and I'll give you all the facts.

ALL PRACTICAL WORK

At COYNE in Chicago

ALL ACTUAL, PRACTICAL WORK. You build radio sets, install and service them. You actually operate great Broadcasting equipment. You construct Television Receiving Sets and actually transmit your own Television programs over our mod-

ern Television equipment. You work on real Talking Picture machines and Sound equipment. You learn Wireless Operating on actual Code Practice apparatus. We don't waste time on useless theory. We give you the practical training you'll need—in 10 short, pleasant weeks.

MANY EARN WHILE LEARNING

You get Free Employment Service for Life. And don't let lack of money stop you. Many of our students make all or a good part of their living expenses while going to school and if you should need this help just write to me. Coyne is 33 years old. Coyne Training is tested—proven beyond all doubt. You can find out everything absolutely free. Just mail coupon for my big free book!

H. C. Lewis, Pres. RADIO DIVISION Founded 1899
COYNE ELECTRICAL SCHOOL

500 S. Paulina St., Dept. A4-8H Chicago, Ill.

Mail Coupon Today for All the Facts

H. C. LEWIS, President

Radio Division, Coyne Electrical School

500 S. Paulina St., Dept. A4-8H Chicago, Ill.

Dear Mr. Lewis:—Send me your Big Free Radio Book, and all details of your Special Offer, including your "Pay After Graduate" offer.

Name

Address

City..... State.....



HUGO GERNSBACK, Editor-in-Chief

J. T. BERNSELY, Managing Editor

C. W. PALMER
Associate Editor

R. D. WASHBURNE
Technical Editor



CONTENTS OF THE JUNE, 1934, ISSUE

VOLUME V

Number 12

Editorial: Radio Noises.....	Hugo Gernsback	709
The Radio Month in Review.....		710
Radio Pictorial		712
International Radio Review.....		714
The Latest Radio Equipment.....		716
Amplified Chimes for Schools — Churches.....	J. T. Bernsley	718
Radio-Equipped Policemen.....	R. D. Washburne	720
The Radiovota.....	C. W. Palmer	721
Broadcast Station List.....		722
Uplifting the Service Profession.....	F. E. Colt	725
A "Super" Battery Portable.....	A. M. Wengel	726
Ultra-Portable P.A. Systems.....	L. Littmann	728
The Relative Merits of Class A, A Prime and Class B Audio Amplifier Circuits.....	M. A. Apstein	728
An Automatic Program Censor.....	S. R. Winters	729
A Beginners' "All-Electric" 1 Tube Set.....	F. R. Harris	730
Operating Notes		731
Short-Cuts in Radio.....		732
11 Tube Super Broadcast Receiver.....		734
A 3 Tube A.C.-D.C. All-Wave Portable.....	Herman Cosman	734
The "Uni-Shielded" Short-Wave Three.....		735
A Short-Wave Booster.....		735
RADIO-CRAFT'S Information Bureau.....		736
Readers' Department		737
RADIO SERVICE DATA SHEETS:		
No. 115—Zenith Challenger Model 740 10 Tube Battery-Operated Superheterodyne		738
No. 116—Clarion 5 Tube Model 423; 6 Tube 470, 471 and 472; and 10 Tube 480		740

IN OUR NEXT FEW ISSUES:

AUTO RADIO RECEIVERS. Due to the tremendous increase this year in interest and sales of auto radio receivers, RADIO-CRAFT will devote a considerable number of pages to this subject in the July issue. Some very new and interesting designs are being released for this season. These features, which will appeal to many Service and Installation Men, will be described.

A SENSITIVITY SET TESTER. A very novel Service Man's unit for determining the overall efficiency (amplification) of a receiver after repairs are made. In addition to this, the unit will permit comparing receivers, checking tubes, aligning T.R.F. and I.F. stages, and locating inoperative R.F. stages. Its construction and operation are exceedingly simple, and its use will enable the Service Man to raise his standard of service.

RADIO-CRAFT is published monthly, on the fifth of the month preceding that of date; its subscription price is \$2.50 per year. (In Canada and foreign countries, \$3.00 a year to cover additional postage.) Entered at the post office at Mt. Morris, Ill., as second-class matter under the act of March 3, 1879.

Text and illustrations of this magazine are copyright and must not be reproduced without permission of the copyright owners. We are also agents for WONDER STORIES and EVERYDAY SCIENCE AND MECHANICS. Subscription to these magazines may be taken in combination with RADIO-CRAFT at reduced Club rates. Write for information.

Copyright 1934. Continental Publications, Inc.

HUGO GERNSBACK, President

I. S. MANHEIMER, Secretary

Published by Continental Publications, Inc. Publication office: 404 N. Wesley Ave., Mount Morris, Illinois. Editorial and Advertising Office: 96-98 Park Place, New York City. Chicago Advertising Office: L. F. McClure, 919 North Michigan Avenue, Chicago, Ill. Western Advertising Office: Loyd B. Chappell, 511 So. Alexandria St., Los Angeles, Calif.

London Agent: Hachette & Cie., 3 La Belle Sauvage, Ludgate Hill, E.C. 4
Paris Agent: Hachette & Cie., 111 Rue Reamur
Australian Agent: McGills Agency
179 Elizabeth St., Melbourne



I WILL HELP YOU START A SPARE TIME OR FULL TIME RADIO SERVICE BUSINESS WITHOUT CAPITAL

**HERE ARE A FEW EXAMPLES
OF THE KIND OF MONEY
I TRAIN MY MEN TO MAKE**

Clears \$4500 in 18 months

"Before taking your Radio Course I was making \$18 a week. I came here three years ago and in the past months I made about \$4500 in Radio. I cannot say too much for the wonderful help I have received from N. R. I."

NOEL W. RAY,

American National Bank Bldg.
Gadsden, Alabama.



**Spare Time Work Pays
\$18 a Week**

"I only do spare time Radio work and average \$18 a week. People who in good times would buy a new Radio, now have the old one fixed."

STEPHEN J. DRAPCHATY,
407 Wunderlich Avenue,
Barberton, Ohio.



Now Owns Own Business

"If I had not taken your Course I would be digging ditches instead of running my own business. One week I made \$75 on repairing alone, and this doesn't count sales. If a fellow wants to get into Radio, N. R. I. is the starting point."

R. S. LEWIS,
Modern Radio Service,
Pittsfield, Ill.



**SPECIAL Radio Equipment
for Broad Practical Experience
Given Without Extra Charge**

My Course is not all theory. I'll show you how to use my special Radio equipment for conducting experiments and building circuits which illustrate important principles used in such well-known sets as Westinghouse, General Electric, Philco, R.C.A., Victor, Majestic, and others. You work out with your own hands many of the things you read in our lesson books. This 50-50 method of training makes learning at home easy, interesting, fascinating, intensely practical. You learn how sets work, why they work, how to make them work.



**Free Book Tells How
Mail Coupon!**

The world-wide use of Radio sets for home entertainment has made many opportunities for you to have a spare time or full time Radio business of your own. I give you instructions early in your Course for doing 28 Radio jobs common in almost every neighborhood. Many N. R. I. men make \$5, \$10, \$15 a week extra in spare time almost at once. I show you how to install and service all types of receiving sets. I give you Radio equipment and instructions for conducting experiments, for building circuits and testing equipment, and for making tests that will give you broad, practical Radio experience. Clip the coupon below and get my free 64-page book, "Rich Rewards in Radio"—it gives you a full story of the success of N. R. I. students and graduates, and tells how to start a spare time or full time Radio business on money made in spare time while learning.

**Many N. R. I. Men Make \$5,
\$10, \$15 a Week Extra in
Spare Time Almost at Once**

Many of the seventeen million sets now in use are only 25 per cent to 40 per cent efficient. I will show you how to cash in on this condition. I will show you the plans and ideas that have enabled many others to make \$5, \$10, \$15 a week in spare time while learning. Ford R. Leary, 1633 Davison Road, Flint, Mich., wrote: "My part-time earnings while taking the N. R. I. Course were \$651."

**Get Ready Now for a Radio
Business of Your Own and
for Jobs Like These**

Broadcasting stations use engineers, operators, station managers, and pay up to \$5,000 a year. Radio manufacturers use testers, inspectors, foremen, engineers, servicemen and buyers, and pay up to \$7,500 a year. Radio dealers and jobbers employ hundreds of servicemen, salesmen, managers, and pay up to \$5,000 a year. Radio operators on ships enjoy life, see the world, with board and lodging free, and get good pay besides. My book tells you of the opportunities in Radio, Set Servicing, Aircraft Radio, Television, Police Radio, Short Wave, and other fields. Get it.

FREE Radio Servicing Tips

Let me PROVE that my Course is clear, easy to understand and fascinating to study. Send the coupon for a free lesson, "Trouble Shooting in D.C., A.C., and Battery Sets."

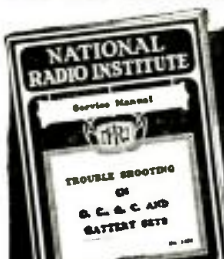

This interesting lesson gives 132 ways to correct common Radio troubles. I am willing to send this book to prove that you too can master Radio—just as thousands of other fellows have done. Many of them, without even a grammar school education, and no Radio or technical experience, have become Radio experts and now earn two or three times their former pay. Mail the coupon now.

**I Will Train You at Home
in Your Spare Time**

Hold your job until you're ready for another. Give me only part of your spare time. You do not need a high school or college education. Hundreds with only a common school education have won bigger pay through N. R. I. J. A. Vaughn jumped from \$35 to \$100 a week. J. E. McLaurine increased his earnings 100 per cent. The National Radio Institute is the Pioneer and World's Largest organization devoted exclusively to training men and young men by Home Study for good jobs in the Radio industry.

You Must Be Satisfied

I will give you an agreement to refund every penny of your money if you are not satisfied with my Lesson and Instruction Service when you complete my Training. And I'll not only give you thorough training in Radio principles, practical experience in building and servicing sets, but also Advanced Training in any one of five leading branches of Radio opportunities.

Free Book of Facts

Mail the coupon for "Rich Rewards in Radio." It's free to any ambitious fellow over 15 years old. It tells you about Radio's spare time and full time opportunities; about my training; what others who have taken it are doing and making. Mail coupon now—in an envelope or paste on a 1c post card.

*Get
my new book
It points out
what Radio
Offers You*



**J. E. SMITH, Pres.
Dept. 4FX,
National Radio
Institute,
Washington, D. C.**

**This Coupon is Good For One
FREE COPY OF MY NEW BOOK**

J. E. SMITH, President,
National Radio Institute,
Dept. 4FX,
Washington, D. C.



Dear Mr. Smith: I want to take advantage of your Special Offer. Send me your two books, "Trouble Shooting in D.C., A.C. and Battery Sets" and "Rich Rewards in Radio." I understand this request does not obligate me. (Please print plainly.)

Name Age.....
Address
City State M

Find out about the World Famous Course that Pays for Itself

Radio Men!

**HERE ARE GOOD BOOKS
COVERING EVERY BRANCH OF RADIO**

Presented on this page are the books of the RADIO-CRAFT LIBRARY—the most complete and authentic set of volumes treating individually, important divisions of radio. Each book has been designed to give radio men the opportunity to specialize in one or more of the popular branches of the industry. You will find them a real help in your work and they will contribute to your money earning capacity. Read these books during your spare time at home.

The authors of these books are well-known to everybody. Each one is an expert radio man; an authority on the subject—each is thoroughly familiar with the field which he represents.

This is the first real opportunity that you have ever had to build a radio library of books that are authentic. **MOST OF THE BOOKS HAVE BEEN REVISED AND REWRITTEN TO KEEP THEM UP TO THE MINUTE.** Mail coupon below for your books.

Book No. 1
Radio Set Analyzers
And How To Use Them
By L. VAN DER MEL

With Full Instructions and Descriptions of Set Analyzers, Tube Checkers, Oscillators, Etc.

Book No. 2
Modern Vacuum Tubes
And How They Work
By ROBERT HERTZBERG

With complete Technical Data on All Standard and Many Special Tubes.

Book No. 3
The Superheterodyne Book

All About Superheterodynes
By CLYDE FITCH
How They Work, How to Build and How to Service Them.

Book No. 4
Modern Radio Hook-Ups
The Best Radio Circuits
By R. D. WASHBURNE

A Complete Compendium of the Most Important Experimental and Custom-built Receivers.

Book No. 5
How to Become a Radio Service Man

By LOUIS MARTIN
How to get started in the business of servicing radios and how to make money in this field.

Book No. 6
Bringing Electric Sets Up to Date
By CLIFFORD E. DENTON

With Pentodes, Multi-Mus, Dynamic Speakers—Complete Information How to Modernize A. C., D. C. and Battery Operated Receivers.

Book No. 7
Radio Kinks and Wrinkles
By C. W. PALMER

For Service Men and Experimenters
A Complete Compendium on the Latest Radio Short-Cuts and Money Savers—These Kinks Are Great Time-Savers.

Book No. 8
Radio Questions and Answers
By R. D. WASHBURNE

A Selection of the Most Important of 5,000 Questions Submitted by Radio Men During the Course of One Year—They Are All Answered by a Technical Expert.

Book No. 9
Automobile Radio and Servicing
By LOUIS MARTIN

A Complete Treatise on the Subject Covering All Phases from Installing to Servicing and Maintenance. A Book That is Greatly Needed Today.

Book No. 10
Home Recording and All About It
By GEORGE J. SALIBA

A Complete Treatise on Instantaneous Recordings, Microphones, Recorders, Amplifiers, Commercial Machines, Servicing, etc.

Book No. 11
Point-to-Point Resistance Measurements
By CLIFFORD E. DENTON

The Modern Method of Servicing Radio Receivers—a Book Which All Radio Men Have Referred to More Than Any Other.

Big Discount To You

In order to make it possible for everyone to buy these books, the fifty (50) cent price has been made uniform for all volumes. You can buy these books separately, but you should take advantage of our special offer.

When Five (5) Books Or More Are Ordered Deduct 20% From Your Remittance

Simply fill in the coupon at left, and mail it to us together with your remittance. Checks, stamps or money orders accepted.

Here are the subjects covered--

- Set Analyzers
- Tubes
- Superheterodyne Circuits
- Radio Hook-ups
- Servicing Business
- Modernizing Electric Sets
- Kinks and Wrinkles
- Questions and Answers
- Auto-Radio Servicing
- Home Recording
- Resistance Measurements
- Public Address

All Books Uniform The books in the new RADIO-CRAFT LIBRARY are all strictly up-to-date, and written by men who know their subjects. The volumes are all uniform size, 6x9 inches, and contain on an average of 50 to 120 illustrations. Each book is printed on fine book paper and no expense has been spared to make it an outstanding value, for its editorial contents as well as from the mechanical standpoint.



CLIP—MAIL THIS COUPON TODAY!

GERNSBACK PUBLICATIONS, INC., 96-98 Park Place, New York, N. Y.

I have circled below the numbers of books in the RADIO-CRAFT LIBRARY, which you are to send me, and have deducted 20% for ordering five (5) books or more. I have included my remittance in full, at the price of 50c each, when less than five books are ordered.

The amount of my remittance is..... (Stamps, checks or money orders accepted.)

Circle numbers wanted: 1 2 3 4 5 6 7 8 9 10 11

Name Address

City State RC-434



"Takes the Resistance Out of Radio"

Editorial Offices: 96-98 Park Place, New York, N. Y.

HUGO GERNSBACK, Editor

Vol. V., No. 12, June, 1934

RADIO NOISES

An Editorial by HUGO GERNSBACK

WHEN radio broadcasting first got into its stride in the early '20's, many complaints were heard about radio noises—that is, natural, as well as man-made static—which kept annoying listeners all over the world. The reason for these early complaints was found in the low power of the broadcast stations, which was of the order of 500 watts, seldom going as high as 1,000 watts. Since the signal intensity of the broadcast emitters was low, and the static intensity often high, the static noises were sufficient to blot out radio reception; and frequently nothing at all could be heard, except noise.

Radio engineers soon came to realize that they were up against a difficult job in attempting to eliminate static; so they turned their efforts toward increasing the power of the broadcast stations, and they have been at this ever since. Gradually, stations became more and more powerful until, now, the signal level is so high that, in nearly all cases, natural and man-made static can easily be drowned out by the powerful broadcast signals. There are exceptions to this rule; as, for instance, natural static during nearby thunderstorms, or when some especially noisy electrical appliance located in the same building or in the same apartment is operated. In these cases, both kinds of static are strong enough and cause sufficient interference with the radio signal to make ordinary listening difficult. But nowadays—let us say in 80 to 90 per cent. of day or night reception—radio noises are not continuously bad enough to mar a program.

Then too, the art has advanced until we have better filtering systems, and better shielding of both the radio set and aerial system; so that, at least for broadcast reception, it may be said that radio noises, except for unusual situations, are not now anywhere near as troublesome as they were five or ten years ago. Indeed, as times advances, and radio technique improves, new methods are found to kill that arch enemy of radio, static. And, though no practical static eliminator has, as yet, been invented, I confidently look forward to the time when, as regards broadcast reception, static, except during the midst of a thunderstorm, will be a thing of the past.

The situation is totally different when we leave the broadcast band and go down into the short-wave spectrum. At the present time, the condition prevails, with practically all short-wave radio sets, particularly in the larger centers, that reception, from 200 meters down, becomes more and more difficult, the further down you go in wavelength. Particularly is this true in the waveband between 10 and 30 meters, where the noise level today is of such height that most short-wave programs are utterly ruined by static—almost exclusively man-made, except where electrical storms are local.

Now that all-wave radio sets are coming into vogue, the radio set manufacturers are doing themselves great harm by not informing the public of the noise element. The public is told by beautiful advertisements, and otherwise, that sta-

tions from the Antipodes can be brought in at will. This is true enough, but the advertisements and the salesmen who sell the sets *say nothing about the all-pervading noise*. This is a pity, because if the customer were forewarned that nothing has, as yet, been invented to kill all the noises, he would not blame the set, as he is apt to do now.

The technical reason, why there is more noise on the short waves than on the broadcast waves, is simple. Most of the electrical appliances, and particularly automobile ignition systems themselves, send out short waves and, because regulation short-wave sets must be more sensitive as a rule than broadcast sets, and as the circuit of the short-wave end of an all-wave set is more sensitive, it is easy to see why there is much more interference in the short-wave band than in the broadcast band.

While some advance has been made during the past few years in noise elimination for short-wave reception, an enormous amount of work remains to be done. It is true that, in order to eliminate the extraneous noise, it is first necessary to shield the radio set far better than we have been accustomed to do. It is also true, that the aerial system for short-wave reception must be of a totally different kind from that for broadcast reception, at least, at this stage of the art. Some advance has been made through the use of the so-called transposition type of aerial lead-in; but, though it cuts down the noise level to some extent, this probably is not the final solution of the problem. Of course, it should be understood that, when we receive a station five or ten thousand miles away, the incoming energy is only the smallest fraction of that received from a local broadcast station. Naturally, therefore, when the signal intensity is so small and the static level is so high, we are right back where we were in the early '20's; that is, the static disturbance overrides the incoming signal, and all we get is noise. It is too much to hope that a station at the Antipodes will lay down a signal at your receiving set as powerful as that of a broadcast station ten miles distant from you. So, for some years to come, the hope that the received power of distant stations will be sufficient to override the noise level seems hopeless. Therefore, an entirely new technique must be built up to filter out or tune out the unwanted noise; and, while this remedy may amount to static elimination, I prefer to believe that the solution is not impossible.

I am certain that there are some electrical means whereby the unwanted noises can be tuned out or filtered out, or a combination of both may be adapted. I personally believe that it is not a question of aerials at all, and that the final solution will be in the set itself! It probably will be accomplished by the means of a vacuum tube, or a similar instrumentality.

Radio noise elimination is a fascinating subject; it shows that radio is still in its infancy, and that we have much as yet to learn.

THE RADIO MONTH

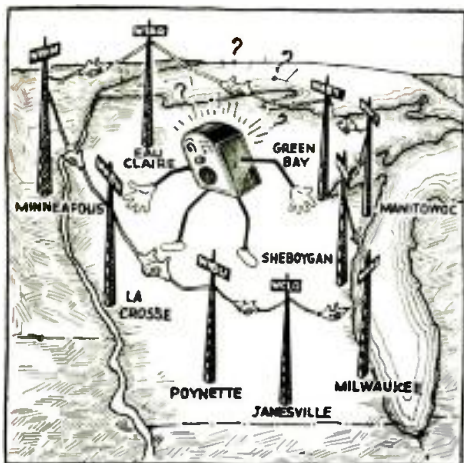

ONE OF THE NEW NETWORKS
The poor radio listener will soon have difficulty in escaping the network octopus.

NEW RADIO CHAINS IN THE MAKING

SINCE our first announcement of the influx of rumors and confirmed reports of new broadcast chains (RADIO-CRAFT, February, 1934, pg. 454) several developments have taken place.

Last month, a new group which had been working so quietly that even rumors did not "seep out", started a chain covering five mid-west states centering around Wisconsin with nine stations. This group named itself the North American Broadcasting System and at present is so arranged that the programs can originate from any one of the 9 stations.

These stations are as follows:

- WCLO—Janesville, Wis. . . 100 W.
- WHAD—Milwaukee, Wis. . . 250 W.
- WHBL—Sheboygan, Wis. . . 500 W.
- WHBY—Green Bay, Wis. . . 100 W.
- WIBU—Poynette, Wis. . . 100 W.
- WKBH—La Crosse, Wis. . . 100 W.
- WOMT—Manitowoc, Wis. . . 100 W.
- WRHM—Minneapolis, Minn. 1000 W.
- WTAQ—Eau Claire, Wis. . 1000 W.

At the same time, the soft-pedalled McClelland chain (RADIO-CRAFT, February 1934, pg. 454) has apparently moved to the West Coast, where it is rumored that the headquarters will be set up under the supervision of a leading motion picture producer. According to its originator, plump-faced George F. McClelland, operation will not be hurried and no attempt will be made to swing the group into action until every detail has been completed.

And still another group of stations has started to band together and share

programs with the object of ultimately forming an extensive chain. This comprises the WOR (Newark), WGN (Chicago) and WLW (Cincinnati) network. These stations are among the few large stations in the country not firmly attached to either of the two big chains.

Thus, the present chain situation, as it now exists, is—of the 600 stations in the U. S., 170 are included in the National or Columbia Networks. But the large majority of the remaining stations are low in power, have limited hours for operation and operate on wavelengths well into the "graveyard" end of the band.



MAJ.-GEN. GEORGE OWEN SQUIER
Inventor of wired-wireless, who died of pneumonia last month.

IN MEMORIAM OF MAJOR-GENERAL GEORGE O. SQUIER

LAST month, one of radio's most colorful radio pioneers, Major-General George Owen Squier, passed away, of an attack of pneumonia. He was 69 years old, and was retired from the Signal Corps in 1924.

General Squier's radio developments date away back to 1904 when he published his famous paper on the absorption of electromagnetic waves by living vegetable organisms and showed how trees could be used for the reception of radio messages.

Possibly his greatest invention was "wired-wireless", that system of communicating over commercial wires by

the use of radio waves. This invention is still commercially practical and is, in fact, used in a modified form in transmitting many of the telegraph and cable messages across the country or under the Atlantic, and also for "Carrier-Current Telephony."

The sharp-eyed Major-General was a graduate of West Point, and served as Chief Signal Officer during the World War. He was the recipient of many military honors and medals and had won both the Elliott Cresson and the Franklin medals for his electrical research work.

OUSTING RADIO PIRATES

YOU "can't" win—is a term often heard when the long arm of John Law is being discussed, and this seems to apply particularly well where radio pirating—that is, the operation of a radio station without a license—is concerned.

Last month, two young radio fans, in Norwich, England, conceived the brilliant idea of "radio-ing" to each other. And so great was their enthusiasm that they completely ignored the formality of obtaining a license. They rigged up two phone transmitters, tuned by the way to 279 meters (well into the broadcast band), and started to talk to each other—and then, to the world at large.

The B.B.C. stations which supply Great Britain with all of its radio entertainment have a silent period every Sunday morning, presumably to permit the radio audience to go to church. During this time, Wilfred and Gerald Barker started out, full blast, to send



A 4 WATT PIRATE
The English station that caused the British Post Office so much trouble.

IN REVIEW

Radio is now such a vast and diversified art it becomes necessary to make a general survey of important monthly developments. RADIO-CRAFT analyzes these developments and presents a review of those items which interest all.

phonograph music, weather reports and re-transmissions of the Continental broadcasters, much to the gratification of the English radio audience and the chagrin of the British Post Office, which controls broadcasting in that country. As a matter of fact this honorable department was so deeply hurt at this "slight" that they sent out a special radio patrol car to find the interlopers, which they succeeded in doing one Sunday morning. Subsequently, they confiscated the offending 4 watt station and extracted a profuse apology from the brothers Barker, as well as a small fine.

On this side of the Atlantic, during the past month, a much more vicious pirate has been causing the Federal Radio Commission no end of trouble. This much publicized individual is Dr. John Richard (Goat Gland) Brinkley, whose station in Milford, Kansas had been ordered off the air some time ago. Whereupon, the estimable and astute Doc. Brinkley immediately crossed the Mexican border and opened up with a super-power station which caused constant interference with stations in the U. S.

Finally one day last month a Mexican radio inspector with a body-guard of troopers stormed the Villa Acuna station XER and put it off the air for good.

Persistent Doc. Brinkley has now purchased a 150 ft. yacht which it is reported he is fitting up with a powerful station to broadcast from the high seas!

We don't know whether to conclude that "radio advertising" helps sell Goat Gland medicine, or perhaps Goat Gland medicine enables one to defy federal law and build broadcast stations (which, incidentally, cost a pretty penny).



YO-HO-HO AND A (50 KW.) BOTTLE OF—
Doc. Brinkley of XER fame has threatened to broadcast from the high seas.

ONCE AGAIN THE RADIO SHOW

RADIO enthusiasts within traveling distance of New York will be glad to hear that during last month plans were definitely started for the second annual combined National Electrical and Radio Exposition at Madison Square Garden. According to the announcement made by busy Ralph Neumuller, managing director of the Electrical Association of New York, this show of shows will start Wednesday, Sept. 19 and continue for 11 days through Saturday, Sept. 29, 1934.

Readers of this page will remember that after the show last year, we pointed out that although visitors were inclined to fall over refrigerators, and other electrical "what-nots," here, there and everywhere, the show was none the less a great success for radio fans.

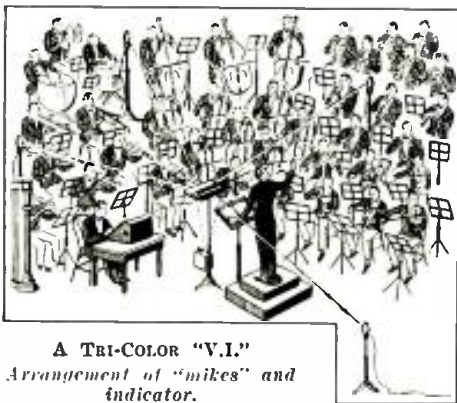

A TRI-COLOR "V.I."
Arrangement of "mikes" and indicator.

ORCHESTRA VOLUME INDICATOR

LAST month, experimental work was completed on a new electronic beam instrument for showing visually the sound intensity of an orchestra, and which has been designed especially for lean, wiry Leopold Stokowski, famed maestro of the Philadelphia Orchestra. The instrument, which was developed by Ivan Eremeeff, Russian inventor and experimenter and John G. Leitch, technical supervisor of WCAU, is now being used by Conductor Stokowski in conducting the Philadelphia Orchestra concerts over the coast to coast network of the Columbia Broadcasting System.

The visual indicator consists of a



LEOPOLD STOKOWSKI
Using the visual indicator to help in conducting the Philadelphia Orchestra.

specially constructed galvanometer, carrying a very light shutter which interrupts a light beam, and projects it by means of an optical system on a 30 inch glass screen, placed immediately before Mr. Stokowski.

Light of three colors is projected on the glass scale, the colors representing sound of low, medium and high intensity. This is in order that the conductor may at a glance determine the approximate position of the music in the dynamic range. Often times, the approximate level of the orchestra is all that the conductor wishes to know throughout the somewhat extended musical passages. This may be easily determined by the colored light without the conductor's attention being distracted from his score, which is preferable to observing the exact numerical level on a calibrated scale.

During rehearsal prior to the broadcast, Mr. Stokowski and the control engineer determine the peak levels of each composition and set the gain control at a fixed point. With the visual indicator placed in front of the conductor, he is able to control the volume of the orchestra according to the visual color indication on the instrument and it is not necessary for the engineer to change the fixed level. This gives complete control of the rendition to the conductor, instead of entrusting it to the engineer who may be a top-notch technician, but is certainly not a musician or conductor.

RADIO'S NEW POLICE WORK

POLICE radio has been afforded much publicity during the past year. The agile "Radio" (Continued on page 747)

RADIO PICTORAL

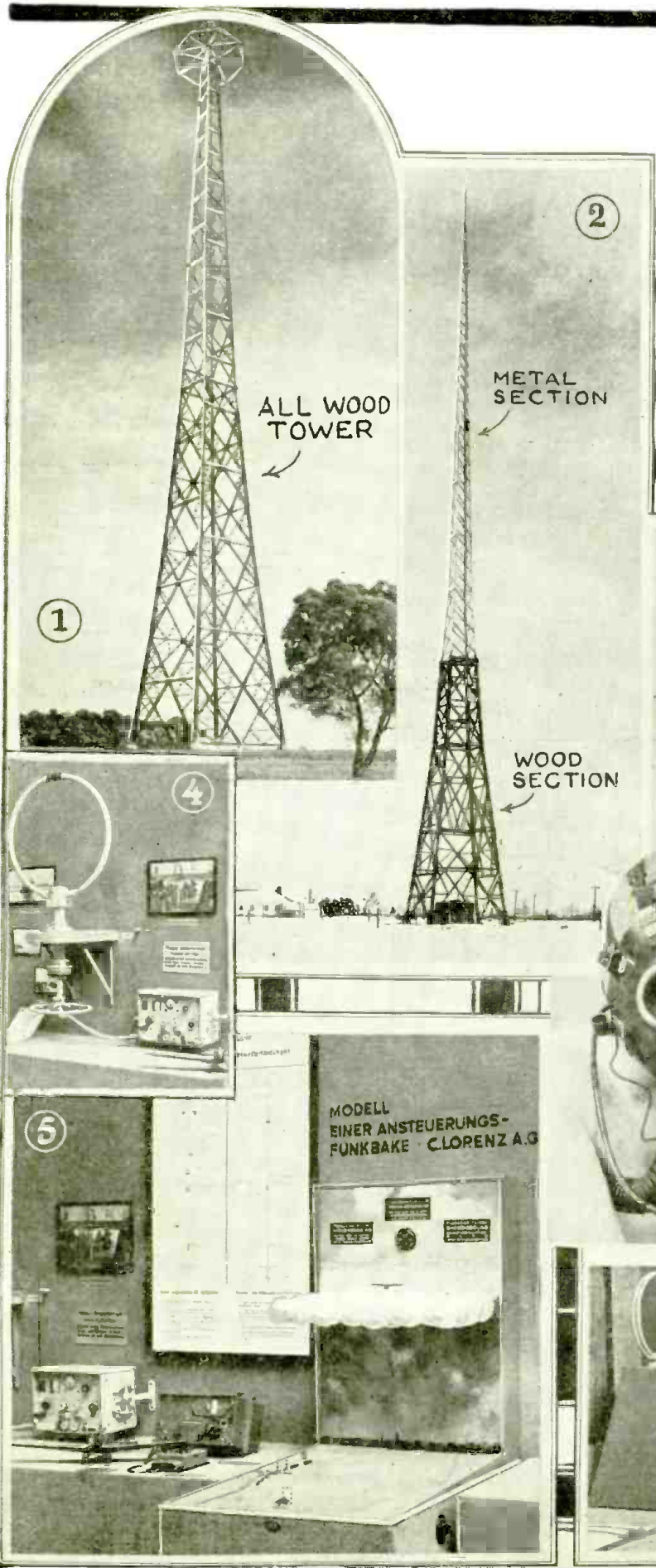

MOST of us are familiar with the half-wave aerial, described in the November, 1931, issue of RADIO-CRAFT. Recently, several improvements have been made in this type of radiator. At 1 is shown the aerial tower of the broadcast station in Breslau, Germany. The tower is wooden and the aerial consists of a bronze cable suspended vertically through the center of the tower. As the cable is not $\frac{1}{2}$ wavelength in height, a bronze ring supported at the top of the mast provides a terminal capacity to raise the effective wavelength. By limiting the vertical radiation by the use of this construction, fading effects are said to be reduced considerably. At 2 is shown an American half-wave aerial, used at station WEBC at Superior, Wisconsin. By raising the half-wave steel portion of the aerial on a section of wood tower, the radiation of the station has been increased appreciably. At 3 is a view of the apparatus with which Captain C. B. Scully intends to broadcast from the bottom of New York harbor, as soon as weather permits. At 4 is a German goniometer or direction finder; at 5 is a landing beam model which supplies a continuous signal when the plane is on the beam and interrupted signals when it deviates; at 6 is a remotely operated direction finder.

Photo courtesies: 1, Telefunken; 2, Broadcast News; 3, NBC; 4, 5, 6, Kappelmayr.

THE mailman for Little America is shown at 7. Messages from friends and relatives of the members of the Byrd Expedition are read every two weeks from short-wave station W2XAF at Schenectady, N. Y. Employing a directional aerial, the station is a real post office of the air, as reliable contact is maintained at all times. At 9 are shown two workers in an English radio laboratory installing tiny radio receivers in the hats of the London "Bobbies." The sets are said to have a receiving range of over 100 miles. Scotland Yard has at last found a practical use for those 5 gallon helmets. The photo at 9 shows a Massachusetts engineer, Robert H. Packard with a model yacht which he has equipped for radio control. A small receiver and a group of selector switches, relays and gears are mounted in the hull of the boat. A small portable transmitter, operating at 80 meters controls the boat. At 10 is shown a view of a "Cosmic Ray Hodoscope." This instrument consists of a large number of cylindrical counters stacked in a two dimensional bank or screen. Each of the individual counters in the bank is connected through one stage of amplification to a neon glow lamp. The discharge of a counter initiated by an ionizing ray, thus produces a flash in the corresponding lamp and a motion picture camera focussed on the neon tubes records the individual flashes. The Hodoscope therefore accomplishes the same purpose as the Wilson Cloud Chamber (RADIO-CRAFT, March 1934, p. 519) but it has the advantage of being continuously sensitive. At 11 is shown one of the Department of Commerce radio beacon stations which will keep all fliers in constant touch with the position of the Macon during her proposed tours, to prevent possible accidents.

Photo courtesies: 7, General Electric; 8, Press Photos; 9, Boston Herald; 10, 11, Dept. of Commerce.

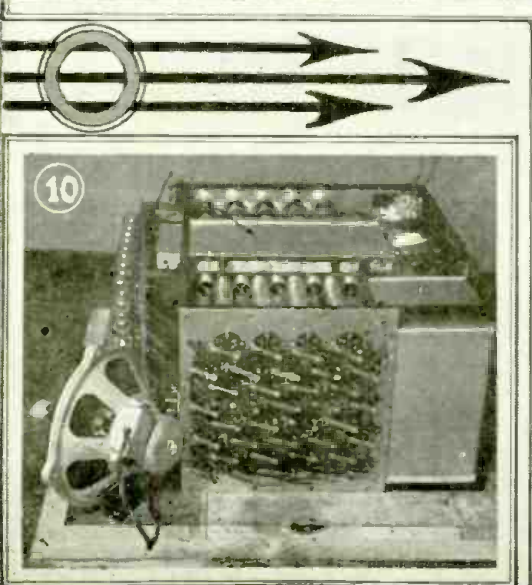

INTERNATIONAL RADIO REVIEW

REAL VERNIER ACTION

HOW many times have you experimenters, especially if you are interested in short waves, wished that you had a *real* vernier dial? One that would give smooth action and an extremely high ratio of motion.

An English designer, in a recent issue of *AMATEUR WIRELESS* magazine described a unit that should be the answer to all short-wave experimenters' prayers. It is made from parts taken from a small clock, as shown in the three illustrations, Figs. 1, 2 and A.

By means of the two hands of the clock, we are able to divide one revolution of the hour hand (12 hours) into 720 parts (minutes) and to read off any one part with the greatest of ease.

By arranging the tuning condensers to be rotated from minimum to maximum while the hour hand moves around the dial from 12 o'clock to 12 o'clock (360 degrees), and reading off as for the time in hours and minutes we have in effect, with a 4 in. diameter dial, a scale length of no less than 12 ft. The 100 broadcast-station channels are, therefore, an average of nearly $1\frac{1}{2}$ in. apart and come in at about 7 minute intervals.

In the practical construction of the dial, the controlling knob is connected to a spindle in the center of the dial and this spindle is geared, by means of the usual 12-to-1 clock wheels, to a sleeve which fits around it and carries the hour hand.

It is necessary for the hour hand to make a complete revolution while the tuning device, which is usually a bank of condensers, moves from maximum to minimum. A 2-to-1 gear is, therefore,

HERE is what the radio experimenter has been wanting for a long time—a semi-technical review of the thousands of new ideas which are continually appearing in overseas publications. Each month there are received at the offices of *RADIO-CRAFT* hundreds of daily, weekly and monthly magazines originating from every point on the face of the globe.

SINCE the cost of subscribing to each of these would be prohibitive for most radio men, we have arranged with technical translators to prepare for our readers reviews of all the really important, new developments illustrated and described each month in these international radio periodicals.

NOTE that the only available information is that which is published; the experimenter must adapt the ideas to whatever equipment he has on hand.

provided between the hour hand sleeve and the condenser shaft coupling, so that we have a 24-to-1 gearing between this and the control knob.

The minute hand will, of course, move with the center spindle and the knob, but unfortunately there is a certain amount of backlash, due to play between the teeth of the gears. With the friction

drives usually employed this is avoided, but there is always a risk of a slipping taking place and since an indicating hand is used on each gear, to avoid this trouble a positive drive should be used to keep them in step.

The effect of backlash is noticed when reversing the direction of tuning, the center spindle revolves a small amount before the condenser shaft commences to move; consequently, if the minute hand were fixed directly to the spindle, the readings when moving up would be a little higher than when tuning down. With good gears, the backlash will be quite small.

In any case, the trouble is quite simple to overcome. Instead of fixing the minute hand to the spindle it is counter-balanced and loosely pivoted on the hour hand collar. A small forked piece, shown in Fig. 2, is fixed to the spindle and this moves the hand, so that on reversing the direction of rotation the hand remains stationary while the spindle rotates a small predetermined amount to take up the backlash.

The dial itself is marked as an ordinary clock face and can be illuminated from the front or behind in the usual way. In addition to the clock markings, it can have wavelengths (or better still, kilocycles) indicated at the point of the hour hand and also, if desired, the station call letters.

Owing to the 2-to-1 gear, the shaft of the condenser rotates in the opposite direction to the hands and the dial should be connected to the appropriate end of the condenser shaft.

In Fig. 1 is shown the diagram of the gears used in the dial. The figures

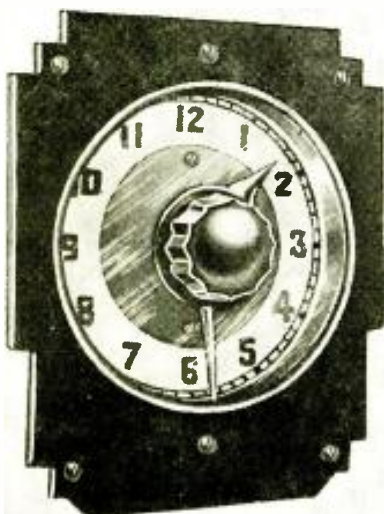

A double-calibrated super vernier dial.

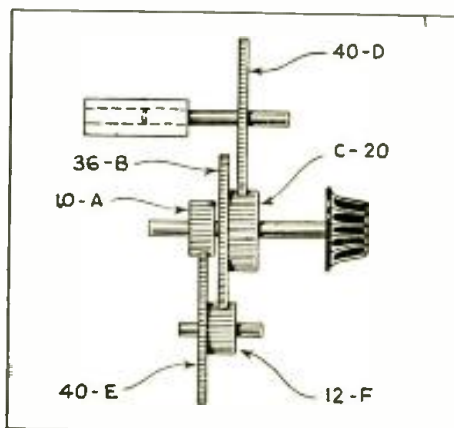
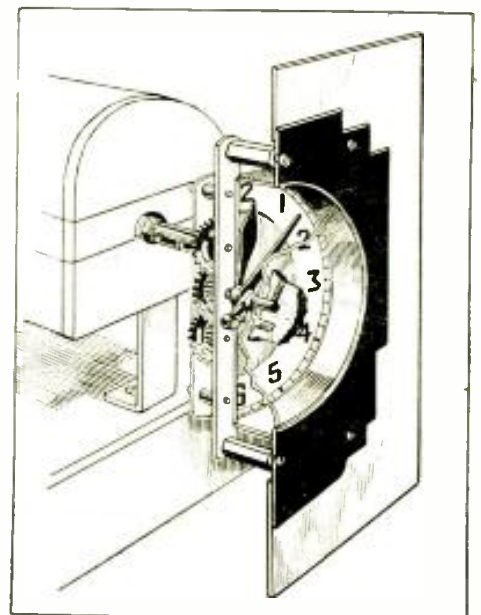

Fig. A, left
The appearance of the new clock vernier dial.

Fig. 1, above
The numbers indicate the teeth in the gears.

Fig. 2, right
The assembly of the dial to the receiver.



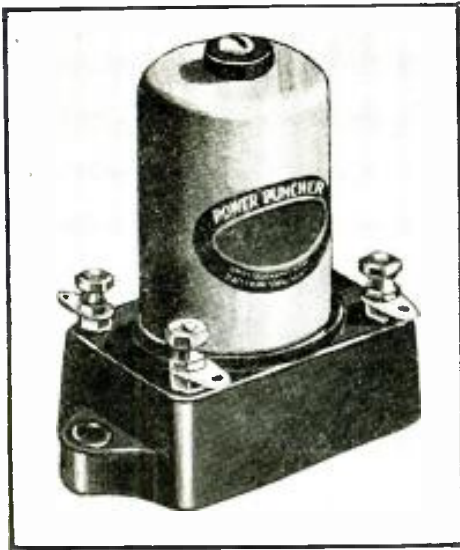

Fig. B
The Power Puncher "B" battery economizer.

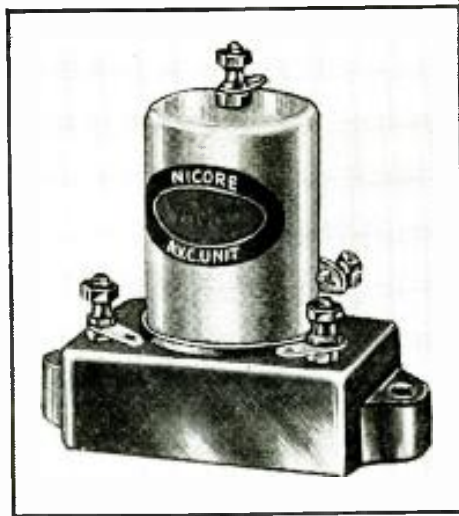
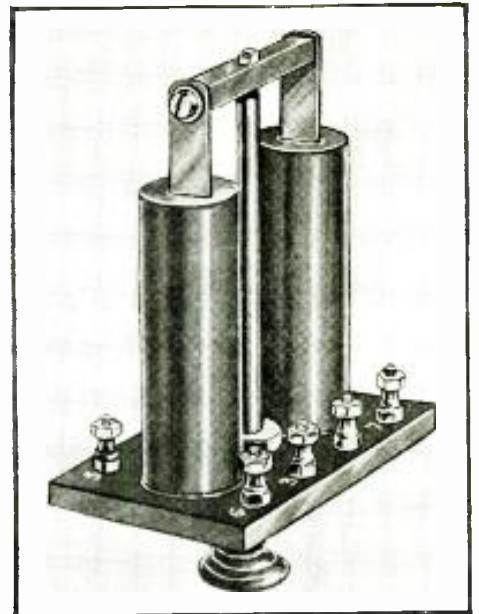

Fig. C, above
A metal-oxide rectifier for A.V.C.
Fig. F, right
The Bifocal movable core tuning coil.



indicate the number of teeth on each of the gears. Of the gear wheels, A is secured to the knob spindle carrying the minute hand. Gears B and C are fixed together and are free on the knob spindle carrying the hour hand; E and F are fixed together and act as intermediate pinions. The drive is via A, E, F, B, C to D.

The actual construction of the dial can possibly be improved, by using a drive knob below the dial, connected in the usual way with a cord and pulley or other mechanical arrangement.

TUBE-LESS A.V.C.

WHILE recent set designs in this country have been toward more and more tubes, as shown by the 14, 16 and even 18 tube sets that have been advertised, our more conservative cousins in Europe have been making attempts to reduce the number of tubes to a minimum, while still maintaining the latest in design considerations.

This fact is brought out clearly in the two devices shown in Figs. B and C. The first, at B, is called the "Power Puncher."

It combines a "B" current economizing unit with a device for boosting the output of a set, without increasing the number of tubes.

In this unit, part of the A.F. output from the power tube is rectified by a small metal-oxide rectifier and a portion of the D.C. voltage so obtained is applied in series with a fixed bias to the output tube. Initially, the output tube is over-biased, thus reducing the plate current. The additional bias obtained from the "power puncher" opposes the fixed bias, thus reducing the bias voltage when a signal is applied, which in turn increases the plate current to its normal value. This unit produces a material saving in "B" batteries for portable and other battery operated sets.

The second and probably more interesting unit is a tube-less A.V.C. unit. This device replaces the usual detector plate bypass condenser in the set. In the unit is a small metal rectifier which converts the R.F. component of the detector plate current into D.C., which is fed back through one of several possible circuit arrangements to the grid circuits of the R.F. or I.F. tubes, thus pro-

ducing A.V.C. or delayed A.V.C. actions. The amount of A.V.C. depends of course on the amount of amplification preceding the detector tube. In the delayed control circuits, the delay voltage is obtained from the bias voltage of one of the succeeding (A.F.) tubes in the set.

AUTOMATIC PHONOGRAPH ATTACHMENT

IN RECENT issues of WIRELESS WORLD an interesting phono-adaptor has appeared. As shown in Fig. D, it consists of a table which serves the double purpose of containing the phonograph mechanism and supporting table-type sets, a good many of which are being sold in Europe.

An interesting feature of the unit is the drawer opening arrangement which permits the cabinet to be closed while the record is being played. The device is equipped with an automatic stop arrangement which shuts off the motor when the record is finished. An adapter is provided to simplify connections to the amplifier of the radio receiver.

(Continued on page 742)



Fig. D
A combined radio set stand and phonograph.

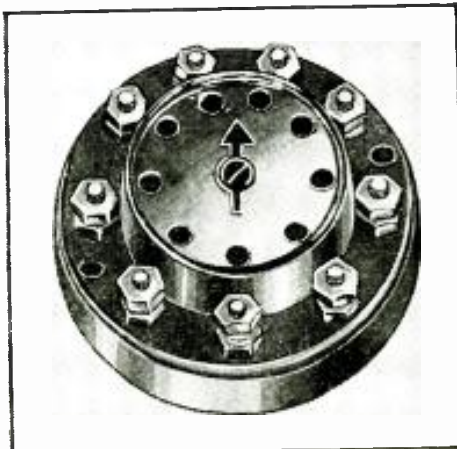

Fig. E
Nine prongs—count 'em. It looks as though European manufacturers have beat us to the development of 8 and 9 prong tubes.

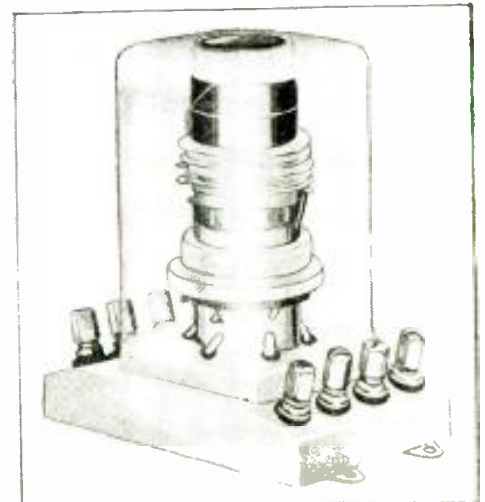
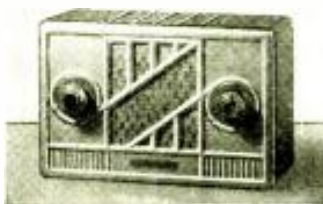

Fig. G
This coil covers 150-550 and 850-1,950 meters.

THE LATEST RADIO EQUIPMENT



Battery ultra-midget. (No. 445)

BATTERY ULTRA-MIDGET (No. 445)

THIS ultra-midget T.R.F. receiver measures only 9 $\frac{3}{4}$ x 6 $\frac{3}{4}$ x 5 $\frac{1}{8}$ ins. deep. The metal cabinet is finished in deep maroon and gold. A magnetic reproducer is used. Sensitivity and volume are good.

It operates on 6 V. "A" and 135 V. "B"; the current drain is very low. The "B" lead is fused.

The following tubes are used: one type 78 R.F. amplifier; one 77 detector; and one 38 A.F. amplifier.



Dynamotor "B." No. 446

DYNAMOTOR "B" (No. 446)

AN ESPECIALLY compact "B" supply unit of the dynamotor type developed for use in airplanes, automobiles, boats, buses, sound trucks, farm lighting plant installations and broadcast stations. Equipped with ball bearings that do not require oiling, these units will operate from 6, 12 or 32 V., D.C., and deliver from 100 to 300 V., D.C.

The standard model illustrated operates from a 6 V. storage battery; it delivers 30 ma. at 180 V., with an "A" drain of only 2 A. This combined generator and motor, complete with filter, weighs only 10 lbs. It measures only 3 $\frac{5}{8}$ x 5 $\frac{3}{4}$ x 5 $\frac{1}{8}$ ins. in length.

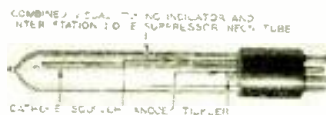

"Q. A. V. C." tuning Tube. (No. 447)

"Q. A. V. C." NEON TUNING TUBE (No. 447)

IN DESIGN, the new neon "tune-a-lite" neon-filled tube for visual indication of resonance; a rising column of light indicates approaching resonance; differs from the standard 3 element type in the addition of a fourth electrode—the "squeeze" electrode in the illustration.

If by increasing the normal discharge current, the cathode discharge is allowed to rise to the level of the fourth electrode, the free ions from the cathode discharge will impinge on the fourth electrode and cause a current to flow in any external circuit connecting the fourth electrode and the cathode, though no external difference of potential be provided.

This current flow in the fourth element circuit jumps from practically zero when the cathode glow is just below the fourth electrode, to a value of about 20 to 100 microamperes when the glow just reaches the level of the fourth electrode.

This new tube permits combined "visual tuning" (as previously), and "interstation noise suppression" ("Q. A. V. C.") in receiver chassis that at present incorporate A. V. C. The tube has an overall length of 4 $\frac{1}{8}$ ins.

MAGNETO-DYNAMIC REPRODUCER (No. 448)

MAGNETO-DYNAMIC reproducers (permanent-magnet "loudspeakers") are fundamentally old; recent developments, however, have greatly improved their efficiency.

The new unit has a highly efficient type of magnet core construction that results in greatly increased flux density; are welding assures mechanical strength, and retention of the magnetism.

A domed center shield, placed in the apex of the cone, effectively prevents dust and magnetic particles from lodging in the air-gap.

"RADIO" REMOTE CONTROL (No. 449)

BY MOUNTING the combined oscillator and first-detector of a superheterodyne on the steering column, the manufacturers eliminate the need for a mechanical coil-spring-type drive shaft for tuning the automotive radio receiver.

The tuner illustrated, which uses a type 6A7 tube, powered from the remote receiver chassis, is designed to match into a chassis having an I.F. of 456 kc.

16 MM. "TALKIES" (No. 450)

PORTABLE sound-on-film equipment has been making rapid strides toward perfection, due to the rapidly increasing demand for equipment of this type.

Some of the improvements incorporated in the unit shown are as follows: 2 case (1 for projector and 1 for amplifier and reproducer); portability; total weight, 55 lbs.; adjustable legs for tilting projector; folding reel arms; ball-bearing reel shafts, with adjustable tension take-up for large reels; biplane concentrated-filament, 750 W. exciter lamp; blower-type ventilating system for keeping exciter lamp cool; 3 claws engage the film; double, pre-focused exciter lamp assembly (for convenient emergency replacement). The output of the standard A.F. amplifier is 7 W. (manufacturer's coverage rating, 1,500 persons).

"OXIDE" P.E. CELL (No. 451)

A DRY-DISC photoelectric cell which converts light energy directly into electrical energy without recourse to batteries or tubes; the output is approximately 5 ma. in direct sunlight.

Especially suitable for use with relays. Case measures 1 x 2 $\frac{1}{2}$ ins. in dia.

SERVICE AIDS (No. 452)

FOUR small but essential aids to speedy servicing are shown; these are products of one manufacturer.

Cement—fast-drying, vibration-proof, flexible and waterproof. Especially suitable for cementing new cones and spiders on dynamic reproducers, cementing rattling cones, loose tube bases and control-grid caps, for sealing adjustments, and for fastening coils into position.

Solvent—for loosening and removing old cement from reproducer cones and spiders; to clean wire-wound volume controls, condenser contacts, etc.; also, this Solvent is a suitable thinner for the Cement.

Speaker Shims—a set of 16 shims, color-coded for the sizes, .004, .006, .008, and .012-in., for quickly obtaining correct alignment of dynamic reproducer voice coils, and magnetic reproducer air-gaps.

Insulating Cloth—a 5,000 V. test cloth for shop use in insulating and preventing grounds on field



"Radio" remote control. (No. 449)

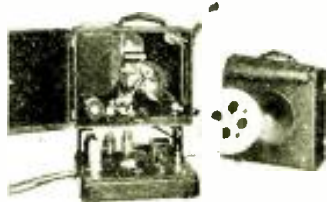

16 mm. "talkies." (No. 450)



"Oxide" P.E. cell. (No. 451)



Service aids. (No. 452)

Name of manufacturer of any device will be sent on receipt of a self-addressed, stamped envelope. Kindly give (number) in description under picture.



1 tube all-wave kit set. (No. 456)

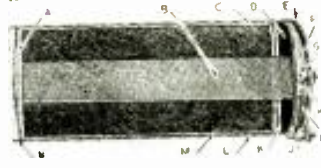

New dry cell. (No. 457)



A stroboscope. (No. 458)

coils, transformers, resistors, condensers, wires, etc. Area of roll, 200 sq. in.

SENDING ANTENNA (No. 453)

A NEW suspension insulator assembly supporting 1/2-in. aluminum 1/4-wave tubes, for efficient matching into a horizontal doublet type antenna, is illustrated. The junction of the 1/4-wave section and the transposed main transmission lines is shown in insert.

3 V. "A" BATTERY (No. 454)

THE 3 V. "A" battery illustrated is not merely a group of No. 6 ("door bell") dry cells connected in series-parallel, for supplying the filament power requirements of "2 V." tubes. Instead, it is made up of two groups of 20, parallel-connected, "B"-size dry cells; the two groups are connected in series.

If the battery is operated at a drain of, for instance, 0.5-A., and a variable resistor is used to maintain the output at 2 V. on the filaments of the tubes, the battery will last approximately 400 hrs., operating 3 hrs. per day.

However, although the total capacity in ampere-hours is dependent upon the current consumption, the battery, nevertheless, may be used successfully in circuits drawing as high as 2 or 3 A.

This non-spillable battery weighs about 14 lbs., and measures 4 x 6 x 11 1/2 ins. long.

ALL-WAVE PORTABLE (455)

A 6 TUBE 110 V. A.C. set incorporating the following tubes: 6DG oscillator; 78 first-detector; 78 I.F. amplifier; 77 second-detector; 42 output A.F.; and 80 rectifier. The receiver is extremely sensitive, and covers all wavelengths between 15 and 550 meters, in 4 steps. The dial is color-coded for each of the 4 ranges.

A tone control is provided; also, a manually-operated I.F. trimmer for obtaining maximum sensitivity and selectivity. The power output is 3 W. This portable, which weighs 12 lbs., measures only 8 x 12 x 6 ins. deep.

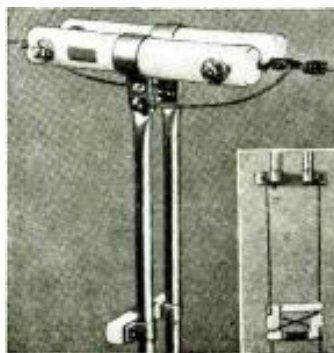

Left, a short-wave sending antenna system. (No. 453)

Above, a 3 V. "A" battery, utilizing 40 "B"-size cells. (No. 454)

THE 12A7 TUBE (No. 459)

THIS is an "outlaw" tube. That is, it has been marketed during the moratorium (in effect for the last few months) against the production of new tube types for a time, at least.

The feature of this tube is that it incorporates in one envelope an A.F. pentode and half-wave rectifier. The latter section of the tube makes it convenient to design "self-power" equipment in which a pentode develops its own D.C. high-voltage supply from an A.C. line supply. (See "A Beginners' All-Electric 1 Tube A.C.-D.C. Set," in this issue.)

The 12A7 (12 V. filament terminal voltage; A. or amplifier; and 7. the number of elements within the envelope) has a small 7 prong base. Looking at the tube prongs, and reading clockwise, the elements connect as follows: heater, pentode plate, pentode grid No. 2, rectifier cathode, rectifier anode or plate, pentode cathode grid No. 3, heater; pentode grid No. 1 is a top cap connection.

There is a separate 6.3 V. heater for each unit, the heaters being connected in series internally; thus, the rated heater voltage is 12.6 V. The current consumption is 0.3-A.

The characteristics of the 12A7 are as follows:

Pentode Unit				
Plate	S.G.	C.G.	Plate	S.G.
Volts	Volts	Volts	Ma.	Ma.
135	135	13.5	9	2.5
Amplification Factor 100				
Plate Impedance . . . 102,000 ohms				
Mutual Conductance 975 micromhos				

Rectifier Section	
Max. r.m.s. volts, per plate.	135
Aver. max. D.C. output, ma.	30

NEW RESISTORS (No. 460)

THREE new resistors have just been marketed by one manufacturer. The units shown at A and C are precision wire-wound type; the ceramic core is grooved, with adjacent sections wound in opposite directions. The distributed capacity is extremely low. These resistors are made in values of 1 ohm to 1 megohm, and an accuracy of plus or minus 1%. The type shown at A is provided with wire terminals; the unit shown at C has been converted to ferrule type by the addition of separately available ferrule terminals.

(Continued on page 742)



All-wave portable. (455) A 6 tube, 110 V. A.C. set weighing only 12 lbs.



A 12A7 tube. (No. 459)



New resistors. (No. 460)



A tube puller. (No. 461)

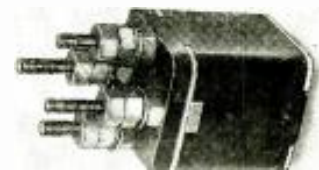

A dry-disc detector. (No. 462)



Battery-type ballast. (No. 463) This device eliminates rheostats.

AMPLIFIED CHIMES FOR SCHOOLS—CHURCHES

Here is a new idea in P.A. installations which should prove most lucrative to men in that field. Churches should be interested in these chimes for replacing heavy, cumbersome steeple bells. Schools can use them where an organ installation is too expensive, or as an auxiliary to the organ.

J. T. BERNSELY

MOST people conceive P.A. equipment as being employed for the sole purpose of amplifying and projecting speech and music, and as a matter of fact most installations have been made from this angle. Generally, amplifier equipment is installed for ballyhoo purposes, or for projecting sound in a location where the acoustics or area are against the possibility of the average human voice being sufficient. Present installations of P.A. equipment in churches and schools are illustrative of the need for amplifier equipment to overcome the aforementioned difficulties. Furthermore, it may be conservatively stated that more than 50 per cent of the churches and schools are now equipped with P.A. equipment for the purpose of extending the range of the ministers' or preachers', or lecturers' voices so as to cover every nook or recess of an auditorium. How then, can further sales be made along P.A. lines if

churches and schools are already equipped? The answer lies in the subject content of this article—the installation of chimes, which is an innovation in this field, and which should readily interest officials of the ecclesiastical and educational divisions.

What church does not aspire to having a carillon—but, how many churches can afford the complete cost of such a system besides the elaborate installation expense that it includes? Not many, of a certainty, or else we would find this instrument more universally used.

And yet—to those who are not aware of it—chimes will more than satisfactorily simulate the melodic notes obtained from carillon bells. They are considerably less expensive; the installation is much more simple; the flexibility is greater, since a chime installation can be moved or changed without any great difficulties involved; they can carry further (projection of sound) since this factor is only a question of the size of the amplifying equipment and horns, and last but by no means least, they permit an accompaniment of either organ or choir, which is not even remotely possible with carillon bells.

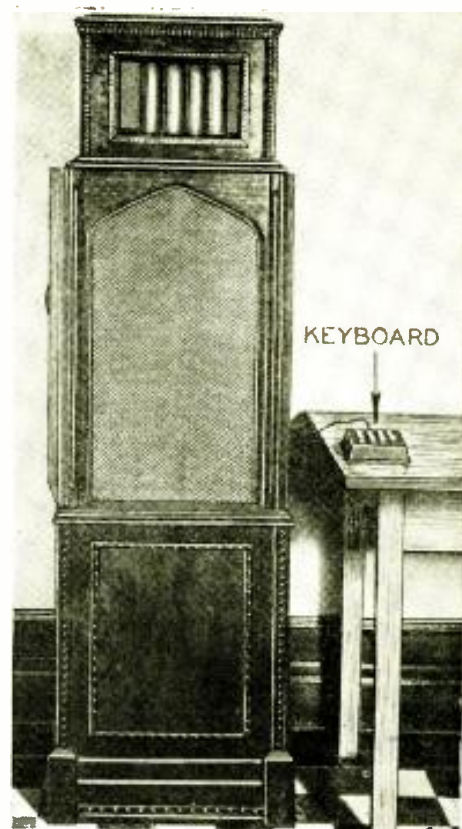

Fig. A

Four note chime outfit and keyboard.

Applications of the Chimes

Insofar as schools are concerned, the application of chimes is not quite as practical, but nevertheless, as an adjunct, it has interesting possibilities. It may be used as a substitute for, or auxiliary to an organ, providing the essential number of notes (pipes) are obtained. Or it can be employed as a "time-announcing" system for announcing class sessions. A small chime system, strategically located with a medium-sized amplifier and horn arrangement, will be sufficient to cover the entire school. It may even be used in conjunction with the school clock (this also applies to churches) to announce the hour or half-hour, by one chime combination; and quarter-hour, by another chime combination. Thus, with the latter suggestion the prestige and dignity of the school can be enhanced, by substituting melodious tones or notes for the noisy school bell or electric gong which is more commonly employed.

One more suggestion, before proceeding with description and construction data, to the P.A. man. It is hoped that he seriously digests and considers all of these applications, because the sales and installation of chimes will prove not only lucrative but will add a considerable amount of prestige to his reputation (which in turn will aid him in securing other installation jobs.) In the old days we used to see (and hear) quite a number of steam calliopes, mounted on trucks to ballyhoo circuses or shows "come to town." Many amusement parks still use this device for advertising special performances, or side

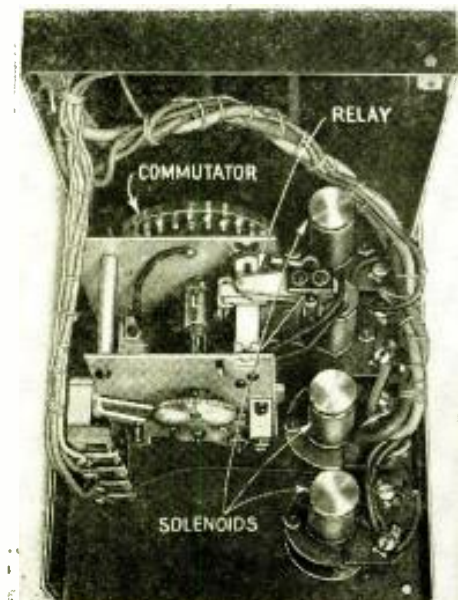

Fig. F

Internal view of chime control box.

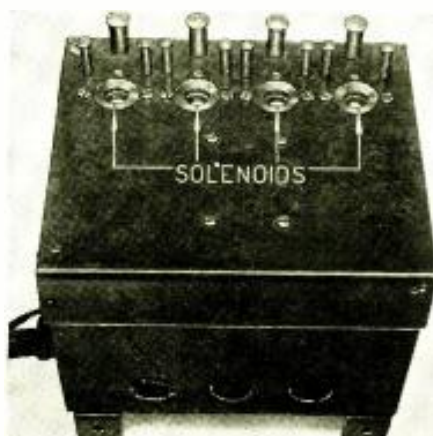

Fig. G

Solenoid plungers and chime supports.

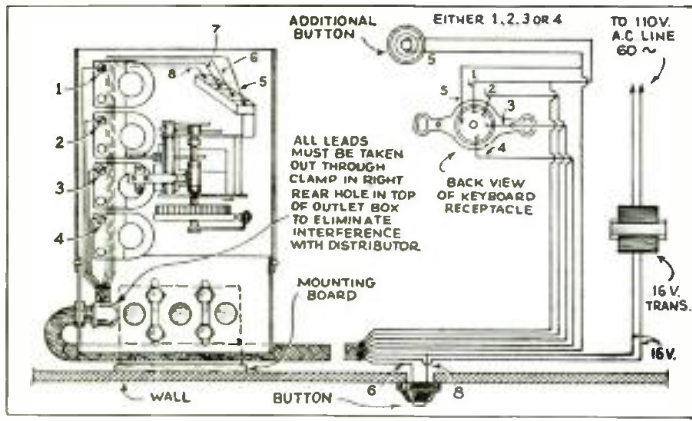
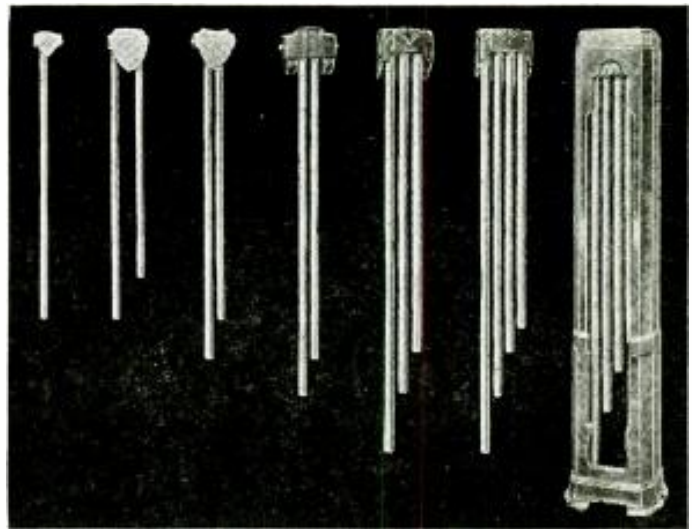

Fig. 1, above. Schematic illustration of internal construction of chime box. Fig. B, right. Standard Telechime outfits; more comprehensive ones are available.



shows, etc. While steam calliopes are admittedly "loud," their mechanism is such that they are not only expensive but also apt to give trouble. The pipe reeds of most so-called "steam" calliopes are not really actuated by steam but by air which is fed from a tank (supplied by a compressor, which, in turn is driven by a separate gas engine). There are many faults to be found with such an arrangement. Amplified chimes can be employed for the same purpose at considerably less cost; and, greater volume being obtained, will provide just as great "ballyhoo" attraction.

Construction of Chimes

Chimes are simply hollow pipes which when properly struck will vibrate causing the air within and surrounding it to vibrate, and thus produce a sound. The number of vibrations, or the pitch of the sound is contingent upon the physical dimensions of the pipe, just as the note from a violin string can be increased or decreased in pitch by decreasing or increasing its length by placing the fin-

ger across it. If we have two various-sized pipes we can get two notes—24 different pipes will produce 24 notes (3 octaves); or, by striking 2 or 3 pipes simultaneously, we can produce various tone combinations. An xylophone is a striking illustration, for comparison purposes, of how various lengths of reeds (or pipes) will produce tones or, in proper combinations, melody.

However, in this particular chime outfit the pipes instead of being operated manually are operated electrically. Electrically-operated solenoids which are controlled by a keyboard, similar to the piano type, strike the top of each pipe to cause the vibration necessary for sound. The unit which contains these solenoids (shown in Figs. F and G) also includes an induction-type motor which has a commutator-like attachment for obtaining note combinations in succession when only one key or button is pressed. Thus, it is possible to obtain a series of chime notes that are a reproduction of the Westminster chimes if one certain button is pressed; or, by

(Continued on page 741)

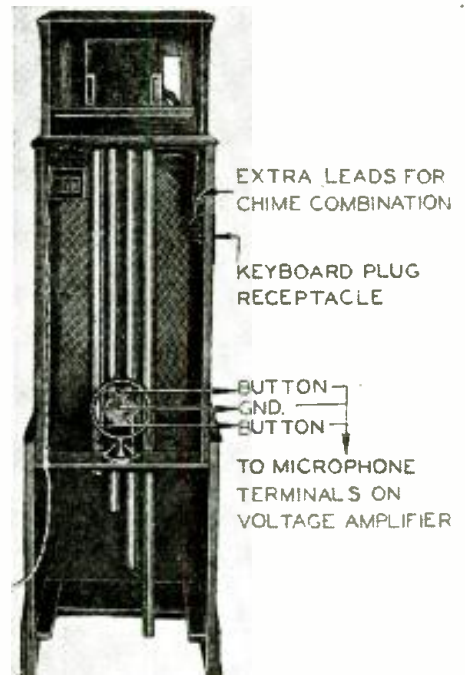

Fig. C
Rear view of chimes and microphone.
Fig. D, below
Voltage amplifier and connections.

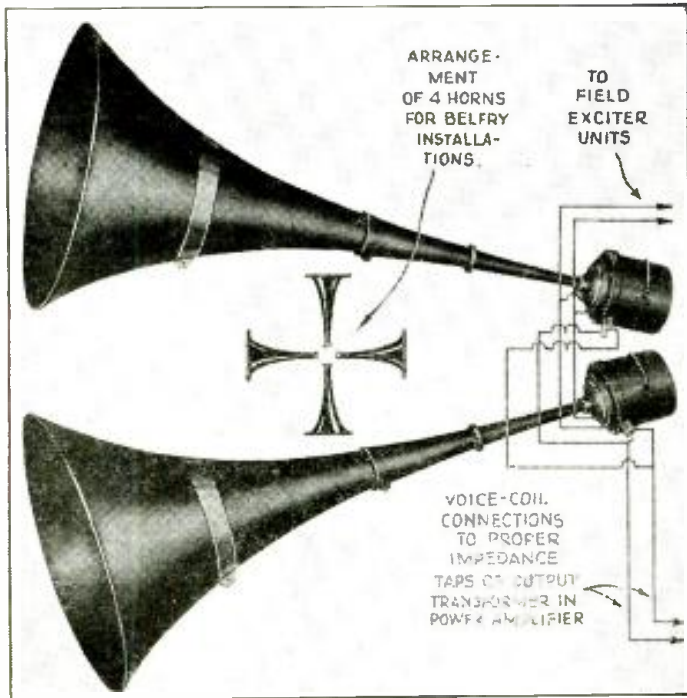

Fig. H, left
Four trumpet-type horns are recommended for belfry installations. Small installations require fewer horns.



(Courtesy, Simplex Elec. Co.)

Fig. E, right
Power amplifier (50 watts) employed only in large installations.



RADIO-EQUIPPED POLICEMEN

Recent advances made in receiver design and in short-wave transmission and reception promise to be a great boon to the forces of Law and Order. A miniature and highly efficient short-wave set is now being employed for keeping patrolmen "on foot" in constant contact with headquarters.



Courtesy, Western Electric Co., Inc.

Fig. A

A N. Y. police message about to go on the air.

R. D. WASHBURNE



Courtesy, Wide World Photos,
Fig. D

Radio-equipped policeman.

It is promising to note that every patrolling officer will, eventually, be radio-equipped. By means of highly-developed miniature receivers it is now possible to keep even the policeman "afoot" in constant contact with headquarters. The forces of crime, when arrayed against a combination such as that depicted by the photographs on this page, seem destined to be whipped to a standstill. While, by this time, a radio-equipped car that receives its instructions, via radio, from headquarters is not new to our readers, radio receivers for motorcycle police and for the policeman "on beat" will be a revelation to many.

Imagine a riot, bank hold-up, or what-will-you in crime, which is reported in time to police headquarters. As soon as the information is received it is immediately conveyed to the radio division of the police department where a dispatcher broadcasts it (see Fig. A). His broadcast will be, in all probability—with the new set-up—, "Calling all officers, Section—(number depending upon location of crime), go to Main and Tenth streets, bank hold-up," instead of the more generally-used phrase, "Calling car—(number)," that the all-wave or short-wave set owner is accustomed to hear.

Further, imagine police cars, motor-

cycle police, and patrolmen (who will all be radio-equipped) racing to the scene of the crime, as per the broadcast instructions. With officers converging from every direction, what a slim possibility the criminal has of escaping capture!

Due to the present development of radio technique all the above now sounds eminently reasonable, has every indication of being a successful method of combating crime, and seems logically simple. Actually, while this arrangement is now assured of being practical, the development of the receiver for the policeman "on foot" was a bit more involved.

It was essential that the design of the set incorporate as few tubes as possible, the mechanical dimensions be as small as might be necessary, that provision be made for signal pick-up (antenna), that convenient housing be arranged for the necessary batteries which must supply "A" and "B" current, and finally, that the efficiency be of as high an order as required to obtain consistent and reliable reception. These were design factors that had to be evolved, but in addition to the aforementioned, provision had to be made for portability (extreme lightness of weight, so that no physical interference would be experienced by

(Continued on page 760)

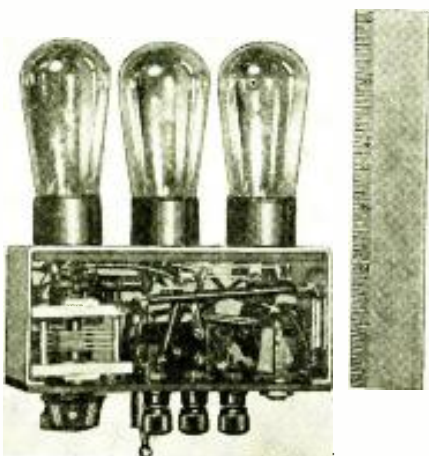

Courtesy, RCA-Victor Co., Inc.



Fig. C, above
Radio-equipped police car.

Fig. B, left
Receiver chassis of patrolman's receiver.

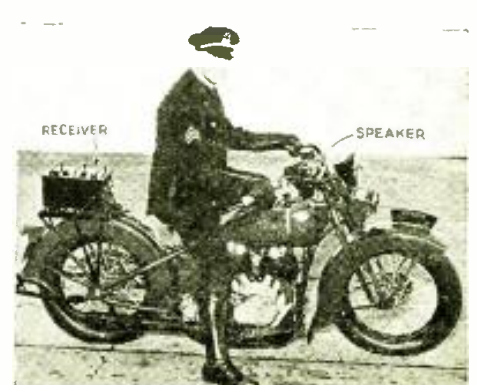

Courtesy, Western Electric Co., Inc.

Fig. E

Police motorcycle radio-equipped.

UPLIFTING THE SERVICE PROFESSION

The servicing industry has been, and still is, in an unsettled state. There has been a pronounced lack of cohesion, no tendency towards co-operation, nor any degree of success in the settling of problems that retard the progress of that branch of this industry. In this article the author discusses some of the problems and possible solutions, in addition to supplying valuable test equipment data.

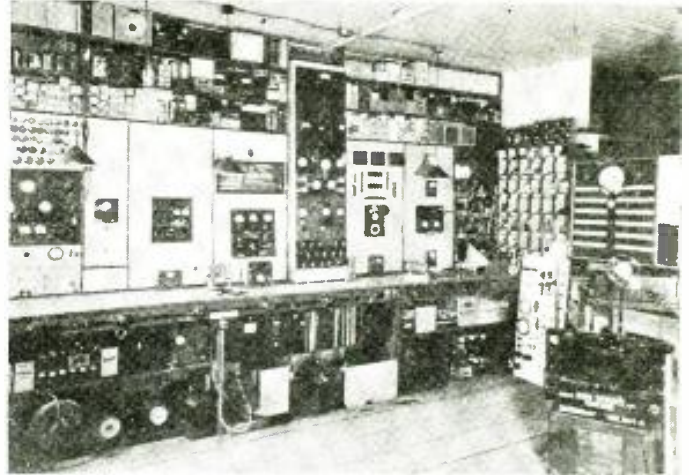

F. E. COLT

WITH radio as one of the large industries in the United States today and its great development since 1920, the "art" of radio repairing now becomes the greatest and most serious factor of the industry.

Before going into our subject of radio service shops, may the reader of this article concentrate his thoughts and draw a mental picture of the radio field from a few facts noted here.

It is conservatively estimated that there are at the present time 60 million radio listeners. Now let's use this 60 million as our base figure to give our imagination a chance to work out a few points regarding the art of radio servicing.

More Than 12 Million Sets

If 60 million people listen in, I do not believe it far out of line to say that one out of every five is a set owner. If so, we obtain a figure of 12 million for the number of radio set owners. (We all know there are many more radio sets than this but I am only using this as a thought towards the importance of a radio service shop.) Twelve million radio-set owners may only mean to some Service Men 12 million dial twisters but to the trained Service Man it means, in turn, 12 million sets to be serviced.

(If the reader of this article is also a reader of radio publications, and reads the editorials in RADIO-CRAFT by Mr. Hugo Gernsback in which he gave a very interesting account of how radio sets wear out [refer to RADIO-CRAFT editorial "Aging Radios," December, 1933]. To the serious minded radio man this editorial is a wonderfully quick analysis of important things which will give trouble and need servicing.)

Now with 12 million radio sets to repair, let's see what this means. Sup-

(Continued on page 750)

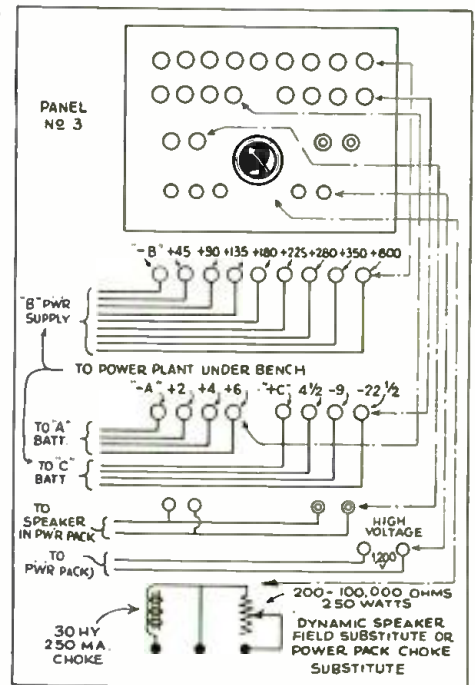

Fig. A, top

Dakota Radio Service Co., Yankton, S. Dak.
First Prize Winner in National Union's "Best Service Bench" contest.

Fig. 2, above

A terminal board test panel.

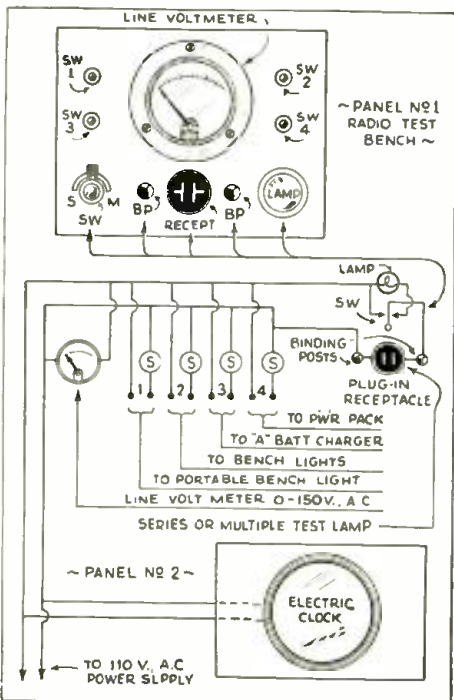

Fig. 1
Line test panel.

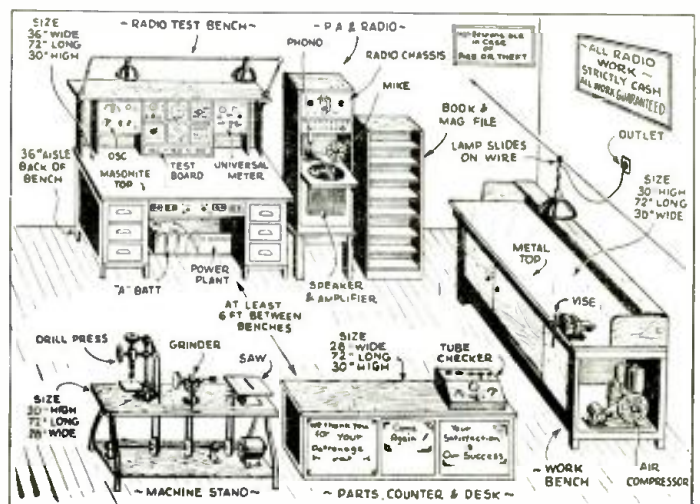

Fig. 3

Schematic of a layout for a well designed service shop. Auxiliary test equipment shown here are described in separate drawings with all pertinent data.

A "SUPER" BATTERY PORTABLE

Here is a receiver that has been tested all over the country and was found to out-perform some very expensive sets in localities where reception was almost impossible. While the set described is shown as a portable, the chassis can be readily adapted for rural or farm use, inasmuch as the entire receiver is operated from batteries. All pertinent constructional data are included.

A. M. WENGEL



Fig. A
Completed appearance of the "super" set.

DURING a recent trip of the author to the East the editorial staff of RADIO-CRAFT magazine became interested in the set illustrated and described in this article, and, after giving it a thorough checking up, decided that perhaps many of their readers would enjoy building one like it for their own pleasure.

In the past it has been difficult, if not impossible, to build a practical portable radio set, but since the advent of screen-grid tubes and the great advancement that has been made in the dry battery during the past two years, there is little excuse for the lack of good portable sets on the market.

The degree of perfection attained in the home radio field has taught us what to expect in radio and we are not satisfied with less in the sets we want to use outside the home. This brings us to the point of "what is a practicable portable radio?"

What This Set Will Do

The 6 tube battery portable set described will equal in performance any home receiver—except in volume and tone quality, due to the inefficiency of available speakers. (In other words it will equal home radio sets in tone if attached to a speaker of equal quality.) However, it will perform on all stations with good volume and reasonably good tone on its own midget speaker.

The only aerial ever used is the one built in the cabinet,

so it is *completely portable*, and will play with good volume even on difficult stations while it is being carried down the street.

Salesmen have told the writer, "I could take it up to my hotel room at night, and not have to sit in my car in the street or garage to hear the basketball game, or 'Amos and Andy.'" The farmer has said, "I could take it to the barn or field and hear the market reports while I am working." The business man says, "I could transfer it from my office to my car, to my boat, to my lake cottage, to my hunting shack." And Mother says, "Yes, and to the hills or woods for picnics, and at home the children could listen to their favorite programs in their rooms, and let the family enjoy a peaceful dinner hour." And so the comments run on and on.

The writer has tuned in distant stations while riding in New York subways, in trains, in all-steel skyscrapers! With the set directly under the antenna towers of powerful stations in New York and Cincinnati, distant stations have been tuned in within 40 kc. The set has been operated in the deep woods of northernmost Wisconsin, in the iron and copper country, stations as far distant as Chicago being pulled in, in the day time. This the natives agreed no large home set had ever equalled to their knowledge.

In summary, it is one that is small and light enough to be readily carried about, playing as it goes, entirely self contained, and equaling in sensitivity, selectivity, and consistent

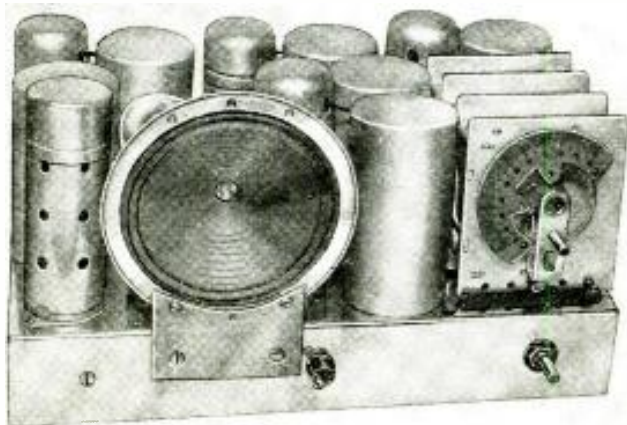

Fig. B
Chassis layout. Note compactness of assembly.

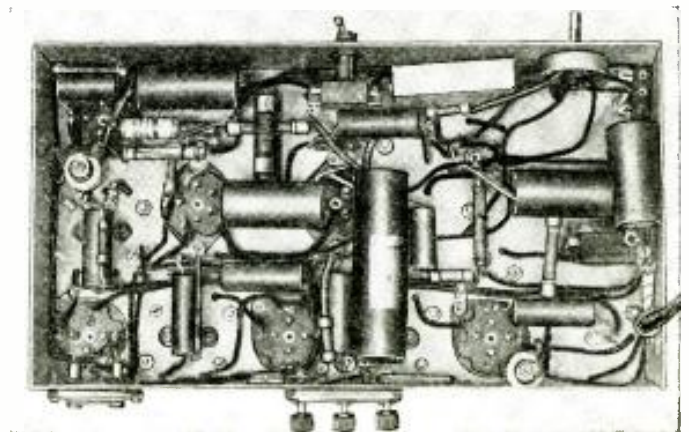
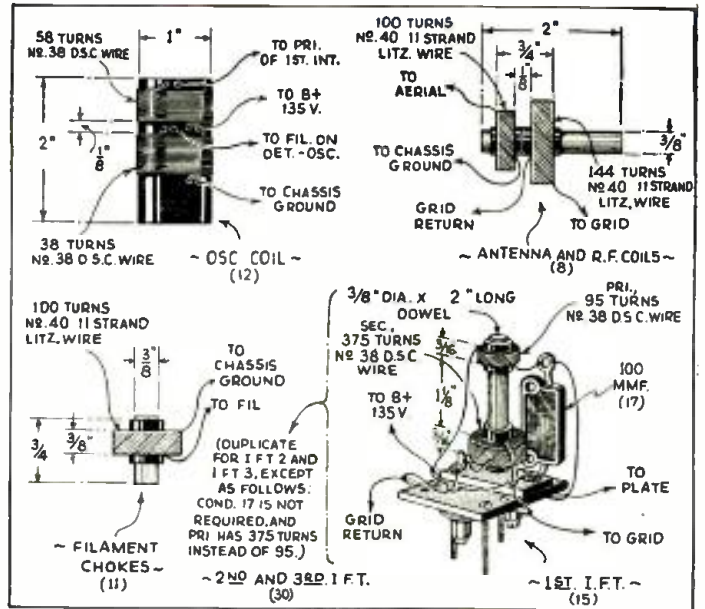

Fig. C
Sub-chassis layout; the wiring scheme is simple.



Fig. D
 "A," "B," "C" batteries in one block. Although the "C" battery section of this unit is not required for the "super" set, it is available for other set designs.
 (Courtesy, name of manufacturer upon request.)

Fig. 1, right
 Coil constructional data. The antenna and R.F. coils are wound in honeycomb fashion. Spacing between pri. and sec. windings of this and the int. freq. coils should be strictly adhered to for good selectivity.



operation the best home radio sets. In addition there is one advantage which is unquestionably characteristic of all battery operated sets; that is, less electrical interference and noise. (This is an especially great advantage over auto radio sets.)

The results obtained in this set are due to the use of a new circuit, for which patent application has been made.

Circuit Features

On the circuit diagram you will note a ground on the 1st R.F. tube filament, and also one on the detector tube filament. These grounds should be heavy braided wire and grounded directly from the positive filament on the tube socket to the chassis. These grounds, as well as the filament chokes should not be overlooked as they are very important. The antenna lead from binding post to the coil should be shielded and this shielding grounded at both ends.

There are six tubes in this set. Five are of the 951 type, and the sixth, a 950. The 951 is a tube exactly like the 32 except the glass envelope is the size of

that used on a 57 or 58 tube. This saves space. The 950 is a tube much like the 33 except that it consumes about 8 ma. "B" battery current, and 120 ma. "A" battery current. The 950 and 951 tubes are manufactured only by one company; type 32 and 33 tubes may be substituted, but the chassis would have to be enlarged, and shorter battery life would result. The total "B" drain of the set is only 13 ma.

A certain battery company will shortly have a combination "A" and "B" battery on the market which will connect the entire unit to the set with one plug, and so designed that the "A" and "B" units will give equal life. In other words, the "A" unit power will not be low while the "B" is still high, or vice versa. These batteries are extremely long lived, therefore economical, and will make replacement a simple matter. They are now being made for larger sets, but until the size to fit this set is in the hands of the dealers, the builder of this portable will get excellent results using 3 No. 5303 batteries and 4 No. 6 dry cells. The

(Continued on page 749)

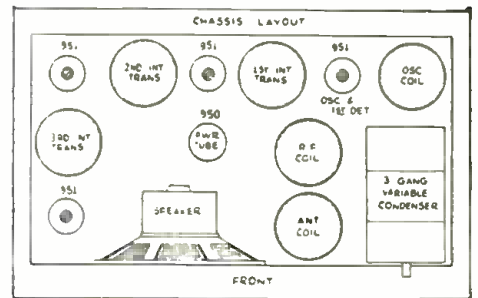

Fig. 3, above. Chassis layout.

Fig. 4, below. Sensitivity curve of set.

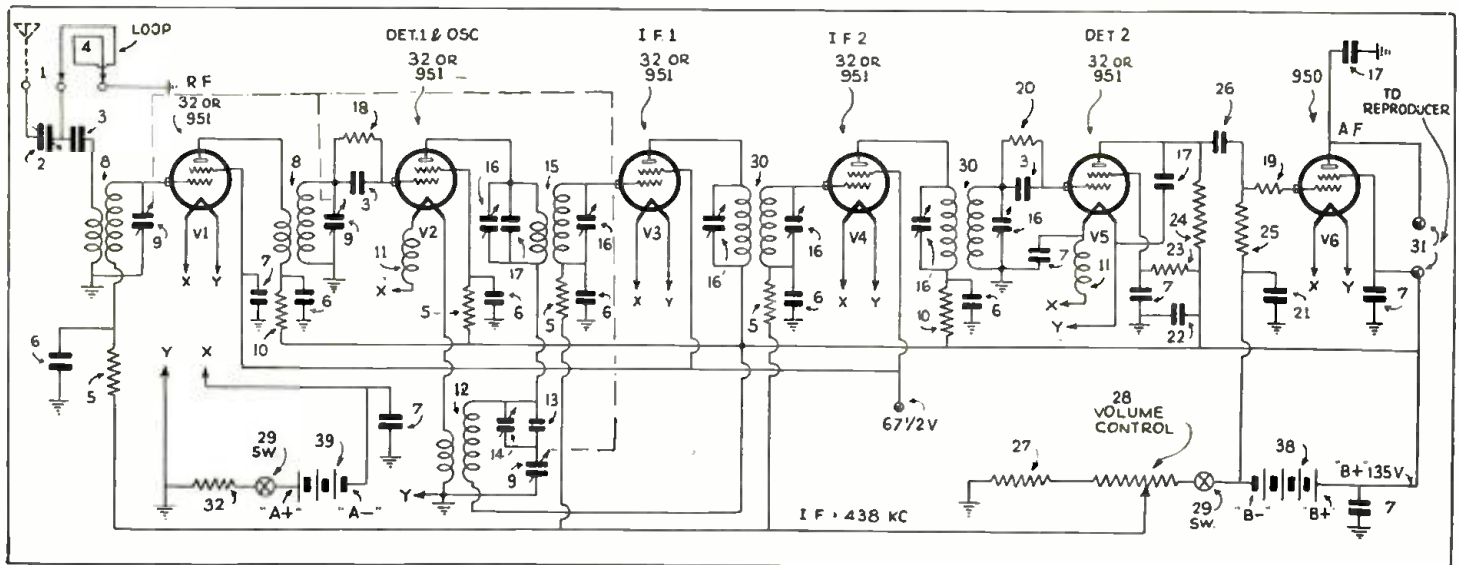
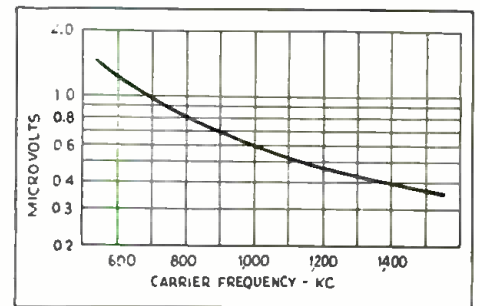

Fig. 2
 Wiring diagram of this receiver. A loop may be employed and good results obtained. A sensitivity curve is shown above, upper right.

ULTRA-PORTABLE P.A. SYSTEM

Some very compact portable amplifier systems are herein described. They include speaker, microphone, phono-motor, and pick-up, in one case.

LEON LITTMANN*

IN THE early days of radio, the complete receiver consisted of so many separate pieces of equipment such as table cabinet, batteries, eliminators and speakers. As time progressed, an entire radio receiver was completely unified into one compact item, which is as

* Chief Engineer, Coast-to-Coast Radio Corp.

it should be. The same story holds true in the amplifier field—whereas it was the general procedure to employ similarly operated units, the demand has been to unify such P. A. systems.

With the latter goal in mind, three series of 7½ W., 2A5; 12 W., 2A3; and 13 W. 79 class B (6 V. storage battery operated) amplifiers have been designed. The carrying cases, when closed, mea-



Fig. A
The ultra-portable ready for operation.

sure 15¼ x 14¼ x 13¼ ins. The following equipment is included within the same portable case: a complete input mixer-fader control system, a phono-graph motor, a standard sized dynamic speaker and a double-button microphone and desk stand. Room for 50 ft.

(Continued on page 748)



Fig. B, left

A view of the amplifier, mixing controls, phono-turntable, pickup, and all in one side of case.

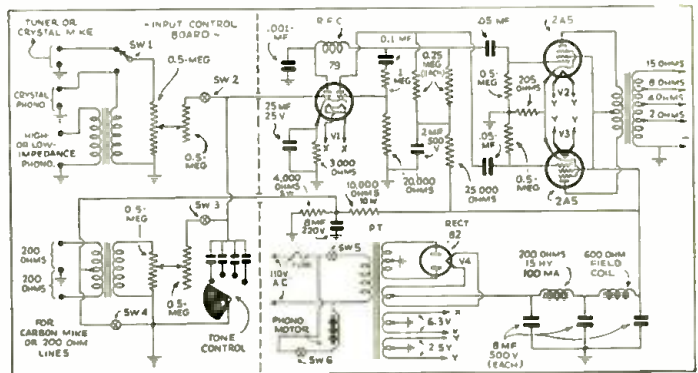

Fig. 1

Schematic wiring diagram of 7½ watt amplifier, using 2A5 tubes in the output stage.

THE RELATIVE MERITS OF CLASS A, A PRIME AND CLASS B AUDIO AMPLIFIER CIRCUITS

M. A. APSTEIN*

MUCH has been written on this subject in the way of definitions, circuit applications, and articles extolling the advantages of one given system over both of the others. However, a frank discussion comparing the advantages and disadvantages of all three systems has been conspicuously absent. It is the purpose of this article to point out these advan-

* Engineer, Simplex Electric Co., Inc.

tages and disadvantages, and to show that each system has its proper place in the field of amplification, and just what that place is.

It will be necessary at first, to review the fundamental basis of amplification in general. Figure 1 shows two curves, plotting grid voltage against plate current. Such curves merely indicate what plate current a tube will draw when a given grid voltage is applied to the grid. The grid voltage may either take the form of "C" bias or a varying A.C.

input voltage or, in actual operation, a combination of these two. A perfectly distortionless amplifier would have as its characteristic curve, a perfectly straight line. This would mean that the plate current wave form would be an exact replica of the grid voltage wave form; result: absolutely distortionless amplification. This theoretical curve is shown as the dotted line A—A. (Continued on page 746)

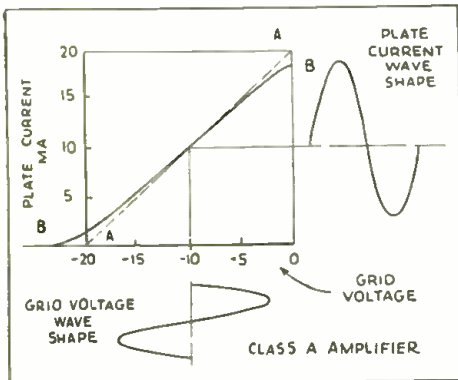

Fig. 1
Curve of tube in class A.

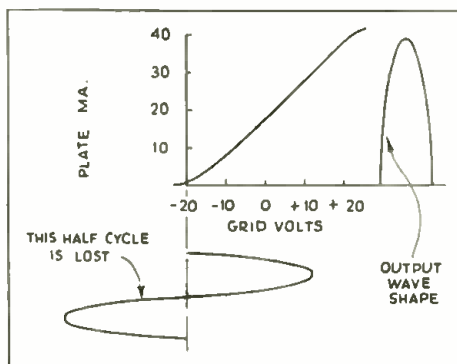

Fig. 2
Single tube biased for class B operation.

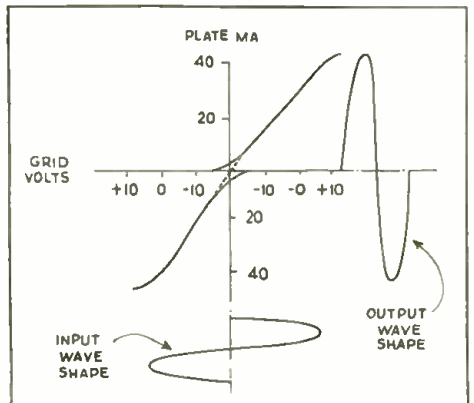
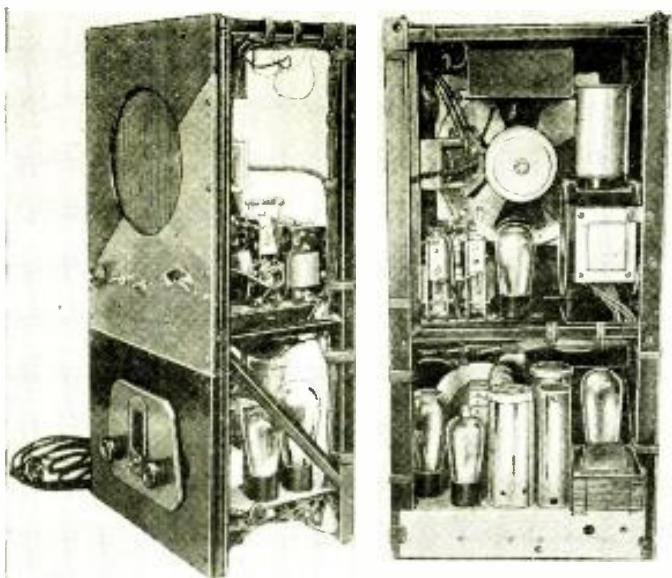

Fig. 3
Two tubes, push-push, class B.



AN AUTOMATIC PROGRAM CENSOR

RADIO-CRAFT, in the March, 1934 issue, was the first to announce a radio "robot" that automatically silences superfluous advertising. While this invention may never be put to use as an advertising "silencer," it may suggest some other equally practical application.

S. R. WINTERS

NO LONGER will it be necessary to endure half an evening hearing detailed advertisements on tombstones, dog biscuits, soap or "laughing water" in order to spend the remaining half enjoying entertainment. Geo. P. Adair, an electrical engineer, has just invented a novel device that seems almost human in its discriminatory powers to regulate an incoming radio program. It automatically cuts off the garrulous announcer or advertiser who sandwiches an "ad" between every note of music or tactlessly carries his advertising speeches to the point of nausea. This special receiver makes it possible for the radio audience to take as much or as little of advertising as they please, or to have an uninterrupted musical program if they so desire.

Of course, like many other inventions this one may never be put to wide practical use. In the first place, the people of the United States are well aware that the advertiser is the one who pays for the notwithstanding immeasurable pleasure afforded them by radio. Far more fortunate are Americans than the people of European countries where tax is levied on

individual radio equipment. In Germany, for example, the postman collects a radio tax at regular intervals that is set by the government.

And so that automatic "censor," just patented by its inventor George P. Adair, is explained to us not as a means to annihilate advertising, but rather as a restraint to be used when necessary. Or, as John B. Brady, attorney for Mr. Adair, aptly put it, to eliminate advertising would be to kill the goose that lays the golden egg for broadcasters.

It is quite satisfying to our romantic conception of the development of an invention to know that the material used principally in the construction consisted

of a baby bed, a wastepaper basket, coffee and baking powder cans, pie and cake pans and other discarded articles assembled by the inventor. Mr. Adair has built a number of these radio sets which operate splendidly.

Broadly speaking the invention relates to radio reception and particularly to a special circuit arrangement for radio broadcast receivers. Mr. Adair arrived at his conclusions and subsequent invention by basing it on the fact that the characteristics of the speaking voice are different from those of vocal and instrumental music. Except in very unusual cases there are few definite pauses in the latter, while in the speaking

voice there are numerous and quite definite pauses between syllables and words, and quite long pauses between phrases and sentences. If the electric waves caused by speech are rectified, the current resulting is of a pulsating nature, while in the case of music it is a direct current that varies little in amplitude.

The receiving apparatus serves in various ways. A circuit arrangement may be fixed so that silence replaces the extended advertising

(Continued on page 744)

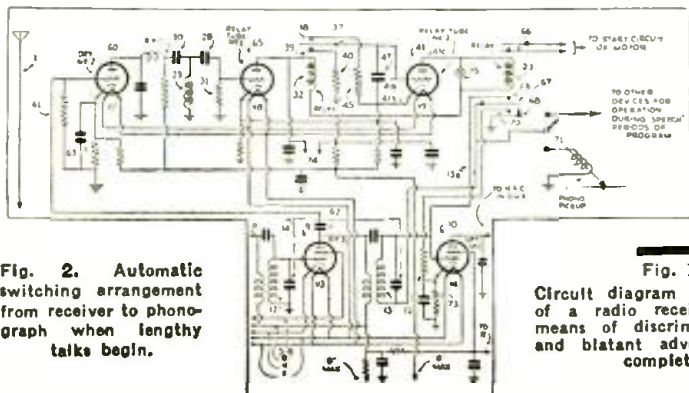
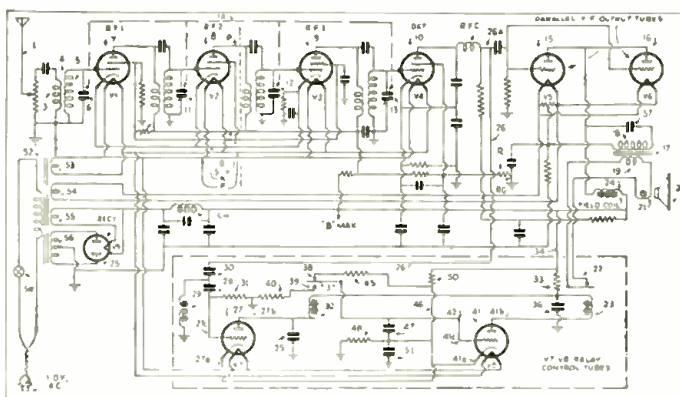

Fig. 2. Automatic switching arrangement from receiver to phonograph when lengthy talks begin.

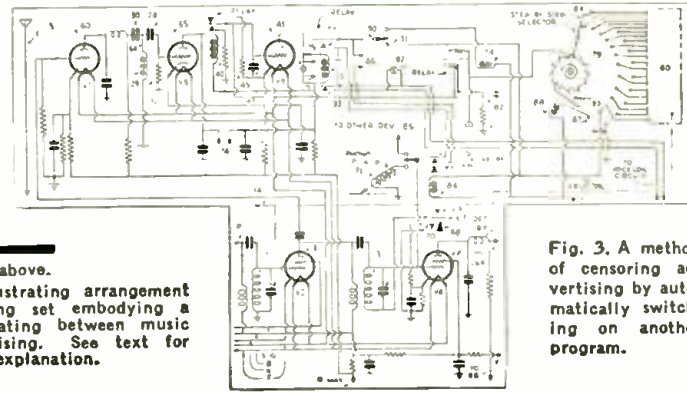

Fig. 3. A method of censoring advertising by automatically switching to another program.

Fig. 1, above. Circuit diagram illustrating arrangement of a radio receiving set embodying a means of discriminating between music and blatant advertising. See text for complete explanation.

A BEGINNERS' "ALL-ELECTRIC" 1 TUBE SET

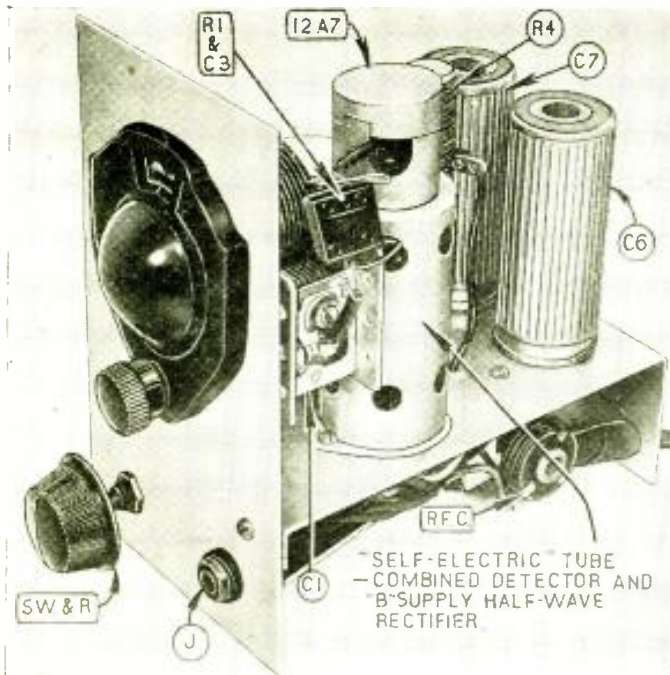

Fig. A. This set is simple in both appearance and construction.

It has heretofore been considered impossible to construct a 1 tube receiver that would operate from A.C. power supply, unless complicated design was involved. The receiver described was designed around a new tube that has just been released, the 12A7. It incorporates a power pentode and half-wave rectifier in one glass envelope. The receiver will operate on either A.C. or D.C., and its construction is so simple that even the beginner should have no difficulty in building it. The reception that is possible with this set will more than gratify the constructor.

F. R. HARRIS

A REALLY "1 tube" set, which would operate from the regular power lines—110 V., A.C. or D.C.—has long been the dream of experimenters but it has never, to date, been accomplished. There have, of course, been sets which were, technically, of the 1 tube variety, and which obtained their power from copper-oxide rectifier stacks ("A 1 Tube, Portable, Universal-Current Set," *RADIO-CRAFT*, January, 1933, pg. 400) and similar expedients but the complication and expense of these methods greatly overbalanced the advantages gained through the elimination of the separate rectifier tube. However there has just recently been introduced a new tube, known as the type 12A7, which combines a power output pentode and a half-wave rectifier in the same glass envelope and—behold— we have our 1 tube electric set! The completed set is shown in Figs. A and B. The schematic circuit is Fig. 1.

The 12A7 Tube

The tube is the heart of this circuit—without it, in fact, the circuit would be impossible. Its characteristics are given

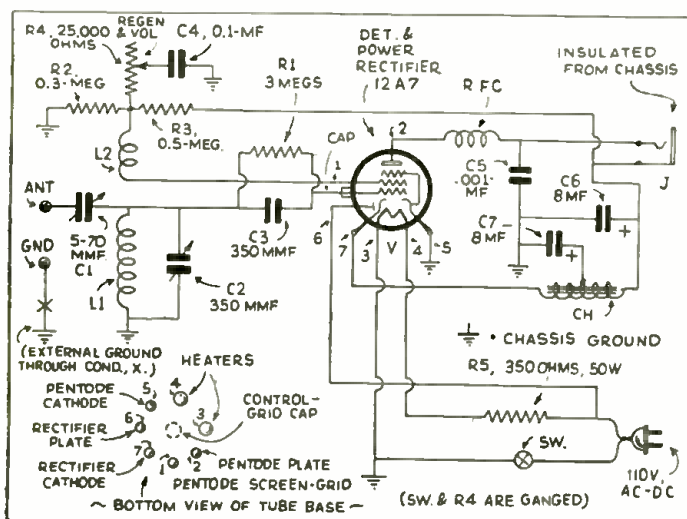

Fig. 1

Schematic wiring diagram of "all-electric," 1 tube set.

elsewhere in this issue. The glass envelope, of the standard size known as ST12, is the same size and shape as that used for type 58 and 77 tubes and others; it contains a pentode section practically identical with the type 38 tube, and a half-wave rectifier element. Each has its own cathode and its own separate base pins. The base is of the small 7 pin type and the control-grid of the pentode is connected to the tube cap. Base connections for the tube are given in Fig. 1. This tube has been used commercially in a pocket sized set recently brought out by a large manufacturer and should be generally available for replacement purposes by this time.

Construction

As will be seen from the photograph, the set is laid out on an aluminum chassis identical to those described some time ago in this department. The complete layout for the two pieces is given in Figs. 2 and 3. If other than the specified parts are used the layout will, of course, have to be changed accordingly.

Because aluminum is a metal many beginners are afraid to employ it in radio construction, being under the impression that it must be difficult to work with. It is, of course,

(Continued on page 759)

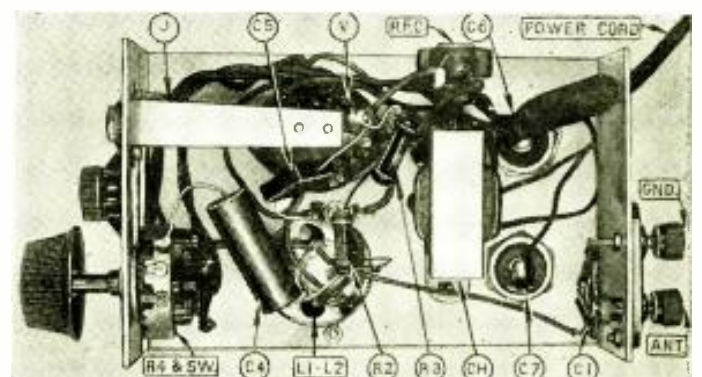

Fig. B

Layout and wiring—underside of chassis.

THE ANALYSIS OF RADIO RECEIVER SYMPTOMS

OPERATING NOTES

FADA FLASH-O-GRAPH

IN the past few months we have had considerable trouble in Fada model 48 sets with the flash-o-graph indicator tube. The tube would only light on very strong signals. We checked and rechecked the circuit and could find nothing wrong.

Shunting the 1 mf. condenser from the one side of the flash-o-graph, as shown in Fig. 1, permitted the control to be turned to the end, and the flash-o-graph would then work on all signals, even the very weak ones, without interfering with the operation of the set.

HAROLD S. JONES

KOLSTER MODELS 20, 23, 25

ONE common trouble in the above model is circuit oscillation.

These receivers have no adjustable neutralizing condensers and sometimes to do away with oscillation becomes quite a problem, especially after the set has been tampered with.

Reversing the antenna coil will sometimes affect a cure. Bending the corners of the small 75 mmf. condensers that shunt the grid suppressor sometimes is helpful. Another method is to increase the resistance value of the grid suppressors.

But all of the above may tend to stop oscillation by reducing the sensitivity of the receiver itself. If you are sure the other methods are unsatisfactory, try adding a 50,000 ohm resistor, R, in Fig. 2, in the control-grid circuit of the second R.F. tube, placing the resistor between control-grid suppressor and secondary, and chassis.

This method will stop circuit oscillation without reducing the sensitivity or affecting the R.F. tuning.

RUSSELL R. BRITTON

A DAY'S WORK IN A SMALL TOWN

A GREAT deal has been written concerning the possibilities in the medium-size town but to date I have read very little about the Service Man in towns having from 2,000 to 5,000 population. It might be a good idea for me to relate how I figured this town before I set up a shop.

The town has a population of 2,500 but it has a drawing capacity of around 10,000 and this is the most important item to consider. I divide the 10,000 by 6 (which constitutes the average family) and then, as there is supposed to be a radio receiver for every other

family, I divided the result by 2 which gives about 850 radio sets for the 10,000 population. Figuring that service on the average radio instrument will amount to about \$2.00 per year, we find that a year's business should be about \$1,750 or approximately \$150 per month. I believe that we can concede the fact that this is a very conservative estimate; it has proven conservative in my case.

To show what an average day's work is for me I have picked out the following as the routine of an average day. Now for the first repair call.

ATWATER KENT 37

THE lady of the house said that the volume control did not control the volume and I found this to be the case; also that the speaker rattled and a few tubes were needed. I brought it to the shop and removed the volume control, and after tightening it up and putting on some Nujol I replaced it—but still no control of the volume. Upon testing the volume control resistor, R, in Fig. 3A, I found that it did not have the correct resistance. Now I was in a hole (I never do carry an A.K. part for more reasons than one). I next disconnected the wires from this volume control and connected them to an external 5,000 ohm potentiometer. Ah! it worked—speaker trouble gone, too. The next thing was to get the potentiometer to fit inside the volume control housing. I took a $\frac{3}{16}$ -in. drill and re-drilled the housing for the new potentiometer. After sawing off the shaft to fit I put on a knob, returned the set to the lady and received \$6.30.

(Continued on page 754)

WHAT THIS DEPARTMENT IS FOR

It is conducted especially for the professional Service Man. In it will be found the most unusual troubles encountered in radio service work, written in a practical manner, by Service Men for you.

Have you, as a professional man, encountered any unusual or interesting Service Kinks that may help your fellow workers? If so, let us have them. They will be paid for, upon publication, at regular space rates.

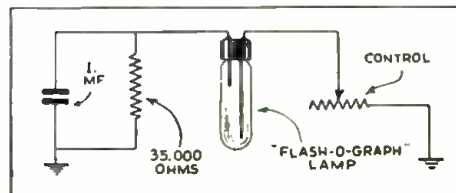

Fig. 1
Improving flash-o-graph operation. The 1. mf. condenser in shunt to the 35,000 ohm resistor solved a problem.

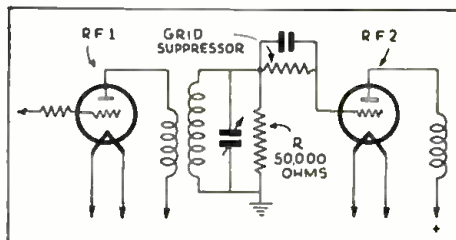

Fig. 2
Circuit oscillation in Kolster sets. An old stunt (the use of R), but an effective one in some sets.

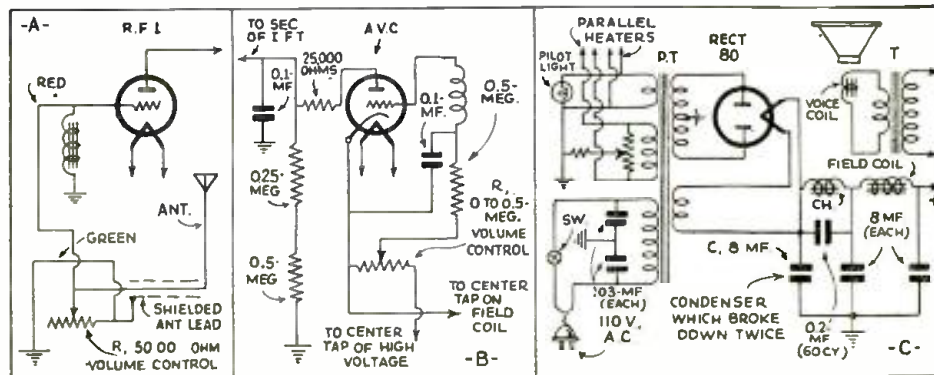
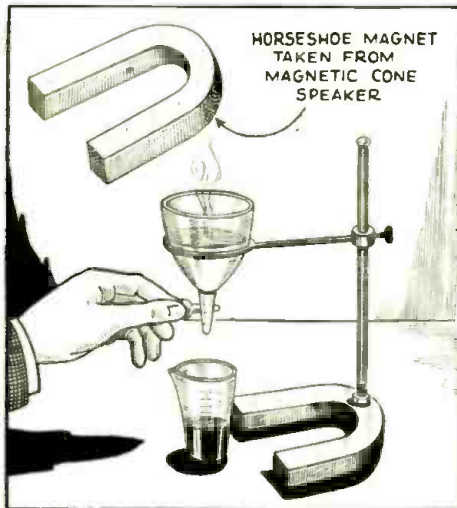

Fig. 3

A day's service work in a small town included the repair of an A.K. 37 volume control, as shown at A; a call in connection with the continuously full-volume operation of a Brunswick 17, B; and power pack trouble in a Majestic 210, C.

SHORT-CUTS IN RADIO



The horseshoe magnets of old cone speakers make admirable bases for chemical stands, etc. To drill the magnet it will first be necessary to anneal it by heating red hot and cooling slowly.

USES FOR OLD RADIO PARTS

For the suggestions contained on this page we are indebted to Mr. Joseph Leeb. Come on, Old Timers, let us have your "uses," for publication at space rates.

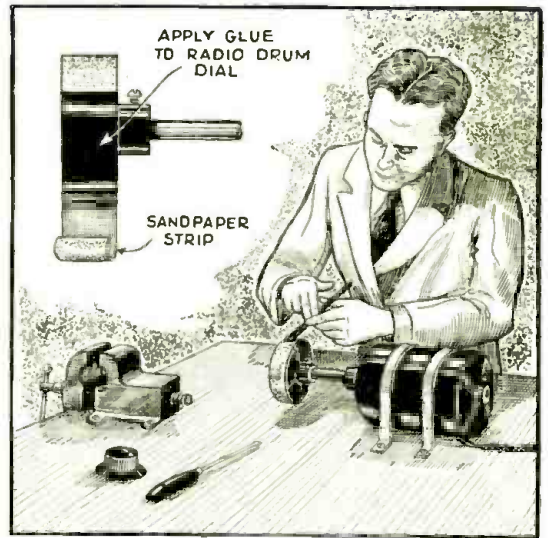

The drum dial taken from an old radio set makes an excellent sanding wheel or disc. Merely glue sandpaper of the desired grade along either the edge or flat side of the drum, and drive it with the "shop motor."

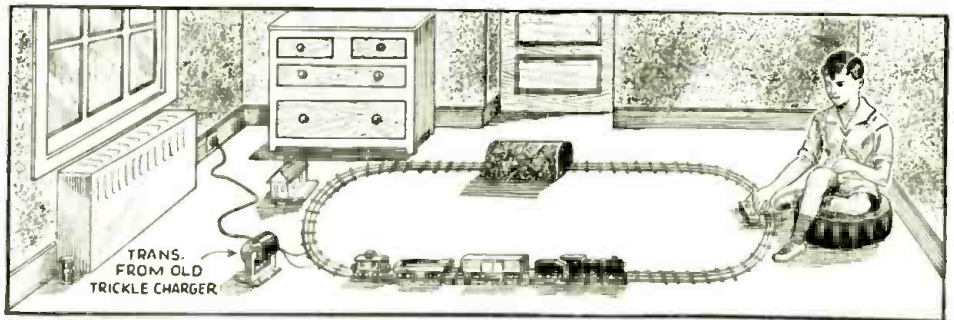

Trickle chargers now belong chiefly in museums, but, if you still have one that the junk man refused to take away, hold on to it. You may want to use the transformer for operating toy trains for the youngsters, miniature lights for a party, or to replace a bell-ringing transformer gone haywire.

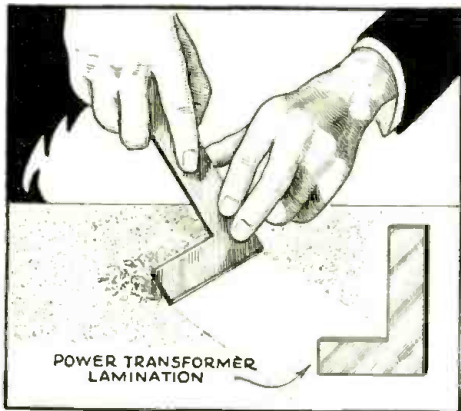

Laminations of old A.F. and power transformers usually have a punch-press burr that enables them to be used as excellent paint and wood scrapers.

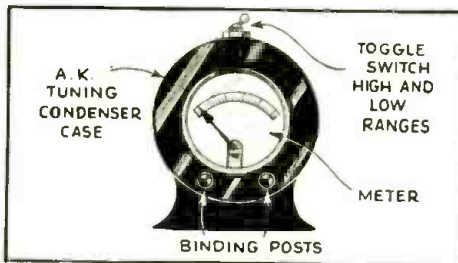

The bakelite tuning condenser case from one of the now venerable "open face" breadboard model A. K. sets will make a handy meter mounting.

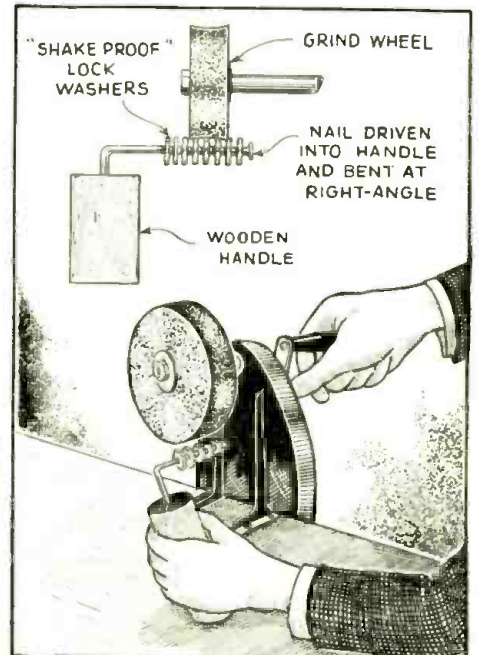

To dress down a grind wheel whose edge has become grooved or uneven, string a dozen or two heavy "shake-proof" lock washers loosely on a nail, driven into a wood handle and then bent over. Used as shown, the job will be finished in a few minutes.

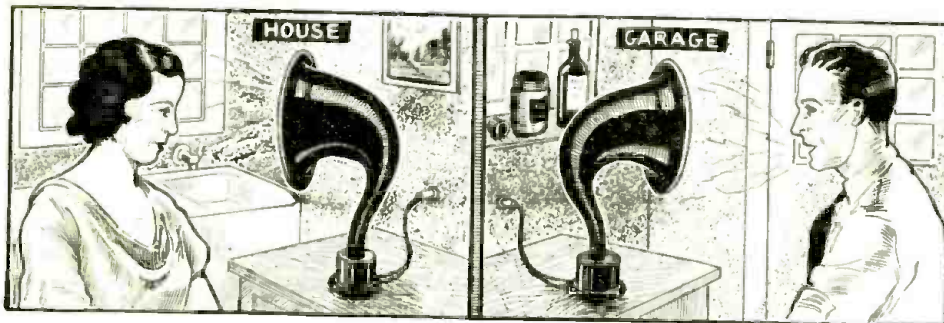

Horn-type speaker units which are no longer being used for their originally-intended purpose will function admirably as battery-less telephones. It is only necessary to connect two of the speakers in a simple series circuit. The "telephone" will work well over a distance of several hundred feet.

EMERGENCY TUNGAR "A"

Clarence A. Ruppel

AN EMERGENCY "A" supply may be obtained for the battery set using a Tungar tube, which has burned out, by using the scheme shown in Fig. 1. A Ford unit is ideal as the spark coil. As you are using raw line voltage on one side of the battery, disconnect the battery from the radio set. After starting the vibrator-type spark coil going, using the battery (or a suitable toy or good bell-ringing transformer) to excite the primary, the lamps in the bank will begin to flicker and create an arc; then, suddenly, the lamps will go bright, which indicates that you can now disconnect the spark coil and regulate the charging rate (the number of lamps in the bank) to suit. (If an ammeter is connected into the circuit at X, be sure to short it when "striking"—starting—the arc.)

This little trick has saved me inconvenient trips to town, and enabled me to give service to the customer, in several emergencies; also, it has brought me many more new customers.

EXTRUDED WASHERS

Ernest du B. Lukis

RADIO set builders and experimenters often are handicapped by lack of extruded washers for mounting panel-control units. Make them, then, as per Fig. 2.

By saving bakelite tooth paste screw caps and others of various sizes one may accumulate quite an assortment of very servicable extruded washers simply by drilling through the top of the cap, and reaming out to size.

SELECTING TELEVISION TUBES

A. J. Feingold

IN ANY television receiver the usual method of changing from speaker to neon lamp is as shown at A in Fig. 3. However, some television experimenters may desire to change quickly from neon lamp or speaker to crater lamp.

This is easily accomplished by means of an old Philco "B" eliminator switch, connected as shown in Fig. 3B.

This type switch has 8 contact points (4 on each side). On one side of the switch short each pair of terminals; this will result in 2 contact points on one

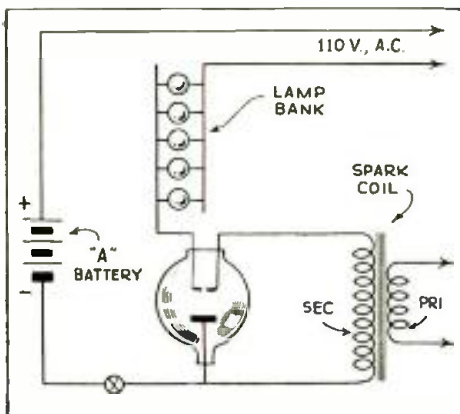

side of the switch and 4 on the other. The switch has now become a D.P.D.T. snap switch.

(The output coupling for the crater lamp employs the arrangement recommended by Mr. Clyde Fitch, in the May, 1932, issue of RADIO-CRAFT.)

METER NEEDLE REPAIR

Bill Evans

AT ONE time or other we are bound to damage a meter, what with all of our carefulness being cast aside to save time. High factory repair charges and inconvenience will be overcome by using the simple remedy shown in Fig. 4.

Although the needle may be overlapped, as shown in the top portion of the view, it may be undesirable to shorten the needle to the extent which this system may require.

The method of using a "splint," as shown in the lower detail, will retain the original length of the needle but will add extra weight, and on very sensitive meters this weight must be counter-balanced.

In doing this, mount the meter in an upright position, cut a piece of metal the same size as used in the splice, and wrap it around the counter-balance end of the shaft, sticking it in place with enamel.

EMERGENCY VOLUME CONTROL REPAIR

W. T. Clayton

ALTHOUGH especially adaptable to the Radiola 48, the repair suggested in Fig. 5 may be applied to many other makes and models of radio sets having similar connections of the volume control with the same resistance value for each section.

MODERNIZING A PAM 16-A AMPLIFIER

Ansel A. Searles

WE HAVE a type PAM 16-A audio amplifier which employs a type 27 tube as first A.F., two type 10 power amplifiers connected in push-pull for the second A.F. stage, and a type 81 rectifier; the complete circuit is shown in Fig. 6. During a burst of enthusiasm during the past winter, the 10's were

(Continued on page 763)

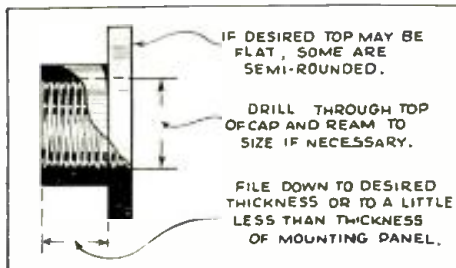

Fig. 1, left

An emergency "A" supply circuit.

Fig. 2, above

Make your own extruded washers.

NOTICE:

Mr. Experimenter—what is your idea of time- or money-saving ideas? Most radio men have a great number of short-cuts that they employ in their daily work—short-cuts that speed up their work or save them considerable cash. Sometimes the convenience these impromptu artifices afford is invaluable.

RADIO-CRAFT will pay, upon publication, space rates for ingenious expedients in radio—and its allied fields.

The items may include ideas in radio reception; photoelectricity; television; electronic music; radiodynamics; and public address.

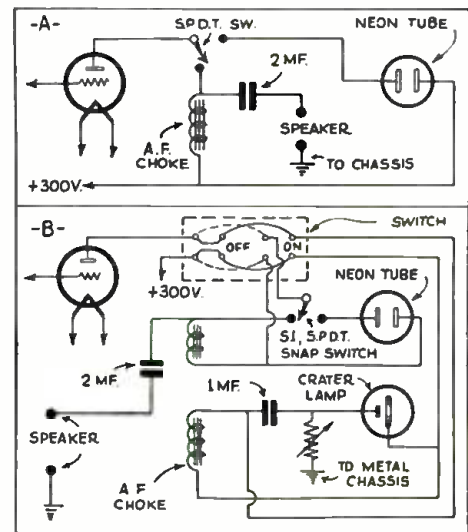

Fig. 3

Selecting the television neon tube.

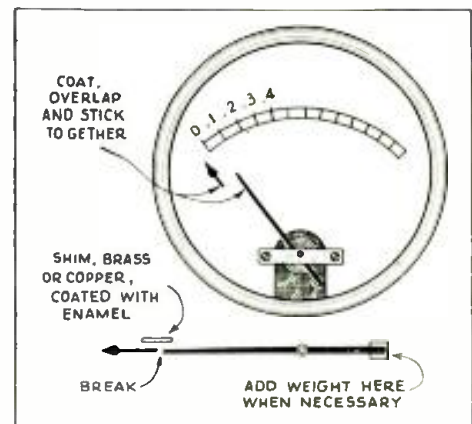

Fig. 4

Repairing that broken meter needle.

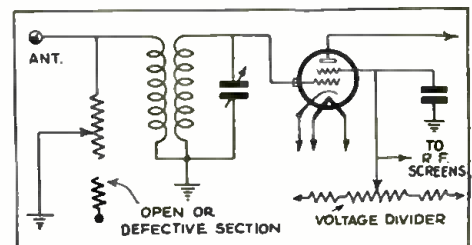
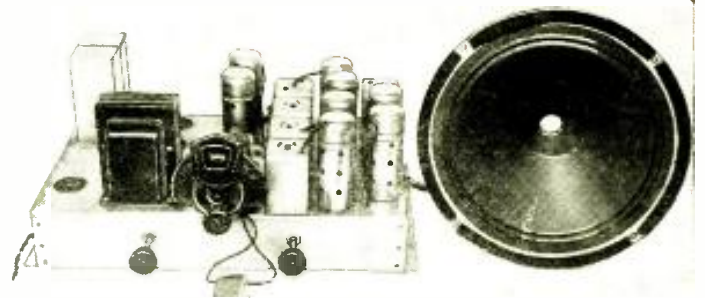

Fig. 5

For a temporary repair, rewire as shown above.

11 TUBE SUPER BROADCAST RECEIVER

A modern superheterodyne broadcast receiver, that incorporates such features as noise suppression stage, push-pull amplification, hi-mu tubes, etc.



Courtesy Radolek Company

THIS RECEIVER embodies all of the latest principles of modern broadcast engineering, such as automatic volume control, inter-carrier noise suppression, a phase reverser system (to obtain push-pull A.F. with resistance coupling), and incorporates latest tubes recently announced. Its characteristics are far superior to those found in factory-built sets selling at several times its cost. The greatest care has been used in selecting parts of the highest possible quality and its careful construction will reward the builder with the highest sensitivity and selectivity and best fidelity that is at present possible to obtain at any reasonable cost.

Its construction has been simplified to the greatest degree possible, very complete instructions and blue-prints are ob-

(Continued on page 765)

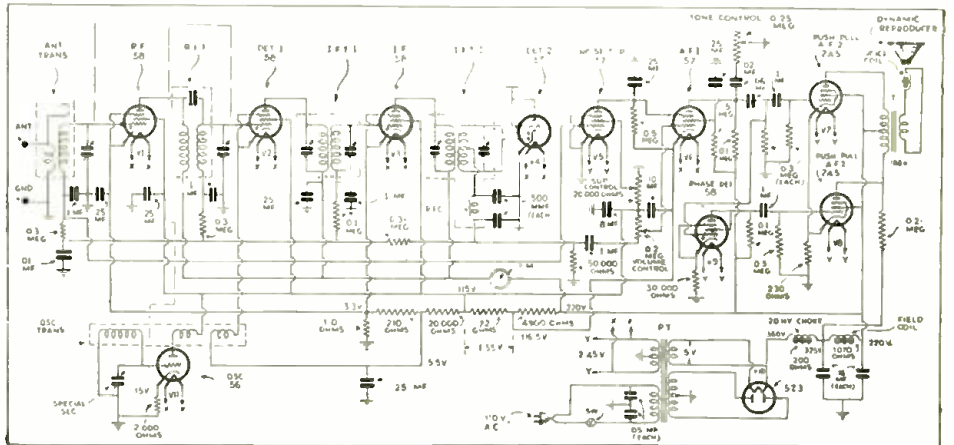

Upper right, Fig. A View of chassis layout and speaker.

Above, Fig. 1 Schematic wiring diagram of 11 tube super.

A 3 TUBE A.C.-D.C. ALL-WAVE PORTABLE

HERMAN COSMAN*

You can take this portable with you on your vacation and receive all short-wave bands in addition to broadcasting. It will work on any 110 volt power supply.



Fig. A
A leatherette case "houses" the set.

THE need for a portable receiver is generally felt by those who leave for parts unknown for their vacation. The uncertainty that exists in regards to the type of power supply that will be available when the vacationer reaches his destination, is pos-

* Chief Engineer, Try-Mo Radio Corp.

sibly the motivating force for not including a radio set along with the rest of his paraphernalia. Of course, a battery-operated portable receiver could be used, but as a rule this type of receiver, with a few exceptions, is exceedingly heavy and cumbersome due to the additional weight and space that is caused by the use of "A" and "B" batteries. Then

again, the continual expense of replacing batteries is a factor that few overlook. Only in cases of rural districts or farmhouses where no power supply is available (or where 32 V. gas-driven generator sets are employed) is consideration ever given to the battery type of receiver.

In designing this set, consideration was given to that large number of short-wave enthusiasts, and so the circuit adopted has flexible features to permit the use of plug-in coils so that reception from 550 to 15 meters may be obtained. A Hartley type of oscillating receiving circuit is employed, thus permitting the attainment of regeneration over the entire wavelength range of the receiver. The sensitivity of the receiver is also increased considerably on broadcast, because of this feature, since in tuning for a station the circuit can be brought into a state of oscillation and the sta-

(Continued on page 743)

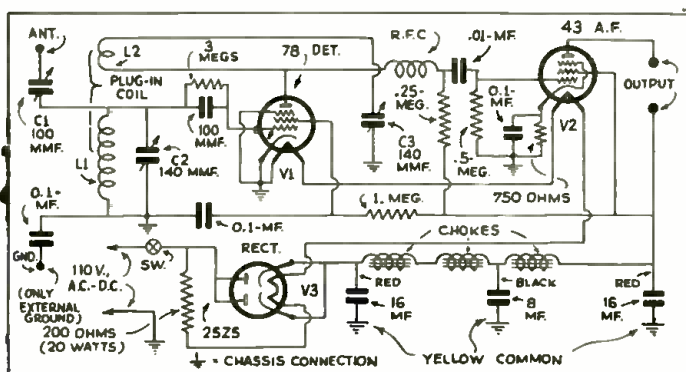
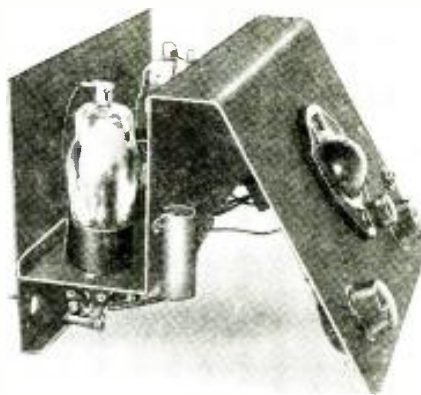

Fig. 1
The schematic wiring diagram of the "All-Wave Portable." Plug-in type coils are employed for selecting various wave bands.

THE "UNI-SHIELDED" SHORT-WAVE THREE

This receiver was designed to bring in those "hard to get" foreign short-wave stations. It employs only three tubes, is operated from batteries, and will receive a great many stations with loudspeaker volume.



Courtesy, Wholesale Radio Co.

WHILE the "Uni-Shielded Short-Wave Three" has been designed especially for the short-wave novice, it is really capable of satisfying the most discriminating short-wave fan. Its outstanding features are high R.F. sensitivity, simplified circuit and mechanical design, smooth regeneration control, ease of tuning, use of low-current drain 2 volt tubes, specially designed short-wave coils, antenna tuning control, all-pentode operation, unusually thorough bypassing, newly developed self-shielded chassis design of high efficiency, and, last but not least low cost. These and other features will be explained in detail in the latter part of this article.

The circuit consists of a stage of R.F., using a type 34 pentode V1, a regenerative detector using a 32 screen-grid V2, and a single A.F. stage using a 33 pentode power output tube V3. Since these three tubes are all 2-volt filament types, the "A" supply of this receiver may be two ordinary bell-ringing type 1½ volt dry cells, an air cell "A" battery, or one cell of a 6 volt storage battery, or any standard storage

(Continued on page 756)

Below: Schematic wiring diagram of receiver.

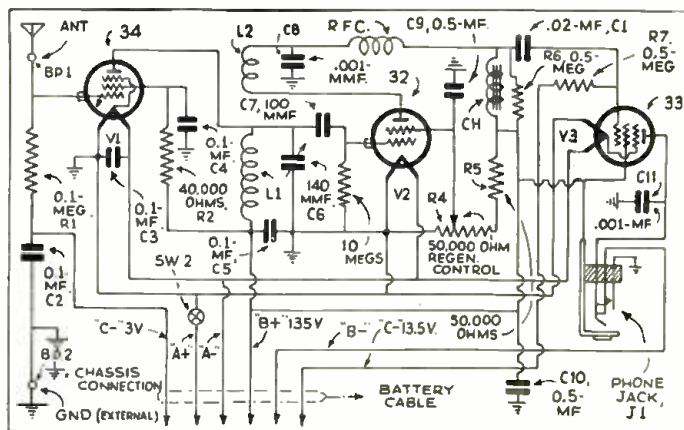

A SHORT-WAVE BOOSTER

This short-wave pre-selector and booster is self-contained and self-powered. It incorporates two stages of tuned radio frequency amplification, for operation in conjunction with any short- or all-wave receiver. It is cleverly constructed, employing completely shielded coils that slide, like drawers, into a compartment in the set.

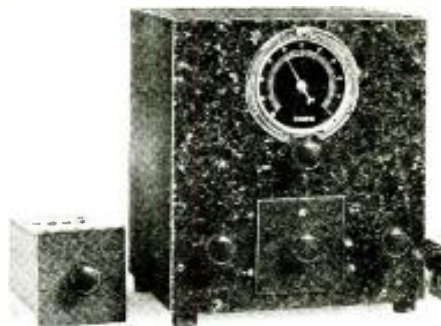

Courtesy, Postal Radio Co.

THIS unit was designed to increase the sensitivity and selectivity of short-wave receivers that were deficient in these qualities. It employs two stages of high gain R.F. amplification, with type 78 tubes having a mu of approximately 1,500. A 25Z5 rectifier

furnishes all the necessary "B" voltage, and the high capacity filter electrolytic condensers are used to insure hum-free reception. This booster unit will operate from 110 V., either A.C. or D.C.

(Continued on page 758)

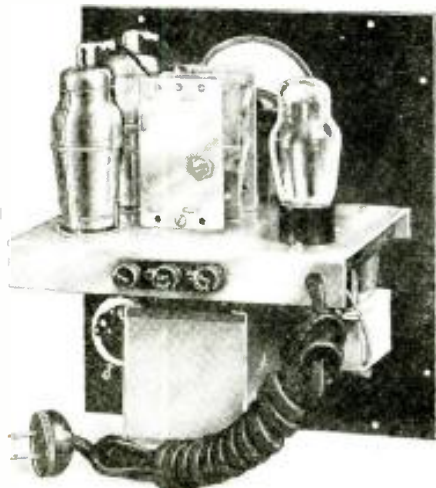
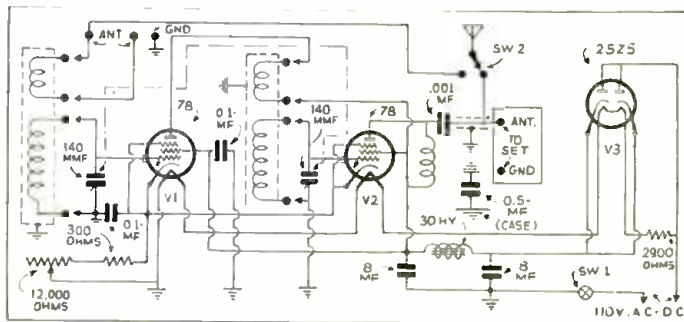

Fig. A. left
This unit will increase the signal strength of short-wave receivers.

Fig. 1. right
Schematic wiring diagram of Booster.



RADIO-CRAFT'S INFORMATION BUREAU

"A 'PERFECTED' 2 TUBE ALL-WAVE SET"

(261) Mr. Frank G. Kohl, Cincinnati, Ohio.

(Q.) On page 523 of the March, 1934, RADIO-CRAFT, there is a diagram of a short-wave set using the 2 V. type 30 tubes.

You give a list of parts but do not refer to the capacities of the fixed condensers or the resistors designated on the diagram as C1, C2, R1, etc. How can you tell which is which?

Radio editors often take too much for granted; they know all parts but the amateur does not. I've wired many a radio set and sometimes had to refer to service manuals.

In the old days most circuits were marked as follows:

- C1—.0025 fixed condenser
- C2—.05 condenser
- R1—50,000 ohm potentiometer

and so on until all the parts were named. It confuses the builder when the parts used are mentioned in the reading matter.

I know the symbols designating the components employed in radio. Would you please supply me with a list of parts as marked in the diagram? I'd like to make this short- and all-wave set.

(A.) Below we are supplying a list of the parts for the set that you are interested in building. If you will refer to the schematic circuit in the March, 1934, RADIO-CRAFT, page 523, you will find the part identification letters that correspond to those in the list.

List of Parts

- One Hammarlund variable condenser, 140 mmf., C1;
- One A.F. transformer, 3 to 1 ratio, T;
- One tuning dial;
- One Centralab potentiometer, 50,000 ohms, R2;
- One 4 wire battery cable;

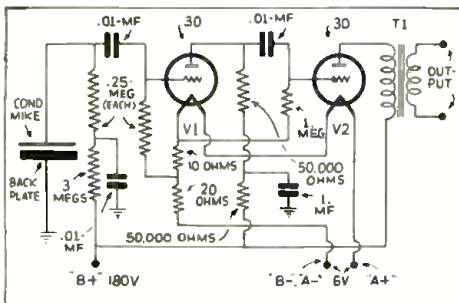

Fig. Q.262, left
The circuit of a typical "head amplifier."

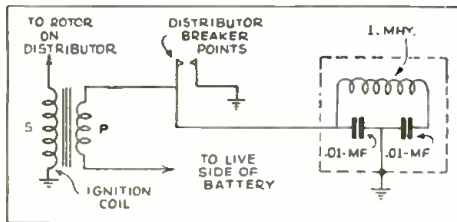

Fig. Q.263, above
Another auto radio noise suppression scheme.

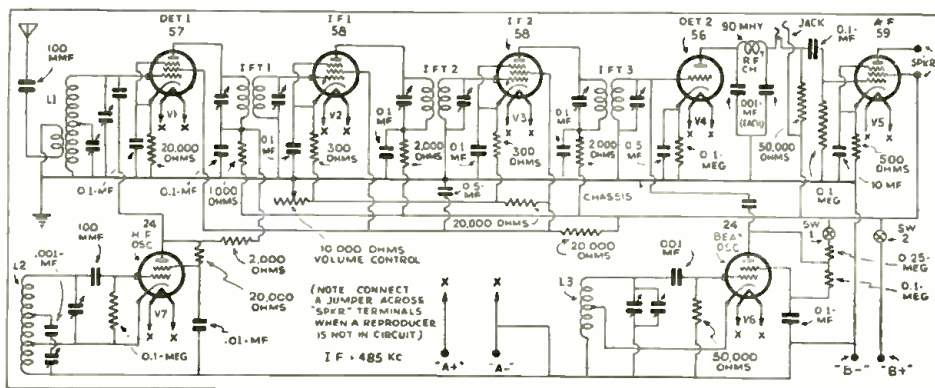

Fig. Q.264
The circuit of the National FB-7 short-wave receiver for bandspreading and continuous band work.

SPECIAL NOTICE

Those questions which are found to represent the greatest general interest will be published here, to the extent that space permits. (At least 5 weeks must elapse between the receipt of a question and the appearance of its answer here.) Mark such inquiries, "For Publication."

Replies, magazines, etc., cannot be sent C.O.D. Back issues of RADIO-CRAFT prior to December, 1932, are available at 50c per copy; except the following issues: 7/29, 2, 3, 4, 6, 9 and 11/30; 5, 8 and 9/31; and 10/32, which are out of print. Succeeding issues are still available at the regular price of 25c per copy.

Inquiries to be answered by mail MUST be accompanied by 25c (stamps) for each separate question; answers are subject to subsequent publication if considered of exceptional interest.

We cannot furnish individual design considerations.

Furnish sufficient information (in reference to magazine articles, be sure to mention issue, page, title, author and figure numbers), and draw a careful diagram (on separate paper) when needed to explain your meaning; use only one side of the paper. List each question. Be SURE to sign your name AND address.

Enclose only a STAMPED and self-addressed envelope for names and addresses of manufacturers; or, in connection with correspondence concerning corrections to articles, as this information is gratis.

carbon type, and for this reason the condenser type cannot be connected directly to a P.A. amplifier which has been used with a carbon unit.

The condenser mike is a high impedance unit, and even if the output was sufficient, it could not be connected to the terminals provided for the carbon mike which is a very low impedance unit (about 40 to 100 ohms). The condenser mike is better suited to connection directly to the grid circuit of a vacuum tube, without a step-down transformer. However, in order to obtain satisfactory service from a condenser mike, it must be "charged" with a high potential and is normally connected to an amplifier in the manner shown in Fig. Q.262. Here, the condenser mike is connected across the 180 V. "B" supply in series with the two resistors, and is coupled through a condenser to isolate the high voltage from the grid of the amplifier tube.

The circuit in Fig. Q.262 is a typical "head amplifier" used with a condenser type mike. It is common practice to include a small amplifier right in the case with the condenser mike, to make up the deficit in output, and also because it is inconvenient to use a high impedance unit at a distance from the amplifier, due to loss in high frequencies and the difficulty in keeping the two connecting wires sufficiently far apart.

The head amplifier can be coupled through a step-down transformer to a transmission line of 200 or 500 ohms and another transformer used at the P.A. amplifier direct, to match this impedance to the input of the P.A. amplifier.

If you intend to use your condenser mike with your portable P.A. system, it will be necessary for you to make or purchase an amplifier of the type shown in Fig. Q.262. The filament and plate supply for the head amplifier can be changed to suit your individual requirements, as you do not state what source of supply you are using. The values of coupling resistors, condensers, etc., will remain the same. The transformer marked T1 should have a primary to match the plate impedance of the 30 type tube and have a secondary of about 200 ohms. A similar transformer with a primary of 200 ohms and a secondary to match the grid circuit of the first tube in your P.A. amplifier should be installed in place of the present microphone transformer.

(Continued on page 752)

READERS' DEPARTMENT

A department in which the reader may exchange thoughts and ideas with other readers.

DOES RADIO SET AFFECT WATER?

Editor, RADIO-CRAFT:

I am sending you a clipping which appeared in the Birmingham Post, February 17, 1934. This might be news to readers of RADIO-CRAFT.

SELMA, Feb. 27—The mystery of Selma's bad-tasting drinking water was solved today, and radio drew the blame.

A state engineer was sent here to ascertain why residents complained of varying flavors, all bad, of their drinking water. The engineer sampled the water at the water works, where he found nothing wrong.

He then made a tour of the residential sections, testing water from hydrants. There were many variations, and he was stumped until he observed a wire leading from a water-pipe to a radio. It was a ground wire and it solved the mystery. Electrical current, the engineer explained, definitely alters the taste of water. It does not affect purity, however. The city council issued orders that no more radios be grounded to water pipes.

R. W. TINES,
Fort Payne, Ala.

This letter brings to light a condition that has been known to radio and electrical engineers for some time. The point is that it is probably not the high-frequency currents which cause the trouble. Many electrically operated receivers have buffer condensers connected across the primary of the power transformer, to reduce the noise picked up in the set through the power lines. Two condensers are usually connected in series across the transformer winding, with the center tap grounded. If the power plug is inserted in the socket in one way, one of the buffer condensers discharges on every half cycle to ground, so that an appreciable current flows from the A.C. line to ground.

This current is sufficient in certain cases to cause electrolysis of the water (that is a breaking down of the water into oxygen and hydrogen) which changes its taste. Also, with certain types of piping, the metal is attacked slightly, which further aids the tainting of the water.

Thus it is not the radio waves which cause the trouble, as suggested by the newspaper clipping.

A BOOST FOR RADIO MONTH IN REVIEW

Editor, RADIO-CRAFT:

Your new section that is appearing in RADIO-CRAFT, called the *Radio Month in*

Service Men who are readers of RADIO-CRAFT will be interested to learn that commencing with this issue, a series of articles pertaining to the merchandising and "mechanics" of their profession will be covered. These subjects, which are of vital importance to the Service Man, will include: *Is Radio a Mechanics' Job?—Should Radio Sets Be Serviced in the Home?—Efforts to Build Business—Servicing in Small Towns, and many others.*

Review. is very interesting and educational to myself as well as to my friends. The "R.M. in R." has given me some knowledge—the knowledge which is impossible to obtain elsewhere. I like it very much, please print more of it.

GEORGE APANA, JR.,
P. O. Box 3345,
Honolulu, T. H.

Thanks for the bouquet, George. We are anxious to hear from any of our readers about the articles that we publish. And we do not mean that all should be compliments, either. If you have any criticism (of the constructive variety) let us hear from you. That's the only way we have of knowing what type of material our readers are interested in.

INTERFERENCE CLUBS, AHOY!

Editor, RADIO-CRAFT:

I wish you would please send me all data in regards to the workings of an interference club as I have several people interested in organizing such a club in the city of Dunsmuir, as the man-made interference this winter has been so bad that radio reception was impossible.

I wish to get in touch with some clubs as to their work and how they may force people to stop noise, as about all we have now is plenty of noise and an ordinance.

C. H. SHUMAKER,
Box 44,
Dunsmuir, Calif.

Unfortunately we do not have the names of any such clubs at hand, Mr. Shumaker. A number were started a few years ago, but they have faded out and at present we do not know of any in active operation.

You ask what can be done to force people to stop making interference in receivers. There are only two ways of practical importance, that we know of.

The first is the use of city ordinances, properly enforced, to make it compulsory for people to shield interfering devices, and place correctly designed filters in the power lines. In this case, the enforcement of a city ordinance is difficult, unless there is some body of radio listeners who are prepared to carry a few test cases to the courts, if necessary, to impress citizens with the fact that they must obey the law.

The other possibility is more remote. If electrical apparatus causes interference with regular radio com-

(Continued on page 760)



A service shop designed by a Canadian Service Man.

ZENITH CHALLENGER MODEL 740 10 TUBE BATTERY-OPERATED SUPERHETERODYNE

(Sensitive and selective. Incorporates A.V.C.; tone control; only 18 ma. no-signal "B" drain; an 8½ in. permanent-magnet type dynamic reproducer; 3 stages of A.F. amplification, including semi-class B output; console cabinet; 9 "standard" tubes and a ballast resistor tube.)



This 10 tube battery-operated superheterodyne incorporates A.V.C., tone control, semi-class B push-push output, and a diode second-detector; the console cabinet, illustrated, houses an 8½ in. permanent-magnet type dynamic reproducer. Tube V10 is a type 10-AB ballast resistor. The "A" is a 2 or 3 V. source; the "B", 135 V.; and "C", a tapped 22.5 V. battery.

Tube socket analysis figures follow: short the antenna to ground, and read voltages to the "A—" filament terminal.

Tube Type	Plate Volts	C.G. Volts	S.G. Volts	Plate Ma.
V1	135	34	65	2.6
V2	135	4.5†	65	2.5
V3	135	4.5†	90	3.0
V4
V5	90	9*	..	1.45
V6	130	9**	..	3.4
V7	135	10.5	..	2.5
V8	135	10.5	..	2.5
V9	90	2 to 4††	..	3.3

(†) Computed; (††) varies with frequency setting; (*) volume control at minimum; (**) as read at battery.

In the diagram, those circuit elements which are shown dotted do not exist as distinct units but occur as a result of the mutual position of other circuit elements or their parts.

Control-grid bias for V1, the type 34 R.F. amplifier, is obtained by a tap between R1 and R2 in the high resistance potentiometer, R11, R1, R2, and R4.

Separate oscillator V9 is tuned by a shaped-plate variable capacitor. This design eliminates the need for a padding condenser—and therefore its occasional adjustment.

The diode second-detector develops across R4 an A.V.C. potential which is applied, through filter resistors R2 and R1, to the grid-return circuits of V1, V2 and V3. Increasing signal strength increases the control-grid voltage applied to these tubes; this reduces the amplification and results

in practically uniform output as set by the manual volume control, R6.

Inoperation of the receiver may be due to one of several reasons. Check for batteries incorrectly connected; battery voltages below par; defective tubes; a tube in the wrong socket; a control-grid cap unconnected; or, a tube shield shorting to the cap of a 34. Also check up the speaker plug; off-on switch; antenna and ground leads, for reversed connections; shorted variable condenser plates; and, open-circuit in transformers.

Low volume may be due to weak batteries, poor tubes, poor antenna system, or mis-alignment of the tuning and I.F. condensers. Check the reproducer and chassis for opens, shorts and grounds.

Circuit oscillation may be due to tubes having incorrect characteristics. A good ground connection is essential. Firmly seat the tube shields. Check bypass condensers for open-circuit; and the tuning condensers for chassis contact. Unit R.F.C. must not short to the chassis.

Distorted reception can usually be traced to defective tubes. However, check batteries for voltage; the reproducer for mal-adjustment; the A.F. transformers. Tune "dead-center" (as necessitated by the A.V.C. action).

Two factors directly affecting the "B" battery consumption, whose normal no-signal drain is 18 ma., are: (1) Signal strength. Weak station signals cause but little A.V.C. action, with resulting high plate current drain by V1, V2 and V3; and (2) A.F. volume. Increasing the A.F. volume increases the "B" drain of V7 and V8.

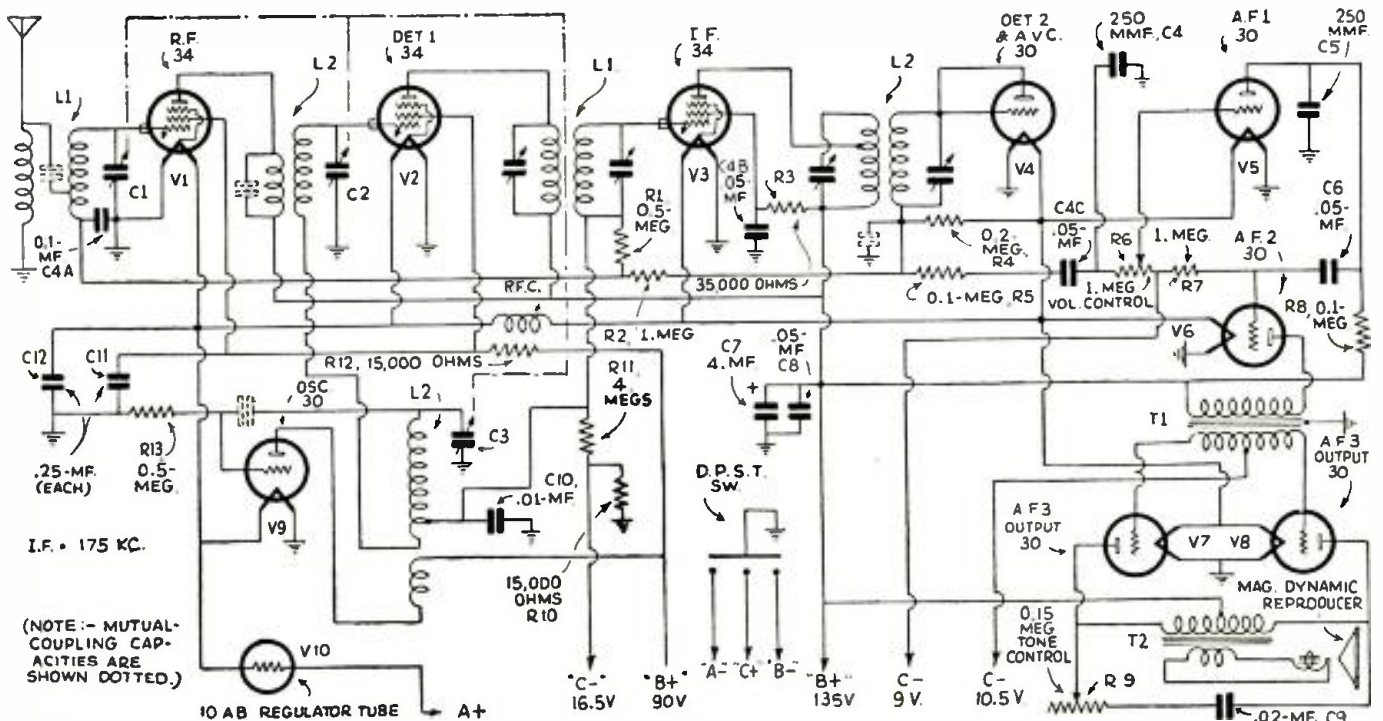



Here's the Quick and Fast Way of Building TEST EQUIPMENT-TEST BENCHES-EXPERIMENTAL LAYOUTS

This new system starts with the New Na-Ald Laboratory Socket. New R.M.A. standard numbering marked at all contact terminals. Has contact which stands up under all kinds of use and abuse. New convenient fitted universal terminals have solder tabs and wide bottom knurled nuts for easily blinding any wire connections. All nuts have jack-toms for receiving the Alden Expanding Pressure-Plug for conveniently changing connections. Plugs may be used even with large based tube in socket. Handy for laboratory work, experimental bread-board set-ups, etc. No holes to bore or special tools required. All holes drilled with hand drill, including those for terminal connections thru chassis.

484—1 hole Lab. Socket.....List Price \$0.50
 485—7 hole Lab. Socket.....List Price .50
 486—8 hole Lab. Socket.....List Price .50
 487—7 lg. hole Lab. Socket.....List Price .50
 487A—7 sm. hole Lab. Socket.....List Price .50

Here are the interchangeable test points used in the Molded Handles. Use the Side-Pressure Plug Point with greatest possible convenience in making socket connections, etc.

Hardened Needle Point for piercing insulated wires, contacting oxidized terminals, etc. Handy hex. grip and 8-32 shank. Silver plated for perfect contact. **No. N Point.....List Price 10c each**

Needle Push-Point for safe-testing. Contacts only when handle is pushed. Protects sensitive meters. Has hex. grip and 8-32 shank. Silver plated for lowest contact resistance. **No. P Point.....List Price 15c each**

Phone Tip Point for any tip jack. Has rounded point for easy use. Has hex. head and 8-32 threaded shank to fit all Molded Handles. Polished nickel plated finish. **No. T Point.....List Price 5c each**

Expanding Side-Pressure Point for NaAld Jacks, Lab. Socket terminals, small socket holes and any 1/4" hole. Very handy for point-to-point testing, etc. Silver plated for perfect contact. **No. S Point.....List price 10c each**

Double-Circuit Point for use with Na-Ald Series Jack. Handy for making current tests with point-to-point analyzers. Tests both current and voltage from same jack. Fine for modernizing old analyzers and making compact testers. Silver contacts. **No. D Point.....List Price 20c each**

MOLDED HANDLES

Any handle below takes any of above 5 interchangeable points. Wire solders or binds on removable eyelet in molded handle. Points screw up against eyelet insulating firm contact.

Two piece Molded Test Prod Handle. Hollow top unscrews and holds spare points. Wire lead out of way reduces hand capacity in Neon lamp and high frequency tests. Also insures protection in high voltage testing. Wire may be brought through top if desired. Removing handle provides short length test prod for restricted spaces. Rugged moldings with high finish give beautiful appearance of highest quality. 8-32 thread takes any of above points. **No. 110—Two Piece Molded Test Prod Handle.....List 40c each**

Molded Test Panel Handle. Handy for point-to-point testing on panels. Wire brought out through side hole. Threaded top takes test prod handle as well as regular panels from 1/32" to 1/8" contact jacks for banding off connections with pressure plug points. Bottom takes any style 8-32 point shown above. **No. 111—Molded Test Panel Handle.....List 20c each**

Molded Small Space Handle. Fine for point-to-point testing and all compact test equipment. Wire lead brought out through top. Bottom take 8-32 threaded shank points shown above. **No. 112 Molded Small Space Handle.....List 10c each**

Molded Finger Grip Handle. Wire brought out perpendicular to plug. For experimental socket connections, vertical panel connections, etc. Receives any 8-32 point as described above, which binds against bare wire. **No. 113—Molded Finger Grip Handle.....List 15c each**

MOLDED JACKS

Attractive Round Molded Head Jack for Na-Ald Expanding Pressure Plug. Requires 1/4" hole for mounting. Has self-centering insulated shank for use in metal as well as regular panels from 1/32" to 1/8". Supplied with insulated washer, solder tab and hex. nut, also ten assorted printed and blank tabs for identifying Jack.

No. 100-JR—Pressure Plug Molded Jack (Black).....List 15c each complete

Attractive Round Molded Head Tip Jack. Requires only 1/4" hole for mounting in any panel. Insulated rim centers Jack in all panels up to 1/4". Supplied with nut and insulated washer, also blank marking tabs for identifying Jack.

No. 101-J—Phone Tip Molded Jack (Black).....List 15c each complete

No. 101-JR—Phone Tip Molded Jack (Red).....List 15c each complete

Attractive Round Molded Head Circuit Opening Jack. Requires only 3/8" hole for mounting in any panel. Molded insulation centers Jack in metal panels. Very handy for point-to-point testers enabling both current and voltage tests to be made with only one Jack in each circuit. Takes Type D point for current and Type S point for voltage tests. Jack circuit normally closed, but opens when D point is inserted. Supplied complete with blank identification tabs, insulated washer, solder tab and nut. **No. 102-J—Circuit Opening Molded Jack (Black).....List 35c each complete**

No. 102-JR—Circuit Opening Molded Jack (Red).....List 35c each complete

Attractive Round Molded Head Double Circuit Jack. Requires only 1/2" hole for mounting in any panel. Molded insulation centers Jack in metal panels. Uses Na-Ald "D" point for connecting together two circuits. Handy for speakers, small lamps, voltage supplies, etc., wherever two circuits are to be connected. Supplied complete with 10 printed and blank identification tabs, insulated washer, solder tab and nut. **No. 103-J—Double Circuit Molded Jack (Black).....List 35c each complete**

No. 103-JR—Double Circuit Molded Jack (Red).....List 35c each complete

Connects together two Na-Ald Pressure plugs for extending leads, etc. Molded insulation covers entire length of connector. **No. 140—Pressure Plug Thru-Connector.....List 15c each**

Connects together two standard phone-tips for extending leads, etc. Entirely insulated with molded insulation. **No. 141—Phone Tip Thru-Connector.....List 30c each**

Pressure plug, multiple connector for routing two, three or four pressure plugs together. Entirely insulated. Handy for quick connections of experimental apparatus. **No. 142—Pressure Plug Multiple Connector.....List 35c each**

Phone tip multiple connector for coupling two, three or four phone tipped leads together. All molded insulation. Useful for quick set-ups. **No. 143—Phone Tip Multiple Connector.....List 45c each**

New Self Mounting Socket gives manufactured precision appearance to any set. This socket screws in place with a 1/2 turn in a 1-1/16" hole. Threads engage two projections in hole easily made with prick punch. Easy to assemble. No screws, nuts, rivets, springs, clamps or other material necessary. Has long surface balls for low losses and high insulation. New R.M.A. standard numbering system on all sockets above and below panel. Neat filament prong locator with color dot. Tube number ring on top of socket. **No. 404—4 hole Self Mount Socket.....List 10c**
No. 405—5 hole Self Mount Socket.....List 10c
No. 406—6 hole Self Mount Socket.....List 10c
No. 407A—7 hole Self Mount Socket.....List 10c

Here is the solderless connector terminal which fastens securely to the end of a wire by simply pinching it with a pair of pliers. It takes the Na-Ald Expanding Pressure Plug for making up handy experimental set-up leads of any length. **No. 131—Solderless Jack Connector.....List 2 for 5c**

This is the solderless expanding pressure plug terminal which fastens to lead wires by simply pinching with pliers. Allows convenient jumpers to be made up quickly for all kinds of test and experimental work. **No. 130—Solderless Plug Connector.....List Price 2 for 5c**

Screw Clamp Terminal Connector. Slips onto Alden Pressure Plug terminal changing to solder tab connector. Has binding screw for securely attaching to any flat terminal so that pressure-plug terminated leads may be conveniently attached without soldering. **No. 170—Flat Terminal Connector.....List 15c each**

Phone Tip Adapter. Adapter to change Expansion Pressure Plug terminal to phone-tip terminal. Jack end receives pressure plug, other end forming phone-tip terminal. **No. 171—Pressure-Plug to Phone-Tip Adapter. List 1c ea.**

Spade Terminal Connector. Slips onto Alden Pressure Plug terminal changing to spade terminal. Fits 8-32 screws and smaller so that pressure plugs may be easily attached to binding posts, etc. **No. 172—Spade Terminal Connector.....List 15c each**

Jack-Top Binding Post. Handy for making up test panels. Wire may be soldered to lug or bound under head. Knurled nut has wide bottom for easily blinding wire and also receives the Alden Pressure Plug in Jack-top. **No. 180—Jack-Top Binding Post.....List 2 for 5c**

Insulated Tube Cap Leads. Neat molded insulated clips for all tube caps. Has newly developed contact clip giving perfect connection without sticking. Twelve-inch lead supplied ready connected. Wire insulated for protection against shock. **No. 91-L—For all receiving tube caps.....List 20c**

No. 92-L—For 866, 872, etc., lg. tube caps.....List 35c

DeLuxe Dial. Here is the finest looking dial. Fine for general purpose work. Has 3/4" shaft hole and available in 2" or 3" diameter. 0-100 degree graduations. 5" Model shown supplied with vernier plate for precision recording to five hundredths of one per cent of a turn. Fine for capacity bridges, frequency meters, etc. **No. 3034—3" dial 3/4" shaft hole.....List 30c**
No. 3044—4" dial 3/4" shaft hole.....List 50c
No. 3054—5" dial with vernier plate.....List \$1.00

CANDELABRA SERIES AND STRAIGHT PLUGS



Continuity Tester plugs in any outlet A.C. or D.C. Takes candelabra based Neon or filament lamp for high or low resistance series testing. Special protective resistor permits use of low priced Neon lamps without resistor as well as others with resistors. Also limits current so that either test lead may be safely touched to ground, even continuously. Shorts or leakages up to 1,000,000 ohms may be detected with the use of a Neon lamp. Fine for condensers, chokes, resistors, etc. Also handy for occasional household and industrial tests on appliances, cords, etc. **Na-Ald No. 160—Candelabra Series Plug without leads.....List 35c each**

Na-Ald No. 161—With Na-Ald DeLuxe Test Prods.....List \$1.50 each

Na-Ald No. 162 consists of No. 161 complete with neon lamp in illustrated box with extra tips, etc. **List \$2.00 each**

Candelabra Base Plug takes candelabra based Neon or filament lamps. With Neon lamp tests polarity of outlet. Also useful as a handy outlet light, night lamp, pilot light, location marker, current indicator, decorative lamp, etc. **Na-Ald No. 163—Candelabra Base Plug.....List 25c each**

SPEAKER-PHONES SWITCHING ADAPTER

For use with any pentode output tube. Permits independent use of speaker or phones by flipping toggle switch, phones and adapter remaining connected. No wiring necessary. **No. 955-PSC** For single 5-prong PENTODES such as 6A4, 33, 47, 257, KR-5, LA, P-5 or PZ.....List Price 2.50

No. 955-PSW For push-pull 5 prong PENTODES such as above.....List Price \$3.00

No. 966-PSC For single 6-prong PENTODES such as 2A5, 18, 41, 42, 43, 48, 95, AE, KR-25 or PA.....List Price \$2.50

No. 966-PSW For push-pull 6-prong PENTODES such as above.....List Price \$3.00

Why be handicapped with an ancient analyzer when in two hours you can easily modernize with one of these kits and a pair of composite sockets? Directions and diagrams included with all outfits.

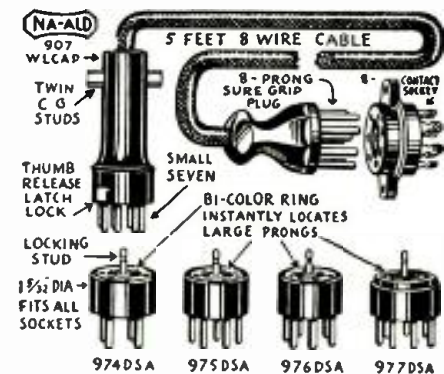

907-WLCAP—Small 7 prong Latch Lock Analyzer Plug, 8-wire Cable, Plug and Socket as shown List above \$6.00

974-D5A—Latch 7 to 4 prong Adapter.....List 1.25
975-D5A—Latch 7 to 5 prong Adapter.....List 1.25
976-D5A—Latch 7 to 6 prong Adapter.....List 1.25
977-D5A—Latch 7 to 7 prong large Adapter.....List 1.25

FREE—Send for catalog and give the name and address of your dealer or jobber. You will be mailed without cost a sample laboratory socket and pressure clips if you mail your letter on or before June 15th.

NA-ALD items are widely stocked—try your regular supplier—if he hasn't them and doesn't care to get genuine Na-Ald Products, order direct from us. Discount 35—40% if order totals \$10.00 list price.



ALDEN PRODUCTS CO.
 Dept. R-6, 715 Center St.
 BROCKTON, MASS.



CLARION 5 TUBE MODEL 423; 6 TUBE 470, 471 and 472; AND 10 TUBE 480

(Model 422 A.C.-D.C. superhet.—126 channels; built-in antenna. Model 470 superhet.—246 channels; built-in antenna; tone control; A.V.C. Model 480—296 channels; neon tuning indicator & noise suppressor; A.V.C.; tone control; A.F. compensation; noise control; class B A.F.

Socket analysis readings are read with volume control full on; line voltages: 422, 10 V.; 470, 109 V.; 480, 110 V. For 422 chassis, (*) under V1, refers to the detector section; (**) the oscillator.

Clarion 423 (422 chassis)

A 5 tube A.C.-D.C. superhet., with built-in antenna.

Tube Type	Fil. V.	Pl. V.	C.G. V.	Cath. V.	S.-G. V.	Pl. Ma.
*V1	48	80	2.5	15	35	0.6
**V1	..	77	0.2	1.8
V2	7	72	2.3	13	75	..
V3	6	28	0.9	13	0.3	..
V4	24	78	0.3	13	82	..
V5	24	90	..	90

The sup.-G. voltage of V2 is 0; V3, 0.8V.

Clarion 470, 471 and 472

A 6 tube superhet. Has A.V.C., tone control, and self-contained antenna.

Tube Type	Fil. V.	Pl. V.	C.G. V.	Cath. V.	S.-G. V.	Pl. Ma.
V1	2.1	235	0.4	7	80	2.7
V2	2.1	95	0.6	0	..	5
V3	2.1	243	0.3	2.2	85	6
V4	2.1	140	4	1.1	0.1	0.2
V5	2.1	235	0.5	240	..	24
V6	4.7	328	24

Clarion 480

A 10 tube superhet. Has A.V.C., tone control, neon tuning with inter-station noise suppression, noise-level control, base-note compensation, and push-push class B output.

Tube Type	Fil. V.	Pl. V.	C.G. V.	Cath. V.	S.-G. V.	Pl. Ma.
V1	1.9	180	0.2	2	72	3.7
V2	1.9	230	1.2	6.5	100	2.6
V3	1.9	105	0.1	0	..	5.5
V4	1.9	180	0.2	2	72	3.5
V5	1.9	0	0.3	0	..	0
V6	1.9	103	0.1	42	..	1.3
V7	2.1	190	3.5	19	190	16.5
V8	2.1	350	0	108	350	7
V9	2.1	250	0	108	350	7
V10	3.5	390	43

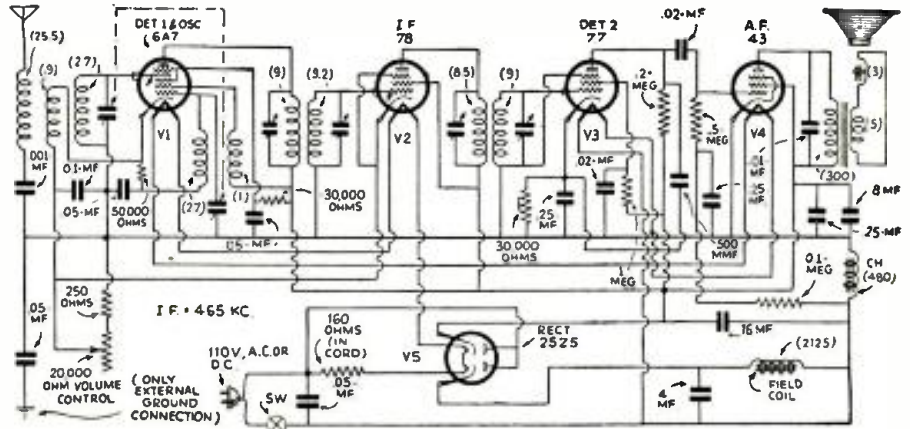

Clarion model 422 chassis; frequency range, 540 to 1,800 kc.

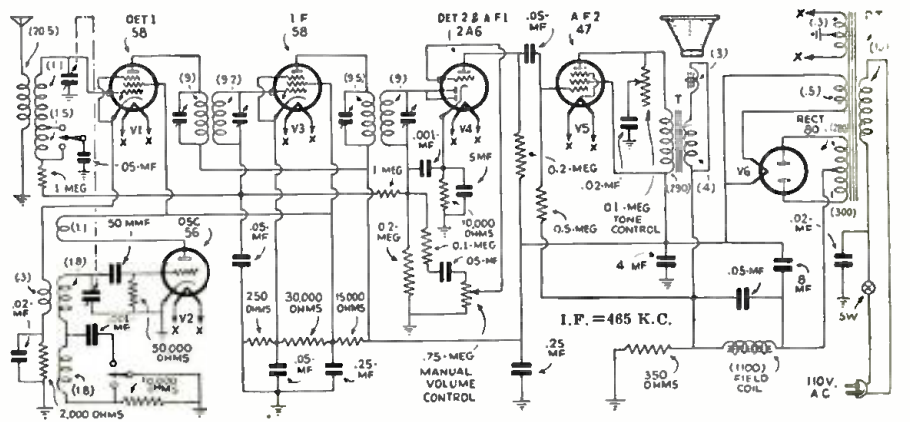

Above, Clarion model 470 chassis; frequency range, 540 to 3,000 kc. used in models 470, 471 and 472 sets. Below, Clarion model 480 chassis; frequency range, 540 to 3,500 kc.

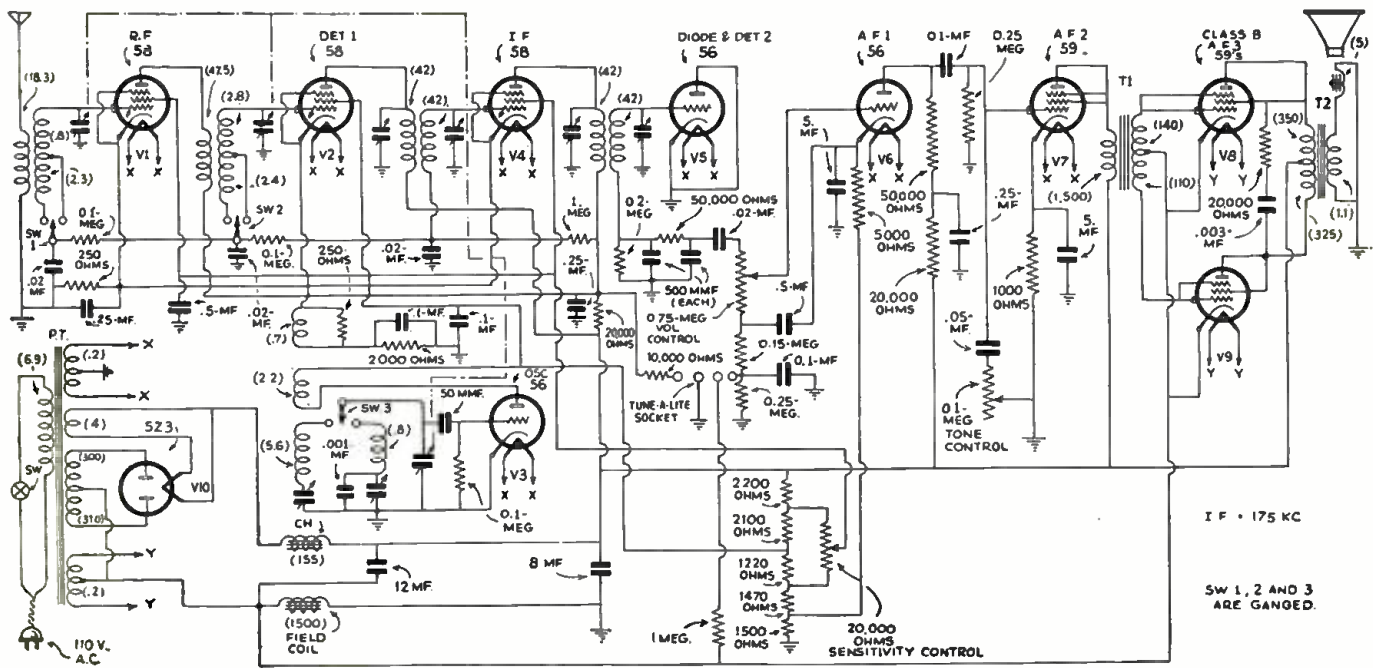

AMPLIFIED CHIMES

(Continued from page 719)

pressing another button, still another combination of notes can be obtained. By substituting an accurate clock with switch contacts that are operated quarterly, half-hourly, or hourly, these chime combinations may be made to occur at respective intervals to announce time differences.

The solenoid plungers are padded with leather so as to avoid obtaining sharp, ringing, metallic notes. The chimes are suspended by strings or heavy cords from supports above each solenoid plunger opening. These supports may be plainly seen in Fig. 6. The electrical connections to and within this "control box" which, incidentally, is operated by an A.C. step-down transformer, 110 V. to 16 V., are shown in Fig. 1. This includes all necessary connections to a terminal strip which in turn is connected to a 5 prong plug receptacle for accommodating the keyboard cable plug; and also, additional single-button connections for either single chime tones or combinations of tones and notes, the latter being indicated by that button to which Nos. 6 and 8 wires connect. It is also possible to work out various other chime combinations which may be obtained by pressing a single button. It is not necessary to keep a button depressed until the series of notes are obtained, since a relay which can be seen in Figs. 1 and F operates in conjunction with the commutator and automatically starts and stops the motor.

The experimental and test chime outfit which we built is shown in Fig. A. A "grandfather clock" type radio cabinet was employed for housing all of the necessary mechanisms. Only 4 chimes were used in this particular model in connection with a 4 note keyboard, and it will be found that a considerable number of melodies are possible with this number of notes. However, where desired, it is entirely possible to secure any number of chimes, so that elaborate sheet music can be played. An illustration of the standard types of chime assemblies which are now commercially available are shown in Fig. B; a rear view of the 4 note mechanism is Fig. C.

Amplifier Output

Where considerable volume is desired, the size or power output of the amplifier must be of a high order. It is recommended that where a power output in excess of 25 W. is to be employed, the amplifier be built into two separate units; one, the voltage amplifier which should be placed as close to microphone and chime arrangement as is possible; second, the power amplifier which, for best results and maximum efficiency, must be placed as close to the loudspeakers as possible. (For rules and theory concerning P.A. installation Installation and Service," by the author.) The sequence and connections for this set-up are shown in Figs. C, D, E and F.

Concerning the number of horns that should be used: this is dependent upon the distribution of sound that is desired or which may be necessary. Where belfry installations are to be made, 4 large trumpet horns will be found most practical.

Conclusion

Essentially, the point to be emphasized is that the use of chimes can be employed either for "dressing-up" a P.A. installation, or as an efficient substitute for more expensive and elaborate musical instruments. In addition to the suggested applications in this article, the installation engineer may, by his ingenuity, find other uses, such as in homes (in conjunction with the audio amplifier section of a radio set, if considerable volume is desired) where the amplified chimes may be actuated by door bells, electric clocks, servant calling systems, etc.

In very large installations, where the chime requirements are non-standard and require more notes than are shown in Fig. B, specifications should first be submitted to the manufacturer. For other data, concerning the amplifying equipment, the reader is referred to the book, "P.A. Installation and Service" which should help to overcome problems that are encountered in this respect.

GEORGE BURNS
and
GRACIE ALLEN
win a new listener
—and get a tip on
real radio enjoyment

AT REHEARSAL

2

OH GEORGE—
GEORGE, THE
STRANGEST THING
HAPPENED TO ME
JUST NOW.

SOMEBODY TOLD
YOU HE ADMIRED
YOUR BRAINS,
I SUPPOSE.

3

YOU WILTED?
NOW GRACIE, DON'T
TELL ME HE THINKS
YOU'RE A LITTLE
VIOLET. YOU FADED,
YOU MEAN.

OF COURSE NOT,
SILLY. HE SAID
HE COULDN'T
HEAR ME ON THE
RADIO, BECAUSE
I WILTED SO.

FADED—WILTED...
WILTED—FADED...
WHAT'S THE DIFFERENCE? I THINK
THE MAN'S JUST
CRAZY, ANYWAY.

FOR ONCE, GRACIE,
YOU'RE RIGHT. HE'S
CRAZY TO SAY THAT
YOUR VOICE FADES.
I'LL BET IT'S HIS
RADIO TUBES.

4 NEXT REHEARSAL

OH GEORGE, I'M SO NERVOUS. I MAY WILT—FADE, I MEAN—THE WAY THE MAN SAID. OOOH, LOOK... HERE HE IS NOW.

PARDON ME, IS THIS THE BURNS AND ALLEN REHEARSAL? I WANT TO APOLOGIZE TO GRACIE FOR SAYING HER VOICE FADED.

5

IT WASN'T YOUR VOICE—IT WAS MY OLD TUBES. I JUST GOT A WHOLE NEW SET OF RCA MICRO-SENSITIVE RADIO TUBES. NOW I HEAR EVERYTHING.

OOH, GOODY—NOW IT WON'T SOUND AS IF I FILT—WADE, I MEAN.

FOR BETTER RADIO TONE —NEW TUBES BY RCA

NOW you can get more *real* pleasure out of radio! These new Micro-Sensitive RCA Radio Tubes bring 5 great improvements to your set. Replace worn tubes with these amazing new ones—only tubes guaranteed by RCA Radiotron Co., Inc. Have your dealer test your tubes today.



MICRO-SENSITIVE RADIO TUBES GIVE YOU 5 IMPROVEMENTS

- 1 Quicker Start
- 2 Quieter Operation
- 3 Uniform Volume
- 4 Uniform Performance
- 5 Every Tube is Matched

Lunningham Radiotron

AMERICA TURNS TO MIDWEST!



AMAZING NEW

Super Deluxe

16-TUBE ALL-WAVE RADIO



9 TO 2,000 METERS

13 MEGACYCLES TO 150 KC WORLD-WIDE RECEPTION

BEFORE you buy any radio, write for big new FREE Midwest catalog printed in four colors. It has helped thousands of satisfied customers save from 1/3 to 1/2 on their radios by buying direct from the Midwest Laboratories. You, too, can make a positive saving of from 30% to 50% by buying a Midwest 16-Tube Super Deluxe ALL-WAVE radio at sensationally low direct-from-laboratory prices. They bring in broadcasts from stations 10,000 miles and more away and give complete wave length coverage of 9 to 2,000 meters (45 megacycles to 150 KC). These bigger, better, more powerful, clearer toned, super-selective radios have FIVE distinct wave bands—Ultra-short, short, medium, broadcast and long—putting the whole world of radio at your finger tips. Now listen in on all U.S. programs, Canadian, police, amateur, commercial, airplane, and ship broadcasts. Try this Midwest radio for 30 days before you decide. New four-color catalog pictures a complete line of beautiful, artistic consoles and sets. See for yourself the 40 new 1934 features that insure amazing performance. These features include Automatic Select-O-Tune, Amplified Automatic Volume Control, 16 New Type Tubes, Balanced Unit Superheterodyne Circuit, Automatic Tone Compensation, 29 Tuned Circuits, 7 KC Selectivity, etc. These and many additional features are usually found only in sets selling from \$100 to \$150! Write for FREE catalog.

\$49.50 NEW LOW PRICE

WITH NEW DELUXE AUDIOTORIUM TYPE SPEAKER

(less tubes) TERMS AS LOW AS \$3.00 DOWN

DEAL DIRECT WITH LABORATORIES

Increasing costs are sure to result in higher radio prices soon. Buy before the big advance—NOW—while you can take advantage of Midwest's amazingly low prices. No middlemen's profits to pay. You save from 30% to 50% when you buy direct from Midwest Laboratories—as little as \$5 down plus a Midwest radio in your home. Satisfaction guaranteed or your money back.

SAVE UP TO 50%

FREE 4-COLOR CATALOG

SAVE 50%

Midwest Radio Corp., Est. 1930, Dept. 517, Cincinnati, O., U.S.A. Cable Address: Miraco, A.B.C. 5th Edition

RUSH THIS COUPON FOR AMAZING 30-DAY FREE TRIAL OFFER AND NEW 1934 CATALOG

MIDWEST RADIO CORP., Dept. 517 Cincinnati, Ohio.

Without obligation on my part send me your new FREE 1934 catalog, and complete details of your liberal 30-day FREE trial offer. This is NOT an order.

Name _____

Address _____

City _____ State _____

AGENTS! Make Easy Extra Money Check Here for Details

INTERNATIONAL RADIO REVIEW

(Continued from page 715)

NINE PIN TUBE SOCKET

DURING the past year, ever since tube manufacturers started their rampage of new tube developments, radio Service Men, dealers and experimenters have been expecting and in some cases dreading the inevitable 8 and 9 prong tubes (the dread being caused, of course, by the contemplated changes necessary in testing equipment to accommodate these tubes).

It appears now that English radio manufacturers have beat us to it, as a recent issue of WIRELESS WORLD contained the photo shown in Fig. E, of a new socket, just placed on the market to accommodate 9 prong tubes.

BIFOCAL TUNING

IN RECENT issues of English magazines, particularly POPULAR WIRELESS, a system of tuning, known as Bifocal Tuning, has been given unusual display.

The system is an outcome of the Lucerne Wavelength Conference at which practically all broadcast stations were given new wavelength assignments. The result has been rather disappointing to many listeners according to reports in European magazines, and as an answer to the chaos of interfering stations heard in sets not having the required degree of selectivity—this new tuning scheme was devised.

It depends mainly on a newly developed coil, shown in Fig. F, which consists of two inductances with a small moving high-frequency iron core. The core metal is probably one of the metal-dust types that we have mentioned previously in these columns.

The placement of the coils with respect to the coils and the size of the core has been worked out so that changes in the position of the core pieces does not have any effect on the self-inductance of the two coils. But when the core is withdrawn from the coils, by pushing the knob in, the mutual induction between the coils is reduced.

This variation permits the operator to adjust the apparent selectivity of the set at will and without the necessity for realigning the tuned circuits every time the core is touched.

If the relation between self-inductance of the coils and mutual induction between them has been worked out as perfectly as the descriptions would have one believe, this new system should produce very flexible control for a set (to suit local conditions).

NEW LUCERNE COILS

THE recent changes in assigned frequencies for broadcast stations in Europe have necessitated many listeners to either buy new receivers or change their present sets, in order to hear stations over the entire broadcast bands. The band corresponding to our broadcast band now covers from 150 to 550 meters and the additional long-wave band used in Europe for broadcasting now covers 850 to 1,350 meters.

To cover the extended "medium" wave band necessitates coils of high quality with extremely low inter-turn capacity, and condensers with unusually low minimum capacity values.

To satisfy the needs of listeners, coil manufacturers in England have brought out new coils especially designed to cover the above wavelengths, for replacement in existing sets and for use in newly constructed receivers. One of these coils is pictured in Fig. G.

LATEST IN RADIO

(Continued from page 717)

The center-tap resistor shown at B measures only 1 1/2 x 1/8 x 3/8-in. in width. These resistors are color-coded for values between 10 ohms and 200 ohms; the center-tap is accurate to plus or minus 1%.

These precision type resistors should find many uses in the construction of units requiring accuracy, such as testing instruments, bridge circuits and resistance banks.

A TUBE PULLER (No. 461)

A 36 IN. length of dlat cable loops around the tube to be pulled out of its socket, and is doubled back through an 8 in. length of bakelite tubing.

A DRY-DISC DETECTOR (No. 462)

AN AMERICAN design of dry-disc detector, wheatstone-bridge connected. This type of fixed detector is especially suited to use as the second-detector in superheterodyne receivers, since it is not "sensitive," but requires a high input power level.

The use of dry-disc rectifiers is illustrated in Fig. 6, in the International Radio Review department of the March, 1934, issue of RADIO-CRAFT; also, in Fig. 3, in the same department of the October, 1933, issue; bridge-connections are shown on pg. 39, in the Information Bureau of the July, 1933, issue.

BATTERY-TYPE BALLAST (No. 463)

A BALLAST resistor has been developed for use in place of fixed or variable resistors, for regulating the voltage applied to 2 V. tubes; as the supply voltage (from dry cells or a storage battery) gradually drops, the ballast resistor by automatically changing in value tends to maintain a filament terminal potential of 2 V.

Ballast resistors of various values are available to meet individual current drain requirements.

WATERPROOF CEMENT (No. 464)

A handy cement which finds many uses in radio repair work is shown below. It is waterproof, strong and best of all it has high insulating qualities. A few of the possible uses are—for repairing the flange of dynamic-speaker cones, re-centering voice coils, making R.F. coils self supporting, impregnating coils and condensers, insulating wires, repairing cabinets, etc.

The cement is supplied in small cans with a brush, and similar cans of thinner for the cement are available.

SHORT-WAVE COILS (No. 465)

Coils for short-wave reception are available from one manufacturer in three different styles as illustrated below. The left coil is wound on a ribbed bakelite form; the center one on a small cylindrical bakelite form; and the right one on ribbed "Insulex" (a particularly efficient insulator for short-wave use). Coil kits are available from this source for practically every circuit published.



Handy repair cement and thinner. (No. 464)

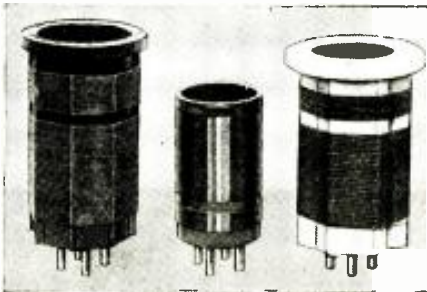

Three types of S.W. coils. (No. 465)

ALL-WAVE PORTABLE

(Continued from page 734)

tion's carrier wave thus more readily identified.

By referring to the circuit diagram, shown in Fig. 1, it can be seen that the plug-in coil consists of two windings, L1 and L2. Condenser C1 is connected in series with the antenna so that an aerial that was normally erected for broadcast reception may be adapted to short-wave reception. It is imperative that this tuning unit be given serious consideration when tuning on the lower wavelengths, if proper results are desired. Regeneration is controlled by condenser C3.

Three tubes are all this set uses, a 77, 43 (audio stage), and a 25Z5 as a half-wave rectifier. The output terminals may be connected to either a magnetic type loudspeaker or headphones, the latter being preferable where short-wave reception is concerned. The filaments or heaters of these tubes are wired in series, so if at any time the tubes do not light the trouble might be just in one defective (open filament) tube. The audio stage is of the resistance coupled type, thus providing good quality output at low cost.

The receiver will operate on either A.C. (any number of cycles) or D.C. On the latter, precautions should be taken that the plug is inserted in the light socket properly, since the set will operate with the plug in only one way.

Constructional Details

In assembling the various material it must be remembered that due to the small dimensions of the carrying case not all of the parts can be mounted on the panel. The depth of the case is approximately only four inches, which means that the material must be so arranged that those on the panel and on the inside bottom of the case do not conflict. If these precautions are not taken it will be found that the panel will not go into the grooves that are provided for it on the case. The particular model shown in Fig. A has the three chokes and an electrolytic block mounted on the bottom of the case, arranged in one corner so that they do not interfere with any of the parts on the panel. All of the remaining items can be easily mounted on the inside face of the panel. A few holes of approximately one-half inch in diameter should be drilled in the bottom of the case to permit dissipation of heat that is generated by the chokes and resistor which is included for obtaining the necessary voltage drop from 110 volts to the voltage required for heating the tubes.

Due to the depth of the cover it is possible to arrange the four or five coils and three tubes so that they are contained within the case when the set is being carried around. The entire weight of this receiver, with coils and tubes, does not exceed 20 pounds.

List of Parts

One portable carrying case;
One drilled panel;
Two variable condensers, 140 mmf., C2 and C3;
One variable condenser, 100 mmf., C1;
Two vernier type dials;
One "on-off" switch;
One knob;
Two binding post sets;
One 4-prong coil socket for L1 and L2;
One 78 socket, V1;
One 43 socket, V2;
One 25Z5 socket, V3;
One tube shield for V1;
One screen-grid clip;
Three Powertest filter chokes;
One Powertest electrolytic condenser block;
One 100 mmf. fixed condenser;
One .01-mf. fixed condenser;
Three .1-mf. fixed condensers;
One 85 mh. R.F. choke;
One 3 meg. resistor;
One .25-meg. resistor;
One .5-meg. resistor;
One 1 meg. resistor;
One 750 ohm resistor;
One 200 ohm resistor, 20 watts;
One set of 4 plug-in coils (15-200 meters, broadcast coil extra);
Miscellaneous items, such as hardware, hook-up wire, etc.

5,000 REASONS WHY

The 5,000 of the world's best radio technicians who have discarded their old time testers for the No. 333 Analyzer can't be wrong! What better guarantee of satisfaction can you have than the endorsement of 5,000 skilled users in your own profession—5,000 men who know from experience that there isn't an instrument, even at 50% or 60% higher cost that can do what the No. 333 will do—that gives the range, speed, flexibility, and exclusive advantages of the "Free Reference Point System of Analysis."*

Check the Model No. 85—find any tube tester that will tell you as much—that will give an individual leakage test between each and every element of every tube, instantly disclosing the faults of troublesome tubes that test "Good" on ordinary testers. As many tubes require replacement because of noisy operation resulting from internal leakages as for any other reason. These tubes will not generally perform satisfactorily in a radio, but will test "Good" on ordinary testers. *They can be detected only by the leakage test of the Model 85.* This instrument will positively amaze you.

The Model No. 35 in its price class is equally sensational in what it gives for the money in simplicity of operation and completeness. Directly indicates good and bad tubes, based on accurate calibration. Developed under the guidance of the leading tube engineers and proven under actual daily service conditions. Prominent English reading scale directly indicating the true quality of all tubes.

The radio serviceman is at the mercy of his tools, which are his testing instruments. He can't let instruments that haven't kept pace with radio progress slow him up. He can't afford not to know about new developments that reduce his labor, increase his efficiency, and make every day a bigger dollar producer.

That's why every radio serviceman needs to know about the 3 new Supreme instruments pictured on this page. No matter when you plan to buy, you must be informed of the new engineering standards established by Supreme engineers who have constantly made good with the popular tribute, "Supreme by Comparison." These instruments are offered you in the confidence that they are the 3 best engineered instruments brought to the radio service world to date.



Dealers Net Cash
Wholesale Price
\$39.50

See these sensational instruments at your jobbers. Be sure also and send for the complete descriptive material which the accompanying coupon will bring you without cost or obligation.

*Write us for a magazine reprint (with diagrams) giving a technical discussion and complete explanation of "Free Reference Point System of Analysis", and "Technical Data" on Model 85 Tube Tester.

SEE YOUR JOBBER

SUPREME INSTRUMENTS CORP.,
495 Supreme Bldg.,
Greenwood, Miss.

Please send me full particulars on

(Here indicate instrument or instruments interested in)

Name _____

Address _____

City _____

State _____

Jobber Preference _____



Dealers Net Cash
Wholesale Price
\$29.95



Dealers
Net Cash
Wholesale
Price \$39.95

PUBLIC ADDRESS!

From the Microphone to the Horn



TYPE "BF" MICROPHONE

2-button, heavy duty, chromium plated, size: 3 1/4" x 2 1/4". Freq. Resp. 50 to 4,000 cycles.

(One of five available type microphones which includes the velocity type.)

Net Price **\$4.95**

SHORT WIDE ANGLE No. 710 HORN

Constructed of non-resonant material braced with steel. Completely waterproof. Overall length 22", bell 22" x 23".

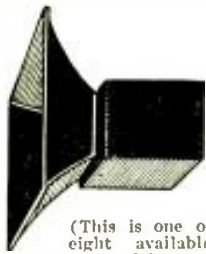

Net Price **\$5.40**

(This is one of eight available types of horns.)

WE ALSO MANUFACTURE:

- 9 Models of Microphone Stands.
- 24 Models of Permanent Power Amplifiers.
- 23 Models of Portable Power Amplifiers.
- 6 Models of Dynamic Field Exciters AND ALL SPECIAL EQUIPMENT FOR THE PUBLIC ADDRESS FIELD.

Microphones and All P.A. Apparatus Repaired.

Send 3c Stamp for Catalogue

RADIO AND AMPLIFIER LABORATORIES

291 East 137th St., New York City

AN AUTOMATIC PROGRAM CENSOR

(Continued from page 729)

talk, and nothing is heard until the music is again begun. By operating another switch, the device automatically works so that it simply changes over to another station when music is discontinued on one, thereby obtaining a constant musical program. Or again an arrangement may be employed whereby the sound-reproducing system is switched to an automatic phonograph or other form of automatic recording device, which will permit the reproduction of a desired record between the musical broadcasts. As soon as musical or vocal selections are again being broadcast the receiver automatically responds again to the radio broadcast. If it is desired to render the speech-eliminating system inoperative, or in other words to have the set perform as a normal radio broadcast receiver, one simply closes a designated switch.

The system of this special receiving arrangement, in detail, is as follows: You may note by Fig. 1, that there is a receiving circuit connected to an input circuit including primary winding 3 of the coupling transformer 4. Secondary winding 5 of coupling transformer 4 is tuned by variable condenser 6. In turn, the tuned circuit connects to the input system of an R.F. amplifier including electron tubes 7, 8 and 9. At this point the detector tube 10 connects to the output circuit of the R.F. amplifier system. The tuning elements 6, 11, 12 and 13 for the R.F. stages and the detector stage of the receiving arrangement are at the same time controlled as shown through dotted line 14. The output circuit of the detector tube 10 connects to the A.F. amplifier system made up by electron tubes 15 and 16 connected in parallel for obtaining greater power output. The output circuit of the A.F. amplifier stages 15-16 includes transformer 17, the primary of which is shown at 18 connected to the output circuit of tubes 15 and 16 through the coupling condenser 17; and the secondary winding of which is indicated at 19 joined to the sound reproducer marked at 20. Coil 21 of the electro-dynamic speaker system composing the loudspeaker 20 is movable and is connected in series with contact 22 of a relay at 23. The field winding of the reproducer 20 is shown at 24 suitably energized from the output circuit of the detector tube 10 as shown at 25. This path leads to auxiliary control tube 27. A selective filter coupling device provides the input circuit of tube 27. A resistor 31 completes the input circuit to the auxiliary tube 27. Grid 27c, of control tube 27, is normally biased to a negative potential of such value that the tube works on or below the lower knee of the characteristic grid-voltage, plate-current curve. Resistor 31 provides this negative potential, and is connected to the ground which is maintained at a negative potential in relation to cathode 27a through the voltage drop caused by a current flow through resistor 48. The circuit of the latter is completed through resistor 50 and conductor 34 to the power supply. Condenser 51 serves as a smoothing unit. Output of control tube 27 leads from the anode 27b to the electro-magnetic helix 32 forming part of a relay. The circuit of 32 is completed with a resistance 33 which goes through at 34 to the power supply circuit. The relay 32 controls the armature tongue 37 which moves with relation to contacts 38 and 39. A vacuum tube relay at 41 has an input circuit passing through the conductor at 42, which connects to tongue 37 of the relay. When the armature moves against contact 39, increased negative potential is placed on the grid 41c of tube 41. This is caused by a negative charge which collects on the grid condenser indicated at 47 through resistance 40 and connection to ground which is normally kept at negative potential with respect to cathode 41a through resistance 48. When the negative charges are placed on the grid, it results in decreasing the plate current in the output circuit. The latter is completed through resistance 33 to the path of positive plate potential through

conductor 34. If the armature tongue 37 is held contacting 39 a given period depending on the resistance and capacitance and the operating constants of the tube used, the negative biasing potential increases until the plate current is decreased to a low value which in turn de-energizes the relay. The relay contacts are thus closed, finishing the circuit through the voice-coil 20 of the dynamic loudspeaker. The device is now ready to receive vocal or instrumental music. When the armature tongue is contacting, the charge will be reduced by leakage through resistance 45 until the potential on the grid will allow enough current to flow in the output circuit to energize relay 23 and to open the circuit to the voice-coil of the loudspeaker making it inactive.

Substitute Programs

When the phonograph is to fill in musical lapses, a system is used, Fig. 2, that switches the A.F. amplifier portion of the broadcast receiver to the control portion of a recorder circuit by which recorded programs are reproduced electrically. To do this an auxiliary unit is coupled to the output circuit of the R.F. amplifier stage and connected to a relay control system. The latter connects the phonograph actuating circuit into the input of the detector tube for using the detector tube as part of the A.F. amplifier system. This includes the R.F. detector stage which is coupled through a conductor and coupling condenser to the output of the R.F. amplifier. The other side of the input circuit to the detector stage is finished by the impedance circuit to the ground. The output of the detector stage is coupled through the coupling circuit with the input circuit of the A.F. corrective tube. A filter circuit is used between the output circuit of the R.F. detector and the input circuit of the subsidiary detector tube. In other words, filter elements at three points are arranged in the circuit with the A.F. rectifier tube to differentiate the range of voice frequencies and the range of musical frequencies to which the detector responds. When the relay is energized due to lengthy speaking or cessation of music, contacts close which in turn cut off the circuit to the driving motor and start the switch of the automatic phonograph.

In cases when it is desired only to eliminate extended speech and not to substitute any other program, this is accomplished by opening the circuit to the loudspeaker. This and the other previously mentioned ways in which the receiver serves is done merely by opening of the various switches. A multi-point switch operated by a single control may be used for these various switching operations.

A system for substituting other radio programs for those in which undesirable speech predominates is shown in Fig. 3.

The speech and music wave-form difference upon which all these systems depend for their operation is immediately apparent to those who can diagnose the graph shown in Fig. 4.

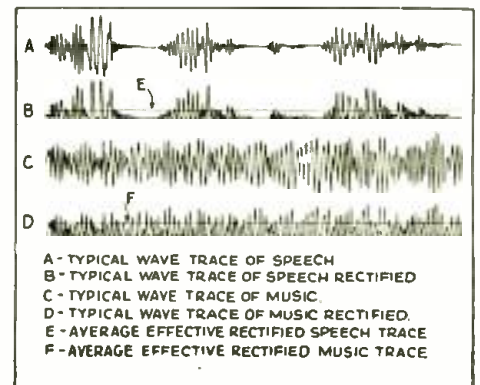

Fig. 4

The differences between speech and music in wave form are clearly shown by the curves above. It will be noted that there are open spots in the speech curves, which permit the censor to function.

ACTUAL TROUBLES IN COMMERCIAL RADIO RECEIVERS

By Bertram M. Freed

If you are a serviceman this book can be as valuable to you as your set analyzer. It points out those faults that the analyzer cannot detect. Over 500 model sets treated. A compilation from thousands of actual records on which the author, with the co-operation of several service organizations throughout the country, spent many months at work.

FREE TRIAL SEND NO MONEY

Examine this book for ten days! If you decide to keep it, send us \$1—if not please return.

Servicemen's Pub. Co., 136-CR Liberty St., N. Y. C.

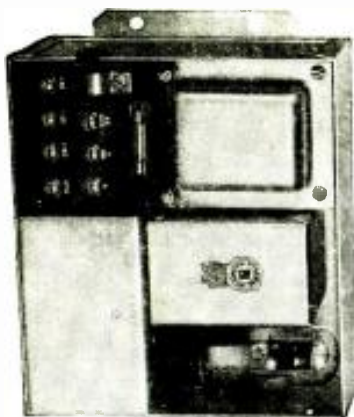

Full-wave tube rectifier Multi-Tap "B" is a source of pulsating AC that is stepped up to high value and converted into DC by efficient full-wave tube rectifier. Steady output — wide range of storage battery voltage.

"Multi-Tap"

(Trade Mark)

"B" POWER SUPPLY UNIT

(Pat. Applied For)

ONE MODEL

(Tube or Tubeless)

REPLACES "B" CELLS ON 90% OF 500,000 AUTO RADIO SETS

Full-wave "Self-Rectifying" Multi-Tap "B" Vibrator fed from 6 v. storage battery creates AC to establish high voltage which is self-rectified into usable DC in the unit.

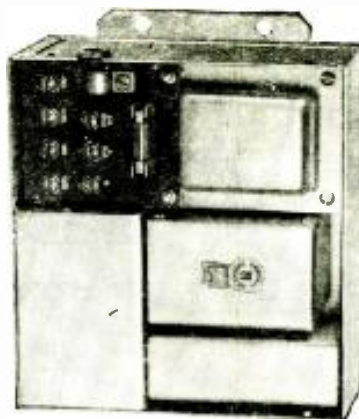

Multi-Tap "B" supplies smooth, quiet, constant "B" power output voltage for auto and motor boat radios. Makes them permanently modern! Gives ninety V., 135 V., 180 V., or 250 V. at various taps on connecting block shown in illustration.

The General full-wave Vibrator has oversized contacts insuring long life. Vibrator assembly self contained and housed in low-resistance, non-magnetic metal case. No liability of mechanical injury or springs coming out of adjustment. Inner vibrator case floated and completely enclosed by sound absorbing sponge rubber container within shielding metal case. Free from annoying hum and R.F. disturbances. Output entirely filtered to eliminate interference and feed-back.

All parts and wiring mounted securely direct on chassis, housed in steel, cadmium-plated cabinet. Many other remarkable features.

General Transformer Corp.
504 South Throop Street
Chicago, Illinois

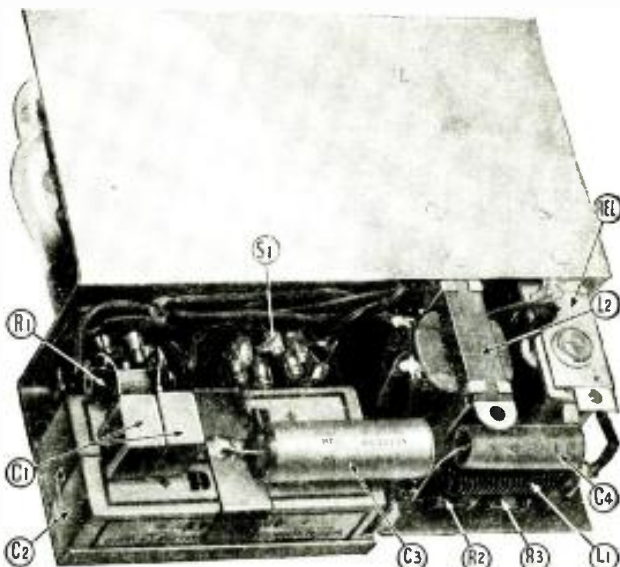

Service Engineers - Distributors
This Field Ripe For Big Profits
MAIL COUPON NOW FOR DETAILS

Easily Installed!
FULL DIRECTIONS WITH EACH UNIT

Full Directions With Each Unit
Each unit packed in individual carton with diagram showing details for connecting in various radios, coded connections with each unit. Multi-Tap "B" for use with 32 V. DC isolated lighting plants may also be had.

Free FOR THE ASKING!

GENERAL TRANSFORMER CORP.
504 South Throop Street,
Chicago, Illinois

Send me, without obligation, Bulletin on Multi-Tap "B" Power Supply Units, and name of nearest distributor.

Name
Address
Town
State

THE RADIOVOTA

(Continued from page 721)

buttons are pressed, as the drum rotates, they make contact with the cam-shape projections on the drum. This immediately inserts a reactor resistor of approximately 100 watts into that circuit of the button which was pressed. As the drum continues to rotate, it reaches a point at approximately 2 A.M. where the cam strikes another spring contact which transmits an increase of power consumption (caused by the reactor resistor, which also will cause a considerable change in the power factor of the line when a large number of these reactors are "pressed" into the circuit) which is registered on a special high-speed recorder wattmeter designed by Dr. Hopkins. This recorder-power factor meter and wattmeter is 96 times faster than the regular type of wattmeter and is therefore more sensitive in its action to register instantaneous changes in power factor.

A sketch showing the approximate arrangement of the device and mechanism employed by the radio "voters" is illustrated in Fig. 1. While the voter may press the button around 8 P.M., the actual recording of his vote will not take place until around 2 A.M. The reason for this can be readily seen by referring to Fig. 2 and noting that power (in kilowatts) consumed at this time of the day is at the lowest point. Thus, any abnormal increase in power factor or power is immediately registered on Dr. Hopkins' specially-designed high-speed recorders.

How Votes Are Recorded

The time delay, from that period of time when the vote is taken to that period when the vote is actually registered, is caused by the slow rotation of the drum driven by a small synchronous motor, geared down to one complete revolution every 12 hours, similar to the hour hand on a clock.

By referring again to Fig. 2, and that portion of the curve indicated by dotted lines, we can get a graphic idea as to how the vote is registered. If, for example, 2,000,000 people press the "Present" button, and each button that is pressed represents an additional power increase of 100 reactive watts, then the total increase in power consumed from the power house will total 200,000 kw.—an increase that the wattmeter will readily indicate. Then the rise in power consumption for those voting "Yes" and "No" is divided by 100 (watts) which will give the total for each and the resulting figures deciding which were in the majority.

In large cities, where more than one power station exists, individual wattmeter installations will be made, and the results from each tallied. Thus the sentiment of various localities or sections may also be ascertained. In this way, radio stations will be able to ascertain what type of entertainment "pulls" best in any part of their consistent audience and the sponsors can be guided accordingly.

Power Consumption Consistent

Some of the descriptions and comments in newspapers of Dr. Hopkins' invention were far from complimentary. This was probably due to lack of understanding of the technical details involved. Most writers were under the impression that it was impossible to gauge at the power house even the normal power consumed at any definite period of time of the day. Their contention was that this factor was so variable and erratic no definite conclusion could be reached, nor any typical curve obtained to illustrate the power consumption supplied by the power house. However, Dr. Hopkins proves, with actual wattmeter curves taken at the power house, that this is far from the truth. The power consumed is practically consistent from one day to the next, with possibly a slight difference where the time element as concerns sunrise and sunset varies from season to season.

A typical curve such as that shown to the writer by Dr. Hopkins is given in Fig. 2. From 12 midnight to approximately 2 or 3 A.M. there is a steady tapering off of power consumption. Between 3 A.M. and 8 A.M. there is a gradual but steady increase in the power that is being consumed, which again decreases rapidly until the 12 noon period is reached. There is a slight fluctuation at that time until 2 P.M., when the power begins to rise again until the high point for the day is reached at about 8 P.M., after which a steady decrease is noted.

Optional Method Invented

Dr. Hopkins has another system, the complete nature of which cannot be divulged, but which will more adequately cover the complete country. This system pertains to a small oscillation generator which is actuated by the voting buttons and which superimposes a carrier current on the telephone system or light supply wires (this will in no way interfere with telephone messages or the light supply, inasmuch as this type of current is known as "radio frequency" and travels only on the outer surface of the telephone lines or power line), and which in turn is recorded on a ballistic-galvanometer. In this system is included a means for compensating or correcting phase displacement which might ordinarily tend to make the vote registration inaccurate.

However, for practical purposes, the first method, either through change of power factor or electrical load, outlined previously seems most suitable. The writer has no doubts, but that Dr. Hopkins has taken every precaution to make his device as practical and tamper-proof as possible. We can be certain that a man of his learning and position is qualified to conceive, and provide for every possibility that might endanger the satisfactory operation of his device. It is understood that basic patent claims have been allowed.

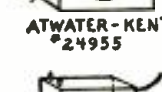
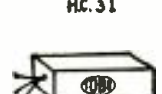
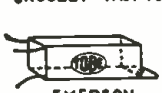
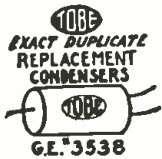

**Exact Duplicate
Electrolytic
Replacement
Condensers**

FOR LATEST MODEL MIDGETS, ALL-WAVE SUPERS, AUTO RADIOS and STANDARD SETS have exactly the same capacity, dimensions, mounting provisions, terminal or lead arrangements, lead lengths, and color codings as originally supplied by the set maker. Voltage ratings have, wherever possible, been increased so as to assure more satisfactory operation and longer service.

The condensers shown at the left are only a few of the exact duplicates now available. Write for Bulletin ED-634 containing a complete listing of replacement units.

**Tobe Deutschmann
Corporation**

Condenser Division

CANTON MASS.

**RELATIVE MERITS OF
AMPLIFIER CIRCUITS**

(Continued from page 728)

The nearer a characteristic curve of a tube approaches a perfectly straight line over its operating range, the closer to perfection it will perform as far as distortion is concerned.

Class A amplifiers operate on this principle. A class A curve is shown in Fig. 1 B-B. Note how closely the center portion of the curve approaches a straight line. To confine the operation of the tube to this straight line portion, it is necessary to bias the grid halfway up on the curve, so that we can vary the grid potential (that is, apply an A.C. signal) either way without approaching the bends at the ends of the curve, which would cause the tube to leave the straight line portion, and according to our first principle, begin to distort.

It can be seen that whether or not A.C. input is applied to the grid, a class A amplifier will always draw plate current. Furthermore, if the grid input is symmetrical, that is, varies as much above the grid bias as below, the average plate current will remain constant and equal to the plate current when no signal is impressed. This means that a class A amplifier draws the same plate power all the time, whether or not it is actually amplifying or regardless how weak or strong the signal input may be. This is the only disadvantage of a class A circuit and it has two subdivisions.

(1) The plate efficiency is low because the maximum plate power is being drawn at all times.

(2) In order to withstand the constant plate current, the tubes must be relatively large, and consequently for higher powers, become expensive.

It must be remembered that any tube can be operated as either a class A, A prime, or class B amplifier, merely by proportioning the grid bias and input signal properly, to have the tube work over the desired portion of its characteristic curve. Naturally, however, some tubes are better suited to a certain class of operation than others. It is well to keep in mind therefore that just because an amplifier utilizes certain tubes is no reason to place it in a particular class unless the operating conditions of the circuit are known. Thus the usual conditions of operation for a pair of 2A3 tubes in pushpull, place them in the class A prime category, since the bias value is set considerably higher than it would be for strictly class A operation. In order to limit this discussion to general characteristics of circuits, however, specific tube types will not be discussed, because everything that is said can be applied to practically all tubes. Also it is well to bear in mind that all characteristic curves illustrated are merely theoretical ones which have been selected to illustrate a point, and thus are not to be confused with actual characteristics of certain definite types. Practical tubes actually have curves exactly similar to the ones shown except that the values of plate current and grid voltage will vary according to type.

Figure 2 shows a typical class B curve for one tube. At first glance this seems identical with the class A curve of Fig. 1. It is very similar but has one very important difference. This tube is operated at such a high grid bias that when no signal is impressed, the plate current is practically zero. Such a condition is arrived at by either operating an ordinary tube at about twice the class A bias, or by using a specially designed tube of such high amplification factor that at zero bias no plate current will flow. In either case a positive voltage impressed on the grid will cause a change in plate current (an increase) but a negative voltage will have little or no effect. (A negative voltage would tend to decrease the plate current, which is already practically zero). Therefore, if we impress an A.C. signal on the grid, only the positive half will be amplified, and the output wave shape will certainly not be an exact replica of the input because the negative half will be entirely lost. To overcome this effect, we introduce another tube so connected that it will be operated by

the other half of the A.C. input. This results in a combination curve as shown in Fig. 3, which is true for two tubes in push-pull. Except for a small region around where the two curves almost meet, this combination curve is practically a straight line. Thus with such a system we should have distortionless amplification except at very low input voltages, which is the region of non-linearity. Here again, our straight line system of analysis is borne out.

Since such a system draws no plate current unless a signal is applied to the grid circuit, it only uses power during the time it is actually amplifying. Furthermore, even during amplification, only one tube is working at a time, while the other tube is resting. Such a condition presents two outstanding advantages.

(1) The plate circuit efficiency is high since power is drawn only during actual amplification and furthermore, the power drawn is roughly proportional to the power output.

(2) Since the average plate current carried by either tube, is both low and intermittent, small tubes can be made to handle very large outputs.

There is really only one theoretical disadvantage to class B circuits. That is the non-linearity of the "zero grid input" region. By choosing properly designed tubes, and by operating them at voltages which will bring the ends of the curves very close together this drawback may be largely eliminated.

That class B circuits can be made to deliver high fidelity output, is proved by the fact that almost every high power broadcast station today, uses a class B modulator. (which is nothing more than a super power audio amplifier). It is true that more than the ordinary amount of care in design is required for proper performance of a class B amplifier. The power supply must have exceptionally good regulation in order to keep the plate voltage constant when the plate current varies. This means heavy duty transformers and chokes. The first condensers must be able to withstand the "no load" voltage of the power supply because, as has been pointed out, unlike a class A amplifier, the class B stage will draw practically no current under certain conditions of operation. The driver stage must be able to deliver sufficient distortionless output to the class B stage if good overall fidelity is to be expected. Design considerations of load impedances and input transformers become very important. It is because of these stringent limits of tolerance that class B amplifiers have not become as popular with amateur amplifier builders as one might expect. Unless he possesses sufficient knowledge of tube circuits and design, the experimenter may have difficulty in getting proper combinations of values. However, amplifier manufacturers have demonstrated that with proper facilities at hand, class B circuits can be made to deliver eminently satisfactory results. Dur-

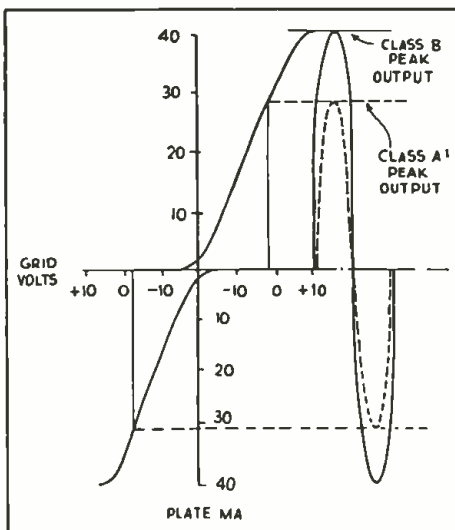

Fig. 4

The combined curves produce a materially straight line.

CLAROSTAT

since 1920, The Profit Line

Replacement Volume and Tone Controls
Standard Volume and Tone Controls
with an Ad-A-Switch consisting of
wire wound (Series "W"), composition
element (Series "C")

Replacement Line Ballasts
Automatic Line Voltage Regulators
Flexible Pig Tail Resistors
Center Tap Resistors
"L" Pads, "T" Pads, Series Mixers

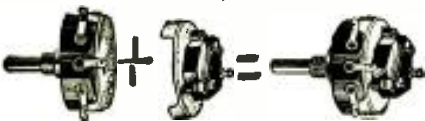

Clarostat Ad-A-Switch Controls



Clarostat
Line
Ballast

Clarostat Ad-A-Switch line
comprises the maximum utility
with minimum stock investment.

Write for New Replacement
Control Guide

Clarostat Mfg. Co., Inc.

287 N. 6th St., Brooklyn, N. Y.



INSIST UPON THIS ENGINEERED EXCELLENCE IN YOUR ALL-WAVE RECEIVER



IN no other all-wave broadcast receiver, mass production or custom built, can you obtain the advanced and latest engineering features you get only in the new and improved custom built MASTERPIECE II—official all-wave receiver of the Byrd Antarctic Expedition II.

Almost any all-wave receiver today will get you foreign stations—if you aren't looking for entertainment and will be content with faint signals, much noise, difficult tuning, and irregularity . . . even under favorable reception conditions.

MASTERPIECE II alone possesses all of the advanced features absolutely necessary, not simply to GET foreign stations, but to bring them in with real entertainment quality, loud and clear, day in and day out, under any and all weather and location conditions. Read over the features of MASTERPIECE II and then compare! No other even all-wave radio gives you more than one or two of them. Only MASTERPIECE II gives you *all* that is necessary for really entertaining reception of foreign stations.

READ! COMPARE!

Tuned r.f. stage on broadcast and all short wave bands increases volume, eliminates noise and repeat spot interference found on other all-wave receivers.

MASTERPIECE II, alone, of all custom built receivers gives you this absolutely essential feature. Band spread tuning dial, on which short wave stations almost impossible to find on all other sets are spread out even more than broadcast band stations. No other custom built set has this feature which often makes the difference between clearly hearing foreigners and entirely missing them.

Three dual air tuned i.f. amplifier stages giving more sensitivity and selectivity than other receivers—and giving it *permanently*, irrespective of climate. No other all-wave receiver gives you this priceless feature.

Automatic volume control that really eliminates fading and holds all stations, weak or strong alike, at the same volume.

Beat oscillator for easy finding of short wave stations and code reception. Here again is the difference between getting and missing foreign short wave stations.

New tone control system that for the first time lets you set tone just as you want it, and that actually suppresses noise with no loss of intelligibility on weak stations. No other radio has this feature.

All latest type tubes, sensitivity better than 1/2 microvolt absolute, selectivity absolute 9 kc., fidelity anything you want, or flat from 30 to 4000 cycles, 17 watts undistorted power output, giant dynamic speaker actually used in latest theatre sound installations, complete polished chromium shielding . . . In fact, everything you can imagine as necessary to absolutely consistent worldwide short wave and unbeatable broadcast band reception you'll find only in MASTERPIECE II.

That's why MASTERPIECE II was Admiral Byrd's choice, and the choice of more competent engineers, physicists, universities and experimenters than have praised any other receiver.

McMurdo Silver, Inc.
1735 Belmont Avenue Chicago, Illinois

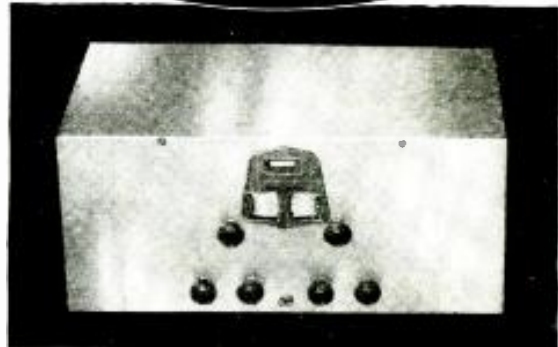
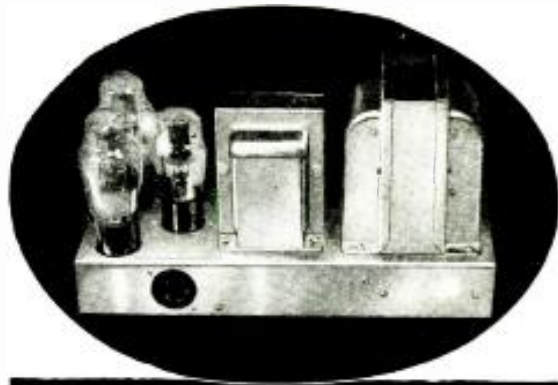

10 DAY TRIAL Send in the coupon for the whole story of the finest all-wave receiver ever conceived by the mind of man . . . a radio so good it can be offered to you on an iron clad guarantee of ten days free trial in your own home . . . your money refunded immediately if you want it. Don't delay, for the best short wave reception season of the year (warm weather) is just beginning.

McMurdo Silver, Inc., 1735 Belmont Ave., Chicago, U. S. A.

Send me full technical information on MASTERPIECE II.

Name

Street

Town

State

ing all this discussion, nothing has been said about grid current. This aspect has purposely been kept for last since it can best be introduced during the treatment of class A prime circuits.

Control-grid Current

In a conventional amplifier, the grids of the power tubes are biased negatively to such an extent that the peak A.C. input voltage will never be greater than the bias voltage. This is done because if the bias were less than the input voltage the grid would become positive, and current would flow in the grid circuit. In the same way the current flows in the plate circuit because the plate is positive. This grid current, although relatively small, causes a large voltage drop across the high impedance secondary of the input transformer, and results in two damaging effects:

- 1) The input transformer is required to deliver power into the secondary, which (if it is a class A input transformer) it is not designed to do. Result: distortion due to transformer overload.
- 2) Since the grid current varies, the voltage drop varies, which causes a "degenerative" effect on the shape of the input wave, causing another type of distortion.

In the class A circuit therefore, the grids are never allowed to become positive.

In class B circuits, however, since the tube operates either at zero, or low bias, with respect to the A.C. input, grid current is present. Its effects are overcome by designing the input transformer as a power transformer, with a low resistance secondary and a core structure which allows it to transfer power efficiently. This insures distortionless input to the power stage, and at the same time takes advantage of the high peak plate current which flows when the grid is positive, thus accounting for the ability to handle great power which class B circuits are noted for.

"A Prime" Advantages

Now a class A prime circuit is merely a compromise between class A and class B. It is a circuit which operates at high grid bias, but never allows the A.C. input to exceed that bias, so that no grid current will flow during operation. It has neither the distortionless characteristic of class A nor the power output and efficiency of class B. It does, however, allow the use of conventional, inexpensive transformers and ordinary power supply with an appreciable increase in output over a straight class A circuit and a minimum of difficulty in design. It is mainly for this reason that class A prime has become popular with amplifier builders.

An indication of the relative merits of types A and A prime can be had from the composite curves shown in Fig. 4. This set of curves shows a theoretical pair of tubes with their performance curves, as class A prime and class B indicating the relative A.C. input swing and power outputs available. The tube can be operated to give output between the limits of the dotted horizontal lines as an A prime stage with ordinary speech transformers and a conventional power supply.

However, by using proper care in transformer design to overcome grid current effects, and by using a power supply of exceptionally good regulation, as well as an output transformer of sufficiently heavy duty type to handle the large plate currents, the input voltage may be increased until the two tubes are operating in the region of grid current, resulting in the greater power output range shown by the larger class B bracket.

Summary of Merits

In conclusion, the characteristics of the three types are as follows:

- 1) Where fidelity is the supreme requisite, class A amplifiers are best, even though they require high voltages and large plate power consumption.
- 2) Where slightly greater power handling capacity is desired in combina-

tion with inexpensive components and economy of power consumption, at the expense of slight decrease in fidelity, class A prime will suffice.

- 3) Where still greater power output is required, a properly designed class B amplifier can be relied upon to deliver highly satisfactory results in many cases so nearly like class A performance that the difference is not distinguishable to the human ear. Increased cost of component parts is warranted by the far greater saving in tube cost and extremely low power consumption.

Any additional information on this subject or information pertaining to the selection of the proper class of equipment for various applications will gladly be furnished by the writer.

RADIO MONTH IN REVIEW

(Continued from page 711)

"Cops" have succeeded in saving many thousands of dollars of property for citizens, as well as apprehending many criminals.

Last month, however, radio tried an even more subtle way of bringing a wrong-doer to justice. Lieut. Beggans of the Jersey City police, heard and enjoyed a skit over station WBXX, Bronx, N. Y. and recognized the voice of James A. Falabella, one of the artists. It seems that Falabella, who worked under an alias, was wanted by the New Jersey police for abandoning his wife and two children during last November.

Wily Lieut. Beggans called up the New York Police Department who picked up the entertainer as he finished his broadcast, and he was hauled into court as a fugitive from justice.

The accomplishments of radio are becoming more varied and numerous every day.



"Ah, my dear Watson . . ."

There's no mystery about the popularity of this new RADIOHM for replacement jobs. You'll detect it at once . . . for it offers smoother, easier, better attenuation than ever before. Try a RADIOHM on that next job.

Note the protecting metal strip that "makes contact" with the resistance strip — noiselessly, smoothly, surely.



Every Radio Service Man should be a member of the Institute of Radio Service Men

Centralab

CENTRAL RADIO LABORATORIES
MILWAUKEE WISCONSIN



SHORTWAVE COILS

Insist on ICA quality when in need of S.W. coils because of their greater efficiency.

ICA BAKELITE RIBBED COILS
Wave lengths 16-217 meters, 4 prongs, No. 1426, List Price . . . \$3.00
Wave lengths 16-200 meters, 6 prongs, 3 windings, No. 1428, List Price . . . \$3.75

Also available in ULTRA-LAW WAVE lengths from 9.21 meters, and broadcast bands, 190-550 meters.

OTHER ICA COILS FOR ECONOMY
No. 1121, 16-217 meters, 4 prongs, Bakelite, List Price . . . \$2.00
No. 1425, 16-200 meters, 6 prongs, Bakelite, List Price . . . \$3.00

ICA INSULEX with HANDLE GRIP
No. 951, 4 prongs, 16-217 meters, List Price . . . \$4.00
No. 965, 6 prongs, 16-217 meters, List Price . . . \$5.00

Your jobber or favorite Mail Order House can supply you with any ICA product at 40% discount. If not write us direct. 16 WIRING DIAGRAMS FREE together with Big New SPECIALIZED S.W. CATALOG. All new and valuable S.W. Data. LIST PRICES on converters, coils, condensers, chokes, etc.

INSULINE CORP. OF AMERICA
23-25 Park Place Dept. C-64 New York, N. Y.



110 VOLT AC POWER From AUTO GENERATORS

This unusual book, complete with drawings and illustrations, tells you how to easily change Ford, Chevrolet, or Dodge generators, and produce 32 to 110 volts, AC or DC. Gives power for radio testing, shop tool operation, floodlights, etc. Price only \$1.

AUTOPOWER, Dept. L, 410 S. Hayne Ave., Chicago

ULTRA-PORTABLE P.A. SYSTEM

(Continued from page 728)

of connection cable is provided with the dynamic speaker, besides 25 ft. of cable for the microphone. Inasmuch as the speaker is mounted within a separable compartment, it is possible to operate the speaker either attached to the amplifier section proper, or removed therefrom and operated any distance apart. There is ample room within the speaker compartment to store not only the microphone and stand, but also all the necessary speaker- and microphone-cable, etc.

On the 2A52 W. model, the input tube is a 53 twin audio amplifier, the first plate of which is resistance coupled to the second control-grid of the same tube, the second plate of which is transformer coupled to the 2A53 tubes in push-pull, operated with a fixed bias. This arrangement provides more than ample gain for use with carbon and crystal microphones, electro-magnetic and crystal phono-pickups, radio tuners, etc.

The same high-gain characteristic is possessed by the 2A5 7½ W. model and by the storage-battery operated 13 W. 79 model.

The class B 79 output tube model will be of considerable interest to those who must employ P. A. systems in automobiles, trucks, boats or wherever 110 V. A.C. power lines are not available. This amplifier system can, at any time, be operated from 110 V. A.C. power lines by merely employing a special power-pack in place of the storage battery—these 110 V. A.C. power-packs are available not only for the amplifier proper, but also for the 6 V. speaker field and 6 V. phonograph motor. A simple plug and cable socket arrangement provides for immediate selection of 6 V. storage battery, or 110 V. A.C. operation.

A valuable feature possessed by this storage battery system is the fact that it consumes 7.2 A. per hour at full load. This is even less than the storage battery drain of a regular car ignition and lighting system. Therefore, the operation of this portable system in an automobile will not impose any undue drain on the car's storage battery. As the total power consumption of the 7½ W. A.C. model is less than 100 W., including the speaker-field excitation and the phonograph motor.

Extreme Compactness

The amplifier chassis itself measures only 13x5x6½ ins. However, no sacrifices were made in either efficiency of operation or in the quality of reproduction. This was made possible by the use of the latest type of high-gain tubes and their associated phase reversing and resistance push-pull coupling. A low voltage-drop mercury-vapor tube rectifier and the use of output tubes requiring low plate voltage assured efficient and simple circuit design with resultant economy in space requirements.

The control board is mounted directly on the phono-pickup and motor board, which has a cutout to assure easy access to the amplifier tubes. The frame of the motor is grounded and the entire motor covered with a shield, to prevent inductive pick-up by either the control board or the amplifier itself, both being necessarily located near the phonograph motor. When the phono-pickup is not in use, it is clamped into a bracket, and of course, clears the loudspeaker mounted in the top cover when the case is closed.

Simplicity of Operation

The extreme compactness of this P. A. system renders its operation extraordinarily simple. It can be set up in a minute! All one has to do is to snap the locks open; insert the line cord into a 110 V. A.C. power outlet; throw the amplifier and the phonograph switches on; and place the phono-pickup on the record, and music or speech, as the case may be, will pour forth from the loudspeaker. The loudspeaker housing may be unbanded from the case and placed or hung in any desired place. Its symmetrical construction prevents it from toppling over if anybody inadvertently comes to rest against it. The loudspeaker front is protected by a metal grille, and prevents any mischievous

or accidental action from damaging it. This is a valuable feature for all outdoor installations, and is only too often neglected.

The microphone in turn, is also provided with a long extension cable, the plug of which is normally inserted into the socket provided for it. No battery of any kind is required, as the power pack supplies the necessary microphone current for the carbon microphone. By manipulating the phono-pickup and the microphone current controls, a background of music may be superimposed upon speech, or one may be faded into the other. A master tone-control permits tone compensation for local conditions and acts also as a feedback eliminator when the loudspeaker is in close proximity to the microphone.

The output of the control board is connected to the first control-grid of a "twin" 79 high-gain amplifier tube. The corresponding plate circuit is resistance coupled to one of the 2A5 pentode tubes, having the unusual high gain amplification factor of 200. An R.F. plate choke and small bypass condenser prevent the pick-up and resultant rectification of R.F. signals. An entirely negligible amount of the voltage output of this first plate is fed through a large coupling condenser and a resistance network to the second control-grid of this 79 tube, the output of which is in turn resistance coupled to the second 2A5 pentode output tube. As the voltages produced by the two plates of the 79 tube are exactly 180 degrees out of phase, true push-pull amplification is obtained, and no bypass condenser need be placed across the 2A5 cathode circuit. The push-pull output transformer has a secondary winding of 15 ohms with taps at 8, 6, 4, 2, 1-1/3 and 1 ohm, thus permitting connection to any number of loudspeakers.

Microphone current supply is obtained from the well-filtered power supply through a resistance network. A resistor remains permanently placed across the microphone supply voltage, as otherwise a high and destructive voltage is placed upon the microphone every time the microphone switch is turned on.

List of Parts for Any One of the Three Models

One portable fibre covered, reinforced and wood-lined portable P. A. case with lock;
One "phono-motor and universal input and output control" board;
One dual speed 33-1/3 and 78 R.P.M. phono-pickup;
One double-button carbon microphone and 25 ft. extension cable with plug;
One combination 4-in-1 microphone ring and stand.

Additional Parts Required for the 7½ W. Output Model

One Coast-to-Coast 7½ W. amplifier and power pack;
One light-weight dual-speed 33-1/3 and 78 R.P.M. phono-motor and turntable, 110 V. A.C.;
One 11½ in. D.C. dynamic matched speaker with 50 ft. extension cable and plug;
One set of 4 tubes, 1—79, 2—2A5, 1—82.

Additional Parts Required for the 12 W. Output Model

One Coast-to-Coast 12 W. push-pull 2A3 amplifier and power pack;
One light-weight dual-speed 33-1/3 and 78 R.P.M. phono-motor and turntable, 110 V. A.C.;
One 11 in. dynamic matched speaker with 25 ft. cable and plug;
One set of 4 tubes, 1—53, 2—2A3, 1—82.

Additional Parts Required for the 13 W. Output Model

One Coast-to-Coast 13 W. class B, 3 stage amplifier and 6 V. motor-generator unit;
One light-weight dual-speed 33-1/3 and 78 R.P.M. phono-motor and turntable, 6 V. D.C.;
One 11 in. 6 V. D.C. dynamic matched speaker with 25 ft. extension cable and plug.
One set of 4 tubes, 1—89, 3—79.

SUPER BATTERY PORTABLE

(Continued from page 727)

latter should be so connected (series-parallel) that the terminal voltage is 3 V. This combination will give uniform life of the "A" and "B" batteries. Should the builder desire a longer battery life, with a slight loss of sensitivity, use two No. 9303 "B" batteries. This will greatly lengthen the "B" battery life as it cuts the drain from about 13 to 8 ma. When changing the operating voltages remember to use one-half the maximum plate voltage on the screens.

Contrary to the belief of many engineers this circuit is not critical as to tube characteristics or to voltages applied to plate, screen-grid or filament (filament voltage should not exceed 2.15 V., of course).

The sensitivity curve (Fig. 4) will give some idea of what this little set will do, and why it can operate so well on a small loop.

The loop is wound around the portable carrying case: 16 turns of litz. wire spaced $\frac{1}{2}$ -in. will be all that is necessary. This wire should be wound in a groove in the case before the covering is put on. It is a good idea to paint the loop with several coats of lacquer before covering.

This portable may be used as a home radio, equal to any home set on the market, with the addition of a permanent magnet dynamic speaker in a cabinet large enough to form a good baffle. A short aerial of about 50 ft. and a good ground, should be used to eliminate the directional effects of the loop. With the use of large sized "B" batteries, and large multiple "A" battery units, the cost of operation will be about equal to a large A.C. set.

Constructional Data

The little portable set described is complete in a wooden cabinet 14 x 12 $\frac{3}{4}$ x 8 ins. deep. The outside is covered with imitation leather. The chassis is mounted on a shelf above the batteries and is 12 $\frac{3}{4}$ x 7 x 2 ins. deep, made of No. 20 black iron, chromium plated. The entire equipment, including batteries, weighs 28 lbs.

The layout arrangement of the chassis is very important. (See sketch 1, Fig. 3.) Dimensions may be altered but the general arrangement should be adhered to.

This set is not hard to build if no alterations or substitutions are made, but slight changes will bring disastrous results. You must bear in mind that here you are crowding together in one small unit an enormous amplifying system, and any type of capacity or inductive coupling is apt to throw the system into oscillation. Shielding must be very thorough. Incorrect grounding, omission of filament chokes, or bypass condensers will cause coupling between the detector and I.F. tubes. This will manifest itself in whistles and howls. The second and third harmonics of the intermediate frequency are most liable to cause trouble.

The design of this set was very carefully worked out. Over 16 different models were built and studied and the one to be described is the result of this work. It is beyond the scope of this article to describe in detail why this or that is done, or how the final results were obtained, but if any readers are interested, they may write RADIO-CRAFT for further information.

Assuming that the reader is going to follow this design in detail, we will begin with the antenna circuit (see Fig. 2). Three binding posts are used, one for an antenna, in case one is ever desired, one for the loop and one (grounded to chassis) for loop or ground as desired.

The antenna coil primary is honeycomb wound with 100 turns of 11-strand No. 40 litz. wire. The secondary, or grid coil, consists of 144 turns of the same wire wound in the same manner. The coils should be spaced so that adjacent sides are $\frac{1}{2}$ -in. apart (see Fig. 1). Connect as shown.

The first I.F. is a little out of the ordinary in that the primary is a small honeycomb coil of 95 turns of No. 38 D.S.C. wire tuned with a .001-mf. condenser across which a trimmer of 100 mmf. maximum capacity is connected. The primary is located at the

top. The secondary has 375 turns of the same wire and wound in the same manner. It is located below the primary so that the adjacent sides of the coils are $1\frac{1}{4}$ in. apart (see Fig. 1). Connect as shown. The secondary is tuned with a trimmer condenser with a maximum capacity of 100 mmf. Due to the wide variation in commercial .001-mf. condensers, and the small trimmer condensers, the number of primary turns may have to be varied slightly.

The second and third I.F. transformers are exactly alike. Each has two coils, honeycomb wound, consisting of 375 turns of No. 38 D.S.C. wire. The primary is at the top, and the secondary is located below so that the adjacent sides of the coils are $\frac{3}{4}$ -in. apart.

The oscillator coil is wound on a piece of bakelite tubing 1 in., outside dia., 2 $\frac{1}{2}$ ins. long. Start the winding at one end (let us call it the top). Wind down 58 turns of No. 38 D.S.C. wire. This is the winding that is tuned (see drawing). The start of this winding goes to the primary of the first intermediate, and the end goes to "B plus" 1.5 volts. At a point $\frac{1}{8}$ -in. down, start winding the pickup coil, 38 turns of No. 28 D.S.C. wire, wound in the same direction as the first coil. The start of this winding goes to the filament of the combined detector-oscillator tube and the finish goes to the chassis ground.

Many details, such as padding, etc., are shown in the circuit diagram, Fig. 2. The detector and audio circuit are of the conventional type but be sure to adhere to the values given in the diagram. Otherwise the tone, sensitivity or battery drain will suffer.

The two filament chokes, No. 11, are 100 turns of 11-strand No. 40 litz. wire, honeycomb wound. These coils must be so located that the leads are very short. In other words, they must be mounted very near the tube sockets to which they are connected. A D.P.S.T. switch is used for opening the "A plus" and "B minus" circuits.

The writer will be very glad to hear the readers' comments and reactions to the ideas set forth in this article.

List of Parts

- One triple binding post unit, 1;
- One Hammarlund equalizing condenser, 100 mmf., 2;
- Three Aerovox 50 mmf. fixed condensers, 3;
- One special loop, 4;
- Four resistors, .15-meg., $\frac{1}{4}$ W., 5;
- Six .1-mf. (Polymet) tubular condensers, 200 V., 6;
- Six .5-mf. (Polymet) tubular condensers, 200 V., 7;
- One set of antenna and R.F. coils, 8;
- One 3 gang variable condenser with special oscillator section, 9;
- Two 12,000 ohm resistors, $\frac{1}{4}$ W., 10;
- Two special filament chokes, 11;
- One special oscillator coil, 12;
- One Aerovox .0025-mf. condenser, 13;
- One Insuline condenser, 75-350 mmf., 14;
- One first I.F. transformer, special, 15;
- Six Insuline condensers, 5-100 mmf., 16;
- Three Aerovox .001-mf. condensers, 17;
- Two 1 meg. resistors, 18, 25;
- One 50,000 ohm, $\frac{1}{4}$ W. resistor, 19;
- One 2 meg. resistor, 20;
- One 50 mf. 25 V. (Polymet) electrolytic condenser, 21;
- One 4 mf. 200 V. (Polymet) electrolytic condenser, 22;
- One .5-meg. 1 W. resistor, 23;
- One 75,000 ohm, 1 W. resistor, 24;
- One .05 mf. (Polymet) 400 V. tubular condenser, 26;
- One 300 ohm 1 W. resistor, 27;
- One 1000 ohm wire-wound potentiometer, 28;
- One double-pole single-throw toggle switch, 29;
- Two I.F. transformers, 2nd and 3rd, 30;
- One twin binding post unit, 31;
- One type 112, 32;
- Five 4 prong sockets, 33;
- One 5 prong socket, 34;
- One magnetic speaker—5 in. size, 35;
- One cabinet, 36;
- One metal chassis, chromium plated, 37;
- Three No. 5303 "B" batteries, 38;
- Four No. 6 dry cells, 39;
- Five National Union type 32 or 951 tubes;
- One National Union type 950 tube.

SHORT-CUT SOLUTIONS

TO SOME EVERYDAY PROBLEMS



More than 250 handy methods discovered by practical service men!

In Sylvania's FREE service booklet "Service Hints," hundreds of successful service men give you the low-down on tough problems they have solved. Their tips may save you hours of trouble-shooting on some perplexing job.

Mail the coupon for this useful book today. We'll send it without charge, and put your name on the mailing list for Sylvania's free monthly service bulletins, too! You get handy information on all leading modern sets . . . and additional help each month.

And if you have any pet methods of your own, the Sylvania Bulletin will tell you how to get free tubes by telling us your own discoveries.

HYGRADE SYLVANIA CORP.

Makers of
SYLVANIA TUBES HYGRADE LAMPS
ELECTRONIC DEVICES

Factories
EMPORIUM, PA. ST. MARYS, PA.
SALEM, MASS. CLIFTON, N. J.

© H. S. Corp., 1934



HYGRADE SYLVANIA CORPORATION B-11
Emporium, Pa.

Please send me your free booklet "Service Hints" and your free monthly Service Bulletin.

NAME

ADDRESS

CITY STATE

HOW TO BUILD, TEST AND REPAIR RADIO SETS



Radio Construction Library

Including Television, Short-Wave Receivers and Auto Radios. 3 Volumes, 6x9—1177 pages, 561 illustrations. This practical Library includes: PRACTICAL RADIO—The fundamental principles of radio, presented in an understandable manner. Illustrated with working diagrams. PRACTICAL RADIO CONSTRUCTION AND REPAIR—Methods of locating trouble and reception faults and making workmanlike repairs. Discusses modern Short-Wave Receivers and installation of automobile radios fully. RADIO RECEIVING TUBES—Principles underlying the operation of all vacuum tubes and their use in reception, remote control and precision measurements. Helps you to understand modern type receiving sets—full of construction data and practical kinks for the experimenter—a training course for service men.

10 Days' Free Examination
Easy Terms

McGraw-Hill

FREE EXAMINATION COUPON

McGraw-Hill Book Company, Inc.,
330 W. 42nd St., New York.

Gentlemen:—Send me the new RADIO CONSTRUCTION LIBRARY, all charges prepaid, for 10 days' Free Examination. If satisfactory I will send \$1.50 in 10 days, and \$2.00 a month until \$7.50 has been paid. If not wanted I will return the books.

Name

Home Address

City and State

Position

Name of Company.....RC-6-34

A RADICALLY NEW TUBE TESTER

NOTE FEATURES AND UNEQUALLED PRICE OF THE 22

1. Neon leakage and complete short test automatic.
2. Line voltage regulation, —Plate and filament.
3. English reading scale.
4. Tests all tubes. Provisions for future types. New tubes can be added without removing instrument from case.
5. AND allows capacity tests good—bad—leakage (vacuum tube voltmeter principle)
6. Resistance measurements 500 to 2 megs wide separation.
7. Continuity tester on neon or meter.
8. Veri-chrome lettered bakelite panel.



\$22.50

This tube tester and shop tester for a price of only \$22.50.

10 days trial—money refunded if not satisfactory.

L & L ELECTRIC COMPANY

Dept. 9-A
336 MADISON AVE. MEMPHIS, TENN.

PRACTICAL RADIO ENGINEERING

An opportunity for RADIO MEN to enlarge their scope of training.

Whether elementary radio principles or advanced subjects, sound applications or practical radio engineering, RCA Institutes is prepared to give you the instruction you need.



RESIDENT SCHOOLS NEW YORK AND CHICAGO with modern standard equipment

EXTENSION COURSES FOR HOME STUDY under convenient "no obligation" plan.

Illustrated Catalog on Request

RCA INSTITUTES, INC.

Dept. RT-6
75 Varick Street, New York
1154 Merchandise Mart, Chicago

UPLIFTING THE SERVICE PROFESSION

(Continued from page 725)

posing the 12 million radio sets represent the product of 200 radio set manufacturers; old-timers in the field. To the writer these 200 manufacturers mean men who have given the best of their engineering skill and years of their time to design the sets now in the customers' homes. The success, not only of these men and their companies, but of future radio business as a whole, will depend solely upon the satisfaction of the users and the life of the set. It must be remembered that the manufacturer of these customers' sets depends upon repeat orders from the customers when they desire newer sets to replace their old ones when they are worn out.

Rules for Service Men

Allow the writer to state that during the past 15 years of contact with the radio public and following the footsteps of many Service Men, there has been on the part of the Service Man entirely too much knocking of the radio sets they have been called in to repair.

On one occasion I was asked to service a battery set. After making an inspection of the set and noting that someone had already torn the set apart, I told my customer that I did not believe the set would justify the expense of rebuilding; that the best thing to do was to trade it in on a new set. My customer asked me to wait while he called in a dealer. This dealer sent his Service Man down to appraise the set and here is what happened.

This Service Man no sooner came into the room and noticed the set when he just puffed up and said, "Well, well, I don't blame you for wanting to trade this set off. Why, that manufacturer never did build a set that would work—they are too cheap." And did he burn it up!

The customer said, "What will you give me for it on a new set?"

The Service Man replied, "Well, I can't allow you more than two dollars for it."

The customer of course blew up and said, "Nothing doing—I paid \$125.00 for that set only two years ago."

When the Service Man saw that he was losing out he back-tracked, finally telling the customer he could re-design and rebuild the set so that it would give him much better service!

The customer came into the next room where I was, told me what the Service Man said, stating that since he was ready to buy a new set anyway, he would let the Service

Man build it over and then peddle it off, as he couldn't get anything for it the way it was. The Service Man agreed to rebuild the set, let the customer try it out and if it was any better he could pay him for his work. But the "re-designed" set never did work right, and this Service Man never did get his money.

The point is just this: NEVER ATTEMPT TO GO THE MANUFACTURER ONE BETTER. REPAIR THE SET JUST AS THE MANUFACTURER DESIGNED IT. If it doesn't work like other sets of different manufacturers, let the customer find it out, as this is the only way reliable merchandise can be recognized. I always figure that the manufacturer has sufficient laboratory service and engineering skill to know more about it than I do—or else I would be a radio set designer. (Editorial note: The aforementioned fact is something a great many Service Men should remember.)

The moral of the above story is: Service Men—know your limitations and never try to exceed them!

Of course, I have spoken from the free lance Service Man's side—the man who does not sell radio sets but sells only service and accessories. The angle is a little different with the dealer who sells radio sets and service, but tactful salesmanship will handle this problem successfully.

Free Lance Servicing Versus Dealer

In towns of 10,000 population and less, the average dealer cannot afford to equip and operate a shop on a scale as that of an independent Service Man. The fact that the dealer is looking for the profit on the merchandise sold will always encourage the dealer's Service Man to be more intent upon selling, rather than to see that the radio sets stay sold. I have seen many such Service Men sell a new set of tubes, instead of replacing a new resistor as should have been done—and the customer's set soon acting as it did before serviced. The dealer's Service Man will always sell a new set when he has a chance for profit to himself! Now maybe the customer has just facts and reasons for not wanting a new set. If he crowds the sales argument, the customer feels that the Service Man is just trying to sell him. This alone has come to my attention so many times that I guess I can't see anything but an independent service shop.

So many customers have repeatedly said: "I feel free to talk to you about my radio set. I know you will not try to sell me a new set but if you really say my receiver is worn out, I'll take your advice and get a new one." Is this not proof enough that fair dealings and honesty will make a service shop pay? It does, and pays well, if good, common sense business methods are followed.

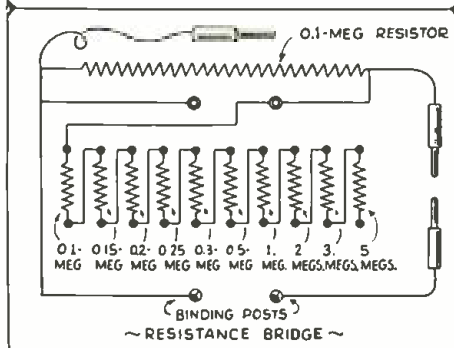
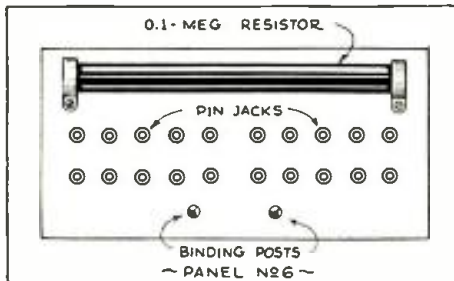

A condenser bank for substitution work in set testing. The instruments shown here are part of the Service Man's "kit of cures."

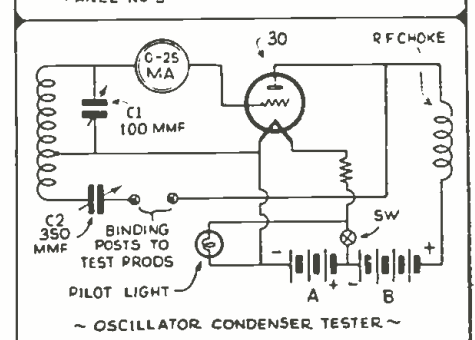
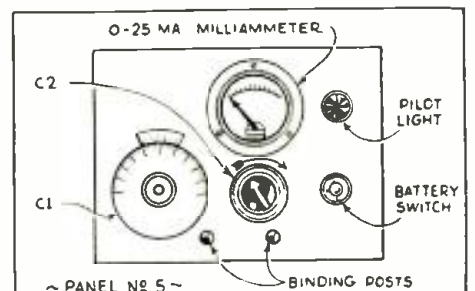

A combined oscillator and condenser checker—the panel appears above.

the new tubes in it?" To me this point is like trying to take an Ingersoll watch and put the parts of a Hamilton in it. It just can't be done and done right or profitably.

I figure that the radio has been designed and built and balanced for that particular set-up like the Ingersoll watch. Although there are certain times when a new tube can be used in a certain socket, I am taking the point of the whole set of tubes to be changed for the new ones. If this was possible we would not have made advancement in the art that has been made up to date.

When you are called in to service a radio set give the best service of which you are capable, and remember that you have a wonderful field to sell supplementary merchandise, such as additional loudspeakers, remote controls, new aerials and plugs, etc. Public address amplifiers can be used, in the home, for nurseries and maid service. The idea of re-mounting radio chassis in cabinets or other pieces of furniture, as well as in the walls of a room and many other places, can be sold. Truly, there is a wide field for the independent service shop if the technician will just use his head and apply a little ingenuity. And how about the auto radio field which goes hand in hand with service shops?

Learning Radio Fundamentals

Let us stop for a moment and make a quick analysis of the radio set, and what constitutes its general make-up:

- (1) There is the steel chassis;
- (2) The wire used for connections;
- (3) Condensers—fixed, variable and electrolytic;
- (4) Resistors—fixed and variable;
- (5) Radio tubes;
- (6) Tuning coils and transformers.

Now the first two items do not cause us much concern, but the rest are our chief "bread and butter" elements. In building up a radio service shop let's hold to these last four items as the basis upon which our knowledge and technique is to be built, and design our equipment around those fundamentals. It is assumed that the prospective shop builder has had a thorough grounding or schooling in radio, and knows the science of these four basic elements so well that when a set comes in to be repaired he can take one look at it, determine whether it's a "super," or "T.R.F." set and draw a mental picture of the fundamental hook-up, and thus picture how the various circuits perform or work.

When parents of radio minded boys ask what is the best education a boy can take to become a radio technician I wonder if they really realize that radio science has now progressed to such an extent that it means many years of radio school and practical set study. I tell them the first thing advisable to do to become a radio technician is to learn the radio telegraph code. If the prospect can

master this to the speed of 20 words per minute, he certainly has enough intestinal fortitude to take a complete radio course from some of our well-known schools—he certainly will stick to radio in any of its branches, and most likely make a success of it. I don't know of anything that will test a person's patience and bring out his stick-to-it-iveness more, than the mastering of the radio telegraphic code.

Service Receivers in the Home?

As the writer has spent the last 20 years in radio selling and servicing—in fact, grew up with radio—the much debated question that the Service Man has to contend with is, "Should radio sets be serviced in the customer's home?" My experience and ideas to date are, absolutely, "NO!"

Let's look into this from the customer's side. Consider the mistress of your customer's home. Would you like to have the "insides" of your radio set spread all over the floor—the soldering iron heating up on your table—the dust and dirt that is bound to collect on and in the radio chassis scattered all over your clean floor or rug? Of course you wouldn't. Mr. Service Man, did you ever find a customer's table that would make the right kind of bench; or one that didn't have to be careful of scratching? No, of course not! Did you ever find plenty of light on your work from the average living room, chandelier or reading lamp? Did you ever have with you just the tools you would like to use; or just the parts you needed on the first call? I'll bet the last 20 radio sets you serviced you cannot truthfully say, "It was just as easy to do the work in the customer's home as in my shop." Would your doctor come to your home and perform an operation on your tonsils; or operate on you for appendicitis on your dining room table or youravenport? I'll say he wouldn't. Then why is it any more logical for a radio Service Man to operate on your radio set in your parlor than it is in a place where you have taken the greatest of pains to build your shop so you can render efficient service in the shortest possible time?

I can't see why most Service Men don't pick up old second-hand radio receivers, recondition them in their spare time and lend these sets to their customers while repairing their sets. No customer will object to using your set while his is in the shop. In some instances you might sell this set to the customer, because his family's program desires interfere with his selection of programs. Also there may be a housemaid for whom the owner would get an extra set to help keep her contented with her job. In addition, the lending of this set allows you more time to do a better job on his set, permits you to arrange your work so as to handle more calls (this idea alone will more than repay you), and may enable you to sell a set.

How many times have you been called in to fix a set—say about three or four o'clock in the afternoon—only to make a set analysis and find that a condenser section is out; you still have about four other calls to make, yet your customer states that he "has friends coming in for evening to play bridge and there is a certain program that they want to hear?" Who hasn't labored many times under this condition? Wouldn't the convenience of a set that you could lend him let you out nicely and allow you to do a real job on his set? You bet it would!

Radio Servicing is a Profession

So let's take off our coats and study this service problem in real earnestness. First of all, what is radio servicing? To the writer it is a profession—a profession on the same basis as that of a doctor. The real Service Man has spent years in study, and has taken some kind of schooling to fit him in this science. This is not just "plier and screw-driver" work; and it's not a trade that can be learned by simply doing work on radio sets. It takes *study*. It takes *experience*. It takes *brain work* and *ingenuity*. If Service Men will just look back over their experience they can see that it has taken a lot of money, to get their experience, as well as time and study.

If you, Mr. Service Man, have learned that the secret of success is hard work, then give

Put No. 710 ON YOUR PAYROLL



HERE'S a quicker-acting, easier-operating tester that enables you to make more calls at the lowest possible cost! Here's a tester that thousands of service men prefer because it makes each day's work net them a bigger income. Put No. 710 on your payroll—NOW!

The No. 710 Tester tests all types of radios . . . both new and old—and easily handles the most advanced circuits and newest tubes. This better tester is equipped with a practical selector switch which makes it easy to check all parts of tube circuits by connecting to the set sockets. Selection for testing voltage of plate, grid, cathode, suppressor grid and screen grid is quickly and accurately done. Plate current, filament volts, line and power supply volts, resistance and continuity are measured also. A battery is furnished for continuity testing of transformers, chokes, etc.

The No. 711 Tester is the same as the No. 710 . . . except that it is equipped with the new Triplett D'Arsonval Volt-Ohmmeter. This instrument has 1000 ohms per volt resistance. Its easy-reading scale makes it possible to accurately read up to 3,000,000 ohms.

Your Jobber Can Supply You . . . with these advanced testers at Dealer's low net prices. The No. 710 Tester is only \$16.50. The No. 711 Tester is only \$24.75

Readrite Meter Works 
110 College Ave. Bluffton, Ohio

Literature is FREE! Write today.

READRITE METER WORKS,
110 College Ave., Bluffton, Ohio

Gentlemen: Send me catalog on Readrite Testers No. 710 and No. 711 . . . and complete line of servicing equipment. Also send "Proof" folder, which illustrates letters from service men.

Name

Street Address

City State

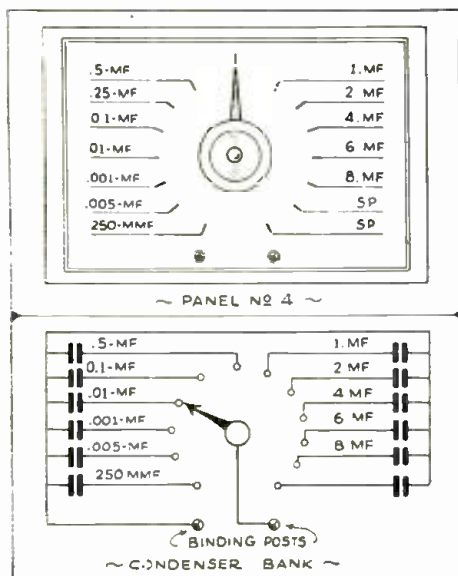

A useful resistance bank for resistance measurement.

BUILD YOUR OWN SHALLCROSS UNIVERSAL TESTER

For \$41.50 Complete



**VOLTS
A.C.-D.C.**
5-25-100-250-1000
1000 ohms
per volt

**MILLI-
AMPERES
D.C.**
1-10-100-1000

CAPACITY
.001 - 10 Mfd.
Paper or
electrolytic
condensers

**INDUCT-
ANCE**
1 - 10,000 Henrys

5-5,000,000 ohms D.C. Resistance

Send 6¢ in stamps for the new Bulletin No. 611-P containing the complete wiring diagram and operating instructions for this modern serviceman's instrument.

SHALLCROSS MFG. COMPANY

Electrical Measuring Instruments
and Accurate Resistors

700 MAC DADE BOULEVARD
COLLINGDALE, PA.

WORLD WIDE ALL WAVE RADIO



A real, powerful long and SHORT WAVE Radio Receiver that actually gets local and foreign broadcasts, police, amateur, airplane, etc. Transmissions direct! So simple and fool-proof that no radio knowledge is needed to put it into operation! Thousands now in use. Owners report reception of Foreign Stations with amazing volume. Work on two inexpensive batteries. Not a toy! RESULTS GUARANTEED!

See construction kits have all necessary parts mounted on attractive metal chassis and panel, all ready for wiring. Clear picture diagrams. Wire it yourself! It's easy. Only six connections and the set is ready to operate. Wavelength range 15 to 600 meters. Complete Kit, with coil.

ONE TUBE KIT \$1.95 • **TWO TUBE \$2.85**
(Wired and tested for \$1 extra)

TUBE—Special type for use on one dry cell.....\$.85
PHONES—Double Headset.....\$1.25
ORDER NOW! Send \$1. balance C.O.D., or if full remittance we pay postage.

LOOK! NOW!

ACE RADIO LABORATORIES

1619 BROADWAY Dept. R6 NEW YORK, N. Y.

**WET AND DRY ELECTROLYTIC
PAPER AND MICA CONDENSERS**

RECOGNIZED FOR
SUPERIOR QUALITY
IN ALL CLIMATES
THE WORLD OVER

SOLD BY LEADING
JOBBER EVERYWHERE

SOLAR MFG. CORP.
599 BROADWAY
NEW YORK

BEST BY TEST!

ASK FOR
CATALOG
OF EXTREMELY
COMPACT TYPES
HANDY FOR SERVICE

just a little bit more for the price of the job it, good hard effort to please. Take time enough to clean and polish the cabinet, see that the dial is in the center of the opening, the knobs are tight and free. Tell your customer that he has a nice set and that it has been well taken care of, and then you will never have to worry about competition or your price. Be sure to explain that you guarantee your work and for them to let you know at once if there is anything that is not satisfactory. Do these things and you can expect success in radio service work.

The following are closely approximate figures for equipping a radio shop. The procedure for going into this business and conducting it properly will be outlined in the next issue.

Approximate Cost for a Radio Service Shop

Test Equipment (Oscillator and Universal Meter)	\$150.00
Radio Bench	40.00
Radio Bench Test Panels	100.00
Radio P.A. Rack (complete)	85.00
Work Bench	15.00
Counters (2)	20.00
Machinery (drill press, saw table, grinder, motor and shafting)	120.00
Machine Bench	12.00
Tube Checker	50.00
Air Compressor	25.00
Hand Tools	150.00
Show-case (second-hand)	20.00
Desk (second-hand)	30.00
Lighting fixtures	30.00
Stationery	35.00
Table and Chairs (second-hand)	15.00
Painting and remodeling store and shelving	100.00
Signs	75.00
Wiring of store	50.00
Tube stock	100.00
Radio stock of parts and accessories	400.00
Car (second-hand)	250.00
Office supplies (filing cases, typewriter and books, all second-hand)	100.00

\$1,972.00

(to be continued.)

INFORMATION BUREAU

(Continued from page 736)

AUTO-RADIO NOISE SUPPRESSION

(263) William Brown, New York, N. Y.
(Q.) I have been reading with interest the various articles in RADIO-CRAFT regarding auto-radio noise elimination. I have done a good deal of installation work, and there are some installations which just refuse to respond to any of the treatments (although I have not tried the shielding method described in the April issue).

I am particularly interested now in a method that I read about, but cannot find any practical information as to how to make the device or how to connect it to the ignition system of the car. I am referring to the method of tuning the ignition system to a frequency remote from the broadcast band. Can you tell me how this method is worked and how I can make an experimental set-up to try it out?

(A.) We are showing a section of a common car ignition system, in Fig. Q.263. This includes the ignition coil and the breaker points of the distributor. The ignition transformer (or coil as it is commonly called) in conjunction with the distributor and the spark plugs constitute a circuit almost identical in action with the spark transmitters used years ago. The circuit constants of many cars unfortunately tune this spark transmitter circuit to a frequency within the broadcast band or to a harmonic of some of the broadcast band frequencies. It is well known how broad a spark transmitter tunes. From this explanation, it is easy to see why interference is set up in the sensitive auto set. There are commercially available units for the purpose of tuning this spark transmitter circuit to a frequency far removed from the broadcast band, so that any harmonics that fall in this band are so weak that they do not cause any trouble. In the circuit, Q.263, we have shown the

FREE! Choice of One or More of These Popular Short Wave Books

Here's money put right into your pocket—here's a saving you never have a thought to. You get absolutely FREE any one or more of the regular 25c and 50c short wave books with a year's subscription to SHORT WAVE CRAFT, the Radio Experimenter's Magazine. A one year's subscription brings you one fifty cent book or two twenty-five cent books; a two-year subscription brings you two fifty cent books and any one twenty-five cent book. Decide NOW what books are most necessary to you—then send us your subscription by return mail. The books will be sent to you immediately.



No. 1 50c No. 2 50c No. 3 25c No. 4 25c

THIS popular short-wave magazine interests the great army of "hams," broadcast listeners, and general radio students who are interested in experimental as well as scientific angles of short wave development and application. In each monthly issue appears the largest and most correct short-wave station call list, and important construction articles on receivers and transmitters, including "disturber" diagrams easily understood by anyone, a big feature "originated" by SHORT WAVE CRAFT. You'll also find the latest news about short-wave physics, micro- and ultra-short waves and other applications of this newest branch of radio.

Many Short Wave Sets to Build

Many excellent short-wave sets with complete construction details with "picture" diagrams, are found in every issue—these sets vary from simple one- and two-tube sets to those of more advanced design, five and eight tubes.

Big Silver Trophy FREE!

Recently inaugurated by Mr. Hugo Gernsback, Editor, was the "Short Wave Scout Contest." To the Short-Wave "fan" who has logged and obtained verification of the largest number of short-wave stations from all over the world, during one month, will be awarded a magnificent silver Short Wave Scout Trophy.

25¢ The Copy

4-Color Cover 9" x 12"—
Over 200 Illustrations



On All
Newsstands

SHORT WAVE CRAFT, Dept. RC-634
96-98 Park Place, New York, N. Y.

Gentlemen: Enclosed you will find my remittance for a subscription to SHORT WAVE CRAFT for
[] One Year @ \$2.50 (Canadian and foreign \$3.00)
[] Two Years @ \$5.00 (Canadian and foreign \$6.00)
Send me FREE books which are circled below.

1 2 3 4

Name

Address

CityState

(Send remittance in check or money order. Register letter if it contains cash or unused U. S. Postage Stamps.)

MAIL COUPON TODAY

addition of a coil and two condensers which are connected to the binding post on the side of the distributor. This post is the 6 V. battery connection to the breaker point. This tuned circuit is a shunt tuned circuit similar to the tuning circuits in a radio set. It will be noticed that the ground is made to the mid-point between the two condensers. This prevents a short circuit of the distributor.

The coil for this noise filter is wound with 440 turns of number 32 enamel wire on a form 1 in. in diameter. The turns are random-wound in a space 1 inch long on the form. The condensers are .01-mf. mica or paper insulated units, preferably the former. The coil and condensers should be placed in a metal box, at least 4 ins. to a side, and mounted as near the distributor as possible.

Additional, and more detailed information on the design and installation of a noise "tuner out" (by resonating the ignition circuit of the car) is contained in the article, "Reducing Car-Radio Interference," by Frank N. Mayer, which appeared in the June, 1933, issue of RADIO-CRAFT, pg. 745. (This item was a further comment in connection with the article, "Interference Elimination in Car-Radio Installations," in the February, 1933, issue, pg. 479.)

NATIONAL FB-7

(264) Mr. J. B. Harrison, Knoxville, Tenn.

(Q.) Can you print the circuit of the National FB-7 receiver and explain what the two oscillators are for. I have seen this circuit printed recently, and I am puzzled by the two oscillator circuits. Is this a double-super in which the signals are heterodyned twice to match the intermediate frequency?

(A.) The circuit of the National FB-7 set is shown below, Fig. Q264. The oscillator at the left side of the circuit is the usual superhet. oscillator for frequency changing. The other oscillator is a beat oscillator for making a carrier wave audible. This oscillator is tuned to a frequency 1000 cycles away from the intermediate frequency. By beating with any incoming carrier, a whistle is heard. This simplifies tuning 'phone stations, and is essential for CW code signals, as otherwise, only the key clicks would be audible. This condition is commonly known to all amateurs who use superheterodyne sets for picking up code signals. This oscillator is equipped with a switch so that when a phone station is tuned in, the whistle can be eliminated.

It is interesting to note one other point about this receiver. The first-detector and oscillator tuned circuits are arranged in such a way that ordinarily the condenser shunts only a part of the coil. This is for the purpose of "bandspreading," to simplify the tuning. However, the coils are provided with bases having enough prongs so that all terminals come out; hence it is possible to plug in coils having the tuning condenser connected across the entire winding in the usual way. This expedient makes the receiver both a continuous range and a bandspread device. The aerial, first-detector and oscillator coils are all plugged in as a unit.

AUTO "B" ELIMINATOR

(265) Mr. Kenneth Gray, Hamilton, Ont. (Q.) This is the first time I have sent you a letter and it is to request you to give me an article on a "B" eliminator for a car radio set. At present I have a set operated by batteries, but I would greatly appreciate an article on this subject before long.

(A.) While it is possible for an amateur to construct a "B" power unit for a car radio set, there are two definite reasons why this is not practical.

First, the circuit arrangements are such that if the vibrator sticks (and they have a bad habit of doing this even in well designed manufactured units) a very heavy, continuous load is placed on the car battery which will very likely ruin it unless the short is rectified within a very short time.

Second, well designed and constructed units are available at such reasonable prices that it is not worthwhile for the constructor to go to the trouble of making one, which probably would not be as good as a manufactured one.

(In spite of these objections, we expect to print in a forthcoming issue of RADIO-CRAFT the data on a vibrator-type "B" unit of simple design, which the experimentally-inclined radio man may find pleasure in building—even if, as previously stated, it may be economically impractical in the long run.)

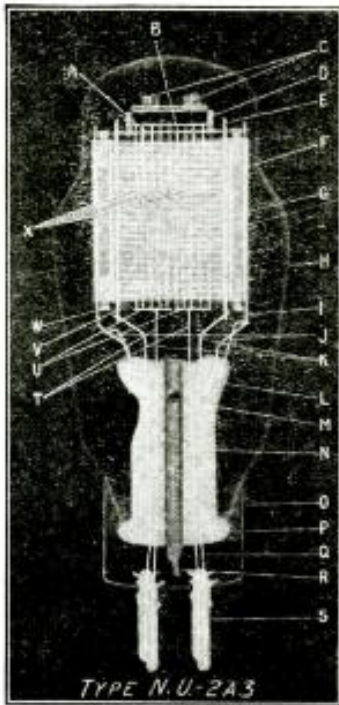

Reproduction from x-ray photo. Consistent detail accuracy in National Union tubes is one reason they are sold by more service men than any other make. Parts of this tube are: a. Top Mica; b. Top Fil. Support; c. Spiral Fil. Hooks; d. Fil. Hook Support and Fil. Guide; e. Control Grid Support; f. Plate; g. Control Grid Lateral; h. Bulb; i. Plate Weld; j. Getter Flag Supports; k. Grid Welds; l. Stem Press; m. Exhaust Hole; n. Exhaust Tube; o. Basing Cement; p. Bulb to Stem Seal; q. Lead Wire; r. Exhaust Tube Tip; s. Base Pins; t. Fil. Welds; u. Fil. Supports; v. Bottom Mica; w. Mica Straps; x. Fil. Strands.

X-RAY REVEALS NATIONAL UNION RADIO TUBE ACCURACY-QUALITY

Servicemen Everywhere Acclaim Fine Tubes—Free Shop Equipment

Many thousands of service experts throughout the United States are finding it profitable to be tied-up with the National Union program. They have proven to their own complete satisfaction that National Union means more than—Radio Tubes, National Union stands as a symbol of more service business and better service business at a profit. No service man who appreciates the full significance of what National Union can mean to his success can possibly afford not to tie-up with the National Union program. Resolve now to tie-up with National Union in your own best interests.

FREE SHOP EQUIPMENT

One of the principal objectives of National Union has been to supply the serviceman with modern shop equipment and data so that he would be in a position to do better service work and more of it at a profit. Testers, analyzers, service manuals and service tools are given with the purchase of National Union tubes. The wide awake dealer realizes the advantage of obtaining his equipment in this way as he has both the guarantee of the manufacturer and the backing of National Union.

National Union offers include: Servicing Tool Kit, Supreme No. 333 Analyzer, Service Manuals—Auto Manual, Triplett Oscillator and Output Meter, Triplett Tube Tester, Hickok Diamond Point Jr. Tube Tester, Supreme Model 85 Tube Tester. All Offers, subject to withdrawal without notice. Small deposit. What do you need? Get details!

National Union Radio Corporation of N. Y. RC-6
400 Madison Avenue,
New York City.



Gentlemen:

I am interested in:

Name

Street

City

State

WEBSTER - Chicago

Portable Public Address Systems

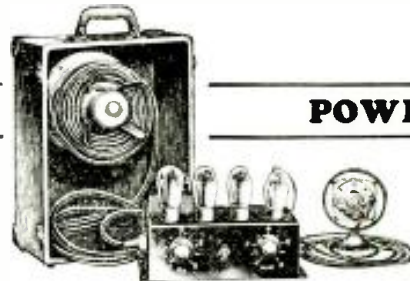

COMPACT

POWERFUL

WEBSTER - Chicago PA-42

A Powerful Public Address System
Reasonably Priced to Meet Competition.
Quality for Performance. *Send for Circular.*

THE WEBSTER COMPANY

3830 West Lake Street

Chicago, Illinois

POSTAL BOOSTER

GUARANTEED TO IMPROVE S. W. RECEPTION



Something the Short Wave Fan has been waiting for, for a long time. The Postal Short Wave BOOSTER will increase the sensitivity and selectivity of your present receiver over 300%. It eliminates repeat spots, image frequencies and lowers the background noise considerably.

If you are interested in hearing foreign stations you could never hear before—

IF you have difficulty in separating stations on the 19, 31, 19, 16 meter and all amateur bands—IF your background noise is too high—IF you are troubled with stations repeating on different points of the dial—Do not hesitate—Purchase a POSTAL PRE-SELECTOR AND BOOSTER.

CONSTRUCTION

Each Postal BOOSTER is actually laboratory constructed, tested and calibrated. It employs 2-78 pentodes, 1-25Z5, uses the new drawer coils and is

entirely self-powered. It is equipped with a gain control, switch to cut the BOOSTER in and out of the circuit, and an illuminated aeroplane dial for the main tuning control. It is mounted in a beautiful sturdy crystal finished shielded cabinet with rubber legs and measures 8 1/2" x 9 1/4" x 6".

SIMPLE TO OPERATE

The Postal BOOSTER can be connected to any set in less than a minute. No tools or soldering necessary. THE POSTAL BOOSTER WILL IMPROVE RECEPTION ON ALL SHORT OR ALL-WAVE RECEIVERS, regardless of the make or the price you paid. Sold with a money-back guarantee. Operates from either A.C.D.C. or battery. Similar instructions furnished with each unit. Prompt deliveries.

SPECIAL PRICES

Sold completely laboratory constructed and calibrated with one drawer for any band... \$19.95
 Matched set Sylvania 2-78, 1-25Z5 tubes... 2.95
 Drawer coils available for (14 to 29) (29 to 55) (55 to 90) (90 to 200) (200 to 300) (350 to 550) meter bands, each drawer... 3.95

135-K LIBERTY ST.
POSTAL RADIO NEW YORK N. Y.

The SHURE TECHNICAL BULLETIN

is valuable in your library.

Devoted to the advancement of microphone technique, this monthly publication of Shure Brothers Company, *Microphone Headquarters*, contains authoritative and useful information on technical phases of broadcast and sound engineering, design data, new applications of microphones.

- These back issues are available at 6c per copy:
- No. 1 Condenser vs. Two-Button Microphones
 - No. 2 Field Problems in Microphone Placement. Part I—Broadcasting
 - No. 3 Field Problems in Microphone Placement. Part 2—Public Address
 - No. 4 Mixing Circuit Design Data
 - No. 5 The Microphone—An Electric Ear. Noise Measurements—Binaural Transmission
 - No. 6 Field Problems in Microphone Placement. Multiple Microphone Systems
 - No. 7 Electro-Acoustic Measurements of Microphone Performance
 - No. 8 High Quality Sound Reproduction. An Outline of Factors Affecting Fidelity
 - No. 9 The Truth About Microphone Response Characteristics
 - No. 10 Transformers for Speech Input Circuits.
 - No. 11 Amateur Radiophone Transmitters. —Part I

SHURE BROTHERS COMPANY
 215 W. Huron Street, Chicago, Ill.
 Send me postpaid the following issues of the SHURE TECHNICAL BULLETIN:

- ... No. 1 ... No. 2 ... No. 3 ... No. 4
 ... No. 5 ... No. 6 ... No. 7 ... No. 8
 ... No. 9 ... No. 10 ... No. 11
 (6c per copy)

... Enter my subscription for one year. (Price 50c)

I am enclosing c. in stamps
 cash money order.

Name

Address

City and State R. C. 634

Have You Seen ELECTRAD'S 10-WATTER?

It's a corker—and low-priced!
 Wire-wound, vitreous-enameled, and has non-corrosive Monel metal contacts and lugs. Same type in 3 sizes, 3 ratings and 67 values.

Write for New Catalog "RC-6"

175 Varick St., New York, N.Y.
ELECTRAD

OPERATING NOTES

(Continued from page 781)

Returning to the shop I sat around about an hour wondering if this A.K. job was all I was going to get; but no, the phone rang and it was a call from a customer about 10 miles away. As I do not make any repairs in the field, I grabbed my tube tester, tubes and tools and pushed the old Liz up the road as fast as it would go.

BRUNSWICK 17

THE complaint in the set, a Brunswick 17, was that it continuously played loud enough for the entire neighborhood—the volume control, R, in Fig. 3B, did not have any effect. After testing the tubes I found that they checked O.K. and told the lady that I would have to take it to the shop for further checking.

In the shop, and with a high-quality analyzer at my finger tips, everything checked all right. I replaced the A.V.C. tube with a NEW tube, but still no control of the volume. After about an hour I again tried some more tubes. Finally, after about a dozen tubes were tried, I found one with the correct characteristics and the set worked all right. (This was the most stubborn case of receiver trouble caused by incorrect tube characteristics of any that I have ever run across.) I returned the set to the owner and received \$4.05, as I charge 5c a mile for handling.

After having lunch I went to the post office to secure some parts I had ordered, including some No. 30 enameled wire for re-winding voice coils. I had a Crosley coil to rewind, so I then got busy and re-wound the coil, returning it to the owner and collecting \$4.00.

Later in the afternoon a man came in with a complaint concerning a Majestic 210.

MAJESTIC 210

HE SAID, "the set will not work and the big tube gets red hot." I told him that no doubt the filter condenser had broken down (this model uses two 8 mf. dry electrolytic condensers), and that I would have to bring it to the shop for repairs. He wanted to know whether I would guarantee the job, as he had recently paid one Service Man \$7.25 for a condenser job. I told him I would guarantee the condenser, C, in Fig. 3C, that I would put in, for 90 days, as I guarantee all my parts for that length of time.

When I arrived at his house I discovered that the lights fluctuated, whereupon I advised the owner that I could not guarantee the job unless I put a voltage regulator on the radio set, because of the faulty line supply. He agreed to have this work done, so the receiver was returned to the shop and the necessary repair affected. I charged him \$9.50 for the job.

This gave a total of \$24.85 for the day. It is not every day that this much work is done, and neither is it the most work that has been done in a day, but the figure gives an idea what the small-town man has to do for a living.

I do not know how these charges apply to other sections of the country but there is no complaint here. It is vitally necessary that all work be the best, as bad news travels fast in a small town and it is necessary to get repeat business in a small town to make a living. Word of mouth advertising is the best (or worst) advertising that a radioician can get so I try to please everybody, even if I lose money on an occasional job.

I might also add that I keep a perpetual stock inventory and buy parts whenever I need over \$3.00 worth. In this way my supply expenses are never heavy one month and light the next unless business rises or falls. In other words, I try to keep my expenditures on a percentage basis in proportion to my income.

I use a claim check that serves two purposes: (1) it acts as an invoice of the repair bill; and, (2) when signed it gives me a record for future reference—also, it notifies the customer that all repairs are cash!

Although the preceding information is general, it just shows what is done in my shop and it might help someone who is figuring on starting a shop in a small town.

I keep about 50 tubes of all kinds and a stock of parts which generally have to be renewed. An elaborate test panel is not good business for the small-town man as his volume of business will not justify the expenditure of over \$150.00 for test equipment. An analyzer, tube tester and oscillator are ESSENTIAL and they should be of good quality.

As to advertising, I use only a form card similar to those which have been shown in past issues of RADIO-CRAFT, as I have not been able to see any results from newspaper and other methods; I repeat, a satisfied customer is the best advertising.

Hope to hear from some other country radio doctors in the near future.

WARREN K. PENDRY.

ADDITIONAL DATA ON PENTODE CIRCUIT TROUBLES

C. A. Goditus

(In an article entitled, "What Is Wrong With Our Pentode Circuits?" which appeared in the October, 1933 issue of RADIO-CRAFT, pg. 242, many interesting points in the operation of pentode tubes were discussed. Editor)

IN THE previous article on type 47 pentode troubles, it was seen that after being in use for several months, the tube would become an oscillator if the load impedance was of proper design (7,000 or 8,000 ohms for maximum undistorted output). Under this condition the music is just about audible and a hum is present. This happens after the set is in operation about ten minutes, or sooner if a load static discharge or line noise causes the control-grid to go positive. Cures were outlined in Figs. A, B, and C, permanently eliminating oscillation in such circuits.

More information was uncovered, both in sets having high load impedance and in sets having low impedance. Sets with high load impedance are troubled with hum, distortion, and cutting-off; sets with low load impedance are troubled with hum and distortion only.

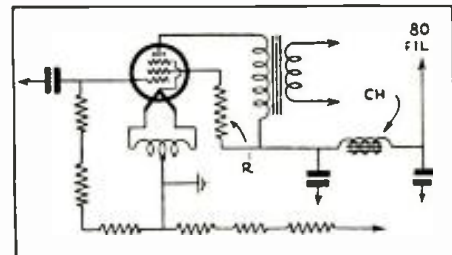
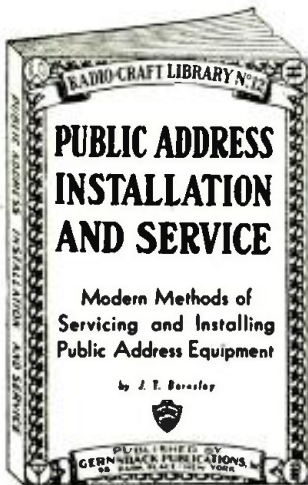

Fig. 4

The Unit R here is an oscillation suppressor.

NOW READY

This New Book!



Every Service Man Needs This P. A. Book

Here is the new edition to the RADIO-CRAFT Library Series—it's a book which shows radio men how to really make extra money in a fast-growing field, allied to radio. In public address work unlimited opportunities arise—it's practically a rejuvenation in radio. Know the facts about public address equipment and get your share of business. Get a copy of **PUBLIC ADDRESS INSTALLATION AND SERVICING**, by J. T. Bernsley—it covers modern methods of servicing and installing public address equipment.

A Brief Summary of the Contents

AUDIO AMPLIFIER FUNDAMENTALS—

Introduction; Discussion on types of amplification—transformer coupling, resistance coupling, impedance coupling, push-pull and miscellaneous; New Terms and Theory—Class A amplification, Class B amplification, Voltage amplifier; Power amplification—Pre-amplifier, Carbon microphone, Condenser microphone, Ribbon or velocity microphone; Power Supply Requirements—For Class A, For Class B.

PUBLIC ADDRESS AMPLIFIERS—

Standard Installation— $\frac{1}{2}$ watt amplifier, 7 watt amplifier, 10 watt amplifier, 15 watt amplifier, 20 watt amplifier, 30 watt amplifier, 40 watt amplifier, 50 watt amplifier; Special Installation—Portables, Mobile-use Amplifiers.

INSTALLATION INSTRUCTION—

Analyzing Requirements; Best methods for installing—indoor, outdoor; Methods for minimizing "howl" or audio oscillation present after installing; Speaker Installation (horn type, baffle type); General Instruction and Hints.

ACOUSTICS—

How to survey and analyze an auditorium for reverberation time—with formulas, and correct method for treatment; chart with absorption coefficients of standard treating material.

SERVICING—FORMULAS—

Amplifier; Power Supply devices; Speakers; Microphones (carbon condenser, ribbon or velocity); Formulas.

**64 Pages—6 x 9 Inches—
Over 50 Illustrations**

This book can be bought in combination with other books in this series—see page 708.

GERNSBACK PUBLICATIONS, Inc.
96-98 Park Place New York, N. Y.

MAIL THIS COUPON TODAY!

GERNSBACK PUBLICATIONS, Inc.
96-98 Park Place, New York, N. Y.

Gentlemen: Enclosed you will find 50 cents, stamps, checks or money order accepted, for which send me postage paid, One Copy of the new book, **PUBLIC ADDRESS INSTALLATION AND SERVICING**.

Name
Address
City State RC-634

PHILCO 70 AND 90

THE SETS with high load impedance cut off due to the 47 tube circuit going into oscillation. It was also found that if too low a filament voltage was used in high-impedance sets, they cut off very easily. A low filament voltage is the same as saying the tube has a low emission, also a reduced mutual conductance, making the tube circuit oscillate more readily. Philco 70 and 90 models having 2.1 V. on the pentode filament at 110 V. A.C. line, are the bad actors. Their pentodes go into circuit oscillation very easily.

Pentode tubes of the 47 type should be put in circuits using resistance-coupled inputs under the following conditions only: the grid resistance should not exceed 50,000 ohms if grid bias is obtained from part of the voltage divider; the grid resistance should not exceed 0.5-meg. if grid bias is obtained by a resistor in the plate-return lead. Transformer coupling is recommended, due to the low D.C. resistance of the secondary, as compared to a grid leak.

We are concerned about grid resistance because in the 47 type, the control-grid is mounted closer to the filament than in any other high-current tube; also, the screen-grid is very close to the control-grid. When operating the filament at 2.5 V. at 1.75 A., the screen-grid current is 7.5 ma. and the plate current is 32 ma., the screen-grid having a red color at this current. The control-grid is in very close quarters; the heat, due to watts power dissipation in the tube because of filament, screen-grid and plate currents, is conducted to the control-grid, making grid emission possible. This is very noticeable in every tube after it has seen several months of use, sometimes only a week after it is put in service.

This grid current, I, times the grid leak resistance, R, gives a voltage drop which is out of phase with the source of grid bias at the voltage divider, the resultant grid bias being less negative, permitting a greater flow of electrons from filament to plate and screen-grid. This causes more watts dissipation, more heat, and in turn more grid emission; this increases the I x R drop, with resultant still less grid bias. This cycle of events takes place until the resultant grid bias is eventually zero. It is impossible for the control-grid to become positive because electrons would be attracted to the grid, causing a drop across the grid leak in the opposite direction.

As the plate and screen-grid current values are excessive under these conditions, there is considerable heat dissipated in the tube, causing the screen-grid to get almost white hot; the filament emission also increases from this extra heat. This takes place until the tube is damaged to the extent where it becomes a weak tube, having low plate and screen-grid currents, and not enough heat is present in the tube to cause grid emission.

In Fig. 4 is shown a part of the circuit of a Philco 90, which uses a single type 47 tube; suppression resistor R, 2,000 ohms, deprives the screen-grid of some voltage and also lowers the screen-grid current. When some grid emission takes place the resultant grid bias is less negative, the screen-grid and plate currents tend to increase, and then there is an increased drop across R, which makes the screen-grid voltage lower. A point is finally reached where the drop across R does not allow the grid to become too low a negative value, and does not allow the plate current to increase above its rated current, being impossible to damage the tube, or cause hum and distortion. (Although the screen-grid voltage becomes low and the plate voltage increases, there is no drop in amplification, nor is the tone impaired.)

STEWART-WARNER AND ATWATER KENT

THIS grid-current trouble also will be found in such sets as Stewart-Warner, Atwater-Kent, and others using high values of grid resistance and high values of screen-grid and plate voltages. (Note that RCA Victor employs transformer input exclusively, and that they do not have grid-current trouble in their set models.)

C. A. GODDIE'S

(Continued on page 756)



**Make Quicker,
More Accurate Tests
with this NEW No. 1167**



DEVELOPED by some of the industry's outstanding engineers, the new Triplet No. 1167 instrument is arousing widespread interest. While simply designed and easily operated, its extreme accuracy and completeness satisfy the most exacting requirements of the professional service man.

With this new instrument, you can quickly and accurately measure voltages, current, resistances and continuities without removing the chassis from the cabinet . . . using the cable and plug to make the connections between the set socket and the tester.

The 1167 unit incorporates a direct-reading Ohmmeter, Output Meter, AC-DC Voltmeter and Milliammeter. All readings are controlled by a selector switch. The Voltmeter has 1000 ohms per volt resistance. Voltage readings: 15-150-750 — Milliamperere readings: 0-1.5-15-150 — Ohmmeter readings: 0-1500-150,000-3,000,000 ohms. Dealer's net price \$25.00.

The above two-unit tester is also furnished in a three-unit combination, No. 1179 containing an oscillator for broadcast receivers at \$34.67 net, or the new No. 1181 with an All-Wave oscillator at \$38.00 net.

With this combination of precise measuring equipment, the service man will have a compact, portable laboratory at his command for every servicing need. Order from your jobber today.

**THE TRIPLIET ELECTRICAL
INSTRUMENT COMPANY**

60 MAIN STREET BLUFFTON, OHIO



Mail Today For Details

THE TRIPLIET ELECTRICAL INSTRUMENT CO.
60 Main St., Bluffton, Ohio

Gentlemen:
Send me catalog on Triplet Instrument No. 1167,
and your complete line of radio servicing instruments.

Name

Street Address

City State

Check Shorts! RADOLEK'S "Build It Yourself" New A.C. Tube Short Checker

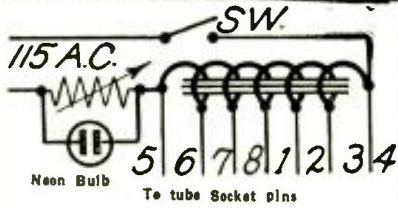

- For 4, 5, 6 and 7 prong tubes
- Catches all Inter-element Shorts

Essential Parts Supplied by Radolek: 1—Tapped Choke, 1—Special Variable Resistor, 1—Neon Bulb, 1—4, 5, 6 Hole Tube Socket, 1—7, 7 Dual Seven Socket, 1—Neon Bulb Socket, and Plans for Insulating. Regular Value of Parts \$4.55.
YOUR SPECIAL PRICE\$4.00

Theory: A shorted Tube Element will cause a circulating current in one portion of the tapped choke which acts as an Auto-Transformer, changing its impedance from that which balanced the Variable Resistor to a negligible quantity, thus causing a high voltage across the Neon Bulb—indicating a shorted tube.

RADIO DEALERS AND SERVICEMEN: Write for your copy of the New 1934 RADOLEK PROFIT GUIDE! Kindly enclose your business card or use your letterhead when requesting our Catalog.

The Radolek Co.
DEPT. 133 601 W. RANDOLPH
CHICAGO, ILL.

Dependable Sensational Performance!

BUD

Laboratory-Built
P. A. Equipment

5 DAYS FREE Trial

Try BUD Sound Equipment For Five Days Absolutely Free!

ELECTRO-DYNAMIC UNITS
CARBON AND CONDENSER
MICROPHONES • 4 & 6 FT.
ALL ALUMINUM TRUMPETS
FIELD EXCITERS • AIR COLUMN
HORNS • LOW AND HIGH
FREQUENCY UNITS FOR WIDE
RANGE THEATRE USE

We invite careful, critical inspection of our entire line of BUD laboratory built sound equipment. We suggest that you conduct your own comparative test. We CHALLENGE you to duplicate BUD performance and BUD DEPENDABILITY AT ANY PRICES! Write today for descriptive literature and prices and details of our FREE FIVE DAY TRIAL offer.

BUD SPEAKER CO.
1121 JACKSON ST.
TOLEDO, OHIO—U.S.A.

Get the finest

RESISTORS SUPPRESSORS CONDENSERS

Servicemen, experimenters and manufacturers alike, throughout the world, rely upon Continental for quality and service unsurpassed. New catalogs show complete lines of resistors, auto-radio suppressors, and condensers.

Ask Your Jobber or Write

CONTINENTAL CARBON Inc.
1314 LORAIN AVE. CLEVELAND, OHIO

THE UNI-SHIELDED THREE

(Continued from page 735)

battery. Of course, the correct voltage reducing resistor will have to be used with each particular type of "A" supply to bring the voltage down to the required 2 volt value. For example, a 7-ohm resistor will have to be used in series with an air cell battery or with a single cell of a storage battery; a 3 ohm resistor will be needed in series if two 1½ volt dry cells are used, etc. The total filament current is only .38-A. and this drain is so light that even the 1½ volt dry cells should last a long time without requiring replacement. Three 45 volt "B" batteries are required and 13½ volts of "C" battery. Only .02-A. is drawn from the "B" batteries. Hence, this set is extremely economical in operation.

The Circuit

It will be noted that the antenna is connected directly to the R.F. tube, V1. That is to say, the signal is impressed directly upon the grid of V1, dispensing with the antenna coil or coupler.

Tuning is accomplished by means of a 140 mmf. variable condenser C6 shunted across a plate impedance coil L1. The latter constitutes the longer winding, L1, of a special four-prong, plug-in coil. The shorter winding of this coil, L2, serves as a tickler, being connected in series with the plate of the detector tube V2. The regenerative action thus obtained is very strong. Regeneration is controlled in the conventional (that is, for screen-grid tubes) manner, by varying the screen-grid voltage of the detector. The potentiometer R4 is used for this purpose. This method of control is smooth and effective.

The short-wave plug-in coil is of special design. Four of these coils are used to cover the band from 15 to 200 meters (20,000 to 1500 kc.). A feature of the coils is the band-spread effect attained through proper design and the use of shielding.

Values of 100 mmf. for the grid condenser C7, and 10 megohms for the grid leak R3 have been found to give best results. However, in some cases it may be desirable to use a smaller grid leak, such as a 5 or even of a 3 megohm unit.

The 2½ mhy. R.F. choke, R.F.C., serves to block off R.F. currents from the audio circuit. Those currents are bypassed through the .001-mf. mica condenser, C8. Values both for the R.F. choke and of the bypass condenser have been calculated carefully for high-frequency reception and should be adhered to for best results. The use of an audio plate choke at C9, adds immensely to the efficiency of the receiver, permitting a higher plate voltage on the detector and thus increasing the sensitivity to an amazing extent.

Since the output amplifier pentode V3 uses a "C" battery for negative grid bias, a grid resistor R7, having a value of .5-megohm, is used. The conventional .02-mf. coupling condenser, C1, is employed between the detector and the audio stage. The 33 output tube has an undistorted power output of 700 milliwatts. This tube is capable of producing considerably greater power output than three-electrode power amplifiers of the same current drain. Furthermore, the 33 has greater amplification than is possible in a three-electrode amplifier, without serious sacrifice in power output. The power-handling ability of the 33 tube is made possible by the addition of both a suppressor-grid and a screen-grid between the grid and plate. The suppressor is placed next to the plate and is connected inside the tube to the filament.

The .001-mf. condenser, C11, improves tone quality since it bypasses certain of the harsh or scratchy higher audio frequencies which are often especially noticeable with pentode output tubes. The triple-spring open-circuit Jack J1 permits earphones or loudspeaker to be plugged into the output circuit as desired. When the plug is inserted in the jack, this also automatically closes a second circuit between "B" minus and the chassis. The jack is insulated from the chassis.

Unique Chassis Design

This set derives its name from its unique chassis design. The chassis, panel, and

The Breakers

ON THE OCEAN FRONT

ATLANTIC CITY, N. J.

Situated directly on the Boardwalk and convenient to all Piers and Amusements

PER DAY per person	\$6.00	With Meals Private Bath
EUROPEAN PLAN	\$3.00	Private Bath

Hot and cold sea water in all baths
Excellent Food—French Cuisine

Garage

EMANUEL E. KATZ, *Man. Director*

CLASSIFIED ADVERTISEMENTS

Advertisements in this section are inserted at the cost of twelve cents per word for each insertion—name, initials and address each count as one word. Cash should accompany all classified advertisements unless placed by a recognized advertising agency. No less than ten words are accepted. Advertising for the July, 1934, issue should be received not later than May 5th.

FARM RADIOS

NEW "DRY CELL" ALL-WAVE RADIO. Coast to coast reception. Cost 10c weekly. 20th Century Co., B-2493, Kansas City, Mo.

INSTRUCTION

RADIO HOME STUDY COURSE—FAMOUS RADIO Doctors Course; 58 lessons, over 500 illustrations with supplementary service data and genuine blue prints. Hundreds sold for \$79.50. Complete course shipped prepaid \$7.50. Examinations included, but not corrected. Order now. Supply limited. Liquidating Agent, Eugene Parker, Pierce Ave., Salem, Mass.

RADIO

TRANSFORMERS AND SPEAKER FIELD COILS REWOUND or made to order. Transmitting power transformers. All types of coils wound. Send for circular. Red Arrow Radio Products, 2301 Grand River, Detroit, Michigan.

SONGWRITERS

SONGWRITERS! POEMS, MELODIES, AMAZING OPPORTUNITY. Hibbeler, D153X, 2104 Keystone, Chicago, Ill.

SEXOLOGY

THE MAGAZINE OF SEX SCIENCE

SEXOLOGY, foremost educational sex magazine, is written in simple language and can be read by every member of the family. It is instructive, enlightening—not a risqué book—contains no jargon. Contains 25 important articles on Sex Science, 68 pages, with attractive two-color cover. Here are a few of the more important articles:
Editorial—"Sex Sins"; Children with Tails (Illustrated); Sexual "Depressants"; Foreign Bodies in the Vagina (Illustrated); Sterilization of Men and Women (Illustrated); Inheritance of Disease; Men Who Are Not Men (Illustrated); Contraceptives and Science (Illustrated); Birth Customs of Savages (Illustrated); The Awakening of Sexual Life (Illustrated); Signs of Previous Pregnancy; Your Unborn Child (Illustrated); Impotence in Young Men; A Mother at Twelve (Illustrated).
Get a copy of SEXOLOGY on any newsstand, or, if your dealer cannot supply you, send 25c in stamps for a copy of the current issue.
SEXOLOGY, 25R West Broadway, New York, N. Y.

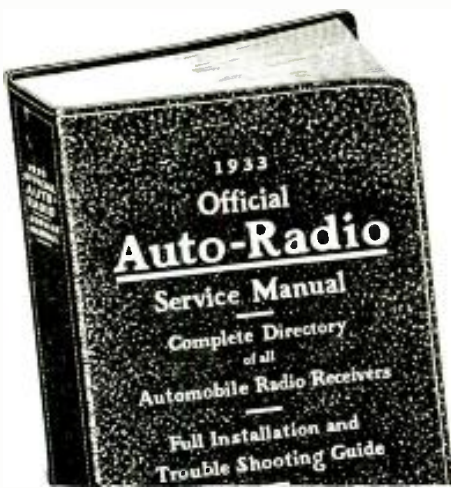

FREE

48-Page Supplement to the Auto-Radio Service Manual!

To everyone who now purchases the OFFICIAL AUTO-RADIO SERVICE MANUAL this big 48-page Supplement is issued FREE. Practically all of the latest sets, together with servicing information will be found in these new pages. The new Supplement does not increase the cost of the book to you, but gives you an Auto-Radio Service Manual that is right up-to-the-minute with service notes.

Good Money in Servicing Auto-Radios

If you are overlooking servicing auto radios, you're missing a great deal of business. The auto-radio business had its greatest boom last summer when thousands of sets were sold. By now many of these same sets require servicing and with hundreds of them right in your own community, you can build up a good auto-radio servicing business. In a short time you can easily add 25% or more to your regular servicing business.

List of Sets Covered in the Manual

- | | |
|-------------------------------|---------------------------------|
| Acme Radio Mfg. Co. | P. R. Malloy & Co. |
| Allied Radio Corp. | Melloni Radio Mfg. Co. |
| Atwater Kent Mfg. Co. | Montgomery Ward & Co. |
| Audiola Radio Co. | National Co., Inc. |
| Autoerat Radio Company | Nobilit-Sparks Ind., Inc. |
| Automatic Radio Mfg. Co. | Philco Radio & Tel. Corp. |
| Carter Genemotor Corp. | Pierce-Alro, Inc. |
| Century Radio Prods. Co. | Premier Electric Co. |
| Chevrolet Motor Company | Radio Chassis, Inc. |
| Consolidated Industries, Ltd. | RCA-Victor Co., Inc. |
| Crosley Radio Corp. | Sentinel Radio Corp. |
| Decca Appliance Corp. | Sparks-Wilmington Corp. |
| Detroit Radio Corp. | Stewart Radio & Tel. Corp. |
| Emerson Electric Mfg. Co. | Stewart-Warner Corp. |
| Fada Radio & Elec. Corp. | Stronberg-Carlson Tel. Mfg. Co. |
| Federated Purchaser, Inc. | Transducer Corp. of Am. |
| Ford-Majestic | United Amer. Bosch Corp. |
| Franklin Radio Corp. | United Motors Service |
| Galvin Mfg. Corp. | U. S. Radio & Tel. Corp. |
| General Electric Co. | Union Radio Prods. Co. |
| General Motors Corp. | Wells-Gardner Company |
| A. H. Grebe & Co. | Wholesale Radio Serv. Co. |
| Grisby-Grunow Co. | Rudolph Wuritzer Mfg. Co. |
| Has. Hoodwin Company | Zenith Radio Corp. |
| International Radio Corp. | |

\$2.50

Over 200 Pages
Over 500 Illustrations
9 x 12 Inches
Flexible, Loose-Leaf Cover

Mail This Coupon Today!

GEINSBACK PUBLICATIONS, Inc. RC634
96-98 Park Place, New York, N. Y.

Enclosed you will find my remittance of \$2.50 for which please send me One Copy of the 1933 OFFICIAL AUTO-RADIO SERVICE MANUAL with FREE 48-page Supplement. Send remittance in check or money order. Register letter if it contains cash or currency. WE PAY POSTAGE.

Name
Address
City State

shielding are in one piece, as shown in the photographs. In effect, this results in a sloping panel of pleasing appearance, a "U" shaped shielded well for the three tubes and the plug-in coil, and also effective shielding for the parts beneath the chassis. This design dispenses with extra shielding and, moreover, is efficient, rugged, compact, and economical. The chassis will readily slide into a metal or wood carrying case and presents a neat, attractive appearance.

While the receiver has sufficient power to operate a loud-speaker on many stations, it was purposely designed to have high R.F. sensitivity so as to bring in the hard-to-get foreign stations on earphones. In other words, instead of increasing expense and complicating the circuit by the addition of A.F. stages, the designer concentrated on producing a simplified circuit, actually capable of bringing in extreme DX with sufficient power to be heard readily on a good pair of earphones. With the ordinary three-tube short-wave receiver, this condition is generally reversed, as most such receivers are designed with a "showy" audio system, but with a relatively weak R.F. circuit which falls down badly when it comes to bringing in real distance.

Operation is easy since the set is perfectly stabilized and more than amply bypassed. Naturally, a certain amount of skill and experience is needed to bring in low-power foreign stations, but there is nothing tricky about the tuning or the regeneration control.

In constructing the receiver, the four sockets are mounted first. Then, the jack J1, plate choke Ch., tuning condenser C6, and switch Sw. 1 are mounted on the front panel. As mentioned above, the jack must be insulated from the panel by fiber washers. The twin binding post, BP1, BP2, are mounted on the rear panel.

The R.F. choke, R.F.C., is fastened beneath the chassis between the sockets provided for L1 and V2. The other small parts, which include carbon resistors and mica and cartridge condensers, are soldered in place while the set is being wired. In proceeding with the wiring, the grid circuits should be wired first, then the plates, next the filaments and finally the various bypass condensers. The positive filament terminals of the tube sockets may be grounded directly to the chassis—also the ground terminal BP2, the spring contact of jack J1, and the returns of the bypass condensers. The "A" plus lead of the cable is also grounded to the chassis, as well as one end of the volume control potentiometer R4.

After the wiring is completed and checked, the cable should be connected to the batteries in preparation for the initial test. Tubes, earphones, and one short-wave coil are plugged in, and antenna and ground are connected. The coil covering the band up to 200 meters should be used for the first test. The regeneration control R4 is turned until the detector tube circuit oscillates. Then a station whistle is tuned in. Turning back the regeneration control slightly to the point just before the set "spills over" clears up the whistle and brings in the desired station loud and clear.

List of Parts

- Three Trutest .1-mf., 400 V. cartridge condensers, C2, C4, C9;
- One Trutest .1-mf., 200 V. cartridge condenser, C3;
- One Trutest .25-mf., 200 V. cartridge condenser, C5;
- One Trutest 140 mmf. variable condenser, C6;
- One Aerovox 100 mmf. mica condenser, C7;
- One Aerovox .001-mf. mica condenser, C8;
- One Trutest .02-mf., 200 V. cartridge condenser, C1;
- One Aerovox .001-mf. 600 V. cartridge condenser, C11;
- One Trutest 10 meg., ½-W. carbon resistor, R1;
- One Trutest 40,000 ohm, ½ W. carbon resistor, R2;
- One Trutest 10 meg., 1 W. carbon resistor, R3;
- One 50,000 ohm potentiometer, R4;
- One Trutest 50,000 ohm, ½ W. carbon resistor, R5;
- Two Trutest .5-meg., ¼ W. carbon resistors, R6, R7;
- One three spring open circuit jack, J1;
- One twin binding post, BP1, BP2;

FORDSON LEADS AGAIN!

SENSATIONAL NEW 4 TUBE ALL-WAVE RADIO

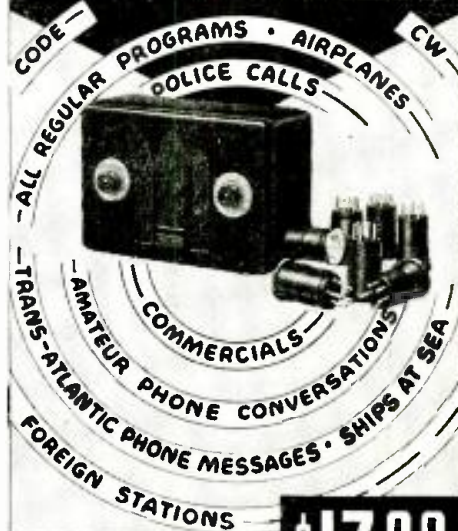

FREE 30-DAY TRIAL **\$17.00 COMPLETE**
WITH THIS SPECIAL OFFER FOR A LIMITED TIME!

For the first time, a 4-tube ALL-WAVE A.C.-D.C. all-purpose set! Operates anywhere, with adapter can be used on car, boat, farm light plant, summer cottage; 2, 32 and 220 volts. Radio amateur's find it ideal, with remarkable band spread, fine reproduction! Tunes 15 to 2700 meters (110 to 20,000 kc.). Unusual ability to get results on CW; covers all broadcast bands. Efficient built-in aerial gives outstanding performance with our All-Wave Aerial; Dynamic speaker. Complete with RCA-Flemingham latest-type tubes. 100% licensed.

To Get It At This Price You Must ACT AT ONCE!

We reserve right to withdraw this offer in reasonable time. To buy now (at less than half retail!) ORDER NOW. Order right from ad with confidence that you get a Fordson guaranteed radio, with 30-day FREE TRIAL in your honor. (Send Money Order or certified Check for prompt shipment.)

Complete Line—Amazing Prices!

There is a Fordson guaranteed radio for every need! A.C.-D.C.; Dual Wave; All-Wave; Battery; beautiful Consoles; for home, farm, foreign. From 2000-mile range midsets that get police calls to 8-tube World-Wide receivers. Fine Gothic and Modernistic cabinets to choose from. Special 4-Tube Auto Radio—get our specifications before buying a set for your car! Send today for our big, new FREE catalog!

Prices from \$9.45 up

Money-Making Opportunity!

Just showing this Fordson to friends resulted in TWELVE orders for one owner in first few weeks. He gets big profit on every sale. You can make your Fordson pay its way in Orders. Part or full-time offer. Samples free.



MAIL COUPON NOW

FORDSON RADIO, Inc., Dept. 6-38
Oakman Bldg., Detroit, Mich.
Send me new FREE catalog and agent offer (this is NOT an order.)
Name
Address
City State

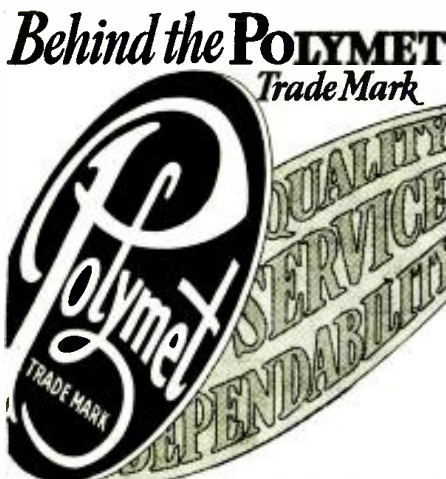

Many leading manufacturers, in both the radio and electrical industries, have come to recognize in POLYMET Products that quality, so essential to dependability. THEIR ENGINEERS DO NOT GUESS—THEY KNOW.

The successful service man does not guess, he knows that the use of POLYMET Products in replacement work is his guarantee of satisfaction.

Polymet Condensers

ELECTROLYTIC

Wet and Dry Types
PAPER

- Pe-Tite Tubular
- Hi-Volt in Cans
- Uncased Sections
- Oil Condensers (Transmitting and Industrial uses)

MICA

All Types—Midget sizes with lugs or leads. Large type for industrial uses.

TRANSFORMERS

WIRE WOUND RESISTORS

Write for 1934 catalog now

POLYMET MFG. CORP.

833-R East 134th St. New York, N. Y.

NEW! SENSATIONAL!

110 VOLTS AC FOR AUTOS

The new AUTONATOR generates 110 Volt A.C. Current in motor cars, aeroplanes and from all types of engines and motors, direct from fan belt. Costs nothing to operate. No service—no brushes, collector rings, commutator or wire wound armature. Ideal for operating PORTABLE Sound Equipment, A.C. Radio Sets, Neon Signs, Electric Lights, Searchlights. Send for complete details.

AUTONATOR LABORATORIES, INC.
8440 South Chicago Ave. Dept. A Chicago, Ill.

COMPLETE ELECTRIC PLANTS



\$99

ONAN A.C. PLANTS furnish same current as city service. Operates Radio, Water System and Household Appliances.

SIZES 300 WATTS UP

Models low as \$99. No battery. For farms, lake homes, commercial purposes, public address. Some dealer's territory available.

D. W. ONAN & SONS
Minneapolis, Minn.

950 Royalston Avenue

TODAY'S PROFIT OPPORTUNITY

INVESTIGATE MOTION PICTURE SOUND

Buy From the World's Largest Suppliers

Exceptional Bargains in New, Used and Rebuilt Motion Picture Apparatus. Recent Government Surplus and Liquidation of other manufacturers such as PACENT, ROYAL, AMPLIFONE, POWERS CINEPHONE, TONE-O-GRAPH, HIOPHONE, RCA PHOTOPHONE and others now offered to our trade.

Write for Our Latest Illustrated Catalogues

S. O. S. CORPORATION

Dept. RAC 1800 Broadway, New York, U.S.A.
EXPORT: 120 Liberty St., New York
CABLE ADDRESS: "BOSOUND" New York. All Codes.

CONCOURSE

Dry Electrolytic
Wax Paper

"Peewee" Paper Tubular

CONDENSERS

389-409 WALES AVENUE, NEW YORK
Write for 1934 Catalog

- One Trutest special 4 prong shielded plug-in set of coils wound on 1 1/4 in. forms, L1, L2;
- One Trutest 2 1/2 mhy. R.F. choke, R.F.C.;
- One 200 hy. plate choke, Ch.;
- One type 34 pentode, V1;
- One type 32 screen-grid tube, V2;
- One type 33 pentode V3;
- One rotary switch with bakelite knob, Sw.1;
- One vernier dial;
- One 6 conductor battery cable;
- One roll solid hook-up wire;
- Two screen-grid clips;
- One Trutest 5 prong wafer socket;
- Two Trutest 4 prong wafer sockets;
- One Trutest 4 prong coil socket;
- One phone plug;
- One pair phones;
- Three 45 V. "B" batteries;
- Three 4 1/2 V. "C" batteries;
- Two 1 1/2 V. "A" cells;
- One Trutest metal chassis.

SHORT-WAVE BOOSTER

(Continued from page 735)

Construction

An approximate idea of the layout of the various parts employed may be obtained from Fig. A. The two 78 tubes are completely shielded to insure stability of operation and maximum efficiency. The "can" which contains the coils is removable, and a separate can with coils is provided for each wave band. This unit slides "in" or "out" of the receiver, making contact with spring prongs that are mounted in the space above that allotted for the "can." A view of the coil can construction may be seen in the top photo which illustrates the booster in its entirety.

Only two wires are required for the entire installation—no tampering with your present receiver being necessary. These two connections are the "antenna" and "ground", which connect to this booster instead of to the receiver, as formerly. The set's "antenna" and "ground" posts are connected to two special terminals (marked for this purpose) on the booster. Then plug the power cord into the light socket and after a few seconds that are required for tubes heating up, the unit is ready for operation. It may be necessary to reverse the plug where direct current is being used.

Tuning the Booster

Tuning is accomplished in the same manner as before, excepting that two tuning controls are now in use. The booster control will generally operate in step with the tuning dial of the receiver, i.e., if the booster tuning dial is at 40 then the receiver tuning dial should tune in the vicinity of 40. A separate volume control is included in the design of this unit, and it regulates the degree of sensitivity (or volume) that may be desired. A complete schematic wiring diagram of the Booster is shown in Fig. 1.

LIST OF PARTS

- One dual variable condenser, 140 mmf;
- One Postal drawer coil socket;
- One set Postal drawer coils (14 to 200 meters);
- One Postal front panel, engraved;
- One drilled metal sub-base;
- One crystal finished cabinet with rubber legs;
- One large knob;
- Two small knobs;
- Three 6 prong sockets;
- One 30 hy. filter choke;
- One 12,000 ohm volume control potentiometer and switch;
- One rotary switch;
- One dual 8 mf. electrolytic cond. 200 V.;
- One 0.5-mf. 200 V. bypass condenser;
- Two .1-mf. 200 V. bypass condensers;
- One .001-mf. mica condenser;
- One 7 mhy. R.F. choke;
- One 300 ohm. 1 W. resistor;
- One 290 ohm line resistance cord;
- Two screen-grid caps;
- Five mounting terminals;
- Two shields and bases;
- Two 78 tubes;
- One 25Z5 tube;
- One aerial and ground binding post nut;
- One 2 ft. shielded cable;
- Screws and hardware;
- One aeroplane dial.

WELLWORTH Worthwhile Bargains!

Here are two products of famous companies—the quality of each piece of equipment is only too well known. At prices far below their regular cost, this merchandise can be bought. Order from this advertisement. DO NOT WRITE FOR CATALOG.

G. E. PHONOGRAPH MOTOR

\$3.95

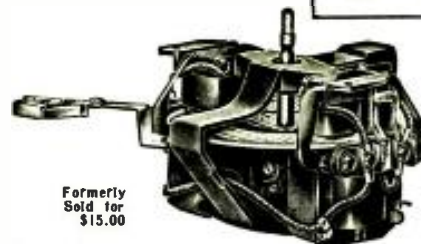

Formerly Sold for \$15.00

VARIABLE speed induction type self-starting, 110 volt, 60 cycle, AC, with lever control. Speed range from 5 to 200 RPM. Can be installed in place of old-fashioned, hand-winding speed motor. Also ideal for display turn table, and a hundred other uses. These G.E. Electric Motors are brand new, in original factory cartons. Same motor that formerly sold for \$15.00, **\$3.95** only

Shipping Weight: 11 lbs.

DEALERS AND MANUFACTURERS WRITE FOR SPECIAL PRICE IN QUANTITY.

WESTINGHOUSE Power Generator

Manufactured by the Westinghouse for U.S. Signal Corps. Ball-Bearing Rotor, case dimensions 1 1/2" x 6 1/2" diam. Guaranteed new and perfect. Shipping weight 13 lbs.



While they last! \$4.95

Here is what one of our customers writes:

"These generators are being used in a small fishing village, where the only current is supplied from a 2 K.W. D.C. generator.

As it was impossible to use A.C. sets and especially my short wave transmitter using two '35 tubes, one of the generators is used to supply my two A.C. receivers and the other to supply power for the transmitter. Both generators are run by a 1/2 horsepower D.C. motor. These generators perform perfectly and have been absolutely trouble free. The voltage and current regulation is remarkably stable, taking a considerable overload."

—WM. BERGG, W 7 BDR, Astoria, Ore.

REMIT BY CHECK OR MONEY ORDER FOR FULL AMOUNT OF EACH ITEM—SHIPPED EXPRESS COLLECT, NO C. O. D. ORDER ACCEPTED—MONEY REFUNDED IF NOT SATISFIED.

Wellworth Trading Company RC-634
111 West Lake Street, Chicago, Ill.

Enclosed you will find my remittance of \$_____ for which please send me:

- () G.E. Phonograph Motor, \$3.95 each
- () Westinghouse Power Generator, \$4.95 each.

Name

Address

City..... State.....

BEGINNER'S ELECTRIC I TUBE SET

(Continued from page 730)

slightly harder than wood, but it has so many advantages as a foundation for radio sets that the extra trouble is more than compensated for in the more efficient operation and mechanical layout that is possible with a metal chassis. Ordinary wood working tools will cut aluminum nicely and common twist drills are used for making small holes. For the larger holes a circle cutter is a great convenience but it is quite possible to drill a series of small holes around the circumference desired, cut out the metal between with a small chisel or sharp knife and smooth the hole with a small, coarse half-round file.

For bending you should equip yourself with a couple of small angle bars, say about 2 x 2 x 12 ins. long which can be clamped in the vice. Place the piece to be bent between them with the "bend line" exactly at the edge and hammer it down flat with quick, light strokes; working back and forth across the width of the piece. Don't try to make the bend too sharp or it will crack; and get the bend in the right place the first time as it will almost invariably crack if you try to straighten it out to rebend.

The correct method to pursue in the building of the set is: first, layout, cut to size and drill all holes; second, bend; third, assemble the two pieces of the chassis by means of nuts and bolts through the holes provided; fourth, mount all apparatus in the positions shown; fifth, wiring. It will be necessary when wiring to drill several small holes which are not shown on the layout to pass wires through the sub-panel but these can best be located and drilled as required. Always smooth the edges of such holes with a countersink or large drill to prevent the burr or sharp edges from cutting through the insulation.

The tuning condenser is mounted on the front panel through the medium of two No. 6-32 bolts. Several small washers or other form of spacer are placed over each screw between the panel and frame of the condenser to hold it parallel to the front panel.

The filament resistor, R5, is mounted upright through a single hole in the sub-panel by means of one of the screws that will be found holding the brackets. A cardboard tube is generally packed around the resistor on which is marked lines indicating one-eighth of the total resistance; if you do not have available a voltmeter to set the filament

voltage across the tube to its proper value it can be arrived at approximately by setting one end sliding contact opposite the first of these marks. This filament resistor becomes quite hot in operation so do not fail to remove the cardboard tube and keep all insulated wires well clear of this resistance.

In mounting the jack for the phone plug be sure that the frame and lock nut are well insulated from the chassis. Otherwise you will have a direct short across the power supply which will probably ruin the rectifier section of the 12A7 tube. Also be sure that the center arm of the potentiometer R4 is not grounded to the chassis or it will be impossible to control oscillation. Some makes of potentiometers, particularly the newer types have the center arm insulated from the shaft and lock nut. If this is not the case it will be necessary to insulate the arm and terminal (the center one) from the panel.

Incidentally, while on this subject of grounds, it might be well to point out that just any old kind of connection to an aluminum chassis does not constitute a satisfactory ground. The surface of this metal readily oxidizes and the oxide is an excellent insulator. The correct way of grounding any circuit is to establish a common ground point at some convenient location and run wires, insulated like any other part of the circuit, from each grounded piece of apparatus to this point, soldering them all together and making a perfect contact to the chassis. Many a case of persistent oscillation has been cured by this simple treatment.

Operation

After the circuit is completely wired, check it over carefully—remember you are not dealing with batteries on your work bench now, but with the entire power of your lighting circuit—for the family would not in the least appreciate being left in the dark because you blew a fuse. You had better locate the fuse for your circuit and have a spare one on hand before you start to work—just in case.

When you are absolutely sure that all wiring is correct, you may insert the line plug and turn on the switch. After a few seconds a bright point of light will be seen inside the cathodes of the tube and they will gradually heat up to a dull red glow. The circuit is then ready to operate. If D.C. is being used, it may be necessary to reverse the plug.

WARNING: The post marked "Grd" on the diagram is not to be connected to a ground unless it is absolutely necessary to do so to secure quiet operation and then only after carefully checking to see that the ground side of the power line is connected to the

(Continued on page 761)

RCP • RCP • RCP • RCP • RCP

Tests Tomorrow's
Tubes TODAY!

"DEPENDABLE"

NEW TUBE
Model 303-A TESTER

\$1875

COMPLETE

List \$35.00

\$1475

KIT FORM

List \$27.50



NET TO DEALERS AND SERVICEMEN ONLY

YOU'LL look far to find the equal of this new RADIO CITY Tube Tester. No need to worry about tomorrow's tube developments. With the 303-A, you are prepared TODAY for all current tube types and up to 50 new ones when they arrive. Unique switching arrangement, spare contacts and panel indications provide for more than 130 different tube types. Accurate D'ARSONVAL type moving coil meter. Only two selector switches to operate. Has short tester with pilot light indicator and molded sockets, including large and small 7-prong. Gas test with meter and second plate test for all rectifiers. Line voltage adjustment switch and many other features you will value. Handsome leatherette carrying case.

NEW Model 403
MULTITESTER



The quality tester, in compact form. Will always be up-to-date. Case measures only 5 3/4" x 8 3/4" x 2 3/4". D'ARSONVAL type moving coil assures accuracy within 2 percent. Triple-range ohmmeter 0-2,000,000 ohms. Four-range voltmeter 0-5-50-250-750 volts. Milliammeter 0-50. MICROAMMETER 0-500 microamperes for measuring small photo-cell and Brill currents. Etched panel. Crystalline finish case. Self-contained batteries. NET \$14.95 to Dealers and Service Men. List \$37.50. Also KIT FORM \$10.95 NET. List \$27.50.

Write Dept. RC-6 for FREE Data Sheets
RADIO CITY PRODUCTS CO.
48 WEST BROADWAY, Dept. RC-6, NEW YORK, N. Y.

RCP • RCP • RCP • RCP • RCP

"C'm up 'n' see me sometime"
If You Can't Come, Write

Don't be satisfied with ordinary reception. When you "tune in" you should know in advance there will be no interference of any kind. You are entitled to complete satisfaction, and you can get it at small cost.

Whether you have a broadcast, short wave, automobile or all-wave receiver, you can get clearer, more realistic, noise-free radio reception by the use of the

LYNCH
NOISE-FREE
ANTENNA SYSTEM

It most outperforms any other kind of aerial or so-called aerial simulator, or it won't cost you a cent.

Write TODAY for Full Details

Satisfaction or Your Money Back

ARTHUR H. LYNCH, Inc. 51 Vesey St. New York, N. Y.

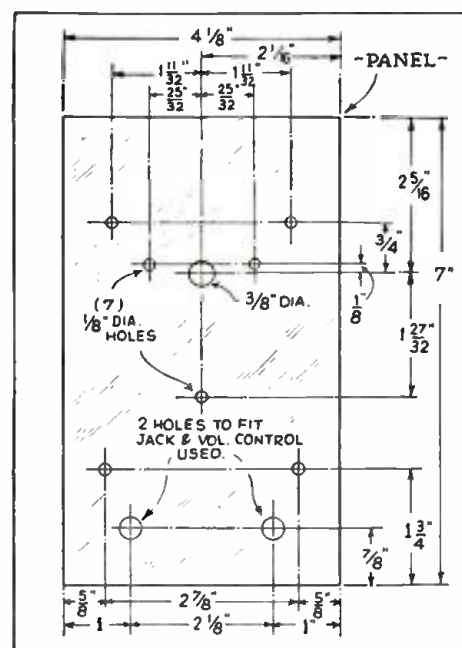
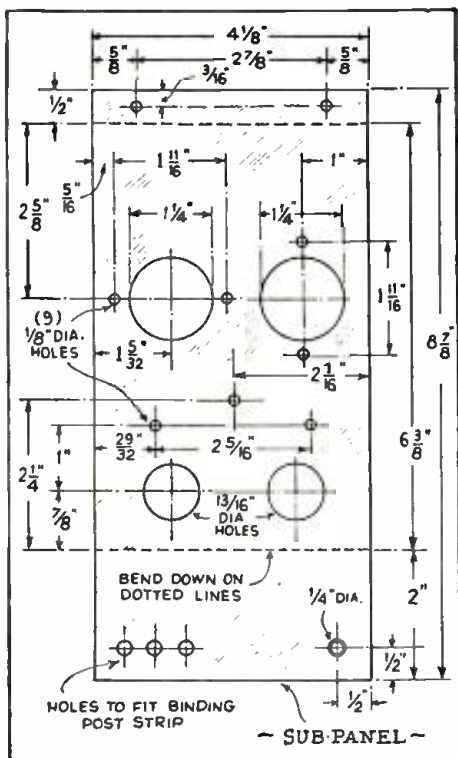

Fig. 2
Layout and drill sizes for the panel.

Fig. 3, left
The sub-panel layout details.

BRINGS A NEW THRILL TO RADIO



The UNI-SHIELDED "3"

Hailed and acclaimed by Short Wave Craft, Popular Mechanics, N. Y. Sun, Short Wave Magazine. What a thrill it will bring you! The greatest, simplified, low priced S.W. set yet developed. Available in 2 or 3 tubes. Sold exclusively by us. Send for the "Success Story" or this amazing receiver from Short Wave Headquarters!

Kit less tubes and coils.....	Two	Three
Wired ready for use, add.....	\$5.75	\$7.45
Set of 3 special coils.....	2.50	2.75
Set of matched tubes.....	1.45	1.45
	1.93	2.90

Big New FREE Catalog

from Short Wave Headquarters. Lists over 10,000 bargains. Big Special S.W. Section. World's Biggest Values . . . always at lowest wholesale prices.

WHOLESALE RADIO SERVICE CO. INC.
100 SIXTH AVE., Dept. C-64 New York, N.Y.

WANTED!

Jobbers--Mail Order Houses and Representatives in all Territories
TWO FAST MOVERS



Free Edge Cone and Voice And—Field Coils for all Coil Assemblies Dynamic Speakers We also Manufacture Various Types of Magnetic Speakers
We can Supply and Remedy Your Speaker Needs. Speaker Mfrs. Since 1921
LEOTONE RADIO CO., 63 Dey St., New York, N.Y.

"PERFECTED" ALL-WAVE SET

12,500 MILES ON ONLY TWO TUBES!

Simple to build—easy to operate—World-Wide reception range—and extremely inexpensive! We have sold thousands of these remarkable short-wave kits, and novices and "old-timers" alike have marveled at the amazing results obtained. These kits contain every necessary part to construct the entire receiver. The coils, which tune from 15 to 200 meters, are wound on polished bakelite forms. The attractive crystal finished metal chassis and panel comes with all holes necessary to mount the apparatus and this, together with our complete, detailed, clear instruction sheets greatly simplifies construction.
DRY CELL OR AC MODEL \$4.75
Two Coils 200 to 625 Meters \$1.25
Deposit required with all orders.
HARRISON RADIO CO.
142 LIBERTY ST., Dept. R-6, NEW YORK CITY

10¢ A DAY BUYS A NEW REMINGTON PORTABLE TYPEWRITER

Special 7-Day Free Trial Offer
Think of it! You can buy a new standard Remington Portable Typewriter for but 10¢ a day. Standard keyboard. Small and capital letters. Beautiful finish. Carrying case included free. Exceptional money-making opportunities. Write today. Say: Please tell me how I can get a new Remington Portable typewriter on your special 7-day free trial offer for but 10¢ a day. Remington Rand Inc., Dept. RC-11, Buffalo, N. Y.



Back Issues of Radio-Craft

which you might need to complete your files, can still be had at the price of 25¢ per copy. Send us your requirements, together with your remittance in check or money order.
RADIO-CRAFT, 96-98 Park Pl., N. Y. C.

RADIO EQUIPPED POLICEMEN

(Continued from page 720)

the patrolman who carried it), and a fixed tuning arrangement so that no dial searching or twisting would be necessary.

The evolution of several experimental models is shown in the chassis illustration, Fig. B.

This receiver uses 3 type 30 tubes, and the circuit employs super-regeneration. Provision is made for semi-fixed tuning—to peak the signal by hand-spread adjustment. The extremely compact construction is clearly shown in this illustration. The chassis measures approximately 2 1/4 x 4 3/4 x 1 3/4 ins. in depth; its weight is approximately 1 3/4 lbs., without tubes or container. The receiver proper is contained in a box which clips to the right side of the officer's Sam Browne-type belt. A special battery box (which may be employed) will clip to the left side of the belt. The construction of the special Sam Browne belt is such that the rear of the shoulder straps are of more than ordinary width in order to accommodate an antenna, which is sewn within it. A single, small, feather-weight headphone is used, and the total weight of both receiver and battery boxes, complete, does not exceed 6 lbs. All connections are made by means of a cable with plug connections.

Reception takes place on a frequency of 20 megacycles (15 meters), since the effects of static, and man-made interference (station transmissions, sparking from commercial electrical appliances, etc.), are almost negligible at this extremely high frequency. Consistent good reception from a 50 W. transmitter can be obtained, in average localities, over a radius of about 10 miles, which is more than suitable for average demands.

It might be expected that those cities which are already equipped with radio patrol cars may not have any need for radio equipment of this type, but, as pointed out at the beginning of this article, where the radio-equipped patrolman serves as an adjunct to the radio-equipped car (and motorcycle), the possibility of apprehending criminals is tremendously increased.

READER'S DEPARTMENT

(Continued from page 737)

munication, it is within the power of the Federal Radio Commission, through their local district representative, to take action. However, the commission is ordinarily too busy with other matters to step into such cases. However, if the seriousness of the case is brought to the attention of the Federal Radio Commission, it is possible that they will act.

A CANADIAN SERVICE MAN'S TEST BENCH

Editor, RADIO-CRAFT:
The enclosed photograph is of the test bench and panel of William's Radio Service and was constructed by the writer.

The bench is 6 ft. long by 31 ins. wide. The panel is 3 ft. long by 2 ft. high. Both are constructed of British Columbia fir, stained and varnished.

The test instruments are of the "reasonably priced" type, some of which have been in constant use for several years.

At present, the writer is engaged in constructing a similar panel using precision instruments of the more expensive type. I trust this will be an interesting photo for your readers to see.

WILLIAM T. RIDD,
3452 Evelyn St.,
Verdun, P. Q., Canada

Thanks, William, for the photo and letter. We are sure that many of our readers who are engaged in servicing work will be interested in seeing what one of their Canadian cousins is doing in the way of fitting up his shop.

Here's a book RADIO MEN refer to many times daily



A Valuable, All-round Radio Book!

HERE is one radio book that answers every conceivable question on interference. It contains 76 pages, 8 1/2 x 11 inches, chock full with wiring diagrams, drawings and photographs—showing where interference originates—how it is distributed, and how to eliminate it. This is a wealth of information needed by every radio listener, dealer and service man.

Send 50 cents in stamps or check for this book.

RADIO-CRAFT MAGAZINE
96-98 PARK PLACE NEW YORK, N. Y.



Many POPULAR EXPERIMENTS in Every Issue!

Over 150 Illustrations
25c the Copy
On All Newsstands

EVERYDAY SCIENCE AND MECHANICS is the finest scientific-technical-mechanical-constructional magazine in the field. Up-to-the-minute with news flashes of scientific events. Dozens of interesting articles and many popular experiments. Ideas from which you can make things to sell.
A HOST OF INTERESTING SCIENTIFIC SUBJECTS COVERED—Aviation—Woodworking—Astronomy—Patents and Inventions—Book Reviews—Metalworking—Chemistry—Engineering—Microscopy—Electrical Experiments—Lath Operation—Shop Hints and other subjects.
SPECIAL OFFER—\$2.00 for One Year—(Canadian and foreign \$2.50). Send check or money order.
EVERYDAY SCIENCE AND MECHANICS
98R Park Place New York, N. Y.



10 HOURS of Reading Pleasure

Five Stirring Stories of Future Science in Current Issue

WONDER STORIES brings to its readers vivid, thrilling, and absorbing tales of adventure on alien planets—stories of biological monstrosities, time-travel, the future civilizations of man, and other educational science-fiction themes.

Here is the contents for June: INTO THE INFINITEST-MAL by Kaye Raymond, THE DOORBELL by David H. Keller, M.D., COSMIC CALAMITY by W. Varick Nevins, III, ADIEPT IN THE VOID by John Pierce, B.S., and PHUSO, a tremendous German novel by Friedrich Freksa, and several interesting departments. Join the SCIENCE FICTION LEAGUE.

SPECIAL OFFER—One Year for \$2.00. Send check or money order.
WONDER STORIES, 98R Park Place, New York, N. Y.

BEGINNER'S 1 TUBE SET

(Continued from page 759)

chassis and not the "hot" side. This can be checked by the simple process of placing a test lamp (a socket and lamp having short leads with bared ends) between the ground post and the proposed ground connection. If the lamp lights remove the line plug, turn it around and reinsert it. Then make the ground connection.

Attach the antenna, and plug in the headphones. Screw the adjusting screw on C1 almost all the way in and turn R4 all the way to the right. Now, on turning the tuning dial from one end to the other a series of squeals should be heard. If this does not occur it indicates that the circuit is not oscillating. Turn back the screw on C1 slightly and try again. Keep trying this until oscillation occurs all over the dial with C1 screwed in as tightly as possible.

The position of C1 will depend greatly on the aerial used, the longer the aerial the looser C1 will probably have to be since a long aerial loads the circuit and keeps it from oscillation. However, a long aerial is necessary for proper pickup and for any DX work. About 75 feet, as high as possible and well insulated would be about right.

Once the proper position for C1 is found it may be left alone and the only controls necessary will be the tuning dial and R4 for feed back. Like any oscillating circuit the most sensitive point will be found just outside the zone of oscillation. Slow, careful tuning and skillful handling of the oscillation will result in some rather remarkable DX records for such a simple set.

Theory

There is nothing remarkably new in any single feature of the set, the novelty results from the combination of features in a single unit. The signal, picked up by the antenna is fed through C1 to the tuned circuit C2-L1 and thence through the grid leak and condenser to the grid of the tube where detection takes place. The audio component of the signal is fed from the plate to the tube through the headphones while the radio frequency component of the signal is blocked by the choke L3 and forced to travel through L2-R4 and back to ground through C4. The strength of the radio frequency current in this circuit, and hence the amount of feed back is governed by the resistor R4.

Power is supplied to the plate of the tube through the rectifier portion of the tube which gives rise to a pulsating D.C. This is filtered into a pure D.C. by the network L4-C6-C7. No condenser is put on the rectifier side of the inductance L4 for two reasons. First, a high value of D.C. voltage is not desirable for grid leak detection; and a condenser input would raise this value considerably. Second, a choke, input, as used, tends to lessen the difference between the plate voltage as between an A.C. and a D.C. line current.

The resistor R5 serves to drop the line voltage of 120 to the 12.6 required by the filament of the tube. This had better be adjusted by means of a voltmeter to the proper value if possible.

Troubles

No OSCILLATION:

Reverse connections to L2.
Be sure condenser C4 is non-inductive type.
Be sure choke L3 is effective.
Raise screen-grid voltage by decreasing value of R3.

As a last resort increase turns of L2.
Be sure R4 is connected in the right direction; so that when the line switch is off the resistance is all in.

UNCONTROLLABLE OSCILLATION:

Decrease screen voltage by increasing value of R3.

Decrease value of C4.
Remove choke L3, if this completely stops oscillation decrease value of C5.

Check circuit for unwanted sources of feedback.

As a last resort decrease turns on L2.

DRONE HOWL OR "PIOP":

This is controlled largely by the value of R2; the smaller this value the more smoothly oscillation occurs down to the point where control through R4 is lost.

(Continued on page 763)

HEADQUARTERS FOR PUBLIC ADDRESS AMPLIFIERS

BUY DIRECT FROM MANUFACTURER AND SAVE BIG MONEY!



Here Are Our Most Recent Portable Public Address Amplifier Developments:

Self-Contained Electric Phonograph "MIKE-PHONO-RADIO" COMPLETE PORTABLE P. A. SYSTEMS

Available in Choice of Three Basic Models:
110-VOLT A.C. 7 1/2 WATT 2 STAGE 2A5 CLASS "A" MODEL—110 VOLT A.C. 12 WATT 3 STAGE 2A3 CLASS "A" MODEL—6 VOLT STORAGE BATTERY OPERATED 13 WATT 3 STAGE 79 CLASS "B" MODEL — WHICH MAY BE OPERATED AT WILL FROM BOTH 6 VOLTS D.C. AND 110 VOLTS A.C.!

All models are equipped with a self-contained "INPUT-MIXER-FADER" CONTROL SYSTEM. Completely housed in a compact (15 3/4 x 14 1/4 x 13 1/2") two section (removable speaker) wood framed, fibre lined case.

Write for our unbelievable low price on this equipment!



JUST-OFF-THE-PRESS!

SEND FOR THIS FREE Radio and Amplifier CATALOG

Entirely New From Cover to Cover

100 PAGES OF BIG MONEY SAVING VALUES

You Can Not Possibly Afford to Be Without This Really Valuable Book — Send For Your Copy Today. WE ARE HEADQUARTERS FOR P. A. SYSTEMS. Buy direct from the manufacturer and Pay Only One Profit!

OFFICIAL PUBLIC ADDRESS AMPLIFIER MANUAL AND SOUND SYSTEM TREATISE

THE ONLY BOOK AVAILABLE OF ITS KIND!



Devoted Exclusively to the Problems Involved in Purchasing, Designing, Measuring, Testing, Installing, Operating, Trouble Shooting, Maintaining, and Money Making Possibilities of Public Address Systems.

AVAILABLE with a VALUABLE SUPPLEMENT SERVICE
100 LOOSE LEAF contains 64 Pages, 8 X 10 OVER 150 DIAGRAMS CHARTS and ILLUSTRATIONS
WRITTEN IN PLAIN CLEARLY UNDERSTANDABLE LANGUAGE

A Vital Necessity to Everyone Connected in Any Way With Sound-Systems—Public Address Work—or Amplifiers and Associated Equipment! Complete and Authoritative!

COAST-TO-COAST-RADIO-CORP.

123 K-WEST 17TH STREET, NEW YORK, N.Y.



U. S. E.

amplifiers and complete public address systems in distributors stocks everywhere.

The U.S.E. distributor in your territory will be glad to demonstrate any type of public address unit that you are interested in. He can give you prompt delivery on your orders and sales help in selling your customers.

With business conditions improving and political campaigns coming on, this year's public address season will be a big one.

Don't overlook the PA profits in your territory. Write for literature and further details.

UNITED SOUND ENGINEERING COMPANY

Manufacturers of Specialized Sound Equipment

2233 UNIVERSITY AVENUE

ST. PAUL, MINNESOTA

SERVICEMEN!
THE MOST COMPLETE LINE OF CONDENSERS AND RESISTORS FOR EVERY RADIO USE
Write for our new 20-page Catalog folder free of charge

76 Washington Street Brooklyn, N. Y.

Gould Short Wave Radio
INTRA-CONTINENTAL 15-250 ONE-TUBE SET
Complete kit of parts (no drilling)—panel, base-board, variable condenser, antenna condenser, sockets, resistors, condensers, wire, hardware, etc. \$ 9.95 OR DIAGRAMS & IN-CLUDES HEADPHONE TUBE & FOUR PLUG-IN COILS

1-TUBE FOUNDATION KIT
consists of Variable Condenser, base socket, 2 Plug in coils, resistors, condensers, tuning eye control, rheostat, etc. \$1.95

GOULD RADIO & TELE. CO. 170 WASHINGTON ST. NEW YORK CITY

Service Men's Essentials for All Members of the

ORSMA



No. 14—50c each
(Plus 10c for Postage)

No. 3—60c per pad of 50
\$3.00 per ten pads, each of 50



No. 5—50c each

Mail This Coupon Today!

Application for ORSMA Membership in

Executive Secretary, ORSMA
98 Park Place, New York, N. Y.

Kindly send an application blank for
 Full Membership
 Associate Membership

Name

Street or Box.....

City State

RC-631

SERVICE MEN'S ESSENTIALS

THE OFFICIAL RADIO SERVICE MEN'S ASSOCIATION has made arrangements to supply a number of "Service Men's essentials" for the use of its members and associate members. Only members and associate members can buy these items; they are not sold to others.

These essentials are priced at cost, plus a small additional fee which is the only source of income that the Association has. No one obtains any profit or benefit, except the Association itself. Whatever profit accrues, is reinvested for the furtherance and enlargement of the Association.

By using the letterheads, billheads, etc., you present the business-like appearance to your customers, so essential to successful servicing. In addition, the Association has made arrangements with most of the prominent manufacturers to allow special discounts to members, providing ORSMA letterheads are used when ordering.

No. 1 ORSMA LETTERHEADS

These letterheads, shown on the right, are furnished with your name, address and telephone number, printed on excellent paper. They are sold in lots of 100 or multiples thereof, with a distinct saving for single orders of 1,000 or more. You would have to pay many times more if you ordered small lots from your local printer. Per 100, 60c; per 1000, \$3.00.

No. 2 ORSMA ENVELOPES

These are furnished to match the letterheads, printed with your name and address and seal of the Association. They go hand-in-hand with the letterheads and are usually ordered in the same quantity. Per 100, 60c; per 1000, \$3.00.

No. 3 ORSMA SERVICE RECORD CARDS

They serve a double purpose; whenever you complete a job you fill out the report-bill and hand it to the customer; this is the "psychological moment" to collect. By the use of carbon paper a permanent record is kept which is a valuable asset to your business. They are furnished with your name, address and telephone number. Per pad of 50, 60c; per 10 pads, each of 50, \$3.00.

No. 4 ORSMA INSPECTION LABELS

The label is to be filled in with the proper dates, and pasted inside the set or cabinet where the customer will see it. It is a continuous reminder to him that, when service is needed, he can call you again. The advantage is apparent. Per 100, 50c; per 1000, \$3.00.

No. 5 ORSMA LAPEL BUTTON

At the suggestion of many members a handsome lapel button bearing the name and emblem of the Association has been designed. It signifies to your fellow members that you belong to the same Association;—and in addition it gives your customers a better appreciation of the professional nature of your work. 50c each.

No. 6 ORSMA BUSINESS CARDS

These are furnished on a fine grade of paper in two colors with a blotter back. Thus they present an added incentive to your customers to keep them in a prominent place, where they will do the most good. They are printed with your name, address and telephone and bear the official seal of the Association. Per 100, 75c; per 1000, \$4.00.

No. 9 & 10 ORSMA EMBLEM CUTS

These cuts for printing, advertising, etc., are furnished in two styles and sizes. They may be used for newspaper or telephone-book advertisements or for printing of any kind. Large size, 1 1/2 x 1 1/2 in., \$1.35 each; small size, 3/4 x 3/4 in., \$1.20 each.

No. 11 ORSMA MEMBERSHIP SIGN

A set of three of these signs, printed on heavy cards, and having holes punched in order to hang in your office or store, and are sold to members and associate members. They are large enough so that they are quite prominent and the two tone effect makes a very attractive appearance. Set of three, 50c.

No. 12 ORSMA ADVERTISING DISPLAY SIGN

A two color sign printed in large letters with your name, address and telephone, with the seal of the Association. This sign is sold in quantities of 25 or more and is ideal for hanging in stores, offices, etc., for advertising purposes. Set of 25 cards, \$3.00.

No. 13 RADIO SERVICE MEN'S ASSORTMENT PACKAGE

This includes one gold filled lapel button, 100 letterheads, 100 envelopes, 50 service record cards, and 100 labels printed with your name and address as described above. The whole assortment costs only—\$3.00—a worth-while saving. Complete, \$3.00.

No. 14 ORSMA MEMBER CERTIFICATE

A handsome diploma-like certificate engraved on stiff vellum-bond. The certificate is personally signed by the President and Executive Secretary and the corporation stamp of the Association is impressed on a red seal attached to it. Your name, certificate number and date of registration are lettered by hand and the Certificate is mailed in a cardboard tube to insure safe delivery. Each 50c, plus 10c for postage.

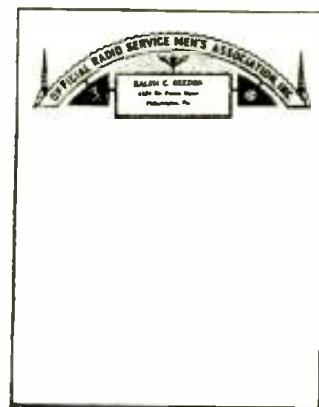

No. 1—60c per 100
\$3.00 per 1000

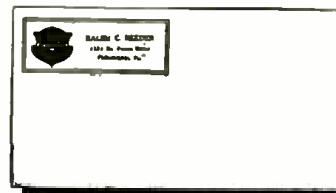

No. 2—60c per 100
\$3.00 per 1000



No. 6—75c per 100
\$1.00 per 1000



No. 4—50c per 100
\$3.00 per 1000

OFFICIAL RADIO SERVICE MEN'S ASSOCIATION

RC-631

98RC Park Place, New York, N. Y.

Please send me the following RADIO SERVICE MEN'S ESSENTIALS which I have selected from this advertisement. My remittance for \$..... is enclosed. Send remittance in form of check or money order. Register letter if it contains cash, currency or unused U. S. Postage Stamps.

.....

.....

Name ORSMA No.

Address City and State

The voltage on the screen-grid is rather critical in this circuit. If it is too low the circuit will not oscillate and will be less sensitive generally. If it is too high it may cause an annoying 60 cycle hum in the phones. The trick is to get it as high as possible without allowing this hum to occur or causing uncontrollable oscillation. This voltage is governed by the network R2, R3, and considerable experimentation with these two values will probably be rewarded with greatly increased sensitivity and better all-around performance.

List of Parts

- One midget tuning condenser, 350 mmf., C2;
- One Hammarlund trimmer condenser, 5-70 mmf., C1;
- One pig-tail mica condenser, 350 mmf., C3;
- One pig-tail mica condenser, .001-mmf., C5;
- One Concourse non-inductive paper condenser, .1-mf., C4;
- Two Concourse type V8 electrolytic condensers, 8 mf., C6, C7;
- One Centralab "ELC" potentiometer with line switch attached, 25,000 ohms, R4;
- One carbon resistor, 1/2-W., .3-meg., R2;
- One carbon resistor, 1/2-W., .5-meg., R3;
- One carbon resistor, 1/2-W., 3 megs., R1;
- One Electro-wire-wound resistor, 400 ohms, 50 W., R5;
- One R.F. coil, screen-grid interstage, shielded, L1, L2;
- One .85 mhy. R.F. choke coil, R.F.C.;
- One midget filter choke, 20 hy., center tapped, L4;
- One single-circuit jack and insulating bushing, J;
- One small 7 prong wafer socket;
- One type 12A7 tube;
- One binding post strip marked "Ant.-Grd.";
- Aluminum for panels, 1/16-in. thick, wire, small hardware, line plug, etc.

When removing the 4 prong sockets, if a hot soldering iron is applied to the nuts the screws can be backed out easily; the voltage divider should be mounted on a pair of spacing pillars to facilitate connecting the field leads.

We are using a pair of Jensen D-9 speakers with the rig set up as shown schematically in Fig. 7 and, by picture diagram, in Fig. 8, and plenty of volume is obtained. If it is desired to operate the amplifier with a single speaker, one having a push-pull output transformer will be required, and an extra 2,500 ohm resistor to connect between the unused field terminals.

In addition to the savings in the cost of new tubes, when the 47s replace the 10s, it must be remembered that a lower voltage for the plates is required and the amplification is increased enormously.

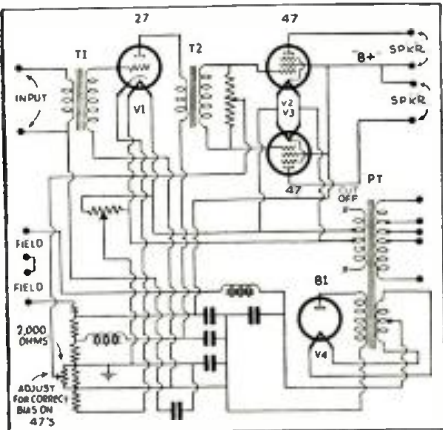

Fig. 7
The amplifier using the type 47 tubes.

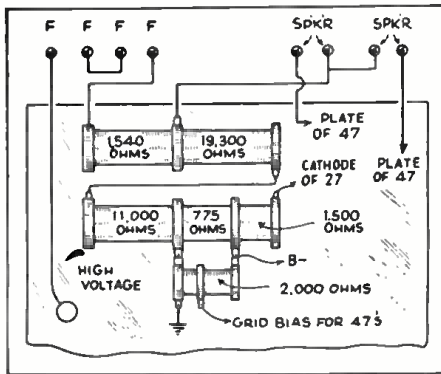

Fig. 8
The arrangement of resistors for the 47s.

SHORT CUTS

(Continued from page 733)

placed in the transmitter (W9CLM) and sacrificed to the great god "DX."

As a pair of 10's required the outlay of more mazzuma than we have even seen for some time—our local banks all took the vacation cure—consideration was given to the possibility of utilizing less expensive tubes.

After careful consideration of the various factors involved, and quite a bit of haywire experimentation to determine the relative desirability of the different tubes available, it was decided to adapt the amplifier to use the type 47 pentodes as replacements.

The circuit as revamped for these tubes is shown in Fig. 7. The following new materials are required:

- Two 5 prong sockets; two type 47 tubes;
- one 2,000 ohm, 25 W. resistor; one 15 ohm, center-tapped resistor; four binding posts marked FIELD; four binding posts marked SPEAKER; one bakelite strip, 1 x 1 3/4 x 3/16-in. thick.

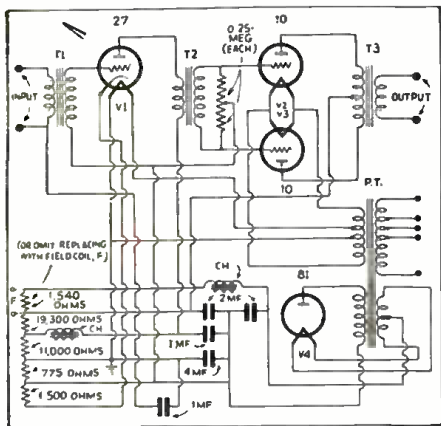

Fig. 6
The amplifier before the changes were made.

An unusual tube tester appears at the right. Precision laboratory-type meters are used throughout, to increase the unit's accuracy.

NEW TUBE TESTER

THIS expensive instrument is essentially a laboratory unit, designed to test all new tubes. Adaptable at a portable or stationary type. It incorporates the following features: ability to measure with high precision all existing tubes; automatic relays protect all current meters; automatic relays change all voltmeter ranges; extremely wide range; simplicity and convenience of operation.

Relays automatically shift the various meters to the correct range scale. Pilot lamps interlocked with the relays serve to indicate the meter and scale in use; the tube-test ranges include: current range, 0 to 15,000 ma.; mutual conductance, 1 to 25,000 mhos.; amplification factor, 0.1- to 5,000; impedance, 100 ohms to 50 megs.



Just the thing / for the Summer!

a **PORTABLE**
Universal A. C.-D. C.
Short Wave Receiver



Designed by
Herman Cosman

THE high ratio vernier dial permits adjustment of tuning condenser. Smooth regeneration. Four IBCNO plug-in coils, are furnished covering wave lengths from 15 to 200 meters. A broadcast coil (200-550 meters) makes the Universal Portable an ALL-WAVE receiver. No dead spots on the coils. Waterproof, fabricoid covered carrying case, 13" x 9 1/2" x 6 1/4". Strong leather handle. Ample room for tubes, coils and shield when cover is closed. Enjoy the thrill of short wave stations and regular broadcast programs anywhere you go where 110 volt electric current is available. **\$9.95** Kit of parts including beautiful case. \$2.00 Wired and tested, extra. \$2.00 Set of RCA licensed tubes (1-73, 1-43, 1-253) \$3.25 Broadcast coil \$.79

TRY-NO RADIO
85 Cortlandt St., Dept. C6, New York, N. Y.

RADIO for 1934

NO SERVICEMAN DEALER OR SET BUILDER CAN AFFORD TO BE WITHOUT THIS BOOK

Send for the new Spring Edition of Radio's most valuable Catalog. Packed with incomparable quality radio equipment at PRICES THAT ARE CONSISTENTLY LOWER. Lists the most complete line of radio replacement parts for all service requirements. Features new complete Transmitting and Short Wave listings, latest type Set-building Kits, Test Instruments, Sound Systems, and radio's most complete and profitable line of new Receivers.



FREE

ALLIED RADIO CORP.

Dept. D, 833 W. Jackson Blvd. Chicago, Illinois. Please send me FREE your New 1934 Radio Book.

Name _____
Address _____
City _____ State _____

Allied Radio

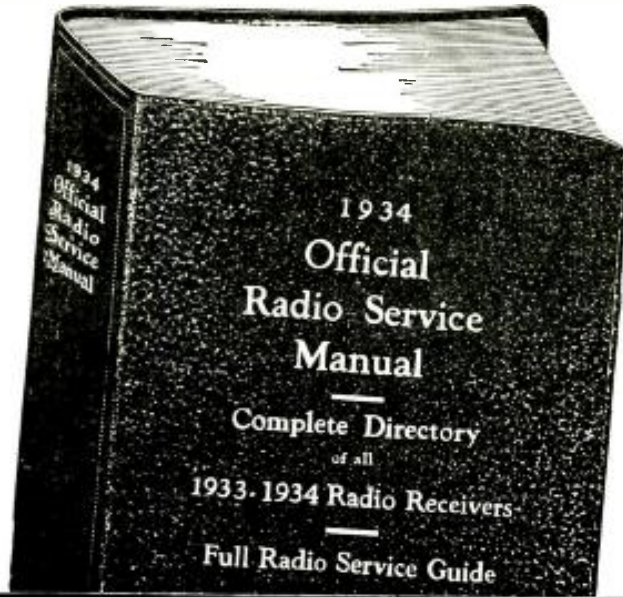

\$3.50

Reg. List Price

400 Pages
Over 2,000 Illustrations
9 x 12 Inches
Flexible, Looseleaf
Leatherette Cover

There's plenty of Servicing Material
in the NEW 1934 Manual

THE necessity of GERNSBACK Manuals in the radio field has been shown by the fact that the total sales of the first three OFFICIAL RADIO SERVICE MANUALS, including the new CONSOLIDATED EDITION, now exceed 80,000 copies.

In preparing this new edition many of the outstanding problems of the Service Men have been considered—methods of servicing, the new equipment constantly needed to cope with new tubes and sets, and the other fields of radio, such as public-address systems, short waves, auto radio and others.

The illustrations in the 1934 Manual are more explicit than before; inasmuch as the diagrams are not limited to the schematic circuit, but other illustrations show the parts layout, positions of trimmers, neutralizers, etc.

As in previous years, the 1934 Manual also includes a FREE QUESTION AND ANSWER SERVICE. In each book will be found 25 coupons, which entitle you to free consultation on any radio service topic.

It is quite evident that the 1934 Edition of the OFFICIAL RADIO SERVICE MANUAL is a decided improvement over previous volumes.

ORDER YOUR COPIES NOW

It is important to every Radio Service Man and Dealer to get his copy of the 1934 OFFICIAL RADIO SERVICE MANUAL now. The new book will prove itself to be invaluable as those volumes of previous years.

No need to delay sending us your order—the 1934 MANUAL, like its predecessors, is a necessity in your business. We strongly advise you to order your copy today.

GERNSBACK PUBLICATIONS, INC.
96-98 Park Place New York, N. Y.

Contents of the 1934 Manual in Brief

- Diagrams and service notes, more complete than ever before in any MANUAL. Not merely the schematic hook-ups will be found, but chassis drawings showing parts layouts, positions of trimmers, neutralizers, etc.
Voltage readings for practically all sets, as an aid in checking tubes and wiring.
All values of intermediate-frequency transformers used in superheterodynes, with the manufacturers' own suggestions as to correct balancing.
Detailed trouble-shooting suggestions and procedure as outlined by the manufacturers' own engineers—in other words, authentic "dope" right from headquarters.
Values of all parts indicated directly on all diagrams.
Section for reference to A.C.-D.C. cigarbox midgets.
Section for reference to public-address amplifiers.
Section for reference to short-wave receivers.
Section for reference to remote-control systems.
A complete compilation of radio tube data, covering both the old and the many new types.
Section devoted to test equipment, analyzers, etc., with full diagrams and other valuable information.
A complete list of American broadcast stations with their frequencies in kilocycles; extremely useful in calibrating and checking test oscillators and in calibrating receivers.
Free Question and Answer Service, the same as in our last two Manuals.
No theory; only service information in quickly accessible form.
Absolutely no duplication of any diagrams; nothing that appeared in any of the previous Manuals will appear in the 1934 MANUAL. This we unconditionally guarantee.
A handy, easily-consulted master index making it easy for you to find almost anything pertaining to your service problem instantly. This index includes all the diagrams published in all the previous GERNSBACK Manuals, as well as the 1931 diagrams. A big convenience and time saver!

Clip—Mail This Coupon Today

GERNSBACK PUBLICATIONS, Inc.
96-98 Park Place, New York, N. Y.
Gentlemen: Enclosed you will find my remittance of \$3.50 for which you are to send me, Postage Prepaid, One Copy of the 1934 OFFICIAL RADIO SERVICE MANUAL. [Send remittance by check or money order; or register letter if it contains cash, currency or unused U. S. Postage stamps.]
Name
Address
City State
RC-634

11 TUBE SUPER BROAD-CAST SET

(Continued from page 734)

tainable, and it can be assembled, wired and balanced by any constructor or Service Man who is familiar with the ordinary superheterodyne and who understands the use of test-oscillator and output meter aligning methods. Its construction should not be attempted by anyone who has never built a radio set before.

In order to anticipate inquiries, a short explanation of the theory involved is given here, insofar as it differs from that of the usual superheterodyne. This should be read and understood before attempting its construction.

Refer to the schematic wiring diagram. The first tube is a 58 R.F. amplifier, tuned to signal frequency by the front section of the three gang condenser. The antenna input system for this tube has been designed for a flat gain over the band with little difference in trimming adjustment for antennas of greatly different characteristics. This tube feeds the second, a 58 first detector, through the R.F. transformer. The oscillator, a 56, is tuned to 175 kc. higher frequency than the signal frequency, by the special section, the rear, of the three gang condenser. Its output is coupled to the detector input through the series cathode coupling coil. The intermediate frequency, 175 kc. is amplified by the 58 R.F. amplifier tube and couples into the second detector, a 55, operating as a full-wave rectifier. In order to avoid trouble due to intra-tube capacity, the grid and plate of the 55 are not used and are therefore grounded. The input to the 55 is center-tapped, the 175 kc. component is filtered out by the R.F. choke and bypass condensers and the A.F. and D.C. voltages appear across 50,000 ohms. The D.C. operates the automatic volume control and the suppressor tube, and the A.F. actuates the grid of the A.F. amplifier tube, the magnitude of excitation being controlled through a volume control potentiometer. The noise suppressor tube, a 57, acts as a relay to block the first A.F. tube, in varying, adjustable degree, when no carrier is being received. This makes the set silent, if desired, between stations, so that no noise of static or man-made interference need ever be heard. This is accomplished in the following manner.

Consider the case of no carrier, that is, the set is tuned between two stations. There will be no D.C. across the 50,000 ohm unit; grid of the noise suppressor will be at practically ground potential. Plate current will flow, causing a drop across a .5-meg. resistor connected in the plate circuit of the noise suppressor tube, which pushes the suppressor grid in the first A.F. tube negative, which in turn blocks the tube so no plate current appears regardless of any voltage which may be applied on its grid from static, etc. Now when a carrier is received, the noise suppressor grid goes negative, plate current stops and the suppressor grid of the A.F. tubes assumes its cathode potential and the tube operates in normal manner as an amplifier. The control, for the degree of noise suppression desired, is provided by the potentiometer, which controls the screen-grid voltage on the noise suppressor tube. This control is adjustable from the rear of the chassis (since once set, it seldom needs changing). When it is rotated fully clockwise, the screen-grid is at zero and the suppressor tube is inoperative and may, in fact, be removed from the set without effect. Since at some intermediate position, the screen-grid may be set at any potential desired, thus controlling the strength of the carrier necessary to trigger the A.F. into operation. Thus, in a very noisy location, say a dealer's store, the control may be set so only very loud locals may be heard, the set being dead silent between stations. Conversely, the control may be set so that a very weak carrier will trigger the set into operation. Any intermediate degree of necessary carrier strength may be set for. This control when set at its critical position, for the weakest carrier, in no way decreases the sensitivity of the receiver, so that for ordinary home operation, it may be adjusted to this position and then forgotten, until a different location or different antenna is used,

or a different degree of suppression is desired.

The A.F. tube feeds a pair of push-pull, resistance coupled, 2A5's. In order to operate true push-pull by resistance coupling, some method of phase-reversing is necessary. The phase-reverser tube, a 58 operating as a triode accomplishes this result. The grid is biased negatively so that the amplification is only one to one, but a 180 degree phase shift results, providing a voltage of correct magnitude and phase to the grid of the lower 2A5. A slight hum unbalance is thus introduced, which is corrected by the 0.2-meg. resistor connected to the plate of V8.

The two .05-mf. condensers in the A.C. line reduce line noises. The rectifier is a 5Z3, having greater capacity than an 80. This filter system is choke-input, making for long life in the rectifier tube. Unusually high filter capacities are used in the power supply, across the field of the speaker, which acts as the second choke. The resultant hum level is quite low, it being necessary to put the ear right at the speaker in order to detect it. It is too low to be measured with conventional instruments.

Unless the builder is quite experienced, it is advisable to very carefully check all circuits before connecting up the set. This can be done with a continuity meter and the diagram and may save trouble later.

Some sort of temporary indicator should be provided in order to align the set, but a permanent shadow indicator can be provided by soldering a short piece of thin, stiff wire to the dial support bracket. If the dial celluloid catches the mounting screw at the extreme ends of travel, clip or round off the corners so that it will ride up easily. The tuning meter should be mounted and carefully centered, directly over the dial light so that its scale will be illuminated also. By slightly shifting its position or the position of the dial light, the pointer shadow can be made vertical over the entire scale.

Put all tubes in their proper sockets, connect up the speaker and an antenna and ground, and turn on the set. The tuning meter should slowly travel to the extreme right as the tubes heat up. If it jams over hard as soon as the switch is turned on, there is a short which must be found. Even before the aligning, some signals should be heard and be tunable if the set is operating correctly. Turn the suppressor control clockwise to the stop and leave it there until all other adjustments are made.

The Suppressor Control

The suppressor control may be adjusted by tuning the receiver to the low-frequency end of the dial, with an antenna on, and to a dial position at which no station is being received. With the volume control well on, a good deal of static and other noises will be heard because the receiver is quite sensitive and the automatic volume control is not operating (with no carrier). Now slowly rotate the suppressor control counter-clockwise until the noise just ceases. The adjustment is not critical. Now when a carrier is tuned in the set will trigger into operation and work in a normal manner, but no in-between-station noise will be heard. For an extremely noisy location, the suppressor control may be adjusted to a position of less sensitivity so that only the louder stations, which are so strong as to over-ride the noise, will trigger the set. Any intermediate position can be used so that during a session of heavy static or during a thunderstorm, the receiver can still be operated on strong stations, with no off-channel noise. Normally, in the usual resident locations, the control should be set at its critical position and when in this adjustment, in no way lowers the sensitivity of the receiver.

When used in the United States, a station can be heard on every channel of the broadcast band, at night. Cross continent reception is not difficult (twenty-five Pacific Coast stations and four Mexicans were heard in Chicago the first night the first model was tested). The selectivity is sufficient so that distant stations can easily be tuned in on the next channel, from a powerful local station. Some slight side-band cutting is compensated by a rising characteristic in the audio and speaker design, and the excellent fidelity obtained can be controlled in the usual manner with the tone control. About 4 watts of undistorted output is obtained at the speaker.



Servicemen!

Reduce the High Cost of Keeping Up-to-Date

Here in one inexpensive 23-lesson course—the only one prepared exclusively for active servicemen—Sprayberry gives ALL the dope on modern radio servicing. Covers every detail including Testing, Repairing (AVC, all wave, short wave, auto radio, P.A., etc.); Parts Testing and Trouble Shooting—also tubes, modernizing set analyzers and selling. No "fluff," mathematics or fancy bindings—a practical, how-to-do-it course that will save hours of reading in scattered sources. Moderate cost—\$10 for course only or \$15 with personal instruction and answers to questions by Mr. Sprayberry himself. Money back guarantee. Write for FREE details!

F. L. SPRAYBERRY 132 Bryant St., N.W. Washington, D. C.
Please rush complete details of your new 28-lesson course, "PRACTICAL MECHANICS OF RADIO SERVICE." These, of course, are free.

Name
Address
City..... State..... C-6/4

Try this FORMULA

WHEN you design or build that New Set Analyzer, Decade Box, Bridge, Ohmmeter or High Resistance Voltmeter why not try this FORMULA:
 $Q+A+MD = PwWR$

When Q equals QUALITY and A equals ACCURACY MD equals MODERN DESIGN and LC equals LOW COST and LAST COST then PwWR is always PRECISION WIRE WOUND RESISTORS.
RESISTANCE RANGE: .25 Ohm to 1 Megohm

TYPE "F"	TYPE "D"
Normal Rating 1 Watt	Normal Rating 1/2 Watt
Maximum Length 1"	Maximum Length 3/4"
Maximum Diameter 5/8"	Maximum Diameter 5/8"
Length of Leads 1 1/2"	Length of Leads 1 1/2"
Furnished with No. 18 Tinned Copper Leads.	Furnished with No. 18 Tinned Copper Leads.



Free Booklets and Price List
Precision Custom Built Wire Wound Resistors, Mfg. by
PRECISION RESISTOR CO.
334 Badger Ave. Newark, N. J.

Use Better Radio Parts

For more efficient short-wave receivers and transmitters use the world-famous Hammarlund Condensers, Coils, Chokes, Sockets and Shields. Backed by 33 years of engineering leadership.

Write for new FREE CATALOG "RC-6"

HAMMARLUND MFG. CO.
424-438 West 33rd Street
NEW YORK CITY

For Better Radio
Hammarlund
PRECISION PRODUCTS

FOR FIXIT SHOPS—ALL FREE

Service Courses in Vacuum Cleaner and Washing Machine Repairing. Thousands of parts for both new and old machines at sensational saving. You can easily increase your income at no extra cost. Hundreds of shops are being benefited by our System.

FREE PROFIT GUIDE TELLS ALL.
URON INDUSTRIES, INC.
Originators and World's Largest Source of its Sort
1251 W. Sixth Street Cleveland, Ohio

● Index to Advertisers ●

A	
Ace Radio Labs.....	752
Aerovox Corporation.....	761
Alden Mfg. Co.....	739
Allied Radio Corp.....	763
Autonaut Laboratories, Inc.....	758
Autopower, Inc.....	748
B	
The Breakers.....	756
Bud Speaker Company.....	756
C	
Central Radio Laboratories.....	748
Clarostrat Mfg. Co.....	746
Classified Section.....	756
Coast-to-Coast Radio Corp.....	761
Concourse Electric Co.....	758
Coyne Electrical School.....	765
Continental Carbon, Inc.....	756
D	
Deutschmann Corp., Tube.....	746
E	
Electrad, Inc.....	754
F	
Fordson Radio Mfg. Co.....	757
G	
General Transformer Corp.....	745
Gould Radio & Television Co.....	761
Grempark Company.....	767
H	
Hammalund Mfg. Company.....	765
Harrison Radio Mfg. Co.....	760
Hygrade-Sylvania Corp.....	749
I	
Insuline Corporation of America.....	748
L	
L & L Electric Company.....	750
Leotone Radio Company.....	760
Lynch, Inc., Arthur H.....	759
Mc	
McGraw-Hill Book Company.....	750
M	
Midwest Radio Corp.....	742
N	
National Radio Institute.....	707
National Union Radio Corp.....	753
O	
Onan & Sons, D. W.....	758
P	
Polymet Mfg. Company.....	758
Popular Book Corp.....	752
Postal Radio Corp.....	754
Precision Resistor Company.....	765
R	
Radio & Amplifier Labs.....	744
Radio City Products Co.....	759
Radio Trading Company.....	768
Radio Trading Association.....	Back Cover
Radolek Company.....	756
RCA Institutes, Inc.....	750
RCA Radiotron, Inc.....	741
Readrite Meter Works.....	751
Romington Rand, Inc.....	760
S	
S. O. S. Corp.....	758
Servicemen's Pub. Co.....	744
Sexology Magazine.....	756
Shalleross Mfg. Company.....	752
Shure Brothers Company.....	754
Silver, Inc., McMurdo.....	747
Solar Mfg. Company.....	754
Sprayberry, F. K.....	765
Supreme Instruments Corp.....	743
T	
Traplett Elec. Instrument Co.....	755
Try Mo Radio Co., Inc.....	763
U	
United Sound Engineering Co.....	761
Uron Industries, Inc.....	765
W	
Webster Company.....	753
Wellworth Trading Company.....	758
Wholesale Radio Service Co.....	760

(While every precaution is taken to insure accuracy, we cannot guarantee against the possibility of an occasional change or omission in the preparation of this index.)

OPERATING NOTES

(Continued from page 755)

GLORITONE MODEL 26

OPEN speaker field coils often present one of the most difficult problems in service work when the Service Man is situated, as I am, in a part of the country where replacement parts are not quickly obtainable. Last week, however, I made a discovery that I know will prove a time-saver to everyone who has to do with the Gloritone model 26 midget receiver.

This set has an 11,000 ohm field tapped at 2,640 ohms and wound with very small wire. I got a good many of these machines to repair and the majority of them have this coil open, but this time I got three of them in the same day, with this same defect! Naturally, the first point at which to expect trouble in a coil of this type would be the joints where the heavy wire output leads are connected to the fine wire of the coil. However, examination of a number of defunct coils before had proven this rarely to be the case. Since the wire was very small the thought occurred that it might be possible to burn through the break, and this was quickly and easily done though it required a 200 V. supply to break through the gap.

A word about removing the coil might not be amiss. In this particular set, the speaker, a Utah, is assembled, not with bolts or screws but is cemented together in a way to make re-assembly difficult. However, the field coil can be easily removed and replaced by carefully observing the following procedure.

Remove the cone-centering screw, then carefully pry the cone-centering spider loose from the cone, excepting at the point where it is riveted. Hold the speaker in a vise and loosen the jam nut that holds the center pole in place. A few quick blows with a hammer and chisel are usually the best way of doing this. The pole piece can then be pushed straight through the center of the cone by holding the spider to one side. Re-assembly is very simple if this method is followed. The spider is then cemented into place with a bit of film cement or nail polish, the cone centered and the job neatly completed.

DON BLAIR

MISCELLANEOUS FAULTS

IF the customer complains of the ground wire sparking on the water pipe, don't be alarmed. It is most likely the buffer condensers across the line. A number of sets use these.

Noise, low volume, sudden change in volume, etc., which are difficult to locate, can often be traced to a broken or high-resistance joint in the cap of a screen-grid tube, caused by the control-grid wire becoming so hot it melts or loosens the solder in the cap. Resoldering will usually repair the trouble.

PHILCO 70 LAZYBOY

VERY bad distortion on loud notes in a Philco 70 Lazyboy was traced to the speaker. This speaker is mounted with the output transformer on top, so that the sealing compound can run out and down around the voice coil. This compound has a low melting point and starts to run when the transformer is only warm. The remedy is to invert the speaker.

BRUNSWICK 16

HIGH-RESISTANCE joints will cause considerable trouble. On a Brunswick 16, the 47 was "lit" but the screen-grids were "dead," although both were on the same circuit and all sockets showed 2.5 V. The poor joint was a heater wire from the pentode to the screen-grids.

SILVER-MARSHALL 36-A

NO CONTROL of volume on a Silver-Marshall 36-A can be traced to one of the .1-mf. condensers in the triple bank. This condenser bypasses the first R.F. and first I.F. cathodes. It may have a high-resistance leak as high as 12 megohms, and still affect the volume control.

CLARENCE E. SWINK

ARBORPHONE 45

QUITE a few of these sets have given fading trouble as well as failing to separate stations. The troubles have been cured by cleaning and soldering the rivets that are used on the "balancing" panel, located on the under-side of the set. The rivets are of one kind of metal and the units they hold of another, which seems to cause corrosion to form. Do not try to balance these sets by ear—balancing by meter makes all the difference in the way the set works.

COLONIAL 32

POOOR tone quality as well as weak reception on some of these sets was found to be due to an open first A.F. bias resistor. This resistor is of the flexible type.

RCA 17 AND 18

SEVERAL of these sets have been encountered in which the customer complained of a scratching noise in the sets—in many instances, almost as loud as the stations received. Taking out the type 26 tubes one at a time and replacing them would cause the noise to stop.

After spending plenty of time testing for the trouble, it was traced to one of the choke coils inside of one of the tuning coils. The bad coil giving this trouble can be located by connecting in series, successively, with each choke coil, a battery and headset. The noisy choke will cause noise in the headset. Since this coil is not sold separately (it is only sold with a complete set of tuning coils) a good repair can often be affected by taking off a few turns of wire; or, by using as replacement an R.F. choke such as the larger types RCA uses in other models, and removing turns of wire until there is about as much wire on the new choke as on the old one.

APEX 10

WHEN this set was tested at the home of the customer, low plate voltages were found all through the set. Rotating the tone control localized the trouble, and by removing the tone control from the front of the chassis correct voltages on the set were obtained.

Upon taking the cover off the control it was found that the small insulating peg, fastened to the arm of the control, was worn to the extent that it was touching the floating disc which regulates the resistance of the control. Making a new insulating peg of fiber, and cementing it to the arm cleared up this trouble without having to order a new tone control.

The same set later developed a hum when the volume control was turned on full. This trouble was cured by replacing one of the electrolytic condensers in the filter circuit which, later inspection showed, had turned green on the inside of the condenser case.

HOWARD EDEN.

JACKSON-BELL 62

I NOTICED, while working on a Jackson-Bell model 62, that the power transformer heated up to a dangerous temperature. Upon examining the set, I found that the chassis had holes in the side for ventilation, but that when the chassis was in the cabinet these holes would not let any air pass through the chassis simply because these ventilating holes were tight against the side of the cabinet.

The best remedy for this, I found, was to drill several holes in the bottom of the cabinet to let air circulate around the transformer.

A. EARNEST SNYDER.

EVEREADY SERIES 50

IVE handled quite a few Eveready Series 50 receivers and in practically all of them the trouble has been found to be the same—the plate bypass condenser for the type 24 tubes seems to go haywire.

The top terminal (of the 3 section condenser) connects to "B+" and one side of the primary of the R.F. coils. It is advisable to disconnect all three and replace with a .5-mf. unit, rated at 300 V., to eliminate second calls.

TELESFOR ZNOTIN.

follow the crowd — they're going "Short-Waves"

THE OFFICIAL DOERLE Short-Wave RECEIVERS 15-200 Meters



YES, the crowds are going "wild" over short-waves; and the Doerle receivers are making them even wilder. Many have built their own and have obtained miraculous results. Others have purchased them already built and have obtained even better results. And why shouldn't they? These receivers, fundamentally, are so simple that they are absolutely fool-proof. As a result, they work ANYWHERE—not only in this country—but in any location. Day after day, night after night and with amazing regularity, they pull in stations from the far corners of the earth—REGULARLY—always on the same points of the dial.

Only parts of the highest quality, such as Hammarlund variable condensers, etc., are employed; for we fully appreciate that "a short-wave receiver is no better than the poorest part going into its construction." All fancy gadgets and embellishments have been entirely removed, only the most fundamental parts necessary for successful operation are employed. You will be impressed with their simplicity. You will be even more impressed with their operation. These receivers will convince you that foreign reception CAN be obtained—and with uncanny regularity—whenever they are on the air.

The Doerle receivers are available in two types, each type consisting of two models. The Electrified Doerle, both the 2-tube and 3-tube models were designed for those localities where electric service is available. They must be used in conjunction with a specially designed hum-free A.C. power pack. The 2-volt battery types were designed for the rural districts. They, too, may be had in 2 and 3-tube models.

It may be possible for you to purchase similar receivers or parts for such receivers at greatly reduced prices elsewhere. We admit this at once. But unless you, too, wish to join the ranks of the disillusioned and skeptical short-wave fans you will insist upon the Official Doerle Receivers—receivers which contain only highest quality parts. All Doerle receivers are built on beautiful, crackle-finished chassis and bear the official name-plate of the only reorganized Doerle manufacturer. All 2-tube models measure 9" x 6" x 6 1/2"; 3 tube models 10 1/2" x 7" x 8".



- No. 2140 2-Tube 12,500 Mile Doerle Receiver Completely Wired and Tested. Shipping Weight 5 lbs. **YOUR PRICE** **\$9.88**
- No. 2142 Complete Accessories. Shipping Weight 22 lbs. **YOUR PRICE** **\$5.38**
- No. 2143 3-Tube Doerle Signal Gripper (Completely Wired and Tested. Shipping Weight 7 lbs. **YOUR PRICE** **\$12.84**
- No. 2145 Complete Accessories. Shipping Weight 22 lbs. **YOUR PRICE** **\$7.19**
- No. 2174 Electrified 2-Tube 12,500 Mile Doerle Receiver Completely Wired and Tested. Shipping Weight 5 lbs. **YOUR PRICE** **\$10.44**
- No. 2176 Complete Set of Tubes for Above; Either 1-57 and 1-56 for A.C. operation or 1-77 and 1-37 for battery operation. **YOUR PRICE** **\$1.60**
- No. 2177 Electrified 3-Tube Doerle Signal Gripper Completely Wired and Tested. Ship. Wt. 7 lbs. **YOUR PRICE** **\$15.29**
- No. 2179 Complete Set of Tubes; Either 1-58; 1-57 and 1-56 for A.C. operation or 1-78; 1-77 and 1-37 for battery operation. **YOUR PRICE** **\$2.50**
- No. 2149 Special Hum-Free A.C. Power Pack including 80 Resistor Tube. **YOUR PRICE** **\$7.25**

Just Imagine! — 2-TUBES



in one
GLASS BULB
—
that's the
"TWINPLEX"

15 to 200 Meters

The new type 53 tube makes possible this Twinplex "double-action" receiver. This tube actually contains 2 separate tubes in the same glass envelope. Just imagine what this means! It means that a 2-tube receiver can now be built for the price of a 1-tube set. This is exactly what has been done in the Twinplex receiver. A comparison of prices with the Doerle 2-tube receivers listed above will immediately substantiate this statement. And what's more, it actually performs like a 2-tube set. The circuit is practically the same as the 2-tube Doerle—extremely simple and therefore entirely fool-proof. You will receive stations which you never knew even existed before. We have received many letters from satisfied users of the Twinplex receiver praising it to the skies. And justly so, for it is a wonderful little set. It affords full band coverage of from 15 to 200 meters which includes the amateur bands, police and airplane calls, foreign reception and numerous code stations.

Only the finest quality parts such as Hammarlund variable condensers, Kurz Kasch high-ratio vernier dials, etc., are employed. All these parts are mounted in a beautiful, crackle-finished metal chassis which entirely does away with "hand capacity."

The receiver is universal in operation which means that it may be operated either with batteries or with an A.C. short-wave power pack. 180 volts is required for the plates of the tubes and 2 1/2 volts, either A.C. or D.C., for the filament. For a fan who is first starting in the short wave game, the Twinplex is the most economical receiver with which to begin.

No. 2115 Twinplex "Double-Action" Short-Wave Receiver Completely Wired and Tested, including diagram but less tubes. Shipping Weight 9 lbs. **YOUR PRICE** **\$7.50**

FAMOUS Oscillodyne 1-TUBE WONDER SET 15-200 Meters

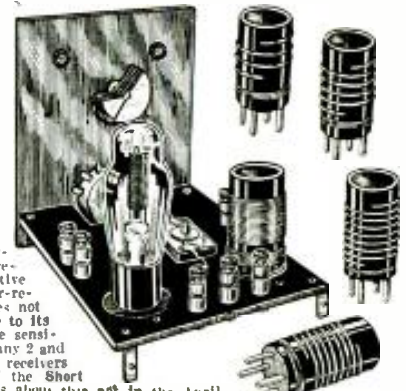

And a wonder set it is at that! Although the circuit of this unique little receiver is of the regenerative type, it acts like a super-regenerative set; yet it does not belong in that class. Due to its peculiar circuit it has the sensitivity and selectivity of many 2 and even 3-tube short-wave receivers.

Read what the editor of the Short Wave Craft Magazine says about this set in the April, 1933, issue: "We are pleased to present to our readers an entirely new development in radio circuits—the Oscillodyne. This circuit which is of the regenerative variety, acts like a super-regenerative set. Its sensitivity is tremendous. The editor, in his home on Riverside Drive, New York City, in a steel apartment building, was able to listen to amateurs in the midwest, USING NO AERIAL AND NO GROUND. With the ground alone, a number of Canadian stations were brought in, and with a short aerial of 40 feet, many foreign stations were easily pulled in."

Here then is a set which brings in stations thousands of miles away; a set which frequently brings in Australia, loud enough to rattle your phones and with power to spare; a set which if you do not wish extreme distance will bring in stations several thousand miles away without aerial or ground. And the many hundreds of testimonial letters from short-wave fans who have either built their own or have purchased them, fully substantiate these remarkable results. The receiver may be used either with batteries or A.C. power pack. Requires a 227 tube for battery operation and a 227 for A.C. operation. Available either completely wired ready to use or in kit form. Four pages of detailed instructions and diagrams are included with each set. The aluminum panel 8" high x 1 1/2" wide. The bakelite base is 5 1/2" long x 1 1/2" wide. Shipping Weight 3 lbs. No. 2146 Official One-Tube Wonder Set, completely wired and tested. **YOUR PRICE** **\$7.20**

No. 2147 Official One-Tube Wonder Set, in kit form, with detailed construction plans. Shipping Weight 3 lbs. **YOUR PRICE** **\$6.35**

No. 2148 Complete Accessories, including the following: one 37 tube; set of standard headphones; four No. 6 dry cells; two 45-volt "B" batteries. Shipping Weight 22 lbs. **YOUR PRICE** **\$5.50**

WE ISSUE NO CATALOG

All orders are F. O. B. New York. Terms: A deposit of 20% is required with every order. Balance may be paid on delivery. Deduct 2% if full amount is sent.

GREN PARK COMPANY

245 Greenwich St. Dept. RC New York, N. Y.

RTC's Big June SPECIALS

YOUR DOLLAR— IS WORTH MORE When You Buy From Us

Is the dollar inflated? These days everybody is speaking of inflation but why worry about it, whether the dollar is inflated or not it is worth more when you buy from us. The prices shown on this page are so radically low that no one can possibly undersell them. Our consistent advertisements present to you each month, on this page, certain STAR (*) items which are not listed in our regular catalog. These are all specials of which the small quantity on hand does not permit us to catalog them. **ONCE SOLD OUT NO MORE CAN BE HAD AT ANY PRICE. ORDER TODAY—NOW.** Order direct from this page and save money. 100% satisfaction guaranteed on every transaction.

We are a wholesale house and cannot accept orders for less than \$3.00. If C.O.D. shipment is desired, please remit 20% of the total amount of your order. Balance will go forward C.O.D.

If full cash accompanies your order deduct 2% discount. Send money order, certified check or U. S. stamps.

Be sure to include sufficient extra remittance if order is to be shipped via parcel-post; any excess will be refunded.



FREE

RADIO and Short-Wave TREATISE

108 Pages 1500 illus.

Completely revised and enlarged, this new 1934 edition contains 108 solid pages of useful radio information, diagrams, illustrations, radio kinks and real live radio merchandise. It contains more valuable radio information—more real live "meat"—than many text books on the subject. **PARTIAL LIST OF CONTENTS:** Fundamental Principles of Radio for the Beginner, Chapter 2—Fundamental Circuits and Uses of New Tubes—Revamping Six Volt Battery Sets for Two Volt Tubes—Public Address Systems—How to Build Short Wave Transmitters and Receivers—Up to Date Tube Chart and Socket Connections, etc., etc. **WRITE TODAY!**—Enclose the cents (coin) for postage. Treatise sent by return mail. Print name and address clearly on request.

GREATEST SET BUY IN AMERICA!

★ Famous Wright-DeCoster VII Battery Receiver

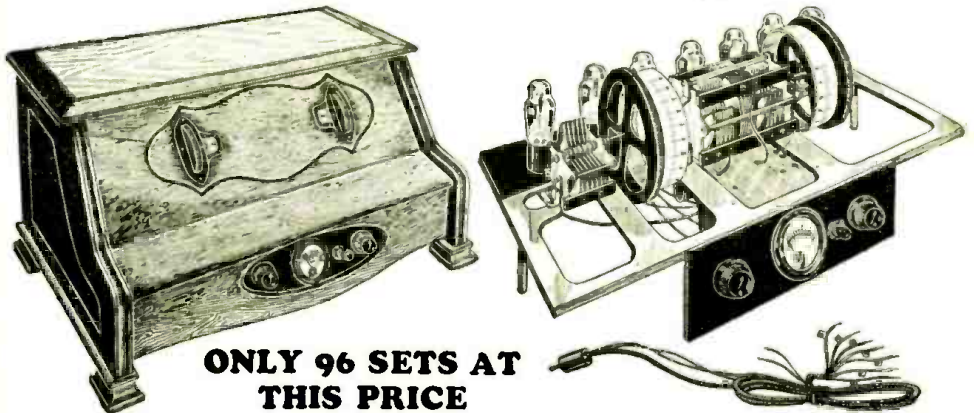

ONLY 96 SETS AT THIS PRICE

\$14.95

If there ever was a greater value than this one offered before, we have yet to see it. The Wright-DeCoster VII receiver, in its prime, several years back sold for \$300.00, and tens of thousands of them were sold, yet now you can buy this same set unused and in factory sealed cartons for only a fraction of that price, to be exact \$14.95! Why, the parts alone in this receiver, if taken out and sold separately would net you more than \$25.00; to say nothing of the beautiful cabinet. The dual scale Jewell meter alone, today, sells for more than \$5.00.

But aside from all this, the set itself affords remarkable performance. The selectivity and sensitivity, due to its 4-tuned stages are just as sharp as a modern super-heterodyne receiver. The circuit is of the tuned radio frequency type designed originally for 4-UX-100's and 1-UX-120, however, 2-VOLT OPERATION MAY BE OBTAINED WITHOUT ANY CHANGE IN THE CIRCUIT BY MERELY INTERCHANGING THE '99 TUBES WITH 30'S AND THE UX-120 WITH A 31. The use of the 2-volt tubes steps up the overall gain and volume of the set enormously. The circuit comprises 3 stages of R.F. amplification, one detector and 3 stages of audio amplification. It tunes in, and completely separates, stations of the same approximate wave-lengths with facility—a quality so necessary to the enjoyment of the present day radio with its ever increasing number of broadcast stations of very similar wave-lengths.

Furthermore the range of this receiver is so great that it will bring in the most distant station. We do not hesitate a moment in recommending it, especially to suburbanites and others living in rural districts. It is an ideal farm set

where electricity is not available. The set is designed for the greatest comfort of the operator. All unnecessary controls are eliminated. The tuning dials may be illuminated for night operation by turning a switch on the panel. The Jewell meter on the panel affords an indication of the voltage on the tube filaments and thereby protects them.

THE WRIGHT-DECOSTER VII does not radiate or cause interference of any kind. It gives maximum efficiency on all broadcast ranges and will operate with any length of aerial. If used with the 99 and 20 tubes, 4 volts of "A" current, 135 volts of "B", 22½ volts of "C", are required. If used with 30 and 31 tubes only 3 volts of "A" (2 No. 6 dry cells arranged in series), 135 volts of "B" and 10½ volts of "C" are required.

The cabinet, made of black walnut with satin finish is of a very beautiful design. The dial readings are directly in front of the operator's eyes and fine tuning is obtained by thumb action. The receiver can be used with any good magnetic speaker or even with a permanent magnet dynamic speaker if one is handy. The set measures 24" long x 15" wide x 12" high. Shipping weight 45 lbs.

No. 3000 Wright-DeCoster VII Battery Receiver.

YOUR PRICE, Less Tubes..... **\$14.95**

Set of 6—230 and 1—231 guaranteed Neontron RCA licensed tubes\$5.25

ONLY 96 AT THIS PRICE. ONCE SOLD NO MORE WILL BE HAD. WE BOUGHT THE ENTIRE SUPPLY FROM MANUFACTURER. NO ONE ELSE HAS THESE FINE SETS.



WORLD-WIDE RECEPTION WITH THE FAMOUS "TWINPLEX" Short-Wave Receiver

2-Sets in-1

Economical 2-Volt Operation Complete with Headphone

ONLY \$4.95



SHORT waves are the talk of the hour. The whole country, nay, the whole world, has gone crazy to receive foreign stations, as far as 12,500 miles distant. Usually, such reception is had only with expensive multi-tube sets.

Only recently the invention of the "19" tube has made it possible to perform the function of two tubes in a single tube. Then came the invention of the TWINPLEX, a radio circuit of unheard of sensitivity, using the "19" tube in a single tube set, a single tube of this type to receive short wave stations from all over the world, loudly and clearly—REGULARLY, night after night, day after day, always in the same place on the dial.

Every radio man knows that in a short-wave set it is highly important to have the wiring as short as possible. By inventing a radically new design, that is, by mounting tube and coils, in fact, everything, on the front panel, it has become possible to shorten all connecting wires, with the result that an **UNHEARD OF SIGNAL SENSITIVITY** has now been achieved for the first time, in a single-tube set.

But the TWINPLEX IS ACTUALLY A TWO-TUBE SET; yes, we repeat, A FULL-FLEDGED TWO-TUBE SET AT THE PRICE OF A ONE-TUBE SET.

JUST IMAGINE, TWO TUBES IN ONE GLASS ENVELOPE. That is the story of the new "19" tube. It is a 2-volt tube, which has a **DOUBLE SET OF ELEMENTS.**

This set has been so designed that it will receive ordinary broadcast stations too—stations which come in with great volume, particularly local stations. These come in

so loud that if you have a loudspeaker, this little one-tube set will **ACTUALLY GIVE YOU LOUDSPEAKER RECEPTION.**

With this set, we furnish regularly, two coils, one a short-wave plug-in coil, which receives all the popular stations in the 33 to 65 meter band, and a broadcast coil which receives nearly all broadcast stations.

A stippled instruction sheet with detailed instructions and pictorial diagrams shows you how to build the set in a few hours' time, and once you have completed the set, FROM THEN ON, YOU DON'T SLEEP ANY MORE.

ONLY FIRST CLASS MATERIAL, such as Hammarlund tuning condensers, Polymet mica condensers, R.M.A. standard resistors, etc., are employed.

The "19" TWINPLEX is available **ONLY** in kit form and comprises all parts to properly build the receiver in from 1 to 2 hours. **ANYONE CAN DO IT.** Shipping weight 5 pounds.

No. SW-308 Famous Twinplex Short-Wave Receiver Kit with all parts INCLUDING SINGLE HEADPHONE AND BAND BUT NO TUBE **\$4.95**

YOUR PRICE.....

No. SW-309 Complete Accessories for TWINPLEX Receiver, Comprising 1—Type 19 Tube, 2—No. 6 Dry Cells, 2—45 volt "B" Batteries. Shipping weight 20 pounds. **\$3.56**

Additional Plug-in Coils—45c each

RADIO TRADING COMPANY, 102 Park Place, New York City

Penny Wise - BUT Dollar PROFIT

To Every
Radio Manufacturer
Jobber and
Mail Order House

This issue of RADIO-CRAFT concludes the first five-year period since the magazine's inception.

With no little effort and persistence, the publishers have succeeded in bringing out sixty consecutive issues. It is a testimonial to the merits of any magazine that, in its infancy, it was able to pass successfully through the crucial, depression days. And, NOW, RADIO-CRAFT has become the second largest radio monthly magazine in the country. Such success is due in great measure to its splendid, enthusiastic organization.

In this half-decade, RADIO-CRAFT has attained a circulation far in excess of 50,000 monthly readers, comprising manufacturers, jobbers, radio dealers, service men, radio engineers, experimenters and professional set builders. Present indications point to a fair percentage of increase during the next few months. What does the future hold? Well, we're confident of continued success.

We recall the early days when only a handful of advertisers were represented in the pages of RADIO-CRAFT. Today, we find an average of 50 or more advertisers using space regularly month after month. Many of them have never missed an issue since July, 1929.

The growth of RADIO-CRAFT in circulation, in prestige, in editorial interest, in value as an advertising medium, is conclusively proved by the results obtained by one of many advertisers. The letter reproduced is JUST ONE of any number of unsolicited letters received from time to time. It points out clearly the profits derived from advertising expenditures in RADIO-CRAFT — it shows reader response to advertising in RADIO-CRAFT — and it proves leadership in the radio field.

Advertisers and agencies are alert in taking advantage of new, prosperous markets. What greater prospects in a constantly buying field can be found? Where can a more active radio market be established? We know by confidential reports from other advertising accounts that results have ALWAYS been good. It's money invested wisely to bring dollar profits.

THE PUBLISHERS.

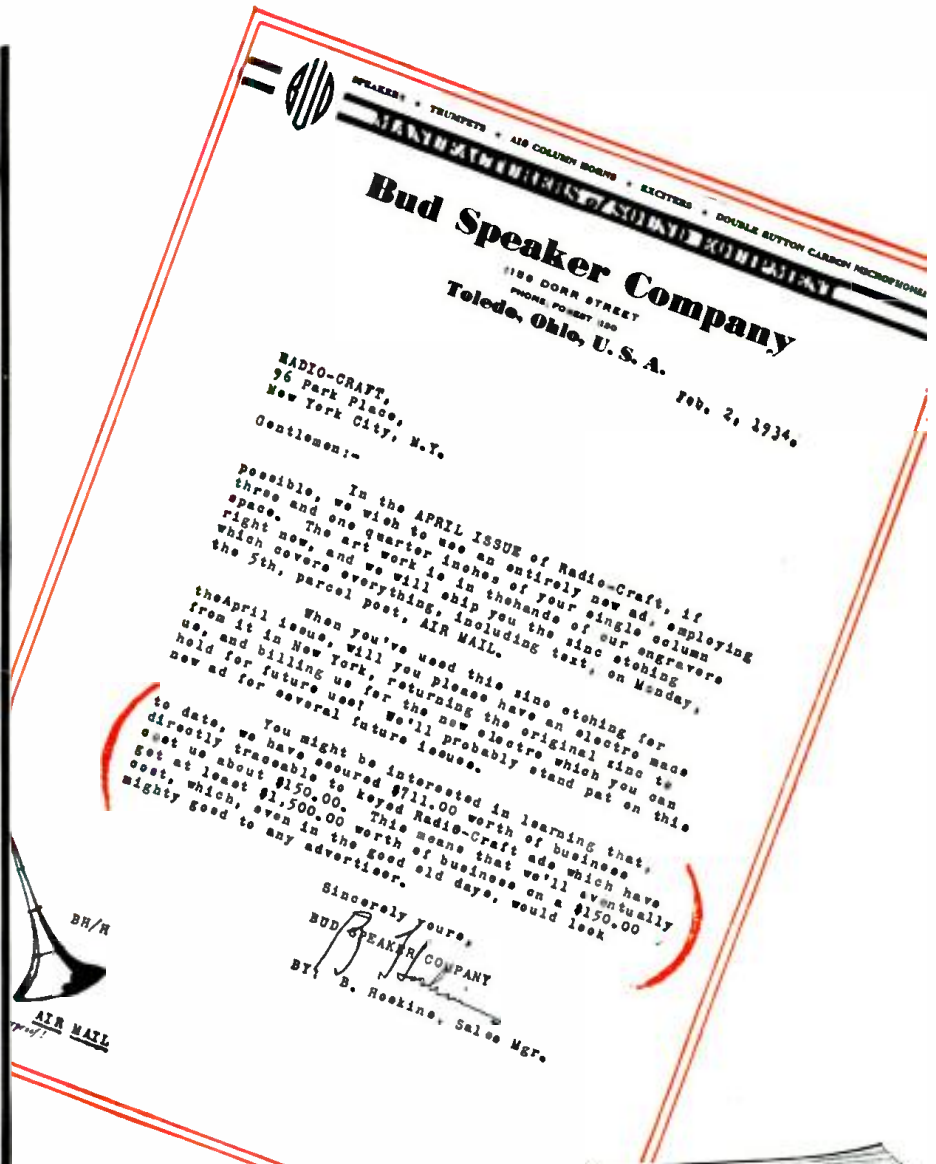

RADIO-CRAFT

Published by Continental Publications, Inc.

96-98 PARK PLACE

New York, N. Y.

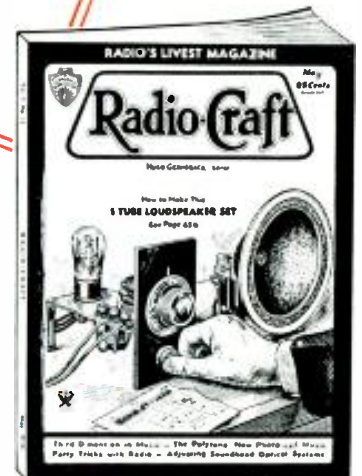

TRAIN
with **R.T.A.**
for **RADIO**
SERVICE
WORK.

This precision Analyzer and Point to Point Resistance Tester included with our training. It is of the latest design and construction, will test all circuits equipped with latest six and seven-pin tubes, and cannot become obsolete or out of date. Equipped with an improved type 2% D'Arsonval Meter, etc.



Learn at home
to fill a **GOOD PAY RADIO**
JOB!

**SKILLED SERVICE MEN
ARE NEEDED**

Skilled service men are needed now more than ever to service the modern all-electric radio receivers. The day of the tinkerer is gone. By becoming a certified R.T.A. Radio Technician you can make bigger money, full time or spare time, and fit yourself for the big-pay opportunities that Radio offers.

TRAIN AT HOME—NOW

Now is the time to get ready for these better pay radio jobs. Our training will qualify you quickly. In addition we furnish you, *free of extra charge*, a high grade Precision Analyzer and Point to Point Resistance Tester. This remarkable instrument, together with our training, will enable you to do expert work in a short time.

\$5 to \$15 A WEEK—EXTRA

Our training is practical and designed to help you make extra money at the very start. With the first lesson I give you a series of over thirty spare-time Money Making Plans that will enable you to make from \$5 to \$15 a week extra, and more.

RADIO TRAINING ASSOCIATION OF AMERICA
Dept. R-6 4513 Ravenswood Ave. Chicago, Ill.

**ALL THE LATEST CIRCUITS
ARE INCLUDED**

Our training is up-to-the-minute and thorough in every detail. All late subjects are covered—automatic volume control, R.F. pentodes, diode detection, delayed and amplified A.V.C., automatic noise suppression, dual channel audio amplification, all-wave superheterodynes, acoustically compensated volume control, etc.

**ENDORSED BY LEADERS
OF THE INDUSTRY**

Our modern training is endorsed by Leaders of the Radio Industry. We have in our files over thirty letters from them recommending our training to those who want to make good quickly in radio.

Mail Coupon—Now

RADIO TRAINING ASSOCIATION OF AMERICA
4513 Ravenswood Ave., Dept. R-6
Chicago, Ill.

Gentlemen—Please rush me more details of your practical endorsed training course in Radio.

Name

Address

City State