



34

September

25 Cents

Canada 30c

Radio-Craft

HUGO GERNSBACK Editor

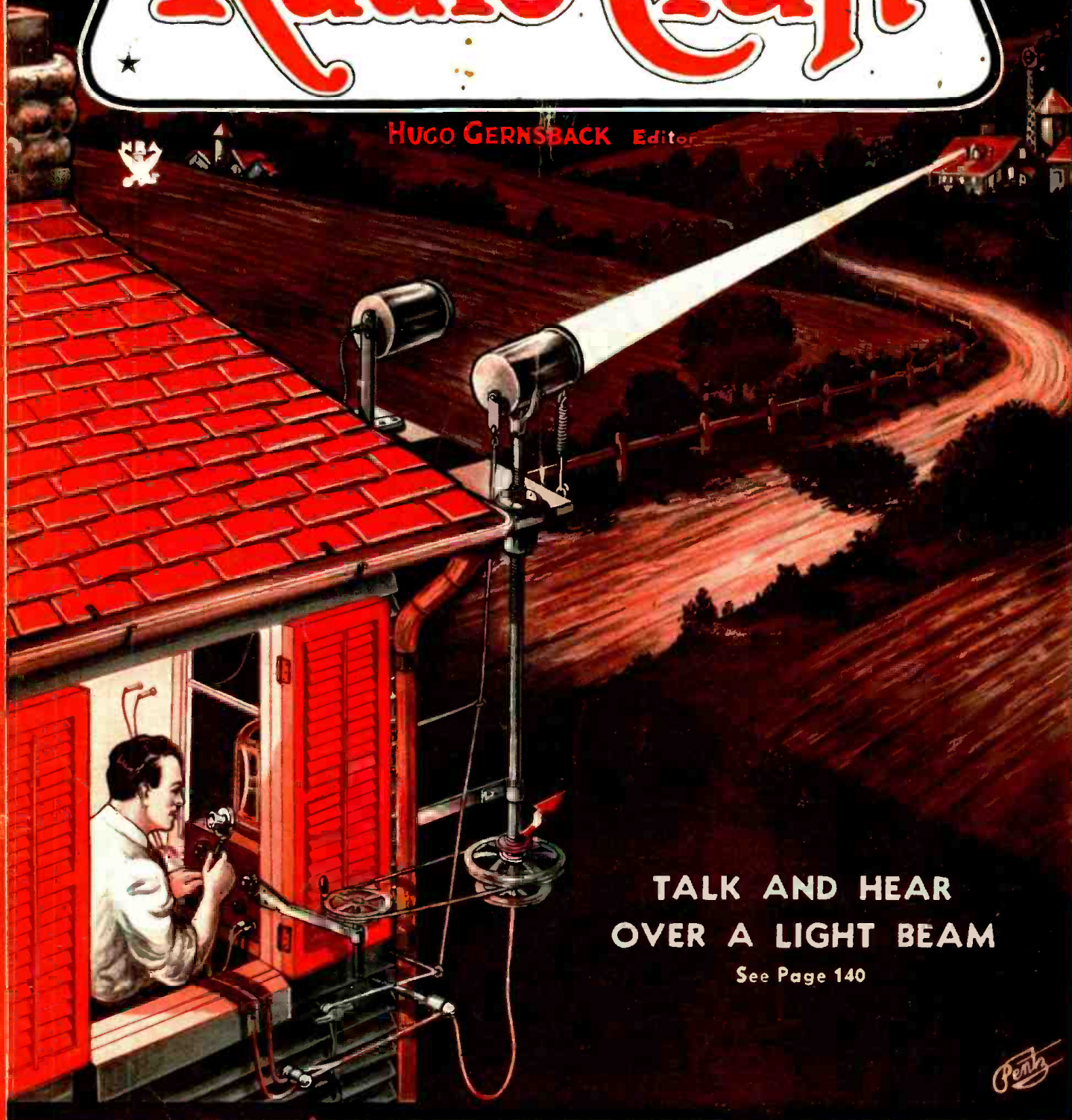

TALK AND HEAR
OVER A LIGHT BEAM

See Page 140

Perry

High-Fidelity Amplification — Converting Old Sets — Repairing Cones
How Shielded Lead-Ins Misbehave — Grid Dip Oscillator — New P. A. Horns

OPPORTUNITIES *are many* for the Radio Trained Man

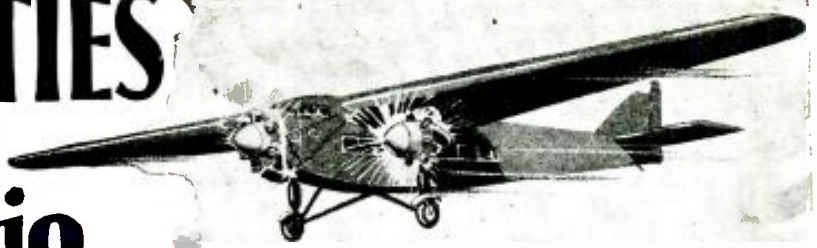

Don't spend your life slaving away in some dull, hopeless job! Don't be satisfied to work for a mere \$20 or \$30 a week. Let me show you how to get your start in Radio — the fastest-growing, biggest money-making game on earth.

Jobs Leading to Salaries of \$50 a Week and Up

Prepare for jobs as Designer, Inspector and Tester—as Radio Salesman and in Service and Installation Work—as Operator or Manager of a Broadcasting Station—as Wireless Operator on a Ship or Airplane, or in Talking Picture or Sound Work—HUNDREDS OF OPPORTUNITIES for a real future in Radio!

Ten Weeks of Shop Training **Pay Your Tuition After Graduation**

We don't teach by book study. We train you on a great outlay of Radio, Television and Sound equipment—on scores of modern Radio Receivers, huge Broadcasting equipment, the very latest and newest Television apparatus, Talking Picture and Sound Reproduction equipment, Code Practice equipment, etc. You don't need advanced education or previous experience. We give you—RIGHT HERE IN THE COYNE SHOPS—the actual practice and experience you'll need for your start in this great field. And because we cut out all useless theory and only give that which is necessary you get a practical training in 10 weeks.



TELEVISION *and* TALKING PICTURES

And Television is already here! Soon there'll be a demand for THOUSANDS of TELEVISION EXPERTS! The man who learns Television now can have a great future in this great new field. Get in on the ground-floor of this amazing new Radio development! Come to COYNE and learn Television on the very latest, newest Television equipment. Talking Picture and Public Address Systems offer opportunities to the Trained Radio Man. Here is a great new Radio field just beginning to grow! Prepare NOW for these wonderful opportunities! Learn Radio Sound Work at COYNE on actual Talking Picture and Sound Reproduction equipment.

PAY FOR YOUR TRAINING ***After You Graduate***

I am making an offer that no other school has dared to do. I'll take you here in my shops and give you this training and you pay your tuition after you have graduated. Two months after you complete my course you make your first payment, and then you have ten months to complete your payments. There are no strings to this offer. I know a lot of honest fellows haven't got a lot of money these days, but still want to prepare themselves for a real job so they won't have to worry about hard times or lay offs.

I've got enough confidence in these fellows and in my training to give them the training they need and pay me back after they have their training.

If you who read this advertisement are really interested in your future here is the chance of a life time. Mail the coupon today and I'll give you all the facts.

ALL PRACTICAL WORK ***At COYNE in Chicago***

ALL ACTUAL, PRACTICAL WORK. You build radio sets, install and service them. You actually operate great Broadcasting equipment. You construct Television Receiving Sets and actually transmit your own Television programs over our mod-

ern Television equipment. You work on real Talking Picture machines and Sound equipment. You learn Wireless Operating on actual Code Practice apparatus. We don't waste time on useless theory. We give you the practical training you'll need—in 10 short, pleasant weeks.

MANY EARN WHILE LEARNING

You get Free Employment Service for Life. And don't let lack of money stop you. Many of our students make all or a good part of their living expenses while going to school and if you should need this help just write to me. Coyne is 33 years old. Coyne Training is tested—proven beyond all doubt. You can find out everything absolutely free. Just mail coupon for my big free book!

H. C. Lewis, Pres. RADIO DIVISION Founded 1899
COYNE ELECTRICAL SCHOOL

500 S. Paulina St., Dept. 64-8H Chicago, Ill.

Mail Coupon Today for All the Facts

H. C. LEWIS, President
Radio Division, Coyne Electrical School
500 S. Paulina St., Dept. 64-8H Chicago, Ill.

Dear Mr. Lewis:—Send me your Big Free Radio Book, and all details of your Special Offer, including your "Pay After Graduate" offer.

Name

Address

City State

I will send you a Lesson Free



J. E. SMITH, President, National Radio Institute, Washington, D. C. — the man who has directed the training of more men for the Radio industry than any other man in America.

to show how easy it is to learn at home in spare time to fill a

Good Radio Job

Clip and mail the coupon. I'll send you a FREE lesson. I'll show you that Radio is fascinating; that I give you practical money-making information, easy to learn, easy to put into use. See for yourself why many men with less than a grammar school education and no Radio experience have become Radio experts at two and three times what they were making before they enrolled with me. Get the facts about Radio's spare time and full time job opportunities.

Many Radio Experts make \$40, \$60, \$75 a week. Get ready for Jobs like these

Broadcasting stations employ engineers, operators, managers, and men for other jobs that pay up to \$5,000 a year. Radio factories employ testers, inspectors, foremen, engineers, servicemen, salesmen, buyers, and pay up to \$7,500 a year. Radio dealers and jobbers employ servicemen, salesmen, buyers, managers, and pay up to \$100 a week. There are many opportunities to have a spare time or full time service or retail Radio business of your own. Radio business is picking up. It's a big business—big enough to absorb many more well trained men—growing bigger all the time. Get ready for Radio. Be a Radio Expert. I'll train you at home in spare time.

Many make \$5, \$10, \$15, a week Extra in Spare Time while learning

Nearly every neighborhood needs a good spare time serviceman. Find out how I help you cash in—how I send you directions, the day you enroll, for doing 28 Radio jobs. How, when you get underway, I send you much more information for servicing sets and for doing other spare time jobs for extra money. Many make \$200 to \$1,000 while learning.

Short Wave, Loud Speaker Systems, Television, Auto Radio, etc., included

Radio is growing. Loud speaker systems, police, auto and aviation Radio, are recent new uses that have been found for it. Television promises many good jobs soon. Here is a field with a future. Get full information about it—how I train you at home in spare time to be a Radio Expert. My 50-50 method of training—half with printed and well illustrated lessons, half with Radio equipment and directions for conducting experiments—gives you broad practical experience while learning—makes learning at home interesting, fascinating, practical.

You must be Satisfied

I make this agreement with you in writing—if you are not entirely satisfied when you finish my Course, with the lesson and instruction service I have given you, every penny you have paid me for tuition will be refunded.

Get my book on Radio's Opportunities. Get a Free Lesson too

Mail coupon now. I'll send you "Rich Rewards in Radio" and a FREE lesson at once. Find out about Radio's spare time and full time opportunities; read what others who have taken my Course are doing and making. Read the lesson, decide for yourself whether my training is clear, interesting, practical. There is no obligation. Act at once. Mail coupon in an envelope or paste on a 1c card. Do it right now.

**J. E. SMITH, President
National Radio Institute, Dept. 4JX
Washington, D. C.**



SET SERVICING has paid many N.R.I. men \$5, \$10, \$15 a week extra for their spare time. Full time men make as much as \$40, \$60, \$75 a week.



BROADCASTING STATIONS employ many technically trained men for interesting, fascinating jobs paying up to \$100 a week.



LOUD SPEAKER SYSTEMS, one of Radio's newest developments, gives interesting, well-paying jobs to many.



I have doubled and tripled the salaries of many

MAIL THIS TODAY

Good for FREE SAMPLE LESSON and BOOK on RADIO'S OPPORTUNITIES

J. E. SMITH, President
National Radio Institute, Dept. 4JX
Washington, D. C.

I want to take advantage of your offer. Without obligating me, send me your Free Sample Lesson and your book, "Rich Rewards in Radio." (Please print plainly.)

NAME AGE

ADDRESS

CITY STATE "R"

The Tested Way to BETTER PAY

Radio Men!

**GOOD BOOKS WHICH HELP
MAKE RADIO WORK MORE PROFITABLE**

Presented on this page are books of the RADIO-CRAFT LIBRARY SERIES—a most complete and authentic set of volumes treating individually, important divisions of radio. Each book has been designed to give radio men the opportunity to specialize in one or more of the popular branches of the industry. You will find them a real help in your work and they will contribute to your money earning capacity. Read these books during your spare time at home.

The authors of these books are well-known to everyone. Each is an expert radio man; an authority on the subject—each is thoroughly familiar with the field which he represents.

This is the first real opportunity that you have ever had to build a library of radio books that are authentic. **MOST OF THE BOOKS HAVE BEEN RECENTLY REVISED AND REWRITTEN TO KEEP THEM UP TO THE MINUTE.** Mail coupon below for your books.

Book No. 1
Radio Set Analyzers
And How to Use Them
By L. VAN DER MEL
With Full Instructions and Descriptions of Set Analyzers, Tube Checkers, Oscillators, etc. (Just revised.)

Book No. 2
Modern Vacuum Tubes
And How They Work
By ROBERT HERTZBERG
With complete Technical Data on All Standard and Many Special Tubes. (Just revised.)

Book No. 3
The Superheterodyne Book
All About Superheterodynes
By CLYDE FITCH
How They Work, How to Build and How to Service Them.

Book No. 4
Modern Radio Hook-Ups
The Best Radio Circuits
By R. D. WASHBURNE
A Complete Compendium of the Most Important Experimental and Custom-built Resolvers.

Book No. 5
How to Become a Radio Service Man
By LOUIS MARTIN
How to get started in the business of servicing radios and how to make money in this field.

Book No. 6
Bringing Electric Sets Up to Date
By CLIFFORD E. DENTON
With Pentodes, Multi-Mus, Dynamic Speakers—Complete Information How to Modernize A. C., D. C. and Battery Operated Receivers.

Book No. 7
Radio Kinks and Wrinkles
By C. W. PALMER
For Service Men and Experimenters
A Complete Compendium on the Latest Radio Short-Cuts and Money Savers—These Kinks Are Great Time-Savers.

Book No. 8
Radio Questions and Answers
By R. D. WASHBURNE
A Selection of the Most Important of 5,000 Questions Submitted by Radio Men During the Course of One Year—They Are All Answered by a Technical Expert.

Book No. 9
Automobile Radio and Servicing
By LOUIS MARTIN
A Complete Treatise on the Subject Covering All Phases from Installing to Servicing and Maintenance. A Book That Is Greatly Needed Today. (Just Revised.)

Book No. 10
Home Recording and All About It
By GEORGE J. SALIBA
A Complete Treatise on Instantaneous Recordings, Microphones, Recorders, Amplifiers, Commercial Machines, Servicing, etc.

Book No. 11
Point-to-Point Resistance Measurements
By CLIFFORD E. DENTON
The Modern Method of Servicing Radio Receivers—A Book Which Radio Service Men Have Referred to More Than Any Other.

Book No. 12
Public Address Installation and Service
By J. T. BERNSELY
Modern Methods of Servicing and Installing Public Address Equipment.

Big Discount To You
In order to make it possible for everyone to buy these books, the fifty (50) cent price has been made uniform for all volumes. You can buy these books separately, but you should take advantage of our special offer:
When Five (5) Books Or More Are Ordered Deduct 20% From Your Remittance
Simply fill in the coupon at left, and mail it to us together with your remittance. Checks, stamps or money orders accepted.

Here are the subjects covered--

- Set Analyzers
- Tubes
- Superheterodyne Circuits
- Radio Hook-ups
- Servicing Business
- Modernizing Electric Sets
- Kinks and Wrinkles
- Questions and Answers
- Auto-Radio Servicing
- Home Recording
- Resistance Measurements
- Public Address

All Books Uniform Volumes are all uniform size, 6 x 9 inches, and contain on an average of 50 to 120 illustrations. Each book is printed on fine paper and no expense has been spared to make it an outstanding value.



CLIP-MAIL THIS COUPON TODAY!

GERNSBACK PUBLICATIONS, INC., 99 Hudson Street, New York, N. Y.

I have circled below the numbers of books in the RADIO-CRAFT LIBRARY SERIES which you are to send me, and have deducted 20% for ordering five (5) books or more. I have included my remittance in full, at the price of 50c each, when less than five books are ordered.

The amount of my remittance is.....(Stamps, checks or money orders accepted.)

Circle numbers wanted: 1 2 3 4 5 6 7 8 9 10 11 12

Name Address

City State RC-931



“Takes the Resistance out of Radio”

Editorial Offices: 99 Hudson St., New York, N. Y.

HUGO GERNSBACK, Editor

Vol. VI., No. 3, Sept., 1934

RADIO TELEMECHANICS

An Editorial by HUGO GERNSBACK

ONE of the branches of the radio art—although one of the most spectacular—is very seldom heard of, even among radio technicians. This is to be regretted, because there is a great future in store for this particular branch of radio.

By Radio Telemechanics is meant that art whereby it is possible to perform work at a distance, without the presence of man.

Not so many years ago, the United States Navy sent one of their obsolete battleships from shore, out into the ocean, without a single human being on board the ship. Yet the ship was made to run in any direction desired; it could turn to port or starboard, in a circle; the stoking of its boilers was attended to; guns were discharged all from shore, without a human being on board having anything to do with the entire operation of the vessel. It all resolved itself into impulses sent by radio to the ship, where they were correctly interpreted and the ship made to obey these impulses.

The same thing can, of course, be done with airplanes—the French government, having experimented extensively with this idea, frequently sending airplanes aloft without anyone being on board. The airplane, in these tests, was made to undergo its usual routine of rising, heading into the wind, circling about at will; later on returning and making a perfect landing, all by radio control from the ground.

Fundamentally the idea is simple. Radio impulses are sent out, which are received on a certain wavelength over an especially engineered radio set. A small motor continues making contacts at certain stated intervals; in a series which must be known to the control operator on the ground. By using either a different wavelength or different impulses, the desired effects are translated into action, on board a ship or airplane as the case may be; a relay mechanism operated by the impulses performs, in turn, the required work demanded by ship or airplane, etc.

Radio technicians will also be interested to know that lately experiments have been made whereby it is possible to do all this on a single wavelength or frequency, by means of *tuned audio amplifiers*. In other words, suppose we have a special receiving set installed on an airplane. The man on the ground, with his transmitter, will have a half-dozen *tuned whistles*, which he will blow in front of a microphone. Each sound is interpreted by the receiving set on board the plane; the sounds being filtered from each other so that each separate sound can be used as a directing means.

While all this may seem complicated, in practice it really is not so. In fact, the art is becoming simplified more and more. Naturally, the thought comes to everyone that in wartime such a radio-controlled airplane would not be of much use, because the enemy could interfere by sending similar impulses. *That is not necessarily so.*

The well-known inventor, John Hays Hammond, Jr., has a number of radio patents on this particular branch of telemechanics, whereby it becomes possible, by locking mech-

anisms, to prevent the receiving set from operating unless a certain sequence of signals is sent at certain intervals; and without that key, you cannot do much damage because, no matter what the interference would be, you would still not be able to interfere with the correctly keyed radio impulses.

There are many applications in industry and the sciences for radio telemechanics. For instance, high-tension switches can be operated, if necessary, over great distances, when the necessity arises. Doors can be opened, elevators can be run; as a matter of fact, almost anything that you can think of in mechanics can be accomplished at a distance should this become desirable, all by radio telemechanics.

In wartime, of course, the operation of small war vessels such as submarines, torpedo boats, bombing planes, etc., all can be operated without any senseless cost of human life when it becomes necessary to so operate war weapons. The same is true in the case of tanks, mines, and other war machines.

No doubt, it will also occur to most readers immediately, that, in the instance of an airplane, the radio control does not mean much if you cannot see what the airplane is doing. For example, if you were to send an airplane aloft, how would you keep it from dashing into a mountainside, if you could not see where it was going?

The answer to this is television. Many years ago, I made the proposal of a war airplane which I termed “The Radio-Controlled Television Airplane.” In this particular instance, the airplane is radio-controlled from the ground. In addition to the radio impulses, the airplane also has on board a television outfit which sees in six directions simultaneously. This is easily accomplished by a system comprising photoelectric cells, and lenses, one looking upward, one downward, and one, each, looking east, west, south, and north. These “photoelectric lenses” are all connected with the television transmitter. The television impulses are then sent from the plane to headquarters where an operator sits in front of a screen divided into six parts. From this, he will see exactly where the airplane is at any time. He not only will see over what territory the plane is moving, but he also will see if there is another airplane overhead attacking it. By means of his radio-control mechanism he can thus guide the plane in any manner he sees fit. He can bring it back to his own lines, or he may send it over enemy lines, or he may make the airplane perform any duties he sees fit.

The same instrumentality can, of course, be used in connection with submarines, warships, tanks, automobiles, etc., and to be certain, a like instrumentality can be applied to peacetime uses as well. There is, in fact, no limit to which the system cannot be applied.

Radio telemechanics is a comparatively new art. It is a most fascinating branch of radio, one that will become of great importance as time goes on.

It has many uses which have not, as yet, been dreamt of.

THE RADIO MONTH



ONE OF THE TRADE BUILDERS
W2XAF at Schenectady.—One of the most consistent "foreign" stations in South America.

RADIO— A TRADE BUILDER

RADIO broadcasting has, within the past month or so, entered into a new era, that of aiding international commerce.

Trade propaganda as an adjunct to musical entertainment is being sent to South America from Berlin and Paris, and arrangements have been made between the Argentine and the British as well as the Italian governments to intercept programs for rebroadcast. For all of these broadcasts, announcements are in Spanish and in most cases Argentine announcers are used. The transmissions are gratis as far as South America is concerned.

In answer to the challenge of these European companies to vie for South American business by means of good will established through international short-wave broadcasts, a representative of the NBC made the following statement during the past month. "We will match the foreign efforts program by program, in fact, we will trump them. If it is to be a battle of music and words, we will be in the thick of the fight. Our programs will be chiefly entertainment. In addition to an average of 10 Pan-American programs we are now broadcasting, we plan to add at least 4 fifteen-minute short-wave presentations. We sent the Carnera-Baer fight down there in Spanish, and anything of that nature that comes along we will broadcast as a special event."

Most European broadcast facilities

are directly under the supervision of their respective governments and it may safely be interpreted that these South American broadcasts are direct efforts on the part of these governments to obtain part of the large South American trade. However, inquiry made at the NBC revealed that the United States government has made no direct request to compete with the foreign broadcast facilities in the "war" for South American trade.

BBC'S 24 HOUR CLOCK

THE announcement last month by the British Broadcasting Corp. of experiments with a 24 hour clock is marked by incidents of advocacy and opposition similar to those which accompany every campaign for daylight saving time. An article in the *London Times* by a well known correspondent foresees possible difficulties resulting from the BBC system and the reckoning used by seamen: "In the former case, the 24 hours are reckoned from midnight to midnight and in the latter from noon to noon. The astronomical system (used by seamen) obviously starts from noon when the sun reaches its highest point above the horizon on the meridian of the observer and with the 24 hour clock used by the navigators, 12 hours are added to the clock only after midnight. With the increasing intercommunication by 'wireless' between ship and shore stations it would seem regrettable if, in the event of any change in the present system being made, the case for uniformity should not be considered from this point of view as well."

THE 24 HOUR CLOCK OF THE BBC
Which is raising much controversy with the English radio fans.

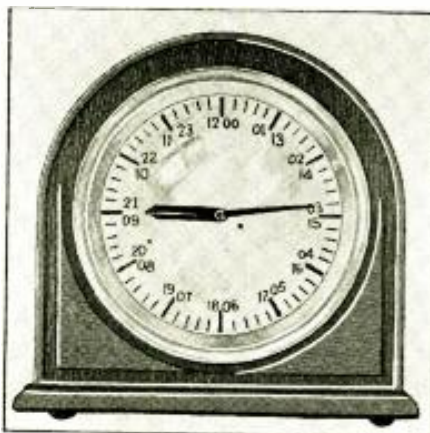

We wonder if this correspondent considered the fact that the navigator's noon changes with his ship's longitude, while land time is based on an arbitrary position within a time zone. These two factors would prevent any uniformity between the two even though both clocks were identical.

It is interesting to note that a theatre at Croydon is using the 24 hour clock for its daily programs. The management says "this has given general satisfaction to our audiences as it excludes any possibility of misunderstanding between the management and the public."

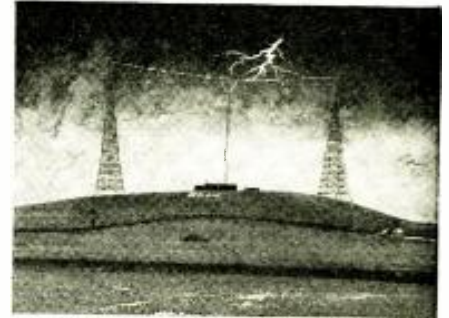

WHAM'S STEEL TOWERS
The 1/4-ton cage aerial which was struck and felled by a charge of lightning.

LIGHTNING STRIKES WHAM

ONE day last month during a heavy electrical storm, lightning struck the antenna of station WHAM near Rochester, New York, and forced it off the air for more than an hour until engineers could rig up a temporary antenna. The appearance of this temporary radiator can be seen from the sketch on this page. More than a quarter of a ton of aerial wire, insulators, and cables crashed to the ground when a lightning charge struck the center of a large cage aerial and shattered the insulators which suspended it.

The lightning hit the station at 11:30 A.M. and for almost an hour after engineers connected with the station under Chief Operator Alfred Balling worked feverishly in an attempt to get the station back on the air for the usual afternoon and evening programs.

After the sign-off announcement, however, their real task began. Working in the glare of powerful spotlights the temporary radiating system was removed and the two 225 foot radio towers were scaled to restore the station to full efficiency. Two hours of constant work at a hand winch were required to

IN REVIEW

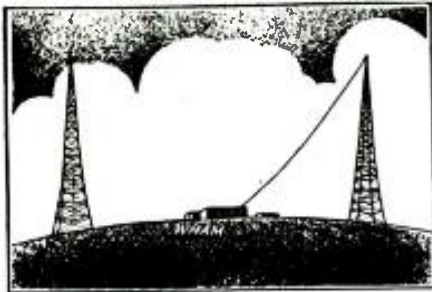

WHAM'S TEMPORARY AERIAL
Rigged up to keep the station on the air during an emergency—recently.

raise the cables to their proper height. Mr. Balling explained that the towers tend to protect the surrounding country from electrical storms by attracting and dissipating the high potentials that build up during severe storms. The transmitter has been struck frequently, he said, but without such severe consequences.

FORD LOSES LICENSES

THE Ford Motor Company which has been operating three radio stations in Michigan was denied a renewal for the licenses covering these stations, by the Federal Radio Commission, last month.

The stations are WBXC and W8XE at Dearborn and W9XH at Lansing. W8XE is a radio telephone station and the others are aircraft beacon stations, all originally licensed for experimental work in the aid of air navigation.

Examiner Ralph L. Walker of the FRC in his report last month made the following statements. "The frequency 410 kc., 21 kc., removed from the operating assignment of station W8XE is used for distress traffic on the Great Lakes. Radio-equipped vessels operating on the Great Lakes are required to maintain a watch on the distress frequency. The receiving equipment of these vessels, some 200 in number, is not capable of sharp tuning, nor is such tuning desirable in view of the probability that an operator sending distress messages will not have his transmitter tuned exactly to 410 kc.

"The operation of W8XE results in blanketing the distress frequency. While it is true that W8XE operates only 6 minutes of each hour, it is true that the effectiveness of the distress watch will depend on the ability to receive distress traffic continuously. Nat-

urally, a 6 minute delay may have serious consequences."

Of the other two stations W9XH is not now in use. The only experimental work being carried on the W8XC is tests of the durability of the equipment in use, and no changes have been made in this equipment during the last license period.

Officials of the FRC said that recommendation for renewal of licenses had no connection with Henry Ford's failure to uphold the NRA, a speculation advanced from some quarters.

50 KW. FOR STATION KOA



STATION KOA
A newly finished ultra-modern transmitter at Denver, Colorado.

A NEW broadcast station of 50 kw. output was officially inaugurated in Denver, Colorado, last month. This station replaces the old 12½ kw. transmitter of station KOA, the NBC outlet in this city.

In construction, it represents the most modern achievements in the radio and architectural arts. The entire transmitter is housed in a most up-to-date one story building which boasts of a guests' lounge, and separate rooms for the transmitting equipment and the speech input amplifiers and mixers.

A 470 foot tower comprised the half-wave antenna system which is coupled through the transmitter through a transmission system correctly matched at both ends. While the output of this transmitter is not excessively high, it is expected that the coverage will be much greater than previous transmitters of this size due to the modern engineering methods employed.

An important factor in determining the most desirable location for the station was the taking of careful field-

Radio is now such a vast and diversified art it becomes necessary to make a general survey of important monthly developments. RADIO-CRAFT analyzes these developments and presents a review of those items which interest all.

strength measurements in order to secure maximum coverage with minimum power.

RMA RECEIVER DESIGNATIONS

THE engineering section of the Radio Manufacturers Association has been at work for quite a few years trying to standardize the radio industry in order that it may be put on a firm foundation. Included in the many parts of the standardization work has been the task of defining receivers according to their frequency range, or in other words under the various classifications which these types of receivers follow.

Last month the RMA found it necessary to make a change in the definitions covering broadcast receivers and from now on the following designations are correct.

1—The "standard broadcast" receiver having a frequency range from 540 to 1570 kilocycles (555.2 to 191.0 meters) to include the recent extension of the broadcast band. The frequencies between 1500 and 1570 are at present being licensed for experimental "high fidelity" transmission.

2—The "all-wave" receiver, having a frequency from 540 to at least 18,000 kilocycles (555.2 to 16.6 meters).

3—The "standard and short-wave" receiver having frequencies between 4000 and 20,000 kilocycles (74.9 to 14.9 meters).

The term "dual waves" has been eliminated by the RMA as an alternative definition for the "standard and short-wave" receiving set having a frequency range between 4000 and 20,000 kilocycles. RADIO-CRAFT will use these terms in defining receivers in all future issues.

NEW RECEIVER DESIGNATIONS
The frequency ranges of the three types of broadcast sets as designated by RMA.

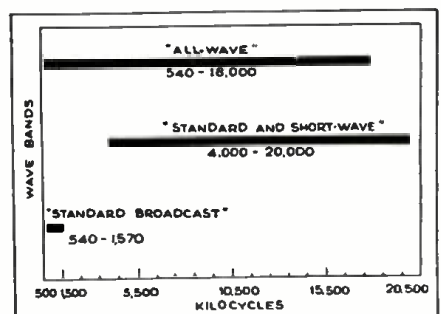

RADIO PICTORIAL

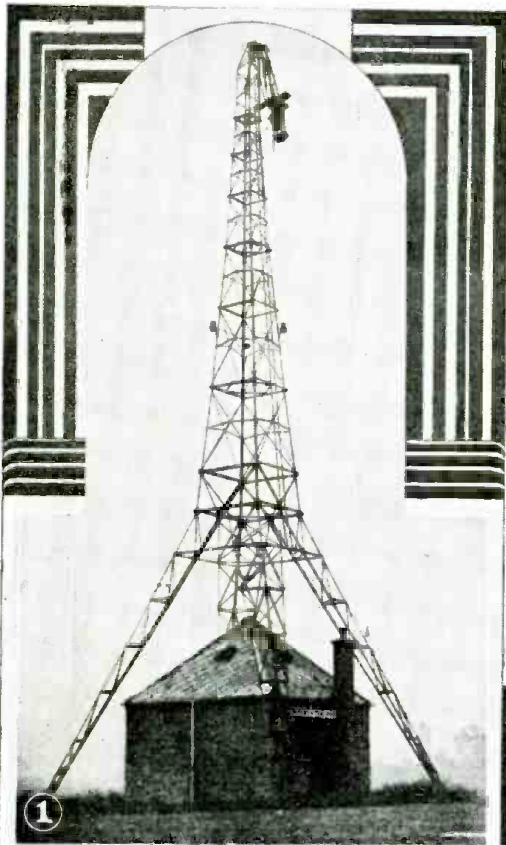

TWO MEN were killed, four houses were badly damaged and two garages (each containing a car) were completely wrecked when a French freight plane crashed into one of the radio towers at Croydon, England, a short time ago. The appearance of the radio tower after the crash is shown at 1. If accidents of this sort persist, some means of protecting antenna structures and nomadic aviators will have to be taken.—
WHEN the President goes vacationing great pains are taken to see that he is provided with all possible comforts, including a means of obtaining the latest news via a radio set. In Photo 2 is shown a view of the combination sitting-reading and radio room which was recently prepared aboard the U.S.S. Houston in Brooklyn Navy Yard for the use of President Roosevelt during his vacation cruise to Hawaii.—
PUBLIC address installations have even invaded the navy as illustrated by the photo at 3. This photo shows Rear Admiral Henry V. Butler (in front of the amplifier and microphone), addressing officers and crew lined up on the flight deck of the U.S.S. Saratoga during the picturesque change-of-command ceremony in New York last month.—
RADIO has performed many humanitarian acts such as rescues at sea, communication over flooded areas, guiding the blind, etc., but it becomes more and more evident as time goes on that there is no limit to the number of useful applications to which radio devices and systems may be put. The photos at 4 and 5 illustrate a device which has been developed by Dr. Robert H. Gault of Northwestern University. This device transforms sound vibrations into strong mechanical vibrations which can be felt by the finger tips and, with practice, identified by those unfortunates who have been deprived of their hearing. The device consists of a microphone or phonograph pickup connected to a suitable vacuum tube amplifier and a translating device or a vibrator unit which is touched by the deaf person. The latter unit, called the Teletactor, is made in two forms—a magnetic type and a condenser type. The magnetic type consists of a specially made magnetic speaker unit with an aluminum plate attached to the diaphragm. The condenser unit is made of two plates cut from Rochelle salt crystals and is similar to piezo-electric speakers.

Photo courtesies: 1, 2 and 3, Press Photos; 4 and 5, Dr. Robert H. Gault.

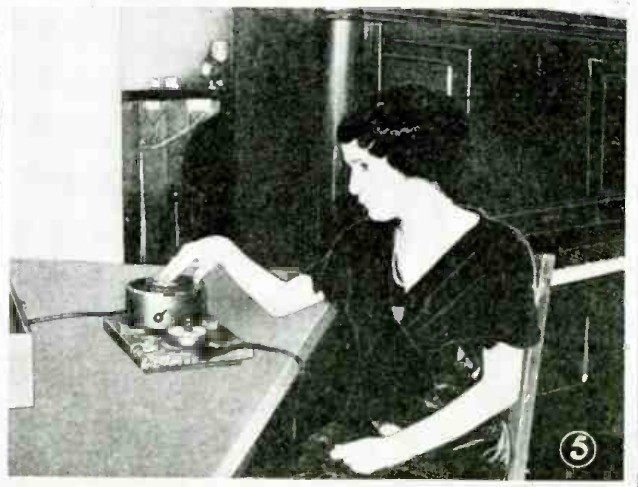
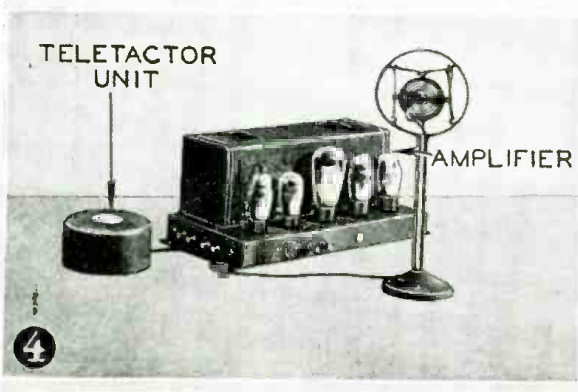

RAILROADS are becoming more and more appreciative of the advantages derived from the use of electronic devices. In the July issue of RADIO-CRAFT several views were shown of the new Zephyr train in which a complete radio receiving installation was included. The BMT Subway Line of New York City, not to be outdone by the Chicago, Burlington & Quincy Railroad, has just put into service a new modernistic train which is completely controlled by the motorman. To facilitate turning the lights on and off when the train goes underground and on elevated structures, a photo-cell device is installed in the motorman's compartment. This device which operates from the degree of light intensity in the motorman's booth turns on the lights in the entire train when the light value falls below a certain level.—RADIO listeners in England are charged a tax for operating their radio receivers and periodically John Bull's special radio detection "vans" set out to collect some of the delinquents or radio pirates as they are called on the other side of the Atlantic. The photo at 7 shows two of these cars ready to start out on their anti-pirating mission.—THAT original ideas always reap profits is aptly proven by a store in New York City which, through the medium of the home-made singing robot shown at 8, has greatly improved business. The store handles sheet metal materials such as stove pipes, funnels, etc., and the proprietor assembled the "man" entirely from these simple parts. Two loudspeakers are installed in his arms with cables running down through his legs to the store below, where a radio set and amplifier give him his voice.—AS a means of testing the life of their auto radio sets under driving conditions, a well known manufacturer has installed the device shown at 9. This unit, which vibrates the set at varying speeds up to 3425 times per minute, subjects it within five hours to an equivalent abuse that may be received in over 30,000 miles of driving. During this period the set is jiggled up and down 1,027,500 times.—AT 10 is shown a view of one of the tents in a camp set up by German youths, in Tempelhof, near Berlin. It will be noted that the equipment in this tent includes both electrical phonograph and radio equipment.

Photo courtesies: 6 and 8, Halbran; 7 and 10, Press Photos; 9, Emerson.



PHOTO-CELL UNIT



DIRECTION FINDERS

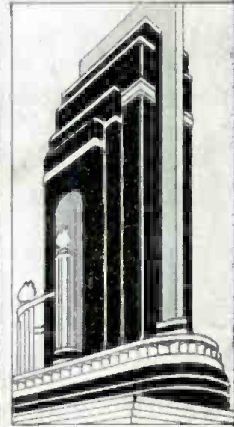
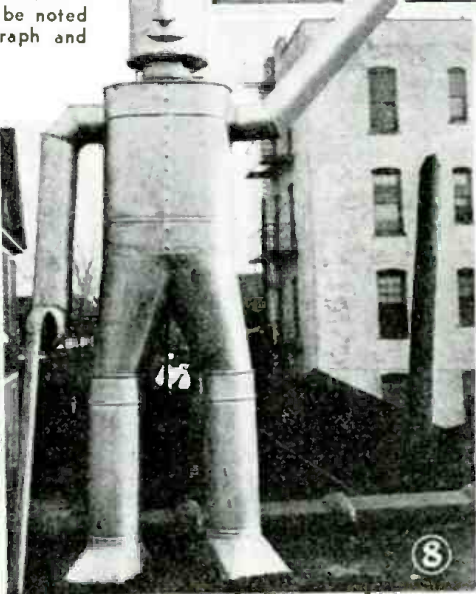

AUTO-RADIO SET

VIBRATING PLATFORM

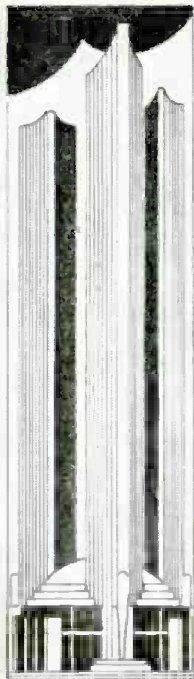

THE LATEST RADIO EQUIPMENT



Marine radio set. (No. 520)

MARINE-TYPE 6 OR 32 V. PORTABLE (No. 520)

A MARINE superhet. is now available. It weighs only 14 lbs. Its dimension are: $9\frac{1}{2} \times 12 \times 6$ ins. deep. The set is specially designed for use aboard small boats where either 6 V. or 32 V. is available.

A small motor-generator for supplying 250 V. to the plates of the tubes is built in as an integral part of the complete portable receiver.

TIME-DELAY ON-OFF SWITCH (No. 521)

DELAYED operation of radio and electrical apparatus is often very desirable. The latest and most compact unit for this service makes it convenient to turn off any piece of apparatus at any pre-determined time, merely by twisting the handle to the graduation indicating, to the quarter-hour, the "off" time.

The bakelite case measures only $1\frac{1}{4} \times 3$ ins. in diameter.



Time on-off switch. (No. 521)

ELECTROMAGNETIC RECORDERS (No. 522)

A POWERFUL electromagnetic field, much stronger than could be obtained from permanent magnets, is secured by the use of a 6 V. field coil, in the newest cutting-head designed for high-quality home-recording. A balanced armature is used. Its four actuating coils are wound for connection to a transformer secondary of 15, 50, 200 or 400 ohms, as specified.

Needle pressure is adjustable from 2 to 12 ozs.; arm is rigid cast aluminum; bearings are adjustable pivot type. Designed for operation in conjunction with a leading screw (Item No. 368, "Phonograph Cutting Device," RADIO-CRAFT, January 1931, pg. 394).



Recording unit. (No. 522)

ILLUMINATED TEST PRODS (No. 523)

MODERN radio sets often present a maze of wires, in assorted colors, that it is difficult to check through without adequate lighting at the point of test.



Above, lighted prods. (No. 523)

Below, dual-wave set. (No. 524)



To meet this demand there has been developed an illuminated test prod. Although shown in connection with the manufacturer's "de luxe" prods, the lamp clips onto any prod at any point along its length. A single dry cell in a case lights the bulb.

A.C.-D.C. DUAL-WAVE RECEIVER (No. 524)

A NEW 6-tube ultra-midget superhet. is available in 2 models: one type covers a range of 15 to 50 and 200 to 550, meters, and the other, 200 to 600, and 800 to 2,000. Utilizes 2 6D6s, 1 6A7, 1 75, 1 43, and a 25Z5. The circuit incorporates A.V.C. and tone control. Both tuning dials are illuminated; a $6\frac{1}{2}$ in. dynamic reproducer is used. The set weighs only 12 lbs. An adapter for 220 or 240 V., A.C.-D.C. operation is available.

The "wise" radio man will be interested to know that a stage of tuned R.F. amplification precedes the first-detector.

COUNTER AND PORTABLE TUBE TESTER (No. 525)

TEST equipment has made great advances, as the latest instrument design indicates.

This piece of radio servicing apparatus tests the mutual conductance of tubes, but expresses the efficiency in direct, English-reading terms of "good," or "poor." The tester is designed to check the efficiency of all standard, as well as special and obsolete types, including multi-purpose designs, and the plates of rectifiers of all types. A self-contained $\frac{1}{4}$ (not furnished) supplies D.C. for test purposes.

The cast-aluminum case measures $11\frac{1}{2} \times 7\frac{1}{2} \times 5$ ins. high.

AN A.C.-D.C. POWER CORD (No. 526)

WHEN the limiting resistor in an ultra-midget set "goes West," or electrolytic condensers become defective because of excessive heat inside the chassis, replace the resistor with a "power cord" or

3 conductor cable, one conductor of which has a resistance equivalent to that of the built-in resistor. One type available is 6 ft. long and is made in 3 types: No. 8920, 135 ohms, filament drop 25.2 to 31.5 V.; No. 8921, 165 ohms, fil. drop 56.5 to 68.9 V.; No. 8922, 290 ohms, fil. drop 68.9 to 75.2 V. One end of the cord terminates in a midget-type, unbreakable rubber plug.

PORTABLE ALL-WAVE A.C. SET (No. 527)

ANNOUNCED as the first of its type, the latest 6-tube portable superheterodyne now makes all-wave reception available anywhere that a power supply of 110 V., A.C., is to be found.

Wavelength ranges (switch controlled): 15-35, 30-85, 80-210 and 200-560 meters. The tubes: 1 6D6, 2 7bs, 1 77, 1 42, and 1 80. Power output, 3 W. Measures $8 \times 12 \times 6$ ins. deep; weight, 12 lbs. Provided with a fabrikoid-covered, drop-front carrying case. Incorporates tone control and a 5 in. dynamic reproducer.

A GROUND-WIRE ANTENNA (No. 528)

IN INSTANCES where the erection of a regular antenna or even a light-line connection (through a condenser) cannot be made, good results can often be secured by using only the ground wire.

A novel unit has been designed which incorporates a bank of condensers so connected as to permit the signal pick-up of the ground wire to be utilized at the antenna post of any radio set in the most efficient manner.

The unit is housed in a japanned metal case.

"BASIC" AMPLIFIER ASSEMBLY (No. 529)

A NEW series of basic P. A. amplifiers has been specifically designed to meet all of the operating requirements commonly encountered in all forms of P.A. applications, whether they be permanent or tem-



Left, newest tube tester. (No. 525)
Right, all-wave portable. (No. 527)
A.C.-D.C. power cord. (No. 526)



RUBBER PLUG



Name of manufacturer of any device will be sent on receipt of a self-addressed, stamped envelope. Kindly give number in description under picture.

porary installations, and mobile or stationary.

This complete series of P.A. amplifiers is essentially composed of a combination high-gain, high-power and high-fidelity amplifier together with a full-fledged input "mixer-fader" control panel. Both units are housed in one compact, black crystalline finished steel case which measures 19x10½x9½ ins. high.

The amplifiers proper are available in various models ranging in A.F. power output from 5 to 100 W. An integral control panel provides complete mixing and fading facilities.

A DUAL-WAVE COIL KIT (No. 530)

ENGINEERING improvements are to be found in all branches of radio. Included in this category are tuning inductances of all types. There is now available a complete kit of high-efficiency coils to meet nearly all requirements. One design incorporates 5 coils for dual-wave reception in a superheterodyne circuit.

The wavelength range is given as approximately 75 to 550 meters, for one coil kit, and 200 to 2,000 for another, using approximately the same circuit; the 175 kc. I.F. coils are shown at B and C. Designed for operation with an oscillator condenser using plates shaped to eliminate the need for a padding circuit.

LAPEL-TYPE VELOCITY "MIKE" (No. 531)

PUBLIC address specialists will be greatly interested in the newest type of lapel microphone, which operates on the velocity principle ("The Velocity Microphone," November 1932, RADIO-CRAFT, pg. 272).

Its outstanding feature is that it is not affected by physical motion of the speaker's chest or from body movements.

The optimum sensitivity lies in the direction of the mouth when the speaker's head is turned to either side away from the microphone. Diffraction of the voice around the head has been compensated. The uniform fidelity rating by the manufacturer is 80 to 7,000 cycles (an excellent rating for this type of instrument).

AUTO-NOISE FILTER KITS (No. 532)

ONE house has now developed a complete line of units for use in eliminating car-radio interference.

The entire series incorporates the following components:

Fixed condensers for bypass work of all kinds; one type is provided with a mounting clip and tipped lead; another is suitable for use where heat and moisture are ex-

cessive; a third is made without mounting clip, but with tipped leads, in single or dual-capacity units.

Filter units are available which incorporate a 5 A. choke coil bypassed at either or both ends.

Suppressors for distributor and spark plugs are made in assorted types. The resistance element is made of "corbite," a material that is formed under tons pressure and fired at high temperature. Housings are available in both bakelite and isolantite.

FLUX-FILLED ALUMINUM SOLDER (No. 533)

WHAT is said to be the first flux-filled aluminum solder has made its appearance on the market, in small tins and spools of 1 lb. size and larger.

In this new solder a metal has been chosen, the solubility of which in aluminum is such that the intermetallic solution necessary in soldering is easily formed. Also, the flux that was chosen enables the soldering operation to be completed with a minimum of oxide formation.

A NEEDLE-POINT TEST PROD (No. 534)

MEN are always interested in good tools, regardless of their type, but radio men, especially, will be interested in the latest development in test prods.

A phonograph needle tips the tapered shank, the other end of which is provided with a clutch for holding the standard phone tip that is usually used with tinsel cord. The case is of bakelite, 5/16-in. in dia.; the total length of the test prod is 5¼ ins.

The needle tip may be replaced in a few seconds by the use of a soldering iron; the cord, by unscrewing the shell. The needle bites through all kinds of insulation, and makes sure contact to the conductor underneath.

ALL-WAVE ANTENNA LEAD-IN (No. 535)

THE inadequacy of "twisted-pair," of the type generally used in telephone work, for balancing out man-made interference picked up by the lead-in portion of all-wave antenna systems has been demonstrated by recent researches.

One manufacturer, in solution of the problem, has evolved one design in a "transposition-cable" lead-in. It consists of 2 stranded, rubber-covered wires, which are twisted, or "transposed" in their relation to each other, every few inches, and served with a weather-proofed braid.

The cable is available in coil lengths of 100 and 500 ft. (The use

of a "transposition-cable" lead-in for all-wave antenna systems is discussed in the article, "All-Wave Antenna Systems," Parts I and II, in the July and August, 1934 issues of RADIO-CRAFT.)

12 TUBE ALL-WAVE SUPER. (No. 536)

ONE manufacturer is concentrating his entire sales energy on a new 12 tube all-wave superheterodyne. A 4 position switch controls the range of 11 to 570 meters. This set incorporates a noise and sensitivity control, electron-coupled beat-frequency oscillator, A.V.C., phonograph connections, meter tuning, manual band spreading, Wunderlich second-detector, and provision for headphone connection. Utilizes 5 type 58 tubes, one 2A7, one Wunderlich, 2 2B6s and 2 5Z3s.

The undistorted output of the push-pull power amplifier is 12 W. The antenna-to-speaker fidelity is rated at 30 to 4,000 cycles, uniform to 10 db. The selectivity immediately adjacent to high-power locals is 9 kc. The sensitivity is ¼-microvolt absolute.

This receiver is composed of 2 chassis. The tuner measures 19½x12x9½ ins. high. The power supply measures 19½x7x8 ins. high. Any unit used in the construction of this set that becomes defective within 2 years will be replaced free of charge either for parts, material or labor.

MIDGET ELECTRIC PLANT (No. 537)

ELECTRIC plants are a lucrative source of income, whether sold outright or on a rental basis, in numerous services, as follows: to operate electric tools, drills, lights on boats, supply power for road camps, bridge crews, oil wells, for oil burners, and emergency lighting equipment in case of power line failure. They will operate electric refrigerators, portable spraying pumps, electric hedge shears, provide lights for summer homes, resorts, dance pavilions, and for sound trucks, flood lights, portable radio transmitters, talking pictures and neon signs.

One commercial unit that meets these requirements has many features to interest the technician and consumer.

This plant is ideal for supplying A.C. power for sound trucks. It can easily be mounted on the rear end of a passenger car or, if installed inside of truck, it occupies very little space. A special, noise-reducing cover and special muffler can be furnished which reduces mechanical noise to a point where it is hardly noticeable. The exhaust is conducted through the base of the plant. This permits the cover to be easily removed by lifting.

(Continued on page 174)



Lapel velocity mike. (No. 531)

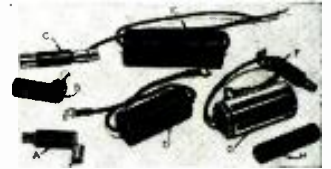

Auto noise filters. (No. 532)



Aluminum solder. (No. 533)

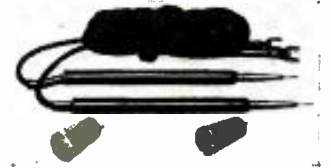

New test prods. (No. 534)



TRANSPPOSED-WIRE LEAD-IN

Above, new lead-in. (No. 535)

Below, all-wave set. (No. 536)

A "ground-wire antenna" unit. (No. 528)



A representative P. A. amplifier. (No. 529)



Dual-wave superheterodyne coil kit. (No. 530)

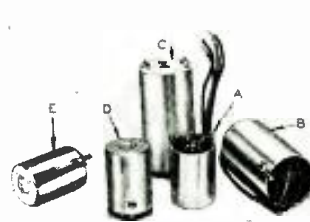

TALK AND LIGHT

Here is a new stunt for the experimenter sending and receiving phone messages by means of a modulated light beam. No need for studying the code, or any necessity for obtaining an amateur license! While this device makes use of radio equipment it does not interfere with broadcasting.

F. R. HARRIS

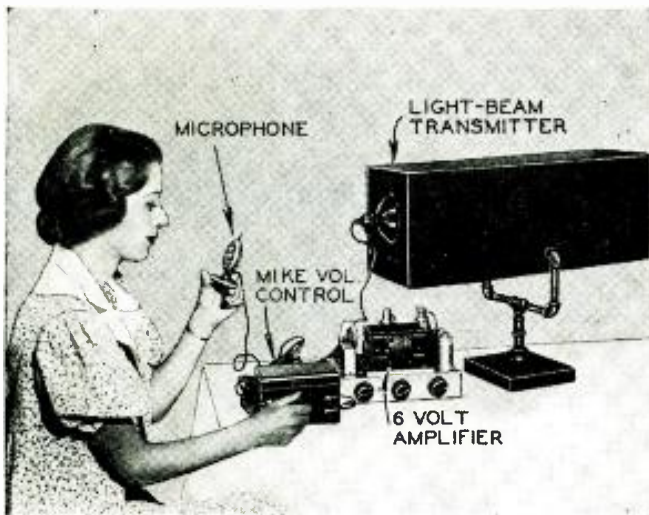

The transmitting equipment.

HAVE a friend who lives in the country; and he has a friend who also lives in the country, some half-mile or so away. Now these two friends pal around together quite a bit, and they are both rabid experimenters in anything electrical. They have played around with almost everything from television on down but somehow or other they have never gone on the air with a transmitter. They are not interested in long-distance transmission of code. About the only thing they would use a transmitter for would be communication between themselves—and going through all the trouble of learning the code and getting a government license just to talk back and forth across a half-mile of territory has always seemed like entirely too much of a job. So they have gotten along by the old method of talking it over in person.

Then one evening we all got together and being radio fans we talked "radio" until the idea of a "talking light beam" struck us. The final result is this article describing the method of getting around all the difficulties connected with code, licenses, or wire lines for point-to-point communication.

The method to be described, that of using a modulated light beam, has a number of advantages. It is somewhat "secret," it requires no elaborate an-

tenna systems, it is perfectly directional, no knowledge of the code is required, and no government supervision is exercised over such communication. The method is reliable over reasonable distances, just how much distance depends largely on how powerful a bulb is used in the transmitter. But the final and deciding argument in favor of it, to any dyed-in-the-wool experimenter, is that it is a comparatively new method and hence a fruitful field for research, particularly in the development of a really good method of modulating a powerful light beam with high-frequency impulses—for with the development of such a method television can be brought to a successful completion.

Construction: The Modulator

While perhaps not the most efficient type of modulator possible, the one used in this set-up has the cardinal virtue of being extremely easy to construct while still being able to do a pretty good job of modulation.

The first job is to cut the cone (of a special midget dynamic speaker) loose at the voice coil. This must be done very carefully with a razor blade or sharp knife, cutting around the voice coil as closely as possible but being very careful that the point of the knife does not

reach the corrugated diaphragm holding the voice coil in place. Then unsolder the voice coil leads from the transformer, loosen the nuts and bolts holding the field "pot" in place and carefully disassemble the entire speaker.

To reassemble, first place in position the pole piece having the round central hole, and accurately center it over the core by using "feelers"; then place a nut and bolt through diagonally opposite corners and draw tight, after which the voice coil assembly is placed in position over these same bolts, carefully centered and held with 2 more nuts. Some form of terminal strip must be made and mounted to anchor the leads going to the voice coil. These details are all clearly shown in the photograph, Fig. A.

The light gate consists of three parts; the vibrating member, 2 pieces of thin, stiff cardboard; 1 a flat gate about $\frac{3}{4}$ -in. high and slightly wider than the voice coil and having 2 little tails cut to fit around the inside of the coil; the other a triangular piece cut and fitted to act as a stiffener for the gate, both being cemented with collodion to the voice coil: the frame member, being a piece of metal cut and bent so as to reach within a very small distance of the gate when supported from the screws holding the field "pot" in place

Fig. A
Photograph of "light gate."



Fig. 1
Constructional details of "gate."

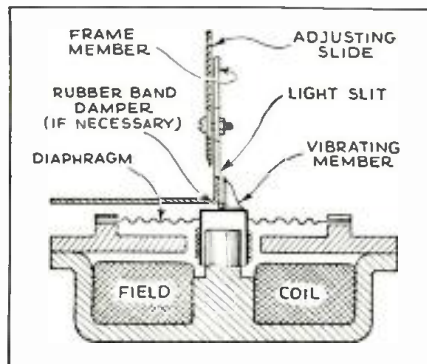
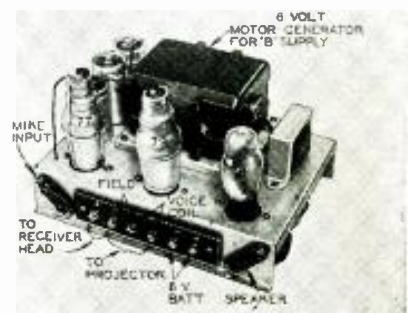

Fig. B
Amplifier uses 6 V. M.-G. for "B" power.



HEAR OVER A BEAM

Amplified speech is employed for modulating a light beam—by the medium of a "light gate" which can be easily built from a small dynamic cone speaker. Both transmitter and receiver are easily built and will give just as much fun to the city fellow as to the suburbanite. What's more, it covers quite a range.



The receiving equipment.

and having a slot slightly narrower than the gate reaching from the top of the frame to below the top of the gate; and the adjusting member, which is simply a flat piece of metal cut and mounted on the frame so that it can be slid up and down to adjust the width of the light slit.

After all these parts are made and assembled the entire modulator unit may be mounted in a block of wood, so arranged that it can be mounted between 2 slotted angles on the baseboard which allow of vertical adjustment of the entire unit.

The Projector

The spot light and the two lenses are now mounted in the exact center of 3 pieces of thin presdwood 7 1/2 ins. square having 2 large, stiff angles on each for mounting to the baseboard. On the back of the spot light mounting place 4 binding posts for the power and voice coil

leads. The baseboard is a piece of heavy board 7 1/2 x 24 ins. long.

After these parts are ready, the spot light is mounted on one end of the plank, a 32 candle power automobile headlamp bulb placed therein, hitched to a storage battery and the bulb carefully focused to give as nearly a parallel beam as possible. Now place one of the condenser lenses on the baseboard, flat side toward the light, and move it back and forth until you obtain a small and bright a spot of light, against a screen held on the other side, as possible. Try varying distances for the screen and light, always maintaining, however, the same distance from lamp filament to lens, and from lens to screen. Fasten the lens firmly in place at the best position found and then mount the light gate exactly at the position occupied by the screen, fastening the slotted angles firmly and then sliding the unit up and down until the top of the gate just cuts the center of the light spot,

and the spot is centered on the slit.

Adjust the sliding member to give a very narrow ribbon of light, then mount the other lens in such a position that a sharp image of the slit is obtained when projected across the room; this is for test work only and will be changed later.

Find the balance point of the plank and mount here by means of pipe straps, 2 short nipples of 3/8-in. pipe which are used as center bearings for swinging
(Continued on page 175)

Fig. 2
Wiring diagram of amplifier and 6 V. motor-generator for "B" power.

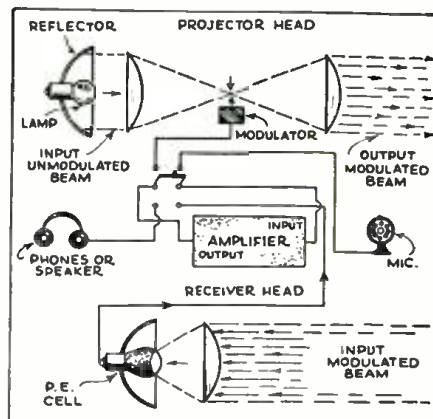
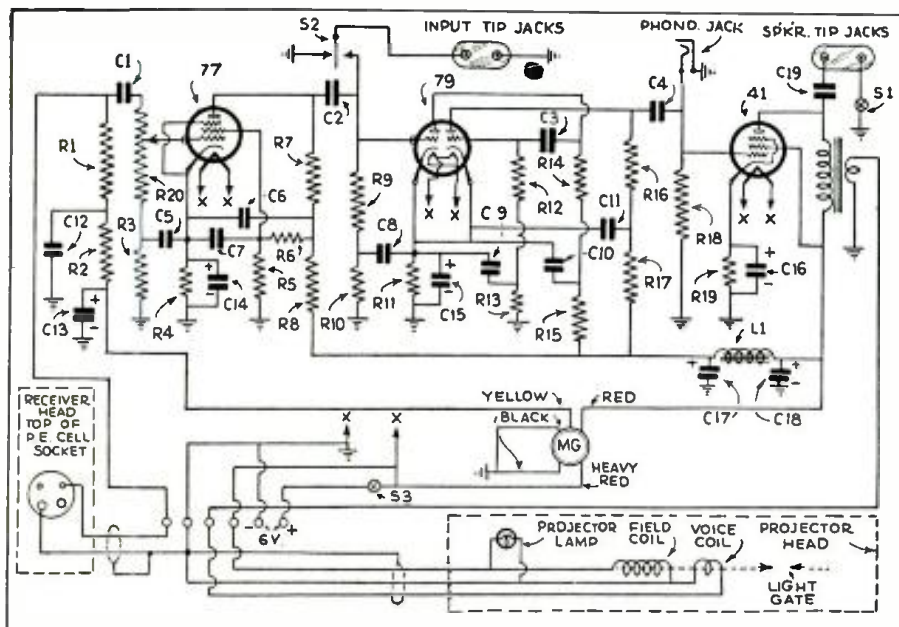
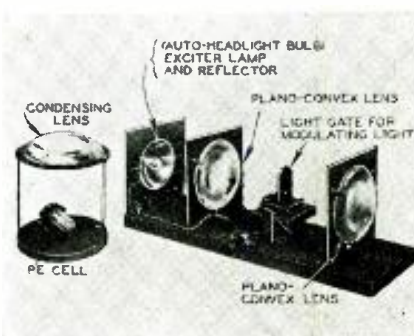
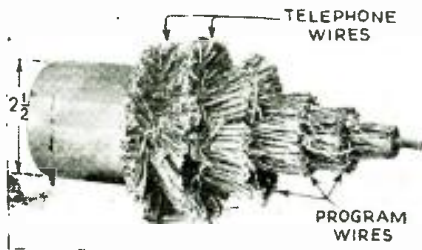

Fig. 3. above.
How system operates, graphically.

Fig. 4. below.
Transmitter and receiver layout.





Cables are the "web" of radio networks.
(Bell Tel. Co.)

THE OPERATION OF BROADCAST NETWORKS

Telephone lines and associated equipment are a most important item in broadcast operation. "Radio" programs often travel 10 times farther by wire than by "air"!

R. D. WASHBURNE



General Control Room, N. Y., supervises the nets.
(Bell Tel. Co.)



Modern studios are veritable super-theatres.
(NBC)

Remote pick-ups announced the arrival of "the fleet."
(CBS)



DOES it ever occur to you that the radio program which you hear may not originate from your favorite local radio station—perhaps 25 or 50 miles away—nor is it a radio broadcast from a station in which the program originates, perhaps 3,000 miles away?

New Yorkers, listening to the President at his desk in Washington, D.C., deliver one of his nation-wide broadcasts, little realize that the voice they hear from, perhaps, their local New York station, WABC, has to travel about 300 miles along special telephone or "program" wires, as they are called, before "going on the air." At the same instant, the program is going out over the network of special program wires that extend 3,000 miles to stations on the West Coast, and via arteries of copper that branch to intermediate broadcast stations in the network system.

If Mr. Jones, listening at his radio set in Los Angeles, let us say, tuned to station KNX in the same city, hears this program with full esthetic value, is the efficiency of transmission to be credited to the broadcast station, which has transmitted the program only a few miles to Mr. Jones' home, or to the telephone or program circuits which, sheathed in lead cables of 200 wires, have carried the program 3,000 miles over mountain and valley, and under river and lake, without losing a single syllable? A review of some of the factors involved in radio network operation may serve to show the importance of this web of highly developed telephone lines which join together in one great family every radio station in the land.

The Purpose of "Networks"

Three major functions are performed by the tentacles of copper that reach to nearly every square foot of the United States.

First, they serve to bring the program from the point of pick-up to a "General Control Office." Second, they carry the program from the General Control Office to all the broadcast stations within a wide area. And, third, they carry monitor messages, conversations, directions and orders over express circuits from pick-up to General Control Office, and to the broadcast stations.

The production of the studio program is another story, and one which has been interestingly told to the readers of *RADIO-CRAFT*, in the article, "From Microphone to Modulator" (January, 1930, issue).

The first "network" dates back to January, 1923, when WEAJ, New York, was tied to WNAC, Boston. The climb to the 11 basic networks that comprise our present broadcast system was an arduous one. Now, the web of this amazing institution consists of 74,000 miles of wire, requiring a maintenance personnel of almost 500 specially trained employees, in order to secure faithful sound transmission and reliable operation at all times. A network of about 50 stations now costs a sponsor approximately \$12,000 per hour!

Fidelity the Foremost Factor

It is little realized that there is one quality above all others which must be kept inviolate by every single device in the entire radio system. We refer to **FIDELITY**; unless the



Honest Service Men are thorough and capable.

BEWARE—THE

This is an expose of the racketeering methods of "gyp" service organizations who advertise free radio service, or 50c inspection service. It is not meant to apply to the Service Men or service organizations who conduct their business on a legitimate basis. As a matter of fact, the honest service individual has recognized the existence of this evil and many have written us complaints concerning these practices, seeking advice to combat them.

By AN ANONYMOUS CONTRIBUTOR

THE radio industry, from manufacturer down to Service Man, today is bemoaning its fate and while the economic depression has no doubt been the major cause of the poor state of the radio industry, I feel that they have themselves to blame to a great extent.

Midget radio receivers had their origin in the plants of small manufacturers and the public at that time did not take them seriously, but considered them novelties or toys. However, when the larger manufacturers followed suit and dignified the midget business by manufacturing such sets themselves, the whole picture was changed. Can you blame the average individual for feeling that sets for \$10.00 are really worthwhile instruments if they possess the trade marks of the largest radio manufacturers in the world? Surely the public has a right to feel that these companies are not manufacturing "junk," and that if they can make a radio set that they are willing to put their name on, to sell for an extremely low price, it is only a waste of money to buy an instrument selling for from five to ten times that price.

While I am primarily concerned with the radio Service Man, I mention the above facts to show that the Service Man has followed the example set by the "brains" of the industry and as a result he now finds himself in a deplorable condition. Just as the larger manufacturers dignified the midget business, so has the Service Man lent dignity to the 50c service proposition.

(Editor's note: This magazine does not entirely agree with the author on this point. The facts of the matter are that there is a place for midget radio receivers, and that a good many homes have such a set to supplement the larger console receiver. This prevents domestic quarrels as to which popular program one may select. The unfortunate part, which the midget is responsible for and which the author fails to mention, is that many manufacturers are listing these sets at a very narrow margin of profit to themselves and to the dealers. In so far as service work is concerned, what chance has a Service Man of honestly estimating a major repair that may total over \$10.00 on a set that is over 2 years old? The customer's retort to such an estimate is

generally to the effect that he can purchase another set, even though a midget, for that price!)

Another problem of the Service Man concerns these sets themselves. Due to their compact construction, and complicated circuits because of the use of so-called "composite" tubes, it is a most difficult type of receiver to service. An investment in elaborate test equipment and up-to-date service manuals is required, in addition to continuous study of new circuits, tubes, theory, etc.—if the Service Man is to be successful in servicing this type and the larger new receivers that are being manufactured. How can the Service Man obtain a fair return for this investment of time and money, when he must spend hours to repair a midget receiver that must be, of necessity, estimated low, since a similar new set can be purchased for a paltry few dollars?

When a customer sees an advertisement of an apparently large, reputable organization offering free radio service, or for 50c (so-called "inspection" service), there is no reason why he should not feel that it is a legitimate charge for honest, efficient service. However, we all know that this is ridiculous and that the only way such an organization can survive is by using racketeer methods.

Everyone connected with the industry knows that the game is to take the receiver to the shop regardless of what may or may not be wrong and to then notify the customer that the set needs a new power transformer or some other part and that the charges are \$15.00 or \$20.00. The only trouble with the set might have been, if a D.C. set, a reversed plug, or in some other set—a bad tube.

(Editor's note: This is only a small sample of some of the practices of "gyp" Service Men. Some even go so far as to resell the tubes [which are still good, but nevertheless used] which they have replaced on previous service calls. Others resort to the nefarious practice



Fig. A, above.
The "racketeer" first removes the set.

Fig. B, below.
Then phones back the exorbitant charge.
Try to get the set back in good shape!



SERVICE GYP!

The honest Service Man who does his work well and expects a fair return for his labor, is in no position to combat the "gyp" who offers free service, with the evident intention of later making an exorbitant service charge. Not unless he stoops to the same practice to cope with this competition! Fortunately, action is being urged against such practices, and we know of no better way to rid this industry of such parasites than by exposing their methods.

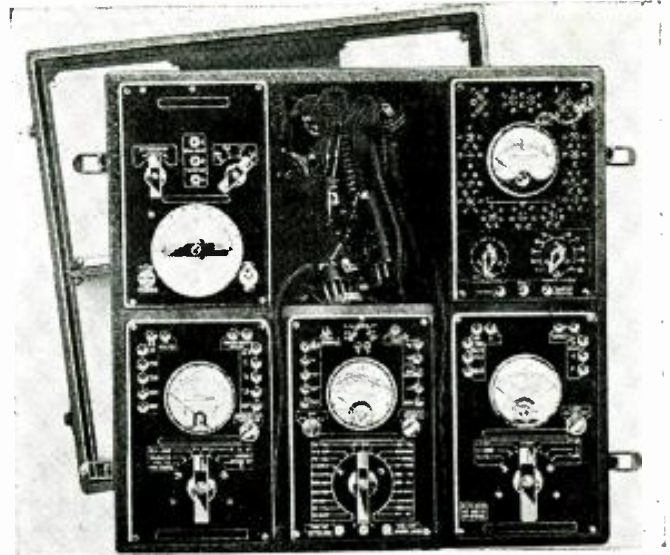

Such men are equipped with all test instruments.

of actually creating additional trouble in a radio receiver when a customer refuses to have the set "repaired" when the exorbitant estimate is learned.

Personally, we believe that the majority of *individual Service Men* are honest. The service organization that advertises or claims free service or service for 50c is the outfit that the consumer should beware of.)

While we all know that ethics in all lines of business are subject to great debate when measured against ideals of strict honesty, the practices in the radio service industry cannot be justified except by comparing them with methods used by racketeers operating outside the law. The Better Business Bureaus have had many complaints from consumers who have been fleeced by the radio service racketeers and, while they have done much good in their attempts to protect the public, their power is limited unless they are willing to actually bring the culprit to court. This involves the expenditure of money besides requiring detailed proof that the power transformer or other parts were not supplied or not needed, and very few persons desire to make martyrs of themselves and testify to that effect. Besides it is rather difficult to sometimes prove the truth, especially in a court of justice where cases are judged on technical details. As a result the service racketeers are permitted to continue in their illicit practices.

As an indication of the "racket" methods and inconsistencies of the "gyp" Service Man, herewith is a reprint from a bulletin published by the Kansas City Better Business Bureau.

"Complaints regarding the servicing and charge of certain radio repair men several months ago led to an investigation by the Better Business Bureau which, thus far, has brought one radio Service Man before the prosecuting attorney's office, eliminated 'free estimate' advertising, stopped a number of 'gyp' repair men and practically cleared the radio repair field of unfair practices.

"Approximately 400 radio service advertisements were stopped. The majority were those offering free radio inspection as in the following:

EXPERT Radio Repairing; guaranteed; all makes; Free Estimates in your home; any time; anywhere; lowest prices. Call . . .

"Complaints indicated that the set owner, lured by the free inspection offer, called in the man offering this type of service. If of the 'gyp' type the repair man sometimes insisted upon taking the chassis to his shop for a check-up. Later he called stating the set needed extensive repairs and often charged exorbitant prices for alleged repairs which actually were not made.

The "Free Inspection" Plan Unfair

"The 'free inspection' plan thrived due to the set owner's misconception of the cost factors involved in radio repair work. Contrary to popular opinion, the Service Man derives most of his profit from his labor. For this reason the legitimate radio Service Man makes a specified fixed charge for a call and a standard charge for various service operations.

"The Bureau felt this 'free inspection' plan to be one of the trade evils having the tendency to break down public confidence in all radio service advertising and evolved a plan to check both the 'free inspection' advertisers as well as those having a call charge.

A Radio Set is "Prepared"

"Accordingly, a popular make radio set was tested, equipped with new tubes, passed upon as being in efficient working condition by a committee of seven expert radio technicians and set up in the home of a person cooperating with the Bureau. A lead wire to the speaker voice coil was disconnected, thus making the speaker 'dead,' and various radio repair concerns were called to

service the set and estimate the cost of repairing it to insure satisfactory reception.

"Following each inspection and estimate, the set was checked by the committee before the next Service Man (Continued on page 173)



Fig. C, above.
Honest Service Men estimate at homes.

Fig. D, below.
Auto-radio men are victims of m'frs' sales "racket," re.— free installation.



INTERNATIONAL RADIO REVIEW

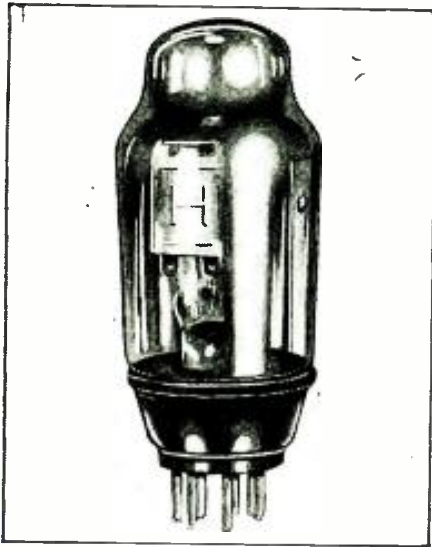

FIG. A
The English duo-pentode tube.

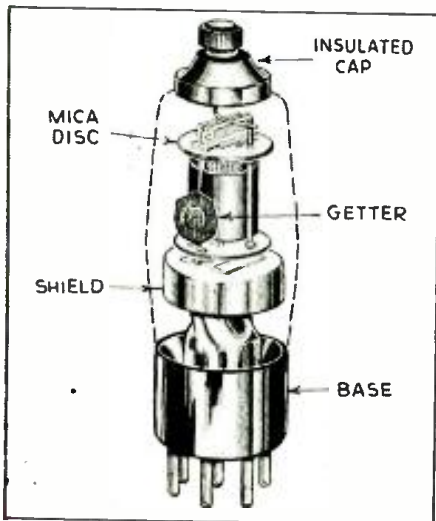

Fig. B
Compare this tube with American types.

HERE is what the radio experimenter has been wanting for a long time—a semi-technical review of the thousands of new ideas which are continually appearing in overseas publications. Each month there are received at the offices of RADIO-CRAFT hundreds of daily, weekly and monthly magazines originating from all over the world.

SINCE the cost of subscribing to each of these would be prohibitive for most radio men, we have arranged with technical translators to prepare for our readers reviews of all the really important, new developments illustrated and described each month in these publications.

NOTE that the only available information is that which is published; the experimenter must adapt the ideas to whatever equipment he has on hand.

A NEW DOUBLE-PURPOSE TUBE

WHILE the manufacturers of radio tubes in this country have declared a moratorium on new tube types for some months to come, the manufacturers in Europe have not limited their developments, and month by month we find new tubes making their appearance on the foreign markets.

In Fig. A is shown a peculiarly shaped tube which has just made its appearance. This tube was described in a recent issue of WIRELESS WORLD magazine.

It is a double pentode output tube rated to give an output of 1.4 watts with a plate voltage of 150. This is considerably higher than previous battery pentode tubes available on the English market, especially when it is considered that this output is obtained

with a grid swing of only fourteen volts.

In the description of the tube, some interesting facts concerning oscillation suppression were given and they are repeated here for the benefit of our readers. "Instability in an output pentode circuit using this new tube gave actual warning by a high pitched whistle. In the case when the oscillations are above the audible range, poor quality and unduly high plate current will, in most cases, be an almost certain indication of their presence.

"The .25-megohm resistor connected between the center tap of the transformer secondary and the 'C' battery was found efficacious in reducing oscillations. The makers recommend joining a resistance of between 5000 and 10,000 ohms in series with the auxiliary grid supply which might be adopted as further precaution.

"An output filter consisting of a 10,000 ohm resistance and a condenser of between .005 and .01 mf. across the tube plates can be used as a tone control although this was found unnecessary as the quality was particularly good with an output transformer ratio to suit the loudspeaker in use."

TUBE MANUFACTURING DETAILS

TUBES of the screen-grid and pentode varieties which have connections at the top of the glass envelope are manufactured differently in Europe than in this country. Instead of having a metal cap cemented to the glass as found in our tubes (such as the 6A7, 58, etc.), an insulating cap with a screw type terminal is cemented to the top of the bulb. In the editor's opinion this is a decided improvement over the American method as many Service Men know the ease with which the control-grid caps may be pulled from the American tubes, generally accomplished by trying to remove the grid cap from the top contact, or when removing the tube from its



Fig. C. Left
A Marconi engineer testing the new police radio installation.

Fig. 1. Below
Three methods for constructing a novel dynamic speaker.

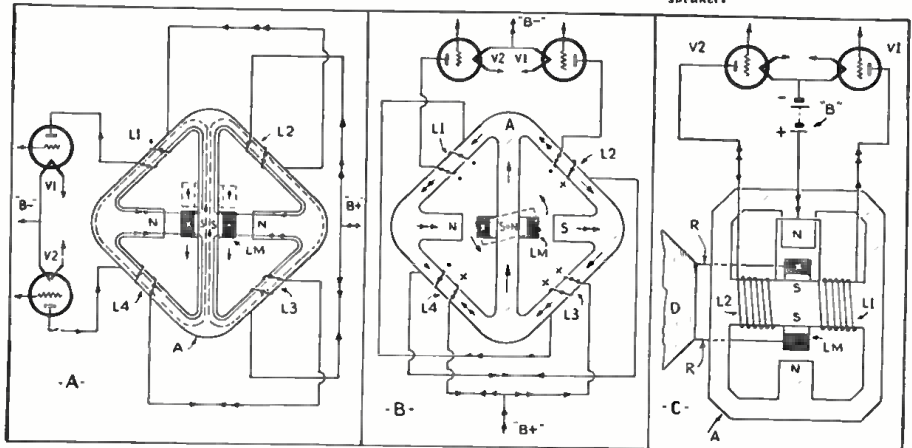

socket. With the type shown in Fig. B a much larger surface is presented between the cap and the glass bulb which reduces the possibility of the two being separated. In addition, the grid contact is made by the use of a lug to the screw terminal, and in order to remove this wire it is not necessary to pull up on the tube as in the American types.

The particular tube shown in Fig. C has several other features which should be of interest to American readers. It is an R.F. pentode with a duo-diode rectifier within the same glass envelope. In order to separate the pentode from the diode rectifier section, a "cap" shaped shield is located at the bottom of the pentode plate. This is clearly shown in the illustration. The cathode extends down through this shield and is surrounded by the two small plates which make up the diode section. The tube is A.C. operated, having a filament designed for operation from a step-down transformer. The pentode section is of the variable mu type which permits the use of A.V.C. in the R.F. or I.F. amplifier.

ENGLISH POLICE RADIO EQUIPMENT

IN FIG. C is shown a new type of police radio installation developed by the Marconiphone Co., which comprises both transmitting and receiving equipment, the transmitter being a radio telephone which permits direct voice connection with headquarters. The receiver can be seen to the left of the regular dashboard instruments of the car, while the transmitter is located below it. On the receiver panel are located the control switches as well as tuning adjustments for both the receiver and transmitter. It will be noticed that the vertical pole type of aerial is installed. This aerial is used for both transmitting and receiving on the short wavelengths covered by this transmitter and receiver. The illustration shows a Marconi engineer testing one of the installations made for the police department.

A NEW TYPE SPEAKER

THE usual driving systems for dynamic speakers have certain faults which become particularly disturbing when these speakers are used for high power. The first of these faults is the

distortion of signals due to the non-linear magnetic field in which the voice coil moves. The intensity of the magnetic field in the air gap in which the coil moves is greater at the inner end of the coil's excursion than outer end.

The second important fault lies in the flexible leads from the coupling transformer to the moving coil which are often the cause of service interruptions.

Figures 1A and 1B show the principle of operation of a new system which recently appeared in *Radio Amateur* magazine. Four coils, L1, L2, L3, and L4, are mounted on a specially shaped iron armature, A, (made of transformer steel laminations) and form together the plate circuit of the output stage of a push-pull amplifier. In other words, a "moving secondary" coupling transformer is the unit of the speaker. This device eliminates the effects of ordinary dynamic speakers, greatly simplifies the construction, and also does away with the necessity for a separate field supply as the plate current to the power tubes automatically excites the core.

The moving coil LM is a closed-circuit inductance placed in the center of the iron core, as shown in Figs. 1A, 1B, and 1C. The double arrow indicators show the directions of the D.C. component of the plate current, which is used for field excitation while the instantaneous directions of the A.C. component are given by the single arrow indicators. The magnetic field of constant intensity connected in the armature by the direct current is shown in Fig. 1A by a continuous line. The dotted line shows the variable magnetic field produced by the A.C. components of the plate current. The variation of the magnetic flux in the central sections of the armature induces in the moving coil an alternating current. The reaction between the magnetic lines of force on the constant field and the induced current of coil LM sets the coil in motion. The motion may be either back or forward like a piston or circular like a motor armature depending on the connections to the four fixed coils.

If it is desired to use only one of the two actions mentioned above, for example, the piston action, the construction can be greatly simplified as shown in Fig. 1C.

(Continued on page 165)

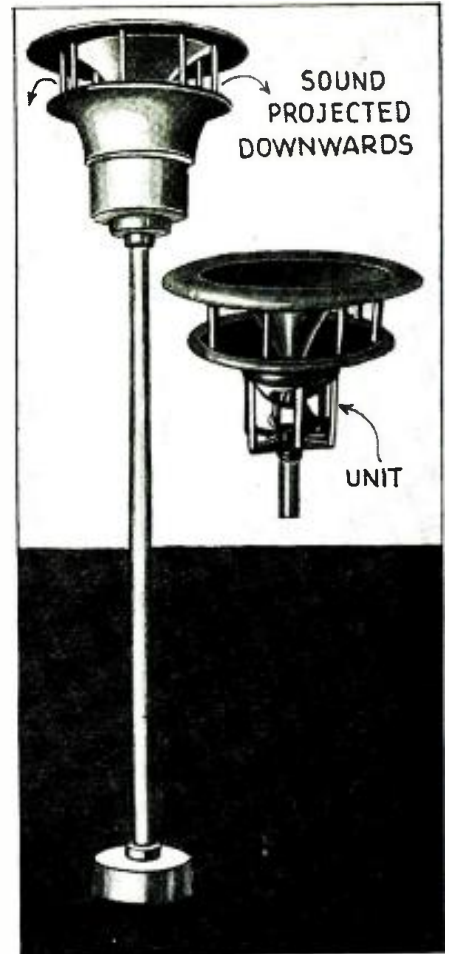

Fig. E
The "mushroom" P. A. Speaker which is a German development.

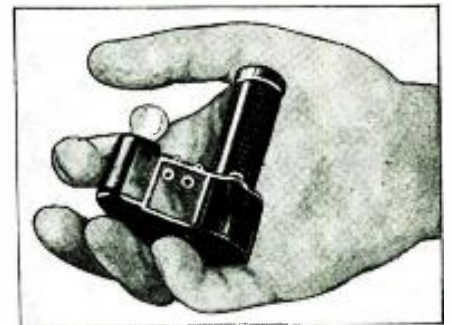

Fig. F, above
The "moving" light-triangle type of visual tuning indicator.

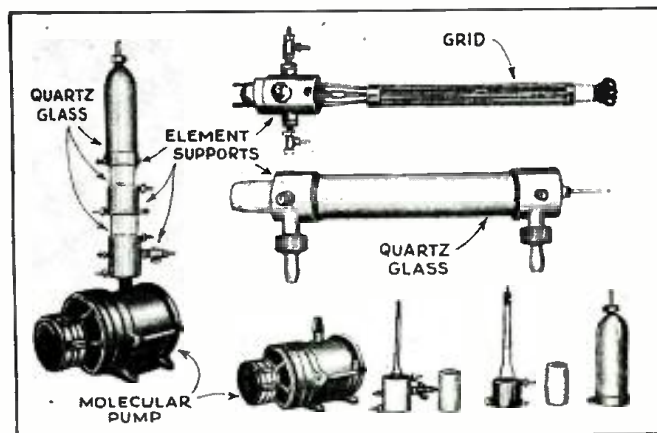

Fig. D
Expensive transmitter tubes can be made to be easily taken apart for repairs by these methods.

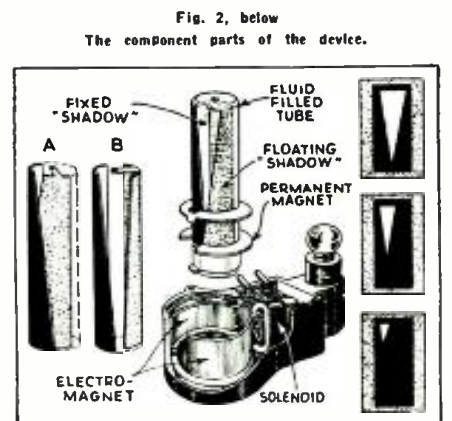
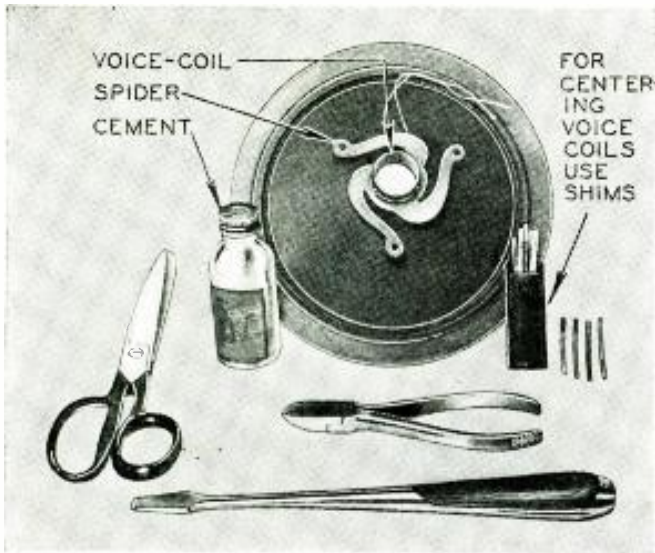

Fig. 2, below
The component parts of the device.

REPAIRING DYNAMIC CONES

Repairing dynamic speaker cones is an art that is only acquired after a great deal of practice and patience. The author describes the procedure, with hints, for locating and repairing speaker troubles.

S. B. VALIULIS*



IT IS the intention of the writer to give a few practical ideas and hints that if followed will lessen the burden of properly repairing or adjusting the dynamic reproducer, and will save the Service Man much time as well as give Mr. Radio Owner better service, and a greater quality of enjoyment from his radio set.

The construction of a dynamic speaker is familiar to every Service Man, and the principle is the same in practically all reproducers of this type. The audible signal is produced by the electrical currents that flow at audio frequency through a voice coil which is fastened to a suspended cone. However, the action will be analyzed further for the benefit of those who are not familiar with dynamic reproducers.

The "cone" is supported at the edge by the "frame" of the speaker, and in many cases is kept aligned to the proper position (exact center) by a flexible support known as the "spider" which is fastened either at the exact center of the cone or around the "voice coil." This will be more clear by reference to C in the figure. (The spider permits movement of the cone in a direction perpendicular to the face of the cone.) At the apex of the cone is the voice coil which travels in an "air-gap" surrounding the round "pole piece" of "an electromagnet." This electromagnet is referred to as the "field coil," and is excited or energized by direct current from an external source.

Around the outside of the field coil is an iron "shell" which fits closely on

the outer surface and serves not only to protect the field coil, but to complete a "magnetic field." Thus, the audio currents which flow through the voice coil make of it an electromagnet, the lines of force of which react against those of the magnetic field in which it is suspended, thus causing movement of the voice coil and consequently of the cone to which it is attached. This results in air vibration and finally the audio sound that we hear.

This type of speaker is the source of most complaints of rattling, harshness, chattering and "fuzzy" reproduction, and sometimes of very weak or no reproduction at all. Let us enumerate a few of the causes of the above symptoms.

Checking the Field Coil

First let us be sure that our field is of proper strength. This is very important and should be checked before work is attempted on the cone. The field can be crudely checked by the pull of the pole piece on an ordinary screwdriver. (Naturally, the set must be turned on so that a magnetic field is created by the current flowing through the field coil.) For accurate results the resistance of the field coil should be measured with an accurate ohmmeter and the results checked with information (usually available in Service Manuals) for the particular set and speaker in question. If the coil is found to be open or partly shorted, it should be either repaired, rewound, or replaced.

On the earlier types of A. C. dynamic reproducers the D. C. field current was supplied from a copper-oxide rectifier unit which changed A. C. to D. C. When these units become old they have a tendency to weaken and must be replaced to secure the proper and original field strength.

If the field is found in good condition your next problem is to check the voice coil and cone of the reproducer. This will be a more delicate job and will require a few ounces of patience and steady hands. Here are a few causes that are probably behind most trouble; some effects:

Sources of Trouble

(1) The voice coil may be open internally or at the flexible leads.

(2) The voice coil may be partially or completely shorted where the ends criss-cross each other.

(3) The voice coil may be off-center and rubbing on the sides of the pole piece.

(a) This may be caused by a warped cone or a warped spider, and sometimes by the voice coil being out of "round."

(4) Rattling may also be caused by a loose seam on the cone, the spider coming loose from the cone where it is cemented, the voice coil wires coming loose from the cone to which they are cemented, or sometimes the voice coil wires coming loose and separating from the thin paper coil support.

(Continued on page 172)

*Engr. General Cement Mfg. Co.

The most common forms of cone speaker troubles are illustrated below. In C is shown how shims facilitate centering voice coils.

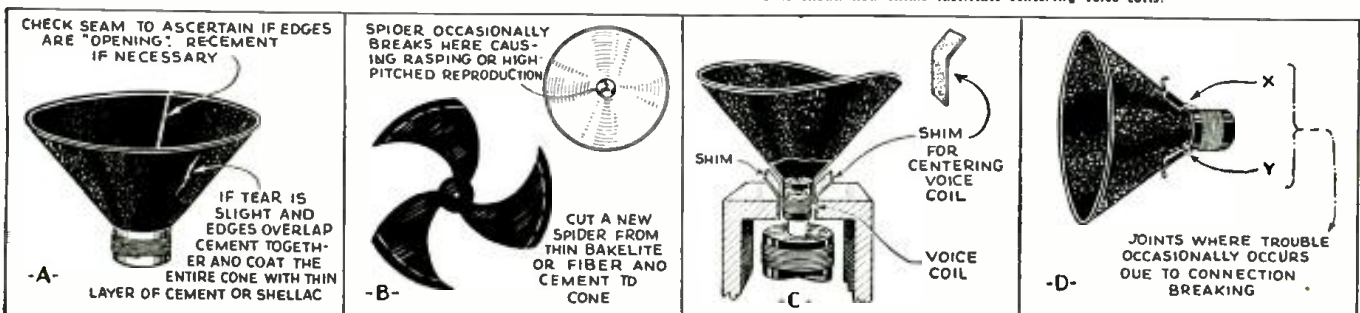

CONVERTING OLD SETS

In last month's RADIO-CRAFT we imparted data on converting electric sets, for Service Men, to bring them up-to-date. In this chapter on "conversion" we deal essentially with methods for making old sets over into "rural" or battery receivers.

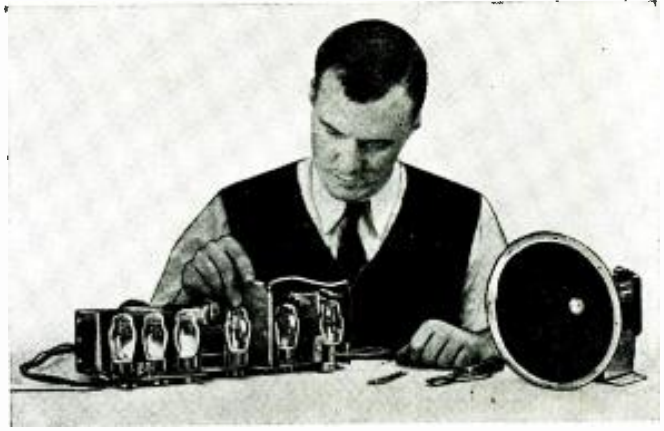

LLOYD MOORE

THERE has been a lot said about how to change the older-type battery sets to use the new 2 V. type tubes. Most articles on this subject have described how to make the change in some particular make of set. This article gives information for changing any type of battery set to use the 30 series tubes. Of course, the finished (rebuilt) set will depend on design and parts used in the original receiver. This along with the results desired and the sum to be spent in the conversion, determine the new design. There are three main types of battery sets now in use, the earlier, unshielded type using triode tubes of the 99 and 01A variety, the shielded type set using triode tubes, and the earlier model battery sets using 22- and 24-type tubes. The hard part of rebuilding these sets is to use the new tubes, get their full gain and still retain stability—in other words, operation without oscillation. It is one thing to merely substitute the new tubes for the old ones and call it a converted set, but it is another thing to actually adapt the set to use the new tubes to their best advantage. This article has been written after rebuilding dozens of old battery sets. It has all been taken from actual practice. The diagrams shown have been used here in the shop many times with excellent results.

The unshielded battery sets can be usually "converted" over to 2 V. operation by substituting the new type tubes and providing the correct "A" voltage. This makes a big reduction in the battery upkeep and at the same time more volume from the weak stations and better tone quality. There is usually no trouble from oscillation in this type of set; however, it does show at times and here is the way to cure it. The procedure comes in order of importance.

First, try placing grounded metal shields at different places in the set. This stops stray fields which cause oscillation. The position in which the shields are to be placed can be determined by using a trial shield about 4 ins. square which is grounded to the set with a flexible wire. This shield is moved about in different positions between the coils and condenser until a place is found where oscillation stops. It may be necessary to use more than one shield to get the desired results. After the correct position has been found the shields are then fastened permanently in place. Do not

(Continued on page 171)

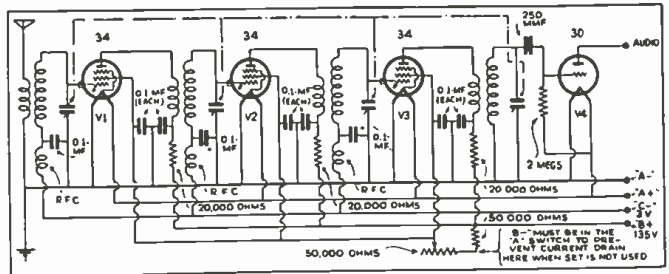

Fig. 2
Changes necessary for dry-cell tube use in tuner section.

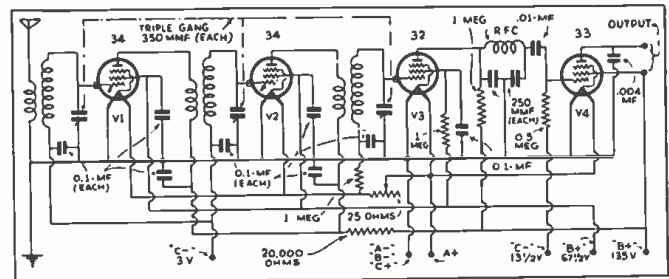

Fig. 3
Complete wiring for "battery tube" type receiver.

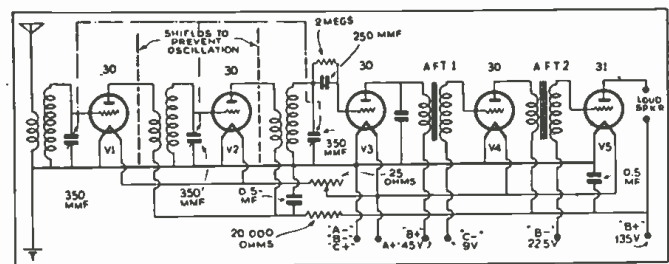

Fig. 4, above
Low battery consumption and upkeep are featured in this set.

Fig. 1
Connections to remember when "converting" battery sets.

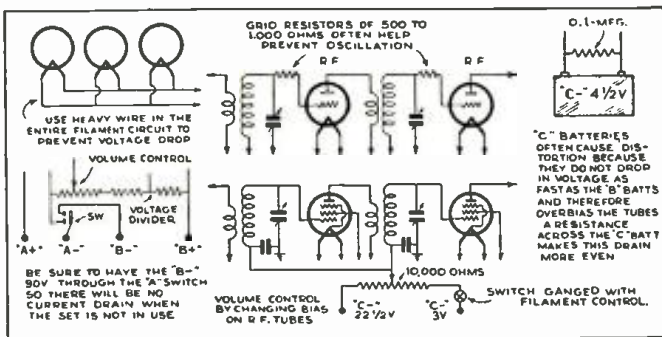

Fig. A, below
Appearance of an A.K. battery set now "up-to-date."



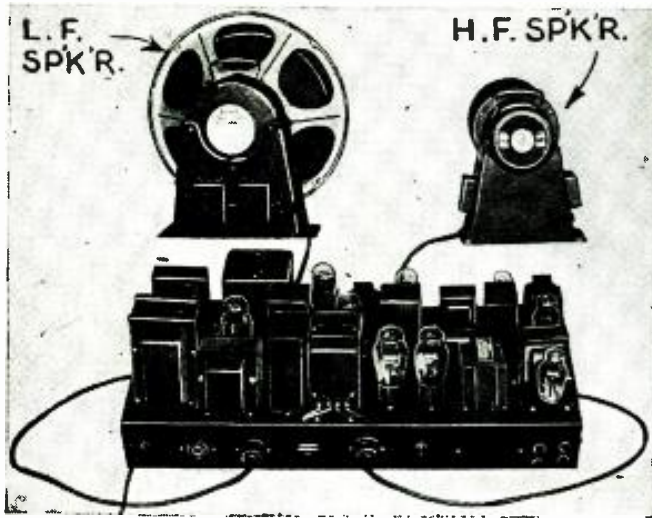

Fig. A
H.F. and L.F. speakers help attain high-fidelity.

A NEW HIGH DUAL-CHANNEL

Here is a most thorough article on high-fidelity reproduction, in which all of the salient essentials to obtain lifelike or natural reproduction are dealt with. All possible angles are discussed not only theoretically but practically as well. In addition, complete constructional details are given for a high-fidelity amplifier system.

MADISON R. JONES, JR.

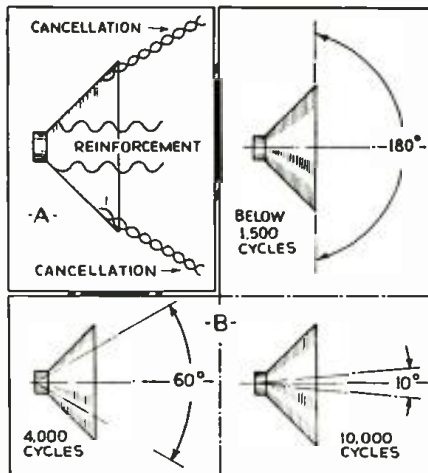

Fig. 1
A—Illustrates how cancellation of sound waves causes "beam effect." B—Typical sound beams from dynamic cone speakers.

HIGH-FIDELITY, or as it is often called, wide-range transmission has been used throughout the country by many of the larger broadcast stations for several years. The field of wide-range reception and reproduction, however, is still in its infancy, although it has been rumored that it will be the main selling point for the new 1935 sets. It is with this fact in mind that the author has designed the amplifier to be described.

In connection with high-fidelity reproduction several things must be considered. First, it is necessary to use loudspeakers which will reproduce the entire frequency range desired, and with equal over-all efficiency. Second, the amplifier itself must be capable of transmitting this same frequency range with as little distortion as possible. Third, in order to obtain the full benefit of a high-fidelity amplifying and reproducing system, the input apparatus, such as a suitable R.F. tuner, phonograph pickup, or microphone, should be capable of passing or producing as wide a range of frequencies as that of the amplifier. In other words, it is impossible to get high-fidelity reproduction with an extremely selective receiver, because a selective tuner attenuates the side-bands which contain all the "highs." Hence, it is necessary to use either a broadly tuned receiver, or else one which is arranged to tune broadly on locals. Only local stations are referred to, because the quality of distant stations at best is not very good.

One other fact must be considered in connection with high-fidelity reproduction. The human ear cannot hear all frequencies with the same degree of intensity at all volume levels (especially the lows and extreme highs at low volumes). Therefore a high-fidelity amplifying and reproducing system, in order to sound as nearly natural as possible—and that is all high-fidelity means—needs more than a "flat" frequency response curve. One must compensate for the missing high and low notes when necessary. This is why many people turn the tone control on their

sets over to "bass" at low volume levels in order to compensate for the lack of lows (but in so doing, they usually are eliminating the highs altogether). These points have all been considered in the design of this amplifier, and as a result it is rather large and somewhat complicated, but the results justify the labor and cost involved.

Low- and High-Frequency Speakers

This amplifier was designed as a dual-channel system in the strict sense of the word for two reasons. First, in order to get good over-all efficiency in the reproducing system, two speakers are required. One, a large dynamic cone type speaker for the lows, and the other a highly efficient dynamic horn speaker of the "tweeter" type for the highs. A high-quality low-frequency speaker must be used, rather than one of the popular "pee-wee" 5, 6 or 8 in. jobs, because the lows in the small speakers are primarily harmonic distortion.

At low frequencies all cone-type dynamic speakers are almost non-directional, but at the higher frequencies (above about 1,500 cycles) they become increasingly directional. Below about 1,500 cycles the diaphragm moves as a whole (a piston) but above that frequency the cone begins to vibrate in parts. The sound waves start at the voice coil and are transmitted through the paper cone toward the outside edge as well as through the air. Now, sound is transmitted more rapidly through paper than through air; as a result the sound waves transmitted from the outside edge of the cone will be out of phase with those transmitted directly to the air by the inside part of the cone (voice coil edge), as shown in Fig. 1A, and cancellation takes place. This causes the so-called "beam" effect which becomes more pronounced as the frequency is increased until at 10,000 cycles the sound beam in a speaker similar to the low-frequency unit used herein subtends a solid angle of about 10°. (5° each side of the axis, as shown in Fig. 1B).



Fig. B
Parts layout of dual-channel amplifier.



Fig. C
Sub-base layout, approximate.

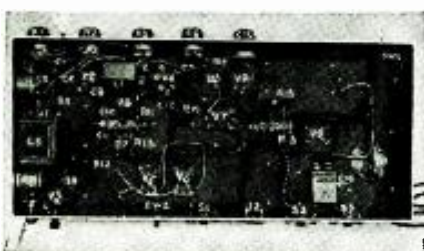

FIDELITY AMPLIFIER

The RMA Engineering Division has recently interpreted, tentatively, "High Fidelity" as applying only to a receiver having an audio frequency range of at least 50 to 7,500 cycles with variations not to exceed 10 db., and with a total output of at least 10 W., total distortion not exceeding 5 per cent.

Note how well the specifications of the amplifier system described here compare with these RMA specifications.

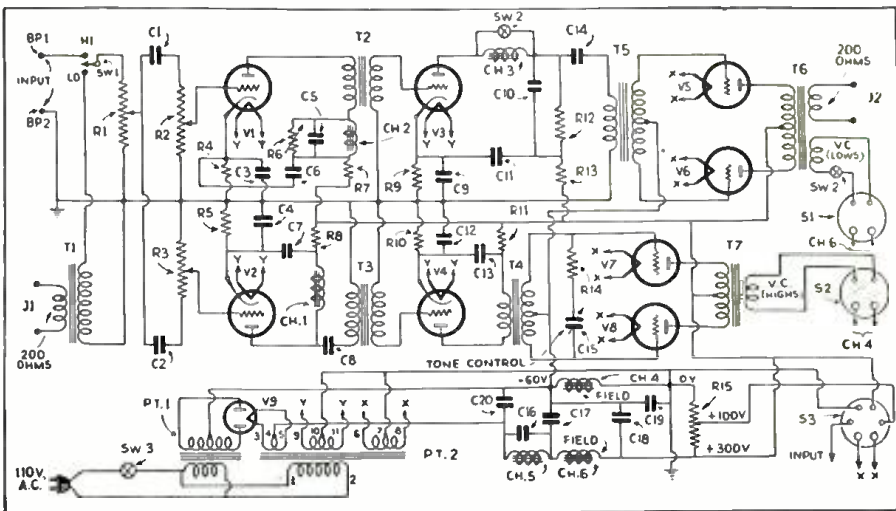

Fig. 2
Wiring diagram of dual-channel amplifier with high-fidelity characteristics.

Determining Speaker Characteristics

One other fact to keep in mind is that most speaker response curves (sound pressure curves) are run with a microphone located directly on the speaker axis. These curves at high frequencies (1,500 cycles or higher) are a bit misleading as a true record of output efficiency, because of the directional properties of this type of speaker. In other words, whereas a curve taken with the microphone located directly on the axis of the speaker would show good high-frequency response for a given cone-type speaker, a second microphone located at an angle, say 45° or 60° off the axis, Fig. 1B, for example, would give an entirely different curve. Thus it may be said that the "beam" effect obscures the inefficiency of a cone-type speaker.

A specially designed horn-type high-frequency unit, however, will give an entirely different result. Due to differences in design, a "tweeter" will give approximately the same sound output at any given frequency within its range regardless of the location of the microphone (see Fig. 1B), assuming of course that the test is run in "free space" and that the microphones are equidistant from the speaker and not more than 90° off the front axis.

As a result the over-all efficiency of a cone-type speaker varies approximately inversely as the frequency above 1,500 cycles, while the efficiency of the horn-type unit is constant for its transmitted range. In fact, the efficiency of the particular "tweeter" used with this amplifier is about 1000% greater at 6,000 cycles than that of the low-frequency unit. Moreover, its frequency range is extended much farther into the high-frequency spectrum than that of the cone speaker. Hence its use as the high-frequency speaker for this amplifier.

Reasons for Dual-Channel Design

There are several reasons for the use of the dual-channel feature. First, it is possible to accomplish complete

separation of the frequency range into bands. Second, since each channel covers only a given frequency band, it is more efficient because frequencies outside its range cannot cause the tubes or channel speaker to overload. Third, it is possible to vary the level as well as the response curve of each channel independently of the other. Last, it is much easier to construct an amplifier which has a restricted hand width than a single amplifier which covers the entire useful A.F. spectrum (16 to 16,000 cycles).

Effect of Sound Interaction

In connection with the use of separate channels for the highs and lows, several interesting questions arise. For example, what is the result of the interaction of the sound waves of a frequency which is reproduced by both speakers (near the extremes of the two channels, i.e. 1,200 cycles)?

Inasmuch as both speakers are reproducing the same frequency (e.g. 1,200 cycles) there will be an interaction of sound waves coming to the listeners' ears. If the speakers are connected so that the sound outputs are in phase the sound waves will reinforce each other, and if the speakers are out of phase, cancellation will take place (the volume will be less). This is assuming that the listener is hearing all the sound directly from the speakers, and none indirectly (by reflection). If such is not the case, proper phasing of the

speakers is not so important because there is then generally much more cancellation due to reflected sound waves from the walls and other objects than from improper phasing.

In other words, where there is little reflected sound, such as in the open air, the two speakers must be in phase or there will be a considerable loss in output due to cancellation. However, in any room where there are many objects to reflect the sound (chairs, walls, and the like) reverberation will be high, and the phasing of the two speakers is not noticeable. In order to change the phase of any speaker, it is necessary only to reverse the voice coil leads (or field connections) of that speaker.

Designed for Good Bass Output

What effect will harmonics caused by the low-frequency channel have upon the high-frequency reproduction?

They would be quite noticeable if their effect were not minimized by filtering. The use of push-pull triodes in the output stage, and also by circuits which do not tend to introduce harmonics.

For this reason pentodes or class B output tubes are "taboo." Great care has been taken to minimize harmonic and amplitude distortion throughout, even in the filtering circuits, with, however, one exception.

(Continued on page 177)

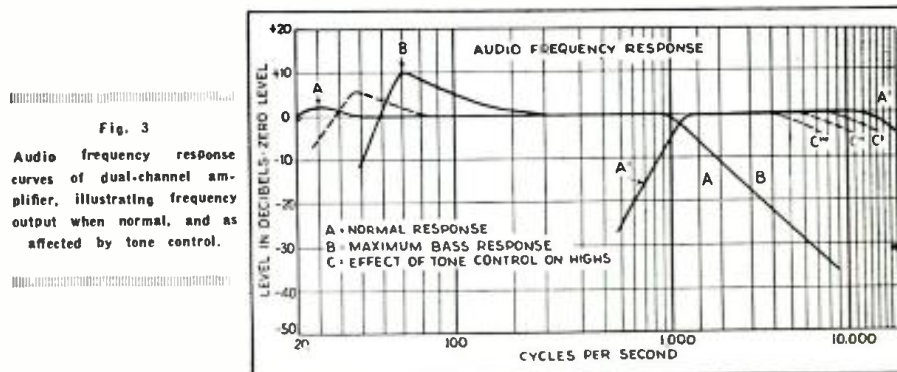

Fig. 3
Audio frequency response curves of dual-channel amplifier, illustrating frequency output when normal, and as affected by tone control.

THE LISTENING POST FOR ALL-WAVE DX-ERS



Transmitter, Viipuri, Finland, is regularly heard.

There is tremendous interest in DX reception in all parts of the world. It is still possible to receive "broadcast" stations (do not confuse this with short waves only) from many parts of the world. Thus, for instance, in this country, stations from Europe and as far as Australia are regularly heard, without any difficulty.

The purpose of The Listening Post is to permit DX-ers to compare reception results and to exchange ideas that will enable them to improve the receiving range of their set. With this in mind, we invite readers who are constantly listening-in to foreign stations on all-wave wavebands, from 15 to 2,000 meters, to write to us concerning their results, and any hints that would enable other listeners to attain equally successful reception. We will be glad to publish letters of general interest, especially, if they are accompanied with suitable illustrations.

By "QSL"

SOME WORLD-WIDE DX CATCHES

ZL2YA—WELLINGTON, N. Z., 5 kw., 570 kc.; operates from 1 to 6 A.M. E.S.T., daily.

ZL3YA—CHRISTCHURCH, N. Z., 10 kw., 720 kc.; operating from 1 A.M. E.S.T., to very late morning hours.

EUROPE

POSTE PARISIEN—959 kc., 100 kw. new transmitter, Paris, France; transmissions commence at 2:12 A.M. E.S.T., and end at 7 P.M. E.S.T.

FECAFP, FRANCE — Radio Normandie, 1,456 kc., 20 kw.; transmissions start at 10 P.M. E.S.T.

BRESLAU, GERMANY—950 kc.; commences transmissions at 12:30 A.M. E.S.T., and concludes at 7 P.M. E.S.T., 60 kw.

FRANKFURT-AM-MAIN — Radio South Western, Germany, 1,195 kc.; starts transmissions at 12:30 A.M. E.S.T., and concludes at 7 P.M. E.S.T.

HAMBURG, GERMANY—904 kc., 100 kw.; same schedules as the preceding two.

BERLIN, GERMANY—841 kc., 100 kw.; same schedules.

MUHLACKER (formerly known as Stuttgart) GERMANY—574 kc., 100 kw.; same schedule as preceding three.

TURINO, ITALY—Radio EIAR, ITO, 7 kw., formerly on 1,140 kc., is said to be wandering of late and can be found within 100 kc. of 1,140 kc.

The Argentine stations are being heard in this country with terrific volume, lately. Stations LS10, LR10, LR5, LR2, LR3, LR4, LR9, LR8, LS2, LS8, LS9, LF3 in the Argentine are the stations that seldom sign-off before 1 and 2, and even 3 A.M. E.S.T. The South Americans being reported are the following:

BUENOS AIRES

LR5—Radio Excelsior, 27 kw., 830 kc.

LR4—Radio Splendid, 20 kw., 990 kc.

LS5—Estacion Rivadavia, 2 kw., 1,110 kc.

LR8—Radio Ciné, Paris, 10 kw., 1,148 kc.

LR3—Radio Nacional, 12 kw., 950 kc.

MENDOZA

LV10—Radio Cuyé, 350 W., 862 kc.; a reliable little station.

BRAZIL, RIO DE JANEIRO

PRA9—Radio Sociedad Mayrink Veiga, Rio de Janeiro, 1 kw., hours: signs off at about 2 A.M. E.S.T.

CE86—less often heard than the others.

CE86—Radio Sud America, Santiago, Chile. Calle Nueva York 80, 840 kc., hours: signs off at 11:30 P.M. E.S.T.; it is heard best at 11 P.M., through CKLW.

"DX-ING" is one of the most fascinating of all hobbies. To sit down at one's receiver and tune in Buenos Aires, Melbourne, or Paris is certainly incredible enough, but what is more incredible—it's being done in the 200 to 550 meter "broadcast" band!

Foreign stations are heard so generally in the broadcast band that even a DX club has recently made its appearance with membership exclusive of those who get foreign stations in the broadcast band.

This is indicative of several things:

(1) Our receivers are more sensitive and selective;

(2) There are more DX-ers than ever before;

(3) These DX-ers are becoming more apt in the art of hearing foreign stations (that last point might include efficiency of aeriels, grounds and tubes);

(4) There is general interest in foreign stations.

For the benefit of the man who has never heard a foreign station in the broadcast band, let us emphasize the importance of the aerial. One may try out 100 aeriels on his receiver—and stop. The one-hundred and first will be the one that is to radically alter reception conditions. Perhaps the DX-er does not have time nor money to experiment with aeriels. Then he may as well put his "super-supers," or what you will, in the parlor and give up the idea.

One man situated on the west coast has discovered through his experiments that a system of directional aeriels, grounded at the far end, accounts for his foreign receptions. Another in New Zealand says that an aerial exactly 1000 ft. long, directional to the northeast, and exactly 15 ft. high, accounts for his championship among New Zealand DX-ers. The writer has a thousand and one of these systems on record, and after his numerous experiments must state—"They are all good, but decide for yourself which is best."

Then there's the second big factor—Patience! Tune the dial of your receiver so slowly, that you could find a microbe on the dial (were such maneuvers necessary). Listen to every unusual program, listen at every spot, but never allow your imagination to get the best of you. (*Make certain of your "catches."*)

Then there's the question of data. An up-to-date log and an up-to-date time chart are indispensable. They are to a DX-er what a law book is to a lawyer. (One of the most up-to-date logs of the entire world, that has ever come under the observation of the writer—and there are few that haven't—is the official organ of a New Zealand DX radio association. Then there is the "Official Short Wave Log and Call Book," published by SHORT WAVE CRAFT.)

Well, let's see what other DX-ers are doing, and what they have to say. Here's a letter from Frank A. Johnson, 59 W. 66th St., Chicago, Ill.

Frank says: "Anybody with a good set can hear foreign signals on an indoor aerial, but they will be weak signals, or perhaps only carriers. If a fellow wants to bring out a signal on the loudspeaker, he's got to put up a good, long aerial. Incidentally, *Poste Parisien* can be heard now, so be sure to try for him." O. K. Frank! By the way, Frank has tuned in so many foreign stations on the broadcast band, at his home in the city of Chicago, that he has gone over to short-waves for diversion. He is the "head judge" in the DX contest of the International DX-ers Alliance of Bloomington, Illinois.

While we're speaking of the International DX-ers Alliance, Charles A. Morrison, the president, has written us a nice letter with some very valuable tips, for the neutral and radical DX-ers, alike.

"The I.D.A. special from CX26, Montevideo, Uruguay, was heard well all over. CP4 notified us that they would
(Continued on page 170)

HOW SHIELDED LEAD-INS MISBEHAVE

The problem of installing a shielded lead-in, for reducing noise, is not a simple one. A great many peculiarities arise when such an installation is made. The author of this article has conducted numerous experiments along these lines, with the result that he has acquired some very practical data which he passes on.

W. E. KEEVER

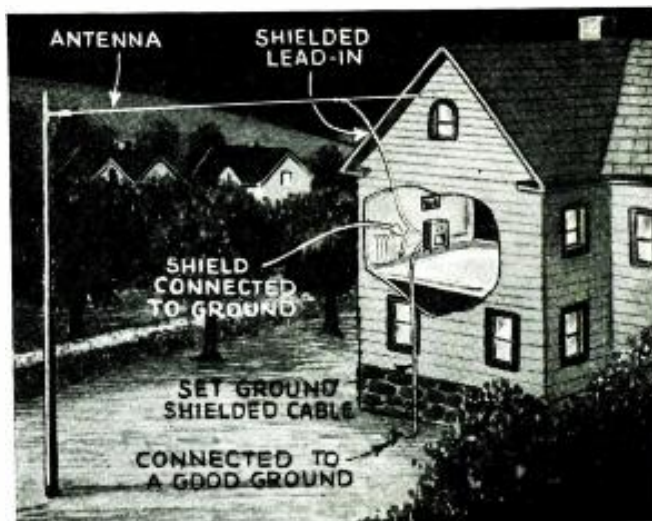

ONE would hardly expect so simple a thing as a shielded lead-in to furnish much material for research. Yet the unexpected always "happens"—the expected only "occurs," or fails to occur. Since this article deals principally with the unexpected, often detrimental, effects of shielded lead-ins, the other side will be disposed of in short order.

The purpose of the shielded lead-in is to short-circuit to ground those inductive disturbances commonly mis-called "man-made static." For the most part they are impulses, so powerful as to force their way into a receiver regardless of tuning, producing forced oscillations or false modulation of the desired carrier frequency. Fortunately, their source is ordinarily below the average level of housetops, and their fields limited, so that proper shielding of the lead-in will often minimize this form of interference. However, disappointment is in store for any one who does not take into account the following facts:

(1) A shielded lead-in to an unshielded or poorly shielded set is a waste of time and money.

(2) No shielded lead-in or transmission system, with or without coupling transformers, can eliminate disturbances picked up by the antenna itself. The latter must be out of the zone of interference.

(3) No such arrangement can eliminate or exclude real (atmospheric) static and still receive desired signals.

(4) No amount of shielding will exclude interference that enters the set by way of the power supply. Use a line filter.

(5) Shielding the lead-in cuts just so much from the effective length of the antenna. For equal sensitivity, the antenna must be longer than one with exposed lead-in.

(6) To be effective, the lead-in shield must be grounded, and the manner of grounding may produce many unlooked-for results such as external heterodyne, mixing of long waves with short, automatic volume control, or 80 per cent reduction in signal strength!

Shield the Ground Lead

It is a good idea to shield the ground wire even though it may be short, because this wire is nearly always in the interference zone, and a sensitive receiver will pick up induction through a 6-ft. lead. Aside from interference, there is another reason why a long ground wire is objectionable. The antenna acts as one plate of a condenser, the earth forming the other "plate." The antenna also is a stationary armature in a moving field, generating the current that charges it. All wire above ground is more or less in this field, and thus really a part of the antenna. Voltage reaches its peak at the free end, while current is strongest at the earth connection. Nearly all modern broadcast receivers cut in on the current, the necessary voltage being developed

across the grid-to-cathode capacity of the first R.F. tube, through a transformer or through the drop across a choke or resistor in the antenna circuit. Hence the best connection for the "current-fed" receiver is near the ground.

The R.F. picked up by a long ground is liable to be somewhat out of phase—more of a hindrance than a help to the antenna proper. It is good policy to shield the ground wire even though the antenna lead-in is unshielded. In this case it seems to make little difference where the shielding is grounded, although the lower end, right on the ground clamp, is most convenient. When the lead-in also is shielded, a different connection may be preferable. (See report of experiments, further.)

Getting back to the lead-in: it will be realized that 20 to 30 ft. of metal shielding surrounding a central wire and separated therefrom by a rubber dielectric (insulation) forms a condenser of fairly large capacity. When one "plate" (the shielding) is directly grounded, desired signals as well as inductive disturbances are shorted out of the receiver!

Nor is this all. The shielding also acts as an independent antenna. Every grounded conductor has its own resonant frequency—this includes water pipes as well as power and telephone wires. When any such chance circuit closely parallels the antenna or lead-in, a "mix-up" is certain to occur, its seriousness depending on the strength
(Continued on page 172)

Fig. 1
Experimental circuits were tried.

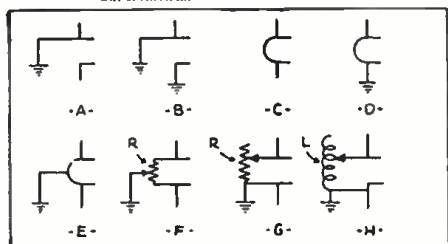

Fig. 2
One practical method that worked.

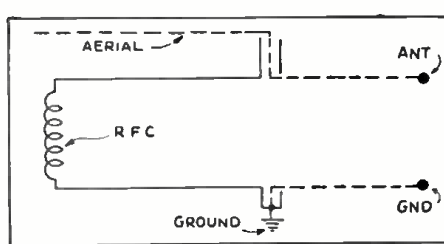
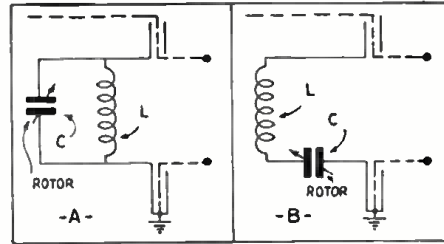

Fig. 3
This method has peculiar features.



HOW TO MAKE A "GRID-DIP" OSCILLATOR

Here is one more item to make the Service Man's laboratory complete. It is an oscillator with a milliammeter in the grid circuit, completely shielded and operating from A.C. power supply. When a circuit connected to it is in resonance, immediate indication is obtained by a "dipping" of the needle of the meter which is caused by power absorption from the oscillator. It is a simple, accurate, and novel device for calibrating, aligning, and other service work.

JOSEPH LEEB

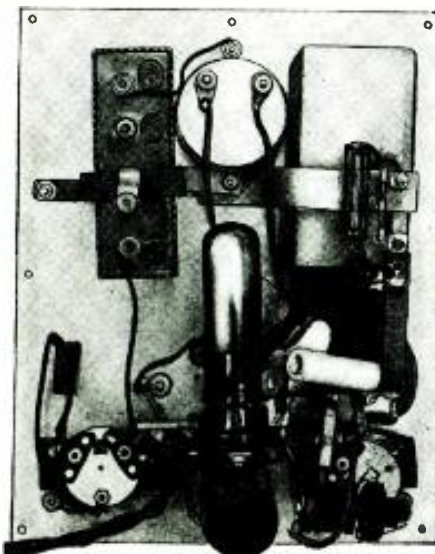
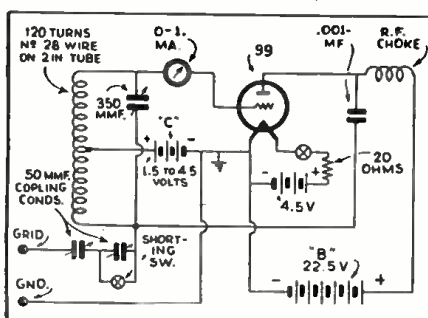

Fig. A. above
.. Internal construction and layout.

Fig. 1. below
Fundamental circuit. Battery operation.



EVERY radio Service Man who takes his work seriously realizes the value of a resonance indicator in checking up tuned circuits, etc. The instrument to be described is the result of a careful investigation of the features of some of the existing types of oscillators. It might be interesting to follow the stages of evolution which finally produced the instrument in its present form.

Figure 1 shows the schematic wiring arrangement of a simple oscillator. For the sake of simplicity, the parts comprising the instrument were mounted and wired "breadboard fashion." However, the necessity of completely shielding the unit was made obvious by its instability of operation and broadness of tuning. Accordingly, a metal box, 8 x 10 x 6 ins. deep, was secured, with an 8 x 10 in. aluminum panel to match.

The parts of the oscillator were re-mounted and re-wired on the metal panel, and the results obtained were quite satisfactory. In order to make the unit entirely self-contained, a 4½ V.

"C" battery was used for the filament supply. This ran down very quickly when the instrument was left turned "on" for any great length of time, as was necessary when there were many sets to be adjusted. It was therefore deemed advisable to re-design the oscillator to operate from the 110 V. A. C. line.

Figure 2 shows the converted wiring. This was a big improvement upon the previous arrangement, since it precluded the annoying possibility of a run-down filament battery, in the event that the instrument was accidentally left turned "on" or used for any lengthy period of time. Still, this arrangement did not give a complete solution to the problem. An examination of the filament circuit, shown in Fig. 2, will disclose the fact that a series resistor is used to cut the line voltage down to the proper value required by the filament. This method of voltage reduction was found inefficient, as any slight line variation affected the stability of the

(Continued on page 168)

Fig. 2
One form of "electric" operation of grid-dip oscillator which may be used.

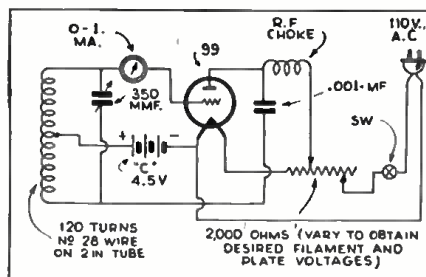
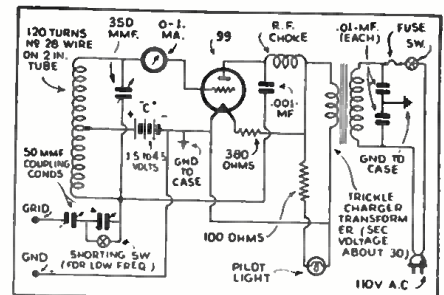

Fig. 3
Most efficient circuit, now employed.



A NEW COPPER-OXIDE PHONO. PICKUP

Something entirely new — a phono-pickup which requires only one stage of amplification to supply full-room volume.

A. BARBIERI*

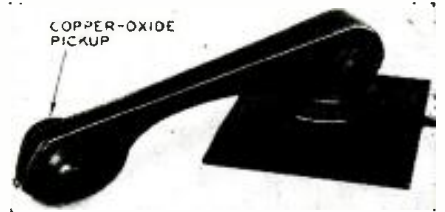

A NEW phonograph pickup that requires only 1 stage of audio amplification and gives lifelike reproduction. Former phonograph pickups required at least 2 stages of amplification. Since many sets have only 1 stage of A.F., it usually requires the addition

* Acoustic Engineer, Amberite Corp

of an audio stage to the radio set, or certain changes in the detector tube circuit so that it might be used as an amplifier.

With this idea in mind, this new pickup was developed with an output large enough so that the single audio stage would provide the necessary amplification to obtain full power output of the

receiver. The output of this "copper-oxide" pickup is +10 db., as compared to only -15 db., for an average "magnetic" unit.

Also, the pickup is not a self-generating device as its predecessors of magnetic type. It consists of crystals of
(Continued on page 178)

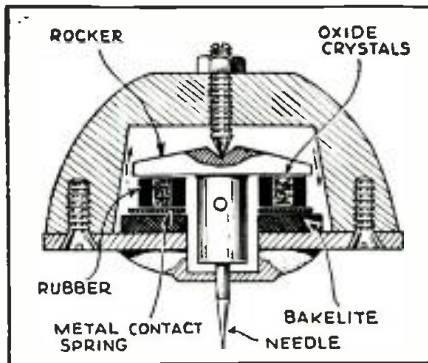
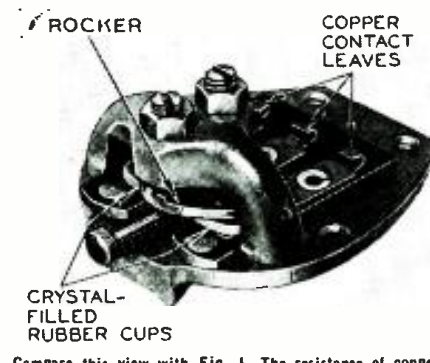

Fig. 1
A cross section of the pickup.



Compare this view with Fig. 1. The resistance of copper-oxide crystals in two soft-rubber cups varies as a rocker compresses first one cup then the other.

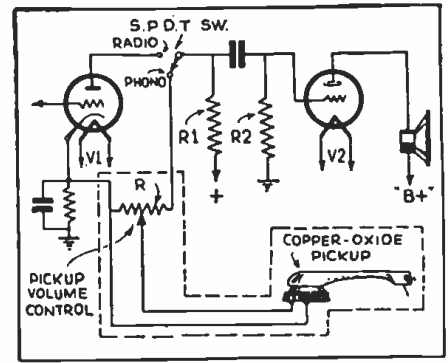

Fig. 3
Connections to the power tube in the set.



Fig. A
The complete power amplifier and current supply.
Photos Courtesy: Bud Speaker Co.

NEW P.A. EQUIPMENT

Here are some recently developed devices for the P.A. installation man which will permit him to make quicker and better installations than before, for indoor or outdoor work.

AT THIS time of year, wide-awake Service Men find worth-while profits in the installation and maintenance of P.A. equipment. This includes both indoor and outdoor installation in

hotel, dance pavilions, recreation halls, stores, restaurants, boat houses, clubs, and beaches, amusement parks, carnivals, athletic fields, boxing and wrestling rings and myriads of other places

where people gather.

And at this time, local political parties are preparing for their fall campaigns in numerous communities throughout the country. Many of these parties can use P.A. installations in halls and on trucks, etc., to bally-hoo their candidates. Service Men can sell or rent P.A. equipment and maintenance to these parties if they are approached correctly. Experience and a knowledge of the local political set-up are the best gauges to use in approaching the party leaders with sales of this type in mind.

While school appropriations in many sections of the country have been cut down tremendously, there are still some locations where a principal of a school or a board of education can be convinced that a P.A. installation, or a call system permanently installed, would be a good thing. Naturally, the summer time, before school opens, is
(Continued on page 178)

Fig. B
The condenser microphone and preamplifier.



An enlarged view of the mike and "head amplifier." The preamplifier is completely contained in the mike case, power being obtained from the main amplifier current supply unit.

Fig. C
Two views of the reproducer on its floor stand.

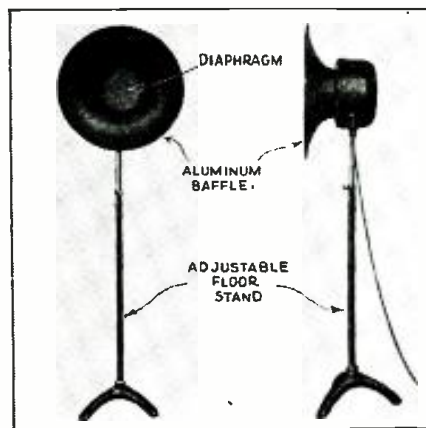

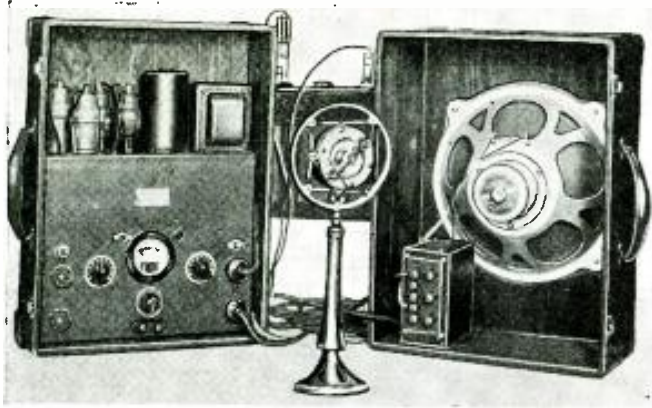

A UNIVERSAL 6 VOLT P.A. SYSTEM

The features of the P.A. system, described in this article, permit its use wherever portable equipment is desired and power is not available. It is completely self-contained, and operates from a 6 volt battery.

LEON J. LITTMANN*

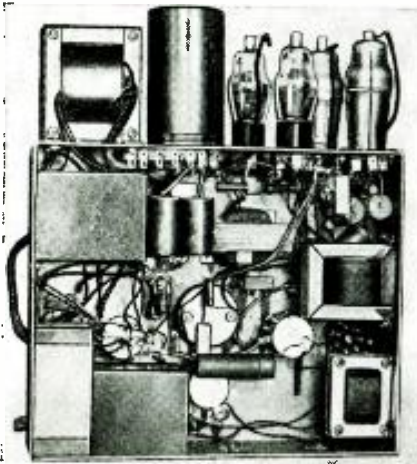

Inside view illustrating layout.

THIS P.A. amplifier system features a self-contained universal input control panel, 11 in. dynamic speaker (separately removable from the amplifier), as well as convenient facilities for storing a microphone, microphone stand, extension cables, etc. It may be set up for operation in a second—merely clip its "A" leads onto a storage battery!

However, although primarily intended for 6 V. operation, provision is made to permit its use with an external A.C. operated power pack as well, by merely inserting the amplifier plug into the self-contained 6 V. operated pack or into the corresponding socket of an A.C. operated power pack.

An outstanding item is the unusually

LOW POWER CONSUMPTION varying from 1.9 A. at no-load to 6.4 A. at full load; the average power consumption is only about 3 1/3 A! Thus the ordinary 120 A.H. storage battery would assure 36 hours of continuous uninterrupted service, without having to be recharged. As a 25 W. automobile head lamp has the same power consumption, it may be easily seen, that if the amplifier is connected to an ordinary automobile storage battery, the additional drain would make it unnecessary to advance the charging rate of the car generator, to keep the battery charged. The low power consumption of 1.9 A. is made possible by the use of switch Sw. 1, which permits the "B" voltage con-

(Continued on page 169)

*Chief Engineer, Coast-to-Coast Radio Corp.

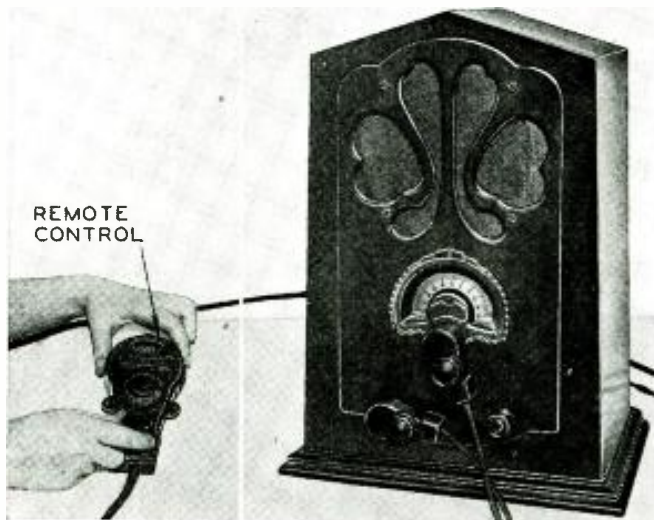

A NEW REMOTE CONTROL UNIT

Tuning a receiver by means of remote control devices is rapidly becoming more popular. Most units of this nature, however, are too complicated and costly to install. The one described here is an exceedingly simple and trouble-proof type.

Fig. A. Remote control is easy to install.

Courtesy Fada Radio Corp.

Fig. 1. Mechanical "make-up" of unit.

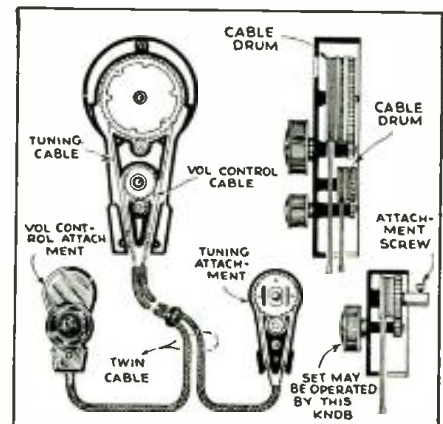

THE REMOTE control of radio receivers is not new, but the devices used up to this time have, on the whole, been both complicated in construction and comparatively expensive. Practically all of the devices used up to this time have been electrical in nature, the control mechanism operating a motor to drive the tuning and volume controls on the set.

The device shown in the figures, however, is extremely simple, being entirely mechanical. It consists of a small control head equipped with two knobs and a dial. To this control head is attached

a single tubular casing approximately 1/4-in. in diameter, containing the drive cables. Two cables are used, each of which winds on a drum in the control head. At the other end of this pliable cable is another set of knobs which replace the usual tuning knob and volume control knob on any modern radio set.

The control head may be placed in any part of a room up to a distance of 15 ft. from the radio receiver. It is interesting to note that the remote control unit does not prevent operation of the receiver directly as the knobs which are

(Continued on page 166)

A. C. - D. C. MIDGET SET TUNES 15-3,000 METERS

The features incorporated within this receiver are: dynamic speaker reproduction; operation from 110 V. A.C. or D.C.; employs latest types of tubes; and, by means of plug-in coils, reception from 15 to 3,000 meters.

HERE is conclusive proof that a large, bulky receiver of multitudinous parts and tubes is not really essential for "all-wave" reception. The receiver shown here, in addition to covering the complete broadcast and

short-wave spectrums, also permits foreign station reception, inasmuch as its tuning range extends to 3,000 meters. Those who have read the description of the "Long Wave Tuner" in August RADIO-CRAFT will remember



that a great many of the broadcast stations in Europe operate above our broadcast band (550 meters). For example Radio-Paris broadcasts on 1,648 meters, Oslo (Norway) 1,181 meters, Moscow (No. 1) on 1,724 meters, etc., all of which wavelengths are seldom included in most "all-wave" receivers.

The greatest feature of this set is that the wavelength ranges (wave bands) are changed by the simple expedient of plugging in or out the necessary coil, a receptacle for the coils being provided on the side of the cabinet. The receiver and cabinet is of midget design, but, despite the miniature size, the efficiency of the set and the number of programs obtainable are surprising.

(Continued on page 168)

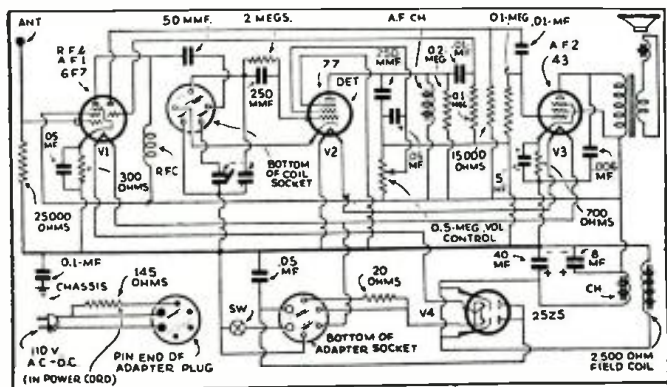

Fig. 1
Wiring diagram of midget receiver. tuning range 15-3,000 meters. Four tubes are employed; 6F7 as R.F.; 77 for det.; 43 for power audio, and 25Z5 rectifier.

Courtesy, Fordson Radio, Inc.

HI-GAIN AUTO ANTENNA COUPLING SYSTEMS

The devices described help overcome the handicap caused by the inefficiencies of most car antennas. A properly installed car antenna will help minimize ignition interference, and raise reception possibilities.

A. H. LYNCH*

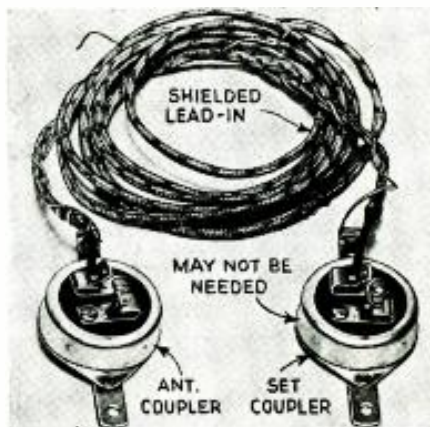

THE multiplicity of antenna systems for auto-radio use have confused many Service Men. The literature supplied by some of the manufacturers may be responsible for this situation. In any case, it exists, and it is our task

*Lynch Radio Labs., Inc.

Fig. 1
V-shaped under-car aerial for coupes.

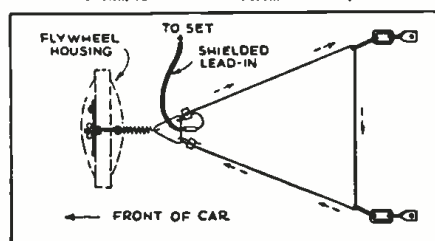

to see that something is done to clarify the situation.

The ideal antenna for a car is a fairly large mesh, located in the roof. Many car makers are supplying such aerials, as standard equipment. Simplicity and low cost as well as comparative freedom from interference make the use of a shielded lead-in, from the antenna to the receiver, essential; the shielding is generally grounded at one or several points along its length. While this type of installation is fine in a sedan or other cars with a fairly large roof area, it is not so good for a modern coupe or cabriolet, where the roof area is small. Here the triangular type of under-car antenna has been found very satisfactory.

Let us consider the under-car antenna, of the triangular type; suspended between the rear axle and the fly-wheel housing (see Fig. 1). This type is by far the simplest to install and it has about 70% of the pick-up of a triangular screen of the same size at the same height above ground. Since this type of aerial gives increasingly satisfactory results as the distance above the ground is decreased, a compromise between best signal strength and freedom from road obstructions must be made. Then, too, the position of the 3 sides of the triangle should be such that the flexing produced by the most severe bumps will not be sufficient to make the wires strike any portion of

(Continued on page 166)

THE ANALYSIS OF RADIO RECEIVER SYMPTOMS

OPERATING NOTES

WHAT THIS DEPARTMENT IS FOR

It is conducted especially for the professional Service Man. In it will be found the most unusual troubles encountered in radio service work, written in a practical manner, by Service Men for you.

Have you, as a professional man, encountered any unusual or interesting Service Kinks that may help your fellow workers? If so, let us have them. They will be paid for, upon publication, at regular space rates.

APEX MODEL 20

A CASE of very low volume was the complaint for a service call on a U. S. Radio and Television Corporation Apex model 20 midget receiver. A check-up with the set analyzer failed to show any variation of the tube voltages from normal. Checking the fixed condensers revealed an open .05-mf. blocking condenser in the input circuit of the type 24 detector stage. The defective unit was replaced with a cartridge type condenser similar to the original unit.

This circuit is rather unusual in that a single transformer winding (See Fig. 1) is used to supply the type 24 heaters (2.5 V.) and the 71-A filament (5 V.).

The dynamic speaker in this receiver has two separate field coils; a 935 ohm section in the negative side and a 5000 ohm section in the positive side of the power supply system.

a defective tube or an open section in the filter condenser block, it is well to check the two 0.1-mf. condensers connected from each side of the type 26 filament wiring to ground. These condensers are of the cartridge type and will be found next to the 2nd and 3rd R.F. sockets.

This chassis incorporates a "hum-reducing" unit, consisting of the 3,000 ohm (green) resistor and the 1.-mf. condenser connected from the arm of the center-tap resistor to the "B+" end of the push-pull input transformer, as shown in Fig. 3. A defect in either the resistor or the condenser will increase the amount of hum in the receiver output.

This hum-reducing system can be applied with favorable results to receivers using the same basic circuit (Bosch 28 and Majestic 72) as this Silvertone receiver.

GEO. JEHL.

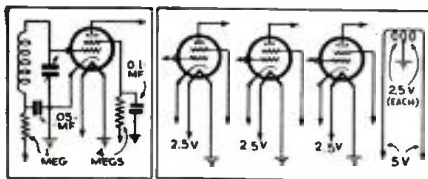

Fig. 1
One winding supplies all "A" voltages.

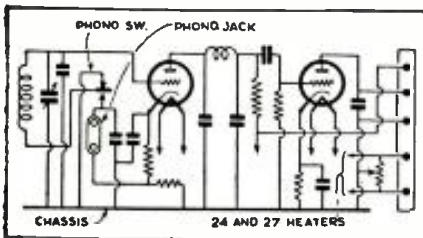

Fig. 2
Location of components in Eveready set.

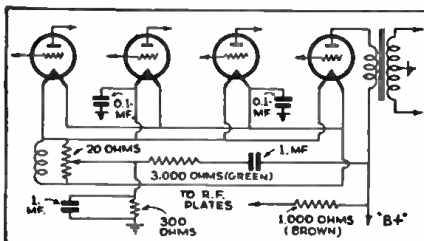
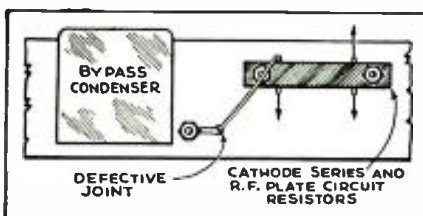

Fig. 3, above
The "hum-reducer" may develop defects.

Fig. 4, below
An expanding resistor causes fault.



EVEREADY SERIES 50

IF IT becomes necessary to align the tuning condenser gang on the Eveready Series 50 model, you might have a difficult time locating the adjusting condensers. These condensers cannot be reached from the back of the chassis, but if the receiver is removed from the console, the 3 trimmer condensers are accessible at the front of the chassis.

The phonograph switch is on the gang condenser (rotor of detector-stage section) and can be reached from the back of the chassis. The arm of the switch is actuated when the tuning condenser dial is turned to the PHONO. position at the low-frequency end of the dial, as shown in Fig. 2. A case of weak or no reception might be due to dirty switch contacts or failure of the contacts to close properly. Clean the contacts and bend the switch blades until the contacts are opening and closing properly.

The speaker output transformer is located in the chassis, and the 2,500 ohm field coil is used as a filter choke in the positive side of the plate power supply.

The set screw located at the back of the chassis is the hum-control adjustment, a variable center-tap resistor across the type 24 and the 27 heaters.

ATWATER KENT 46

RECENTLY, we encountered a very interesting and rather unusual problem in tracing down and locating the cause for loud crackling and snapping noises heard in an Atwater Kent model 46 receiver. The unusual part of it was that this noise lasted only for about 4 or 5 minutes; after that the receiver performed in a perfectly normal manner. After the noise had subsided the receiver switch could be turned off and on, within short periods of time, and the reception would still be normal and free from noise. It was noticed, however, that if this period, of turning the receiver off and on, was extended to, say, 10 minutes, this unbearable noise would start in anew. From this peculiar behavior of the receiver, the conclusion was drawn that this action was due to a loose or defective part, which in turn was subjected to the influence of generated heat, somewhere in the set. The tubes were suspected, but complete replacement with new tubes proved that these were not at fault.

The trouble was finally located by pressing down the top of the flat, wire-wound cathode series and R.F. plate circuit resistors, shown in Fig. 4. Broken off wires in the resistor strips were suspected, but again we were fooled, replacements definitely proved these to be free from any defects. The leads from these resistors were then traced to their respective terminating points, one by one, and the soldering iron was applied and the result noted.

(Continued on page 171)

SILVERTONE MODEL J

IF HUM on the Sears, Roebuck Silvertone model J receiver cannot be eliminated by adjusting the 20 ohm filament center-tap resistor, and it is not due to

SHORT-CUTS IN RADIO

FIRST PRIZE \$10.00
SECOND PRIZE 5.00
THIRD PRIZE 2.50
Honorable Mention

EXPERIMENTERS: Three cash prizes will be awarded for the best "short-cuts" — time- and money-saving ideas — submitted by readers of **RADIO-CRAFT**; Honorable mention will be given for all other published items concerning radio and its allied fields.

Send us your "kinks" right away. Awards will start with the October issue.

EMERGENCY SOCKET WRENCH

(Fig. 1)

Francis C. Wolven

THOSE who have occasion to fasten square-head cap screws will find the tool illustrated a very handy device. All that is required is a piece of heavy gas line that has been hammered over the square tang of a rat-tail file.

VOLTAGE REGULATOR REPAIRS

(Fig. 2)

Earl B. Fox

IT IS occasionally necessary to repair the voltage regulator that is used in, for instance, Majestic models 70 and 90 receivers. Therefore, Service Men will be interested to know that the wire-wound resistor in some of the Philco "A-B" eliminators may be used to rewind the burned-out regulators (as shown).

A HOME-MADE LAPEL MIKE (Fig. 3)

Bill Bartlett

AN EXCELLENT lapel microphone may be made from a tin box, a block of wood, a piece of carbon rod sal-

vaged from a defunct dry cell, a piece of cellophane, and a few miscellaneous items, as shown.

A disc ¼-in. thick is cut from a carbon rod and shaped as shown in the illustration. Around the top rim of the cup thus formed, glue a felt or cotton washer. Fill the cup half-full of silver filings. Lash a piece of radio crystal, such as galena or silicon, to a strip of copper foil by means of very fine copper wire. Make a cellophane diaphragm to fit the block of wood (balsa is best). Force the crystal through a hole in the diaphragm made by means of 2 short razor slits at right angles. Glue the cellophane diaphragm to the felt washer and wooden rim. Draw taut and hold in position until the glue has set. A piece of fine screening may be put over the finished instrument to protect the diaphragm. Connect into circuit the same as a regular carbon microphone.

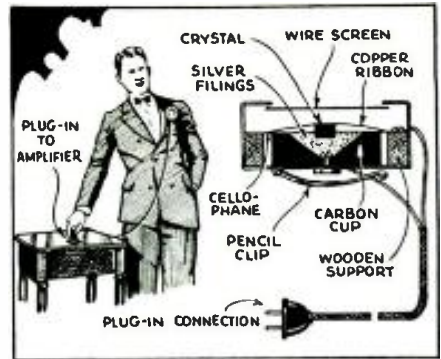

Fig. 3. A home-made lapel mike.

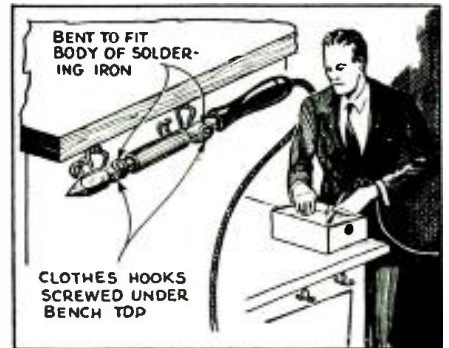

Fig. 4. Soldering iron rack.

HANDY SOLDERING IRON (Fig. 4)

Walter F. Kempe

A HANDY soldering iron rack may be made from ordinary clothes hooks. Bending over both "wings" of the hook at the tip end of the soldering iron will make it more convenient to continually replace the iron in one position.

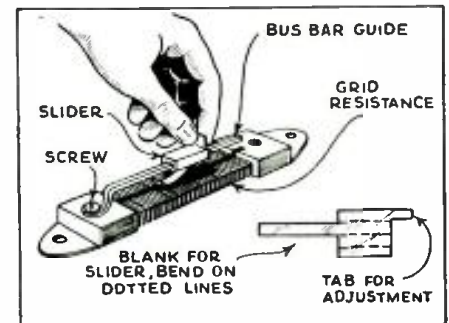

Fig. 5. Adjustable grid suppressors.

ADJUSTABLE GRID SUPPRESSORS

(Fig. 5)

Francis C. Wolven

AN INEXPENSIVE grid suppressor may be made by bending a piece of shim brass to fit a short length of square bus-bar fastened as shown. The slider may be adjusted by means of a screwdriver.

Many receivers using fixed grid resistors for oscillation control can be greatly improved by a reduction in the resistance value—by this method.

(Continued on page 174)

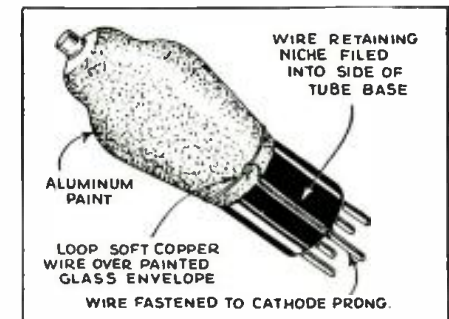

Fig. 6, above. Home-made shielding.

Fig. 7, below. Tube-base plug.

Fig. 1. A home-made wrench.

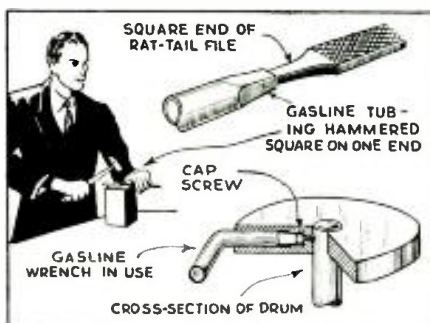
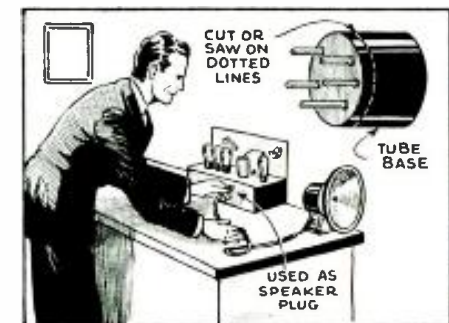
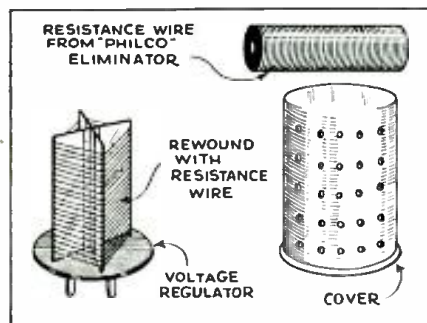
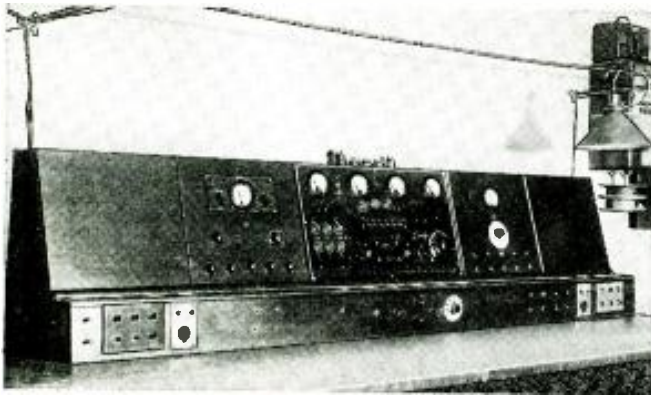

Fig. 2. Ballast-resistor repairs.



READERS' DEPARTMENT

A department in which the reader may exchange thoughts and ideas with other readers.



Mr. Ditty describes this efficient radio test bench.

A TEST BENCH SUPREME

Editor, RADIO-CRAFT:

Some of the readers of RADIO-CRAFT may be interested in a description of our radio service bench, shown above, in which we take considerable pride.

The end panels are for future use. The center panel is a Day-rad instrument rebuilt for modern circuit analysis. The panel to the right of center contains a condenser leakage, flash and capacity tester. The panel to the left of center contains a Supreme 4 range, calibrated ohmmeter with selector switch; also, a "condenser substitute" in 15 steps from 500 mmf. to 8 mf., and a "resistance substitute" in steps of 100 ohms from 100 ohms to 1 megohm.

The extreme front vertical panel contains A and G terminals on both ends and in the center. The A.C. outlets are duplicated on either end, as well as the soldering iron holders, external voltmeter, flash test, ohmmeter, and condenser and resistor substitute terminals. The soldering iron outlets are wired so that resistance may be cut in for low heat.

The center portion contains an outlet for the analyzer cord. A selector switch is provided by which one may obtain a direct continuity reading from any socket terminal to a selective return. A speaker field substitute will, by proper coupling, allow any radio set to be "played" through a magnetic speaker. (This reproducer is mounted on a slanting baffle below the bench.)

All units are mounted with correct scales and indicating lights where necessary. The horizontal shelf contains 14 metal cups for miscellaneous use of screws, washers, knobs, etc. The novel lighting arrangement will allow the Service Man to place 1 of 2 lights at his convenience. The portable equipment consists of an oscillator, 2 analyzers and 2 tube checkers.

A. V. DITTY,
Groce Electric Co.,
Columbus, Ohio.

As has been shown in the series of articles, "Uplifting the Servicing Profession," the appearance of the testing department of a radio service shop goes a long way toward gathering in refractory radio sets.

HELLO, NEW ZEALAND!

Editor, RADIO-CRAFT:

I would be very glad to receive copies of RADIO-CRAFT

from any readers having same to spare. I am in the hospital, having been confined here over 2 years, and anticipate it will be many months before I will be enabled to leave, so you will understand how welcome any letters or reading matter will be. I have not been able to get your informative and interesting journal for some time. So I trust my appeal will not be in vain, and wish RADIO-CRAFT luck.

JAMES RAMSAY,
282 Dominion Rd. S. 2,
Auckland, New Zealand.

"UPLIFTING SERVICING"

Editor, RADIO-CRAFT:

Being a constant reader of your magazine I must compliment you on the article, "Uplifting the Service Profession," as I feel this is the weak point in the radio industry. Service Men today are rated according to the money they make for their boss instead of the amount of service they really are capable of.

There is one thing though, mentioned in the article, that I could never quite see through and that is to equip a service shop with a lot of expensive instruments. (I am strictly in favor of substitution methods in testing radio receivers—and an article I sent to this magazine a few years ago was published on this point.)

I believe a service shop is in existence to service and repair radio receivers, not to design them, and a competent man with very few tools can do that thing very nicely, while an incompetent man with extensive test equipment cannot get a decent job out of his hands, and I feel that *it is the men* more than the equipment that need a push.

As I have been employed by RCA as a tester and trouble shooter I have been able to personally observe the surprising amount of work that our department could accomplish with very little equipment.

Every conceivable kind of trouble was located in many different receiver models, with nothing more than a signal generator, output meter, ohmmeter, continuity tester, and multiple-range voltmeter. This was all the equipment any man had in the entire department and I'm convinced that this is pretty near enough for the average shop. Although a calibrated condenser or capacity indicator is a great help it can be eliminated from the average shop as there is always a variety of condensers around to take care of troubles encountered in tuning and filter circuits.

(Continued on page 178)

Follow this circuit in converting A.C.-D.C. sets for battery operation.

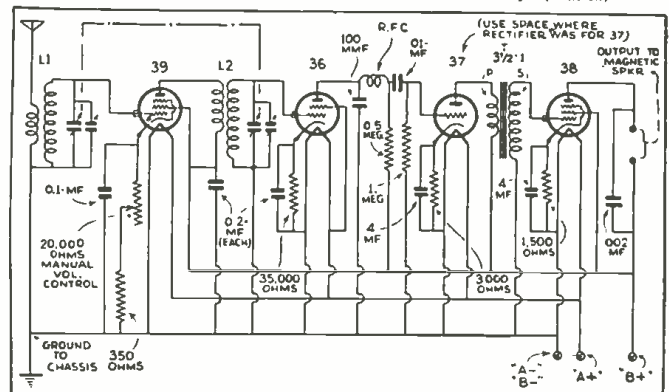

HOWARD EXPLORER MODEL W DELUXE 19 TUBE ALL-WAVE SUPER.

(Uses single-purpose tubes to secure extreme circuit stability; wavelength range, 13.6 to 2.142 meters; provides for either inverted-L or doublet antenna; neon resonance indicator; zero-beat oscillator; variable Q A.V.C.; tone control; variable A.V.C. parallel push-pull output 2A5s.)



A 19 tube radio receiver in its home. Airplane-type dials are used; only the tuning dial sector of the band in use is illuminated, as the band switch is turned.

Schematic circuit of the A.F. amplifier and power pack chassis. There are 9 tubes in this section of the instrument. A "theatre"-type dynamic speaker is used.

Until very recently the general practice has been to utilize the new tubes at their maximum capabilities. Consequently, a slight change in characteristics would greatly affect the operation of the complete receiver. However, this 19 tube set is designed to utilize its tube complement very conservatively, with the result that great stability has been achieved which, after all, is a major factor in securing satisfactory reception, especially on the short waves.

Note: it is inadvisable to attempt to realign the set except as a last resort. The recommended procedure, only to be used by expert radio Service Men, is as follows:

To align the I.F. circuits feed the I.F. service oscillator test signal into the control-grid of V2.

When aligning R.F., I.F., or oscillator circuits turn A.V.C. adjustment (slotted shaft) to extreme left. The I.F. trimmers are very critical, greatly affect the performance of the set, and must be carefully resonated.

Aligning R.F. and Oscillator Circuits

Adjust A.V.C. control to extreme left position. It is unnecessary to remove the set oscillator tube. Align the circuits only in the sequence given.

To align the set oscillator turn its trimmer all the way out and then select the strongest signal when turning it in; set insensitivity near the center of the dial will result if the wrong oscillator signal is used.

Bend the variable condenser plates for kc. dial alignment only in the broadcast band. Before adjusting any band, make certain that the pointer of the station indicator is set on the last black line when the dial is turned all the way to the left on the broadcast band just above .55 (Maximum capacity of the variable condenser).

Long-Wave Band

Turn the band indicator to .15-.35, set the dial to .35, and feed 350 kc. into the antenna post. Resonate the trimmer (not green coded on the trimmer washer) in the long-wave oscillator can. Align the R.F. and antenna stages. Reset dial to just above .17 and resonate the green coded oscillator trimmer at 175 kc. Recheck the 350 kc. setting.

Broadcast Band

It is necessary on the broadcast band only that a metal plate with holes in line with the trimmer nuts be used so that the circuits are not detuned when the regular base plate is screwed back on.

Turn the band indicator to broadcast .55 to 1.5, set the dial to 1.4, and feed in 1,400 kc. Resonate trimmer 14, R.F. trimmer 7 and the antenna trimmer (knurled knob extending from top of antenna coil can). Now rotate dial to .55 and resonate trimmer 10 at 550 kc. Recheck the setting at 1,400 and bend plates of variable condenser at 950 and other points where necessary to secure kc. reading on dial.

Short-Wave Band No. 1

Turn band indicator to 1.5 to 3.5, set dial to 3.5, and feed in 3,500 kc. service oscillator signal. Resonate trimmer 13, R.F. trimmer 6 and antenna trimmer 3. Rotate dial to .55 on broadcast band. (The short-wave dial calibration may be inaccurate at this point and the .55 figure corresponds to 1.5 on short-wave band No. 1.) Feed in 1,500 kc. and resonate trimmer 9. Recheck at 3,500 kc.

Short-Wave Band No. 2

Turn band indicator to 3.5 to 9, set dial to about 8.9 (due to off-calibration this corresponds to 8.5), and feed in 8,500 kc. Resonate trimmer 12, R.F. trimmer 5 and an-

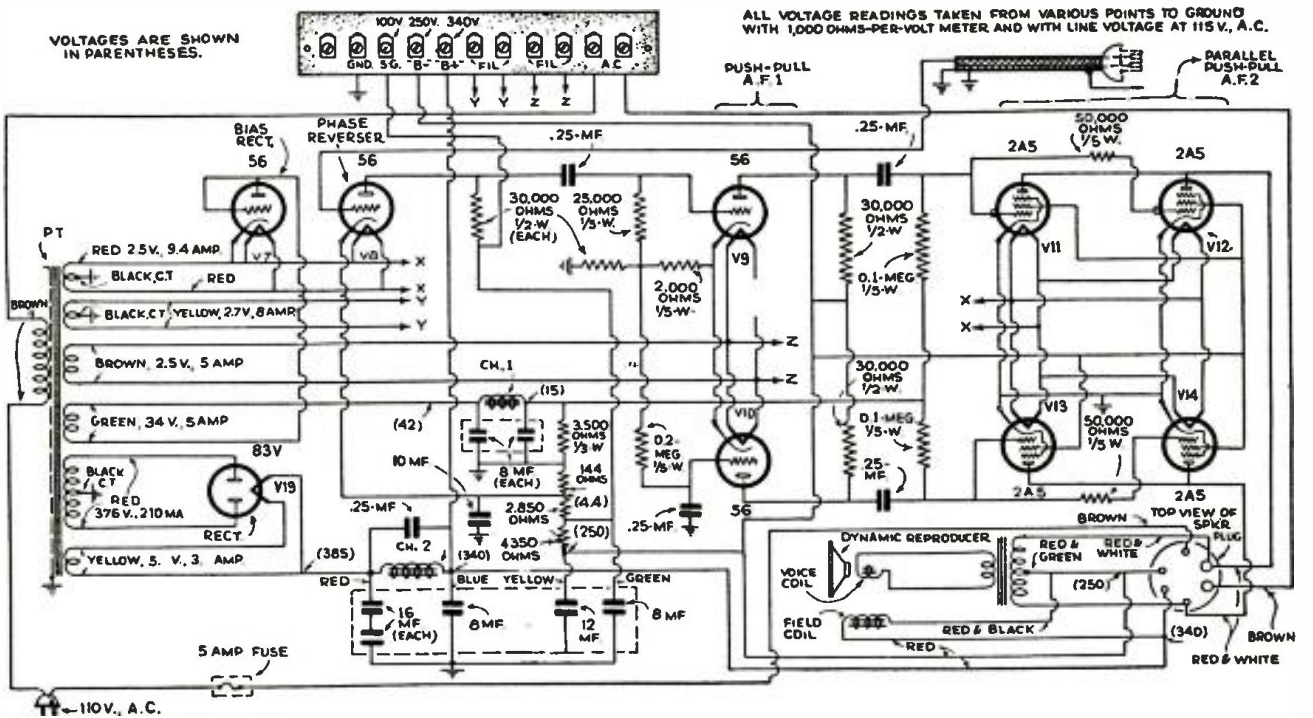

RADIO-CRAFT'S INFORMATION BUREAU

SPECIAL NOTICE

Those questions which are found to represent the greatest general interest will be published here, to the extent that space permits. (At least 5 weeks must elapse between the receipt of a question and the appearance of its answer here.) Mark such inquiries, "For Publication."

Replies, magazines, etc., cannot be sent C.O.D. Back issues of RADIO-CRAFT prior to December, 1932, are available at 50c per copy; except the following issues: 7/29, 2, 3, 4, 6, 7, 9 and 11/30; 5, 8 and 9/31; and 10/32, which are out of print. Succeeding issues are still available at the regular price of 25c per copy.

Inquiries to be answered by mail MUST be accompanied by 25c (stamps) for each separate question; answers are subject to subsequent publication if considered of exceptional interest.

Furnish sufficient information (in reference to magazine articles, be sure to mention issue, page, title, author and figure numbers), and draw a careful diagram (on separate paper) when needed to explain your meaning; use only one side of the paper. List each question. Be SURE to sign your name AND address.

Enclose only a STAMPED and self-addressed envelope for names and addresses of manufacturers; or, in connection with correspondence concerning corrections to articles, as this information is gratis.

Individual designs can be furnished at an additional service charge. The fee may be secured by addressing the inquiry to the SPECIAL SERVICE department, and furnishing COMPLETE specifications of desired information and available data.

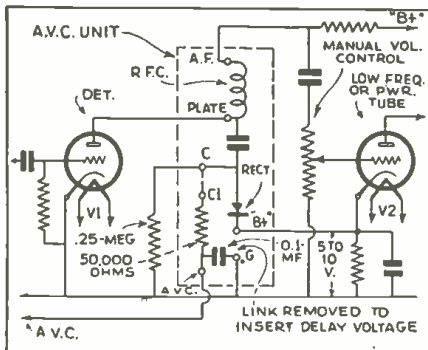

Fig. Q.276. An A.V.C. "add-on" unit.

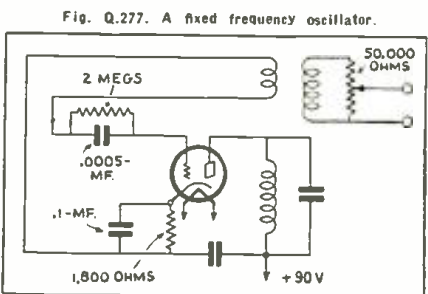

Fig. Q.277. A fixed frequency oscillator.

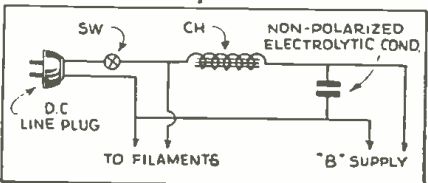

Fig. Q.278. Non-polarized electrolytics.

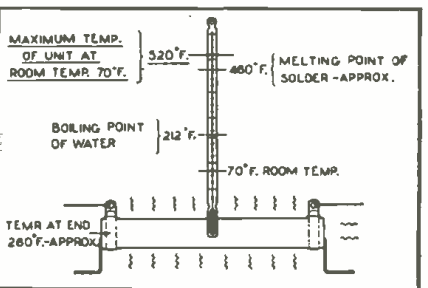

Fig. Q.279. Finding "watts dissipation."

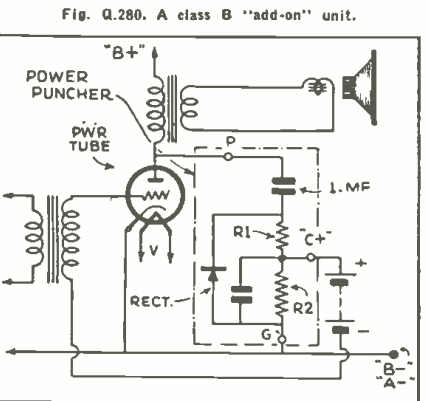

Fig. Q.280. A class B "add-on" unit.

DOUBLET ANTENNAS—A.V.C.

(276) John L. Davis, Everett, Mass.
(Q.1) I understand that one of the copies of RADIO-CRAFT contains construction details for a doublet short-wave antenna. Please advise in which issue this information appeared.

(A.1) There has been some information published recently in RADIO-CRAFT concerning short-wave antennas. However, extensive data has appeared in numerous issues of SHORT WAVE CRAFT. This magazine is published by Popular Book Corp., 99 Hudson Street, New York City. The July and August, 1934 issues of RADIO-CRAFT contain the 2-part article, "Important Facts about the New All-Wave Antenna Systems," in which doublet antennas are illustrated and described.

(Q.2) In the June, 1934 issue of RADIO-CRAFT, page 715 was illustrated a unit for adding A.V.C. to any set. Is a circuit of this instrument available?

(A.2) The schematic circuit of the A.V.C. unit is shown in Fig. Q.276.

The R.F. component of the detector plate voltage is passed through a small copper-oxide rectifier instead of the usual detector bypass condenser, and the D.C. voltage thus obtained is utilized to bias the preceding variable-mu R.F. tubes.

Although numerous circuit arrangements are possible the connection shown is of special interest as it indicates the circuit used in a practical delayed A.V.C. system; the delay voltage is obtained from the bias voltage of one of the following tubes, as shown.

ERRATIC VOLUME— FIXED-FREQUENCY OSCILLATOR

(277) Mr. Fred Wm. Lenz, Fayette City, Pa.

(Q.1) I have a radio set which has the tendency to very suddenly and greatly increase in volume when no one is near the set. Reproduction is not undistorted even though the volume seems to go on full-blast, and if left alone the volume will decrease just as it increased with no one near the control. Information as to the adjustment will be very much appreciated.

(A.1) The trouble represented sounds very much like that experienced when an adjacent conductor of large dimensions is altered in its voltage with respect to ground.

This effect may be produced by connecting appliances or electric light bulbs across a circuit adjacent to the radio set or its antenna system, thus producing resonance, or anti-resonance effects. Also, if the load thus put on the line is quite great and the line regulation is poor, the result is quite likely to be a considerable reduction in the power line voltage available at the radio set. A "thermionic" tube, in which one of the elements develops an open circuit due to expansion caused by heat, will produce the same effect.

Thus, the effect may be due to intermittent absorption, reflection, or radiation of the program to which the radio set is tuned. Again, it may be due to signal pick-up by the power line being intermittently fed into the radio set and thus causing an increase or decrease of the signal being heard, depending upon whether the power line signal is in or out of phase with that being picked up by the regular antenna.

The solution in the former case is to relocate the antenna; in the latter, use a line filter consisting of two 1 mf. condensers connected in series; the center-tap is grounded. Connect one of the remaining condenser leads to one side of the power line, and the other condenser lead to the second power line conductor.

If the trouble is due to poor line regulation, a line resistor of the ballast type may be of some assistance.

It is not likely that the set is at fault. However, it may be advisable to check the plate current of each tube, before and during the effect mentioned. Also check the volume control (slider contact and resistance element) since,

in the majority of cases of fading, this unit has been found to be the offender.

(Q.2) Please publish a diagram of a simple oscillator, using an ordinary type 27 tube, which will furnish a steady, fixed R.F. output.

(A.2) A suitable schematic circuit is shown as Fig. Q.277. The condenser shown in shunt to the tuned plate coil may be of the adjustable type. The unit may be adjusted for a given R.F. output and left at the desired setting. A standard 3 circuit tuner may be used provided the assembly is totally shielded; or, an ordinary R.F. coil unit may be used, around which has been wound a pick-up coil having about 5 turns

"NON-POLARIZED" ELECTROLYTIC CONDENSERS

(274) Mr. M. Kowaloff, Philadelphia, Pa.

(Q.) Please explain why it makes no difference whether one side or the other of an electrolytic condenser is connected to the positive side of a power line, provided the electrolytic condenser is of non-polarized type. Although electrolytic condensers are discussed at considerable length in the article, "All About Electrolytic Condensers," which appeared in the September, 1930 issue of RADIO-CRAFT, there is no detailed information on the more modern "non-polarized" design.

(A.) The non-polarized type of electrolytic condenser is connected across, for instance, a D.C. power line as shown in Fig. Q.278. The receiver will operate with the correct polarity only, but the important point about this circuit is that no harm will be done when the line plug is inserted in the reverse position. Ordinary "polarized" condensers would burn out under the same conditions.

Dry electrolytic condensers are normally of the "polarized" type. These condensers consist of 2 aluminum foils, one of which is coated with a film of aluminum oxide "formed" electrolytically on the foil surface. This formed electrode must be connected to the positive side of the circuit for the condenser to function properly. If the polarity is reversed, which results in the unformed electrode being connected to the positive side of the circuit, the leakage current through the condenser will assume extremely large values and damage will be done either to the condenser or to the equipment used in the condenser circuit.

In the ordinary radio receiver, this condition of reversed polarity cannot arise because the polarity of the voltage applied to the condenser is determined by the rectifier tube. Once the

(Continued on page 167)

OVER

1,000 Pages -

The Big Feature of the 1935 Official Radio Service Manual

NO other radio book in history is comparable to the 1935 Official Radio Service Manual. In contents, in style of printing, in grade of paper, in illustrations, there has never been published such a comprehensive volume.

The 1935 Manual will be voted as the most authentic and elaborate service guide ever used in the radio industry.

Service Men who use this new 1935 Manual will be astounded by finding in it such a wealth of profitable service information which has never been previously made available.

FREE! Write for our interesting 8-page booklet, in two colors, which tells the entire story about the NEW 1935 OFFICIAL RADIO SERVICE MANUAL. It's FREE. Simply fill in the coupon below—paste on a one-cent post card, and mail to the publishers.

MAIL COUPON FOR DETAILS

GERNSBACK PUBLICATIONS, Inc., Dept. B
99 Hudson St., New York, N. Y.

Gentlemen: Please send me without delay, a copy of the 8-page brochure, in two colors, giving complete details about the NEW 1935 OFFICIAL RADIO SERVICE MANUAL, and special money-saving offer.

Name

Address

City State

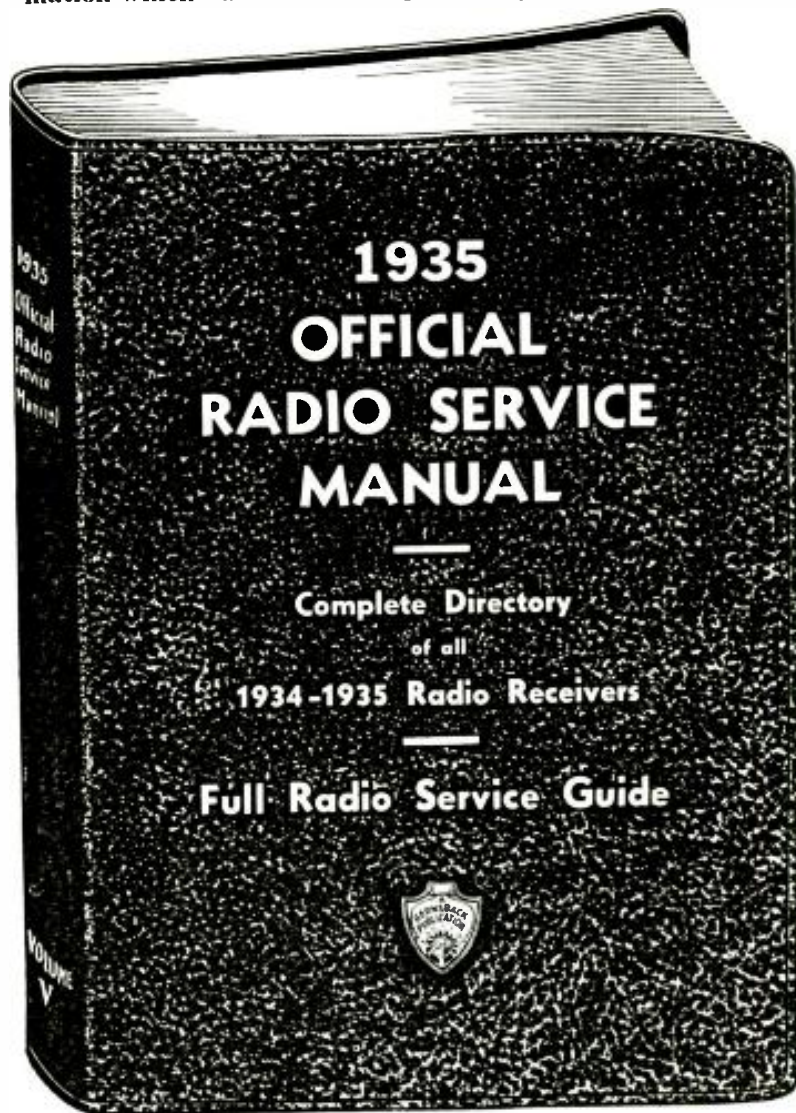

DON'T FAIL TO SEND FOR THE 8-PAGE BROCHURE WHICH TELLS ABOUT THE NEW MANUAL

HOWARD EXPLORER MODEL W 19 TUBE ALL-WAVE SUPER. (Concluded)

tenna trimmer 2. Rotate dial to 3.5 and resonate trimmer 8 at 3,500 kc. Recheck at 8.5 (8.9).

Short-Wave Band No. 3

Turn band indicator to 9 to 21, set dial to 20, and feed in 20,000 kc. Resonate oscillator trimmer 11, R.F. trimmer 4 and antenna trimmer 1. The alignment at 9 is obtained by use of the fixed condensers which should not require change. To insure band sensitivity in the region of major foreign program reception, turn the dial to 12 and resonate antenna coil trimmer 1 at 12,000 kc.

Note that since all adjustments are made with the A.V.C. inactive, extreme care must be used to attenuate the input signal low enough so that there will be no overloading of tube amplifiers while making adjustments.

After these high-frequency adjustments have been made, the service oscillator setting should be advanced 930 kc. and the output signal strength considerably increased; non-reception of the image signal indicates incorrect set oscillator adjustment. For example: a service oscillator signal of 20,930 kc. should be perceptible at 20 on the dial after alignment to 20,000 kc.

Beat Oscillator Adjustments

Turn the main dial to receive a service oscillator signal of 4,800 kc., and make sure that the band on the "beat oscillator" (Frequency Meter V17) falls on 1.5 when the 2 gang condenser is at full capacity.

Turn Osc. Sw. to the right ("Mod."), and frequency dial to 4. Resonate the trimmer on the 2 gang condenser to main dial setting. Turn band indicator switch to short-wave band No. 1 (1.5 to 3.5), set main dial to where 1,500 kc. comes in, turn frequency dial to 1.5, and then resonate trimmer 15.

A.V.C. Adjustment

Connect one side of a high-resistance voltmeter to A.V.C. potentiometer terminal which connects to the "high" side of the 0.2-meg. resistor and to the 0.1-mf. fixed condenser, and the other (positive) to chassis ground.

Adjust the receiver for reception of a signal intensity of 3,000 to 4,000 microvolts, and vary for maximum voltmeter reading, in a given locality, the adjustment in the top, next to the neon adjustment, of the coil can assembly in the upper right-hand corner (facing rear of tuner).

In certain localities close to a broadcast station it may be necessary to readjust the A.V.C. (slotted shaft) control. Exactly resonance the receiver. Then, if the station's signals sound "fringy" or rough, turn the control to the right only sufficiently far to correct this condition.

Neon Tuning Indicator and Q.A.V.C.

Facing the back of the tuner chassis, extending through one of the tall shielded assemblies in the upper right-hand corner, will be found a small, black knurled knob used to adjust the neon resonance indicator. It is advantageous to be able to set this adjustment if excessive fading is experienced due to locality. Adjust the receiver dial to a powerful station during the time of day in which it is received strongest. Then turn the neon adjustment until the light just fills the opening in arrow dial. Readjust the tuning dial of the receiver; should the light become more brilliant, leave the dial at the point of highest brilliancy and again readjust the neon indicator until it just fills the arrow opening. (This adjustment need be made only when the set is installed.)

Since the inter-station noise suppression system or Q.A.V.C. is a proportional function

of the neon light, the Q.A.V.C. system will be correctly adjusted.

Note that the neon light system is not intended to work on the short-wave stations. However, it will usually indicate resonance to more powerful signals.

Resistor X is an oscillator suppressor in short-wave band No. 3. Its value is determined by individual requirements.

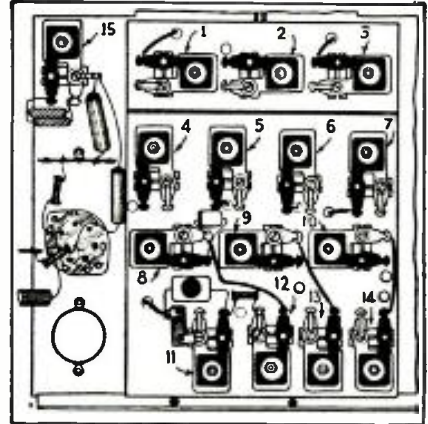

Locations of trimmer condensers in the new 19 tube all-wave superheterodyne. This illustration furnishes the necessary information to complete the data in the text.

Schematic circuit of the tuner chassis. There are 10 tubes in this unit. The 2-gang condenser mentioned in the text is located at the right of oscillator V17.

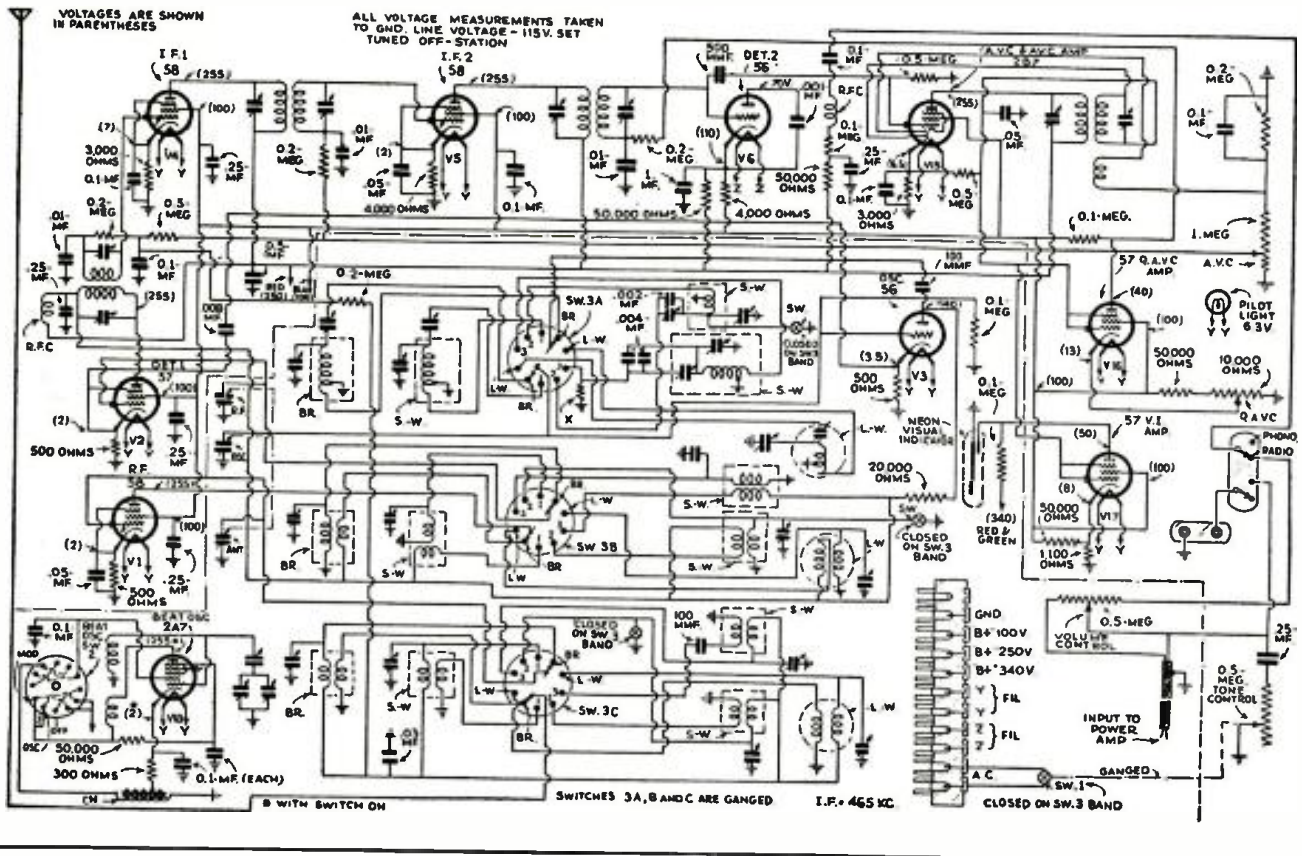

INTERNATIONAL RADIO REVIEW

(Continued from page 147)

DEMOUNTABLE TUBES

IN A recent issue of *TOUTE LA RADIO* some interesting facts concerning transmitting tubes were presented. These tubes which cost a great deal more than the small types used for receiving are generally repaired when the filament burns out or when some other defect presents itself since these repairs are economically practical although they require the use of a skilled technician and glass blower.

Professor F. Holweck a French scientist has been working for some time on the design of such tubes the "repairing" of which is easily facilitated due to their special construction. Several of these tube types are shown in Fig. D. As you will note, they are composed of individual units of metal and quartz glass upon which the various tube elements are mounted. These parts fit together very tightly so that there is no possibility of an air leak, and each tube is equipped with a molecular type of vacuum pump so that it may be "hardened" from time to time during its service life. Repairs with these new tubes are much more simple and no difficult glass blowing is required to reassemble them.

THE "MUSHROOM" HORN

THE Telefunken Co., a well known German electrical and radio manufacturing concern, has just developed a new type of sound reproducer which is receiving a good deal of publicity in European magazines.

This new speaker which at first seems to have some interesting features proves a disappointment on further analysis, when it is discovered that the same action can be achieved in a much more simple manner.

The "mushroom" speaker, as this new unit is called, uses a moving coil driver movement and directs its sound upwards by means of an exponential horn, mounted within another horn of the exponential type which reflects the sound downward and sprays it in all directions. This can be readily seen in the photo, Fig. E, which appeared recently in *WIRELESS WORLD* magazine. The space between the projecting horn and the reflecting bowl (horn) is also exponential in curvature so that no distortion of the wave form occurs. The advantage of this speaker over common methods is in the equal distribution of sound in all directions, the absence of echo effects, and economy.

It will be easily understood, though, that a similar spray action can be duplicated by the simple expedient of mounting a single exponential horn with the "bell" facing downward so that the sound is projected toward the ground and then sprayed out in all directions from a point directly below it.

A VISUAL TUNING INDICATOR

THE development of automatic volume control and sharply tuned superheterodyne receivers have brought into the "lime light" a number of devices for indicating true resonance. The device shown in Figs. 2 and F is an English version of a tuning indicator recently described in *AMATEUR WIRELESS* magazine. While working on an entirely different principle from the neon light column indicator, it supplies tuning indication in very much the same manner as the neon light beam indicator.

The detail drawing, Fig. 2, shows the construction of the device which is connected in series with the plate supply lead for the intermediate frequency amplifier. An oil filled tube containing two triangular metal segments is supported in a strong magnetic field, the intensity of magnetism being controlled by the current flowing through the solenoid. One of the triangular segments floats in the cylindrical tube, and the position of this "shutter" controls the length of the triangular opening between the two opaque segments.

Thus, when a station is tuned in, and the plate current of the I.F. amplifier changes, the electro-magnet pulls the opaque triangular segments around, thus reducing the opening between them and making the triangle of light shorter.

Weston scores again!

WITH A NEW TUBE CHECKER

\$ **29** ²⁵/_{Net}
WITH EITHER
COUNTER OR
PORTABLE CASE

The new Weston Model 682 Tube Checker, priced sensationally low for a quality in-

strument, is a combination servicer and merchandiser. Attractively finished in colors and with a scale with a "good tube" area, it makes an appealing and convincing counter

merchandiser when mounted in the counter type case. For field servicing, the instru-

ment can be slipped into a leatherette carrying case. Other features make Model 682 the outstanding value in tube checkers today. Here are some of them:

1. Attractively finished in two tones of fawn with silver edging.
2. Instrument can be used as counter merchandiser or portable checker.
3. Counter type case at "easy reading" angle.
4. Single arc scale shows good tubes as "good."
5. Tests tubes commercially used today. Spare sockets for future tubes.
6. Line voltage control.
7. Short check for 4, 5, 6 and 7 prong tubes.
8. Tests cathode leakage by operating switch.
9. Individual tests on all plates of rectifier tubes.
10. "On" and "off" switch.
11. Simple to operate—only one setting of indicator necessary.



Panel view of Tube Checker

Be sure to see this low-priced Model 682 at your jobber's today, or write for information . . . Weston Electrical Instrument Corporation, 599 Frelinghuysen Avenue, Newark, N. J.

WESTON
Radio Instruments



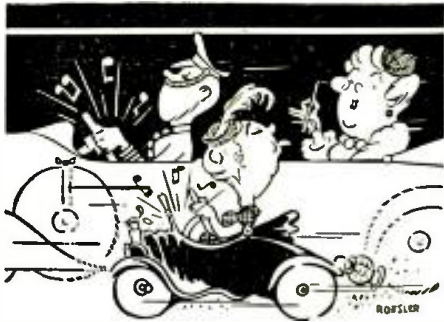

"The Colonel's Lady and Judy O'Grady"

may or may not be "daughters under the skin" — but it's a sure bet that their auto radios function equally well . . . that is IF they are equipped with Centralab Suppressors. For Centralab suppressors work mighty well against the asthmatic wheezings of a decrepit college car of early vintage — and they do a real job filtering out the umpty-umph horse-power impulses of a sixteen cylinder Rolls-nice.



CENTRAL RADIO LABORATORIES
Milwaukee, Wis.

Centralab
CENTRAL RADIO LABORATORIES
MOTOR RADIO NOISE SUPPRESSORS

A Radically new Tube Tester!

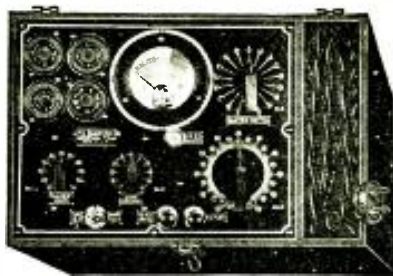

Model 22

This instrument tests all present day tubes AND due to use of rotary switch and variable SHUNT allows the addition of new tubes without removing from ease. It tests the 2nd plate of all tubes. DIRECT reading on shaded dial. Allows diode and triode tests to be made separately. 3 1/2" D'Arsenal meter, 2% accuracy. NEON leakage and short test AUTOMATIC and test for short or leakage covers all elements. Accurate line voltage regulation allows uniform readings. Plate and filament both controlled. AND provisions are made so that condensers .00025 to 5 M.F. can be tested for leakage-short-good. Likewise, resistance can be measured through meter scale is not calibrated for this purpose. Vacuum tube voltmeter principle is used for this test. Portable. Top cover not shown in illustration above. Verichrome lettered bakelite panel. Dealers and Servicemen, \$23.75

10 days trial—money refunded if not satisfactory.

L & L ELECTRIC COMPANY

336 MADISON AVE. Dept. 12-A MEMPHIS, TENN.

AUTO ANTENNA COUPLING SYSTEMS

(Continued from page 157)

the chassis. Striking would produce loud clicks in the speaker.

It is common practice for us to filter the dome light circuit, where a roof antenna is employed. Very few of us realize that the tail-light should be similarly filtered when an under-car antenna is employed. It goes a long way toward solving the old ignition noise trouble.

While the running-board type of under-car aerial has found a certain amount of popularity, it suffers by comparison with either of the other types, both from the standpoint of pick-up and mechanical frailty as well as its susceptibility to injury from contact with road obstructions or curbstones.

Antenna Coupling Systems

In general, there are 4 distinct methods of coupling the auto antenna to the receiver. This is true regardless of the type of aerial employed. For the sake of comparison, let us see what happens with each type, when used in conjunction with the best type of auto antenna, namely: a roof aerial in a sedan.

(a) The use of ordinary, heavy wire, with good insulation but no shielding, is a common system in the older types of cars and some of the new ones. In this case, the lead-in is actually a part of the aerial and provides additional pick-up. However, it usually passes in the vicinity of the electric light or ignition wiring, with the result that the elimination of interference is somewhat difficult. As far as signal pick-up is concerned, this system may well be used as a basis of comparison with the others.

(b) In order to simplify installation and reduce ignition interference, it has become common practice to replace the ordinary wire with a shielded conductor. The latest instruction books for Service Men, such as the excellent compilation of auto-radio service notes which has been made available, without charge, by Sylvania (and obtainable, also, by writing this magazine for a copy) recommend that the outside shield of this conductor be grounded.

Grounding this shield results in an average loss of 4 decibels, over the entire range of the receiver. With a sensitive receiver, this loss is not important. With an insensitive receiver it makes suitable reception over long distances a practical impossibility. It is a rather unhappy compromise.

(c) In order to offset the losses (see Fig. 2) which system (b) is bound to introduce, auto-radio receiver manufacturers and the more progressive Service Men have begun replacing the ordinary shielded wire with a rather thick cable, in which the center wire is separated from the outside shield by a cotton or fibre filler. The purpose of this type of wire is to offset the capacity in the wire; this goes a long way toward overcoming the losses introduced by the (b) method. It must be borne in mind that system (c) can never equal system (a), because it is practically impossible to eliminate all the losses which the shielding introduces and, so far as actual pick-up is concerned, the heavy wire does not become an actual part of the antenna—the pick-up is limited to the roof aerial itself. Of the 3 systems, however, it will be found that the average of many cars and many receivers will prove system (c) the best of the 3.

(d) An entirely new system, having all the noise-reducing properties of (b) and (c), as well as showing a marked increase in signal strength over all 3 systems thus far considered, is made possible by the use of a shielded transmission line and a pair of impedance-matching transformers. By matching the impedance of the antenna against the shielded lead, at the antenna, and then matching the shielded lead to the input impedance of the particular receiver in use, produces surprising results. It is worth noting that the better the antenna the more pronounced this improvement will be.

Reference to the accompanying graph, Fig. 2, will illustrate the performance of systems a, b, c and d, under the same conditions. System (a) is indicated by the 0 reference level. System (b) is shown as being 4 db. lower in pick-up, throughout the entire range and system (c) is shown as 1/2-db. below system (a).

It will be observed that system (d) shows an average gain of 4 db. above system (a); 4 1/2 above system (c), and 7+ over system (b).

The graph has been made from actual measurements of systems a, b and d, while system (c) is a computation. As explained above, it would be a practical impossibility for system (c) to be as good as system (a), as far as sensitivity is concerned.

As system (d) is very easy to install and may be had at a very reasonable price, it may be employed to simplify installations as well as greatly reducing the interference elimination problem, regardless of the type of antenna employed.

Recommended Auto Radio Antennas

First and best—a good roof aerial coupled with a hi-gain, impedance-matching transmission line to the receiver.

Second—a choice between a good roof aerial and system (a) or (c) or an under-car aerial of the triangular type used with system (d).

Third—a running-board aerial with system (a). System (d) will not work well with a running-board aerial.

Important. The devices, now on the market, for use in applying system (d), comprise an antenna transformer, 10 ft. of R.F. transmission line of the shielded type, and a receiver transformer. It is important to note that some receivers, such as the new Motorola, have a low-impedance input circuit, which is nearly a match for the shielded lead. In this case, the receiver transformer is not used. The antenna transformer is always used and it is left to the discretion of the Service Man to ground the shielded cable or not. The best results, determined by experiment, indicate the answer.

A NEW REMOTE CONTROL UNIT

(Continued from page 156)

attached to the receiver may be turned to tune in a station or to change the volume level.

The comparatively low price of this unit and the simplicity with which it is attached make it attractive for use with table sets and midgets as well as with large consoles.

Fig. 2. Graphic representation of comparative antenna-system efficiencies.

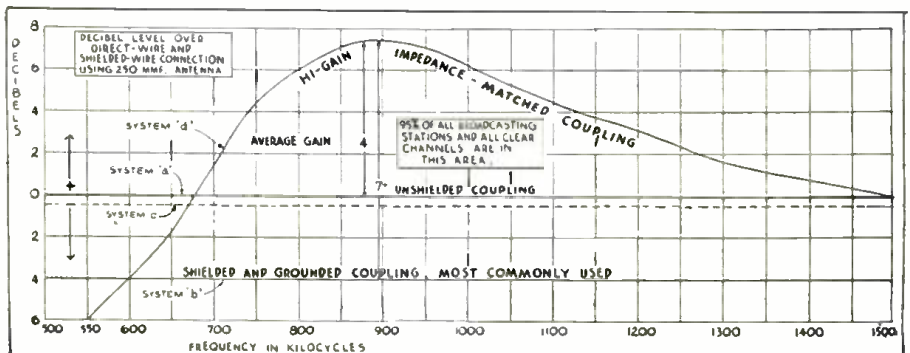

INFORMATION BUREAU

(Continued from page 162)

condenser is connected into the circuit properly. at the factory, there is no danger of reversal during use.

In the case of a D.C. receiver not using a rectifier tube, this automatic protection does not exist. If the line plug is reversed when inserted in the power line socket, the polarity of the voltage applied to the condenser can be in the wrong direction for proper operation.

In order to meet this condition the non-polarized type of condenser was devised. Both aluminum foils comprising the electrodes of this condenser are formed. Either electrode may then be connected to the positive side of the circuit, as shown in Fig. Q.278, without high values of leakage current resulting.

This type of construction is not used universally because it is necessary to use twice the foil area on each electrode in order to secure the same capacity as with the polarized type. This follows because each foil acts as a condenser and both are in series resulting in an effective capacity of half that of each individual condenser.

The cost of a non-polarized condenser of a given rating is, therefore, practically the same as that of a polarized condenser of half the capacity and the same voltage rating.

Since non-polarized condensers may be used independently of circuit polarity, they may be used on A.C. At the present state of the electrolytic condenser art, these condensers have proved practical only for *intermittent* use at 110 or 220 V. A.C.

As an illustration of such application, non-polarized condensers are being used quite generally in connection with A.C. motors for starting purposes.

Solar Mfg. Corp.

WATTS DISSIPATION

(279) Mr. Ira Ashcroft, Claremont, N. H.

(Q.) How is the figure for "watts dissipation" determined, and how does it compare with the watts rating of a resistor?

(A.) Many people have only a very vague conception concerning the relation between the "watts dissipated" by a resistance unit and the temperature attained by the unit. One of the first laws of physics tells us that no energy can be lost—it must be used up or dissipated either in its original or some other form. In the case of a resistor, the electrical energy lost in the unit must be turned into heat and dissipated.

Figure Q.279 shows a resistor operating at full load, that is, its full "watts rating." The thermometer shows that the temperature at the center (the hottest point) is about 520 degrees F. and that at the ends is about 260 degrees F. These temperatures are based upon the unit being in open air at a room temperature of 70 degrees F.

It is obvious that if this resistor were to be enclosed the temperature would quickly build up to a much higher point. Therefore, the watts dissipated by the unit must be reduced when the resistor is enclosed; usually it should not be made to dissipate more than one-half of the rated watts when the circulation of the surrounding air is at all restricted. It should also be kept in mind that a resistor which is dissipating heat should not be placed in close proximity to any piece of apparatus which might be affected by the heat.

When selecting resistors GREAT CARE SHOULD BE TAKEN TO GET UNITS WHICH ARE LARGE ENOUGH FOR THE APPLICATION ON WHICH THEY ARE TO BE USED and also to get high quality units which will stand not only the heat generated but also the alternate heating and cooling to which the unit may be subjected in service.

(Ohmite News)

SUPER-AUDIBLE SOUND

(280) Mr. Ernst Smith, Lowell, Mich.

(Q.) The following is a quotation from a newspaper item in which it was stated that



"X" generally stands for the *unknown* . . . for something that is present, but unseen. You can compare it to the hidden character that makes one paint last longer than another, one suit of clothes give better service than another, one kind of marble stand up better than another which *looks the same*.

It is the "X" quality in Raytheon 4-pillar Tubes that makes them the chosen tube for polar expeditions, for the nation's largest air transportation companies, for police departments throughout the land, for automobile radios and for millions of private set-owners.

You can attribute the longer and better service of Raytheons, of course, to the 4-pillar principle. But it goes even deeper than that. It goes down to the "X" quality. And the nearest you can come to explaining that is by calling it *the integrity of their manufacture*.

For Raytheons are manufactured by craftsmen steeped in the watchmaker's tradition. That's why all their elements are precisely aligned . . . and kept precisely aligned by the patented 4-pillar support-principle.

And that's why Raytheon 4-pillar Tubes can be used with confidence and utmost satisfaction in almost any circuit, and why you can recommend them without reservation. Your word is protected — by the "X" quality!

RAYTHEON PRODUCTION CORPORATION

30 E. 42nd St., New York City

55 Chapel St., Newton, Mass.

445 Lake Shore Drive
Chicago, Illinois

555 Howard St.
San Francisco

RAYTHEON

TRADE-MARK

4-PILLAR RADIO TUBES

HEADQUARTERS FOR PUBLIC ADDRESS AMPLIFIERS
BUY DIRECT from MANUFACTURER and SAVE BIG MONEY!

UNIVERSAL PORTABLE 6-VOLT P.A. SYSTEM

(May be operated from 110 Volts A.C. as well!)

Produces 13 Watts of Undistorted Audio Output!

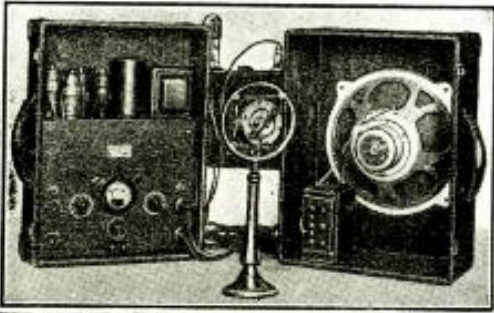

Features a self-contained Universal Input Control Panel (for mixing and fading all input signals), 11" Dynamic Speaker (separately removable from the amplifier) as well as convenient facilities for storing a microphone, microphone stand, extension cables, etc. Input connections are provided for a double button microphone (100 or 200 ohms per button) phon. pickup or line (of the following impedances: 5,000-3,000-800-600-200 or 67 ohms) as well as for a radio tuner, crystal microphone or crystal photo pickup. Extremely simple to operate. Easily installed anywhere.

Write for our almost unbelievable low price on this equipment!

FREE 100-PAGE RADIO AND AMPLIFIER CATALOG.

Completely describes our new line of 1935 Amplifiers (52 models!) as well as All-Wave and Short-Wave Receivers and Converters, Inter-Office Call Systems, Test Equipment, Replacement Parts, Kits, Tubes, and Accessories—all at unbeatable net prices. Send for your Copy!

Coil Letter	Wavelength in meters
A	13 to 26
B	25 to 55
C	52 to 110
D	94 to 270
E	200 to 545
F	500 to 1,500
G	1,000 to 3,000

A total of 4 tubes is employed in this receiver, but 5 tube efficiency is obtained because of the "composite" functions of the 6F7 tube, which performs as a combined R.F. (pentode section) and first A.F. (triode section) tube. This is followed by a 77 which serves as the detector, and a 43 which is the power audio stage. A 25Z5 tube is employed as a half-wave rectifier (on A.C.) but the receiver will operate on either 110 V. A.C. or D.C. A dynamic speaker, constructed as an integral part of the receiver chassis, insures good quality reproduction.

HOW TO MAKE A GRID DIP OSCILLATOR

(Continued from page 154)

Oscillator to a marked degree.

The transformer of a discarded trickle-charger was pressed into service, with pleasing results. In Fig. 3 we see how this was accomplished. The 25 V. or 30 V. (no load) delivered by the secondary was admirably suited for the filament and plate requirements of the tube. It was also found possible to light a pilot lamp from the same supply. This is a worthwhile addition to the circuit, since it provides a means of visibly indicating when the instrument is "on." Another advantage of using a transformer, which might be mentioned here, is that it makes possible the grounding of one side of the filament, without danger of short-circuiting the A.C. line.

As previously stated, the entire oscillator is mounted in a metal box. In addition to this, in order to avoid body capacity effects, it is advisable to insulate the condenser shaft from the dial with an insulating coupling. The distance between the condenser and the panel should be about 2 ins. The photographs show the placement of the remaining components.

The 50 mmf. coupling condensers, C1 and C2, may be either midget variables, or of the trimmer condenser type. Two coupling condensers are used, rather than one, in order to provide loose coupling between oscillator and set at the high frequencies, and tight coupling at the low frequencies, without the necessity of continual readjustment of the condensers. The shorting switch shorts out one of the condensers when close coupling is desired, and throws it back into the circuit for loose coupling.

The coupling is adjusted so that the milliammeter needle drops gradually to a minimum value, and comes up again just as gradually, in accordance with the movement of the dial, when the apparatus is connected to the tuned circuit under test. If the needle shows a tendency to snap back suddenly, after dropping to a minimum value, it is an indication that the coupling is too tight. This is readily corrected by adjusting the coupling condensers.

In order to balance the R.F. system of a radio set with the grid-dip meter, the instrument is plugged into the A.C. line, and the "Ground" and "Grid" terminals are connected, respectively, to the ground post of the set, and the control-grid of the first R.F. tube. Be sure the set is not plugged into the line, and that the volume control is on full.

Now set the oscillator dial at about 20 deg., and adjust the tuning dial on the set until the milliammeter needle dips to the minimum position. Without disturbing this adjustment, move the grid clip to the control-grid of the next R.F. tube. Now set the trimmer condenser of this circuit until the needle again dips to a minimum. Repeat this procedure for the remaining R.F. stages. Now check the set at one or two other points along the dial, say, at 50 and at 90.

In addition to balancing the R.F. end of a set, the grid-dip oscillator may be used to check the audio system. The instrument generates an oscillating current, which is modulated by the 60-cycle line frequency. The output of the oscillator, when fed into the antenna and ground terminals of the set, is amplified, and reproduced by the speaker. When there is no broadcast program to test the set on, as during an S.O.S., the grid-dip meter is a reliable substitute.

HELPS - YOU - TO - Earn Big Money!

OFFICIAL P.A. AMPLIFIER MANUAL AND SOUND SYSTEM TREATISE

Devoted Exclusively to the Problems Involved in Purchasing, Designing, Measuring, Testing, Installing, Operating, Troubleshooting, Maintaining, and Money Making Possibilities of Public Address Systems. A vital necessity to everyone connected in any way with Sound Systems—Public Address Work—or Amplifiers—and Associated Equipment! Complete and Authoritative!

Contains 64 Pages 8" x 10 3/4", Over 150 Diagrams, Charts and Illustrations.

\$1.00
POST PAID

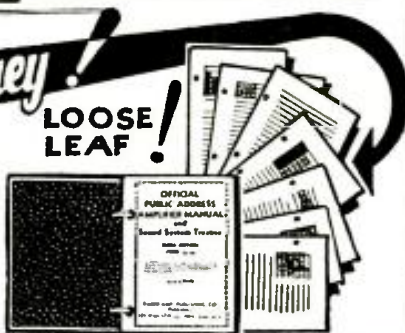

COAST-TO-COAST-RADIO-CORP.
123 K. WEST 17TH STREET, NEW YORK, N.Y.

Professor Larsen of Oslo, Norway, had devised a special microphone that would make insect noises audible to the human ear by amplification through a loudspeaker: "Insects 'converse' in notes so high that the human ear cannot hear them—but the super-sensitive electronic tube can do so and amplify them to audibility."

I would like very much to know how this is accomplished.

(A.) We are advised by Rolf Schnell-Larsen, who is not a professor but a technical student, as follows:

"As to my own apparatus I must advise you that you are misinformed. The experiments do not aim at detecting and reproducing the super-audible frequencies of insects, but on the other hand to examine their flight.

"To be sure I did make some experiments with a microphone and accompanying amplifier equipment, and found some sounds among the insects that are not audible in general, but they were not of any super-audible frequencies.

"The exploration of the flight of insects for instance is performed by finding their flying-rate-of speed per second, their number of wing-beats per second, and the dependence of these numbers on each other; as well as their dependence of the flying direction the insects have in connection with the horizontal plane. We can, by repeating the experiments and varying the temperature of the surroundings or their color, and by studying the variation these produce on the flight, come to a conclusion about the reaction of the insect to warmth and color."

POWER PUNCHER

(281) Mr. N. Byron Apple, Columbus, O.

(Q.) In the June 1934 issue of RADIO-CRAFT, in the International Radio Review department, was described a "power puncher," a device for economizing on "B" battery consumption. Is there any possibility that the circuit of this instrument is available?

(A.) The schematic circuit of the power puncher is shown in Fig. Q.280. It will be seen that part of the A.F. output from the power stage is rectified and a portion on the D.C. voltage so obtained is applied in series with the fixed bias to the output tube.

Essentially the output tube is over-biased, thus reducing the plate current, and since the additional bias obtained from the economizer unit opposes the fixed bias, this reduces the bias voltage when a signal is applied, resulting in an increase of the plate current of output tube V. Thus, the output tube functions as a class B amplifier.

(Continued on page 181)

ALL-WAVE A.C.-D.C. SET

(Continued from page 157)

A total of 7 coils is employed to cover the various bands ranging from 15 to 3,000 meters. Each coil is fully marked and easily identified for its respective coverage. The coils are of the 5 prong construction type, and are labeled as follows:

Rear view. Plug-in coil is shown at left.



UNIVERSAL 6 V. P.A. SYSTEM

(Continued from page 166)

verter rectifier unit to be instantaneously switched "ON" and "OFF" without shutting off the filament supply. Power consumption is further reduced by using an unusually efficient self-contained "B" voltage converter-rectifier unit, together with a class B power output stage, employing the type 79 tubes specifically designed for this purpose.

The entire P.A. system is housed within a 2-section leatherette-covered and reinforced sturdy wooden portable case measuring 13 1/4 x 17 1/4 x 1 1/2 ins. deep, and weighing in all only 3 1/2 lbs. The loudspeaker itself is mounted on the cover which also acts as an excellently proportioned and effective baffle box. It is provided with "come-apart" hinges, to permit the ready removal and placement of the speaker case at a considerable distance from the amplifier. The dynamic speaker cone is fully protected by a sturdy wire screen. A removable metal cover and wing nuts are also provided to cover the speaker opening during transportation. A 50 ft. extension cable permits the loudspeaker to be placed at any convenient distance from the amplifier. (Of course, additional standard 5 wire speaker extension cables may be employed to further increase the distance between the amplifier and the speaker.) A universal output transformer is mounted into the same case, to permit the use and proper matching of any number of additional speakers. (When employing this system for 110 V. A.C. operation, the speaker field is connected to an appropriate 110 V. A.C. exciter that produces 6 V. D.C. at 1 1/2 A.)

The amplifier proper and the universal control board are housed in the other half of the portable case, as seen in Fig. 1. The chassis is so arranged as to permit easy accessibility to all tubes, while their recessed placement offers them a natural protection against accidental breakage. All operating controls and switches are located on the front side of the chassis, and form a complete, fully effective and universal control board.

Control Circuits

As distortion-free pad type volume control potentiometers are employed, phono., or radio and microphone input signals may be fully controlled independently from each other. Any one signal may be "mixed" with any other, or it may be used as an effective "background" for any desired program. A tone (and feedback) control and a pilot indicator bulb are also included. As may be seen from the schematic diagram, the microphone current is automatically supplied by the amplifier both on 6 V. battery and on A.C. operation.

It is imperative to filter by means of a choke and a condenser, the microphone current obtained from the storage battery, in order to eliminate electrical disturbances caused by the ignition and associated circuits—a precaution

too often neglected. The battery and A.C. operation selection switch selects the microphone current supply either from the storage battery or from the filtered high D.C. voltage of the A.C. power pack through a suitable resistance. Note that a stabilizing resistor is included to prevent excessively high voltages from being applied to the microphone buttons. This precaution guards against injury to the microphone under any condition of operation. All facilities for connections to and from the amplifier are conveniently provided for on the front control panel of the amplifier chassis.

Input Connections

Input connections are provided for a double-button microphone (100 or 200 ohms per button), a phono. pickup or line (having any one of the following impedances: 5,000, 3,000, 800, 500, 200 and 67 ohms), as well as for a radio tuner, crystal (piezoelectric) microphone or crystal phono. pickup.

The corresponding input transformers are mounted at the bottom of the chassis directly opposite from the power transformer, which is seen mounted on the top, next to the converter-rectifier unit. This placement of vital units eliminates all possibility of hum pickup.

The overall gain of this amplifier is more than sufficient to permit the production of 13 W. audio output regardless of the low-level input signal source with which it may be used. Full power output is obtained with any crystal or electromagnetic pickup. Pre-amplifiers are not required for use with crystal microphones!

This complete system is easily capable of adequately covering 2 to 3 city blocks depending upon the number and type of additional speakers employed as well as the street noises of the district.

List of Parts

One Coast-to-Coast dual-section leatherette-covered (reinforced wood frame) amplifier and speaker case;

One Remington 11 in. dynamic 6 V. speaker and 50 ft. extension cable;

One Remington all-purpose microphone stand; One Remington double-button microphone and 50 ft. extension cable;

One Remington universal output transformer type D2395B, T4;

One Coast-to-Coast drilled metal chassis, size 10x12x3 ins.;

One Remington universal phono. input transformer type T1E673, T1;

One Remington double-button microphone transformer type D2317, T2;

One Remington class B input transformer type D2351, T3;

One Remington converter-rectifier power transformer type PTE673, P.T.;

One Coast-to-Coast converter-rectifier unit, delivering 75 ma. at 265 V., Conv. Rect.;

One Remington kit of resistors, condensers, miscellaneous hardware, blue prints, etc.

Complete schematic circuit of the Universal 6V. P.A. System.

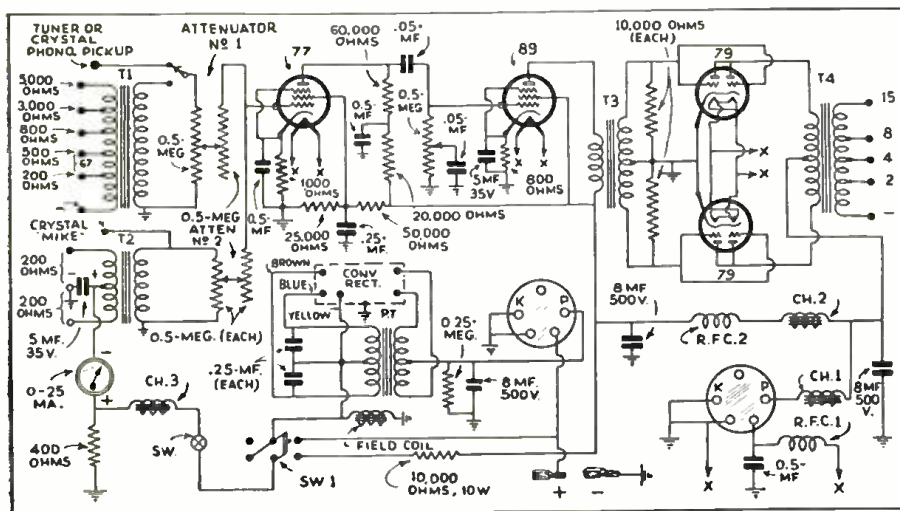

ANNOUNCING

Two NEW and
BETTER
Tube Testers!



Readrite
NOS. 421-422

READRITE announces two new and better tube testers: the No. 421, for the dealer's counter—and the No. 422, a portable unit for the service man . . . out in the field. These improved testers are characterized by many unusual and outstanding features that give a new conception of tube tester performance. They are so simply designed that anyone, without experience, can operate and understand them.

These testers incorporate a 3 1/2" Triplett Precision Meter, which has a shaded two-color scale. It indicates in simple English that the condition of the tube is either "good" or "poor." No longer need you reassure skeptical customers as to the worth of tubes that you are testing for them.

A line voltage control A.C. Meter is incorporated. Cathode and grid shorts are also tested. A simple push button provides two-plate current readings for determining the worth and conductance of all types of new and old tubes.

Your Jobber Can Supply You

. . . with the No. 421 (counter tester) at the dealer's net price of \$24.00—and with the No. 422 (portable tester), at the dealer's net price of \$25.50. These testers come in a beautiful quarter-sawed oak case.

READRITE METER WORKS

124 College Ave.

Bluffton, Ohio



SEND COUPON FOR FACTS!

READRITE METER WORKS,
124 College Ave.,
Bluffton, Ohio

Gentlemen:

Send me a catalog on Readrite Tube Testers, and your complete line of radio servicing equipment.

Name

Address

City State

The **TOBE** Condenser Analyzer

A POSITIVE—SIMPLE—AND INEXPENSIVE SOLUTION OF SERVICEMEN'S CONDENSER PROBLEMS AND TROUBLES!



Use this instrument to indicate the condition of any condenser—of any capacity—of any type—electrolytic, paper, mica, and oil.

- Indicates poor, leaky condensers of relatively low D.C. resistance and high current leakage.
- Indicates condensers that operate intermittently.
- Indicates "OPENS" and "SHORTED" condensers.
- Identifies all condensers as "SATISFACTORY" or "REPLACE."
- Tests at voltages up to 700 volts, D.C.

Has many other uses in radio and electrical service.

Obtain a **TOBE** CONDENSER ANALYZER Today

from your Distributor or direct from the factory. (Allow postage on six pounds.)

Net Price to Serviceman or Dealer Only **\$11.40**
Price \$11.70 in Denver and the West Coast

TOBE DEUTSCHMANN CORPORATION
CANTON, MASS.

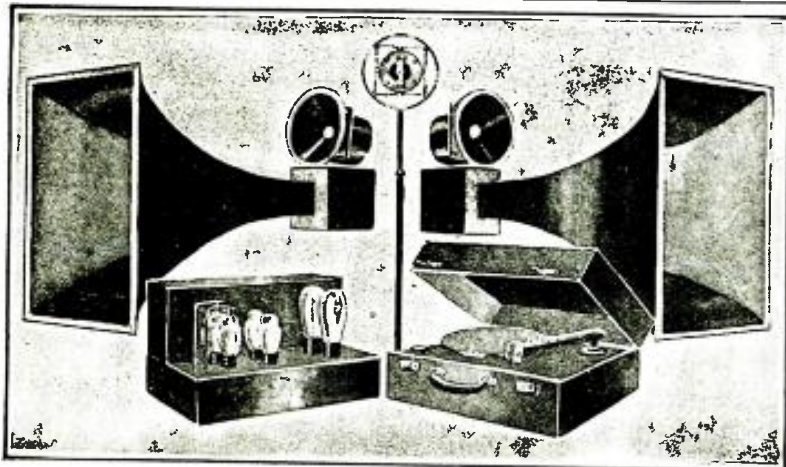

**C
O
M
P
L
E
T
E**

6 Volt Amplifying System

Complete 15 Watt Ballyhoo System for Cars, Trucks, and Tent Shows. Operates from storage battery. Net Price ~

25% with order, balance C.O.D.

\$119.50

Send 3c for 1934 catalogue listing hundreds of public address items.

RADIO AMPLIFIER LABORATORIES

291 E. 137th Street

New York City

for SPEAKER REPAIRS



The **EVEREADY SERVICE CEMENT** is specially prepared for cementing new cones and spiders on dynamic speakers, for reuniting rattling cones, cementing loose tube bases, grid caps to glass, supporting coils, leads, sealing adjustments, etc. It is non-inductive, fast drying, water proof and vibration proof. List price 50c.



The **R-S SPEAKER SHIMS** are necessary for the proper centering of voice coils on dynamic speakers. They are made of flexible steel, and four sizes are furnished in a handy leather case. (16 shims in all) color coded. List price 65c.

The **R-S 5000 VOLT INSULATING CAMBRIC**. Insulating material is a handy item to have in a service shop. It is used for insulating and preventing grounds and shorts on field coils, transformers, resistors, condensers, wires, etc. Rolls of over 200 sq. in. List price 50c.

The **EVEREADY SERVICE SOLVENT** can be used to loosen and remove old cement from cones, to thin the cement and to clean wire wound volume controls, spring contacts, etc. List price 25c.

Buy from your jobber—If he cannot supply you write us.
GENERAL CEMENT MFG. CO. Rockford, Illinois

NEW!!

VACUUM TUBE MANUAL

A 104-PAGE booklet has just been released by Hygrade Sylvania Corporation relating to fundamental theory and complete characteristics of all present-day radio tubes. It is chock full of data, individual consideration being given to every tube that has an application to radio.

Also included are data pertaining to Fundamental Properties of Vacuum Tubes, Definitions, Amplifier Classification, Volume Control Considerations, Shielding, etc., etc.

This book may be obtained through **RADIO-CRAFT** magazine upon receipt of 10c to cover mailing costs. Ask for book No. 538.

THE LISTENING POST

(Continued from page 152)

be on early. This was broadcast over the I.D.A. chain of 'tip' stations. A new addition is KDKA and W8XK in Pittsburgh, Pa. They broadcast world-wide all-wave DX tips for the I.D.A. each Sunday night from 11:30 P.M. to midnight on 980 kc. and 48.8 meters, for 15 minutes or longer. If the response is great enough, KDKA will continue these broadcasts."

It is requested of all readers to listen to these DX tips and at least drop a postcard to KDKA requesting that they continue these broadcasts. Other stations included in the I.D.A. chain are the following: KFOX—2:50 A.M. Eastern Standard Time (11:50 P.M. Pacific Standard Time), Sunday Mornings. KFOX is located in Long Beach, Cal., on 1,250 kc. WDAF—1:25 A.M. Eastern Standard Time (12:25 A.M. Central Standard Time), Sundays. WDAF is located in Kansas City, Mo., on 610 kc.

And from Charles Meyer, Jr., 411 Blake St., St. Joseph, Mo., we receive an interesting letter: "I caught CX26 (Montevideo, Uruguay) on their I.D.A. broadcast—about R3 and QSA4. Guess you had them at about R7 or 8 (Nope—you were luckier than I this time, Charles). I've been hearing queer-sounding stations on 820 and 850 kc. What could they be?" Well, you've possibly been hearing 1YA in Auckland, New Zealand, and 2BL, Sidney, Australia. Congrats! Those are good catches—according to "Tune-In."

Bob Pybus, 57 Highfield Road, Chlorton-cum-Hardy, Manchester, England, has sent a most interesting letter about DX-ing in England.

"In England we are not permitted by law to have aerials over 100 ft. long or 100 ft. high. That makes it difficult for us to catch up to you fellows with aerials 1000 ft. long. Our ultra-broadcast wave (550 to 2,000 meters) stations are harder to get than any American station, and their only advantage is the better daylight range. Our regular American stations are WCAU, WPG, WTIC, and the northeastern American stations." Bob sends some valuable data on European stations which are hard to get. Thank you, friend, so many miles away!

And just as far to the south, a communication emanates from Professor Louis S. Hernandez, Liceo de Aplicacion, Cassilla 3375, Santiago de Chile. The professor sends an up-to-date log of South American stations with their transmitting hours. He informs us:

"The prefixes of the Chilean call letters have been changed. They are C-E—pronounced *Cay-Ay*—followed by the numbers of the frequencies with the last cipher removed." A more recent list received from Buenos Aires shows them to be 4 letter calls with CMA or CMB as the first 3 letters. It is rumored that they are known locally by numbers, but officially as ordinary calls. Can some reader enlighten us?

From the South African Broadcasting Corporation, Ltd., at Johannesburg, comes the following letter:

"All South African transmitters are on the air from 6:45 A.M. to 7:30 A.M. South African time, or 11:45 P.M. to 12:30 A.M. Eastern Standard time, daily except Sundays." The list of stations that they sent shows Johannesburg to have the most powerful transmitter, using 15 kw. on 645 kc. This would be a wonderful catch for any DX-er.

The New Zealand DX Radio Association, Box 706, Dunedin, New Zealand, write that it is again summer in New Zealand. "Conditions in the summer in New Zealand, unlike summer in other countries, permit the early morning reception of foreign stations. We will include a valuable time chart in our next issue of our official organ, 'Tune-in' which will be a great aid in hearing stations in other countries, because all DX-ers should know when to tune, and what to tune for." Well said, Mr. Secretary Stanton! Incidentally, DX tips are broadcast in this country for the Association over KMBC, whose management tells us that they are conducting a series of experimental DX broadcasts every other Sunday morning, and at about 3:30 A.M. Eastern Standard Time an avalanche of DX tips is sent out for the association. Tips are also broadcast over KMBC at 12:50 A.M. Eastern Standard Time each Sunday morning for the New Zealand DX Radio Association.

And now we conclude our DX article with a list of the most often heard foreign stations in the broadcast band—Cheerio!

CONVERTING OLD SETS

(Continued from page 149)

place these shields too close to the coils or to the condenser or detuning may be the result. Also readjust the condenser gang after fastening the shields in place. If the set is a single-dial control. Second, in some of the older sets there is no plate bypass condenser, or if one is used it may not be large enough. Usually a .5-mf. condenser is large enough for this purpose. Sometimes a series resistor on the "B" side of this condenser will filter out any feedback. This resistor is about 20,000 ohms. Third, it is best to use 135 V. on the R.F. and the A.F. tubes, with about 45 V. on the detector. Proper "C" bias may not be provided for on the original set. If not, be sure that it is done on the rebuilt job. This not only gives better tone but a big reduction in "B" battery drain. Fourth, volume control in most of the older sets was accomplished by a rheostat in the filament of the R.F. tubes. This same type of control can be used in the new set, but usually the rheostat must be changed to about 25 ohms to give the proper control. The detector and the A.F. tubes must have 2 V. on their filaments to insure good tone quality. This is accomplished by having these tubes on a separate filament circuit.

In some sets the volume control was formerly a variable resistor in the R.F. plate supply. This type control may be retained; in most cases, however, the filament type of control is to be preferred. It has one peculiarity and that is the time lag due to the slow heating and cooling of the filaments.

In the older sets using triodes but having the coils shielded, approximately the same method of conversion is used as in the sets having no shielding. Sets of this type, being originally designed for high gain and stability, work fine as converted receivers. The circuit may oscillate due to exposed plate leads from the socket to the coil. These may be shielded with flexible shielding braid. Do not fit the shield too tight as it may cause detuning or loss by the capacity of the shield. In most cases the coil shields or cans are large enough to hold coils made for the screen-grid tubes and whenever possible they should be taken out and the new screen-grid type R.F. coils substituted. This means using 34s or 32s in the R.F. stages, with a resultant big improvement in the sensitivity of the set.

Now we come to the battery set designed to use the type 22 or 24 tubes in the R.F. section of a receiver. These sets are usually better designed than the older types and better results can be expected after they have been changed. The coils have been made for the screen-grid type tubes and usually the shielding in the original set is sufficient. The main job in this type of set is to provide the 34s or 32s used in the R.F. stages with the proper "C" bias. The correct minimum bias for both the 34 and the 32 is 3 V. There are several ways of doing this, as shown in the diagram. It is most important that this item be correct, especially where there are 3 stages of R.F. Sometimes it has been found necessary to place small R.F. chokes in the grid-return leads of the R.F. coils to isolate them from the remainder of the circuit. This choke is about 20 turns of No. 30 wire on a 1/4-in. dowel. Some experimenting may be necessary to gain the results desired. Sometimes just one of these coils inserted in the ground lead of one of the R.F. coils will stop oscillation that otherwise seems impossible to locate.

If the set has been originally designed to use the type 22 or the 24 tubes, a big saving can be made by substituting 34s in the R.F. stages and a 32 in the detector stage. These sets are designed excellently in the first place (generally speaking). That is, the shielding is usually efficient and the set has been designed to take full advantage of the screen-grid type tubes. If the set had 22 type tubes in the R.F. it is a simple matter to change to 34s. If it previously had 24s in the R.F. end it will of course be necessary to change to 4-prong sockets. The entire filament circuit will need to be rewired. It is possible to control volume in this type of set by a rheostat in the R.F. filament circuit. It is preferred, however, in a set of this type, to control the volume by controlling the voltage on the screen-grids of the R.F. tubes. A 50,000 ohm straight line variable resistor in series with a fixed resistor of about 50,000 ohms across the entire 135 V. of "B" battery will be found satisfactory. Bypass the arm or moving con-

tact of this volume control to the ground with about a .5-mf. condenser to prevent noise from the control. The "off-on" switch must disconnect both "A" and "B" from the set to prevent unnecessary drain on the "B" batteries while the set is not in use. The volume control itself uses only 2 ma. when the set is in use.

In the above conversions it has been assumed that 2 V. tubes are to be used throughout. In some cases it may be desirable to use larger power tubes such as the 71A so as to have extra volume to spare. This, of course, means an extra filament circuit and extra trouble, but sometimes this is necessary to gain the desired result. The 30 series tubes for all ordinary purposes will prove satisfactory.

Nothing has been said so far as to what kind of battery is to furnish the power to operate these rebuilt sets. There are 3 types of cells that can be used; dry cells, air cells, and the storage cells. Dry cells are used mainly on portable sets or where space is at a premium. They have the advantage of being small and they give off no corrosive vapor. They have one big disadvantage and that is the decrease in voltage after a short period of use. They must be used with an adjustable filament resistor to insure that the proper voltage will be on the filaments at all times. A filament voltmeter is really necessary to be sure that the rated voltage is never exceeded.

The air-cell battery can be used very easily and successfully if the main characteristics are understood. It would be well to read any of the numerous articles that have been written on the use of the air-cell before using it to power a battery set, as they go into the subject at greater length than is possible in this general discussion. The initial voltage of the air-cell is about 2.53 V. It is necessary to use a resistor to hold this down to the upper safe limit of the tubes which is 2.20 V. This resistor should be adjusted very carefully with the aid of an accurate voltmeter. If the voltage is above 2.20 on the tubes the life will be very short, therefore adjustment is to be made while using a fresh air-cell. As the voltage of the battery decreases with use it is necessary to have the original voltage on the tubes up to the upper limit of 2.20 so that the voltage will be high enough to operate the tubes throughout the life of the battery.

A single storage cell makes a good unit for lighting these tubes, since its voltages during each charge and discharge are well within the safe limits of the tubes. However, it is rather messy and has the disadvantage of having to be charged every once in a while. Nevertheless it has the advantage of being easy to use as it requires no compensating resistors to regulate the voltage. Fairly heavy leads should be used to carry the current up from the battery so as to prevent any appreciable voltage drop.

The diagrams shown have been used many times in rebuilding or converting sets. They may well be used as a basis for rebuilding any old receiver that you may come across. The diagrams may be followed as a whole, or any part may be used, depending on the type of set you are working on. The main idea is to use the correct voltages on the tubes to insure proper operation and long life. This must be done accurately, and with good instruments, to ensure success.

OPERATING NOTES

(Continued from page 158)

The cause of the trouble was thus located in the joint where the lead from the resistor was grounded to the chassis.

The peculiar action of the receiver can best be explained by reference to the figure. The flat, wire-wound resistor strips are rigidly held down at two points; when they get warmed up they will expand to an upward-curved position, pulling with it the lead connected from the resistor to the chassis. The end of the wire at the chassis was encased with solder, but inside of it the wire evidently was only loosely held in a wedge-shape manner, and the slight pull exerted by the upward motion of the resistors was sufficient to make this a temporary tight connection. When the resistors cooled off, the process would be reversed, and the wire pushed loose again.

R. F. LAMBERT.

Can you solve these AUTO-RADIO PROBLEMS?

- Locate and suppress quickly the interference of electrical discharges from the distributor?
- Locate and eliminate static generated while car is in motion with motor turned off?
- Is the positive or negative terminal of the storage battery grounded in the 1930 Plymouth model? The 1934 Pontiac?
- If a Majestic 66 auto-radio set breaks out with excessive noise, at which points do you try to locate the trouble?

See New Sylvania Service Book... for Quick Solutions Free to You... Clip Coupon

- New auto-radio book simplifies problems you are bound to meet in this fast-growing industry. Contains inside dope used by radio engineers in their every-day work on short-cut installations, accurate servicing of various types of sets, handy reference data, etc.

Get your free copy. It will help to make you a specialist in auto-radio . . . a business that Sylvania engineers actively advanced with their development of the 6.3 volt tube! HYGRADE SYLVANIA CORPORATION.

Makers of
SYLVANIA TUBES
HYGRADE LAMPS
ELECTRONIC PRODUCTS
© H. S. Corp., 1934

Factories
EMPORIUM, PA.
ST. MARY'S, PA.
SALEM, MASS.
CLIFTON, N. J.



Sylvania
THE SET-TESTED RADIO TUBE

HYGRADE SYLVANIA CORPORATION
Emporium, Pa. B-14

Please send free, without obligation, your new service book "Auto-Radio Installation and Servicing."

Name

Address

City State

RADIO'S LATEST DEVELOPMENT

Special Noise-Reducing Lead-In Cable

by the pioneer of noise-free aeri-als

- Improves Reception
- Simple to Attach
- Inexpensive

GIANT KILLER Cable

Makes any doublet aerial work better. Incorporates features which give lowest H. F. resistance; very low impedance; accurate impedance match with aerial without any transformers, tricky spacing, cumbersome metal tubing, or masts. **Simplest and best.**

See These Exceptional Results

350 feet of wire used to connect the antenna to both the receiver and the 160 watt, 1400 volt transmitter, at the New York Hamfest. Every part of the country and parts of Canada were worked on radio-phones. Hans has used 185 feet to feed a 5 meter rig successfully.

Special 110 ft. length to improve the new R. C. A. World-wide Antenna System, **\$6.50 List**

All-Wave Antenna System \$3.35
complete with 35 feet of the GIANT KILLER CABLE

Write for Free Descriptive Folder
ARTHUR H. LYNCH, Inc., 327 Fulton St., New York, N. Y.

IMPROVE YOUR RADIO

FOR efficient short-wave receivers and transmitters use the world-famous Hammarlund Condensers, Coils, Chokes, Sockets and Shields. Backed by 33 years of engineering leadership.

Write for new FREE CATALOG "RC-9"

HAMMARLUND MFG. CO.
424 W. 33rd Street
New York City

For Better Radio
Hammarlund
PRECISION PRODUCTS

USE SHURE MICROPHONES
and Related Equipment
Highest Quality . . . Low Cost

Ask your Jobber about our Latest Models

ARE YOU GETTING THE SHURE TECHNICAL BULLETIN?

Send 6c for Sample Copy and List of Back Issues, or 50c for One-Year Subscription.

SHURE BROTHERS COMPANY
Microphone Headquarters
215 W. Huron Street Chicago, Ill.

SOLAR ★

WET AND DRY ELECTROLYTIC PAPER AND MICA CONDENSERS

RECOGNIZED FOR SUPERIOR QUALITY IN ALL CLIMATES THE WORLD OVER

SOLD BY LEADING JOBBERS EVERYWHERE

SOLAR MFG. CORP.
399 BROADWAY
NEW YORK

BEST BY TEST!

ASK FOR CATALOG OF EXTREMELY COMPACT TYPES HANDY FOR SERVICE

BETTER SERVICE Always

ALLIED RADIO

REPAIR DYNAMIC CONES

(Continued from page 148)

(5) Trouble is encountered many times from voice coils that do not hold their shape and are too flexible. Chattering may sometimes be attributed to spiders that are not stiff enough, or broken, or by cones that come loose on the outer edge where the ring is supposed to rigidly clamp it.

The above five points of trouble will cover practically all the elements that may go wrong with a speaker (except damage to the frame of the speaker or the cone itself).

The Use of "Shims"

Now if after checking the speaker the Service Man finds that his trouble is in the voice coil being off-center, the simplest thing to do is loosen the supporting screws of the spider and very carefully insert around the pole piece small steel shims (particularly adapted for this purpose) of the proper size, tighten the spider supporting screws again and then remove the shims. The cone should be perfectly centered, providing the spider has not warped, the cone is not out of shape, and the voice coil is true and round. About 75% of speaker troubles may be repaired by this simple adjustment.

If adjustment in this way cannot be properly made then you have a bigger job on your hands. It will probably be necessary to remove the cone and check in detail. To remove this cone you must be careful not to damage it, because it will have to be replaced again. In many of the newer type of speakers you will find the cone cemented on the rim, and to remove this the rim of the cone should be saturated with a specially made solvent until the old cement dissolves, and then the cone may be lifted off (it usually takes from 5 to 10 minutes for the solvent to sufficiently loosen the old cement). Do not use water as it will ruin the cone and it will not loosen the cement, since the cement used on speakers is waterproof.

Examination of Cone

After the cone is removed it must be closely examined. All loose parts should be re-cemented and if the voice coil seems to be out of round, true it up by inserting a round tapered cork of the proper size on the inside of the coil, and then coat the coil with a very thin solution of the cement. The cement will tend to stiffen the voice coil and keep it in shape. A finger is the best "tool" for applying this cement on the voice coil as it is necessary to not have any lumps or uneven spots on the coil. If too much cement is applied it can be smoothed out or washed off with solvent without any damage to the coil or the paper as the solvent evaporates readily.

It is a good practice to re-cement all the former cemented parts on the spider and seams of the cone, even though they seem to be in good condition, as sometimes the break in the cement that causes the rattling is not visible. If the spider is found to be too flexible it may be stiffened by coating it with cement.

After the cone is repaired it should be set aside to dry for at least an hour and then replaced. The cement will dry in 15 minutes but an hour gives it plenty of time to set properly. In replacing the cone the shims should again be inserted to properly align the cone, and the spider set-screws then tightened. The edge of the cone should then be re-cemented and the shims removed after the job is dry and completed.

In some cases if it is found that the voice coil is open or shorted and repairs cannot be made in a practical manner it is wise to replace the cone with a new one rather than attempt repairs.

A Profitable Field

Repairing reproducers is one of the most important jobs that the Service Man encounters. It is not a difficult job but requires more patience and practical reasoning than most other repairs on a radio receiver.

With care, a little mechanical ability, and the new service aids for this work, the job can be made an easy one. With a little practice the Service Man should soon become an expert in overcoming cone speaker rattles, distortion, or mechanical cone defects.

HOW SHIELDED LEAD-INS MISBEHAVE

(Continued from page 153)

of the intruding oscillations. The grounded shield is such a closely parallel oscillating circuit. Its short-circuiting effect, as well as its own interfering oscillations, can be suppressed by connecting a high resistance in series with the shield and its ground connection. This is common practice. Unfortunately, this resistance also hinders the bypassing of the inductive interference. Some sort of compromise is usually attempted, whereby interference will be lessened without too great loss of signal strength.

Experimental Verification

The experiments outlined below were conducted in an unscientific manner, no output meter being available. Percentages of decrease are only estimates, judged by ear alone, but the effects observed were verified by repeated tests extending over a period of several weeks.

Since the type of receiver may have some bearing on results, it is well to state that the one used is a 1933 model, single-dial, long- and short-wave superheterodyne; nominally 10-tube, but really a 6-tube circuit, since 2 of the 10 are power supply tubes and two others are cut in only when switched to short-wave operation. It has no automatic volume control. Owing to the fact that its short-wave reception is poor, and tests were generally limited to afternoons, little information was gained in the short-wave region.

In noting effects, both shields were first unconnected and ungrounded, and a station tuned in to normal volume. Various changes were then made in shield connections, and effects judged by ear. Losses of signal strength are thus based on normal setting of volume control, and not on absolute sensitivity.

Description of Fig. 1

In Fig. 1, shields only are shown, omitting the enclosed wires, which do not concern these experiments. Short bends indicate the ends next to the receiver. Shielding continues up to 1 in. from the chassis, the ends being insulated to prevent accidental grounding or shorting at that point. Since the effectiveness of shielded leads as interference eliminators depends on factors mentioned at the beginning of this article, the following notes deal only with the incidental effects on sensitivity and selectivity:

Types of Lead-in

(A) Lead-in shield, only, grounded at the lower end to a separate ground (water pipe, 15 ft. from meter). Local: cuts the desired reception 80 to 90%. The volume control must be turned much higher to restore the signals. Distance: no appreciable effect on reception. (Note: the volume control naturally was set for higher sensitivity when tuning for a distant station.)

(B) Same as A, except that the ground-wire shield is grounded at the lower end, to a regular receiver ground. Local: cuts out all signals at the normal setting of the volume control. Distance: a slight reduction in strength.

(C) Shields ungrounded, hut connected together near the receiver. Local: signals reduced 50%. Distance: all signals out. (Similar effects were noted on the short waves.)

(D) Same as C, with the addition of a ground connection at the lower end of the ground-wire shield. Both local and distance reception were silenced at the normal settings of the volume control.

(E) Shields connected together at the receiver, and the connection grounded to a separate ground (water pipe, 15 ft. from the receiver ground). Local: cuts signal strength about 75%. Distance: a slight increase in volume. Here is the automatic volume control effect mentioned. Although the leveling is much less than with standard A.V.C., it is quite noticeable. Evidently the excess power of local stations, which causes blasting, spreads through the local area close to the ground.

(F) Shields connected, near the receiver, with a 10,000 ohm potentiometer, R. Variable contact connected to a separate ground. Local: when the contact is within 2,000 ohms of the lead-in end, signals decrease more and more until conditions approximate those of test A. Distance: signals begin to weaken within 3,000 ohms of the lead-in end. At 1,500 ohms the

signals are practically extinct, coming in again as the contact is moved farther toward the lead-in end. With no resistance between the lead-in shield and ground, no appreciable effect is noted. (See A.)

(G) Ground shield grounded at lower end. Local: less than 500 ohms in R cuts down the volume. Zero ohms, silence. Distance: less than 500 ohms, cuts volume. Zero resistance, practically extinguishes signals.

(H) Shield circuit completed through a variable inductance, L, grounded as shown. Local: when tuned to a longer wavelength than the signal being received, it has no appreciable effect. Tuned to resonance with the signal, it nearly doubles the volume. Tuned to a higher frequency (shorter wave), it diminishes the volume; further reduction of the inductance value cuts the reception almost to zero. Distance: same as for local, except slightly less pronounced variations.

Recommend Antenna Connections

In the light of these experiments, recommended connections are as shown in Fig. 2, where dotted lines represent the antenna lead-in and ground wires, while the shields are indicated by solid lines. The lead-in shield is connected through an R.F. choke, R.F.C., directly to the ground shield or "Gnd." binding post of the receiver. A relatively low impedance bypass is thus provided for A.F. interference, with extremely high impedance to radio frequencies. This means, the best possible shielding, with imperceptible loss of sensitivity. Unit R.F.C. may be any standard choke designed for broadcast frequencies down to 550 kilocycles. If shielded, so much the better.

Figure 3 (A and B) shows the hookups for using the shield circuit as a volume control, wavetrap, or signal booster. Note that the shields (solid lines) are entirely insulated from the lead-in and ground wires, except at the common ground connection. Coil L is a regular grid-circuit coil for broadcast frequencies. The variable condenser may be of 350 mmf. or 500 mmf. capacity.

Unless the main purpose is to experiment, it is well to find out beforehand whether the interference is of a kind that can be lessened by shielded leads or a "noise-free" antenna system. The test is as follows:

Testing the Lead-In

Some time when the interference is bad, and not due to real (atmospheric) static, tune in a distant station—not the most distant, but one that ordinarily comes in with good volume. While listening, disconnect the aerial and ground wires from the set and connect the two leads together, permitting them to remain loose from the set. The only sounds now coming from the receiver should be a low hum and possibly a faint rushing noise which is the normal tube hiss at the high-sensitivity setting of the volume control. Any obtrusive noise, with the aerial circuit thus disconnected and the receiver tuned to an outside station, is due to:

(1) Conduction through power cord. Use a line filter, plugged into the outlet from which power is drawn. Plug the radio power plug into the filter receptacle, and connect the filter "Gnd." binding post (provided) to a ground. Or, follow the directions accompanying the filter.

(2) Defective resistors, leaky condensers, leaky insulation, poor socket contacts, poorly soldered joints, defective tubes, excessive voltages—all these will cause the receiver to generate internal noises. Have the receiver overhauled by a competent Service Man if you do not care to do the work yourself.

(3) Many receivers are poorly shielded, or even wide open, underneath. If the lead-in—or any other grounded wire—extends below the chassis, there may be direct radiation to the wiring of the receiver. If the latter is very sensitive, and especially if it is a superheterodyne, several different stations may be picked up at the same time, with sufficient strength to cause interfering beats, whistles, chirps, fluttering, or disagreeable background noises. Do not let the lead-in hang down lower than the bottom of the chassis. See that no wire—not even the ground wire—runs under the radio. If the chassis lacks a metal bottom, an extra shield can be fitted up under the wooden shelf upon which the chassis rests. This shield may be of ordinary tinned iron (commonly called "tin"), although copper or aluminum would be better. It should have a wire soldered to it for connection to the ground post of the receiver. It must be installed in such

a way as not to interfere with removal of the chassis for inspection or repairs. If the chassis is held down by bolts through the wooden shelf, cut slots in the ends of the metal sheet, slightly loosen the bolts and slip the ends of the metal sheet under the bolt heads or washers, and re-tighten.

BEWARE— THE SERVICE GYP

(Continued from page 145)

called. Typical reports as to what was wrong with the radio receiver and the estimated cost for repairing as given by some of the 'free estimate' Service Men were as follows:

- (1) Light overhauling needed. Cost, \$2.90.
- (2) Condenser and voltage divider. Cost, \$4.50.
- (3) New cone and field coil needed, \$5.75.
- (4) New Speaker field coil. Cost, \$4.50.
- (5) New condenser, \$1.75. Output transformer, 85c, plus labor. Total charges, \$4.60.
- (6) Audio transformer needed. Cost, \$3.50.
- (7) Voice coil necessary. Cost, \$3.00.
- (8) Filter condenser repair. Cost, \$3.75.
- (9) New filter condenser. Cost, \$7.25.
- (10) Speaker coil necessary. Cost, \$2.75.
- (11) Speaker cone and voice coil, \$7.00.
- (12) Field coil needed. Cost, \$5.00.

"Out of approximately 25 'free estimate' calls a small percentage of the Service Men found the actual trouble and offered to repair the set for \$1.50!

Service Charge Operators Called

"Using the same 'prepared' set the Bureau then called a number of radio service concerns or individuals charging from 75c to \$1.50 for service calls regardless of whether or not they make the repairs necessary. The same wire was disconnected.

"Approximately 90 percent of the 'pay service' concerns found the loose wire at once and either repaired the set at no extra cost above the service charge or made an additional charge. No estimate was more than \$1.50.

One Fraudulent Operator Caught

"Only one of this group attempted to run up charges on the set. This operator, who charged 75 cents for the service call, stated the radio had a burned-out condenser which would have to be replaced and that it also needed one H.P. resistor, one 250,000 ohm resistor, all loose connections soldered and the speaker cone tightened. His repair charges were set at \$6.25.

"Following his estimate the set was checked by the committee and it was found that additional wires had been cut. These were left as found but all parts were marked by a Bureau investigator in the presence of the committee. The Service Man was then called to pick up the set and repair it.

"Upon its return the radio was examined. The wires had been repaired but none of the parts charged for had been replaced!

Called to Prosecutor's Office

"The repair man was called before Michael W. O'Hern, assistant prosecuting attorney, and was confronted with the marked radio set and the receipted bill showing the parts charged for.

"He admitted his guilt and asked for leniency. No announcement yet has been made by Mr. O'Hern as to whether or not action will be taken against this operator.

"This radio service investigation is being continued by the Better Business Bureau. Other sets have been placed in residences to check the claims of repair men suspected of defrauding the public. Only by constantly combating such evils can the public and legitimate radio service concerns be protected."

(Editor's note: In New York City the service racket is far worse than that depicted for Kansas City. The editor in going through the files of the N. Y. C. Better Business Bureau found an astonishing number of complaints against "gyp" radio service organizations, many of which, through the meritorious efforts of the B. B. B. culminated in a satisfactory adjustment.)

NO. 1181

TRIPLETT engineers developed the ALL-WAVE Oscillator, in answer to the growing demand from service men for a well designed, completely shielded all-wave signal generator. This new Triplet instrument is advanced in design, precision built, compactly constructed, and absolutely dependable. It gives a signal output of constant level . . . either modulated or unmodulated.

The charts are hand calibrated and cover a frequency range of 110 to 18,000 KC. The frequency ranges are controlled by a 4-position band change switch. All bands covered as fundamentals. The condenser shaft is at ground potential. This means there is no radiation of signal from condenser shaft or screws. A perfected attenuator control makes it possible to use the signal generator on the most sensitive as well as the weakest receivers.

No. 1151 is a single All-Wave Oscillator. Dealer's net price. . . . \$23.34

No. 1180 is made up of the combined All-Wave Oscillator and Volt-Ohm-Milliammeter. Dealer's net price. . . . 30.00

No. 1181 is a combination of Volt-Ohm-Milliammeter, Free-Point Tester, and All-Wave Oscillator. Dealer's net price. . . . 38.00

Your Jobber Can Supply You

The Triplet Electrical Instrument Co.
77 Main St. Bluffton, Ohio

Mail today for details!



The Triplet Electrical Instrument Co.
77 Main St.,
Bluffton, Ohio.

Gentlemen:

Send me catalog on Triplet ALL-WAVE Oscillator, and your complete line of radio servicing instruments.

Name

Street Address

City State

Dependable Sensational Performance!

BUD

Laboratory-Built
P. A. Equipment

5 DAYS FREE Trial

Try **BUD Sound Equipment** For Five Days Absolutely Free!

PORTABLE SOUND SYSTEMS
ELECTRO-DYNAMIC UNITS
CARBON AND CONDENSER
MICROPHONES - 4 & 8 FT.
ALL ALUMINUM TRUMPETS
FIELD EXCITERS-AIR COLUMN
HORNS - LOW AND HIGH
FREQUENCY UNITS FOR WIDE
RANGE THEATRE USE

We invite careful, critical inspection of our entire line of BUD laboratory-built sound equipment. We suggest that you conduct your own comparative test. We CHALLENGE you to duplicate BUD performance and BUD DEPENDABILITY AT ANY PRICE! Write today for descriptive literature and prices and details of our FREE FIVE DAY TRIAL offer.

BUD SPEAKER CO.
1115 JACKSON ST.
TOLEDO, OHIO, U.S.A.

PAYS FOR ITSELF

A CHUCKKER more than pays for itself on the very first job! The REPAIR-FIXER feature of this compiled cross-indexed radio trouble-chart, is based on a \$1.50 hourly labor charge plus list-priced replacement parts. You may believe you do not need a Chuckker to isolate quickly the specific faults causing specific radio complaints; but, you MUST have a Chuckker to know accurately WHAT TO CHARGE. Do this: On your next service call show the set owner the really profitable price (Chuckker publishes for the necessary repair. You will be surprised at the ease with which you get that job, and gratified with the professional fee you secure. A Chuckker inspires confidence! Eliminate guess-work in WHAT IS WRONG and WHAT TO CHARGE.

SEND
\$1.00
NOW
for yours, postpaid

FREED'S RADIO CO. (Dept. R)
5053 Baltimore Avenue Philadelphia, Pa.

WORLD WIDE ALL WAVE RECEIVER

Get foreign stations, police, amateurs, airplanes, local broadcast stations, etc. DIRECT with the remarkable feature. A REAL all wave radio set! Results Guaranteed! Complete kits contain all necessary parts to construct receiver. Clear picture diagram.

Two Tube Dry Cell or AC Models \$4.75
Three Tube AC-DC
House Current Kit \$6.75

ORDER NOW! or send for free literature. Deposit required with all orders.

HARRISON RADIO CO. Dept. R-9 142 Liberty St. New York City

CONCOURSE

Dry Electrolytic
Wax Paper
"Peewee" Paper Tubular
CONDENSERS

389-409 WALES AVENUE, NEW YORK
Write for 1934 Catalog

A-C CURRENT ANYWHERE!

WITH **KATO LIGHT PLANTS**

Operates AC radios, amplifiers, refrigerators, and all other standard household appliances. 8 1/2 to 300 watts and up. Write for interesting descriptive literature.

KATO ENGINEERING CO.
Mankato, Minn., U. S. A.
Mfrs. of AC Generators and Converters for operating AC Radios on 32 and 110 volts DC

NEW SERVICEMEN!
Something NEW in P. A. SYSTEMS:

DEALERS! Servicemen! Make big money renting or selling the new Postal All Purpose P. A. System. Simple to install. Extremely low in cost. Write for free descriptive circular.

POSTAL RADIO CORP., 135K Liberty Street New York, N. Y.

"Rocket" Tube Practice

The radio Service Man has furthermore been encouraged to follow these practices by the urging of the largest reputable manufacturers. When large tube manufacturers advise the radio Service Man to offer to inspect the customer's radio set without any charge with the idea in mind of selling the customer a new set of tubes, what is he doing?

First, he doesn't care whether the Service Man makes much money but is only interested in selling tubes. Second, the Service Man says to himself, "if these tube manufacturers have decided that this is the legitimate way for me to conduct my business, it must be, for who am I to question the intelligence and plans of million dollar organizations?" Third, the Service Man is led to believe that his services are not worth anything and that his sole income is to be derived from the sale of tubes or other parts whether the customer needs them or not.

Drawing the Line

(Editor's note: There should be a line of distinction here. While the margin of profit on tube sales is indeed small, still we believe it is fair return to the Service Man to reimburse him for his labor in testing the tubes, overhead, etc., providing the tubes are brought in for testing. Where a service call is made and tubes are shown to be at fault, a reasonable charge should be made for the trip in addition to the list price charge of each tube that is changed. Unfortunately, we must admit, very few Service Men are content with the small profit that is made on such a sale, and therefore there arises a tendency to invoke racketeering methods for making a service call pay.)

We doubt if the manufacturer can be blamed, except perhaps in regard to his recklessness in selling to "cut price" dealers. Because of "cut prices" in tubes "gyp" service methods have been encouraged, since Service Men cannot possibly make a service call pay on the narrow margin of profit obtainable on the sale of a few tubes.)

Fundamental Corrective Measures

After reading the above, you might say just as Mark Twain once said, "Everyone complains about the weather but no one does anything about it." Mark Twain's statement is very true for obvious reasons, but surely something can be done about the radio service situation.

Radio manufacturers continually emphasize the importance of the Service Man and in connection with automobile radio equipment, they even go so far as to investigate and appoint official service stations so that their products will be properly installed and serviced. However, do they try and see to it that the Service Man gets a legitimate charge for honest and efficient service? They are not concerned with his welfare, for if the Service Man is foolish enough to conduct his business on an unsound basis let him suffer.

Here is the point where something can and should be done. Let manufacturers cease advertising automobile radio receivers with free installation, as this sort of pricing does not allow the dealer to pay a legitimate charge to the Service Man for installation and service. The manufacturer should look further than the end of his nose and realize that, inasmuch as the Service Man is getting very little for his services, he is going to be compelled to use dishonest methods to get money from the public so as to survive. All this in the end tends to lower the confidence of the public in radio in general and has its adverse effect upon the manufacturer.

(Editor's note: The cut-throat service organizations employ a great number of tricks that will not pass the spotlight of square business methods. We are very much interested to hear of some of these shady practices as used by such radio houses, and we urge "legitimate" radio men to write to us and let us know of any unfair competition that makes it difficult to run an honest business.)

BACK ISSUES of RADIO-CRAFT prior to December, 1932, are available at 50c per copy. Succeeding issues are still available at the regular price of 25c per copy.

SHORT CUTS

(Continued from page 159)

A CONVENIENT TUBE SHIELD (Fig. 6)

W. T. Claytor

WHERE space is at a premium vacuum tubes may be shielded as shown in the figure. If it is difficult to obtain aluminum paint which with a continuity meter will show conductivity, tinfoil may be substituted, although most "5 and 10" stores carry suitable paint.

A HANDY SPEAKER PLUG (Fig. 7)

A. Rounsa

A HANDY plug that may be used for speaker connections, for instance, may be made by sawing off the prong-end of a tube base and attaching a short handle, as shown in the figure.

LATEST IN RADIO

(Continued from page 139)

ing directly up.

Voltage variation is very small between no-load and full-load. Motors up to 1/4-h.p. may be used on the 300 and 500 W. A.C. plants provided they are of the repulsion-induction type. The plant is ideal for power supply in summer homes and on small farms. An all-electric radio set may be operated at an approximate cost of 1c per hour. Newly developed refrigerators which draw very little current can also be operated.

A new and recent generator design gives the plant exceptionally fine voltage regulation. The 110 V. A.C. winding is entirely independent of the field exciting winding. Direct current for the field is supplied from a 40 V. D.C. armature winding. This winding serves a triple purpose. Besides supplying D.C. field current, it cranks the engine electrically when supplied with D.C. from a storage battery, and also keeps the starting batteries charged at a low rate.

Normal voltage drop change in the generator winding due to increasing and decreasing loads, does not affect the field current because the field current is supplied by a separate winding.

When the plant is used with starting batteries, these serve to stabilize the output voltage to a further degree by absorbing the increased D.C. voltage when the plant is running with partial-load. These batteries keep the voltage on the generator field at approximately the same voltage between partial-load or full-load.

These A.C. plants may be made self-starting by connecting to 2 small, 6 V. auto-type storage batteries connected in series. A field-exciting armature winding automatically keeps these batteries charged. The plants may be started and stopped from remote points by installing bell push buttons in convenient places.

Lights are bright with no flickering; this is mainly due to the improved design of the coupling.

The plant has the following specifications: 300 W., 60 cycles A.C., electric starting; engine, 1/2-h.p. at 1,800 r.p.m. Emergency hand-starting lever. Fuel tank, 2 1/2 pints capacity, mounted on back of engine; oil supply, 1 pt. One gallon of fuel will carry full-load for approximately 8 hours. Generator has 2 separate, ball-bearing windings. Dimensions, 27x15x17 ins. high. Net weight, 127 lbs., crated 150 lbs. Finish, black, heat-resisting enamel.

An electric plant. (No. 537)

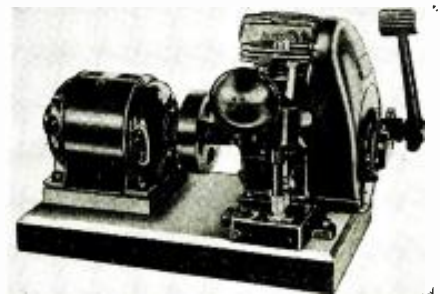

TALK AND HEAR OVER A LIGHT BEAM

(Continued from page 141)

the projector head in a vertical arc. Make up the trunions from pipe fittings as specified and shown; no elaborate bearings are needed for allowing the head to swing either vertically or horizontally as the movement is small and seldom required—once focused on a receiving station it will probably be left that way for long periods of time. Make up a 3 sided cover to fit snugly over the entire unit out of presd-wood and then paint everything, inside and out, with a coat of "flat black" paint. Note that this paint must not be conductive in the slightest degree.

The Receiver

Make up a disc of heavy wood to fit snugly inside one end of the stove pipe, on the center of this mount a 4 prong tube socket with angles in such a position that the concave side of the plate in the photo cell faces away from the board and is centered on it; mount a condensing lens on another piece of wood fitting snugly inside the pipe (with a hole through it for the light to pass, of course). Focus an image of the sun onto the position occupied by the plate of the photo tube (but NOT onto the plate) through the lens so that the image covers the entire width of the plate and fasten the lens to the board with a couple of strips of metal in this position. Mount 2 binding posts on the socket board for leads to the cell. Place this assembly inside one end of the stove pipe, find the balance point and mount 2 blocks with holes to fit 3/4-in. pipe at this point. Then paint the entire unit, inside and out, with "flat black." Make up another trunion similar to the one for the transmitter.

The Amplifier

The amplifier is more or less standard equipment, except that it is designed to operate from a 6 V. battery and incorporates its own power plant in the form of a compact motor-generator unit, and has a rather higher gain than the usual A.F. amplifier to allow of driving a loud-speaker from the extremely minute output of a photo cell. All voltages, including bias voltage for the photo cell and power required for the projector lamp and modulator field coil, are taken from the binding post strip on the amplifier chassis which reduces the hookup to very simple terms, and everything is controlled from the single switch on the chassis.

The bias voltage for the photo cell is taken from the 90 V. tap of the motor-generator through resistor R2, which acts as a filter resistor to remove all trace of commutator ripple since it is by-passed by the 2 condensers, C12, C13; and through the load resistor, R1. The variations of voltage due to the action of modulated light on the photo cell are transferred to the grid of the type 77 tube through coupling condenser C1, R20 acting as a volume control for the input signal, which is then amplified through the remaining stages and fed to the receiving speaker through condenser C19. The signal to this speaker is controlled through switch S1 in the ground lead. This switch is made necessary by the fact that the same amplifier is used for both receiving and transmitting and hence feedback to the microphone would occur if both speaker and microphone were on together. Of course this means that "break in" communication is not possible, one party having to wait until the other is through before answering. To allow strictly 2 way communication the headphone jack is provided and this will allow the speaker to use both headphones and "mike" at the same time and permit "break in" operation.

The signal from the mike is fed into the grid circuit of the type 79 tube through switch S2. No volume control or matching transformer is provided as these are incorporated in the microphone unit specified, as well as the microphone battery.

The mechanical layout of the chassis is clearly shown in the photographs and the construction should present no difficulties to one at all familiar with radio construction. Some may think that there are an excessive number of resistors and bypass condensers used, but rest assured that they are all necessary to insure stable operation of a circuit having as high a

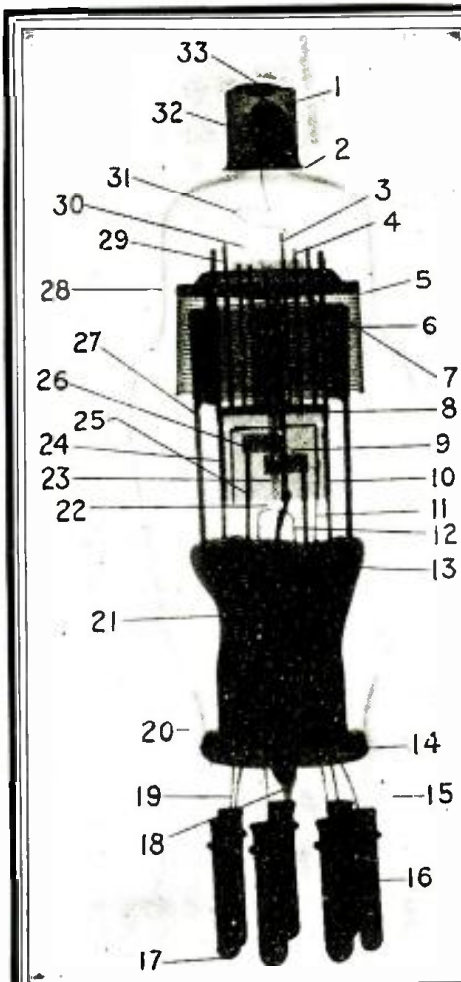

NATIONAL UNION TUBES X-RAYED

The National Union laboratories have x-rayed some of the newer type tubes to illustrate their complexity and the necessity for extreme accuracy during course of manufacture. Engineers and technical experts with years of experience supervise every step in the manufacture of National Union tubes to insure their consistent superiority. The part of the type 2B7 shown x-rayed at the left are: 1. Top cap; 2. Top Cup Cement; 3. Control Grid Supports; 4. Screen Grid Supports; 5. Shield; 6. Plates; 7. Mica; 8. Collar; 9. Screen Grid Connector; 10. Diode Shield Welds; 11. Screen Grid Weld; 12. Heater Welds; 13. Stem Press; 14. Bulb to Stem Seal; 15. Base; 16. Base Pins; 17. Solder; 18. Exhaust Tube Tip; 19. Lead Wires; 20. Insulating Cement; 21. Exhaust Hole; 22. Heater Coil Legs; 23. Cathode; 24. Diode Shield; 25. Diode Plate Welds; 26. Diode Plates; 27. Plate Supports; 28. Bulb; 29. Suppressor Grid Supports; 30. Cathode Tab; 31. Curl; 32. Tubulated Tip; 33. Solder.

FREE SHOP EQUIPMENT

Service dealers who want to keep up to the minute need modern equipment and data. National Union knows the problems of the service business and supplies FREE with National Union tube purchases: Service Manuals, Supreme #333 Analyzer, Service Tool Kit, Supreme #85 Tube Tester, Hickok Tube Tester, #1180 Perpetual Tester with All-Wave Oscillator, Triplett Tube Tester. Small deposit.

Other features of National Union's program for Service Profits include: 1. Ten Cent Higher List Price. 2. Service Aids, Charts, Data. 3. Sales Aids. 4. Superior quality. 5. Tubes Sold at Full List Price. Thousands have tied up with the National Union plan for profit... why don't you.

NATIONAL UNION JOBBER STOCKS ARE COMPLETE.

National Union Radio Corp. of N. Y.
400 Madison Avenue,
New York City.



Tell me more about.....
Name.....
Street.....
City..... State.....

"Multi-Tap"

POWER TRANSFORMERS!

(Patent Applied for)

The wide range of adaptability of only five models "Multi-Tap" Universal Power Transformers is made possible thru various taps in these units which may be used singly or in combinations. The required current values can be delivered to each of the several leads in the set with any combination of tubes, as accurately as by the original power units. Easily installed.

SERVICE ENGINEERS

This is a real opportunity for you!

NECESSITIES

to protect the enormous investments in radio sets now in use by your customers. STOCK OF ONLY FIVE (5) POWER TRANSFORMERS provides immediate renewal of original performance in case of trouble in the transformer—the heart of the radio—in any of more than 90% of all radios, whether "orphaned" or current models.

Every radio dealer needs a kit of "MULTI-TAPS" to insure continued radio service to his patrons.

AC 110-120 V., 50-60 Cy., 220-240 V., 50-60 Cy., 115 V., 25-40 Cy., 150 V., 50-60 Cy.

FREE FOR THE ASKING —

"MULTI-TAP" Bulletin No. 6, listing 1927 models of radios which you can immediately service with one of only 5 "MULTI-TAP" power and input, output, and filament transformers.

GENERAL TRANSFORMER CORPORATION

504 S. Throop Street

Chicago, Illinois



Back Issues of Radio-Craft

which you might need to complete your files, can still be had at the price of 25c per copy. Send us your requirements, together with your remittance in check or money order.

RADIO-CRAFT, 99 Hudson St., N. Y. C.

BUILD YOUR OWN

See Page 183

ALLIED RADIO

THE SET YOU HAVE ALWAYS WANTED



the "MJ" for the truly critical
There is no finer all-wave receiver
Write for Details
PIONEER SOUND LABORATORY
135 Liberty St. New York, N. Y.

When Seeking a Radio School . . .

Consider the advantages of RCA
Institutes

Whether elementary radio principles or advanced subjects, sound applications or practical radio engineering, RCA Institutes is prepared to give you the instruction you need.

Students attending our Chicago School this Summer have added advantage of combining a study of the scientific wonders of the World's Fair.

RESIDENT SCHOOLS NEW YORK & CHICAGO

with modern standard equipment

EXTENSION COURSES FOR HOME STUDY
under convenient "no obligation" plan

Illustrated Catalog on Request.

R. C. A. INSTITUTES, Inc. Dept. RT-34
75 Varick St., New York—1154 Merchandise Mart, Chicago

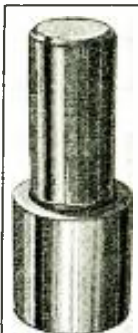

NEW! SHEET METAL PUNCH FOR

**Servicemen
Experimenters!
Amateurs**

Knock out those socket and electrolytic condenser holes in METAL chassis easily and quickly in 5 seconds. All you need is a KAY PUNCH and a hammer. Hole sizes: $\frac{3}{8}$ ", $\frac{1}{2}$ ", 1-3/16", 1 1/8".

\$1.50 Your price each net. F.O.B.
Shp. Wt. 2 1/2 lbs. Remit by check or money order for full amount.

KAY SPECIALTY MFG., COMPANY
119 S. BROOM STREET MADISON, WISCONSIN

**HIGHEST
QUALITY** Standard Lines
ALLIED RADIO

**FREE! NEW RADIO
CATALOG**

Packed with new model radio VALUES at rockbottom wholesale prices. Money-back guarantee and 30-DAY FREE TRIAL IN YOUR HOME on every set! All types. Send for big, new FREE catalog \$9.45 up TODAY. Price

FORDSON RADIO, Inc.

Dept. 9-39, Oakman Bldg. DETROIT, MICH.

BE SURE TO READ THE ANNOUNCEMENT ABOUT THE NEW 1935 OFFICIAL RADIO SERVICE MANUAL WHICH APPEARS ON PAGE 163 OF THIS ISSUE.

gain as this one, uncontrollable audio oscillation will be the likely result of skimping in this quarter.

Operation

After all units are constructed and assembled the outfit should be tried out in the laboratory. Unless you are building 2 complete stations of transmitter and receiver it will be necessary to use a temporary amplifier for either receiving or modulating. Any standard A.F. amplifier will do the trick if it is properly matched into the input or output circuits, as the case may be.

Set up the projector head and couple it to the amplifier, then set up the receiver also coupled to an amplifier and proper bias potential on the other side of the "lab." Cut down the brilliancy of the projector lamp (with a series resistance) and focus it on the receiver cell. Adjust the light gate to a very narrow slit—talking into the mike should now produce an audible signal at the receiver with the projector lamp at very low brilliancy. If this test proves satisfactory you may now proceed with an outdoor test for distance, getting further and further apart while increasing the brilliancy of the projector lamp proportionately. This test will probably be easier if made for the first time at night, though daytime communication over considerable distances is possible if the photo cell is well shielded from all sources of light except that emanating from the transmitter.

After the distance test is successful you may mount the projector and receiver in any convenient location where they will cover the territory desired and you may go to any lengths your ambition will permit in the complication of this mounting—if you desire that they be aimed from within the station it can be done, providing you are skillful and ambitious enough to build the necessary apparatus. One point must be noted, however, if you can mount the projector and receiver inside the attic and point them through a window it will save a whole heap of trouble in making the apparatus thoroughly weather-proof, which must be done if they are to be mounted outside. That, however, is, I suppose, a lazy man's viewpoint and may not meet with your approval.

In General

The subject of photo cells in general was covered rather thoroughly in the August issue of RADIO-CRAFT (The P.E. Cell, page 86) and the builder of this apparatus is advised to read this article carefully if he has not already done so.

However, no data is given as to specific cells, therefore this information covering the cell specified herein is supplied.

Characteristics of type 868 phototube.

Anode supply voltage.90 max. volts.
Anode current.20 max. microamperes
Static sensitivity.55 microamps. per lumen
Dynamic sensitivity
(1000 cy.)50 microamps. per lumen
Dynamic sensitivity
(5000 cy.)48 microamps. per lumen
Load circuit resistance 0.1 to 5.0 megohms
BulbT-8
BaseSmall 4 pin

While in operation the cathode of this tube should never be exposed to an excessive amount of light or the sensitivity of the tube will be appreciably reduced. If subjected to direct sunlight the tube will probably be permanently damaged. If subjected to direct sunlight while not in operation the sensitivity will be temporarily reduced by an amount, and for a period of time, dependent on the length of such exposure.

The 868 is also sensitive to temperature and will be permanently damaged if operated above 120 degrees F. This means, in the present practical instance, that if the receiver head is to be mounted where it will be exposed to direct summer sunlight it had better be painted with silver paint to reflect rather than absorb the heat of the sun.

The amount of light and anode voltage should be adjusted so that the current through the tube will never exceed 20 microamperes. Excessive light or voltage will cause the gas in the tube to become conductive, which fact is made known by a blue glow within the tube. If this glow is allowed to persist for more than a few seconds, or occurs frequently, the tube loses sensitivity and the ability to respond uniformly to modulated light.

Remember, also, that the phototube is a high-resistance device. This means that all circuits associated with the tube must have extremely good insulation resistance, and that the tube base and socket must be kept clean and free from accumulations of dust and moisture.

Aside from the points brought out above relative to the phototube, with which the average radio man is not yet thoroughly familiar, the operation of the device is subject to the same rules and conditions relating to any radio device.

The motor-generator specified is extremely rugged and requires no attention whatever as the special ball bearings are packed in grease and the brushes are of special alloy composition which will wear indefinitely. Unlike vibrator devices, sometimes used for the same purpose, the motor-generator is not harmed by operation with n-load and will stand a 30% overload indefinitely. The generator is filtered within its own housing sufficiently for use with the average radio set (for which purpose it was designed) having only 1 stage of A.F. amplification; but in the present instance, where 4 stages are used, not even the slightest trace of commutator ripple can be tolerated in the voltage amplifier stages or the biasing voltage to the phototube. No luck at all was had with attempts to apply vibrator types of eliminators to this particular unit, although it is possible that such a unit can be obtained which will be found to be satisfactory.

List of Parts

PROJECTOR AND RECEIVER HEADS

One special midget dynamic speaker unit with 6 V. field and transformer for type 41 tube;
One small automobile spot light in which the bulb can be focused;
Two condensing lenses, 6 ins. in dia., plano-convex;
Eight pipe ells, $\frac{3}{4}$ -in.;
Eight pipe nipples, $\frac{3}{4}$ x4 ins.;
Two pipe tees, $\frac{3}{4}$ -in.;
Two reducing couplings, $\frac{3}{4}$ x $\frac{3}{4}$ -in.;
Two pipe flanges, $\frac{3}{4}$ -in.;
Two lengths pipe, $\frac{3}{4}$ -in., sufficient to mount projector and receiver heads to desired height;
One length stove pipe, 7x24 ins.;
One haseboard, 1 1/2x7 1/2x24 ins.;
Prestwood for sides and lens mountings;
Flat black paint;
Brass or copper sheet, 1/16-in., for light gate;
One 4 prong tube socket;
One Sylvania type 868 photocell.

AMPLIFIER

One carbon resistor, 1/2-W., 1 meg., R1;
Seven carbon resistors, 1/2-W., 50,000 ohms, R2, R3, R8, R10, R13, R15, R17;
Five carbon resistors, 1/2-W., .25-meg., R7, R9, R12, R14, R16;
Two carbon resistors, 1/2-W., .5-meg., R6, R18;
Two carbon resistors, 1-W., 2,000 ohms, R4, R11;
One carbon resistor, 2-W., 600 ohms., R19;
One carbon resistor, 1/2-W., 30,000 ohms, R5;
One volume control potentiometer, .25-meg., R20;
Four Concourse paper condensers, .006-mf., 600 V., C1, C2, C3, C4;
Eight Concourse paper condensers, .25-mf., 200 V., C5, C6, C7, C8, C9, C10, C11, C12;
Three Concourse type C-4 dry electrolytic condensers, 4 mf., C13, C17, C18;
Three Concourse type PTW-10 dry electrolytic condensers, 10 mf., 25 V., C14, C15, C16;
One Concourse paper condenser, 1 mf., 200 V., C19;
One 30 hy. filter choke, L1;
Three 6 hole sockets;
Two glove type shields for ST12 bulb;
Two screen-grid clips;
Two double tip jack units;
One single-open-circuit phone jack;
One double-pole, double-throw jack type switch, S1, S2;
One heavy current type switch, S3;
One binding post strip having 6 connections;
One I.C.A. Electroloy chassis, 6 1/2x10x2 ins.;
One Carter Super Genemotor, model 1580-A;
One Universal Model QRXF microphone, complete with input matching transformer and volume control;
One flashlight cell for above;
One Sylvania type 77 tube;
One Sylvania type 79 tube;
One Sylvania type 41 tube.

A NEW HIGH-FIDELITY DUAL-CHANNEL AMPLIFIER

(Continued from page 151)

For the benefit of those who like to hear plenty of lows at all levels, and in order to compensate for the loss of lows at low volume levels, a bass "booper" circuit has been incorporated in the low channel. When this circuit is used, the harmonic content of the extreme lows (60 to 100 cycles only) is increased slightly, but it is not at all objectionable to the ear.

Baffle Data

One more fact must be kept in mind about loudspeakers in connection with high-fidelity reproduction, and that is the correct use of a baffle. The sole purpose of a baffle is to act as a shield or partition (not a sounding board) to prevent the sound waves radiated from the back of the speaker from cancelling those radiated from the front.

The shortest distance, from the center of the baffle opening in the front and around the baffle edge to the center of the speaker in the rear, must be one-fourth of the wavelength, in inches, of the lowest sound frequency that is to be reproduced without noticeable attenuation (e.g. one-fourth of the wavelength of 70 cycles is 54 inches). This applies particularly to a flat baffle, though a cabinet follows approximately the same rule. This formula also holds true for any dynamic speaker when used as a low-frequency reproducer, assuming, of course, that the speaker itself will reproduce these low frequencies. A high frequency horn-type speaker, however, requires no baffle, because there is no backward radiation, though it may be placed in the same baffle as the low-frequency speaker without affecting the response of either speaker.

Construction

Figures A, B and C show the completed experimental amplifier, the layout of which is more or less standard. It may be suggested, however, that in order to reduce hum to an absolute minimum, the power supply be built as a separate unit, on its own chassis, if this is at all possible. However, it is not an indispensable requirement. In connection with hum (due to the large number of transformers in the amplifier and the excellent response curve at low frequencies) it is quite necessary to mount T1, T2, Ch.2 and L3 in such positions that the hum picked up by them is at a minimum. It might even be found necessary to re-shield them individually. In fact, care must be exercised in the placement of all parts and leads in order to minimize hum and feed-back.

Construction of the unit may be determined by reference to Figs. A, B and C, and the circuit diagram in Fig. 2. However, a few comments are added.

The low-pass filtering system for the low channel is accomplished by means of Ch.3, R12 and C10. The results are shown by the frequency response curve of the low channel above 800 cycles. This cut-off could be made more abrupt, but since the low-frequency speaker efficiency is "down" at high frequencies it was found inadvisable to incorporate a more complicated filter herein. Unit Ch.3 is a 30 Hy. choke that has been reduced to 15 Hy. by removing the lamination shell, substituting a new paper shim about .025-in. thick for the original shim (the original one is about .006- or .008-in. thick), and then replacing the shell.

When the bass "booper" circuit, Ch.2, C5, R6, is removed (by making R6 zero) the bass response is "held up" by the resonant circuit R12, C14, T5, C11, and the bass response of the low channel is shown by curve A on Fig. 2. As R6 is increased, the bass response becomes more nearly B, and finally becomes B when R6 is wide open. Incidentally, if one cares to move the peak, at B, up the frequency scale, it may be done by simply decreasing the value of C5 (.03-mf. moves the peak to about 100 cycles), or to move the peak to a lower frequency, simply increase C5.

In the high-frequency channel the high-pass filtering is accomplished by means of C2, C4, C8, C12, Ch.1, T3, with the results shown by curve A'-A' on Fig. 3.

The normal response of the high-frequency channel is shown by the curve A'-A'. By rotating

C15 slowly in a counter-clockwise direction, the curve becomes A'-C', then A'-C'', etc. This allows the listener to adjust the extreme high-frequency cut-off to suit the operating conditions. Resistor R3 varies the level of the entire high channel independently of any adjustments to C15. The listener's ear alone can determine the correct setting of the high-frequency channel level, but it may be said that many weird sound effects can be produced with this control.

It will be noticed that in both channels all "B+" leads are well filtered (C6 and R7, C11 and R13, C7 and R8, and C13 and R11). This is quite necessary in order to prevent feed-back between stages due to the high gain of the amplifier.

Units S1 and S2 are both 4-prong sockets from which the leads for the low- and high-frequency speakers respectively are brought out (2 voice coil, and 2 field leads).

Additional Features

A 200 ohm input is provided as well as the regular high impedance input. The 200 ohm input may be used for phonograph or microphone, or a 200 ohm line input. A regular carbon microphone will give plenty of volume when used with this amplifier, but ordinarily the quality will not be as good as with a dynamic or condenser microphone. However, the latter two types will require additional pre-amplifiers.

The 200 ohm output winding in the low channel serves two purposes where true high fidelity is not required (response: 30 cycles to 5,000 cycles). It may be used for phonograph recording, or for a remote reproducer (which may be a permanent-magnet type). In either case switch S2 is thrown so that the low-frequency voice coil circuit is opened and choke CH.3 is shorted out. The high channel is then simply turned off. The use of the low channel only with its 5,000 cycle cut-off for phonograph recording is justified by the fact that only the most expensive pickups record above about 4,000 cycles, and also because a speaker's efficiency at high frequency is not a factor.

Socket S3 is a 6-prong unit to which the filament leads X-X and the "B+" ground, plus two input or "B+" leads (if desired) are connected so that power may be obtained to run a tuner for the amplifier if desired.

The author will be pleased to receive any comments or questions concerning this amplifier.

List of Parts

One metal chassis base 3x10x23 in.;
Five 4-prong wafer sockets, V5, V6, V7, V8, V9;
Two Na-Ald type 434 4-prong sockets, S1, S2;
Four 5-prong wafer sockets, V1, V2, V3, V4;
One Na-Ald type 436 6-prong socket;
Two twin-tip jacks, J1, J2;
Two binding posts, "Input," BP1, BP2;
One S.P.D.T. toggle switch, Sw.1;
One D.P.S.T. toggle switch (open one circuit—close one circuit), Sw.2 (a D.P.D.T. switch may be substituted);
One S.P.S.T. toggle switch, Sw.3;
One Electrad type RI-242 tapered potentiometer, 0.1-meg., R1;
One Electrad type RI-203 tapered potentiometer, 0.5-meg., R2, R3;
One Electrad type RI-206 tapered potentiometer, 1. meg., R6;
Four IRC resistors, 3,000 ohms, R4, R5, R9, R10;
Two IRC resistors, 10,000 ohms, R11, R13;
Three IRC resistors, 25,000 ohms, R7, R8, R14;
One IRC resistor, 50,000 ohms, R12;
One Ward-Leonard resistor, 20,000 ohms, R15;
One Aerovox pigtail mica condenser, 400 mmf., C10;
One Aerovox pigtail mica condenser, 500 mmf., C2;
One Aerovox pigtail mica condenser, .002-mf., C8;
One Polymet condenser, .05-mf., 600 V., C5 (see text);
Three Polymet condensers, 0.1-mf., 300 V., C1, C4, C12;
One Aerovox condenser, 0.25-mf., 300 V., C14;
One Aerovox condenser, 0.5-mg., 400 V., C16;
Eight Aerovox dry electrolytic condensers, 8-mf., 500 V., C6, C7, C11, C13, C17, C18, C19, C20;
Two Concourse dry electrolytic condensers, 30-mf., 25 V., C3, C9;
One tone control, C15;
One General Transformer 200-ohm line-to-grid transformer, T1;

The BEST was required — WRIGHT-DECOSTER was chosen!

THE Hollywood Concession at "A Century of Progress" was extensively representative of the sound and motion picture industry. They chose Wright-DeCoster speakers in 1933 and definitely specified that nothing but Wright-DeCoster speakers should be used at their concession in 1934.

A model 309 full range reproducer and horn will improve the sound in any theatre. If it does not it may be returned and the money fully refunded. Write for full particulars.

They will ask you "when did you get your new radio?"

Any automobile radio set can be improved by installing a

*Model 245
Vehicle Speaker*



245 Vehicle Speaker \$15

We sell this speaker with the understanding that it may be returned and your money fully refunded if you are not pleased in every respect.

Be sure and state type of output tube or tubes when ordering your sample.

Are you a Wright-DeCoster user? If so, are you receiving our monthly sound letters?

WRIGHT-DECOSTER, Inc.

2251 University Avenue
St. Paul, Minn.

Export Dept. M. Simons & Son Co.,
25 Warren St., New York.

Cable Address: Simonrite, New York

SERVICEMEN!
THE MOST COMPLETE LINE OF CONDENSERS
AND RESISTORS FOR EVERY RADIO USE
Write for our new 10-page Catalog folder free of charge

AEROVOX
CORPORATION

76 Washington Street Brooklyn, N. Y.

ALUMINUM PANELS
16 Gauge 7x12, 28c; 7x11, 32c;
5/64 inch or 13 Gauge 7x10, 29c;
7x12, 34c; 7x14, 41c; 7x18, 49c; 7x21, 68c

These panels are a special lot at the above prices. Longer and wider at correspondingly low prices. Add postage on 2 lbs. for each. We have no catalogue. Radio parts for over 10 years.

BLAN THE RADIO MAN, INC.
177 Greenwich St., Dept. Y, New York, N. Y.

LOWER PRICES Consistently

ALLIED RADIO

AGENTS WANTED!
MOTION PICTURE SOUND
Most fascinating field awaits live Radio Service
Men—quick, sure profits
ASK FOR FREE CATALOGS
S.O.S. CORPORATION
1600 Broadway New York, N. Y.
Cable Address: "Sosound" New York

192 PAGES of
SHORT-WAVE and
P. A. DATA - only 50c

TRY-MO RADIO CO., INC.
85-C Cortlandt Street New York

10 HOURS
of Reading Pleasure

Five Stirring Stories of
Future Science in Current Issue

WONDER STORIES brings to its readers vivid, thrilling, and absorbing tales of adventure on alien planets—stories of biological monstrosities, time-travel, the future civilizations of man, and other educational science-fiction themes.

Here is the contents for September: THE FALL OF THE PIPPEL TOWER by Charles de Richter, THE MAN FROM BEYOND by John Reyon Harris, THE LIVING GALAXY by Laurence Manning, THE TREE OF EVIL by David H. Keller, M. D., and ENSLAVED BRAINS by Eando Binder—plus several interesting departments. The voice of the SCIENCE FICTION LEAGUE.

SPECIAL OFFER (in U.S.A. only)—One year for \$2.00. Send check or money order.

WONDER STORIES, 99-R Hudson St., New York, N. Y.

Be Your OWN Doctor!

This new monthly magazine is also your own doctor. WHAT AHS YOU? POPULAR MEDICINE tells and advises you thoroughly. Written for you by doctor. Non-technical, yet authoritative for all laymen. Many anatomical illustrations. At all newsstands.

Special Offer!
8 Months for \$1
Send 25c for sample copy

POPULAR MEDICINE
97R Hudson St., New York, N. Y.

- One General Transformer interstage transformer, T2;
- One General Transformer interstage transformer, T3;
- One General Transformer push-pull input transformer, T4;
- One General Transformer push-pull input transformer, T5;
- One class B power transformer, 480-0-480 V., T8;
- One filament transformer, T9;
- One choke, 5 hy., Ch.1;
- One choke, 500 hy., Ch.2;
- One choke, 30 hy., Ch.3 (see text);
- One choke, 8 hy., 250 ma., Ch.5;
- Four Raytheon type 56 tubes, V1, V2, V3, V4;
- Four Raytheon type 45 tubes, V5, V6, V7, V8;
- One RCA type 523 tube, V9;
- One Wright-DeCoster high-quality speaker, including output transformer T6, and a 300-ohm field coil, Ch.6;
- One Wright-DeCoster high-frequency speaker, including output transformer T7, and a 200-ohm field coil, Ch.4;
- Miscellaneous wire, nuts, bolts, etc.

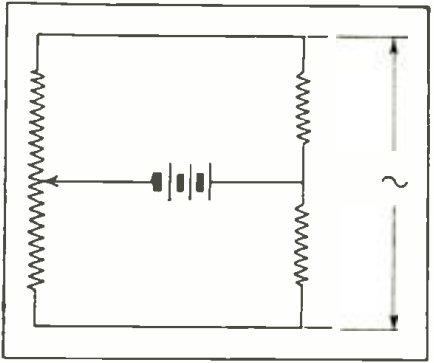

Fig. 2
Equivalent circuit action of the unit.

NEW P.A. EQUIPMENT

(Continued from page 155)

the best time to make such installations. On this page are shown some modern devices which will aid the P.A. man to close sales and make a profit at his task of installing equipment. Perhaps the most important feature of this newly designed portable P.A. system is its ready adaptability to such a wide variety of uses, both in and out of doors. When used in a large theatre or auditorium, and employing the two speakers which are furnished as standard equipment, it will easily cover a 3,500 gathering. For outdoor meetings etc., this portable system will reach every person with a clear-cut and faithful reproduction of either voice or music. Outdoors, it has a coverage of 2,500.

To guarantee the utmost in pickup efficiency and frequency response, a condenser microphone with a neatly designed built-in head amplifier is employed as shown in the illustrations. The power supply and amplifier for this new P.A. system are housed in one small metal case, and to eliminate any possibility of incorrect hook-up, all connecting plugs are polarized.

The speakers employed in this system are housed in newly designed all-aluminum baffles which permit better coverage and greater efficiency than the old box type baffles previously used. The speaker baffles are mounted on adjustable standards, and can easily be removed for mounting on walls if necessary. The speakers can be swiveled from side to side and can be raised and lowered on their adjustable standards. The standards are designed and constructed exactly like the floor stands ordinarily used with all types of microphones.

The efficient manner in which these units have been designed and constructed permits easy installation of either the permanent or temporary types. Also all of the parts are carefully protected against outdoor weather conditions.

With these devices a P.A. man can make an installation in materially less time than required with previous units and in this business it is well known that *time is money*.

Figure 1 shows a cross-section of the pickup, from which its simplicity can be readily seen. The oxide crystals provide the resistance element, which resistance varies with the pressure, approximately between 40,000 and 500,000 ohms. The output of the pickup will mainly depend on the voltage applied across this resistance. Although 25 volts is enough to obtain a large output, 250 volts can be used without burning or baking the oxide crystals. The pickup in construction, is very similar to a double-button microphone. That is, it consists of 2 resistance elements that simultaneously vary in the opposite direction. (The resistance of the crystals in one cup is increasing while the resistance of the crystals in the other cup is decreasing.) These 2 elements can be used in the case of push-pull output tubes. In the case of single-tube output, only 1 element (cup) is used and gives equally good performance. The voltage and current—less than 1 ma.—is obtained from the "B" supply. This small current can hardly be considered a drain, even on battery-operated sets. Figure 2 shows the equivalent circuit of the pickup. Figure 3, the simplest method of connecting to any radio set regardless of make, model or year of manufacture. The pickup is always connected to the tube preceding the power stage.

The construction of the pickup unit is a radical departure from the magnetic type. (1) It is simple and rugged. (2) Proper dampening makes it possible to eliminate all resonant peaks—such peaks are the cause of poor reproduction. (3) Contrary to the magnetic pickup, the response does not fall at the lower frequencies but shows a marked rise. It is, therefore, unnecessary to use filters or any additional apparatus in the amplifier of the radio set to obtain the lower frequencies. The reproduction is not mechanical—but real. The combination of the radio set and pickup give a straight-line output.

The die-cast construction eliminates tone arm resonance. Ball-bearing pivots give free motion to the arm resulting in perfect tracking. Long record life is obtained by the exceedingly low weight on the record—less than 2 ozs. (magnetic units, for the same bass response, require a pressure of 3 ozs. and more).

A NEW COPPER-OXIDE PHONO. PICKUP

(Continued from page 155)

copper oxide; the average resistance of the pickup is approximately 0.1-meg. No background noise whatever is developed. Its high resistance makes it possible to connect it directly into any radio set without any changes whatsoever. The operation of the set itself is not affected in the least.

This unit operates as a resistance that varies according to the motion of a contact arm which is rocked by the needle. This "variable resistor" modulates a steady D.C. potential that flows through it. The modulated voltage is applied to the grid of the output vacuum tube.

READER'S DEPARTMENT

(Continued from page 160)

Without going into detail, all or any of the faults in a radio receiver can generally be traced or diagnosed by asking the owner a few questions, as to how the receiver stopped (if it is "dead") or how the trouble developed—that is, did the effect occur suddenly or was the operation of the set gradually growing worse for some time? With this information under his belt the Service Man should be able to locate the trouble in a very few moments. If a part must be replaced, do so with a genuine good part (by the original maker if possible), for money saved by buying poor parts is a poor profit that will, in time, ruin any shop's reputation. Better do a good job and charge a good price; the result will be a satisfied customer, who will call you in again.

I do not intend this letter to instruct as to how various sets are tested or how various troubles are located. There are many books on

that subject (some are good and some are good for nothing), but I intend to convey the idea that, in actual servicing, the job is usually to restore a receiver to the condition in which it was when the customer bought it and to do that does not require a large assortment of apparatus.

Of course, if the customer asks to have improvements made on a receiver then, and then only, is there reason to have a little excess equipment but, taking everything into consideration, there are very few cases where an improvement can be made that the cost would not be prohibitive—and probably a new receiver could be bought for little more than the cost of the improvement, which would perform better than the improved set!

I write this letter simply to convey my idea of what would help the business of servicing radio receivers (somewhere in your magazine you asked for criticism, so here I am giving it). I do not intend to criticize the article mentioned above, neither do I approve it, but I feel that equipment is given too much of the spotlight.

EDWARD J. MONTAGUE,
104-15 35 Avenue,
Corona, L. I., N. Y.

This is our idea of a constructive criticism. If a few more technicians will exhibit the courage of their convictions and send us their comments for publication, maybe the radio trade will take the hints to heart.

Although we agree with Mr. Montague's remarks, as he presents them, we wish to call attention to a few points in policy that were not obvious in the first part of the article, "Uplifting the Servicing Profession" (RADIO-CRAFT, June, July, August, 1934).

Modern test equipment has been so simplified and improved, and the directions that accompany them are so complete that inexperienced radio men are enabled to secure much better results through their use than would be the case were it necessary to use less efficient units in a servicing procedure that depended mainly upon experience for its success.

Again, experienced technicians realize the improvements that have been incorporated in modern test equipment, and are able to apply to full advantage the more efficient technique which these design improvements afford.

Finally, as stated in Part III (which Mr. Montague had not seen when he wrote to us), the display of comprehensive test equipment has a psychological effect that has a great way of attracting attention which turns from interest to orders.

A VOICE FROM "DOWN SOUTH"

Editor, RADIO-CRAFT:

Are the radio fans without electric current going to be forgotten? There are lots of these still alive—"believe it or not." Auto sets have their share of help, but what about the fellow who has to stay at home?

The battery sets today are not near so expensive as they used to be to operate, mainly because of the tubes used. The 2 V. tubes are a good example, and the ones of the 6.3 V. auto-radio type are not near so thirsty for that old "A" current as were some of the older type tubes. Almost any type of tube can be had in this line too, and if you don't believe there is plenty of pep in them, just give them a try.

The market was flooded with little A.C.—D.C. sets last winter and some of the owners quit using them after the novelty wore off. Lots of them are never repaired after they once give trouble. They may be bought second-hand from a radio Service Man or shop, very cheap. Many of these sets were equipped with a plug for storage battery use; in lots of cases this was very expensive, though, on account of the "B" batteries. This was especially true if the dynamic speaker received its current for the field from the "B" batteries, when they would last only a short time.

These little sets can be changed for either dry battery or storage battery use at very little cost for change-over and maintenance. Practically all of the parts to be used are found in the original set. Only the circuit needs to be slightly changed in a few places. The filament should be completely rewired and all other wires, except the ones from the coils, removed

before beginning work. The circuit for battery operation can be easily checked against the original A.C.—D.C. diagram. A circuit for use with a storage battery "A" supply is shown. There is nothing unusual about it. A good quality magnetic speaker should be used. If the original cabinet is used, transformer T. can be mounted on the back of the chassis. (I used an old portable victrola case for the set. This gave room for batteries also, and made a fine portable.)

ALVA H. CLARK,
Linden, N. C.

FROM ACROSS THE CANADIAN BORDER

Editor, RADIO-CRAFT:

I noticed in Operating Notes for May, 1934. Mr. Lamb states that he has not had any trouble with the 2 mf. condenser in the 201 Stewart-Warner converter.

I understand that this condenser is rated at 400 V., but I have come across a good many sets with a 200 V. condenser and in nearly every case the condenser has developed a total short-circuit—in most cases, with the 25,000 ohm dropping resistor burned entirely out; in two recent cases the 8 mf. electrolytic filter condensers in the broadcast set also shorted.

I think the 200 V. condensers were installed in the Canadian factory only; that is why the trouble has not appeared in "the States." As most converters have 250 V. it is no wonder the condensers give out. Installation of a 2 mf. electrolytic condenser effectively cures the trouble.

I have also found that reduced volume can be directly traced to faulty switches; this can easily be proven by connecting the aerial wire directly to the coil. If the volume increases the switch is defective. I have taken these switches apart and cleaned the contacts and brought reception back to normal but it is a ticklish job and a new set of switches is the better plan. I have increased volume by going over the entire set with a soldering iron and resoldering every connection. This applies to all short-wave receivers.

I have found that no reception in the Stewart-Warner 102 was often caused by open-circuiting of the wire-wound 5,000 and 6,000 ohm resistors.

WILLIAM NYE,
Stewart-Warner Sales & Service,
Ottawa, Canada.

BOOK REVIEW

SO-O-O-O YOU'RE GOING ON THE AIR! (first edition), by Robert West. Published by Rodin Publishing Co., Inc. Size 8¼x5½ ins., cloth covers, 215 pages. Price, \$1.75.

This book is the first comprehensive treatise on the subject of broadcasting from the angle of the artist that your reviewer has seen. All those who have ambitions to stand before that terrifying ogre—the broadcast mike should find much useful information contained in it. An idea of the scope of this book can be gleaned from the headings on a few of the chapters—"Gags—Begged, Borrowed and Stolen; Writing Radio Comedy; Music for the Multitude; The Cult of the Announcer; Building of a Program; Future of Radio."

The author is a well known authority in the subject of correct speech and is well fitted for the task he has "tackled." The material in this volume is written in a clear concise style that makes interesting reading as well as instructive data. Practically every phase of the field has been touched on and important facts have been explained in detail.

An outstanding section in the book is "the radio speech primer" which tells in simple, precise language how to speak into the microphone, develop a mike technique and hold a radio audience. While this book cannot make an embryonic musician, comic, public speaker or other radio entertainer into a star, it presents many facts which, correctly applied will do much toward achieving this end.—CWP.

New RADOLEK 1935



148 PAGE CATALOG

Is Now Ready

- Listing Over 6000 Parts, Sets, Tubes, Amplifiers, Tools, and Test Instruments Readymade or in Kits.
- Over 200 Diagrams! Complete Volume Control Guide. A New, Modern Tube Index with Bias Resistor Values, Transformer Replacement Data.
- Many New Devices! Exclusive Radolek Inventions in Kit and Finished form.
- Power Amplifiers! As Complete Outfits in Kit and Laboratory Made Units.
- Lowest Prices! High Quality at the Lowest Prices You Have Ever Seen for First Class Merchandise.
- If You've Changed Your Address since receiving our 1933 Catalog, or if you have not received a catalog from Radolek recently, send us your business card or letterhead immediately! Our Catalog Is Strictly Wholesale for Members of the Trade.

The RADOLEK Co.
Dept. RC, 601 West Randolph St.
Chicago, Illinois

100 Kilocycles to 21 Megacycles



The new Model 61 All-Wave Oscillator is designed to cover a frequency range from 100 kilocycles to 21 megacycles. Tuning is by means of a precision dial. Each Oscillator is laboratory-calibrated and supplied with a tuning-chart, hand-drawn to an accuracy of one-half of one percent.

Write for complete catalog

Supreme Instruments Corp.
501 Supreme Bldg. GREENWOOD, MISS.

SOUND MEANS PROFITS

See Page 183

ALLIED RADIO

REFRIGERATORS SERVICE ELECTRIC

In your community there are dozens of electric refrigerators to be serviced. Many need immediate repairs which can be made quickly, with little expense—and which you can repair with the aid of this authoritative Refrigeration Service Manual. Make many extra dollars, together with other repair work, Electric refrigeration servicing is a well-paying business—start in your spare time—before long you will devote full time to it. One or two jobs pay the small cost of the OFFICIAL REFRIGERATION SERVICE MANUAL.

96 Pages of New Data Have Been Added to the OFFICIAL REFRIGERATION SERVICE MANUAL

To bring this useful service manual right up-to-date, Mr. L. K. Wright, the editor of the OFFICIAL REFRIGERATION SERVICE MANUAL, has added a wealth of material on new electric refrigerators, and older models as well. As usual, every refrigerator has been accurately described from the viewpoint of servicing—diagrams to illustrate the essential parts, so simplified that repairs can easily be made. The addition of these new pages will not increase the cost of the book to those who order their copy now.

Here Are Some of The Important Chapters:

- Introduction to the Refrigeration Servicing Business
- History of Refrigeration
- Fundamentals of Refrigeration
- Description of All Known Types of Refrigeration Motors
- Trouble Shooting
- Unit Parts, Valves and Automatic Equipment
- Makes and Specifications of Units
- Manufacturers of Cabinets
- Refrigerants and Automatic Equipment and Many Other Important Chapters



Over 1,200 Diagrams
450 Pages
Flexible Looseleaf Binder
Complete Service Data

Mail Coupon Today!

GERNSBACK PUBLICATIONS, Inc. RC-934
99 Hudson Street, New York, N. Y.

I enclose herewith my remittance for \$5.00 (check, stamps or Money Order accepted) for which you are to send me, POSTAGE PREPAID, one copy of the OFFICIAL REFRIGERATION SERVICE MANUAL, together with the extra 96 pages of new material at no extra cost.

Name.....

Address.....

City..... State.....

THE OPERATION OF BROADCAST NETWORKS

(Continued from page 143)

master-control room in the headquarters of WABC, Columbia's key station—one of the largest operating crews ever assembled for a broadcast. He was in constant 2-way communication with numerous land, sea and air observation posts by means of an auxiliary short-wave circuit. As emergency set-ups of this nature ordinarily operate on the thin edge of speech intelligibility, any slight imperfection in the pickup would have impaired the program, but which turned out to be a tribute to chain broadcasting.

The 7,500 to 8,000 cycle band used by certain cleared-channel stations is utilized, and line transmission facilities are taxed to the utmost in certain pickups that feature the international slant. An excellent example was the recent CBS transmission over WABC, New York, in which the microphone was installed in a telephone exchange in San Francisco's Chinatown! The telephone numbers—or sometimes merely the names of the subscribers!—were shown by Loo Kern, Chinese manager of the exchange, to be called for in any one of 7 Chinese dialects!

Still another type of voice transmission, which requires for its efficiency the utmost fidelity in the entire network system, was the recent Chicago stockyards holocaust. The tensely gripping eye-witness story as told from atop the Illinois Bell Telephone Company's building, a half-block from the huge fire, was transmitted with all the spontaneous shadings of sound incident to the broadcast of what was a veritable national calamity. It was from this point that Chief Field Marshal Michael Corrigan told the world that the fire was under control.

Then there is that most remote of remote pickups, the Byrd Antarctic Expedition broadcasts from Little America, over 9,000 miles from New York, a half-hour program for which General Foods pays over \$7,000. Every artifice is used to secure perfect pickup, via Buenos Aires, S. A., and South Schenectady, N. Y. Radio and telephone engineering were recently put to a crucial test to present to the audience of the 59 stations in the Columbia network the voice of Admiral Richard E. Byrd, as he flew in his airplane aloft the Antarctic Ice Cap!

However, although this was a record-breaking achievement in radio, the most brilliant jewel in the crown of radio broadcast network operation was the coast-to-coast tie-up of over 600 broadcast stations in a recent Presidential address to the people of the United States! Complete coverage of the entire country, from a desk telephone in Washington, D. C.!

Inasmuch as our entire American broadcast structure depends for its efficiency upon the "mass" coverage that can be obtained by network operation, it follows that the thousands of miles of wire, and associated apparatus, required to join one station to another, constitute a most important link.

"Telephone" and "Broadcast" Cables

A telephone message circuit, such as Banker Smith would use in talking to New York and Chicago, inclusive, passes through 19 telephone offices, where "repeaters" or amplifiers renew the electrical energy lost in transit through the cable. To minimize the energy loss, 1,500 "loading coils" are located in the circuit at intervals of 6,000 ft. The two terminal offices are equipped to terminate or switch the circuit. The equivalent of only 1 employee's full-time services maintains this telephone or "private conversation" circuit. The wires can be arranged to provide a "phantom" circuit by means of which an additional "talking circuit" is obtained without the use of additional wires.

A program circuit designed only for carrying radio programs from point to point, on the

Comparative operation of cables.

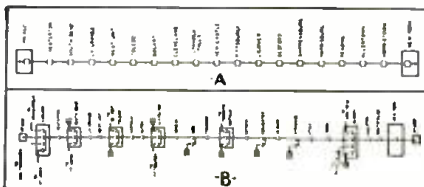

other hand, requires the use of larger and heavier wires than those used for telephone conversations. Also, owing to the exacting requirements of the broadcasting network service, loading coils must be installed at 3,000 ft. intervals. In addition, the special amplifiers employed for network purposes total more than twice as many as do the ordinary amplifiers or repeaters in the message circuit—40 as compared to 19. At 10 of the 23 offices through which the program circuit passes, provision must be made to feed the programs to radio stations, terminate the circuits or switch them. The equivalent of 15 technical employees' full-time service is required to maintain a program circuit! Furthermore, neither phantom nor carrier circuits can be operated in connection with program circuits.

For everyday telephony, a circuit which will transmit a frequency range of 3,500 cycles is generally sufficient for full intelligibility of speech. Circuits for entertainment purposes, however, require that a range of frequencies at least 8,000 cycles wide be transmitted.

Also, circuits designed for radio program transmission must be designed to take care of a considerable variation in volume or loudness. Otherwise, cross-talk, overloading of the equipment in the circuit which would produce "blasting" of the reproduction, and the production of undesirable frequencies would result.

Still another effect encountered in broadcast network operation is "delay distortion," due to the different degree of time required for the high and low notes to travel over the same copper-wire circuit. Correction circuits must be used to compensate the distortion which otherwise would result.

These limitations have been surmounted in circuits that operate over an audio frequency band of 5,000 to 8,000 cycles, for ordinary broadcast network requirements. Also, for special occasions ("Third Dimension in Music," RADIO-CRAFT, May 1934, pp. 654), transmissions have been made over a band of 15,000 cycles. And short-distance demonstrations have been given of cable transmission over a frequency band width of 45,000 cycles.

A New Era in Radio

Whereas the Federal Radio Commission was limited to operation in the radio field, the newly formed Federal Communications Commission will rule the largest group of communications companies in the world—including regulation of telephone and telegraph, as well as radio.

Surely, this new regime of coordinated effort promises radio programs both sustaining and sponsored, more desirable than any that have gone before. The first step has been taken in the granting of experimental licenses to four organizations desirous of developing the newly-opened "high fidelity" channels which permit operation on a frequency band 10,000 cycles wide. Practical work in this new field is scheduled to start in September. The writer witnessed the demonstration of third-dimension in music (and speech), and is in position to forecast that with the advent of high-fidelity transmissions radio will enter a new era of unprecedented popularity.

It does not take a wide stretch of the imagination to foresee the use of these wide-frequency channels for all broadcasting, after the first experiments have been completed. A review of technical developments in recent years aptly demonstrates the demands of the American people when they are educated to appreciate better things. And there is little doubt that after certain technical difficulties have been surmounted, the vastly superior quality possible with wide-frequency transmission will be in great demand.

AN INTERESTING BOOKLET

Every radio fan is familiar with the well known insulating material known as Bakelite. However, there are many other uses for this material than the panels, knobs etc., with which we are familiar. The manufacturer has just printed a most interesting booklet entitled "Bakelite Synthetic Resins for Paints and Varnishes." It is written in easy flowing, non-technical style and it contains so many interesting facts that we recommend it highly to all of our readers. A copy of the booklet can be obtained by writing to RADIO-CRAFT—ask for booklet No. 539.

"11 TUBE SUPER"

UNDER this title we described in the June 1934 issue of RADIO-CRAFT, page 734, an exceptionally efficient superheterodyne receiver. We now have available the following useful information concerning the aligning of the completed receiver.

This receiver is extremely sensitive and selective when correctly built and aligned and, therefore, its proper aligning must necessarily be a careful job. It can be done in ten minutes by an experienced man with proper equipment, but even the less skillful can make a good job with proper attention to detail.

Most servicing is done with a modulated oscillator and an A.C. output meter of low range shunted across the voice coil of the speaker. This is a good method and gives an audible signal which gives a good check on results. However, a better method, one which gives a much sharper indication and therefore allows more accurate aligning, is to use an unmodulated oscillator and a 0-25 milliamper, D.C. milliammeter in the common plate circuit of the tubes which are drawing variable current with signal intensity, namely, those which are fed through the tuning meter. Three methods of aligning are therefore given, No. 1, with unmodulated oscillator and D.C. meter, No. 2, with modulated oscillator and output meter, and No. 3, with no test instruments whatever. Method No. 1 is to be preferred, as the most accurate, No. 2 is good and No. 3 can be done with care and a fairly good result achieved.

Method No. 1. An I.F. oscillator, unmodulated, and calibrated accurately to 175 kc. is necessary. If the oscillator is the usual servicing instrument which is modulated by periodic blocking due to a high resistance grid leak, it can be quickly converted into an unmodulated one by shunting the leak with a fairly low resistance, about 25,000 or 50,000 ohms. This will disturb the calibration slightly (a few dial divisions), and the instrument must be recalibrated before it will be of use. The dial setting for 175 kc. must be known, the broadcast range is unimportant. 175 kc. can be spotted on the dial by using a harmonic of the oscillator beating against a known broadcast station. The simplest one to use is WLW on 700 kc. exactly and which can be heard at night over the entire North American continent. Tune a broadcast receiver to 700 kc., that is, tune in WLW at the best point. Couple the oscillator to be calibrated to the antenna input of the receiver and tune the oscillator around the previous 175 kc. point. A beat note will be heard in the receiver, which is the fourth harmonic of the test oscillator beating with WLW. Set to zero beat and dial setting on the oscillator will be 175 kc. exactly. This method of calibration is extremely precise and furnishes a convenient means of standardization at all times. Even manufactured test oscillators are often inaccurate in the intermediate frequency range and should be checked by the user before relying strictly on the curves furnished by the maker.

Now connect the 0-25 ma. meter in series with the tuning meter by breaking the lead to the red lead of the tuning meter. Connect a ground to the ground post of the receiver but disconnect the antenna. Remove the oscillator tube (the 56) from the socket. Connect the test oscillator ground lead to the ground post of the receiver and connect the high lead to the control-grid cap or clip of the first-detector tube. Now when the test oscillator is tuned through 175 kc. the milliammeter will swing down. Adjust the four trimming screws on the two I.F. transformers until maximum downward deflection is obtained (minimum current), going back and forth from one to the other until the best overall adjustment is had. Use plenty of power from the test oscillator to obtain a good down-swing, of about 3 ma. from maximum. You will find that very little adjustment is necessary as all the I.F. transformers have been set to 175 kc. by the manufacturer, although wiring and tube capacity may cause some very slight error.

Now remove the test oscillator and replace the 56 oscillator tube, and connect the antenna. You will note that as the receiver is tuned through a carrier, the meter will swing downward, just as before. This furnishes an accurate means of aligning the three trimmers on the

tuning condenser from known broadcast station frequencies.

Before proceeding further, be sure that the dial reads exactly 100 with the plates of the condenser full in. This is important. Now tune the receiver to the high-frequency part of the band, between 1,500 and 1,100 kc. and select a local station or a steady, strong distant station which is not fading. Referring to the calibration chart furnished, adjust the oscillator trimming condenser (rear section of gang) to make the station come in exactly on the dial setting corresponding to its frequency according to the chart. The peak should be found with the trimmer set well down but not tight. Now, without changing the dial setting, trim the other two circuits, the detector and R.F. stages, until a maximum deflection of the meter is obtained. Go over all adjustments again until the best peak is had. You will find that the adjustment of the R.F. and detector stages will be found with the trimmer set well out, but it should be possible to go through the peak. The receiver is now in exact alignment over the whole scale and the tuning should check with the chart to within half or one dial division. The alignment may be checked at the low-frequency end of the dial by re-adjusting the two front trimmers on a station between 550 and 700 kc. to see if a better deflection can be obtained but the improvement in deflection, if any, should be slight. It should not be necessary to bend plates in these sections. Of course, the receiver must be realigned at the high-frequency end of the scale if the adjustments are changed in checking the low-frequency end.

The test oscillator in the broadcast range could be used instead of actual broadcast signals for the gang alignment, but the usual test oscillator has considerable error in this range and unless it is carefully calibrated, errors will result which will make the calibration off. Station frequencies are much more accurate than those of any simple test oscillator.

Method No. 2. This is exactly the same as Method No. 1 except that the oscillator is modulated and an output meter is used for the peak indication. It is slightly less accurate than Method No. 1 since the A.F. output meter is always less steady and less precise in reading than that of a D.C. meter in the plate supply.

Method No. 3. In this method the I.F. transformers are not touched but their alignment is assumed accurate because they are correctly adjusted, within narrow limits, by the manufacturer. The tuning meter itself is used for aligning the three condenser gangs. As in method No. 1, a station is tuned in on the high-frequency end of the dial, the oscillator circuit trimmer condenser is adjusted until maximum tuning meter deflection occurs at the correct dial setting for this station and then the two other trimmers are adjusted to make this deflection a maximum. This method is quite good considering that it does not require any extra equipment and provides good alignment if the I.F. transformer trimmers have not been changed and the tuning meter is watched very carefully for slight changes in deflection during alignment.

RADIOLA 30

RECENTLY I was called to service a Radiola 30 which employs the R.P.A. 947 power unit. This type of power unit uses a type UV876 ballast tube in series with the primary circuit of the power transformer. Due to a blown condenser in the filter system, the ballast tube had been overloaded to such an extent that the heat cracked a feed wire within the tube, thus causing intermittent reception.

As it happened, one member of the owner's family was to take part in a program to be broadcast that afternoon and I had the job of getting the set to work before the program started.

To clear up the filter trouble was an easy matter, but to get another ballast tube was a sticker. After all attempts to get the tube had failed, I started to look around for a suitable substitute. I knew that a 30 ohm, 75 W. resistor would work, but even attempts to get that failed. Finally, I decided to try two 150 W. light bulbs connected in parallel. It was an anxious but happy moment when I turned the switch on and the set started to play as good as new. This arrangement also cleared up an old trouble common in this type of set—a noticeable drop in volume after the set had warmed up. CLINTON NILES.



Mr. E. H. Rietzke, President of CREI, former chief instructor at Naval Research Laboratory, and an outstanding figure in the Radio profession.

Service Men! THIS COURSE CAN MAKE MONEY FOR YOU!

... and it starts paying for itself right from the very first few lessons

My years of radio experience have made me well acquainted with the problems of the service man. I know that in no other profession is TIME so important. You are only doing so many jobs in a day—and it is your problem to make these jobs MORE PROFITABLE... or increase your efficiency to handle more jobs.

Practical Right From the Beginning

This course is so practical that you can start doing more jobs and make more money after the first few lessons... just a few extra jobs a week will pay for the entire course. Our Free Consultation is alone worth the price of the course. The engineering features are interpreted in terms of pure servicing practice. I can make you a SERVICE ENGINEER instead of a Service Mechanic. This course will make you money by saving you time.

FREE SAMPLE LESSON

"Audio frequency Amplification—Public Address Systems" will be sent without obligation at your request. Just ask for lesson No. 45.

SEND FOR FREE 40-PAGE CATALOG



CAPITOL RADIO ENGINEERING INSTITUTE

14th and Park Road, Washington, D. C. Dept. RC-9

RCA makes aerial history!

NEW ALL WAVE ANTENNA

"Provides a new source of profit for the wide-awake service man"—says A. H. Prow, Pres. Phila. Radio Service Men's Association.

EVERY home with an all wave set is an immediate prospect... so get busy! Tell your customers how this remarkable new antenna brings up weak signals, cuts down man-made interference, gives more uniform response because of special "double doubler" feature. Kit of essential parts retails for \$6.00. Your installation charge extra.

Special "Dealer Demonstration" Antenna Kit, Net Price \$9.85, makes possible convincing demonstrations in your store. Connects to four receivers.

Have you seen the remarkable new RCA Full Range Test Oscillator? 90 to 25,000 K. C. Direct Reading Dial, weighs 5 pounds with batteries. Only \$29.50



WORLD WIDE

ANTENNA SYSTEM

new-

"Get Acquainted"

Special Offer!

HERE is an opportunity rarely given to readers by a publisher. It is only natural that readers like to see a magazine, look it over carefully before they subscribe. You can NOW get your first copy of SHORT WAVE CRAFT under our "no obligation" plan. All that is required of you is to send fifteen cents, in stamps or coin, for a sample copy of a recent issue. When you receive it, read it over from cover to cover, decide that you want SHORT WAVE CRAFT every month . . . then you can take advantage of our special offer. Complete details are found in the coupon.

What SHORT WAVE CRAFT Contains

THIS popular short-wave magazine interests the great army of "hams," broadcast listeners, and general radio students who are interested in experimental as well as scientific angles of short wave development and application. In each monthly issue appears the largest and most correct short-wave station call list, and important construction articles, on receivers and transmitters, including "picturized" diagrams, easily understood by anyone, a big feature "originated" by SHORT WAVE CRAFT. You'll also find the latest news, about short-wave physics, micro- and ultra-short waves, and other applications of this newest branch of radio.

Many Short Wave Sets to Build

Many excellent short-wave sets with complete construction details with "picture" diagrams, are found in every issue—these sets vary from simple one- and two-tube sets to those of more advanced design, five and eight tubes.

Big Silver Trophy FREE!

Recently inaugurated by Mr. Hugo Gernsback, Editor, was the "Short Wave Scout Contest." To the Short-Wave "fan" who has looked and obtained verification of the largest number of short-wave stations from all over the world, during one month, will be awarded a magnificent silver Short Wave Scout Trophy.

Over 200 Illustrations
4-Color Cover
9" x 12"

25¢ The Copy



On All Newsstands

SHORT WAVE CRAFT, Dept. RC-934
99 Hudson Street, New York, N. Y.

Enclosed you will find my remittance for a subscription to SHORT WAVE CRAFT for
() One Year @ \$2.00 (Canadian and foreign \$2.50)
() Two years @ \$3.50 (Canadian and foreign \$4.50)
() SAMPLE COPY—15¢

Name

Address

City

State

(Send remittance in check or money order. Regulate letter if it contains cash or unused U. S. Postage Stamps.)

MAIL COUPON TODAY!

SERVICING THE 1930 RADIO SET MODELS

TO BEGIN our discussion, let us roughly divide into several groups some of the circuits widely used in the sets of 1930. We will group them according to the R.F. circuit arrangement, since it is here that the widest variation of design is apparent. We are confronted by several representative groups.

Low-Gain R.F. Circuits

Group one comprises R.F. circuits using types 26 or 27 tubes in neutrodyne (or variations of it) circuits. Using 3 or 4 tuned stages, transformer-coupled, fairly well shielded, and neutralized; and many using some form of frequency-response equalization—that is, providing for an increase in the response at the high-wavelength end of the dial. These circuits form the backbone of a number of receivers that have fairly high gain and selective R.F. circuits capable of delivering good-quality programs. Representative types of sets are the Majestic and Edison makes.

Medium-Gain R.F. Circuits

Group two are later-type circuits using mostly special type 27 tubes, 5 stages of R.F. amplification, pre-tuned input to the first tube, untuned interstage transformer coupling, and a very capable circuit arrangement. This group is represented by the Sparton, Day-Fan, Nelson and other Technidyne-licensed radio receivers.

High-Gain R.F. Circuits

Group three is composed of the receivers utilizing the type 24 screen-grid tubes, and 2, 3 and 4 stages of high-gain R.F. amplification. Band-selectors, pre-tuning, and tuned transformer coupling are also evident in the various circuit applications of this tube. Receivers manufactured by Atwater Kent, Crosley, Silver-Marshall, Amrad, Brunswick, Leutz, etc., are of this type.

Servicing "Screen-Grid" Sets

Because of the increased number of bias resistors, R.F. chokes, and bypass condensers, etc., the possibility of breakdowns in the materials used is greater in receivers that incorporate screen-grid tubes than in those which employ triodes. Higher voltages are the rule in screen-grid sets and, as can be expected, the extra grid connection complicates the actual wiring to some extent.

"Normal" Voltage and Current Values

For the Service Man who has not had much experience in servicing screen-grid types, average voltages, etc., as found in actual practice, will be given; also, some of the common ailments and causes.

In general, the Service Man should find approximately 165 to 185 V. on the plates of the R.F. screen-grid tubes. A "C" bias voltage of ½ to 2 V. on the screen-grid, as measured to cathode, is normal. On the filaments, 2.1 to 2.4 V., A.C. is usual. The average plate current is from 2 to 4 ma., depending of course on the age of the tubes.

Failure to obtain full voltage at the plate of any one socket denotes either a partial short-circuit in the plate feed wiring, a shorted filter condenser, or a shorted bypass condenser. In testing resistors which are bypassed by condensers it is usually quicker and more sure to disconnect the condenser, and test the resistor and condenser separately.

Sources of Hum and Circuit Oscillation

Loud hum, or low periodic hum (motor-boating) in the output usually indicates a partial or complete open-circuit in the control-grid (tuning) circuit, or bypass condensers in the plate or screen-grid circuit.

Quite contrary to some expectations, screen-grid sets may be subject to conditions which cause oscillation in the R.F. circuits.

W. H. SCHEPPELE

ULTRA-MIDGET RECEIVERS

IN THE cheaper midget receivers that have so flooded the market, trouble is often caused by capacity change in the compression-type trimmers. As these receivers consist usually of two T.R.F. circuits, it is a simple matter to replace one of the compression-type trimmers with a variable air tuned trimmer on the front panel, an arrangement with which satisfactory con-

tinuous balance can be obtained. The new control can also be used for fine tuning, adding greatly to the selectivity of the receiver—and this type of set needs it! As a service job, this is never worth less than \$1.50, and always makes a satisfied customer.

LOUIS J. SCHNEIDER

GENERAL MOTORS MODEL 170-E (Aircell)

AFTER having been in service from a year to a year and a half, the volume may drop off; or the set be dead. Upon testing, the "B" and "C" voltages will read O.K. The "A", with the tubes in their sockets, will read "0" volts; with the tubes out of their sockets a reading of 2 V. may be obtained. We have found it necessary to resolder all connections before the set will operate. This set will operate on a 2 V. storage battery, but volume will not be as great as when using an "aircell" battery.

CLIFTON S. KRUMLING

"SPRAY SHIELD" TUBES

HERE is an interesting service kink: in many old-style T.R.F. sets using a type 27 detector, hum can be greatly reduced by using a Majestic G-27-S or "spray shield" tube.

L. D. WILDER

WESTINGHOUSE 90

A PECULIAR case of fading was encountered in a Westinghouse Model 90 console super-heterodyne. The set would operate with good volume on the average station for about 15 or 20 minutes, then the volume would drop gradually until it was about 50% of its former value. After checking the set carefully I discovered that on the inner side of the wire-wound volume control resistance strip was a black spot about the size of the head on an ordinary straight, brass pin. On closer examination I noticed that 2 wires were burned through, partially opening the circuit. A new, 500 ohm wire wound resistance remedied this fault and the set operated perfectly.

The bakelite shell, metal shaft and sliding arm are usually in perfect condition on the older Westinghouse models so it is only necessary to replace the resistance unit, thereby netting the service man a quicker and more profitable job, as well as being able to charge the customer a small price for the job.

HARRY G. MITCHNER

ECHOPHONE S-4 AND S-5

IN CASES of acute loss of volume in the Echophone models S-4 T.R.F., and S-5 superheterodynes, the trouble can easily and quickly be remedied by replacing the 1. meg. control-grid bias resistor located on the resistor panel fastened on the side of the chassis of both models. Since the average Service Man does not have a voltmeter capable of measuring resistance of such high value, it would be quite difficult to locate this resistor which nine out of ten times causes the almost incomplete operation of the receiver.

One look at this midget chassis would almost certainly indicate that the replacing of this part would be "some job," but, on the contrary, it is quite easy if gone about in the right way.

On models S-4, first remove the two condensers which are bolted to the chassis alongside the resistor panel, and remove the two screws which hold the panel in its position, being careful to preserve the insulation sheet and large washers which serve to hold the panel a distance from the grounded chassis. Now, upon inserting the butt-end of a screw driver between the panel and the chassis, it will be found that the soldering iron can then be easily applied to the terminals holding the resistor in place (which in this instance is the white resistor, second from the left with the back of chassis toward you, on the bench).

In the S-5 models, the tone control assembly must be removed and the same procedure as given above followed (this resistor, however, being the third from the left of the panel).

The maker of these receivers uses porcelain resistors which do not hold up under the load and it is suggested that they be replaced with a good grade of carbon pig-tail resistor of the same value.

J. E. HARTMAN

GASSY TUBES

WE suppose most Service Men are familiar with the symptoms caused by gassy tubes although we have not seen much "dope" on the subject. A Philco 71 furnished an interesting example complicated by symptoms in both the A.F. and R.F. sections of the receiver.

The set would play for 15 or 20 minutes after it was turned on and then would fade, the fading being accompanied by distortion. Snapping the power switch on and off would restore reception for a few minutes.

The fading was finally traced to gassy 44s in the R.F. and I.F. int. stages, and the distortion to a gassy 43 in the 1st A.F. stage. The set has A.V.C. obtained by a varying bias applied to the control-grids of the R.F. and I.F. stages. These stages have the grid-return circuit resistors of high value which form a part of the customary decoupling filter. The A.F. stage also has a resistor of high value in its grid-return circuit in the form of a 0.5-meg. potentiometer used for manual volume control.

Apparently after warming up thoroughly the grid current became so large as to cause a voltage drop across the resistors in the grid circuits, finally causing the tubes to block. These tubes tested O.K. in a tester not equipped for gas tests.

A high-pitched A.F. howl in a Majestic model 90 was caused by a gassy type 45 in the push-pull output stage. The tube was so defective that it showed a blue glow at the comparatively low voltage used in the tube tester and glowed brightly when in the receiver.

Apparently the A.F. oscillations were due to an action similar to that of a neon bulb which may be used for an A.F. oscillator. (This type 45 had been in use for 4 or 5 years.)

HAROLD L. KRAMER

TEMPLE 8-80

A 9-TUBE Temple model 8-80 would operate for a minute or so and then the music would die away. The trouble was an open bias resistor in the 3rd R.F. stage.

Later on, this same model gave some trouble; the set didn't have any real volume even on a powerful station 25 miles away. The tubes were checked on a tester and seemed O.K., voltages, O.K., etc. However the 27 detector, after being in operation, seemed to be the cause of the trouble. The filament would light up as brilliantly as any of the others of that type but after a few moments of operation the incandescence of the filament would vary, always somewhat dimmer than when first turned on and cold to the touch. An "intermittent" filament was the trouble. A new 27 type remedied this, and the set performed O.K., with plenty of volume.

BOSCH CB 49

WHEN called in to service this receiver I found that the set was noisy at certain spots on the dial. I examined the wiping contacts on the gang condenser but they were O.K. Next I removed the shield can covering the variometer which is ganged up with the condenser through fibre gears and a wiping contact. I found that the contact spot was black, due to arcing in the set, and oxidation due to the use of natural gas for heating the house. I removed the variometer, being careful to mark the position of the two gears with a line so they would match up and mesh perfectly on re-assembly and also to guard against altering the tuning of the set (otherwise one will encounter a lot of trouble with this set), cleaned the wiping contacts with emery cloth and bent the contact arm to give it more tension after re-assembly and testing. The set tuned quietly over the entire dial scale.

STEWART-WARNER SERIES 50

THIS SERIES of Stewart-Warner comprising models 50 to 53 is an 11 tube all-wave receiver employing a double superheterodyne circuit with 4 tuning ranges. When this receiver is installed in a locality where a powerful broadcasting station is transmitting on a frequency of 1,500 kc. it may be noted that this station will be received all over the short-wave tuning ranges. This is due to the fact that the short-wave intermediate frequency is set at 1,525 kc.—entirely too close to the broadcast band. If the district distributor is notified of this condition,

instructions will be given to realign the short-wave I.F. trimmers at 1,525 kc. but in every instance this failed to produce the desired results. After a great deal of trial and experimentation it was found that after the short-wave I.F. had been realigned at 1,525 kc. to maximum output, it was necessary to throw the alignment out, by giving the middle trimmer a ¼- to ½-turn to the left (loosening the adjusting screw) while the interfering station, which may be even a nearby powerful broadcaster at 1,400 to 1,450 kc. is heard on any one of the short-wave bands. Of course, the harmonics of these interfering stations may be heard on the short-wave band, but this is normal.

Often, this receiver is very weak with the local-distance switch in the local position. Although the purpose of this switch is to eliminate noise while tuning from station to station, it is also possible to obtain greater response by realigning the broadcast gang trimmers, with the switch in the local position.

FREED-EISEMANN NR-78

RECENTLY I was called upon to repair a Freed-Eisemann NR-78. This set had a very loud, annoying hum. The trouble was traced to the filament wiring of the 27, the center lead having broken off the common terminal of the chassis.

SPARTON 930

A CUSTOMER called me the other day and complained of poor volume in his Sparton model 930. The two power tubes would only show 2 V. on their filaments. The trouble was traced to the hum control in this circuit. Instead of reading approximately 1 ohm, (with my ohmmeter) it was showing 25 ohms. The trouble was traced to the center lug of the variable control not making proper contact with the moving arm.

After soldering the lug to the case of this control, the filament voltage again read normal and my A.C. meter showed 5 V.

H. FRIEND

MR. LAMB'S PUBLIC SPEAKS

EDITOR, RADIO-CRAFT:

I have always considered the service DATA SHEETS as one of the most valuable items in RADIO-CRAFT and believe that Mr. Frank T. Lamb's suggestion on page 605 of the April, 1934 issue is excellent. Having a complete collection of RADIO-CRAFT as far back as the January, 1932 issue (which is not for sale), a quite elaborate system for indexing was necessary in order to have all information available when needed most.

A suggestion I would like to bring forward is the publication of an index in the last issue of a "volume." I am sure there are many readers who, like myself, have RADIO-CRAFT bound in volumes and a well-organized index would be a nice thing to have, even if the reader makes up one himself.

C. H. MIRTLE,
Sao Paulo, Brazil.

It will be observed that an effort is being made to arrange the DATA SHEETS in the manner suggested by Mr. Lamb and other readers.

There is available a publication entitled "RADIO-CRAFT Index by Subjects, Issues and Authors—July 1929 to June 1932" (the price is 25c per copy). An index covering subsequent issues may be available at a later date.

WHO'S WHO IN AMATEUR RADIO.

Published by Radio Amateur Publishers. Size 6¾ x 9½ ins., 144 pages, 142 portraits, paper covers. Price, \$1.00.

Without a Preface, Introduction, Contents, or any other preamble, this volume starts right off with a description of a First-District station, and its owner, and continues on through the numerical listing that is terminated by similar data pertaining to the foremost amateurs, and their stations, in the Ninth Radio District: concluding the book is an interesting listing entitled, "Radio Club Guide," followed by a listing of U. S. Inspection Districts, then, "International Abbreviations" concluding with some "Px, Tx and Wx Broadcasts."

BUILD YOUR OWN



Send for our new Catalog with the complete "Build Your Own" kit listings for world-beater All-Wave, Short Wave, and regular broadcast sets. Build our famous 2 tube "DX-er" described in the current issue of Short Wave Craft Magazine. Complete kit of quality parts costs only \$6.73 including coils. Anybody can build these simple successful sets inexpensively and get thrilling results.

SOUND MEANS PROFITS

Sell SOUND Equipment during these summer months for big profits. There's a wonderful opportunity in our single unit compact Mobile Sound Systems for complete operation from a 6 Volt storage battery. They're described in our new catalog along with a complete line of A. C. Amplifiers and Sound Systems ranging from 4 to 50 watts in output. If you sell SOUND, you need our book.



WORLD WIDE RADIO



Our new Catalog, which is yours FREE for the asking, lists the very latest All-Wave Superhets designed to tune 5 bands for World-Wide reception from 12 to 2540 Meters. These sensational performers are priced as low as \$30.85 complete in cabinet with tubes. Profit with our All-Wave and Dual Wave Sets. Send for our Catalog today!

FREE CATALOG

Write for the valuable new ALLIED Catalog. It's FREE. In addition to complete SET-BUILDING, SOUND and WORLD-WIDE SET listings, you will find radio's most complete stock of standard replacement parts and test equipment at consistently lower prices. Write Dept. D today for your Free copy.



Allied Radio CORPORATION

833 W. JACKSON BLVD., CHICAGO, ILL.

Train Now for New RADIO Opportunities

Get Into a Line

Where There's

Action—Every Day—

And a Payday Every

Week—You Be the Boss!

Analyzer & Resistance Tester—Latest Design—YOURS Without Extra Cost

Right now while hundreds are looking for work where there isn't any, the radio service field can use trained men. With the proper training and the necessary equipment, you can enter this field and make a comfortable living. We include with our course this modern set analyzer and trouble shooter without any extra charge. This piece of equipment has proved to be a valuable help to our members. After a brief period of training, you can take the set analyzer out on service calls and really compete with "old timers." We show you how to wire short-wave receivers—analyze and repair all types of radio sets—and many other profitable jobs can be yours. Teaching you this interesting work is our business and we have provided ourselves with every facility to help you learn quickly yet thoroughly. If you possess average intelligence and the desire to make real progress on your own merits, you will be interested.

ACT NOW—MAIL COUPON

Start this very minute! Send for full details of our plan and free booklet that explains how easily you can now cash in on radio quickly. Don't put it off! Write today. SEND NOW!

RADIO TRAINING ASSN. of AMERICA
Dept. R-9, 4513 Ravenswood Ave., Chicago, Ill.

Gentlemen: Send me details of your Enrollment Plan and information on how to learn to make real money in radio quick.

Name

Address

City..... State.....

TYPEWRITER BARGAIN

New **REMINGTON PORTABLE**

ONLY **10¢** A DAY



TEN DAYS TRIAL

Only 10c a day buys this latest model machine. Not a used or rebuilt typewriter. A beautiful brand new regulation Remington Portable. Standard keyboard. Carrying case included free. Try it in your home or office for 10 days. If you do not agree that it is the finest Portable at any price, return it at our expense. Don't delay.

FREE TYPEWRITER COURSE

Mail Coupon Today or Use Post Card

REMINGTON RAND INC.,
DEPT. RC-14, BUFFALO, N. Y.

Please tell me how I can buy new Remington portable typewriter for only 10c a day. Also enclose your new catalogue.

Name

Address

CLASSIFIED ADVERTISEMENTS

Advertisements in this section are inserted at the cost of twelve cents per word for each insertion—name, initials and address each count as one word. Cash should accompany all classified advertisements unless placed by a recognized advertising agency. No less than ten words are accepted. Advertising for the October, 1934, issue should be received not later than August 5th.

A. C. GENERATOR

10 PRACTICAL AND LOW-COST CHANGES converting Dodge 12-V., Ford T. A., Chevrolet Delco 6-V. generators into 100-500-watt capacity A.C. generators, or into 32-110-V., D.C. motor or generator. Dodge is 500-W. self-exciter. All in one book illustrated with complete simplified instructions and drawings for only \$1. Autopower, 410 S. Hoyne Ave., Chicago.

ELECTRICAL SUPPLIES

INSULATION, WIRE, VARNISHES, SUPPLIES, etc. Send 3c stamp for bulletin. Autopower, 410 Hoyne Ave., Chicago.

PATENT ATTORNEY

INVENTORS—Small Ideas may have large commercial possibilities. Write immediately for free book, "How to Obtain a Patent" and "Record of Invention" form. Delays are dangerous in patent matters. Free information on how to proceed. Clarence A. O'Brien, 533-F Adams Building, Washington, D. C.

It's Now 10c

EVERYDAY SCIENCE AND MECHANICS is the finest scientific-technical-mechanical-constructional magazine in the field. Up-to-the-minute with news flashes of scientific events. Dozens of constructional articles and many popular experiments. Ideas from which you can make things to sell.

A HOST OF INTERESTING SUBJECTS COVERED—Aviation—Woodworking—Astronomy—Patents and Inventions—Book Reviews—Metalworking—Chemistry—Engineering—Microscopy—Electrical Experiments—Lathe Operation—Shop Hints and other subjects.

\$1.00 FOR ONE YEAR

(Canadian and Foreign \$1.50). Send Check or Money Order.

EVERYDAY SCIENCE AND MECHANICS

99R Hudson St., New York, N.Y.

Over 150 Illustrations
10c the Copy On All Newsstands



INFORMATION BUREAU
(Continued from page 163)

TOO LOUD "LOUD SPEAKERS"

(282) Mr. Albert Beeds, Akron, Ohio.
(Q.) Does the Federal Radio Commission have the authority to prevent the use of loudspeakers which are reproducing radio programs? The writer is particularly interested in the instance where loudspeaker operation may become so loud as to be considered a public nuisance.

(A.) The Federal Radio Commission has made a statement in this connection which should completely answer this question, as per the following quotation:

"The Federal Radio Commission is primarily a licensing authority, empowered and directed by Congress to allocate radio facilities so there shall be, as nearly as possible, an equality of broadcasting service in the various states based on population.

"To improve the broadcasting service the Commission has adopted very rigid rules and regulations regarding the construction and operation of transmitters, and has clearly outlined its conception of the mandate in the Radio Act that stations must operate in the public interest, convenience, and necessity.

"While the Commission has dealt forcibly with all problems assigned to it, the general public is constantly appealing to this body for relief from grievances over which the Commission has no power.

"We have been petitioned by many 'distracted' listeners for relief from loudspeakers operating late in the night. Many complainants charge they are on the verge of nervous prostration, being unable to get needed rest.

"Because of the tremendous demand of the vast majority of the listening public, the Commission has designated the broadcast day as that period from 6 A.M. to 12 midnight. But, as some complainants point out, it is possible for a re-producer or 'loudspeaker' to be operated all night, giving further programs from distant stations, operating within their lawful time. Reducing the hours in the broadcasting day would not therefore solve the problem.

"So there is little or nothing the Commission can do about this matter under the circumstances, other than suggest to listeners that they apply the Golden Rule, and show the proper consideration for their neighbors.

"All radio receiving sets should be tuned down very low, so that the signals will be confined to a very limited area. Low, soft tones are, in many respects, much more satisfying and desirable than loud, harsh ones.

"In all communities the police have authority to eliminate public nuisances. Many towns, villages and cities have enacted ordinances which are proving very effective, in limiting the operation of sound reproducers or 'loudspeakers.' Broadcast stations might help the situation by suggesting to listeners that they tone down their sets when they use them during late hours."

"MOTORING" A GENERATOR

(283) Mr. J. P. B. Apps, Indianapolis, Indiana.

(Q.) I understand that it is possible to indicate the presence of faults in a car generator by "motoring" it. Please tell me something about this procedure.

(A.) It is not possible to tell everything that may be wrong with a generator by merely giving it a "motoring" test, but you can tell a lot. It really takes modern test equipment to tell with certainty what is wrong with a generator—and, what is equally important, when a generator is really right.

But much can be done by motoring a generator. Briefly, "motoring" consists of running the generator like an electric motor.

To do this, place the car generator in a bench vise. The only equipment needed is a 6 V. storage battery, (for all but 12 V. generators, and there are very few of those these days) some wire, and an ammeter reading up to 10 A.

Connect either side of the battery to the vise, for practically all present day machines. From the other terminal of the battery run a wire to the ammeter and another wire from the ammeter to the generator terminal.

If the generator runs steadily at moderate speed and draws from 4 to 6 A, this test indicates that the generator is probably all right.

To be perfectly sure, it should be placed on a test stand and run until thoroughly hot.

However, the generator may run unevenly with very light current consumption but violent twitching of the ammeter needle. This generally indicates an open-circuited armature. The other possibility is that the brushes are not making good contact with the commutator. This latter condition can be checked by pressing down lightly on the brushes as the generator runs. If that makes the generator run smoothly and causes the ammeter to quit flickering, it will probably be sufficient to turn down the commutator and fit new brushes.

If the armature turns in a jerky manner and the current drawn is heavy (10 A. or more) and uneven it is likely that the armature winding is shorted or grounded.

If the field coil or brush ring is grounded the current pulled will be excessive (10 A. or more) and steady.

Should the armature revolve at high speed and the current be down around 4 or 5 A. for a 6 V. machine there is probably an open circuit in the field coil or the third brush isn't making contact with the commutator.

Running at high speed with the field circuit open indicates that the main brushes are off the neutral point. If the brush ring is movable, this brush setting can be corrected. To do this, loosen the screws that hold the brush ring. Then, with the third brush raised, turn on the current for the motoring test. If the armature starts to run, move the brushes against the direction until the armature stops. Then tighten the lock screws. The setting is correct when, with the third brush raised, the armature tends to revolve in the normal direction of rotation, but does not actually start up of its own accord.

While the information given will prove most helpful for quick trouble shooting, it is highly desirable to verify your findings with regular testing equipment such as growlers, meters, etc.

(The above information has been furnished by courtesy of THE BATTERY MAN.)

I.F. SERVICE OSCILLATOR INDUCTANCE

(244) Mr. H. S. Berlinger, St. Paul, Minn.
(Q.) Referring to RADIO-CRAFT Library Book No. 5, "How to Become a Radio Service Man," there are described on pages 49 and 50, R.F. and I.F. oscillators.

I have built the R.F. oscillator and it works very fine. However, I cannot build the I.F. oscillator as I do not know how to wind the 850 microhenry inductance marked L1 and L2. How many turns, and of what size, and what size tube, does this design call for?

(A.) Coils L1 and L2 may be made by winding 400 T. of No. 30 D.C.C. wire on a tube 2 ins. in dia.; take a tap at the 200th turn for the center connection. Although a bank winding is recommended, a more convenient method of making the coil is to wind 100 turns on the form in one layer, cutting back to the starting wire and winding additional layers successively in the same manner until the 4th layer is completed. (It is recommended that the maximum capacity of tuning condenser C1 be reduced to 500 mmf.)

SOUND EQUIPMENT LEASES

(285) Mr. F. Monaco, Pittsburgh, Pa.

(Q.) According to the article, "Servicing the 'Talkies'," Part I, in the November, 1933, issue of RADIO-CRAFT, it seems that Western Electric sound equipment leases have been annulled. I would like to know whether this condition is true in connection with other equipment such as RCA, DeForest, etc.?

(A.) The author of the article, Mr. Aaron Nadell, advises: "The Western Electric leases were not annulled; but a clause in them which prevented the exhibitor buying parts from anyone except Western Electric was pronounced void.

"RCA and all other manufacturers of whom I have knowledge now and for quite a long while past have been selling their equipment outright with no restrictions of any kind relating to purchase of parts or service."

"BLACK LIGHT"

(286) Mr. Arthur Barkus, Oakland, Calif.
(Q.) I have heard mention of "black light." To what does this term refer?

(A.) The term "black light" refers to ultra-

violet radiation and is ordinarily used in connection with devices which produce a negligible amount of visible radiation as compared to the proportion of ultra-violet radiation. In some instances an opaque window is used to filter out the visible rays and in others the "black light generator" or ultra violet light lamp utilizes a dark glass which filters the visible rays.

These "invisible-light" lamps are used mostly for their value as an illuminant in taking photographs in the dark, and for producing fluorescent effects.

MICROPHONE TRANSFORMER

(287) Roscoe E. Magee, London, Ky.

(Q.) Please give me specifications for winding a transformer to match a double-button microphone (200 ohms per button) into a 200 ohm line.

(A.) The design of transformers of this type is discussed in the article, "How to Make Your Own Transformers and Chokes," Part II, in the January, 1934, issue of RADIO-CRAFT. In the tabulation on page 428, for "50 to 200" substitute 140 turns for the primary in the line of type reading "200 to 200."

"HOW TO BECOME A RADIO SERVICE MAN"

(288) Mr. E. L. McNeill, Elkhart, Kans.

(Q.) I have been reading with a great deal of delight your publication, RADIO-CRAFT Library Book No. 5, "How to Become a Radio Service Man." There was a statement made in the book that called forth this letter and the question: What is the best method of securing the necessary technical training to become an efficient radio Service Man? Inasmuch as the answer to this would depend somewhat upon the individual seeking the training permit me to give you a few facts concerning myself and my program.

At present I am engaged in educational work. My college preparation is a 4-year academic course. My progress in the field has been very satisfactory up to the present, but I am faced with the problem of eliminating my competition by securing additional schooling and an advanced degree. The electrical field has always had an appeal to me, and especially the radio division.

Home study seems to me to be rather of the hit-and-miss type. This is what I have been engaging in as a hobby; it has been enjoyable, but the progress has been slow.

(A.) A good Service Man, in these days, is a good practical engineer and his knowledge does not stop with the mere servicing of radio receivers. If you are in a position to take on residential work, the following outline should be of considerable assistance to you in acquiring sufficient knowledge to place yourself on a firm foundation.

The first thing for you to do is to brush up thoroughly on your Algebra, Geometry, and Trigonometry. A knowledge of Calculus and higher mathematics is essential only for very technical work. You should not study the subject of radio until these mathematical subjects have been fully mastered—it is very distracting to be disturbed by some simple problem when attempting to analyze, for instance, the selectivity of a band-pass unit.

After these subjects have been acquired to your satisfaction, obtain some simple book such as Timbie's "Elementary Electricity," and solve every problem in Ohm's law. The problems in this book are valuable to a proper understanding of vacuum tube circuits. Also, there are other chapters in this book which will be of material assistance to you in familiarizing yourself with direct current problems.

The next step should be to secure a copy of "Alternating Current Machinery," by Dawes, Vol. 2. The first part of this book has numerous problems and an excellent introduction to simple alternating current theory and again it will be well for you to solve each and every problem in the first part of this book before proceeding further.

You should now be ready to start the study of radio proper. Procure a copy of Morecroft's "Elements of Radio Communication." This is an excellent book, written by an authority. It should give you a real insight into radio problems.

Following this, read "Principles of Radio," by Keith Henney. This book is profusely illustrated and contains numerous numerical problems which occur in everyday radio work.

Progress in radio work beyond this point would call for further grounding in mathematics.

CROSLEY 170

SOME of the 10-tube Crosley model 170 receivers have an intermittent trouble, the source of which in some cases is hard to locate unless the fault has been encountered before.

The set will suddenly stop and get very noisy and full of squeals. Snapping a light switch or set switch starts it operating again. This trouble was found to be the 8 mf. condenser across the 25,000 ohm bleed resistance. This condenser is one of a 3 section unit, and all 3 should be replaced (for a permanent job).

CROSLEY 170 AND 168

SEVERAL cases of bad hum in these two models was found to be in the Magnavox speaker. If the cone was pushed further into the field it was noticed that the hum disappeared, so we suspected the hum-bucking or voice coil. Upon checking, these were found to be O.K. Upon further examination it was discovered that the voice coil was *not in the field far enough*, and as it was not possible to change this condition very easily on this model, the speaker was taken apart and about 1/3 of the turns removed from the hum-bucking coil. After assembling, the abnormal hum was gone.

CROSLEY 170

THE tone and volume of this 10-tube model can be improved by connecting a bypass condenser of 2 to 4 mf. across the first A.F. bias resistor. Experience has shown that this also helps cut the background noise in this, and the 7-tube models. The condenser mentioned above helps, but reducing the resistance of the diode load resistor helps more. This raises the sensitivity also. It has been our experience that the fading and blasting is not increased by doing this. Change the load resistor from .5-meg. to .35 or .4-meg., depending on conditions.

CROSLEY "FIVER"

WHEN a Crosley "Fiver" 5-tube model develops a noisy volume control, remove the control and take it apart by spreading the split washer on the shaft. Then wash out the grease thoroughly with carbon tetrachloride and let dry. Finally, give the resistance unit a good coating of graphite with a soft lead pencil. Some of these controls develop a click at the low end of the control. This is due to a poor connection between the two different resistance wires used to give the taper. The best remedy for this is replacement.

CROSLEY 175

THE complaint on several of these models was, "no volume; and distortion"—a trouble which is peculiar to receivers using resistance coupling to a push-pull output stage. Upon examining the set it was noticed that 2 of the type 45 power tubes were red hot. An analyzer test showed a high positive voltage on the 2 red-hot tubes. Coupling condensers were suspected, so the set was put on the bench for examination and more tests. All condensers checked O.K., but voltages were below normal. During these tests the power tubes were changed around accidentally. It was then discovered that the grids which were at a high positive voltage before were now negative, and the ones which were negative before were now positive! Tubes were then suspected. All were tested and showed O.K. However, a new set of power tubes (this set uses 4 type 45s) were put in. This cured the trouble.

My explanation is that there was a small amount of gas in 2 of these tubes, and due to the high resistance in the grid circuit the drop due to grid current drove the grids to a high positive potential.

These tubes performed O.K. in another receiver of more conventional design.

HARRY WEIMAR

RCP • RCP • RCP • RCP • RCP

Speaking of NEW TUBE TESTERS Here's a WOW!

IF you are as smart as we think you are, you'll recognize the NEW "DEPENDABLE" TUBE TESTER No. 304 as the biggest value yet!

It has everything you've ever wanted in a tester for today's and tomorrow's needs. Efficiency — reliability — accuracy — convenience — good looks — and low price.

Tests every present type tube and provides for 50% increase.

Direct English-reading "GOOD-BAD" meter with colored scale, and separate line-voltage meter. Automatic Neon-light short and leakage tests (up to one-million ohms) between any two elements. Diode and individual tests on combination tubes. Simple to operate — only one button. Size: 9" x 12" x 5½". Counter and portable models. Beautifully etched, balanced panel, with semi-flush molded sockets and leatherette case.

A Whale of a Value at Only \$19.95

Write for Data Sheets on all
Radio Testing Equipment

RADIO CITY PRODUCTS CO.

46 WEST BROADWAY, DEPT. RC-9, NEW YORK, N. Y.

RCP • RCP • RCP • RCP • RCP

WEBSTER CHICAGO

50 WATT Class "A" Amplifier

for

Wall or Rack Mounting



Type A-66

Webster 50 watt amplifier for wall or rack mounting. Three stage; push pull 845 output, for microphone and phonograph. Output impedance 500 ohms. Special transformers furnished.

FOR CATALOGUE!

Let us put your name on the Webster mailing list to receive our regular bulletins.

The Webster Company
3330 WEST LAKE ST., CHICAGO, ILL.

The Breakers

ON THE OCEAN FRONT

ATLANTIC CITY, N. J.

Situated directly on the Boardwalk and convenient to all Piers and Amusements

PER DAY per person	\$6.00	With Meals Private Bath
EUROPEAN PLAN	\$3.00	Private Bath

Hot and cold sea water in all baths
Excellent Food—French Cuisine
Garage

EMANUEL E. KATZ, *Man. Director*

A BOOK EVERY RADIO MAN NEEDS!



A Valuable, All-round Radio Book

HERE is one radio book that answers every conceivable question on interference. It contains 76 Pages, 8½ x 11 inches, chock full with wiring diagrams, drawings and photographs showing where interference originates—how it is distributed, and how to eliminate it. This is a wealth of information needed by every radio listener, dealer and Service Man.

Send fifty cents in stamps or check **50c** for this book.

RADIO-CRAFT 99 Hudson St., New York, N.Y.

SEXOLOGY

THE MAGAZINE OF SEX SCIENCE

SEXOLOGY, foremost educational sex magazine, is written in simple language and can be read by every member of the family. It is instructive, enlightening—not a risqué book—contains no offensive matter.

Contains 25 important articles on Sex Science, 68 pages, with attractive two-color cover. Here are a few of the more important articles:

Mother-Sons Complexes—Abortion Racket—Gonorrhea—Birthmarks—Sex Dreams—Multiple Births—Sex Life of Savages—Pregnant Virgins—Delayed Menstruation—Sex Education of the Public—Extra Ovaries in Women—Chaneroid.

Get a copy of SEXOLOGY on any newsstand, or, if your dealer cannot supply you, send 25c cash or stamps for current issue.

SEXOLOGY, 95R Hudson St., New York, N. Y.

BALLAST RESISTORS FOR 2 V. TUBES

S. Ruttenberg*

THE new 2 V. tube sets are rapidly increasing in popularity.

They seem to give much more satisfaction than the old battery sets using the type 99 tubes. One of the reasons that has contributed largely to this happy condition is the fact that manufacturers are using "voltage regulators" instead of rheostats. As will be recalled, the type 99 tube became paralyzed when used with a rheostat. The new tubes are equally critical as to overload—yet, in sets equipped with "voltage regulators," very little trouble has been encountered. A great many of these voltage regulator units are being shipped to mail order houses, which are making a larger number of battery sets.

Ten million homes in this country are unwired—10,000,000 people are prospective customers for battery sets. Neglected for years, but encouraged by the efficient 2 V. tubes, the battery set is again asserting itself. The new 2 V. tubes make it possible to obtain results comparable to A. C. operation.

In designing such tubes, minimum battery drain is important. Filaments as small as .001-in. in dia. must be used. Such filaments are very efficient but also somewhat critical. Operating them above 2.2 V. will result in very poor life—below 1.8 V., poor reception. Therefore, at no time should the filaments be operated above 2.2 V. or below 1.8 V.—2.1 to 1.9 V. is very desirable.

Dry batteries on the other hand, have a voltage of 3.2 V. when new, and below 2.2 V. they drop rapidly. The problem, therefore, is to keep the filaments between 1.8 V. and 2.2 V., with a supply voltage of 2.2 to 3.2 V. The 3 methods of filament control now used are: (1) rheostat; (2) tapped resistor; (3) self-regulating resistor.

The first two are hand-operated and, therefore, objectionable because of the danger of operating tubes above 2.2 V. This is especially true when the emission of one tube drops—for then up goes the rheostat to bring in the signal. The voltage on all the tubes is raised above the danger line. Instead of replacing the defective tube—all the tubes will soon require replacement! An automatic regulator is, therefore, essential.

The ballast-type resistor offers the best automatic regulation for 2 V. tubes. In general, this type of unit consists of an iron-wire filament sealed in a tube filled with hydrogen or nitrogen. The iron filament has a strong "positive temperature coefficient." For example—with only a 10% increase in current through the ballast, the voltage drop across it increases 200%! A ballast designed for 0.5-A. with a 1 V. drop across it, will have a drop of 3 V., at 0.55-A. The voltage drop across an ordinary resistor under the same conditions would be only 1.1 V., at 0.55-A.

There are no moving parts or loose contacts in the ballast resistor, therefore, no chance to introduce noise. If over-loaded, it will usually

*Amperite Corporation.

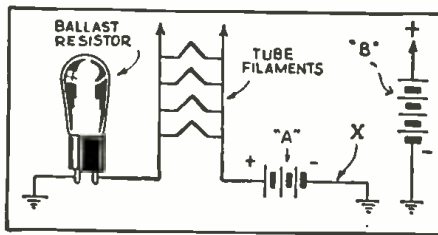
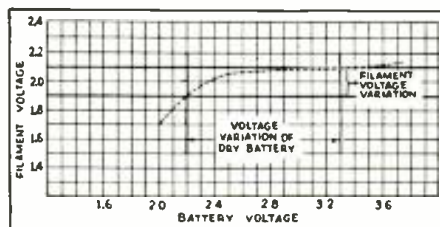

Fig. 1, above. Ballast resistor connection.

Fig. 2, below. Filament voltage control.



last well over 3,000 hours—constantly watching the battery voltage and regulating the filaments accordingly.

One filament ballast can be used for all the tubes in the set. The correct regulator is determined by the total filament current. For a current of 0.4-A., there is available a commercial ballast resistor known as the 4-1; for 0.5-A., the 5-1; and for 0.55-A., the 5H-1 (H meaning "half"). The unit may be used in either the positive or negative lead. It should be connected as shown in Fig. 1, so that an accidental short will not connect the battery directly across the resistor (as would be the case if the ballast resistor was connected at "X").

The same ballast resistor may be used with a 2 V. aircell battery, a 2 V. storage cell, the 2 V. tap of a Delco lighting plant, or 2 dry cells in series. To operate the set on 32 V. (farm lighting power supply), or any other supply, all that is necessary is to change the ballast resistor. Thus, a set equipped with a single regulator socket is immediately adaptable to any supply voltage.

The curve in Fig. 2 shows the control that may be obtained over the voltage applied to the filament of a 2 V. tube when used with dry cells.

HOW TO INSTALL REPLACEMENT TRANSFORMERS

Part II

G. McL. Cole*

IN THE March, 1934, issue of RADIO-CRAFT appeared, in Part I of this 2-part article, a discussion of the design and installation of the "high-voltage" type of "multi-tap" replacement power transformer; the "universal" type, for lower voltage circuit requirements, which was not discussed at length in the preceding data, is described in this, the concluding article.

The First Step

The first step is to determine what types of sets are most likely to be encountered in service. This is another way of saying, what are the most popular set types on the market today—from the service engineer's standpoint?

In Table I is listed set types showing tubes only, arranged according to the filament windings required on the transformer. This list considers only the type of tubes and not the total number of tubes in any particular set.

TABLE I

A—26, 27, 71A, 80	F—24, 27, 71A, 80
B—26, 27, 45, 80	G—24, 27, 45, 80
C—24, 71A, 80	H—24, 45, 82
D—24, 45, 80	J—24, 45, 83
E—24, 50, 80	K—6.3 V. tubes, 80

Where a 24 is designated it is to be understood that this represents any 2.5 V. heater tube, and likewise the 45 as any amplifier tube with the same filament voltage. To the list of set types can be added 6.3 V. tubes with type 82 or 83 rectifiers in place of the 80. Also combinations of 6.3 V. tubes with type 45 amplifiers and 80, 82, or 83 rectifier. Though many more such set types are readily brought to mind, the above list serves to illustrate the following points and so is sufficient.

A transformer wound to take care of type A is of no use for type B or F, nor can type K be used in place of H or E, etc. Obviously then, one transformer is required for every set type for any given number of tubes.

Table II shows the set types classified according to the number of tubes in the set, from 4 to 10 tubes.

TABLE II

No. of Tubes	Types of Trans.	No. of Trans.
4	D-H-K	3
5	A-B-C-D-F-G-H-J-K	9
6	A-to-K, inc.	10
7	A-to-K, inc.	10
8	A-to-K, inc.	10
9	A-to-K, inc.	10
10	A-to-K, inc.	10

*Chief Engineer, General Transformer Corp.

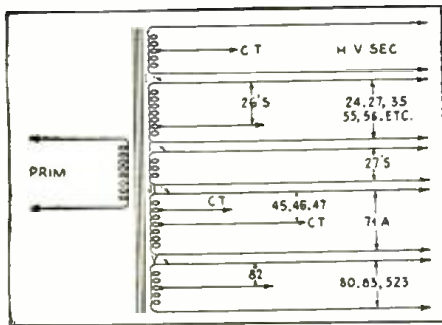

Fig. 1. Connections of the "universal" transformer.

Since, as it was shown in Table I that A, B, C, etc., represent separate and different transformers the numbers to the left, in Table II, are in actuality the number of transformers required to service these sets. Remember, too, that this is only a partial listing. The difference in any two adjacent groups is such that they may be very safely combined, as indicated in Table III.

TABLE III

No. of Tubes	No. of Trans.
4	3
5-6	10
7-8	10
9-10	10

The number of transformers is now reduced to 33. (Look through any of your catalogs—you will find them all there—with several additions!)

The "Universal" Transformer

Figure 1 shows the general schematic of a "universal"-type multi-tap transformer. Naturally, the primary and secondary windings are required for all of the transformers, no matter what the tubes or the set type. Consider the set types Table I, in relation to Fig. 1. Tube types A: 26, 27, 71A, 80 are supplied with filament voltage as follows: the 26s from the 1.5 V. portion of winding I. The 2.5 V. tap on this winding remains dead. The 27 (detector) receives its filament supply from II, the 71A from III and the 80 from IV. Tube types B: the 26, 27, and 80 are taken care of in the same manner as in the A type. The type 45 amplifiers use only one-half of the III winding, 1.25 V. being C. T. Tube type C: uses all of winding I for the 24s, the 71A on III, the 80 on IV. Tube type E: the 7.5 V. for the 50s may be obtained by connecting II and III. This gives 7.5 V. with the C. T. at the 1.25 V. tap on the III winding. Tube types F and G: these represent sets requiring 2 separate filament windings for the heater tubes, with additional windings for the amplifier and rectifier tubes. The 24s are supplied from winding I, the additional 24s or 27s from II, and the amplifiers and rectifier from III and IV, respectively. Tube type K: there are several ways of connecting the windings for the 6.3 V. tubes. The simplest is to connect winding II to the 1.25 V. tap of winding III. The resulting voltage is obtained from the start of winding II and the 5.0 V. end of III. This leaves I free to be used with the type 45 tubes if necessary. Tube types H and J: wherever type 82 tubes are encountered either winding II or one-half of winding IV may be used; the 83 will require the full winding of IV.

The Watts Rating

In this manner it can be shown that this arrangement of transformer winding takes care of not only every set type from A to K but many more combinations. Inasmuch as the transformer satisfied the tube voltage, specifications and current of A and B, also C, D, E, etc., Table III may be modified as in Table IV, in order to accommodate a given number of tubes.

TABLE IV

No. of Tubes	No. of Trans.
4	1
5-6	1
7-8	1
9-10	1

Thus we see that only 4 transformers, universal electrically and mechanically, and varying only in their power output rating in watts, solve the power problem in replacing the power transformers of over 90% of all radio sets on the market.

DO "SUBHARMONICS" EXIST?

UNTIL recently, it was clearly understood when the term "harmonics of an alternating current" was mentioned, that it referred to a sinusoidal current, the frequency of which was a full multiple of the fundamental frequency. Now, since distortion of radio and audio frequency currents is due to the introduction of harmonics, it sometimes happens that a radio station can be heard on a frequency which is a simple fraction of its fundamental. This phenomenon has led to the idea of the existence of so-called "subharmonics." A closer examination discloses, however, that reception of this type occurs quite regularly when the incoming signal is very powerful and when the receiver uses an oscillating tube circuit.

Therefore, this phenomenon only serves to confirm the accepted fact, that there are no subharmonics, because the reception can be explained as being due to heterodyning between the incoming wave and a harmonic of the oscillating tube circuit. A mathematical analysis of the Fourier series shows only the existence of higher frequencies, a fact which is perfectly in accordance with the existing experimental data.

Nevertheless, in the last few years we were forced in various fields of physics to correct many of our well-established conceptions and it seems that the same will be necessary in connection with the much-discussed "notion" of subharmonics.

Independent observations of F. R. W. Stafford and P. O. Pedersen have proved that suboscillations (subharmonics) really exist! (According to RADIO-WELT, No. 1, 1934.)

Stafford discovered, that by sending a pure sinusoidal A.F. current through a dynamic speaker a tone could be clearly heard, the frequency of which was exactly one-half that of the current. In this experiment a paper cone used.

Pedersen gives the following information: "We were able to ascertain that with an output of 5 W. from the A. F. generator, the dynamic reproducer which was used delivered, beside the fundamental and some upper-harmonics, also a lower tone, which had one-half the frequency of the fundamental; in other words, a tone which can be considered as a 'second-subharmonic.' These subharmonics appeared with a definite value of the applied voltage, and their amplitudes seemed to be quite independent of this voltage. The sub-harmonic did not instantly reach its maximum value. When the applied voltage was even slightly above the critical value, then the subharmonic reached its normal amplitude within a few seconds."

The observations of Pedersen and Stafford are in accord. A fourth-subharmonic could be detected in the later experiments. It required, however, a much stronger fundamental than was used when only a second-subharmonic was generated.

Further, it has been observed that there exists a connection between the appearance of the subharmonic frequencies and the irregular variation of the impedance of the loudspeaker. This fact suggests that the resonance of the diaphragm probably plays an important role. As a matter of fact, the subharmonics appear only at certain frequencies of the fundamental.

(Continued on page 189)

Fig. 1. Circuit producing "subharmonics."

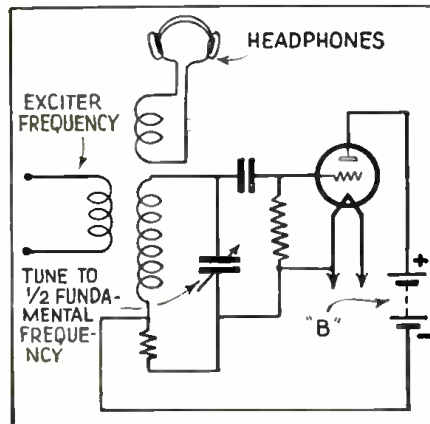

LITTLE DYNAMITE

A POWERFUL high quality amplifier yet extremely compact in size (measuring 3 x 5 x 6" high). Has excellent response over the audio band. Especially suitable for small or portable P.A. Systems for recording and for use in conjunction with photo cells, etc. Uses a 57 high gain pentode and the dual triode 2B6 tube. An 80 tube provides humless plate supply. Overall gain 80.5 db. Will supply 1-1000 ohm field. Output 5 watts. List price, less tubes \$22.50. Dealer's net price



\$8.95

Three Arcturus Tubes net \$3.15.

Just Out

Alan 60A centralized unit will supply up to 20 watts of undistorted output from phono-radio-mike. Has special switching arrangement for switching input source. Input 500 ohms, 200 ohm double button mike, and high impedance. Mike current supply built in. Output impedances 3, 7, 15, 500 ohms. Comes complete in large crystalized cabinet. List price, less tubes, \$90.00, dealer's net

\$42.50

Set of Arcturus tubes containing 2-53s, 2-2B6s, 1-523, \$7.10 net.

Write in for free Alan Sound Handbook off the press soon.

ALAN RADIO CORP.

83-R Cortlandt Street New York, N. Y.

FLECHTHEIM SUPERIOR CONDENSERS

• And Now •
CARBON RESISTORS

These units are cold moulded and heat treated securing absolute stabilization. R. M. A. COLOR CODED—STAMPED "FLECHTHEIM". All values—all ohmages—distinctively packed—attractively priced.

AUTO SUPPRESSORS

FLECHTHEIM presents only three types—Universal-Midket Bracket and Distributor—but they meet every suppressor requirement.

• CONDENSERS •

FLECHTHEIM superior quality appears in every conceivable type of condenser. TRANSMITTING, PAPER, TUBULAR and LICENSED DRY ELECTROLYTICS, inclusive of replacement blocks for all popular sets.

1934-35 CATALOGUE

Completely lists the entire FLECHTHEIM parts replacement line. If your jobber cannot supply you, write direct to

A. M. FLECHTHEIM & CO., Inc.
136 Liberty Street New York City

TRUVOLTS HAVE 1000-VOLT INSULATION

Also patented spiral, air-cooled winding, with adjustable, sliding clips, and full-length protective fibre guard. All standard sizes.

Write for New Catalog "RC-9"

175 Varick St., New York, N. Y.
ELECTRAD

BARGAINS

All Merchandise Offered On Page
Is Absolutely New And Unused

HERE IS A GREAT VALUE!

Electrical Portable Sprayer Outfit

\$27⁵⁰
COMPLETE

Formerly sold for \$68.50

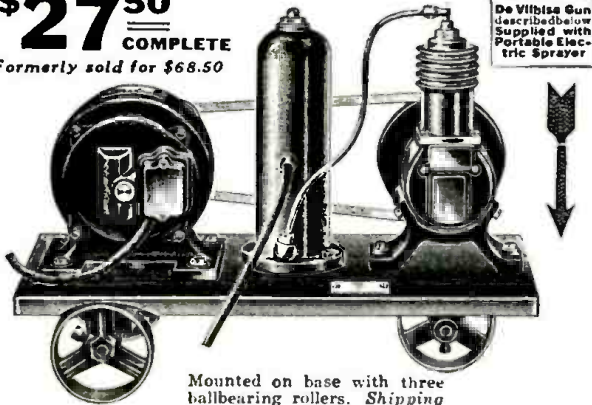

De Vilbiss Gun described below Supplied with Portable Electric Sprayer

Mounted on base with three ballbearing rollers. Shipping weight of complete outfit, 55 lbs.

This is the ideal outfit for all-around spraying work wherever current is available. With this electric sprayer you can spray paint, varnish, duco, enamel, lacquer, insecticides, etc., with speed. You can move it from one room to another with ease. Simply insert plug into electric socket and this marvelous machine is ready to do a man-size job—and do it efficiently.

This electric portable sprayer saves its cost over and over again on your own work. It will make money for you doing jobs for others.

Outfit equipped complete with De Vilbiss Gun, Universal head, with quart aluminum cup, which enables you to obtain round or fan spray. $\frac{1}{2}$ H.P. heavy duty motor, 110-volt, 60-cycle AC, air filter, safety valve, Kellogg Air-Cooled Compressor, $1\frac{1}{2} \times 1\frac{1}{2}$, 15 feet of hose, cord and plug. Pint mason jars can be used on gun for extra containers. Furnished with 50 lbs. pressure tank.

Price of complete outfit with gun, \$27.50
Price of outfit without motor, \$20.00

De Vilbiss Spray Gun

A fast suction-feed attached cup spray gun for use with low pressure compressing units of small displacement. Operates from 20 to 50 lbs. pressure. Produces fan spray 5" in width. Tip adjustable for either round or flat spray. Material flow control, will spray lacquer, enamel, paint, varnish, and duco. Produces smooth, even finish, displacement 2 cu. fl. per minute, equipped with aluminum quart cup. Pint glass mason jar can be used for extra container.

Shipping weight, 3 lbs.

\$5⁹⁵



Big Bargain

Filter Tank \$4²⁵

Complete with tank, gauge and 60 lb. safety valve. Compressed air filter and expansion tank, equipped with gauge and safety valve. Has standard taps in tank and base ready to install. Eliminates oil and moisture. Same as illustrated in Electric Portable Sprayer Outfit shown above.

Shipping weight 8 lbs.

Kellogg Air-Cooled Compressors at less than half price!

Same as illustrated in Electric Portable Sprayer Outfit shown above.

Size	Maximum Pressure	Speed	Motor	Price
$1\frac{1}{4} \times 1\frac{1}{4}$	75 lbs.	600	$\frac{1}{4}$ H.P.	\$7.50
$1\frac{1}{2} \times 2$	100 lbs.	600	$\frac{1}{2}$ H.P.	9.00
2×2	125 lbs.	600	$\frac{1}{3}$ H.P.	10.50
$2\frac{1}{2} \times 2$	175 lbs.	500	$\frac{1}{3}$ H.P.	12.50

Shipping weight, 12, 13, 14, and 18 lbs.

G. E. MOTORS

These Motors were manufactured by the General Electric Company and originally intended for use by a large manufacturing company.

Here are the specifications: 1/30 h.p.—4800 R.P.M. Universal A.C. and D.C. 110 volts instant reverse. Size: Diameter 3 inch, length 5 inch. Shipping weight, 3 lbs. Add 25c for special packing and mailing anywhere in U.S.A.

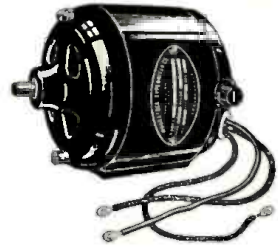

\$2⁴⁵
EACH

WHILE THEY LAST

Original Price \$12.00

HEAVY DUTY Electric Drill $\frac{3}{8}$ in.

\$14⁹⁵

Shipping weight, 7 lbs.

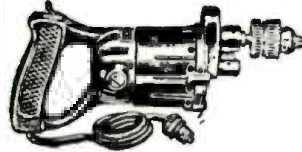

SPECIFICATIONS

WEIGHT—6 pounds. Perfect balance.
CAPACITY— $\frac{3}{8}$ inch.
MOTOR—Westinghouse Universal, specially constructed for this drill. 110 volt, DC, or 60 cycle, AC.
BODY—Aluminum.
R.P.M.—2,000 revolutions per minute. Full load speed, 850 RPM.
GEAR REDUCTION— $\frac{7}{8}$ to 1.
BEARINGS—Special high-grade bronze.
GEARS—Nickel alloy steel and high-grade bronze.
VENTILATION—Forced, around field and armature.
SWITCH—Normally open, quick break. Designed for this drill. Approved by Underwriters.
CHUCK— $\frac{3}{8}$ inch—keyless.
LENGTH—Over all, 12 inches. All parts interchangeable.
EQUIPMENT—Complete with chuck, 7-foot rubber-covered cord and steel-armored, unbreakable attachment plug.

Westinghouse Power Generator

Manufactured by Westinghouse for U. S. Signal Corps.

Built-in commutator takes off the generated D. C. Three leads extend through the casing to permit a $4\frac{1}{2}$ V. flashlight-type battery to be switched into circuit for starting, and to control the A.C. output. Rotated at its normal speed of 4,500 r.p.m., the output is 200 W. at 115 to 125 V. (on open circuit), 900 cycles. The rotor turns in ball bearings. Shaft length (driving end), 2 ins.; diameter $\frac{3}{16}$ -in.; the end is threaded for a diameter of $\frac{3}{8}$ in. Base dimensions exclusive of the shaft, $4\frac{1}{2} \times 4\frac{1}{2}$ in. in diameter. Guaranteed new and perfect.

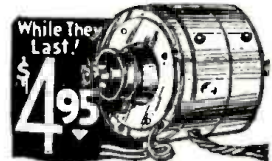

While They Last!
\$4⁹⁵

Shipping weight, 13 lbs.

Here is what one of our customers writes:

"These generators are being used in a small fishing village, where the only current is supplied from a 2K.W. D.C. generator.

"As it was impossible to use A.C. sets and especially my short wave transmitter using two 45 tubes, one of the generators is used to supply my two A.C. receivers and the other to supply power for the transmitter. Both generators are run by a $\frac{1}{4}$ horsepower motor. These generators perform perfectly and have been absolutely trouble free. The voltage and current regulation is remarkably stable, taking a considerable overload."—(Name supplied on request.)

G. E. Phonograph Motor

Variable speed induction type self-starting, 110 volt, 60 cycle, AC, with lever control. Speed range from 5 to 200 RPM. Can be installed in place of old-fashioned, hand-winding speed motor.

Also ideal for display turn table, and a hundred other uses. These G.E. Electric Motors are brand new, in original factory cartons. Same motor that formerly sold for \$15.00, **\$3⁹⁵** only.

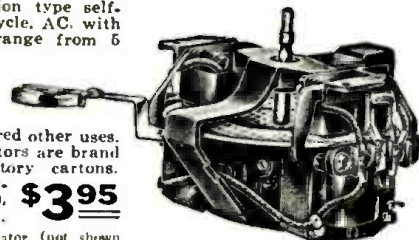

Complete with speed regulator (not shown in above picture).
Shipping weight, 11 lbs.

Formerly Sold for \$15.00

WELLWORTH TRADING CO. RC-9
560 West Washington St., Chicago, Ill.

I enclose \$..... for which please send me the following:

Name.....
Address..... City..... State.....

ORDER FROM THIS PAGE

Since We Do Not Publish Any Catalog

Remit by check or money order for full amount of each item—shipped by express collect, if no money for P.P. enclosed. No C.O.D. order accepted. Money refunded if not satisfied. Be sure to state shipping point if express or freight office is not in your town.

WELLWORTH TRADING CO.
560 West Washington St. Chicago, Ill.

● Index to Advertisers ●

A	
Aerovox Corporation	178
Alan Radio Corporation	187
Allied Radio Corp. 172, 175, 176, 178, 179, 183	
B	
Blan the Radio Man, Inc.	178
The Breakers	186
Bud Speaker Company	174
C	
Capitol Radio Engineering Institute ...	181
Central Radio Laboratories	166
Classified Section	184
Coast-to-Coast Radio Corp.	168
Concourse Electric Co.	174
Coyne Electrical School	129
D	
Tobe Deutschmann Corp.	170
E	
Electrad, Inc.	187
F	
A. M. Flechtheim & Co.	187
Furdson Radio Mfg. Co.	176
Freed Radio Company	174
G	
General Cement Co.	170
General Transformer Corp.	175
Grenpark Company	190
H	
Hammarlund Mfg. Company	172
Harrison Radio Company	174
Hygrade-Sylvania Corp.	171
K	
Kato Engineering Co.	174
Kay Specialty Mfg. Co.	176
L	
L & L Electric Company	166
Arthur H. Lynch, Inc.	172
M	
Midwest Radio Corp.	Back cover
N	
National Radio Institute	131
National Union Radio Corp.	175
P	
Pioneer Sound Labs.	176
Popular Book Corp.	182
Popular Medicine	178
Postal Radio Corp.	174
R	
Radio & Amplifier Labs.	170
Radio City Products Co.	185
Radio Trading Company	192
Radio Training Association	183
Radolek Company	179
Raytheon Production Corp.	167
RCA Institutes, Inc.	176
RCA Victor Co., Inc.	181
Readrite Meter Works	169
Remington Rand, Inc.	184
S	
S. O. S. Corporation	178
Sexology Magazine	186
Shure Brothers Company	172
Solar Mfg. Company	172
Supreme Instruments Corp.	179
T	
Triplet Elec. Instrument Co.	173
Try-Mo Radio Co., Inc.	178
W	
Webster Company	185
Westworth Trading Co.	188
Weston Elec. Instrument Co.	165
Wright-DeCoster, Inc.	177

(While every precaution is taken to insure accuracy, we cannot guarantee against the possibility of an occasional change or omission in the preparation of this index.)

DO "SUBHARMONICS" EXIST?

(Continued from page 187)

After a series of experiments, Pedersen subjected to a mathematical analysis the problem of subharmonics. When an outside sinusoidal oscillation is applied to an oscillatory circuit having a single degree of freedom (an oscillatory circuit with a single resonant frequency), a subharmonic oscillation of one-half the frequency may appear, if the oscillatory system is tuned to this frequency (or very close to it).

A certain amount of feed-back action exists between the receiving system and the generator, and the instantaneous value of this amount depends partially upon the amplitude of the oscillation. Another possibility of producing subharmonic oscillations will exist when the feed-back action of the oscillations instead of being directly proportional to the amplitudes is a function of a second, or higher degree. In both cases secondary conditions have to be satisfied which depend upon the values of the masses, the amount of damping (or inductance and resistance values), and also upon the amplitude of the fundamental.

It follows from the mathematical analysis, that a system with a single degree of freedom (i.e., which has a single resonant frequency), can generate only a second-subharmonic.

Higher harmonics may be formed under certain conditions in a system with two degrees of freedom (for instance, two coupled oscillatory circuits). It is presumed that the second-subharmonic exists here. Now it happens that a loudspeaker diaphragm is a system with several degrees of freedom (several resonance frequencies), and thus in most cases the conditions for a feed-back action are satisfied; therefore, subharmonics do appear here.

An experimental proof of these analytical deductions is given in Fig. 1. The circuit represents a separately-excited oscillator when the grid and plate voltages are so adjusted as to have the tube (a standard triode) operate on the parabolic part of its characteristic. The entire system may then be considered as having a non-linear feed-back action, a condition which, according to the above theory, is necessary for the production of subharmonics. If the other values of the oscillatory circuit meet the theoretical requirements, the circuit is tuned to one-half the exciting frequency, and then supplied with the exciting current. A subharmonic oscillation will be found to exist in the loosely-coupled headphone circuit. This arrangement operates so well, that a change in the exciting frequency will cause a corresponding variation of the subharmonic.

PHILCO 37 BATTERY SET

SEVERAL Philco 37 battery receivers have come in with open antenna coils. This condition can usually be detected by placing a finger on the stator section of the band-pass condenser. An increase in volume will result if the antenna coil is open. The antenna may be clipped to the stator plates of the bandpass section of the condenser gang to affect a temporary remedy unit it can be replaced.

The filament current of the 37 chassis is too high to permit operation from an aircell. We always recommend operating this set from a storage battery, using a fixed resistor—a No. 6 ballast resistor—in series with the "A" lead to reduce the voltage to 3 V. The No. 6 ballast tube will take care of the extra volt. A resistance of 4 ohms is about right. A fully-charged battery should be used to adjust this value.

ECHOPHONE 60

DEFECTIVE filter condensers in the Echophone 60 set can often be detected by the action of the volume control. Erratic operation of this unit has been traced directly to the filter condensers in many cases. They are located directly under the power transformer where they receive considerable heat which appreciably shortens their life.

SILVER-MARSHALL "BEARCAT"

IN MANY cases these sets have developed a healthy hum. In nearly every instance voltage tests showed no screen-grid voltage. Replacing the 10,000 ohm, 5 W. resistor feeding the screen-grids will overcome both conditions. (This resistor is the only 5 W. unit in the set.)

NORMAN G. WISWELL

FREE
48-Page Supplement
to the Auto-Radio
Service Manual!

To everyone who now purchases the OFFICIAL AUTO-RADIO SERVICE MANUAL this big 48-page Supplement is issued FREE. Practically all of the latest sets, together with servicing information will be found in these new pages. The new Supplement does not increase the cost of the book to you, but gives you an Auto-Radio Service Manual that is right up-to-the-minute with service notes.

Good Money in Servicing Auto-Radios

If you are overlooking servicing auto radios, you're missing a great deal of business. The auto-radio business had its greatest boom last summer when thousands of sets were sold. By now many of these same sets require servicing and with hundreds of them right in your own community, you can build up a good auto-radio servicing business. In a short time you can easily add 25% profit or more to your regular servicing business.

List of sets covered in the Manual

- | | |
|-------------------------------|---------------------------------|
| Aerme Radio Mfg. Co. | P. R. Mallory & Co. |
| Allied Radio Corp. | Melborn Radio Mfg. Co. |
| Alwater Kent Mfg. Co. | Montgomery Ward & Co. |
| Autolite Radio Co. | National Co., Inc. |
| Autocrat Radio Company | Noblitt-Sparks Ind. Inc. |
| Automatic Radio Mfg. Co. | Philco Radio & Tel. Corp. |
| Carter Generator Corp. | Pierce-Airo, Inc. |
| Century Radio Prods. Co. | Premier Electric Co. |
| Chevrolet Motor Company | Radio Chassis, Inc. |
| Consolidated Industries, Ltd. | RCA Victor Co., Inc. |
| Crosley Radio Corp. | Sentinel Radio Corp. |
| Deleo Appliance Corp. | Sparks-Whitington Corp. |
| Detroit Radio Corp. | Stewart Radio & Tel. Corp. |
| Emerson Electric Mfg. Co. | Stewart-Warner Corp. |
| Enda Radio & Elec. Corp. | Stromberg-Carlson Tel. Mfg. Co. |
| Federated Purchaser, Inc. | Transformer Corp. of Am. |
| Ford-Majestic | United Amer. Bosch Corp. |
| Franklin Radio Corp. | United Motors Service |
| Galvin Mfg. Corp. | U. S. Radio & Tel. Corp. |
| General Electric Co. | Utah Radio Prods. Co. |
| General Motors Corp. | Wells-Gardner Company |
| A. H. Grebe & Co. | Wholesale Radio Serv. Co. |
| Grigsby-Grunow Co. | Rudolph Wurlitzer Mfg. Co. |
| Chas. Hoodwin Company | Zenith Radio Corp. |
| International Radio Corp. | |

\$2.50

Over 200 Pages
Over 500 Illustrations
9 x 12 Inches
Flexible, Loose-Leaf Cover



MAIL THIS COUPON TODAY!

GERNSBACK PUBLICATIONS, Inc. RC-934
99 Hudson Street, New York, N. Y.

Enclosed you will find my remittance of \$2.50 for which please send me One Copy of the OFFICIAL AUTO-RADIO SERVICE MANUAL with FREE 48-Page Supplement. Send remittance in check or money order. Register letter if it contains cash or currency. WE PAY POSTAGE.

Name

Address

City State

follow the crowd — they're going "Short-Waves"

THE OFFICIAL DOERLE Short-Wave RECEIVERS 15-200 Meters



YES, the crowds are going "wild" over short-waves; and the Doerle receivers are making them even wilder. Many have built their own and have obtained miraculous results. Others have purchased them already built and have obtained even better results. And why shouldn't they? These receivers, fundamentally, are so simple that they are absolutely fool-proof. As a result, they work ANYWHERE—not only in this country—but in any location. Day after day, night after night and with amazing regularity, they pull in stations from the far corners of the earth—REGULARLY—always on the same points of the dial.

Only parts of the highest quality, such as Hammarlund variable condensers, etc., are employed; for we fully appreciate that "a short-wave receiver is no better than the poorest part going into its construction." All fancy gadgets and embellishments have been entirely removed, only the most fundamental parts necessary for successful operation are employed. You will be impressed with their simplicity. You will be even more impressed with their operation. These receivers will convince you that foreign reception CAN be obtained—and with uncanny regularity—whenever they are on the air.

The Doerle receivers are available in two types, each type consisting of two models. The Electrified Doerle, both the 2-tube and 3-tube models were designed for those localities where electric service is available. They must be used in conjunction with a specially-designed hum-free A.C. power pack. The 2-volt battery types were designed for the rural districts. They, too, may be had in 2 and 3-tube models.

It may be possible for you to purchase similar receivers or parts for such receivers at greatly reduced prices elsewhere. We admit this at once. But unless you, too, wish to join the ranks of the disillusioned and skeptical short-wave fans you will insist upon the Official Doerle Receivers—Receivers which contain only highest quality parts. All Doerle receivers are built on beautiful, crackle-finished chassis and bear the official name-plate of the only recognized Doerle manufacturer. All 2-tube models measure 9" x 6" x 6"; 3 tube models 10½" x 7" x 8".

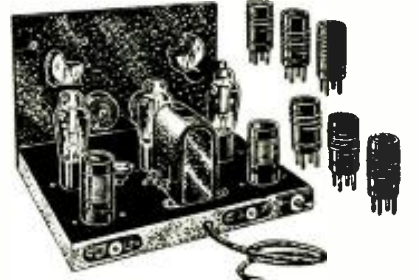

- No. 2140 2-Tube 12,500 Mile Doerle Receiver Completely Wired and Tested. Shipping Weight 5 lbs. **YOUR PRICE \$9.88**
- No. 2142 Complete Accessories. Shipping Weight 23 lbs. **YOUR PRICE \$5.38**
- No. 2143 3-Tube Doerle Signal Gripper Completely Wired and Tested. Shipping Weight 7 lbs. **YOUR PRICE \$12.84**
- No. 2145 Complete Accessories. Shipping Weight 37 lbs. **YOUR PRICE \$7.19**
- No. 2174 Electrified 2-Tube 12,500 Mile Doerle Receiver Completely Wired and Tested. Shipping Weight 5 lbs. **YOUR PRICE \$10.44**
- No. 2176 Complete Set of Tubes for Above: Either 1-57 and 1-58 for A.C. operation or 1-77 and 1-37 for battery operation. **YOUR PRICE \$1.60**
- No. 2177 Electrified 3-Tube Doerle Signal Gripper Completely Wired and Tested. Ship. Wt. 7 lbs. **YOUR PRICE \$15.29**
- No. 2179 Complete Set of Tubes: Either 1-58; 1-57 and 1-56 for A.C. operation or 1-78; 1-77 and 1-37 for battery operation. **YOUR PRICE \$2.50**
- No. 2149 Special Hum-Free A.C. Power Pack including 80 Reformer Tube. **YOUR PRICE \$7.29**

Just Imagine! — 2-TUBES



in one
GLASS BULB

that's the
"TWINPLEX"

15 to 200 Meters

The new type 53 tube makes possible this Twinplex "double-action" receiver. This tube actually contains 2 separate tubes in the same glass envelope. Just imagine what this means! It means that a 2-tube receiver can now be built for the price of a 1-tube set. This is exactly what has been done in the Twinplex receiver. A comparison of tubes with the Doerle 2-tube receivers listed above will immediately substantiate this statement. And what's more, it actually performs like a 2-tube set. The circuit is practically the same as the 2-tube Doerle—extremely simple and therefore entirely fool-proof. You will receive stations which you never knew even existed before. We have received many letters from satisfied users of the Twinplex receiver praising it to the skies. And justly so, for it is a wonderful little set. It affords full band coverage of from 15 to 200 meters which includes the amateur bands, police and airplane calls, foreign reception and numerous code stations.

Only the finest quality parts such as Hammarlund variable condensers, Kurz Kasch high-ratio vernier dials, etc., are employed. All these parts are mounted in a beautiful, crackle-finished metal chassis which entirely does away with "hand capacity."

The receiver is universal in operation which means that it may be operated either with batteries or with an A.C. short-wave power pack. 180 volts is required for the plates of the tubes and 2½ volts, either A.C. or D.C., for the filaments. For a fan who is first starting in the short wave game, the Twinplex is the most economical receiver with which to begin.

No. 2115 Twinplex "Double-Action" Short-Wave Receiver Completely Wired and Tested, including diagram but less tubes. Shipping Weight 9 lbs. **YOUR PRICE \$7.50**

WE ISSUE NO CATALOG

All orders are F. O. B. New York. Terms: A deposit of 20% is required with every order. Balance may be paid on delivery. Deduct 2% if full amount is sent.

The "PYTHON" Short-Wave Super Lowest Priced Converter in the World

12-200 Meters—Works with All AC Receivers

COMPLETE
Nothing Else
To Buy!



For only \$4.95 you can make your present receiver perform in a way comparable only with expensive short-wave sets. And that is no exaggeration! This means that the range, and therefore the usefulness of your present receiver will be more than doubled; since it will now be able to tune from 550 meters way down to the extremely low wavelength of 12 meters. It means that your present receiver will be able to intercept foreign speech and music, television signals, police calls, and amateur pleasantries from all the far corners of the world. Yet without this wonderful little converter is a simple instrument—so simple, that you, or anyone else, without the aid of tools, can easily attach it to any AC receiver in less than five minutes time, and once it is connected it need never again be disconnected, for a convenient toggle switch on its front panel will automatically switch your antenna to either short-wave or broadcast reception. The entire world is going "PYTHON" over short waves. You, too, can fall in line with this simple, yet highly efficient short wave converter—a converter which will prove to you that foreign stations CAN be obtained—REGULARLY—whenever they are on the air. **\$4.95**

A four page pamphlet, including radio log, is furnished FREE with each unit. The price of \$4.95 includes three plug-in coils and tube.

GREN PARK COMPANY

171 Franklin St.

Dept. RC

New York, N. Y.



\$3.50

Reg. List Price

400 Pages
Over 2,000 Illustrations
9 x 12 Inches
Flexible, Looseleaf
Leatherette Cover

There's plenty of Servicing Material in the **NEW 1934 Manual**

THE necessity of GERNSBACK Manuals in the radio field has been shown by the fact that the total sales of the first three OFFICIAL RADIO SERVICE MANUALS, including the new CONSOLIDATED EDITION, now exceed 80,000 copies. Radio Service Men and others engaged in various branches of radio know the importance of such books, and how they must depend upon them for reliable information. Whether for public-address work, tube information or a circuit diagram, the material needed is certain to be found in one of the OFFICIAL RADIO SERVICE MANUALS.

In preparing this new edition many of the outstanding problems of the Service Men have been considered—methods of servicing, the new equipment constantly needed to cope with new tubes and sets, and the other fields of radio, such as public-address systems, short waves, auto radio and others.

The illustrations in the 1934 Manual are more explicit than before; inasmuch as the diagrams are not limited to the schematic circuit, but other illustrations show the parts layout, positions of trimmers, neutralizers, etc. There are hundreds of new circuits included, and not one from any previous editions of the manuals has been repeated. *This we unconditionally guarantee.*

As in previous years, the 1934 Manual also includes a FREE QUESTION AND ANSWER SERVICE. In each book will be found 25 coupons, which entitle you to free consultation on any radio service topic. These coupons give you a complete mail service—questions on servicing and operating any set or circuit are answered promptly and accurately by the editors. Remember that, at the regular rate of 25¢ per question which is usually charged by radio magazines, this service alone is worth \$6.00. And for the Manual, we charge only \$3.50.

It is quite evident that the 1934 Edition of the OFFICIAL RADIO SERVICE MANUAL is a decided improvement over previous volumes.

ORDER YOUR COPIES NOW

It is important to every Radio Service Man and Dealer to get his copy of the 1934 OFFICIAL RADIO SERVICE MANUAL now. The new book will prove itself to be invaluable as those volumes of previous years.

No need to delay sending us your order—the 1934 MANUAL, like its predecessors, is a necessity in your business. We strongly advise you to order your copy today.

GERNSBACK PUBLICATIONS, INC.
99 Hudson Street New York, N. Y.

Contents of the 1934 Manual in Brief

- Diagrams and service notes, more complete than ever before in any MANUAL. Not merely the schematic hook-ups will be found, but chassis drawings showing parts layouts, positions of trimmers, neutralizers, etc.
- Voltage readings for practically all sets, as an aid in checking tubes and wiring.
- All values of intermediate-frequency transformers used in superheterodynes, with the manufacturers' own suggestions as to correct balancing.
- Detailed trouble-shooting suggestions and procedure as outlined by the manufacturers' own engineers—in other words, authentic "dope" right from headquarters.
- Values of all parts indicated directly on all diagrams.
- Section for reference to A.C.-D.C. cigarbox midsets.
- Section for reference to public-address amplifiers.
- Section for reference to short-wave receivers.
- Section for reference to remote-control systems.
- A complete compilation of radio tube data, covering both the old and the many new types.
- Section devoted to test equipment, analyzers, etc., with full diagrams and other valuable information.
- A complete list of American broadcast stations with their frequencies in kilocycles; extremely useful in calibrating and checking test oscillators and in calibrating receivers.
- Free Question and Answer Service, the same as in our last two Manuals.
- No theory; only service information in quickly accessible form.
- Absolutely no duplication of any diagrams; nothing that appeared in any of the previous Manuals will appear in the 1934 MANUAL. This we unconditionally guarantee.
- A handy, easily-consulted master index making it easy for you to find almost anything pertaining to your service problem instantly. This index includes all the diagrams published in all the previous GERNSBACK Manuals, as well as the 1934 diagrams. A big convenience and time saver!

Clip — Mail This Coupon Today

GERNSBACK PUBLICATIONS, Inc.
99 Hudson Street, New York, N. Y.

Gentlemen: Enclosed you will find my remittance of \$3.50 for which you are to send me, Postage Prepaid, One Copy of the 1934 OFFICIAL RADIO SERVICE MANUAL. [Send remittance by check or money order; or register letter if it contains cash, currency or unused U. S. Postage stamps.]

Name

Address

City State

RC-934

RTC's Big September Specials

YOUR DOLLAR — IS WORTH MORE When You Buy From Us

Is the dollar inflated? These days everybody is speaking of inflation but why worry about it, whether the dollar is inflated or not it is worth more when you buy from us. The prices shown on this page are so radically low that no one can possibly undersell them. Our consistent advertisements present to you each month, on this page, certain STAR (*) items which are not listed in our regular catalog. These are all specials of which the small quantity on hand does not permit us to catalog them. **ONCE SOLD OUT NO MORE CAN BE HAD AT ANY PRICE. ORDER TODAY—NOW.** Order direct from this page and save money. 100% satisfaction guaranteed on every transaction.

We are a wholesale house and cannot accept orders for less than \$3.00. If C.O.D. shipment is desired, please remit 20% of the total amount of your order. Balance will go forward C.O.D.

If full cash accompanies your order deduct 2% discount. Send money order, certified check or U. S. stamps.

Be sure to include sufficient extra remittance if order is to be shipped via parcel-post; any excess will be refunded.



FREE

RADIO and Short-Wave TREATISE

108 Pages
1500 Illus.

Completely revised and enlarged, this new 1934 edition contains 108 solid pages of useful radio information, diagrams, illustrations, radio kinks and real live radio merchandise. It contains more valuable radio information—more real live "meat"—than many text books on the subject. **PARTIAL LIST OF CONTENTS:** Fundamental Principles of Radio for the Beginner, Chapter 2—Fundamental Circuits and Uses of New Tubes—Resamping Six Volt Battery Sets for Two Volt Tubes—Public Address Systems—How to Build Short Wave Transmitters and Receivers—Up to Date Tube Chart and Socket Connections, etc., etc. **WRITE TODAY—**Enclose five cents (coin) for postage. Treatise sent by return mail. Print name and address clearly on request.

BIG 8-TUBE SET BARGAIN

★ Complete with 11" Dynamic Speaker
Limited Supply

only \$13⁹²



Not a Midget!
but a full-sized CONSOLE CHASSIS

"THE GREATEST SET BUY IN AMERICA" is by all means a mild description of the value which we are offering here. This very same 8-tube receiver as recent as eight months ago, sold for more than \$95.00, yet now because of the advent of even later type tubes, you can purchase this receiver for only a small fraction of that price. The tubes employed in this set are still comparatively new; and not only that but all modern features such as, 2A5 push-pull output, tone control, phonograph attachment provisions, full dynamic speaker, etc., are incorporated.

The selectivity and sensitivity of this 8-tube receiver, due to its 4 tuned stages, are just as sharp as those of an 11-tube superheterodyne. The construction of the set is best described as "standard," for its circuit is none other than the "good old stand-by" T.R.F. type modified and improved to use these later type tubes. It incorporates 3 stages of tuned R.F. amplification, using type 33 triode grid tubes; followed by a 50 detector. From there the signal is amplified by a type 50 first audio tube, and from there still further amplified by the powerful push-pull 2A5 power output tubes. By the time the signal comes out of these tubes, it is strong enough to operate 4 to 5 dynamic speakers very easily, and many times that number magnetic speakers. A type 80 full-wave rectifier is employed. All provisions for supplying field power to the 11" genuine Oxford dynamic speaker, is incorporated.

Tuning is extremely simple and very sharp, being comparable to the tuning of a superheterodyne receiver. A new type traveling "ghost light" is employed. The three controls on the front of the chassis consist of tuning knob, tone control knob and volume control respectively. The chassis itself is made of heavy steel, beautifully black enameled. All tuned circuits are thoroughly shielded including the tubes and condensers. This prevents feedback, whistling and howling. The use of 4 tuned circuits employing the new triode grid, screen grid tubes and high gain R.F. transformers, together with careful wiring

and by-passing, results in extremely high sensitivity. Many of our satisfied customers inform us that a good variety of distant stations come in regularly like locals. And why shouldn't they, for 4 tuned stages is more than what even more recent sets are employing and everyone knows that the more tuned stages you have the greater is the sensitivity and particularly the selectivity of a receiver. Tone quality, too, is extremely fine and can be controlled to suit the individual, from very high treble down to deep bass.

Why build a set when a complete receiver, fully wired and ready to use and complete with speaker and all modern features, can be bought at such a phenomenally low price. Here, also, is an opportunity for wide-awake servicemen to "clean up." There are little more than 150 of these excellent chassis available, hence "first come, first served." Judging by the rabidity with which our "freebies" receivers sold a few months back, when we had a sale on them, the supply of these considerably superior receivers will not hold out very long. The moral is, "don't delay, order today." Overall size of chassis, 15 1/2" x 11" 8 1/2". Shipping weight, 40 lbs.

List Price \$95.00
No. 2000—8-Tube T.R.F. Receiver Including Dynamic Speaker But Less Tubes \$13⁹²
YOUR PRICE



WORLD-WIDE RECEPTION WITH THE FAMOUS TWINPLEX Short-Wave Receiver

2-Sets in-1

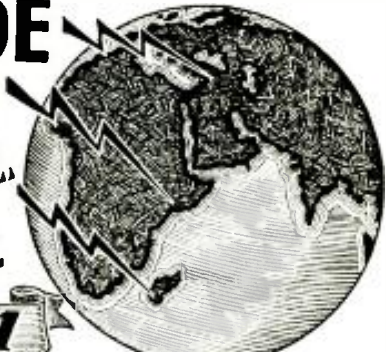

Economical 2-Volt Operation
Complete with Headphone

ONLY \$4.91

SHORT waves are the talk of the hour. The whole country, nay, the whole world, has gone crazy to receive foreign stations, as far as 12,500 miles distant. Usually, such reception is had only with expensive multi-tube sets.

Only recently, the invention of the "19" tube has made it possible to perform the function of two tubes in a single tube. Then came the invention of the TWINPLEX, a radio circuit of unheard of sensitivity, using the "19" tube; it is now possible with a single tube of this type to receive short wave stations from all over the world, loudly and clearly—REGULARLY, night after night, day after day, always in the same place on the dial.

Every radio man knows that in a short-wave set it is highly important to have the wiring as short as possible. By inventing a radically new design, that is by mounting tube and coils, in fact, everything, on the front panel, it has become possible to shorten all connecting wires, with the result that an UNHEARD OF SIGNAL SENSITIVITY has now been achieved for the first time, in a single-tube set.

But the TWINPLEX is ACTUALLY A TWO-TUBE SET; yes, we repeat, A FULL-FLEDGED TWO-TUBE SET AT THE PRICE OF A ONE-TUBE SET.

JUST IMAGINE, TWO TUBES IN ONE GLASS ENVELOPE. That is the story of the new "19" tube. It is a 2-volt tube, which has a DOUBLE SET OF ELEMENTS.

This set has been so designed that it will receive ordinary broadcast stations too—stations which come in with great volume, particularly local stations. These come in

so loud that if you have a loudspeaker, this little one-tube set will ACTUALLY GIVE YOU LOUDSPEAKER RECEPTION.

With this set, we furnish regularly, two coils, one a short-wave plug-in coil, which receives all the popular stations in the 33 to 65 meter band, and a broadcast coil which receives nearly all broadcast stations.

A simplified instruction sheet with detailed instructions and pictorial diagrams shows you how to build the set in a few hours' time, and once you have completed the set, FROM THEN ON, YOU DON'T SLEEP ANY MORE.

The "19" TWINPLEX is available ONLY in kit form and comprises all parts to properly build the receiver in from 1 to 2 hours. ANYONE CAN DO IT. Shipping weight 5 pounds.

No. SW-308 Famous Twinplex Short-Wave Receiver Kit with all parts INCLUDING SINGLE HEADPHONE AND BAND BUT No Tube \$4⁹¹
YOUR PRICE

No. SW-309 Complete Accessories For TWINPLEX Receiver, Comprising 1—Type 19 Tube, 2—No. 6 Dry Cells, 2—45 volt "B" Batteries, Shipping weight 20 pounds. \$3⁵²
YOUR PRICE

Additional Plug-in Coils for the 20, 80 and 160 meter bands—45c each

RADIO TRADING COMPANY, 97 Hudson Street, New York City

ANNOUNCING

A GOLDEN OPPORTUNITY FOR ALERT RADIO MEN IN THE NEXT GREAT INDUSTRY

THE idea of electricians, radio service men and other mechanically inclined men, servicing Air Conditioning and Refrigeration Units is self-evident and the thought has occurred to some untold thousands ever since air conditioning equipment has been installed in public auditoriums, theatres, studios, department stores, office buildings and manufacturing plants. The tremendously broad possibilities in this new industry are bound to give employment and success to men far-sighted enough to see its advancement and development. We quote an excerpt from Mr. Hugo Gernsback's editorial which appeared in a recent issue of *Everyday Science and Mechanics*:

"I advise young and progressive men to go into the air-conditioning business during the next few years; because, this, without a doubt, is the coming industry in this country. Thousands of small firms will spring up, undertaking to air-condition private houses, small business offices, factories, etc. We are not going to tear down every building in the United States immediately. It will be a gradual growth; yet small installation firms will air-condition small houses, and even single offices in small buildings."

This is only partial proof of the certain success of this new field. Further assurance is that engineering schools have already added many important courses on air conditioning to their regular curriculum. Architects and building contractors are giving considerable thought to installation of this equipment in structures which are now being planned and built. The beginning of this business will probably be similar to the auto and radio industry, but in a few short years it will surpass these two great fields.

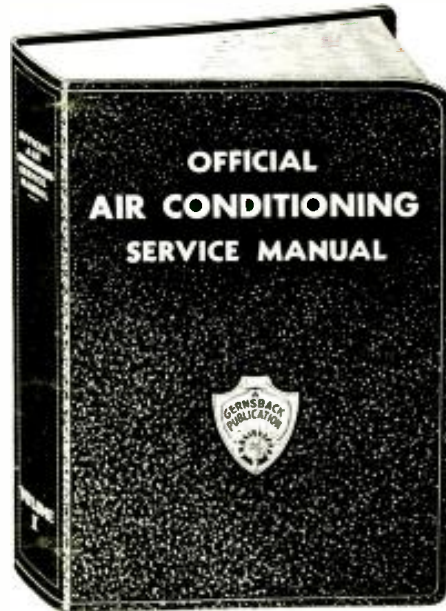

PRE-PUBLICATION OFFER

\$4.00

Official Air Conditioning Service Manual

The OFFICIAL AIR CONDITIONING SERVICE MANUAL is being edited by I. K. Wright, who is an expert and a leading authority on air conditioning and refrigeration. He is a member of the American Society of Refrigerating Engineers, American Society of Mechanical Engineers, National Association of Practical Refrigerating Engineers; also author of the OFFICIAL REFRIGERATION SERVICE MANUAL and other volumes.

In this Air Conditioning Service Manual nearly every page will be illustrated; every modern installation and individual part carefully explained; diagrams furnished of all known equipments; special care given to the servicing and installation end. The tools needed will be illustrated and explained; there will be plenty of charts and page after page of service data.

Remember there is a big opportunity in this new field and plenty of money to be made in the servicing end. There are thousands of firms selling installations and parts every day and this equipment must be cared for frequently. Eventually air conditioning systems will be as common as radios and refrigerators in homes, offices and industrial plants. Why not start now—increase your earnings with a full- or spare-time service business.

You have the opportunity to get your copy of the OFFICIAL AIR CONDITIONING SERVICE MANUAL today—at a saving of ONE DOLLAR. When the book comes off press, which will be September 10th, the price will be \$5.00 a copy. YOUR ORDER TODAY BRINGS YOU A COPY FOR \$4.00. POSTAGE PREPAID. This is our usual courtesy, pre-publication offer which enables us to determine the approximate print order for the first press run. Send us the coupon today, together with a deposit of \$2.00. When the book reaches you, you pay the other \$2.00.

Here are some of the chapter heads of the AIR CONDITIONING SERVICE MANUAL:

Contents in Brief

History of Air Conditioning; Fundamental Laws; Methods of Refrigeration; Ejector System of Refrigeration; Compression System of Refrigeration; Refrigerants; Lubricating Oils; Liquid Throttle Devices; Servicing Expansion and Float Valves; Servicing Refrigerating Systems; Control Devices; Thermodynamics of Air Conditioning; Weather in the United States; The Field of Air Conditioning; Insulating Materials; Heat Transmission Through Walls; Complete Air Conditioning Systems; Estimating Requirements for the Home, Small Store, Restaurant; Layout of Duct Systems; Starting Up a System; Operating and Servicing Air Conditioning Systems; Air Filtration, Ventilating and Noise Eliminating Devices; Portable Electric Humidifiers and Room Coolers; Automatic Humidifiers; Air Conditioning Units for Radiator Systems and Warm Air Systems; Central Conditioning Units, etc.

GERNSBACK PUBLICATIONS, INC.
99 Hudson Street, New York, N. Y.

352 Pages
Over 600 Illustrations
9" x 12" in Size
Flexible, Loose Leaf
Leatherette Cover



MAIL COUPON TODAY!

GERNSBACK PUBLICATIONS Dept. RC-934
99 Hudson Street, New York, N. Y.

Gentlemen: Enclosed you will find my remittance of Two Dollars for which you are to send me One Copy of the OFFICIAL AIR CONDITIONING SERVICE MANUAL, postage prepaid, as soon as it comes off the press. I am to pay the additional Two Dollars to postman when it is delivered. It is understood that the regular price of the book will be FIVE DOLLARS when it comes off the press, and I am now paying only a pre-publication price of Four Dollars.

Name

Address

City State

(Send remittance in form of check, money order or unused U.S. Postage Stamps. Register letter if it contains stamps or currency.)

THOUSANDS ARE *Enthusiasing* OVER THE *New* 1935 MIDWEST-16



Midwest Amazes Friends!
Last night I listened to LSX talk to KFZ and also New York. Then I received KFZ direct. Then I tuned back to LSX and KFZ and heard them plainly. My friends were amazed. Dr. F. G. Naccelli, Devils Lake, N. D.



Marvelous Foreign Reception!
My friends can hardly believe I paid so little for my Midwest 16. My best foreign stations are LSX, Buenos Aires, EAQ, Madrid, DJA, Germany, CWB, England, PIAC, Brazil, G. E. Wagner, 2102 Wyoming Street, St. Louis, Mo.



Unequaled Foreign Reception!
My Midwest brings in thrilling programs from England, Germany, Australia, Venezuela, Columbia, Argentina and principal world stations. My friends marvel at its tone, sensitivity, power and selectivity. La Rue Thompson, Box 554, Johnstown, Pa.



Byrd Expedition Direct!
My Midwest 16 is best radio I have ever seen. It pulls stations I could never get before. Foreign reception clear as locals. Secured Spain, South America, England, Cuba, etc. Also get Byrd Expedition direct. J. H. Hodson, Louisa, Penn.

Thrill to Unequaled World-Wide Performance with this.

Amazing NEW 1935 SUPER Deluxe 16-Tube ALL-WAVE Radio

9 TO 2,400 METERS (12,000 MILE TUNING RANGE)

30 DAYS FREE TRIAL



Guaranteed WORLD-WIDE RECEPTION!

BEFORE you buy any radio, write for FREE copy of the new 1935 Midwest "Fifteenth Anniversary" catalog. See for yourself the many reasons why over 110,000 satisfied customers have bought their radios direct from Midwest Laboratories . . . and saved from $\frac{1}{4}$ to $\frac{1}{2}$. Learn why Midwest radios out-perform sets costing up to \$200 and more. You, too, can make a positive saving of from 30% to 50% by buying this more economical way. Why be content with ordinary so-called "All-Wave", "Dual Wave", "Skip Wave" or "Tri-Wave" receivers when Midwest gives you more wave lengths in today's most perfectly developed 16-tube Super de luxe ALL-WAVE radio that are proven by four years of success . . . that carry an iron-clad guarantee of foreign reception! These bigger, better, more powerful, clearer-toned, super selective radios have FIVE distinct wave bands; ultra short, short, medium, broadcast, and long. Their greater all-wave tuning of 9 to 2400 meters (33 megacycles to 125 KC) enables you to tune in stations 12,000 miles away with clear loud speaker reception. Write TODAY for new FREE catalog!

Now, you can enjoy super American, Canadian, police, amateur, commercial, airplane and ship broadcasts . . . and derive new delight and new excitement from unequalled world-wide performance. Now, you can enjoy the DX-ing hobby and secure verifications from more of

the world's most distant stations. Thrill to the chimes of Big Ben from GSB, London, England . . . tune in on the "Marseillaise" from FYA, Pointoise, France . . . hear sparkling music from EAQ, Madrid, Spain . . . delight in lively tangos from YVBC, Caracas, Venezuela . . . listen to the call of the Kookaburra bird, from VK2ME, Sydney, Australia, etc. Send today for money-saving facts,

TERMS AS LOW AS \$5 DOWN

WORLD'S GREATEST RADIO VALUE

\$57⁵⁰ with New Deluxe Auditorium-Type SPEAKER
... LESS TUBES ...



NEW STYLE CONSOLES
The new, big, Midwest 30-page 1935 catalog pictures a complete line of beautiful, artistic de luxe consoles and chassis . . . in four colors . . . a model for every purse. Hand made by master craftsmen, they harmonize beautifully with any furniture arrangement. Write for new FREE catalog today!

50 ADVANCED 1935 FEATURES

Here are a few of Midwest's superior features: Controllable Expansion of Volume-Selectivity-Sensitivity (Micro-Tenuator) . . . Fidel-A-Trol . . . Triple Calibration Plus . . . Pure Silver Wire . . . Ceramic Coil Forms . . . Separate Audio Generator . . . Simplified Tuning Guide Lights . . . Compact Synchronized Band Switch . . . Amplified Automatic Volume Control . . . 7 KC Selectivity . . . Power Driver Stage . . . 16 Latest Type Tubes . . . etc. Read about these and 38 other features in the new FREE Midwest catalog. Never before so much radio for so little money. Write for FREE catalog.

DEAL DIRECT WITH LABORATORIES

Increasing costs are sure to result in higher radio prices soon. Buy before the big advance . . . NOW! . . . while you can take advantage of Midwest's sensational values . . . No middlemen's profits to pay. You can order your radio from the new Midwest catalog with as much certainty of satisfaction as if you were to select it in our great radio laboratories. You save 30% to 50% when you buy direct this popular way . . . you get 30 days FREE trial . . . as little as \$5.00 down puts a Midwest radio in your home. Satisfaction guaranteed or money back. Write for FREE catalog.

Sign and mail coupon . . . or, send name and address on postal card . . . NOW!

SAVE UP TO 50%

We will send you copies of letters like those shown at top of page. They'll convince you that Midwest radios are sensational values! Try the Midwest for thirty days before you decide. Midwest gives you triple protection with: A one-year guarantee, foreign reception guarantee, money-back guarantee.

MAIL COUPON TODAY! FOR AMAZING 30-DAY FREE TRIAL OFFER AND NEW 1935 CATALOG

MIDWEST RADIO CORP., Dept. 573, Cincinnati, Ohio.

Without obligation on my part send me your new FREE 1935 catalog, and complete details of your liberal 30-day FREE trial offer. This is NOT an order.

Name _____
Address _____
Town _____ State _____

User-Agents: Make Easy Extra Money. Check Here for Details

MIDWEST RADIO CORP.
DEPT. 573 - CINCINNATI, OHIO, U. S. A.
Established 1920 Cable Address Miraco. . . . All Codes