

RADIO'S GREATEST MAGAZINE

# RADIO-CRAFT

Incorporating

**RADIO &  
TELEVISION**



**MANY ARTICLES  
FOR THE  
RADIO  
BEGINNER**



See Page 72

NOVEMBER

**25¢**

CANADA 30¢

1942

**OVER 100 ILLUSTRATIONS**





J. E. SMITH, President,  
NATIONAL RADIO INSTITUTE  
Established 27 Years

He has directed the training of more men for the Radio Industry than any other man in America.



**BROADCASTING** and other types of Radio Stations employ Radio Technicians and Operators with average pay among the country's highest paid industries.



**RADIO REPAIRING**, a booming business right now, with no new sets being made, pays many \$30, \$40, \$50 a week for full time—others \$5, \$10 extra a week for spare time work.



**RADIO OPERATORS** find good jobs with Government Departments, Shipping Companies and in Commercial Aviation; opportunities are increasing in these fields.

### I Trained These Men



Chief Operator Broadcasting Station  
"Before, I completed your lessons, I obtained my Radio Broadcast Operator's license and immediately joined Station WJMP where I am now Chief Operator."  
HOLLIS F. HAYES, 327 Madison St., Lapeer, Mich.



Lieutenant in Signal Corps  
"I cannot divulge any information as to my type of work but I can say that N.R.I. training is certainly coming in mighty handy these days." (Name and address omitted for military reasons.)



\$10 a Week in Spare Time  
"I repaired some Radio sets when I was on my tenth lesson. I really don't see how you can give so much for such a small amount of money. I made \$800 in a year and a half, and I have made an average of \$10 a week just spare time."  
JOHN JERRY, 1337 Kalamath St., Denver, Colorado.

# I will send you a Lesson Free to show how I train you at home in spare time for Good Jobs in Radio

Mail the Coupon for a FREE lesson from my Radio Course. It shows you how N.R.I. trains you for Radio at home in spare time. And with this sample lesson I'll send my 64-page illustrated book, RICH REWARDS IN RADIO. It describes the many fascinating jobs Radio offers, explains how N.R.I. teaches you with interesting, illustrated lessons and SIX BIG KITS OF RADIO PARTS!

**Act Now! Many Radio Technicians Make \$30, \$40, \$50 a Week**

Right now, in nearly every neighborhood, there's room for a spare and full time Radio Technician. Many Radio Technicians are stepping into good spare time and full time Radio Jobs, or are starting their own shops, and are making \$30, \$40, \$50 a week!

Others take good-pay jobs with Broadcasting Stations. Hundreds more are needed for Government jobs as Civilian Radio Operators, Technicians. Radio Manufacturers, rushing to fill Government orders, need trained men. Aviation, Police, Commercial Radio and Loudspeaker Systems are live, growing fields. And think of the NEW jobs Television and other Radio developments will

open after the war! I give you the Radio knowledge required for these fields.

**How My "50-50 Method" Helps Many Make \$5, \$10 a Week EXTRA While Learning**

Many N.R.I. Students make \$5, \$10 a week extra money fixing Radios in spare time while learning. I send EXTRA MONEY JOB SHEETS that tell how to do it!

My "50-50 Method"—half building and testing Radio Circuits with the six kits of Radio parts I send, half learning from illustrated lessons—makes you "old friends" with Radio before you know it. You run your own Spare Time Shop, get practice fixing Radios, get paid while training!

**Find Out What N.R.I. Can Do For You**

MAIL THE COUPON for FREE sample lesson and my 64-page book. You'll discover things you never knew about Broadcasting, Radio Servicing, Manufacturing, other interesting profitable Radio fields. You'll read a complete description of my Course—"50-50 Method"—SIX KITS OF RADIO PARTS—Extra Money Job Sheets. You'll see the many fascinating jobs Radio offers and how you can get started. You'll read letters from many men I trained. Mail Coupon AT ONCE!

J. E. SMITH, President, Dept. 2MX, National Radio Institute, Washington, D. C.

### TRAINING MEN FOR VITAL RADIO JOBS



Men likely to go into military service, soldiers, sailors, marines, should mail the Coupon Now! Learning Radio helps men get extra rank, extra prestige, more interesting duties, much higher pay. Hundreds now in service are N.R.I. students. Also prepares for good Radio jobs after service ends.

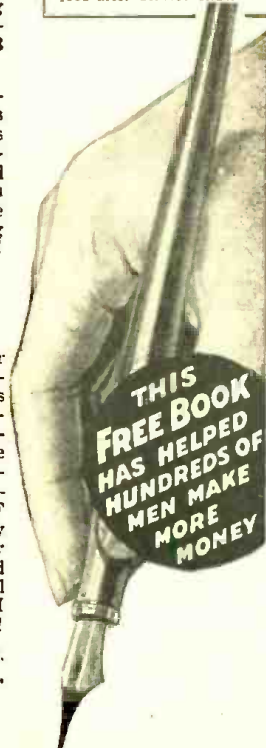

## Good for Both 64 PAGE BOOK SAMPLE LESSON Free

J. E. SMITH, President, National Radio Institute, Dept. 2MX, Washington, D. C.

Without obligating me, mail your Sample Lesson and 64-page Book FREE. I am particularly interested in the branch of Radio checked below. (No salesman will call. Write plainly.)

- Radio Service Business of My Own
- Service Technician for Radio Stores
- Spare Time Radio Servicing
- Auto Radio Technician
- Aviation Radio
- Operating Broadcasting Stations
- Army, Navy Radio
- Operating Police Radio Stations
- Operating Ship and Harbor Radio

(If you have not decided which branch you prefer—mail coupon for facts to help you decide.)

Name ..... Age .....

Address .....

City ..... State ..... 4FB-2



# RADIO-CRAFT

Incorporating

**RADIO & TELEVISION**

**HUGO GERNSBACK**  
Editor-in-Chief

**KARL E. SCHUBEL**  
Associate Editor

**G. ALIQUO**  
Circulation Manager



## Contents NOVEMBER, 1942 Issue

VOLUME XIV -- NUMBER 2

Mailbag .....	68
Editorial: The Radio Beginner is Back..... by Hugo Gernsback	71
The Radio Month in Review.....	72

### SERVICING

Analysis and Alteration of an Analyzer—Part II... by Ted Powell	74
Transformerless Power Supplies—Part II.....	76
<b>RADIO SERVICE DATA SHEET:</b>	
No. 327 Philco Model 42-1010.....	78
Making Analyzer Adapters..... by Dick Booth	81

### TEST INSTRUMENTS

A Simple and Effective Condenser Tester... by Eugene Bertin, Jr.	82
Oscillator Circuit Tester..... by Harry L. Poling	84

### WARTIME RADIO

New RCA Laboratories Dedicated.....	89
Radio Men—Enlist NOW!.....	90
How Ship Receivers Give Away Their Positions by E. H. Scott	92

### SOUND

Plant Broadcasting.....	94
Radio Aids Weather Data.....	96
Burglar Now Calls Police.....	96

### FM

Trouble Shooting in FM Receivers..... by Willard Moody	98
--	----

### ENGINEERING

Pulse Generators and Their Future..... by Werner Muller	100
---	-----

### DEPARTMENTS, ETC.

Mailbag .....	68
The Radio Month in Review.....	72
Servicing Notes.....	77
<b>RADIO SERVICE DATA SHEET (See Servicing)</b> .....	78
Latest Radio Apparatus.....	102
Book Reviews.....	127

## RADIO & TELEVISION

Getting Started in Radio—Part II..... by C. W. Palmer	104
Constructing a Practical Short-wave Antenna by Audie Roberson	105
Tuning Up Your Radio for Fall..... by T. R. Kennedy, Jr.	106
Beginner's One-Tube Receiver..... by Karl E. Schubel	108
An R. F. Pre-Amplifier for Beginners..... by Bob White	110
How to Construct a Tube Checker..... by E. Pottruff	111
Locating Short Circuits..... by Willard Moody	112
A Signal Modifier for Receiving Code Clearly by James Solms	113
R. F. Chokes as Inductance Coils..... by William J. Vette	115
Radio Kinks.....	116
Radio Hook-ups.....	118
A Colpitts-Type Code Practice Oscillator by Henry T. Brummett	122
Phono Amplifier Made With Used Parts... by Richard Holbrook	123
Radio Patents.....	126



Published by Radcraft Publications, Inc. Publication office: 29 Worthington Street, Springfield, Mass. Editorial and Advertising Offices: 25 West Broadway, New York City. Chicago Advertising Office: RADIO-CRAFT, 520 North Michigan Avenue, Chicago, Ill.

RADIO-CRAFT is published monthly, on the first of the month preceding that of date; subscription price is \$2.50 per year in U. S. (In foreign countries, 75c additional per year to cover postage; Canada, 50c additional.) Entered at the post office at Springfield as second-class matter under the act of March 3, 1879. All communications about subscriptions should be addressed to: 29 Worthington Street, Springfield, Mass., or Director of Circulation, 25 West Broadway, New York, N. Y.



#### Foreign Agents:

London—Goringe's American News Agency, 9A Green St., Leicester Square, W. C. 2, England.  
Paris—Messageries Dawson, 4 Rue Faubourg, Boissonniere, France.  
Melbourne—McGill's Agency, 179 Elizabeth St., Australia.  
Dunedin—James Johnston, Ltd., New Zealand.



Text and illustrations of this magazine are copyright and must not be reproduced without permission of the copyright owners.



Copyright 1942 Radcraft Publications, Inc.

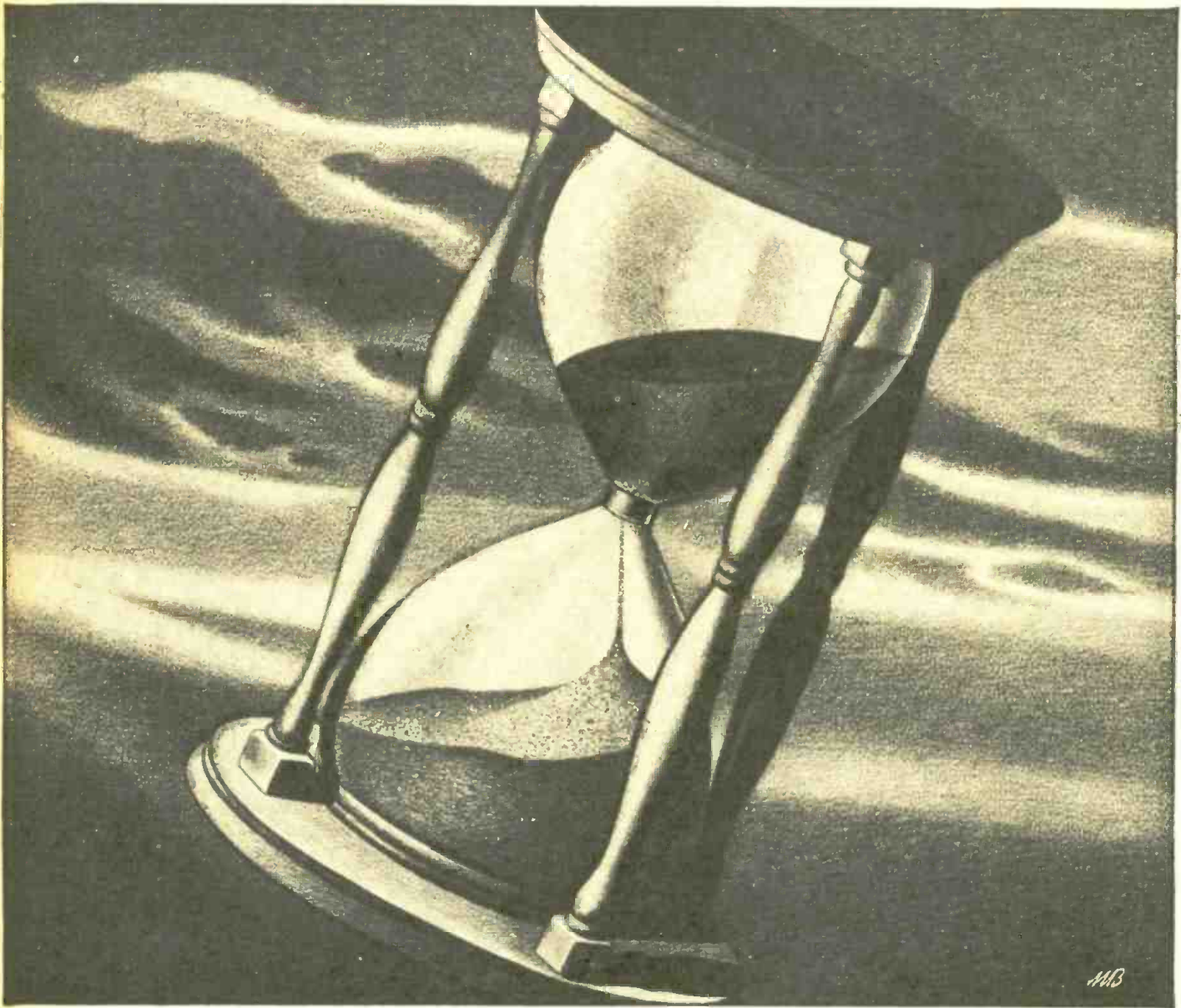

## RADIO'S ELECTRONIC HOUR-GLASS

Electrons—infinitesimal bits of electricity—are grains of sand in the hour-glass of science.

Today, radio's hour-glass—the electron tube—is turned so that the electron stream flows day and night to help win the war. Unlimited, it will run on and on until Victory is measured out on land, at sea, and in the air.



Only Time and Peace can tip this glass and reverse the flow of magic into new products and services for civilian use. Then, in the hour-glass of progress, will flow television and other new miracles of radio as the electronic sands of science flow again in new directions.



## RADIO CORPORATION OF AMERICA

PIONEER IN RADIO, ELECTRONICS, TELEVISION

RCA BUILDING, NEW YORK, N. Y.

*The Services of RCA:* RCA Manufacturing Company, Inc. • RCA Laboratories  
 R. C. A. Communications, Inc. • National Broadcasting Company, Inc. • Blue Network Company, Inc.  
 Radiomarine Corporation of America • RCA Institutes, Inc.

Streamlining

# SYLVANIA SERVICEMAN SERVICE

by  
**FRANK FAX**



**I**T'S a matter of pride with Sylvania that so many servicemen have always looked to us for the latest, best and most complete technical assistance and information.

Today scarcities of parts and materials are making the replacement problem a tough one. There are angles and situations popping up all the time unlike any you've had to face before.

So we've been busy revising and improving our technical data in the light of new conditions—to help you carry on as best you can for the duration.

Such things as the Tube Simplification Chart, for example, which details the list of Sylvania Tubes for which replacements are available, along with the substitute best adapted for each.

Or the Base Chart, which furnishes a complete cross-index of all our tube types and bases.

In addition, we have available a big array of sales helps—each designed to stir up new business for you—or to help you better serve the old business.

Look over the list below and pick out the ones you need. If your jobber can't supply you write to me, Frank Fax, Dept. C-11, Sylvania Electric Products Inc., Emporium, Pa.

- |  |  |
|--|--|
| 1. Window displays, dummy tube cartons, timely window streamers, etc. (From your Sylvania jobber only) | 16. Technical manual                         |
| 2. Counter displays  | 17. Tube base charts                         |
| 3. Electric clock signs  | 18. Price cards                              |
| 4. Electric window signs   | 19. Sylvania News                            |
| 5. Outdoor metal signs   | 20. Characteristics sheets                   |
| 6. Window cards  | 21. Interchangeable tube charts              |
| 7. Personalized postal cards featuring timely topics   | 22. Tube complement books                    |
| 8. Imprinted match books   | 23. Floor model cabinet                      |
| 9. Imprinted tube stickers   | 24. Large and small service carrying kits    |
| 10. Business cards   | 25. Customer card index files                |
| 11. Doorknob hangers   | 26. Service gorments                         |
| 12. Newspaper mats   | 27. 3-in-1 business forms                    |
| 13. Store stationery   | 28. Job record cards (with customer receipt) |
| 14. Billheads  | 29. "Radio Alert" Post-cards                 |
| 15. Service hints booklets   | 30. Radio Caretaking Hints to the Housewife  |

# SYLVANIA

**ELECTRIC PRODUCTS INC.**  
RADIO TUBE DIVISION  
Formerly Hygrade Sylvania Corporation

## "HAMS" IN DEFENSE

Dear Editor:

Today a great majority of "hams" who are 18 years of age are working in defense industries. These men are the technical staff. They test army and navy transmitters, test manufactured tubes, wire and assemble equipment. This type of work offers good pay and advancement. The "hams" even work at electrical construction. Today a "ham" need not have experience in the industry. From my own experience I found this to be true. That "ham" ticket is the only experience needed. So for you fellows who are slackers, don't feel that way, because UNCLE SAM needs you in defense. Take my advice and apply now. There is a great demand for men with a knowledge of radio.

For the fellows who do not have "ham" tickets go get your license. Start studying and speed up on the code. If you pass your exam but don't get your license write the F.C.C. explaining the situation. I am sure you will receive a letter from the F.C.C. stating that you passed the exam and your license will be sent in the near future. This letter will be sufficient proof that you are a qualified radio amateur. So fellows get started now and do your share.

JAMES CREEVAY,  
Bronx, N. Y.

(A "ham" ticket is no longer necessary in order to be useful to Uncle Sam. Young men may enlist and receive radio training in private schools before they are called to active duty. Nevertheless Mr. Creevay's advice is excellent, chiefly because real "hams" get advancements rapidly, as a rule. See Page 90 of this issue.—Editor)

## RECIPE FOR SUCCESS

Dear Editor:

I feel certain that *Radio-Craft* is the best radio technicians' magazine published, and we should support it 100% by keeping our subscriptions in force, and by telling others what a grand publication it is.

I suggest here and now, also, that we should give *Radio-Craft* subscriptions (new, renewal, and extension of present subscriptions) as Christmas presents this year.

Now a little about me:

I opened a repair shop in 1932 in the heart of the depression and have operated continuously since that time, with my shop location in the same block.

I have found that the best way to make a living from servicing radios is to use the best quality materials, do the best job possible on every set repaired, be honest, charge your customer enough to enable you to turn him out a good job.

In other words, be fair to your customer; and also be fair to yourself. As a parting shot, I'll say, don't worry about the "cut rate guys," they never last very long.

I have been ill in the hospital for the past three years, and still am. My wife has kept my shop in operation all of that time, and is continuing to do so, bless her.

I would enjoy hearing, by letter, from some of the boys in radio. I'll answer some of the letters.

ARTHUR C. MELVER,  
Ward D2 U. S. Vet's Hospital,  
Ortén, N. C.

(We admire the spirit of Mr. Melver and believe the servicing game would be lots better if there were more like him. Best wishes for your continued success, Mr. Melver, and good luck!—Editor)

## A BEGINNER IN RADIO

Dear Editor:

I am just out of high school and began my "career" education in September. In the last year or so I have become convinced that radio is the best thing for me. Radio has always fascinated me but for some reason or other nobody around here knows much about a career in radio, and I don't know where to get any information about what schools to go to and what courses to take and things like that. I have talked it over with my parents and with Prof. S. F. Davis, head of the chemistry department of John Tarleton Agricultural College. We have decided, and I agree with them, that it would be best for me to go ahead and get an electrical engineering degree and then enter radio work. We decided this because no regular college or university offers a course in radio outside of the purely technical schools. I have no personal objection to these but my parents would rather I get an all-around education instead of a purely technical one.

What I am trying to get at is that if I do follow this course it will be at least four years before I really get into radio and that seems an awfully long time for me to wait. But if I have to, I would like to get a few books that would start me out on the basic theory of radio to kind of quench my present thirst for radio. But as I have said, there seems to be no one around here that knows anything about radio, at least if they are, they are certainly keeping quiet about it. (Stephenville is a small town and there is not much chance for anybody who has really gone deep into radio to be here.)

Could you advise me as to what books to get and to read that start from "scratch" and tell you about radio in just plain English? Radio magazines have given me some information, especially *Radio-Craft*, but usually half the articles are slightly technical. That is one of the reasons I want to learn the basic things about radio so I can understand these technical terms.

HERMON F. HOLT,  
Stephenville, Texas.

(We think you will find *Radio-Craft* now has many articles suitable for beginners and experimenters; and also the *Gernsback Educational Library*, issued in ten inexpensive booklets, has been a "stand-by" for the beginner, for years. More advanced and excellent text books are advertised by many book publishers in the advertising pages in every issue of *Radio-Craft*.—Editor)

## A HOOK-UP DEPARTMENT "FAN"

Dear Editor:

It was with a great deal of pleasure and personal satisfaction that I discovered the re-opening of your Hook-Up Department. I had eagerly followed this department in the past issues of *Radio & Television* and was sorely disappointed by its exclusion from *Radio-Craft* incorporating *Radio & Television*.

However, by re-opening this department, I consider you have made a splendid gesture toward perpetuating and encouraging the spirit of constructive research and experimental development. May I extend my warmest congratulations and best wishes?

JAMES D. ALEXANDER,  
Terre Haute, Indiana.

(Thanks for your compliments, Mr. Alexander. It is receiving letters like these that help us determine what departments our readers like.—Editor)

**RADIO SERVICEMEN EXAMS**

Dear Editor:

The one outstanding feature of your magazine, as compared to the others in the radio field, is the Mailbag.

Today as I went through the last twenty issues of *Radio-Craft's* Mailbag Section, I paid particular attention to the articles dealing with the radio serviceman.

Mr. Moody, I believe, deserves a great deal of credit for arousing the servicemen. At least I will give him credit for making me more technically-minded and probably many others, who care not to admit it.

About a year and a few months ago, I would have lined myself up with the practical experience advocates who rapped Mr. Moody, such as John Klingman, Jr., and E. M. Pace. At that time I too thought that "the only way" to learn radio was by "practical experience," in fact I had already spent seven years learning in that manner. For this method I have this to say—"it sticks," but as Benjamin Franklin once said, "Experience is a dear school, fools will learn by no other." 'Tis true that a radio serviceman must learn many things in this manner, but not as many as the advocates of "practical experience" would like to believe.

Today, I believe as Mr. Moody does, and that is "The serviceman needs to be more technically minded." The understanding of many of the complex circuits in radio such as A.F.C., Phase Inverters, A.V.C., and others, demand this technical training.

In Mr. Moody's article in the May, 1941, issue of *Radio-Craft* he proposes a Radio Service Guild. To gain entrance in this guild he proposes a stiff examination in fundamentals and service technique. I agree to the examination part but as for the Guild I can only say this—*Radio-Craft* once tried it.

Taking Mr. Moody's stiff examination in fundamentals and service technique, and coupling it with Mr. Zuehl's proposal on Page 389 of the March, 1941, issue, plus an examination under federal supervision, we could form a "National Guild" that would work. It works for the amateurs and the commercial radio operators. To parallel it further to the commercial examination, a book of the type, "Study Guide and Reference Material for Commercial Radio Operators' Examinations," could be published by the Superintendent of Public Documents, for radio servicemen. The primary purpose of this book would be to cover the scope of the examination rather than furnish key answers to the examination.

I cannot see why anyone who knows his radio fundamentals would object to such an "exam," especially if it was under federal supervision. The radio set owner and many others in the radio field would also benefit from such a setup.

Something of this nature is needed and the sooner we have it the better. This would also help after the war, because there are going to be thousands of men turned loose from the Signal Corps of the Army into the Radio Servicing Field, that never thought of radio as a vocation previously.

I know that an examination of this sort would probably eliminate some who are very capable at "the bench," but these would be eligible for re-examination later. It is high time we start thinking of servicemen as a whole, rather than of the few this exam would work a hardship upon.

VICTOR LENCE,  
Amherst, Ohio.

**LICENSING SERVICEMEN**

Dear Editor:

I have read with much interest the discussions concerning licensing of Radio Servicemen.

Radio Service is a profession. As such, the men in it should assume a professional attitude. An electrician cannot install or alter electrical wiring in any community without being examined and licensed. The license he holds marks him as a man who knows his business and he gains the respect of his clients.

Radio requires far more knowledge and skill than wiring, therefore I say, license the radio man. Establish a minimum amount of theoretical knowledge and a minimum length of experience. No good man will fail in the requirements. The quack and screwdriver mechanic will not be allowed to remain in business.

Some say let the screwdriver man remain. The customer will soon find him out and will turn to the good man. In times like these can we afford to experiment with radios and other equipment which cannot be replaced?

Yours for professional licensing,  
FRANCIS M. MCKINNEY, A.I.R.E.,  
Auburn, Calif.

**WHY THE HIGH PRICES?**

Dear Editor:

Just what is the matter with Frequency Modulation?

Why are the radio parts manufacturers so secretive about the parts used in an F.M. receiver and why do they increase the price of F.M. intermediate transformers to a list price of two dollars when real iron-core I.F. transformers are selling at a dollar and twenty-nine cents?

While commercial F.M. receivers are equipped with iron-core I.F.'s, we radio builders cannot buy them. We can only purchase air core I.F.'s for the frequency modulation sets. While only about eight inches of wire goes in an antenna and oscillator coil for F.M. reception, they have the nerve to charge us fifty cents each.

Their "alibi" about being hard to make is the "oil" pure and simple!

For anybody who possesses the testing equipment that radio firms have, it certainly must be child's play. There are probably too many royalties being handed out.

JOHN CANNON,  
Mauch Chunk, Pa.

(Most of the special F.M. parts are high in price or hard-to-get simply because of the war. It must be realized that the Army, Navy and Air Force need these parts, or the materials used in them. We civilians must "take a back seat" in demanding radio parts, and try to be satisfied with what we can get.

And here is where "Yankee Ingenuity" comes in. The "make-your-own" motto should come to the fore much more than ever before.—*Editor*)

**A SATISFIED READER**

Dear Editor:

I became acquainted with *Radio-Craft* through a subscription to *Radio & Television*. *Radio & Television* was "tops" with me, but I like the new *Radio-Craft* even better.

The article, "Making a Code-Teaching Machine," was especially interesting. The column, "Radio Patents Review and Digest," is always a favorite with me. How about giving us some good technical articles on frequency-modulation and television? I would like to see a few articles on network transmission lines.

MAURICE E. WERNER,  
(address not given)

**RADOLEK-  
Headquarters  
For Essential  
REPAIR PARTS**



Thousands of progressive servicemen rely on Radolek for their complete requirements of repair materials. Make Radolek your dependable source for essential replacement and repair parts—tubes, condensers, volume controls, resistors, transformers, etc.—all at lowest prices.

Radolek understands service problems—gets delivery to you in double-quick time. Buying from Radolek means Greater Values, Better Service and More Profits. The big Radolek Radio Service Guide is FREE for the asking. Send for your copy today!

**RADOLEK P. A. SYSTEMS  
FOR EVERY REQUIREMENT**



Thousands of successful Radolek P.A. installations are proof of quality, superior design and top performance. Complete systems for permanent, portable or mobile use—wide choice of microphones, speakers and related equipment. Radolek P.A. Systems give you more for your money in Performance, Styling, Dependability and Reserve Power. Select the P.A. apparatus you need from Radolek's big FREE catalog.

**RADOLEK REPAIR SERVICE**

Let Radolek repair your damaged or burned out transformers, coils, speakers, test equipment, etc. Many items cannot now be replaced and therefore repairing is the only alternative. Trained craftsmen, using precision tools and factory methods, assure perfect jobs equal to new. Write for prices or better still, send in any article to be repaired. It will be handled promptly.

**FREE!**



**SEND FOR NEW FREE  
RADIO SERVICE GUIDE**

**RADOLEK CO., Dept. C-72  
601 W. Randolph St., Chicago, Ill.**

Please send the Big FREE Radio Service Guide.

Name .....  
Address .....  
 DEALER  SERVICEMAN  SOUND ENG

**SAVE AT RADOLEK**

# PRACTICAL RADIO INFORMATION

Including Frequency Modulation—Television, etc.)

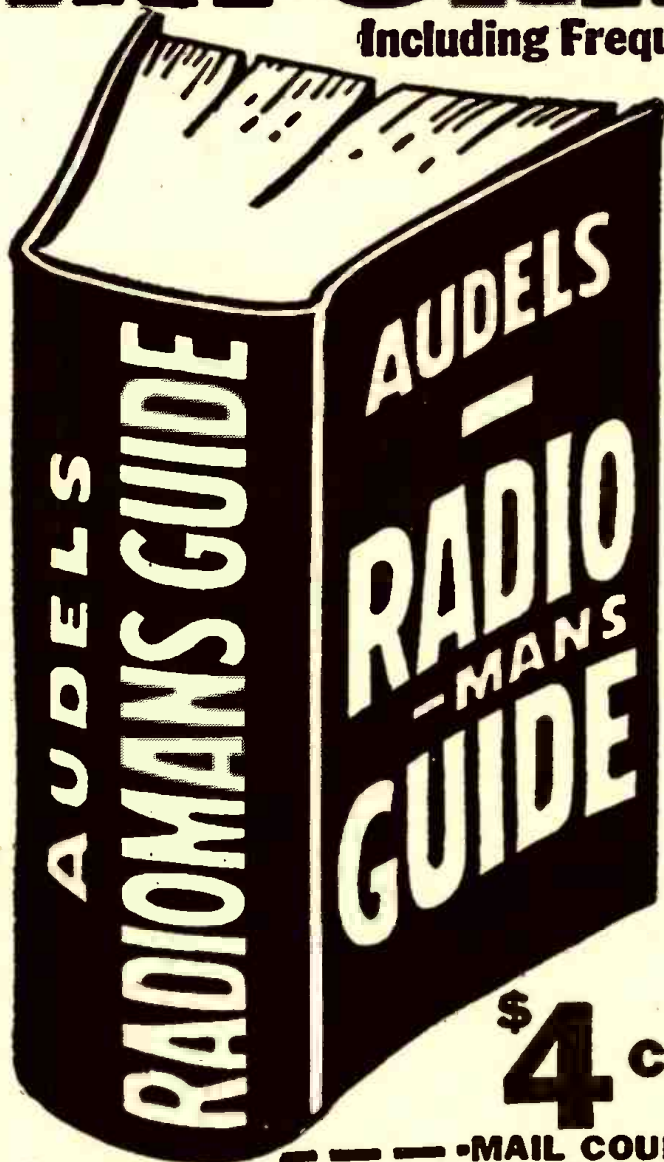

Inside Information for all Servicemen—Aircraft Pilots, Students.

**772 PAGES, 400 DIAGRAMS** is complete—gives Authentic Principles & Practices in Construction, Operation, Service & Repairs. Covers clearly and concisely Radio fundamentals—Ohm's Law—Physics of sound as related to radio science—Measuring instruments—Power supply—Resistors—Inductors—Condensers—Transformers and examples—Broadcasting stations—Radio Telephony—Receivers—Diagrams—Construction—Control systems—Loud speakers—Antennas—Auto Radio—Phonograph pickups—Public Address Systems—Aircraft & Marine Radio—Radio Compass—Beacons—Automatic Radio Alarms—Short Wave—Coil Calculations—Testing—Cathode ray oscillographs—Static Elimination—Trouble Pointers—Underwriter's standards—Units & tables. REVIEW QUESTIONS—Ready Reference Index.

**\$4 COMPLETE • PAY \$1 A MO.**  
To get this practical information in handy form—Fill in and

—MAIL COUPON TODAY.—

**AUDEL, Publishers; 49 West 23rd St., New York**  
Mail AUDELS NEW RADIOMAN'S GUIDE for free examination. If O. K. I will send you \$1 in 7 days; then remit \$1 monthly until \$4 is paid. Otherwise I will return it.

Name \_\_\_\_\_ R.C.P.

Address \_\_\_\_\_

Occupation \_\_\_\_\_

Reference \_\_\_\_\_

Please Note:  
If you do not wish to mar this page by clipping coupon—send letter or penny postcard instead.



# RADIO-CRAFT

Incorporating

RADIO & TELEVISION

"RADIO'S GREATEST MAGAZINE"

... *The 3rd Radio Boom—  
not for Profit but for  
Patriotism* ...

## THE RADIO BEGINNER IS BACK

By the Editor — HUGO GERNSBACK

**E**VER since the beginning of radio—and even before the days of radio when it was still "wireless", in those hoary days of 1903—radio has always worked in cycles.

You may remember the first boom in the old wireless days when the new art first caught the public's imagination. This was when the great steamship "Republic" collided with another vessel in the year 1909. Wireless then for the first time in history then proved the means of saving hundreds of passengers from a watery grave. An immediate boom in wireless developed, when tens of thousands of young men, and old ones as well, were bitten by what was then known as the "wireless bug". Wireless amateur-experimenters sprung up all over the country and a huge amount of old-time radio equipment was sold at that period.

Again in 1922-23 another—the second—radio boom developed, almost overnight, when broadcasting first was started. This time the boom was tremendous and it is estimated that considerably over one million people in the United States started to build radio sets, beginning with crystal detectors; later on, one-tube "bloopers"; and still later on, multiple tube sets—all home built, on a breadboard. This boom lasted several years and finally died out when manufacturers of radio sets put the home-builder out of business because it became cheaper to buy a set than build one.

Now in 1942, with the U.S. engaged in its greatest and all-out War, we are entering another radio boom, but this time a different kind of boom. As all radio manufacturers, whether they manufacture parts or sets, are now engaged to turn out radio devices for our armed forces, there is very little left to satisfy the consumer trade. Very many radio manufacturers have discontinued building civilian sets entirely, for the duration, while a few others are still manufacturing sets, but only a small percentage. Altogether, the entire radio industry manufactures only a pitifully small amount of consumer radio sets and radio parts, and the chances are that before the War is over, only a sufficient amount of radio replacement parts will be manufactured to make sure that the radio sets now in use in the country are serviced, and that they might not be silenced all together.

On the other hand, there has already been created a serious shortage of radio technicians of all classes—most urgently needed by the U.S. armed forces, whether they are in the Army, in the Navy, in the Air Corps, in the Marine Corps or in the Coast Guard. Nearly every available radio man will soon be in the service.

This great shortage of radio man-power now has its full impact on literally hundreds of thousands of men who must start from scratch and learn radio in a hurry. Men from all classes in life for some time have been flocking to radio in an ever-increasing speed in order to heed the urgent call of our Government.

The third radio boom of which we speak and which is already under way, has therefore been created directly by the War, and in recapitulating the two chief causes, we might enumerate them as follows:

- (1) The great scarcity of radio sets, parts and material.
- (2) The abnormal shortage in radio man-power due to the call to the colors of all available radio technicians.

When we speak of this—the third and perhaps the greatest radio boom—it should not be confused with the two that preceded it, because the present radio boom, unlike the two others, is not likely to create a bonanza in cash for any one.

*This radio boom is not one that deals in profit but one that deals in patriotism.* The boom is actually here. Overnight everything that is printed in radio is snapped up by eager radio beginners who wish to get letter-perfect in radio in the quickest possible time. Radio schools who teach radio—whether they are private or Government—all report a tremendous increase in their activities; so do the publishers of radio books.

The 1942 type of radio enthusiast uses his spare time to learn the rudimentaries of the radio art. This is very much like his predecessors in the other radio booms and, indeed, he does not differ very much from them with one exception and, that is, this time he is desperately in a hurry to learn radio in record-breaking time.

We are hearing from them every day during the week by letter, by telephone and by telegraph. Many requests are for simplified radio information—in other words, beginners' articles. We are happy that we are able to make our contribution to this worthy cause; and, beginning with this issue of RADIO-CRAFT, we go back to the early days of radio and are inaugurating a series of radio beginner's articles for those laymen who have to start from scratch.

In a private survey which we have made, we have found a great deal of dissatisfaction among those men who have started out to learn radio only to find that many institutions begin on a scale too high up for the layman who does not even know the fundamental workings of electricity, let alone radio. It is unfortunate that instructors cannot realize that a layman must start at the bottom of the ladder before he can get anywhere. Many instructors, who should know better, assume that the student knows all about electricity, when nine times out of ten he knows nothing about it whatsoever. We would recommend that these gentlemen start from the very beginning, because altogether too many students have complained to us that the simplest fundamentals are not being taught to them.

That is one of the reasons that prompted us to publish a series of elementary radio beginner's articles, not only from a theoretical viewpoint but from a practical viewpoint as well. We have always believed that the simplest way to learn radio is to build a simple set, or a group of sets, yourself—"Learn By Doing". This is the best, and the only manner in which radio should be taught to the more than 600,000 young men who must be trained in radio within the next twelve months.

## A Digest of News Events of Interest to the Radio Craftsman



Welders Watter Joensen and Frank Lo Preste are all smiles about the new throat microphone device, supplied to the Curtiss-Wright Corporation, Propeller Division by the U. S. Army Air Force. Now, with perfect comfort, welding instructors can communicate easily and clearly in training learners.

### THROAT MIKES SPEED UP WELDING

Our cover and the accompanying illustration show a new development of a two-way telephonic equipment which is now supplied by the Army Air Forces to welding instructors at the Caldwell, N. J., plant of the Curtiss-Wright Corporation. By this means a serious problem in speedy and efficient training has been solved.

Heretofore the instructor had to shout at the top of his voice to the pupil, who in turn had to stop using his torch and lift his protective hood to listen to the verbal instructions. This meant a loss of time in the all-important job of training new welders.

By using a new and ingenious throat microphone, heretofore used almost exclusively by the Army, the Curtiss-Wright people found a complete answer to their problem. The instructor, who now can speak in normal tones without raising his voice,

is able to communicate with the student without any interference whatsoever. The specially-designed throat microphone picks up only the speaker's voice which is transmitted, while the numerous and extraneous factory noises are eliminated altogether.

The students are equipped with a set of ear-phones which fit snugly under their protective metal hoods. The students are thus enabled to hear the instructor's voice as if they were in a quiet classroom, despite the high level of noises generated by production machinery and torches. As it is unnecessary for the students to talk back to the instructors the former do not require throat microphones themselves.

The development is another simple yet ingenious method to apply well-known sound principles towards our war effort.

### ISSUANCE OF AMATEUR STATION LICENSES DISCONTINUED

The Federal Communications Commission by its Order No. 87-B adopted September 15, 1942, has discontinued the issuance of new, renewal, or modified amateur station licenses until further order of the Commission. This action has been taken in view of the many difficult administrative problems which have arisen in connection with the issuance of amateur station licenses as a result of the war. Inasmuch as many licensees are in the military services or engaged in war industries in various parts of the country, it is impossible for such station licensees to exercise proper control of transmitting apparatus and the control of the premises upon which such apparatus is located as required by the Rules and Regulations Governing Amateur Radio Stations and Operators.

The establishment of the War Emergency Radio Service will provide Civilian Defense and State Guard organizations with the desired emergency communication in connection with national defense and security. The Commission will continue its policy in regard to the issuance of new or renewed amateur operator licenses or modification of such licenses for change in operator privileges. The holder of an amateur operator license desiring to maintain his amateur status should submit application for amateur operator and amateur station license renewal in accordance with the rules.

With respect to amateur station licenses which are valid as of the date of adoption of Order No. 87-B and are not revoked prior to their expiration, it is contemplated that the licensees thereof, who maintain valid amateur operator licenses, will be granted appropriate amateur station authorization when amateur stations are again allowed to be operated, subject to the filing of such additional application(s) as may be required. It is further contemplated that the future operation of amateur stations will be authorized upon such bands of frequencies as may then be allocated to the amateur service.

Insofar as it is possible and practicable to do so, the call letters of outstanding amateur station licenses will be reserved for assignment to the present station licensee upon proper application when licensing of amateur stations is resumed.

### RADIO RECEIVER SHORTAGE SERIOUS

Unless the government relaxes its rigid ban on the manufacture of radio set replacement parts and raw materials, millions of listeners soon will be without receiving facilities, according to a survey made by National Broadcasting Company last month.

It is estimated that there is only one year's normal stock of new radios now available to replace obsolete receivers and that the supply of radio repair parts has been practically exhausted. When this diminishing stock has been used up, it is feared that the number of "dead" sets will increase by 14,000 daily.

Approximately 60,000,000 sets were in use when production of radios ceased last June, following a WPB order. Through normal obsolescence, nearly one-tenth of these sets will become useless within the next nine months. Reserve stocks are ample to replace the majority of these aged instruments, but after the middle of 1943 dealers' shelves and floors will be bare. A large proportion of the now useless sets could be restored, it is believed, if the necessary replacement parts were available.

### NEW TELEVISION SCHEDULE FOR W6XAO

Thomas S. Lee, owner of the only operating television station on the West Coast (W6XAO), has announced that telecasts will be made alternate Mondays.

Since the current television programs include instructional and educational film and talent presentations that aid Civilian Defense and facilitate participation in the war program, the new telecast schedule will be another W6XAO contribution to unity for victory, Lee said.

Monday was selected for the bi-weekly programs after a combination radio-television survey showed it to be the "preferred stay-at-home" night among West Coast listeners and lookers. The Saturday night schedule followed up to this time had been selected for technical reasons, now no longer imperative.

With the change in schedule, Lee also announced the installation for regular operation of two new orthicon television cameras. These are the latest type cameras made by RCA on a special order placed by Lee in June, 1939, and only recently delivered.

According to Harry R. Lubcke, director of the Thomas S. Lee Television Station, these new cameras use only a small fraction of the light necessary for the iconoscope cameras. Their potential advantages have already been noted in operation, for the new orthicon cameras were tested and proved on a sneak preview on the telecast of September 5.

### NEW 100-KW. TRANSMITTER ON FULL POWER FOR WGEO

A new 100-kilowatt radio transmitter, one of the most powerful in the world, has completed extensive tests and is now operating on full power for WGEO, one of the two General Electric international broadcasting stations in Schenectady, it was announced last month by Robert S. Peare, broadcasting manager.

The transmitter replaces one of equal power released at government request last December to KWID, San Francisco, to augment the programs of KGEI, General Electric station there, and to increase California short-wave facilities to combat Japanese propaganda in the Pacific.

"The new transmitter enables the WGEO signal to cut through interference better than before and, over most of the world, should make its reception easy," said Mr. Peare.

"We have very favorable reports from Australia and New Zealand where some WGEO programs are rebroadcast.

"From the mention that Berlin has made lately of 'Radio Schenectady,' we are confident that the new signal, as well as that of WGEA, our 50-kilowatt station here, is also strong to Germany and the occupied countries of Europe."

During construction of the new transmitter, WGEO continued on the air without loss of time by the use of a previously licensed 25-kilowatt transmitter.

The station beams an English language program, including an Anzac hour and also features for American forces in the Pacific, to Australia and New Zealand, from 6 to 8 a.m., E.W.T., on 9650 kilocycles. The New Zealand National Broadcasting Service rebroadcasts the Anzac Hour on long wave.

WGEO carries English, Spanish or Portuguese programs to South America from 5 to 11:45 p.m., E.W.T., on 9530 kilocycles. Czech and English programs are beamed to Europe on the same frequency from midnight to 1 a.m.

### YING ONG—RADIO PATRIOT



Ying Ong, the young Chinese-American patriot, is seated at his desk as he is listening to a broadcast from Chungking, taking down the radio message in shorthand. He then relays the messages to all newspapers and Chinese consulates throughout the United States, thus rendering an important news service.

Our daily news broadcasts often contain the qualifying phrase: "Chungking radio says . . ." or "according to the Chungking radio . . ." etc., and this is accepted without our realizing how such word gets to us so quickly.

Well, the man who gets the credit is a young Chinese, Ying Ong, who operates a one-man listening post in Phoenix, Arizona.

This young man, a real patriot who has the interests of China at heart, started some three years ago to listen to the Chungking broadcasts on his all-wave receiver and relayed them to his fellow countrymen throughout the country, in the form of telegrams and newspaper releases, at his own expense. Even though it costs him about \$125.00 a year to do this, he absorbs the expense willingly. Chungking took official notice of his status and sent him a check for \$100.00. Characteristically he endorsed it and turned it over to the *China War Relief Fund*. He is an extremely modest young man, dead serious, and in earnest. "My work deserves no special praise," he wrote to the Editor of *Radio-Craft*. "Any radio amateur can do what I have done."

Such spirit, we feel, is like the spirit of modern China; a spirit that won't be crushed, and will fight on till victory is achieved.

Mr. Ong methodically listens-in every night, and takes down the messages in shorthand. He sends copies to the F.C.C. and to the Chinese newspapers and consulates. He exhorts his fellow countrymen in the U. S. A. to listen in on their radios to the Chungking broadcasts, and one time when such interest dropped off, he investigated and found they could not comprehend some of the dialects being broadcast. Cantonese is what most U. S. Chinese understand, so he informed Chungking accordingly, and they revised their U. S. directed beam to be in Cantonese. Interest was immediately renewed.

Madame Chiang Kai-Shek herself addressed a letter of appreciation to him, and he humbly acknowledged her recognition with thanks. Such young men as this, we feel sure, can be an inspiration to our own American boys. Best wishes for continued success. Ying Ong!

# ANALYSIS AND ALTERATION OF AN ANALYZER

By TED POWELL

## PART II—CONCLUSION

THE booklet supplied with the analyzer shows how to obtain a 150-megohm range by using an auxiliary 67½ volt battery and a one megohm 1% wire-wound series resistor is connected between the analyzer minus post and the plus battery terminal. The test leads are brought out from the analyzer plus post and the minus battery terminal. (The battery in each case is the 67½ volt battery.) The range selector knob is set to the R-times-10,000 range setting. This range can be made a permanent set-up in a revised analyzer.

The decibel ranges are actually the A.-C. ranges with a D.-C. current blocking condenser inserted in the circuit so that audio-gain or power-output checks can be made directly at the plates of audio amplifier tubes. If such tests are to be made from transformer secondaries or transmission lines, the test leads may be inserted in the

regular A.-C. volts posts and then the various reactance and dielectric losses and phase-shift effects of the condenser can be avoided, particularly at the low frequencies.

If extra A.-C. volt ranges are set up, the proper DB range value can be determined from various volt-power-decibel ratio charts available in radio magazines, texts or catalogues, or can be calculated mathematically or graphically. The booklet supplied with the analyzer has such a chart. Since the meter dial informs us that the DB calibrations were made on a 600-mw. zero DB reference level at a 500-ohm impedance, we use the 500-ohm column in the chart. If we set up a list of the analyzer A.-C. volt and DB ranges and the corresponding volts gain or loss in the chart we get the following:

10 volts	+ 8DB	4.3507
50 volts	+22DB	21.805
250 volts	+36DB	109.285
1000 volts	+48DB	435.07

Even if one is unfamiliar with DB theory, one can see at a glance that the A.-C. volt ranges are in a roughly direct proportion to the voltage values given in the voltage-value column in the DB chart. Therefore we can use simple interpolation between the analyzer A.-C. volts and the chart's volts column, get the new value of chart-column volts and then read off the new DB value (or interpolate again, if necessary). Therefore, if we were to set up a new 500-volt A.-C. range in the analyzer, we would have a DB volts gain value of twice that given for the 250-volt range, or 109.285 times 2, or 218.57 volts. Looking up this 218.57 value in the 500-ohm impedance column, we get a value of plus 42 DB. Similarly, we can find the proper DB range for any other A.-C. volt range we might care to set up in an analyzer.

This value of plus 42 DB could also be obtained graphically by plotting the five A.C. volt ranges and their corresponding DB values on logarithmic plotting paper, running off the straight-line curve and then reading off the proper DB value for any voltage within reason. Or else, it can be calculated by using the simple DB formula which can be employed where we are working between equal impedances or with the same circuit at different levels.

The manufacturer's booklet explains some other miscellaneous tests that can be made with the analyzer, such as condenser capacity checks with the aid of tapped transformers and curves, etc.

### THE HIGH-VOLT RANGES

When television, cathode-ray, transmitter and various industrial electronic circuits must be serviced, voltages considerably higher than those encountered in usual radio service work must be handled.

The manufacturer supplies a high-voltage multiplier (the "Televerter") for obtaining a 5,000-volt D.-C. range. Such a multiplier must of necessity be a costly and specially designed high-voltage unit in order to limit leakage and prevent flash-over and injury to the operator. The manufacturer points out that since the analyzer has a highly sensitive 50-μa meter, a leakage current of only 1 μa through the meter coil can cause an error of 2% and at 5,000 volts a minute leakage of several thousand megohms can cause such a relatively high error. For this reason this Televerter is made as a separate heavily insulated unit to be mounted in the compartment which the writer cut away. It cuts in on the 2.5 volt range as shown in Fig. 1. However, there appears to be no serious objection to mounting the unit within the meter compartment itself and connecting it permanently to the minus volt-amps post and to a large well-insulated plus post mounted on the analyzer panel.

2.5 volts	- 4DB	1.0928
-----------	-------	--------

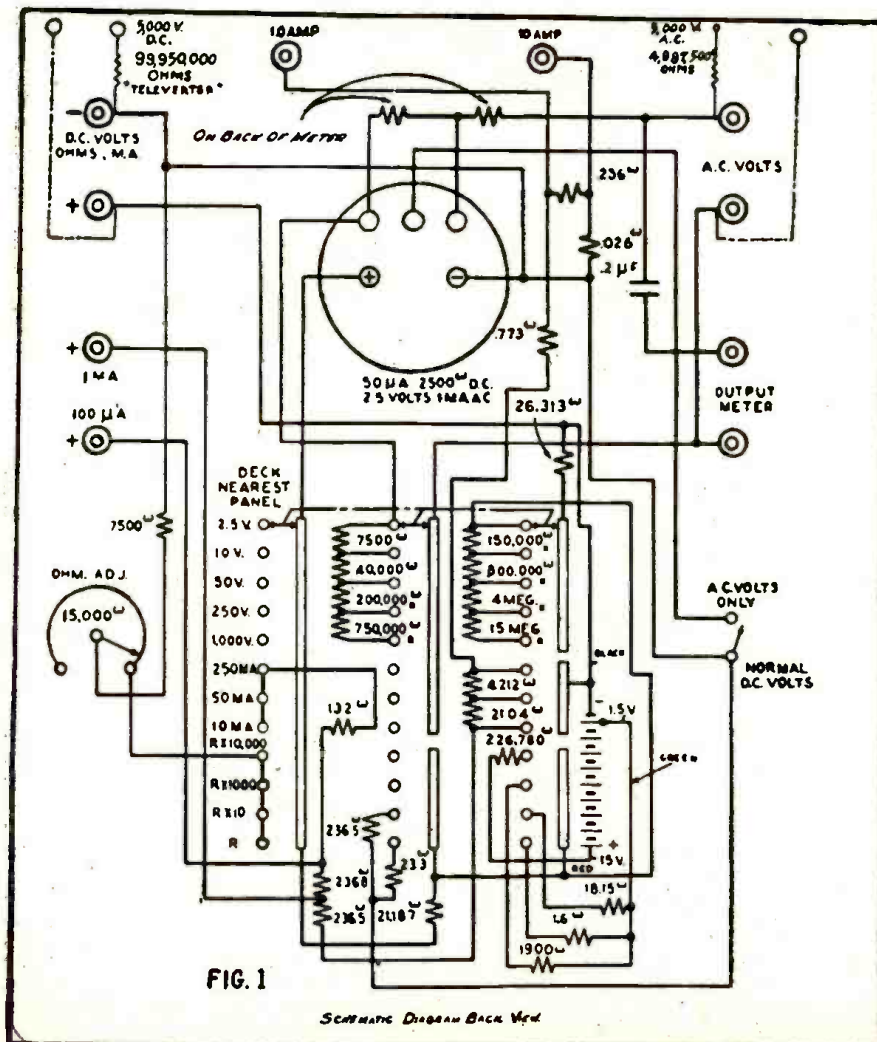

FIG. 1

SCHEMATIC DIAGRAM BACK MET

It has been done on some commercial analyzers with ranges as high as 10,000 volts (Precision—6,000 volts, Clough-Brengle—7,000 volts A.C. and 10,000 volts D.-C., etc.) A similar multiplier could be installed for a high-volt A.-C. range by allowing for peak voltage.

In the case of the 5,000-volt D.-C. range, an insulated multiplier of 99,950,000 ohms is theoretically necessary since there already is a total of 50,000 ohms in the 2.5-volt range where it cuts in on the analyzer circuits. This produces the total of 100 meg-ohms for the 5,000 volt range (100 meg-ohms times 50  $\mu$ a. equals 5,000). As already stated, this multiplier must be well insulated and A.I.E.E. standards call for twice the maximum volts plus 1,000 volts, or about 11,000-volt insulation.

In the case of the 5,000 A.C. range, we have a meter current of 1 ma. and a "resistance" of 2,500 ohms and a total circuit resistance of 2,500 ohms at the 2.5-volt A.-C. range. Under these conditions, a heavily insulated multiplier of about 4,997,500 ohms would be theoretically necessary to produce the 5-megohm total needed (5 megs times 1 ma. equals 5,000 volts). Here A.-C. peak voltages must be taken into account and A.I.E.E. standards call for about 15,000-volt insulation. However, such high standards do not necessarily have to be met in the case of intermittent-duty, low-power test equipment. Cumulative dielectric heating and breakdown stresses will not ordinarily tend to develop to the extent which they do in constant duty high-tension power transmission lines and transformers, for instance.

Generally speaking, higher voltage ranges of 7,000 or 10,000 volts in a standard analyzer are impractical because of the relatively great leakage problem involved. Specially designed equipment is generally necessary and a specially insulated meter and multipliers in a well-insulated assembly is advisable.

#### GENERAL SUGGESTIONS

Besides the above remarks, some additional suggestions are presented here for the analyzer operator and manufacturer to consider.

Most radio servicemen and lab technicians complain about inconvenient scales and small meter dials. This may sound somewhat petty but it should be borne in mind that when a man must operate an instrument continuously over eight or ten hour stretches and must take countless readings, such factors add considerably to eye-strain, fatigue, higher error percentage and decreased production. This is something to consider with all seriousness in times such as these. Five and seven inch meter dials are possible with a 50  $\mu$ a movement and their general adoption would be a boon to the professionals.

More ranges are advisable in the case of nearly all analyzers. Thus when an analyzer has no 500-volt range, an awkward-reading 1,000 volt scale must be read for the great number of 250-to-450-volt readings that must be taken in regular radio service work. This factor coupled together with a small meter dial results in quite a strain on the eyes and nerves over a day-long stretch of testing.

Again, in this particular analyzer, an R-times-100 range is omitted and an R divided by 10 and an R divided by 100 range would be of considerable benefit in radio work. Of course, very low-ohmage ranges present some difficulties but they can be overcome without too much trouble or expense. Only a part of the ohms reading scale is really useful (at the low-ohms) and all the scales are necessary for accurate readings.

The low-ohm reading scales are badly needed for various low-ohmage checks such as turn-to-turn and layer-to-layer shorts, resistance joints and erratic contacts in power transformer windings, audio transformers, audio power output secondaries, speaker voice-coils, and chokes. Then there are resistance, erratic contact and rectification joints at bolted, riveted, soldered or movable-contact connections which sometimes must be checked for elusive noise, distortion, losses and oscillation sources.

Most radio men can recall many instances of wasted hours and frizzled nerves caused by "bugs" which could have been tracked down in short order by low-ohm ranges. The writer can recall a few of his own headaches. One was a case where an auto receiver showed symptoms of intermittent oscillation and distortion and some loss of gain. Repeated analyzer checks failed to show up any faults. Oscilloscopic checks tended to indicate some trouble in the oscillator stage. Tapping about with a screw-driver brought on erratic performance. Eventually the trouble was traced to a resistance-oxidation riveted joint between the ground lead of a trimmer condenser and the chassis. A low-ohms range would have shown up the phony joint.

In another case several hours were wasted on a small midget receiver which had a peculiar case of audio distortion at the higher frequencies. Checks with analyzers again slowed up no defects. Oscilloscopic checks had to be resorted to some trouble in the output stage seemed to exist. The pliers were accidentally caught under a lead on the output transformer and the power tube plate to transformer lead parted from the transformer lug. It was a "cold solder" joint and was the cause of all the trouble. No doubt there was oxidation at the connection and some rectification distortion in the way of harmonics was present. Again, a low-ohm range would have shown up the trouble.

Another case was one where a receiver showed erratic voltage at the receiver amplifier tube plates in all stages. This resulted in varying volume, noise, occasional distortion, overheating tubes, etc. After some chasing about, it was found that the power transformer was putting out a varying voltage to the rectifier tube. By disconnecting the transformer from the receiver and loading the secondary with an appropriate resistance and checking with the analyzer again, it was found that there was some sort of a layer-to-layer short in the primary, causing the erratic voltage output and noise. The short was intermittent and made the tracing job a bit tedious. Again a low-ohmage check of the transformer windings would have located the trouble without much bother.

These three examples have been cited to show manufacturers the need for low-ohmage ranges in an analyzer.

Obviously, if any additional ranges are incorporated in the analyzer, a rotary selector switch of more than 12 positions is necessary. By using a two-switch system or else a switch with a larger diameter, the contact-to-contact gap problem can be met.

A T.P.D.T. switch and an extra pair of jacks can be incorporated in the analyzer so that the meter can be isolated for ultra-sensitive, 50- $\mu$ a. and .125-volt D.-C. readings. This would make possible convenient leakage and resistance-joint tests as well as two extra low-reading ranges. Midget relays or fuses for the protection of the meter coil might be advisable here.

The mechanical sections of the switches and potentiometers should be lubricated lightly to minimize wear.

An alternative analyzer case alteration

would be to knock out the compartment wall and employ the complete case. A new plastic panel can then be made up. The old metal panel could be removed and used as a template to mark off the new panel. The analyzer components can be mounted on the new panel as is, but with the meter rotated 90 degrees so that the new case can be stood up on the long side. The 12-position switch can be used for the R divided by 10, R, R times 10, R times 100, R times 1,000, R times 10,000, 2.5-volt, 10-volt, 50-volt, 250-volt, 500-volt, and 1,000-volt ranges. A second switch of five positions can be used for the lighter current ranges. Jacks are advisable for the heavier current ranges because the switch contacts can not stand up under these currents. The 1 ma. and 100  $\mu$ a jacks can be utilized for the sensitive 50- $\mu$ a and .125-D.-C. volt ranges in conjunction with a T.P.D.T. switch. An additional jack, a 67½ volt battery and a 1% wire-wound resistor can be installed to obtain a 150-megohm range. In the manual supplied with the analyzer the resistor and battery are hooked up in series from the extra jack to the minus volt-mils jack and the plus volt-mils jack is used as is, and the selector switch is set to the R-times-10,000 range.

There should be room for the installation of current transformers for A.C. current ranges. Jacks would be necessary, since most standard A.-C. current ranges are too heavy for selector switch contacts to handle safely. Jacks could be used for the D.-C. current ranges as well, and thus the analyzer would consistently have jacks for all current ranges and the extra selector switch can be eliminated. Thus a super-analyzer could be created which would combine all the advantages of both the Weston 772 and 750 analyzers.

The following are suggestions for combating the high-voltage range leakage problem:

Heavier, moisture-proof, asbestos-type insulation could be used for the analyzer wiring to keep down wiring leakage.

All connections could be painted over with some sort of insulation type lacquer or asphalt paint such as "Rubberoid" or "Dolp's Oil" to aid in the reduction of surface-moisture leakage.

The analyzer panel could be made of some sort of a plastic instead of metal to remove a large common conduction path.

The meter case and panel could be coated with Ceresin wax to prevent the formation of surface condensation moisture.

A small candleabra-type 115-volt socket could be installed within the analyzer case to supply warmth to keep the components dry under unfavorable operating conditions. Heavy insulated jacks mounted on small bosses in stand-off style to limit leakage between jacks might be used.

All high-voltage multipliers could be sealed in plastic tubes with high-test wax so that all connections or terminals can be sealed and leakage minimized. All voltage range multipliers could be wired in a cluster arrangement about the rotary switch itself instead of on terminal strips, and in this way eliminate many leakage paths.

Quite naturally, the cost factor is the governing element in the design of any commercial test instrument and such features both old and new as described above may be largely impractical for this reason. Furthermore, the war production program has made the design alterations of any type of equipment out of the question now. However, lab technicians and more advanced radio men can build or alter their own equipment. Perhaps later the analyzer manufacturers will consider the suggestions offered when they will again design new apparatus.

# TRANSFORMERLESS POWER SUPPLIES

By THE ENGINEERING DEPARTMENT, Aerovox Corporation

## PART II—Conclusion

### VOLTAGE QUADRUPLER CIRCUIT

When two half-wave doublers are operated in series, as in Figure 7, a practical voltage quadrupler circuit is obtained. Operation of this circuit is explained in this manner: When the lower side of the supply line is positive, diode  $V_3$  passes current, charging capacitor  $C_1$  to a voltage equal to the line peak less the drop in  $V_2$ .

When the line polarity reverses, the plate

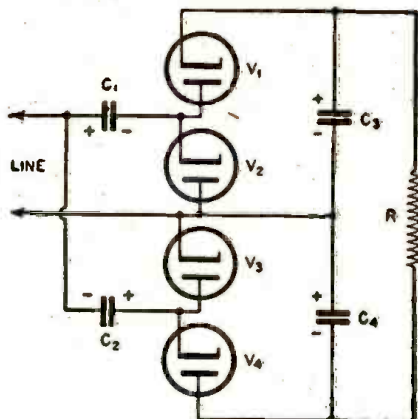

#### CAPACITOR PEAK VOLTAGES

$C_1, C_2$  LINE VOLTAGE X 1.41  
 $C_3, C_4$  LINE VOLTAGE X 2.82

AN OUTPUT FILTER CAPACITOR WOULD BE RATED AT LINE VOLTAGE X 5.64

VOLTAGE QUADRUPLER  
 FIG. 7

of  $V_1$  is positive at a potential equal to the voltage across  $C_1$  plus the line peak.  $V_1$  passes current and the capacitor  $C_2$  is charged to a voltage equal very nearly to twice the line peak.

Now, when the upper side of the line swings positive,  $C_2$  is also charged very nearly to the line peak by current passed by  $V_3$ . And when the lower side of the line swings positive,  $C_1$  is also charged by current through  $V_4$  to a voltage equal to the line peak plus the voltage across  $C_2$  less the tube drop. Thus, the voltages across  $C_3$  and  $C_4$  are each equal to a little less than twice the peak line voltage.

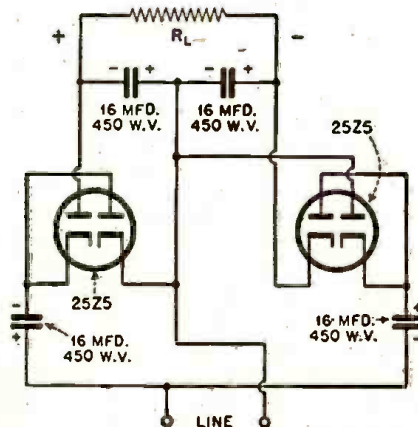

CIRCUIT OF PRACTICAL QUADRUPLER  
 FIG. 8

The final result of this action is that the total voltage presented to the load  $R$  is the sum of the voltages across  $C_3$  and  $C_4$ —approximately four times the line peak for low values of load current. Hence the term *voltage quadrupler*.

$C_1$  and  $C_2$  must be capable of handling the line peak;  $C_3$  and  $C_4$  twice that voltage. The quadrupler circuit is symmetrical and accordingly easy to filter.

Constants given in the quadrupler circuit in Figure 8 are those arrived at in an experimental setup by the editors. Performance of this practical circuit is shown by the output voltage-load current curve, Figure 9.

The quadrupler is not the ultimate in voltage-multiplying circuits. The principle may be even further extended. Practical circuits have been set up to multiply the line voltage by six, eight, and ten without transformers. However, the voltage regulation of these chain-type circuits is poor, and the heater-cathode potential at the high-voltage end of the string will greatly exceed the maximum value permissible for a given tube, giving rise to immediate or at least premature breakdown.

It is seen from the foregoing explanations that in all transformerless voltage-multiplying circuits capacitors are separately charged and then permitted to discharge in

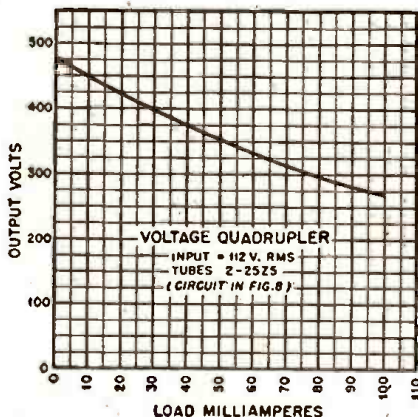

FIG. 9

series. The operation of switching these capacitors alternately into charging and discharging positions is performed automatically by the tubes.

### BRIDGE RECTIFIER CIRCUIT

A simple transformerless bridge rectifier circuit is shown in Figure 10. This unit is a full-wave supply which does not give a "hot" connection back to the power line. The bridge rectifier is particularly advantageous for supplying power to certain test instruments, such as oscillators and vacuum-tube voltmeters, which do not require high plate voltages but demand compactness and economy. Another distinguishing feature of the bridge rectifier circuit is that the two tubes operate in series and a line voltage of twice the ordinary value may be used when desired, provided that the filter capacitors can withstand the higher output voltage.

Operation of the bridge circuit takes place

in the following manner: When the upper side of the power line is positive, diode 1 of the upper tube passes current, charging the input filter capacitor, through diode 4 of the lower tube, to the line peak voltage less the drop through the two diodes.

Upon reversal of the line polarity, diode 3 of the lower tube and diode 2 of the upper

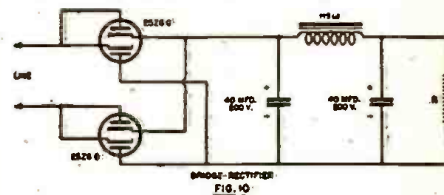

FIG. 10

tube pass current, again charging the input capacitor.

Thus, both halves of the supply-voltage cycle are utilized and full-wave rectification thereby secured. The ripple voltage across the capacitor is at twice the line frequency and therefore may be filtered as easily as the output of a full-wave rectifier. The input capacitor, like the same unit in the half-wave rectifier circuit, need be capable of withstanding only the line peak voltage.

Constants given in the circuit diagram are those employed by the editors in a test circuit, and the curve of Figure 11 is the output voltage-load current characteristic obtained with those values.

### CONSTRUCTION AND OPERATION NOTES

Transformerless power supply circuits do not generally require mechanical and electrical treatment different from that common to other types of power units, except that care must be taken to ventilate these units. The tubes designed for this service have high-voltage heaters and their envelopes radiate considerable heat. The high-capacitance electrolytic capacitors may soon become damaged from exposure to the heat. At the same time, the powered unit might have its operation impaired by the heat generated by the power supply. It is strongly recommended that the transformerless power supply be located near ample air

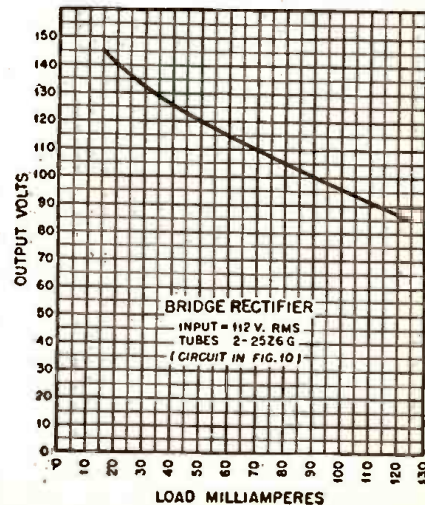

FIG. 11

vents judiciously placed in the instrument or receiver case.

In any of the circuits described in the foregoing discussions, larger output currents may be obtained by connecting two or more tubes in parallel wherever one tube is shown in the diagram. Voltage regulation may be improved to some degree by the use of larger filter capacitances than those specified, and still further by means of small gaseous voltage regulator tubes, such as types VR75, VR90, VR105, VR150, and 874, used singly or in an appropriate series combination. Rectifier tubes of full-wave separate cathode type of construction may be employed in any of the circuits in which a number of separate diodes is indicated. By doing so, two effective tubes are made available in each envelope, providing compactness and ease of replacement.

The high-voltage heaters of tubes designed principally for transformerless power supplies are connected to the line through a suitable dropping resistor (often built directly into the line cord, in order to remove heat sources from the chassis) or to the other heaters connected in series in the powered circuit. When the series heater arrangement is employed in a radio receiver, the tubes must be placed along the string in a preferred sequence in order to minimize the hum due to heater-cathode leakage. The rectifier tube, being able to withstand the highest value of heater-cathode voltage, is placed first in the series string, closest to the line and farthest from ground. One

transformerless supply tube—type 117Z6-GT—has a 117-volt heater that may be connected directly across the A.C. line without a dropping resistor. This tube enables the construction of transformerless power supply units of extreme simplicity and economy.

It will be observed from the circuit diagrams in this article that most transformerless power supply circuits provide a dangerous connection back to the power line. Often, in the case of the simple half-wave line rectifier used most frequently in midget radio sets, this "hot" connection is likewise the B-minus point or chassis ground. In such an arrangement, any negative point in the circuit is at line potential. When the negative return is thus common to the chassis (and metal cabinet), there is grave danger of electric shock and fire.

Every possible precaution should be taken in the design of equipment to be powered by transformerless supplies to guard against shock to the operator and accidental grounding of the power line. It is urged that the bridge circuit of Figure 10 be used whenever possible in test instruments, in preference to the other circuits.

When experimenting with transformerless voltage multiplier circuits, such as the tripler, quadrupler, and higher-order multipliers, the operator must bear in mind that the circuit will most certainly deliver a voltage equal to several times the line peak, when supplying a light load. The extreme compactness of the transformerless multiplier, together with the conspicuous absence

of heavy iron-core components usually associated with dangerous high-voltage equipment, tends to reduce the operator's alertness to the high-voltage danger.

For the benefit of designers of transformerless power supplies, a tube table has been supplied in Part I of this article, this article, listing the principal characteristics of all the tubes designed especially for transformerless operation. In addition to the rectifiers listed in this table, the following types combine a transformerless rectifier in the same envelope with an output amplifier: 12A7, 25A7-G, 25A7-GT, 32L7-GT, 70L7-GT, 117L7-GT, 117M7-GT, 117N7-GT, and 117P7-GT. The heater voltages of these tubes are evident from the first part of the type number.

—Aerovox Research Worker

**CORRECTION**

The following diagram was erroneously omitted from Part I of this article, which appeared in the October issue.

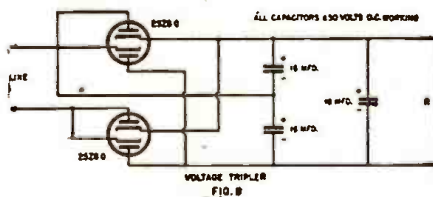

**Servicing Notes**

**Trouble in . . .**

**ADMIRAL 4A, 4D, 4F**

Weak reception on the low frequency end of the dial is a very common complaint. These sets have no low frequency trimmers, therefore, tune set to a weak broadcast signal around 600 kc. and vary the I.F. frequency until the best reception is obtained; then retune the high frequency Osc. and R.F. trimmers. In nine out of ten cases this cures the complaint.

**ADMIRAL P5, XP5**

Lack of reception or intermittent reception in these models is often caused by the battery/electric switch. To remedy this clean switch contacts with carbon tetrachloride and spring contacts to make better connection. With the failure of one-half of the filament of the 3Q5 tube, this set will not function on electric light lines, but has no noticeable effect when on battery.

**ADMIRAL 5X**

No reception on this set is often caused by failure of the oscillator coil. If replacement is not available, it is a simple matter to rewind this coil, being sure to use new wire of the same size and with the same number of turns as the original coil.

**FIRESTONE R3121 (R312)**

Hum in this set is usually caused by open filter condensers. Poor tone is often caused by leaky coupling condenser from plate of the 6Q7 tube to the grid of the 25L6 tube. Open resistor or resistors in the grid circuit of the 25L6 tube has the same effect.

Loy DUNCAN,  
c/o Palm Beach Mather Co.,  
W. Palm Beach, Fla.

**PHILCO 41-100 (and others using 1A5 tubes)**

Due to the extremely high plate load resistance of the 1A5 tube and the low current drain, the output transformers on these sets may be wide open and the set still perform. About the only difference noted will be slightly weaker reception with poor tone at medium and high volume. Replace the transformer, using one suited for a tube of 25,000 ohms plate load.

**PHILCO PT61**

Complaint: hum or poor tone when tuned to the station. Try disconnecting the A.V.C. lead from the rectified socket. Some of these sets had the A.V.C. circuit tied to a dead lug on the rectifier socket and the slight leakage, especially in damp weather, causes the above complaint.

**PHILCO 38-4**

No reception on this set may be caused by the primary winding shorting to the secondary, throwing 200 volts to the grid of the 6U7 tube. This is caused by insulation breaking down on the tickler coil. This is easily repaired. First remove the S.W. coil (the set upside down on the bench, the right hand coil toward the rear of the chassis), being sure to mark down which is grid and which is B-plus. Next carefully remove the wax from the primary winding. At the grid connection find the wire that seemingly goes into the primary winding. This wire goes into a slot, down under the primary coil form and comes up beside the primary winding opposite the plate lead, going around the coil for one-half turn to a dead end. Remove this and replace. Return coil to set and job is completed.

**ZENITH 5G636, 5G635**

Intermittent reception on these sets is often caused by dirt and corrosion on the tube base pins, or by the contacts of the sockets losing their tension. To correct this trouble tighten the contacts by forcing them together with the point of an ice pick, then rock the tubes back and forth several times to clean the dirt off the pins. No reception

is often caused by the output transformer going bad.

Loy DUNCAN,  
c/o Palm Beach Mather Co.,  
W. Palm Beach, Fla.

**EC-1 ECHOPHONE**

This receiver is not equipped with flywheel tuning. But if two races of roller bearings about three inches in diameter and three-eighths of an inch wide can be secured they will serve excellently as flywheels. All you need to do is take the receiver out of its chassis, take off the two retaining washers that hold in the dial shafts and slip the shafts out. Then to increase the diameter of the shaft just wrap a little friction tape around it and force on the bearing. In order to keep the outer rim of the bearing from turning take a punch and crimp the grease retaining washers. The bearing I used was out of an airplane engine. In other types of bearings you could fill the space with molten solder or lead. This would also increase the flywheel effect. Put the shafts back in and crimp on the washers with pliers and the job is done.

The effect obtained is strikingly like that on the more expensive model EC-3 receiver. This could be adapted to other receivers with similar changes. I find the tuning much easier now.

Pvt. Dale E. Petty,  
7th Reconnaissance Sq.,  
France Field, C. Z.

**1942 RECORD CHANGERS**

Quite often the set screws that adjust the arm for proper landing cannot be set because of the groove in the pivot shaft made by the original setting. To effect a permanent repair, take out the pivot shaft and file the grooves clean and fill in with solder. Re-assemble and you can now easily set the set screws in the right place without them slipping back into any previously made depression.

R. Rubin,  
Minor's Radio & Electric  
Service Co.,  
Baltimore, Md.

PHILCO RADIO PHONOGRAPH MODELS 42-1010, 42-1011W, 42-1011M

Connecting Aligning Instruments

Either a vacuum tube voltmeter or an audio output meter may be used as a signal indicator when adjusting the receiver.

**Vacuum Tube Voltmeter:** To use the vacuum tube voltmeter as an aligning indicator, make the following connections: Attach the negative (-) terminal of the voltmeter to any point in the circuit where the A.V.C. voltage can be obtained. Connect the positive (+) terminal of the vacuum tube voltmeter to the chassis.

**Audio Output Meter:** Terminal No. 1 is provided on the loop aerial panel for connecting one lead of the audio output meter to the voice coil of the speaker. The other lead of the meter is connected to the chassis. When using these connections, the lowest A.C. scale of the meter must be used. (0 to 10 volts.)

The audio output meter can also be connected between the plate of the output tube and the ground of the chassis.

**Signal Generator:** The radio can be aligned in the cabinet or removed from the cabinet. When adjusting the "I.F." padders, the high side of the signal generator is connected through a .1 mfd. condenser to the lug on the aerial section of the tuning condenser. The ground or low side of the signal generator is connected to the ground of the receiver.

When aligning the R.F. padders with the radio in the cabinet, a loop is made from a few turns of wire and connected to the signal generator output terminals; the loop is then placed two or three feet from the loop of the cabinet. If the radio is aligned outside of the cabinet, without the loop connected an aerial input transformer, Part No. 76-1134 will be required. Insert the transformer into the external aerial socket on the rear of the chassis. Connect the high output terminal of the signal generator to the terminal on the transformer. Connect the ground terminal to the chassis.

After connecting the aligning indicator, adjust the compensators in the order shown in the tabulation below. Locations of the compensators are shown below. If the output meter pointer goes off scale when adjusting the compensators, reduce the strength of the signal from the generator.

**Note A—Dial Calibration:** In order to adjust the receiver correctly, the dial must be aligned to track properly with the tuning condenser. To adjust the dial, proceed as follows: With the tuning condenser closed (maximum capacity), set the dial pointer on the extreme left index line at the low frequency end of the broadcast scale. The arrangement of the drive cable in this position is shown in the schematic.

**Note B—**When adjusting the low frequency compensator of Range One (Broadcast) or the aerial padders of the high frequency tuning range; the receiver Tuning Condenser must be adjusted (rolled) as follows: First, tune the compensator for maximum output, then vary the tuning condenser of the receiver for maximum output. Now turn the compensator slightly to the right or left and again vary the receiver tuning condenser for maximum output. This procedure of first setting the compensator and then varying the tuning condenser is continued until maximum output reading is obtained.



This de luxe console model with 12-inch dynamic speaker, has a built-in aerial for all-wave reception.

imum output reading is obtained.

**Note C—**To accurately adjust the high frequency oscillator compensator to the fundamental instead of the image signal, turn the oscillator compensator (5B) to the maximum capacity position (clockwise). From this position slowly turn the compensator counterclockwise until a second peak is obtained on the output meter. Adjust the compensator for maximum output at this second peak.

If the above procedure is correctly performed, the image signal will be found (much weaker) by turning the signal generator dial 910 KC above the frequency being used on any high frequency range.

The aerial padder (5A) must be adjusted to maximum by rolling the tuning condenser. If two signal peaks occur when turning the padder, adjust the maximum output on the first signal peak from the tight position (screw all the way down) of the padder.

**Phonograph Reproducer Adjustments**

To reproduce the sound from a record, the light beam of the reproducer must be carefully positioned on the light sensitive cell. If the light beam is not carefully set, the sound reproduction will be distorted, weak or, if the light beam is completely on or off the cell, the phonograph will be silent.

If any of these conditions exist, the following adjustment procedure should be made:

**Note—**These adjustments should be made with the power line voltage at 117 volts A.C.

**A. Adjusting Width of Light Beam**

To make this adjustment push the lamp socket assembly into its holder until a clear image of the lamp filament appears on the light cell. The socket should then be slightly pushed in beyond this point until the rectangular spot of light is 5/82" in width. The socket assembly is now rotated so that

the spotlight is vertical.

**B. Positioning the Light Beam**

To position the light beam on the light cell, turn the adjusting screw at the lower left side of the reproducer until the spot is half on the cell and half on the metal frame surrounding the cell.

**C. Adjusting Intensity of Lamp**

When shipped from the factory, the lamp of the reproducer is adjusted for best operating efficiency. The intensity of the light from the lamp is adjusted by Compensator No. 17 located on the radio chassis. Under ordinary circumstances, an adjustment will not be necessary. When replacing the reproducer or lamp, however, it may be necessary to readjust the light intensity. In this case the compensator is adjusted as follows:

1. Turn volume control on full and play a record.
2. While the record is playing, turn Compensator 17 in the direction necessary to get the best operating point without distortion. By turning the compensator the strength of the pick up output is increased or decreased.

**D. Installing New Lamp**

When installing a new lamp in the socket, there are two positions in which the lamp can be inserted. Ordinarily, either of these positions can be used. In some cases, however, due to the lamp filament being off center, the lamp must be inserted in the position that gives the best centering of the spot of light on the vibrating mirror.

**Radio Section**

The radio incorporates the Philco Built-in Super Aerial System for reception of standard broadcasts and Short-Wave stations; electric push-buttons for automatically tuning stations in addition to manual tuning; three tuning bands covering 540 to 1720 K.C., 2.3 to 6.7 MC and 9 to 15.5 MC; two I.F. amplifier stages; two variable tone controls which vary BASS and TREBLE audio frequencies; automatic volume control; push-pull beam power pentode audio output stage; PHILCO LOKTAL tubes; and a 12-inch concert grand balanced field Electro-dynamic speaker. In addition these models are designed to receive the sound of a television program tuned in by special Philco television radios.

Intermediate Frequency: 465 KC.  
Power Supply: 115 volts, 60 cycle A.C.

**Phonograph Section**

The phonograph of each model consists of the PHILCO automatic Record Changer with a stroboscope pitch and tempo control and a dual speed motor that can be adjusted to play not only normal speed records (78 RPM) but also slow speed records (33 1/3 to 39 RPM); the Philco Photo-Electric Reproducer with a floating jewel which reproduces sound on a beam of light, and a special phonograph amplifier stage for operation through the push-pull output tubes of the radio. The automatic record changer plays 12 ten-inch or 10 twelve-inch records at one loading. The automatic record changer is also equipped with provision for attaching a Philco Home Recording Unit Model HR-2 for making phonograph records in the home. The Home Recording Units can be obtained from your Philco distributor with complete instructions for installation and operation.

Operations in Order	SIGNAL GENERATOR		RECEIVER			SPECIAL INSTRUCTIONS
	Output Connections to Receiver	Dial Setting	Dial Setting	Control Setting	Adjust Compensators in Order	
1	Lug Aerial Section of Tuning Condenser	455 KC	580 KC	Vol. Max. "Brdcst" Push-button IN	50A, 41A 40B, 40A	
2	Use Loop on Generator or Aerial Trans.	1500 KC	1500 KC	Vol. Max. "Brdcst" Push-button IN	5E, 5	Note A
3	Use Loop on Generator or Aerial Trans.	580 KC	580 KC	Vol. Max. "Brdcst" Push-button IN	5D	Roll Tuning Condenser Note B
4	Use Loop on Generator	Repeat Operation No. 2		Vol. Max.	5C	
5	Use Loop on Generator	6 MC	6 MC	"Police" Push-button IN		
6	Use Loop on Generator	15 MC	15 MC	Vol. Max. "S.W." Push-button IN	5B, 5A	Note C



# Radio Service Data Sheet

327

### PARTS LIST

- CONDENSERS**
- 6—10 mmf.
  - 8—1 mf., 400 volts
  - 9—0.05 mf., 400 volts
  - 11—Mica 500 mmf.
  - 12—Mica 250 mmf.
  - 13—Mica 375 mmf.
  - 14—Mica 500 mmf.
  - 15—Mica 2500 mmf.
  - 16—Mica 185 mmf.
  - 21—Mica 375 mmf.
  - 22—Mica 185 mmf.
  - 24—Mica 185 mmf.
  - 25—Mica 185 mmf.
  - 27—Electrolytic 8 mf., 475 volts
  - 32a—Electrolytic 8 mf., 475 volts
  - 35—0.1 mf., 400 volts
  - 36—Mica 250 mmf.
  - 38—0.05 mf., 400 volts
  - 39—0.05 mf., 200 volts
  - 43—0.05 mf., 200 volts
  - 46—Electrolytic 10 mf., 25 volts
  - 49—0.015 mf., 1000 volts
  - 52—0.1 mf., 600 volts
  - 53—Mica 100 mmf.
  - 56—0.03 mf., 1000 volts
  - 59—0.1 mf., 400 volts
  - 60—Mica 100 mmf.
  - 61—Mica 100 mmf.
  - 62—0.1 mf., 400 volts
  - 65—0.1 mf., 400 volts
  - 70—0.1 mf., 400 volts
  - 71—0.1 mf., 400 volts
  - 76—0.01 mf., 1000 volts
  - 82—Electrolytic 18 mf., 475 volts
  - 85—0.1-.01 mf.
- RESISTORS**
- 7—33,000 ohms
  - 9—150,000 ohms
  - 10—15,000 ohms
  - 11—33,000 ohms
  - 14—22,000 ohms
  - 15—10,000 ohms
  - 33—15,000 ohms 1 watt
  - 34—2.2 megohms
  - 35—1700 ohms
  - 36—1700 ohms
  - 42—330 ohms
  - 43—100,000 ohms
  - 44—220,000 ohms
  - 45—3300 ohms
  - 46—470,000 ohms
  - 51—470,000 ohms
  - 54e—100,000 ohms
  - 57—2.2 megohms
  - 58—1 megohm
  - 64—10 megohms
  - 65—220,000 ohms
  - 66—47,000 ohms
  - 67—4700 ohms
  - 68—1 megohm
  - 72—470,000 ohms
  - 73—470,000 ohms
  - 74—56,000 ohms
  - 75—470,000 ohms
  - 82—Bias 10-20-120 ohms model 42-1011 only. Socket of Assembly Jewel Light.

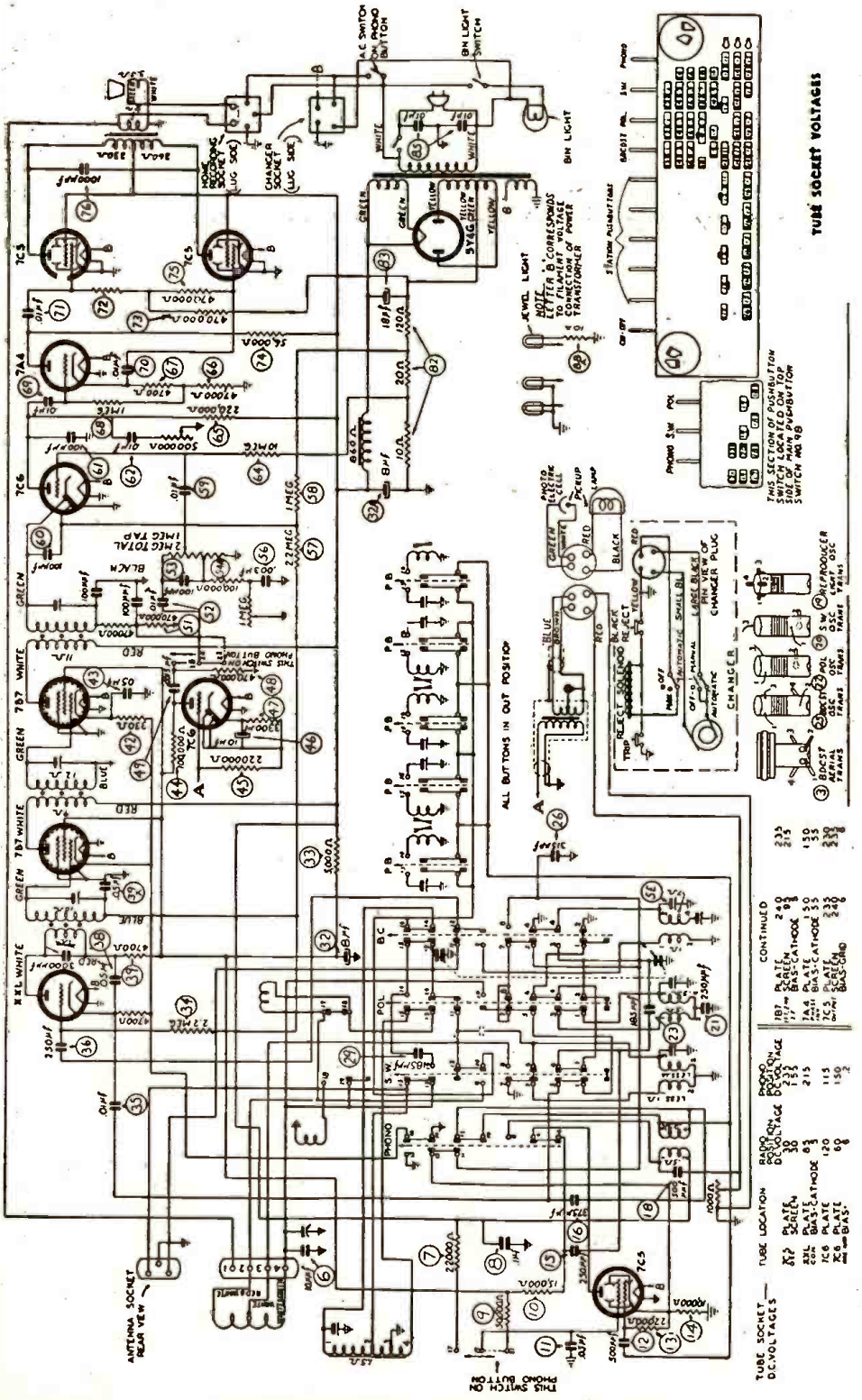

D.C. voltages indicated at the tube elements in the diagram were measured with a 1000 ohms per voltmeter. Philco Model 027, using the 300-volt scale line voltage 117 volts A.C., no signal being received—range switch broadcast.

### LOCATIONS OF COMPENSATORS

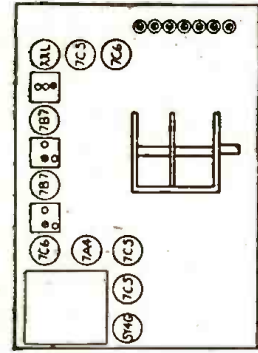

### LOCATION OF PARTS

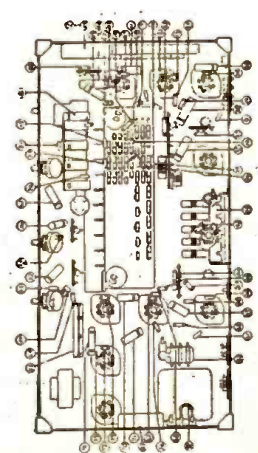

### PUSH BUTTON LOCATIONS

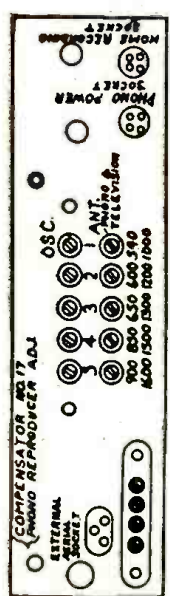

**TUBE SOCKET D.C. VOLTAGES**

TUBE SOCKET	TUBE LOCATION	GRID	CONTROL	SCREEN	PLATE	BIAS
7A4	8P	240	240	240	240	240
7C6	11	135	135	135	135	135
7C5	12	115	115	115	115	115
7C3	13	115	115	115	115	115
7C7	14	115	115	115	115	115

**CONTINUED**

10B	10B	240	240	240	240	240
11	11	135	135	135	135	135
12	12	115	115	115	115	115
13	13	115	115	115	115	115
14	14	115	115	115	115	115

# QUAL FY-AT HOME-QU CKLY

for your pick of the 200,000 RADIO JOBS in the Armed Forces, Commercial Broadcasting & Industry.

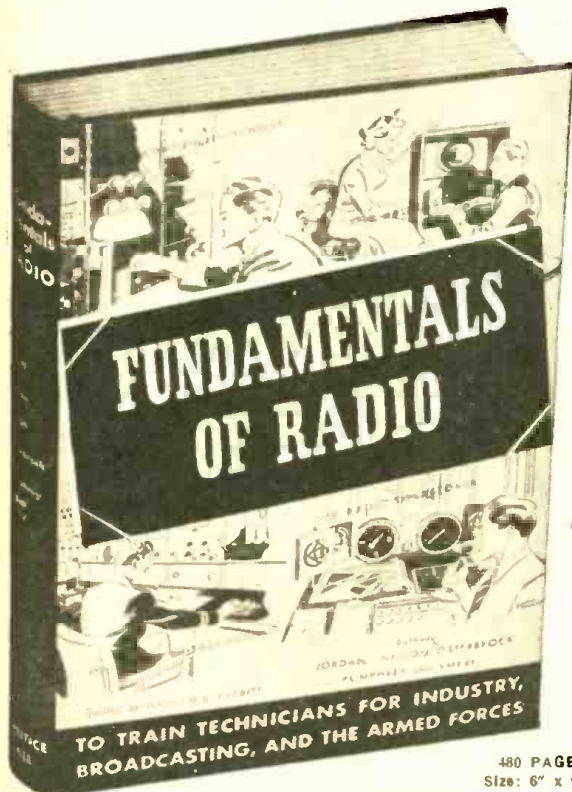

480 PAGES  
Size: 6" x 9"

**Use this Standard New Home Course in BASIC RADIO COMMUNICATIONS to brush up and meet today's requirements**

**I**F you want to prepare yourself for a radio post in advance of induction or enlistment in the military services—if you want to get into radio broadcasting or into the radio industry—here is the book that will give you the basic training you need. FUNDAMENTALS OF RADIO trains you in the entire field of basic radio communications, from the simplest circuits right through FM transmission. No previous experience is necessary. This easy-to-grasp home course is written not for engineers, but for student technicians who must know how to maintain and operate all types of radio apparatus, and have only a limited time in which to master the required essentials.

### "The One Book Unique In The Radio Field"

"With this one volume alone, men with no previous radio experience or knowledge can . . . obtain a thorough grounding in radio principles. In thoroughness, this book is outstanding . . . in the authors' appreciation of the reader's outlook and problems . . . the one book unique in the radio field."

—Scientific American.

"For many years, I've sought an adequate answer to the oft-repeated question, 'Where can I find a book which, in one volume, will teach me the fundamentals of radio?' This book is the answer I've waited years to have."

—E. K. Cohan, Director of Engineering, C.B.S.

"Anyone mastering the contents of FUNDAMENTALS OF RADIO should possess all the preliminary requirements of radio men and technicians for military and naval service."

—E. E. Tierney, Chief Instructor, Eastern Radio Institute, Boston, Mass.

**COMPLETE TRAINING FOR TODAY'S IMMEDIATE NEEDS . . .**

*Here is a glimpse of your instruction in basic radio communications*

Concise Review of Radio Mathematics—A. C. and D. C. Circuits—Power, Energy, Fuses, Batteries, Electromagnetism, Generators, Meters, Transformers, Rectifiers, Resonance Testing, Voice and Music Waves—Electronic Principles—Rectified Power Supplies—Sound and Electrical Transmission—Sound, Distortion, Microphones—Reproducers—Telephone—Loudspeakers—Audio Amplifiers—Public Address Systems—Vacuum-Tube Instruments—Oscillators—Electromagnetic Waves—Radiation and Reception—Antenna Structures—Transmission—Radio Frequency Amplifiers and Detectors—Input and Output Circuits—Amplitude Modulation Radio Transmitters—Radio, Audio Frequency Section—Crystal Oscillators—Buffer Amplifiers—Modula-

tors—Transmitter Circuit—Radio Frequency Section—Amplitude Modulation Radio Receivers—Frequency Modulation, General Principles, Wide-Band FM and Static Eliminators—FM Systems for Communication Services—FM Transmitters and Receivers—Radio Wave Propagation—Polarization—Static and Man-Made Noise—Ultra-High-Frequency Propagation—Diffraction—Refraction—Functions of Radio Antennas—Types—Directional Antenna Systems—Radio Beacons—Direction Finders and Radio Compasses.

**OVER 300 WORKING DIAGRAMS**  
from the simplest circuit to FM transmission

With any sort of past interest in radio as a background, your chances of landing a big-pay, big-opportunity job were never so bright. In the land and naval forces, in aviation, commercial broadcasting, police airways and the manufacturing industry, the shortage of radio technicians is acute, the rewards exceptional. Now is the time to give yourself the rapid basic training in radio communications which qualifies you without delay. FUNDAMENTALS OF RADIO provides exactly that training—at home—in your spare time—without wasting effort on non-essentials—without omitting any of the essentials required in actual practice. In one handy, easy-to-master volume, written by six high-ranking instructors, FUNDAMENTALS OF RADIO covers everything you need to know about basic radio communications.

### MONEY-BACK GUARANTEE

PRENTICE-HALL, Inc.  
Dept. FR-6, 70 Fifth Ave., N.Y.C.

Please rush copy of FUNDAMENTALS OF RADIO. I enclose \$5, plus 10c postage. If, within 5 days, I decide not to keep this book, I am free to return it for refund of the purchase price.

NAME .....

ADDRESS .....

CITY & STATE .....

SEND C.O.D., plus few cents postage charges. (Same refund guarantee.)

Clip this coupon or order by letter, addressing Dept. FR-6, as above.

### FREE 5-DAY OFFER

Every minute counts! Don't postpone your opportunity for a good job now and the foundation for a highly successful future in radio. Get started by mailing the coupon at once on our 5-DAY-MONEY-BACK-OFFER. Read, study, examine FUNDAMENTALS OF RADIO for five days—free. Return the book for refund if you do not find it the easiest way to qualify, at home, quickly, for one of the 200,000 radio jobs now waiting for men to fill them.



• William L. Everitt, Ph.D., Editor, Senior Consultant on Air Communication and Director of Operational Research Section in Signal Corps, U.S. Army; Professor of Electrical Engineering, Ohio State University; Fellow of AIEE and IRE; member of Board of Directors and Board of Editors of the Institute of Radio Engineers.

• Lynne C. Smeby, Consultant on Air Communication, Signal Corps; U.S. Army; formerly Director of Engineering for National Association of Broadcasting; member of Board of Editors of Institute of Radio Engineers.

• William Carl Osterbrock, Professor of Electrical Engineering, University of Cincinnati.

• Fred H. Pumphrey, Curriculum Adviser, Signal Corps, U.S. Army, Professor and Head of Electrical Engineering, Rutgers University.

• Paul H. Nelson, Ohio State University; formerly radio engineer for Westinghouse Electric, RCA Victor and other firms.

• Edward C. Jordan, Ohio State University; research work in antennas and impedance matching systems; consultant on transmitters and radiating systems.

**Let these experts fit you rapidly for big pay now—and for a post war future in radio.**

# MAKING ANALYZER ADAPTERS

By DICK BOOTH

**B**ECAUSE of existing priorities on new test apparatus, substitutions or remodeling are in order. This data on analyzer's supposes that there undoubtedly are lots of old analyzers still existent, or perhaps just the analyzer plug and adapters. Mine was made with an old 7-point plug.

With the adaption described eight-prong tubes can also be checked. The only changes that would need to be made on an old analyzer are: (1) Cut off the cable and substitute an octal socket on the analyzer panel. (2) Connect the socket to the wires that formerly went to the cable. (3) Attach an octal plug to the cable. The analyzer is now used as before with the octal plug inserted in the octal socket.

To adapt the analyzer for eight prong tubes, additional sockets are wired in the analyzer panel and additional cables made up, each of which has an octal plug to insert in the octal socket used for the cable. The other end of the cable is then terminated in whatever sort of plug is necessary to fit the tube socket to be analyzed. No details are given since each case will be different—some may need only an octal cable, since their needs will be satisfied; while others may require octal, octal, etc. Tube bases may be used for plugs, or some may be able to obtain adapters so that only the one additional cable will be necessary.

This obviates scrapping an otherwise useable analyzer which has no provision

for the newer tubes. For those who have only the plug and adapters and wish to build their own analyzer, I have shown a diagram for switch control to facilitate taking readings without moving the meter leads each time. By opening the leads through the switches or by push buttons if so constructed, and pressing the milliammeter or voltmeter button, the reading can be taken. The ganged switches determine which circuit the meters are cut into. The voltmeter return may be variable so that either the cathode or ground may be used as a reference point.

If the present cable does not contain enough wires to permit revising the setup, a jumper may be run from No. 8 of the new eight-prong socket, since in almost all cases the No. 8 prong is for the shell in metal tubes and goes to ground. Similarly, the control grid in tubes with a cap may be "jumpered" over to the analyzer.

One thing to keep in mind is that the numbering of the tube pins will not be the same for all tubes, i.e., the RMA tube-pin numbering system is used for 4, 5, 6, and 7 prong tubes whereas the 8-pin numbering system is used for the new sockets added. As an example in the RMA pin system, pin No. 1 is practically always one side of the filament or heater; while in the 8-pin system the heater is usually No. 2 pin. A detailed description is not given since that is beyond the scope of this article.

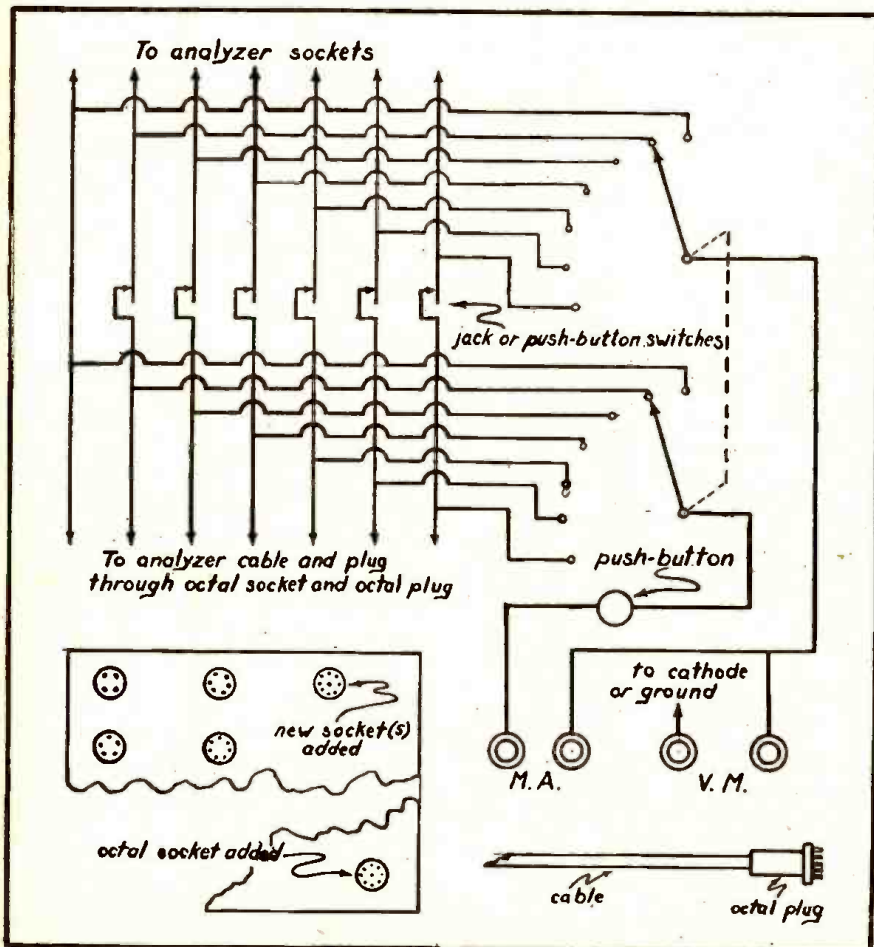

Circuit to be used as a guide in modernizing old-type analyzers to read voltages at 8-prong tube sockets.

## SPRAYBERRY RADIO TRAINING

includes

### FULL EQUIPMENT

Experience Easily Acquired at Home



You Do Practice - Giving Experiments. Many Special Features . . . ALL Designed to Help You Make Fast Progress

SPRAYBERRY Training starts right at the beginning of Radio. You easily learn Television, Frequency Modulation, Signal Tracing, Mobile Radio (Auto-Tank), Aviation Radio, Electronics, Facsimile Radio, Radio Set Repair and Installation work.

Training Prepares You for a Business of Your Own . . . or Good Radio Jobs—Civilian or Military

Today, Radio offers remarkable opportunities to the man who wants to get ahead. My Training will help you win quick promotion in the Army or Navy . . . will fit you for a bright Civilian career. Your Training will not interfere with your present duties. No previous experience is needed.

You Get a Dual-Purpose Radio Set

I supply you with Radio Parts which you use to gain pre-experience in Repair work. These same Parts are used as a Modern Signal Generator and for Signal Tracing, etc. You'll find my Course and Equipment fully described in the catalog offered below. But in addition to this catalog, I am going to send you a valuable new manual.

**YOUR'S FREE! Just Off The Press!**

Big 80-Page Book

"RADIO SERVICE SHORT CUTS"

Don't miss it! It's a rich storehouse of practical tips and information. Tells how Radio break-downs occur . . . how to spot these defects . . . how to correct them quickly and efficiently. If you ACT now, you can get this book FREE along with my descriptive Course Catalog. Use coupon below!

THE SPRAYBERRY COURSE IS SOLD UNDER MONEY-BACK GUARANTEE

RUSH COUPON for BOTH FREE BOOKS

SPRAYBERRY ACADEMY OF RADIO  
 F. L. Sprayberry, President  
 520 L. University Place, N. W.  
 Washington, D. C.  
 Please rush my FREE copies of "HOW TO MAKE MONEY IN RADIO" and valuable 80-page "RADIO SERVICE SHORT CUTS".  
 Name \_\_\_\_\_  
 Address \_\_\_\_\_ State \_\_\_\_\_  
 City \_\_\_\_\_ (Mail in envelope or paste on penny postcard)

**The Book that takes Drudgery out of Mathematics**

Only **50c** postpaid

SOLVES EVERYDAY PROBLEMS — HELPS YOU GET AHEAD IN LIFE

How many times have you lost money because of a mistake in figuring? Do you know how to figure quickly and correctly? Can you figure discounts, interest rates, taxes and all the other calculations you must up with in your daily life?

Are you having trouble qualifying for Army or Navy promotion because you're not up on mathematics? Here is the book that gives you a good background in mathematics; that takes all the irritation and drudgery out of it. You don't need to be scared of mathematics, because here's the subject explained without frills, without useless computations.

Here's the book for men in the armed forces; for business men; technicians and craftsmen, explaining and answering everyday mathematical problems in easy-to-understand words and illustrations.

Yes, it's the key to a simple understanding of mathematics. It's a real home-study course in mathematics for the man who's alert to the importance of mathematics in the world today.

## ELEMENTARY MATHEMATICS

• EASY — SIMPLIFIED — PRACTICAL •

**CONTENTS OF BOOK**

- CHAPTER I. Arithmetic—Addition—Subtraction—Multiplication—Division
- CHAPTER II. Factoring and Cancellation—Fractions—Decimals—Percentage—Ratio—and Proportion.
- CHAPTER III. The Metric System.
- CHAPTER IV. How to Measure Surfaces and Capacity (Geometry).
- CHAPTER V. Powers and Involution—Roots and Evolution.
- CHAPTER VI. Mathematics for the Manual and Technical Craftsman—Thermometer conversions—Graphs or Curve Plotting—LOGARITHMS—Use of the Slide Rule.
- CHAPTER VII. Special Mathematics for the Radio Technician.
- CHAPTER VIII. Commercial Calculations—Interest—Discounts—Short Cut Arithmetic.
- CHAPTER IX. Weights and Measures—Useful Tables.

ONLY **50c** POSTPAID

Send Stamps, Cash or Money Order.  
 Send today for your copy of this indispensable book. It can be carried readily in your pocket. (Size 6 x 9 in.)

## TECHNIFAX

1917 S. State St., RC-1142, Chicago, Ill.

# A SIMPLE AND EFFECTIVE CONDENSER TESTER

By EUGENE BERTIN, JR.

**T**HIS article describes and gives all information necessary for construction of and use of the condenser tester and general purpose power supply shown in Figs. 2 and 3.

This device has been in use for over a year now in the writer's radio service shop and has also been put through its paces in experimental work in the writer's private amateur chemical and radio laboratory. The tester as diagrammed and shown IS IN ITSELF INCOMPLETE AND MUST BE USED IN CONJUNCTION WITH THE MILLIAMMETER OF THE SHOP SET TESTER.

Personally, I have found the method of testing condensers incorporated into this tester to be far better suited to our service requirements than the conventional "resistance method" of testing condensers.

In principle, the tester applies the actual rated D.C. working voltage across the condenser and then shows directly on the milliammeter the amount of current passing through the dielectric (if any).

As the diagram adequately shows, the tester consists of a simple, conventional power supply using a "junk-box" 700-volt power transformer, an 83 rectifier (an 80 will do, although the voltage drop in the 80 is greater), two 16-mf., 450-volt electrolytic filter condensers, a "junk-box" filter choke and a 25,000-ohm, high power wire-wound resistor.

Across this resistor is a voltage divider consisting of seventeen 3500-ohm, 3-watt resistors in series, each junction being brought out to a tap on the seventeen-point switch, SW<sub>5</sub>.

I feel that the connections to the Switches and Terminals are obvious from the diagram and that I need not enter into an involved description of them here. The style of mounting is entirely up to the individual. The writer's is, as plainly evident from the pictures, breadboard style with a tempered

hardboard or masonite panel in front.

On the tester in use at the writer's shop, switches SW<sub>2</sub> and SW<sub>3</sub> are toggles. They should be push-button type. The lower selector switch on the picture is merely the milliammeter range selector. This part need not be incorporated since there is a milliammeter range selector on most Volt-Ohm-Milliammeters and Set Testers in conjunction with which this tester must be used.

## TESTING CONDENSERS WITH PAPER DIELECTRIC

Following is the step by step description of the procedure followed in testing condensers with paper dielectric. The procedure enumerated should be followed in testing all condensers NOT of the electrolytic variety. At first glance, the process may look formidable, but soon the steps will come as automatically as any simple shop procedure, such as testing voltages, etc.

- (1) Connect the two terminals indicated in the diagram to the milliammeter terminals on your set tester just as though you were setting up to measure plate or screen current. (Polarity must be observed.)
- (2) A black test lead with a solderless tip on one end and a black test probe on the other should be provided for the Negative (-) condenser (see diagram).
- (3) A red test lead with a solderless tip on one end and an insulated alligator clip on the other should be provided for the positive (+) condenser (see diagram).
- (4) Turn SW<sub>1</sub> on.
- (5) Assuming that SW<sub>2</sub> and SW<sub>3</sub> are push-button type, they will be open, and SW<sub>4</sub> (toggle) should be open also.
- (6) Set SW<sub>5</sub> for the working voltage of the condenser under test, or, if the exact voltage is not available, to the

next lower voltage (if the unit is built up like the writer's, the positions of SW<sub>5</sub> will run from 20 to 340 volts in steps of 20 volts each. It will be found that 400- and 600-volt condensers will give entirely reliable leakage and short tests on the highest position—No. 17, 340-volts. Even 1000- and 1500-volt condensers can be tested for shorts with practically 100% reliability and for leakage with a slightly lesser degree. It is wise to check such high-voltage condensers by the "resistance method" to make sure.)

- (7) Now clip loose or unsolder one lead of the condenser to be tested.
- (8) Clip the battery clip test lead to this loose end.
- (9) Touch the test prod lead to the other end securely.
- (10) IF AT ALL SUSPICIOUS THAT THE CONDENSER MAY BE SHORTED OR AT LEAST VERY LEAKY, SET THE MILLIAMMETER RANGE SWITCH ON YOUR SET TESTER TO THE 0-200-MA. SCALE OR A HIGHER ONE YET! THIS IS IMPORTANT!

(11) Depress Sw<sub>2</sub>.

## RESULTS:—

- (a) Assuming that the milliammeter is on the 0-200 scale or higher, a good or an open condenser will show no deflection whatever, or, at best, only an almost imperceptible one.
- (b) A shorted or very leaky condenser will show a large current reading.
- (12) If the condenser is shorted or very leaky, discard it without further ado; if not:—
- (13) Turn the milliammeter range selector down to the 0-1 scale, and depress SW<sub>2</sub> again.

## RESULTS:—

- (a) A good condenser will cause the pointer to "flick" up—the greater the capacity the greater the "flick"—AND THEN RETURN ALL THE WAY BACK TO ZERO.
- (b) A leaky condenser will either:
  1. Cause the pointer to raise to a certain point and remain there.
  2. Or else "flick" the meter just like a good condenser BUT THEN NOT RETURN TO ZERO; it will instead show a certain current reading.
- (c) An open condenser will show no deflection whatever.

Now just how leaky should a condenser be before it is discarded? That I leave to the discretion of the individual serviceman. Personally, my policy has always been very strict. I "toss 'em out on the least provocation," because leaky condensers don't have too far to go to become SHORTED condensers. My criterion is: A GOOD PAPER CONDENSER SHOULD PASS NO DIRECT CURRENT THRU ITS DIELECTRIC!!!

Now condensers of small capacity—like .001s and smaller often show such a faint

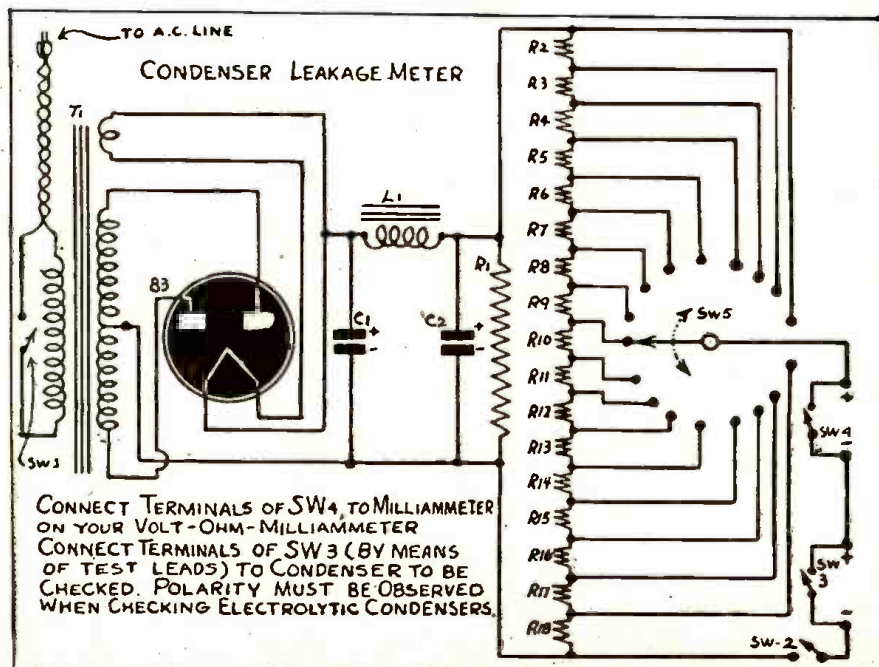

## LOW-RANGE OHMMETER

By CHARLES A. BROOKS

**A**LTHOUGH a new meter may be used, a meter such as the Weston 506 may be used. Many of these meters can be had for little or nothing. They were used to a great extent on battery sets, as "A" battery voltage indicators.

First find the internal resistance of your meter. With a fine pen and India ink mark this value at the Center of the scale. Then cut a few feet of wire (No. 30 to 36) and connect to x-x. Cut off small pieces of wire until scale reads at the one-half-scale mark. Next, measure this piece of wire. Divide the length of the wire by the internal resistance of the meter. This product may then be multiplied by any desired scale reading, to produce the length of wire to be connected to x-x to provide that calibration point.

Be sure to use heavy wire when wiring from the meter to the tip jacks. R1 is not

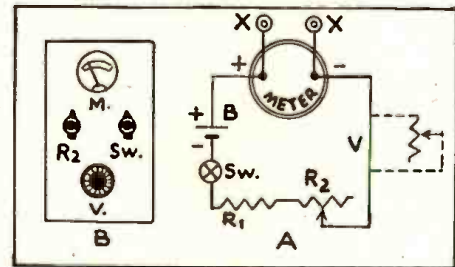

critical. If the internal resistance of your meter is less than 4 ohms, a lower value of R1 is to be used; if more than 4 ohms, use a higher value.

If difficulty is experienced in balancing the meter to zero, a rheostat of ten to twenty ohms may be connected in the circuit (at V) for vernier zero adjustment.

This meter may be calibrated to read from one fourth ohm, to 300 ohms (with a four ohmmeter), without bunching of calibrations. Meters of one ohm resistance will read to 1/32 of an ohm with a good degree of accuracy.

When meters of higher resistance are used, commercial resistors may be used on the high end of the scale.

The style of case and panel arrangement is left to the reader. Mine measures 5"x1 1/2"x6". The panel arrangement is shown in the sketch.

### List of Parts

Two Tip jacks X-X  
One Flashlight cell, B  
One S.P.S.T. switch, S  
One 200 ohm, 1 watt, carbon (for Weston 506) R1  
One 150 ohm rheostat, wire-wound, R2  
One meter (M) of low internal resistance, with shunts or internal resistors removed

### REPLACING THE BH RECTIFIER TUBE

The BH rectifier tube in some of the old-timer radios, can be replaced by changing the socket and using the OZ4 or OZ4G. The voltage and current conditions will nearly always be within the limits of the OZ4, however these operating conditions should be checked to make sure that there will not be an overload on the tube. The large pins are the plates on the BH and No. 2 pin is the cathode. By referring to the OZ4 base diagram you should have no trouble in making the proper socket connections.—*Sylvania News*

"flick" that it's hard to tell whether or not they might be open. The procedure with such condensers is to test them as above to determine whether they are shorted or leaky. I then take the test prod off the one end (leaving the condenser in a charged condition) and short the ends with a piece of rather fine wire. If I hear a tiny discharge, I know the condenser was charged and therefore not open. Here the ohmmeter serves as a good check.

Large paper condensers, like .25s, .5s, 1s, 2s, 3s, etc. make the meter "flick" so much on the 0-1 scale that there is some danger of bending the pointer or even over-heating for an instant the delicate coil in the armature. There are two ways of handling such condensers:

(1) After testing on the high scale for shorts or excessive leakage, test them on say a 0-5, or 0-10 milliamper scale until they are charged, as indicated by the return to zero of the pointer. Then slip the milliammeter range selector down to the 0-1 scale for a finer reading of the leakage (if any).

(2) Or else close the toggle switch SW<sub>1</sub>, thereby shorting out the meter until they've charged; then open SW<sub>1</sub> and read the leakage (if any).

SW<sub>2</sub> is provided as a convenient means of discharging condensers to avoid accidental shock.—You can get some mean ones from a .25 or higher!!! But I have always preferred to discharge them with a screwdriver to see how they "snap". This gives a double-check on the condenser.

**CAUTION: WHEN USING SW<sub>1</sub> TO DISCHARGE THE CONDENSER, BE SURE TO RELEASE PUSHBUTTON SW<sub>2</sub> OR YOU WILL SERIOUSLY DAMAGE THE METER IF ON A LOW SCALE.**

When there are two or more condensers in a block with a common lead or terminal, or with the metal container common, clip the common lead loose, or unsolder the wires from the common terminal or insulate the common can from the chassis; clip the battery clip lead to the common and test the condensers one by one by touching the test prods on the various leads and testing as you would a single section. **ONE SIDE OF A CONDENSER SHOULD ALWAYS BE CLIPPED LOOSE OR UNSOLDERED BEFORE TESTING!**

### TESTING ELECTROLYTIC CONDENSERS

The procedure used in testing electrolytics is much the same as for paper condensers, but interpreting the results is somewhat different.

Steps (1) to (6) inclusive are the same as for paper dielectric condensers.

(7) Now unsolder all wires from the positive lug of the condenser to be tested (if a wet can type), or clip or unsolder one of the wires (if the condenser has wire leads), and clip the red test lead on the positive terminal (Polarity must be observed here).

(8) Touch the test prod to the negative terminal (which is often the chassis, or at least the can).

(9) Set the milliammeter range selector to the 0-200 scale or higher.

(10) Depress SW<sub>2</sub>.

### RESULTS:—

- (a) An open condenser will make no deflection whatever.
- (b) A good condenser should make a noticeable "flick".
- (c) A very leaky or shorted condenser will show a high current reading.

(11) In instance (c) the condenser should, of course, be discarded.

(12) Otherwise, the milliammeter range selector may be dropped to the 0-50 or 0-15 or 0-5 scale (depending upon how much "flick" it made on the 0-200 scale).

(13) Depress SW<sub>2</sub> again.

### RESULTS:—

(a) An open or completely dried out condenser will make no deflection.

(b) Some electrolytics will cause the pointer to rise to a certain point and remain there; i.e., there will be no tendency for the pointer to return to zero. Such condensers are acting as pure resistances and should be discarded.

(c) Good electrolytics will cause the meter to "flick" and then come back toward zero. I HAVE FOUND THAT AS A GENERAL RULE AN ELECTROLYTIC CONDENSER IS O.K. IF IT DOESN'T LEAK MUCH OVER ONE FOURTH AS MANY MILLIAMPERES AS ITS CAPACITY IN MICROFARADS AT OR NEAR ITS WORKING VOLTAGE.

(14) A good check on an electrolytic filter condenser is to charge it up on the tester and then discharge it with a screwdriver after allowing it to stand in charged condition for a few seconds. A good "crack" (spark) should result.—The higher the capacity and working voltage, the louder should be the "crack" and the bigger and brighter the arc.

(15) Low voltage (10-, 25-, and 50-volt) condensers should not be expected to crack on discharging. They should "flick" the meter and come back pretty close to zero.

Care should be exercised not to use too low a meter scale when checking filters. Only rarely can the 0-1 milliamper scale be used, and then only when the charging has been done on a higher scale or with SW<sub>1</sub> closed.

Multi-section electrolytics can be tested just like multi-section paper types. Clip or insulate the common and test the condensers one by one.

**CAUTION:** Usually high and low voltage electrolytics are found in the same set—even in the same can. Don't forget to have the voltage Switch SW<sub>1</sub> at the proper voltage. Once I tested a bunch of electrolytics in a can. There was a 10-mf./450-volt, two 8-mf., 450-volt, and a 25-mf., 25-volt in the same can with a common negative. Well, I tested the filters first and then forgot to drop SW<sub>1</sub> down to position No. 1 (20 volts). The result was that I blew a probably perfectly good cathode condenser and had to replace it out of my own pocket. Too frequent recurrence of such accidents lowers the old income.

The best way of all to get the hang of this instrument is to take a bunch of assorted condensers—papers and wet and dry electrolytics—all working voltages and capacities—good, shorted, and leaky—and make a practice test-run on them. Ten or fifteen minutes of such practice will prove sufficient to give any serviceman with average intelligence the "hang" of this excellent tester.

The tester also serves as a mighty handy source of good D. C. voltage to have around the shop. My men often use it on battery sets to save wear and tear on the B-batteries.

(Continued on page 107)

# OSCILLATOR CIRCUIT TESTER

By HARRY L. POLING

**B**EFORE radio servicing can become very profitable, the stream of repaired radios flowing out of the service shop must be induced to gush along at a fairly rapid rate. Unfortunately there are some common receiver troubles which require so much time to locate that the servicing schedule is slowed down.

Aside from receivers afflicted with "intermittent" troubles, there are few defects that will slow down production like a dead oscillator stage. This trouble usually man-

ages to show up in a rush job during the course of an extremely busy day.

Of course, many oscillator circuit troubles are easily solved, but frequently these circuits will check O.K. with ordinary servicing instruments, yet firmly refuse to do anything which might be construed as oscillation. In these cases quite a lot of time is usually wasted in locating the trouble by trial and error methods.

The instrument described and illustrated here was built to enable more rapid servic-

ing of non-oscillating oscillator circuits. It will indicate whether the circuit is oscillating, and at what frequency. It will measure the resonant frequency and tuning range of a receiver's oscillator circuit, even with the receiver dead. It will supply a substitute oscillator signal so that the remainder of the receiver may be tested and serviced. Also it will indicate whether a suspected oscillator circuit is capable of oscillation and how much amplification is required to produce this happy condition. In addition, this instrument contains a universal substitute oscillator coil which may be temporarily connected into the oscillator stage of most receivers.

## THE CIRCUIT

Briefly the circuit consists of a self-contained oscillator to which circuits under test are coupled and the reaction caused by them is shown on an electron ray indicator tube. An extremely flexible amplifier circuit with variable gain is used to determine the oscillating possibilities of the receiver circuits.

Referring to the schematic it will be seen that the simplest way to describe the circuit is by a step by step description of the circuit conditions resulting from setting the two selector switches to their various positions.

The selector switch marked "TEST" has five positions. In the position marked "oscillation" the two "TEST" tip jacks are connected through a voltage divider to the grid circuit of the 6E5 tube. In this circuit, the eye, which normally closes at around eight volts now functions as a vacuum tube voltmeter in which the eye will close at about fourteen volts.

When the "TEST" selector is set to the "frequency" position, the instrument serves to measure the frequency of signals applied to the "TEST" jacks. The signal coming in is applied to the grid of the 6SK7 resistance-coupled amplifier tube. The selector switch section in the place circuit of this tube delivers the amplified signal to the grid circuit of the 6J5 tube through the small coupling capacity  $C_1$ . As the 6J5 circuit is oscillating, there will be a negative voltage developed across its grid resistor. The 6E5 grid circuit is switched to this point and indicates the voltage developed across the grid resistor. This voltage is greater than the eight volts required to close the eye, so a bias resistor of three thousand ohms is connected in the cathode circuit of the oscillator tube. As the oscillator tube grid resistor is returned directly to the cathode of the tube, the presence of the cathode resistor does not affect the oscillator tube grid voltage, but it does produce a positive potential, (about 7 volts), between the low end of the oscillator grid resistor and ground. This positive voltage is in series with the negative voltage developed across the grid resistor and thus effectively reduces the negative voltage applied to the grid of the 6E5. The value of the bias resistor was chosen so that the eye is normally almost closed, leaving just a narrow angle. This was done so that any slight change either positive or negative in the grid voltage will cause a noticeable change in the shadow angle. Other tubes used as oscillators would require slightly

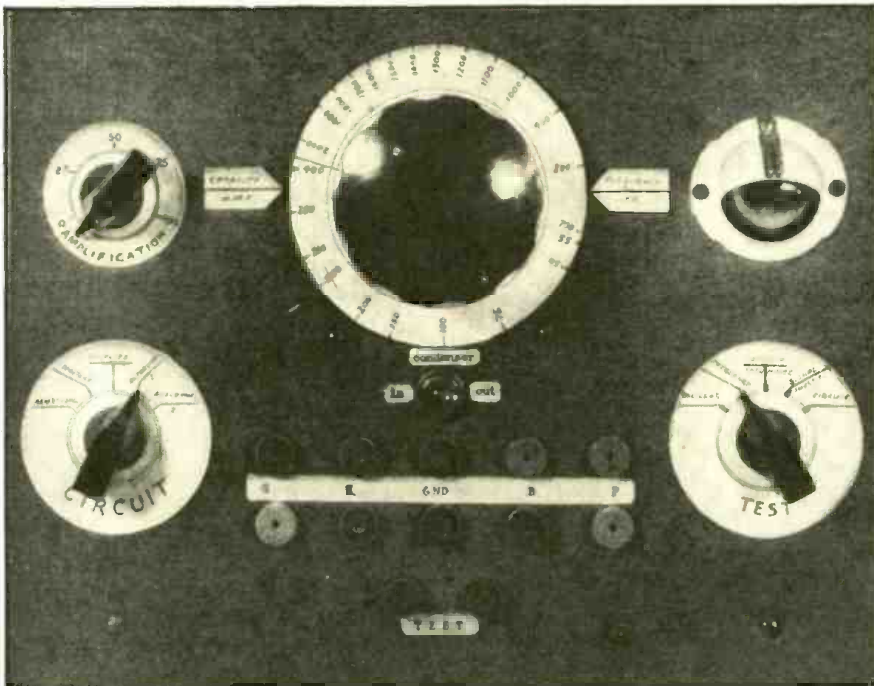

Above—Front view of the oscillator circuit tester.

Below—Back view of the tester.

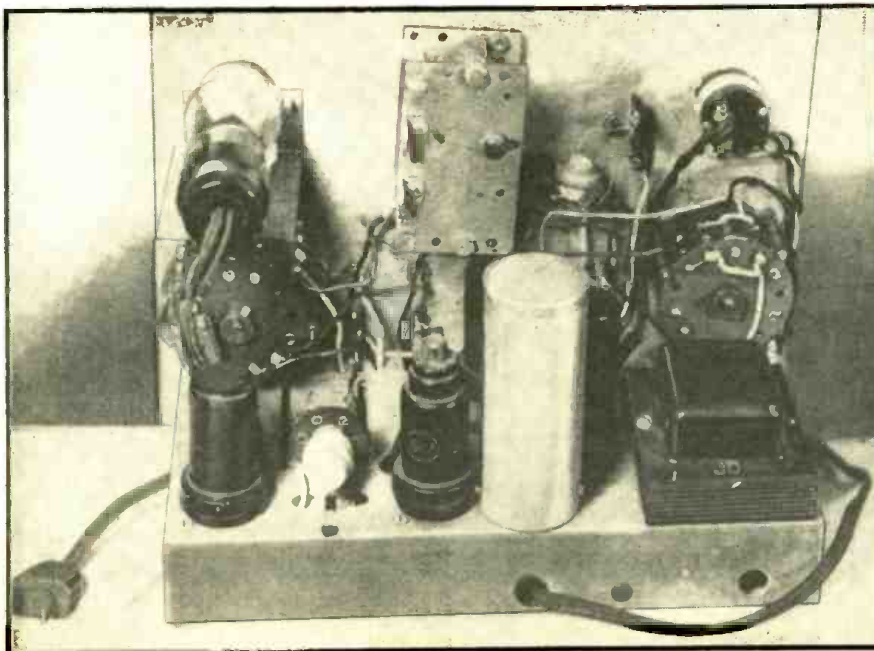

different values of bias resistors to produce this result.

The frequency of the internal oscillator is indicated on the dial of the variable condenser which has been switched into the circuit. When a signal is applied to the "TEST" jacks, its amplified version is applied across the oscillating circuit. When the incoming signal is of the same frequency as the internal oscillator, it will cause an increase in the amount of R.F. current flowing in the grid circuit of the 6J5 and an increase in the grid current. This causes an increase in the voltage developed across the oscillator grid resistor and the eye of the 6E5 will close and usually overlap.

When the "TEST" selector is rotated to "resonance" position, the circuit is much the same as for "frequency" except that the "TEST" jacks are connected directly to the coupling condenser C, and the resistance coupled amplifier is no longer in the circuit. When the test leads are connected across a circuit under test whose frequency is the same as that of the tester, the circuit under test will "load" (or draw power from) the oscillating circuit. This will cause a decrease in the amount of R.F. power circulating in the 6J5 grid circuit and a consequent decrease in the voltage developed across the grid resistor. This

dropping off in grid voltage will cause the eye to open up rather widely when the two circuits are at the same frequency.

When the "TEST" selector is set to the "signal substitution" position, the circuit is the same as for "resonance" except that the test leads are coupled to the internal oscillator through a somewhat larger coupling capacity C2. This larger condenser will cause a slight detuning of the oscillator frequency, but it is necessary in order to permit a reasonably large R.F. signal to be delivered to the circuit under test.

In all of the first four switch positions, the variable condenser is connected so that it is always in the circuit regardless of the position of the condenser toggle switch. The positions of the other selector switch and amplification control have no effect on the circuits so far described, except that the off-on power switch is attached to the amplification control.

The test leads for use with the circuits so far described are simple. One is merely a ground connection for connecting the chassis of the tester to the low side of the circuit under test. This lead is black and has a black sleeve over the alligator clip at the end. The other lead is red and is used for connection across tuned circuits and for the voltmeter test. At the business end, this red lead has a small resistor and

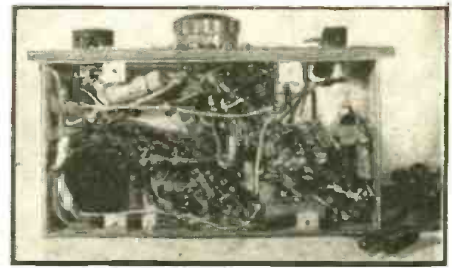

The top view of the tester is shown in the above photograph.

mica condenser connected in parallel.

When the "TEST" selector is turned to the "circuit" position, the tester is set up to measure the ability of an oscillator circuit under test to oscillate. This is done by connecting the circuit under test to an amplifying circuit similar to that used in the oscillator circuit of the receiver under test. A 6K7 tube is used as the amplifier and its amplification is varied by a potentiometer in the screen circuit. A 250 ohm bias resistor maintains a minimum bias on the 6K7. The 6E5 grid circuit is switched to measure voltage developed across the grid resistor and the variable condenser is con-

(Continued on following page)

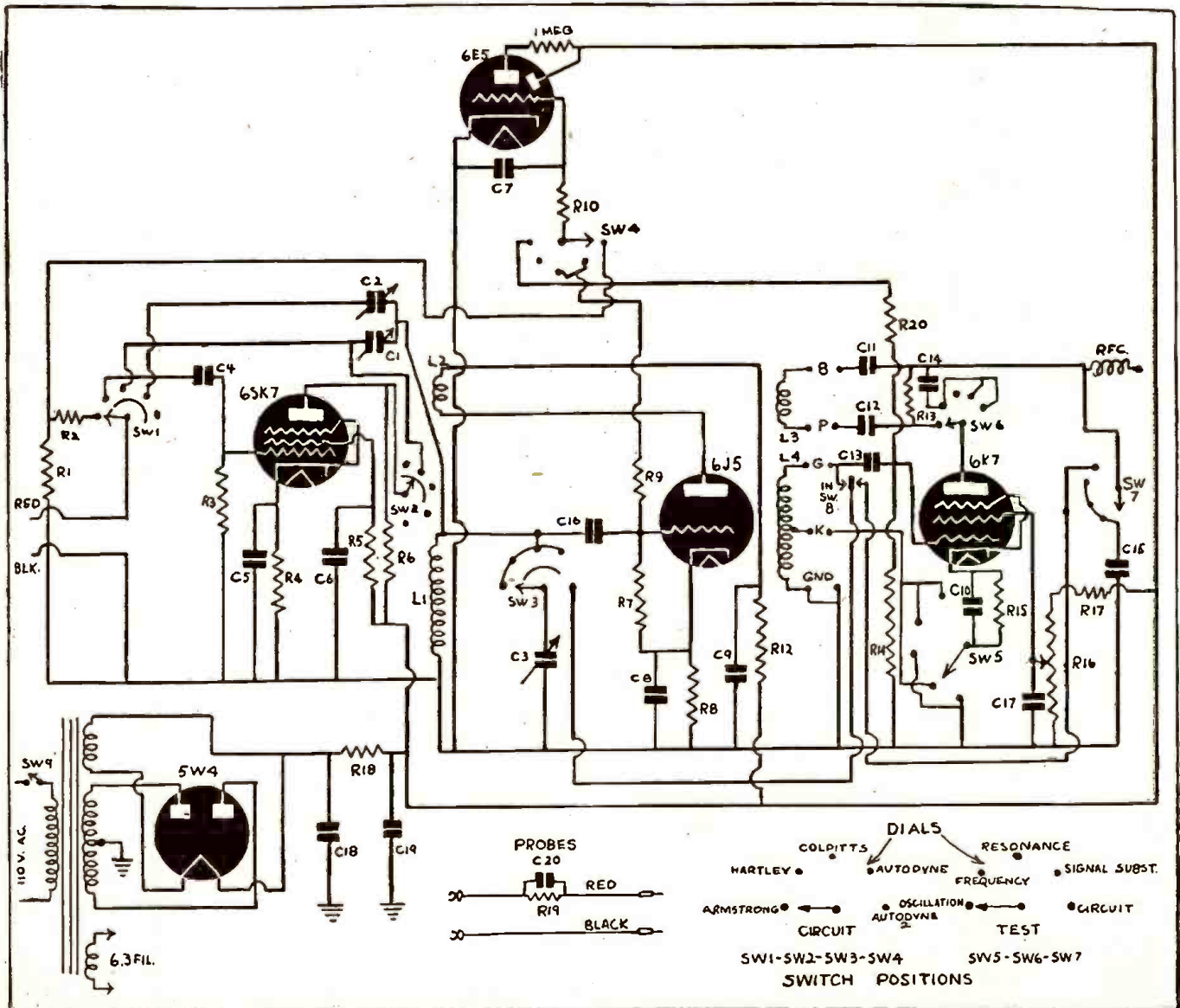



Northern Radio Laboratory  
3927 East Lake Street  
Minneapolis, Minn.  
"We have been using N.U. products since their inception. They have an aggressive merchandising plan we feel all dealers should avail themselves of. After 22 years in the radio business, we find National Union's helps have always been an asset to us."  
A. H. WOLFE

WHERE YOU FIND  
**NATIONAL UNION**  
YOU FIND BETTER  
**RADIO SERVICE**

**PREMIUM**  
*Quality*



*Quality*

**TUBES**



**BATTERIES**



**CONDENSERS**

also *Transmitting tubes, panel lamps, cathode ray tubes, exciter lamps, sound equipment, photo electric cells, sound accessories, dry batteries, flashlight bulbs.*

**NATIONAL UNION invites . . .**

All radio service dealers to enjoy the benefits of the N. U. Shop Equipment Plan. The latest in tube testers and test equipment are available to you . . .

More than 60,000 completed deals prove the success of this plan. Investigate now.

Ask Your N. U. Distributor or Write



**NATIONAL UNION**  
**RADIO Corp.**  
57 STATE ST., NEWARK, N. J.

**OSCILLATOR CIRCUIT TESTER**

*(Continued from previous page)*

nected through its toggle switch to the tip jack marked "G". In making "circuit" tests, the eye is normally wide open instead of nearly closed as in the previous operations.

The "TEST" selector is left in the "circuit" position when making circuit tests and the control functions are carried out by means of the "CIRCUIT" selector and the "AMPLIFICATION" control. The most common types of oscillator circuits have been classified according to their common names and the "CIRCUIT" selector switch is set to duplicate as nearly as possible the normal circuit conditions for the operation of these circuits. Tip jacks provide connection to the various circuit elements.

It will be noticed in the schematic that the tip jacks for plate and B+ to the 6K7 tube have been made through condensers, and a plate resistor is used to provide R.F. voltage drop. This type of circuit was used to prevent plate current in the tester from flowing into the circuit under test.

When the "CIRCUIT" selector is set to "Armstrong" position, the cathode of the 6K7 is switched to ground instead of the cathode tip jack. The R.F. by-pass condenser in the plate circuit is connected to ground and the bypassing condenser across the plate resistor is opened. This permits the tester to function as the amplifier section of a conventional Armstrong oscillator circuit, except that the tickler coil is capacity coupled.

In the "Hartley" position of the "CIRCUIT" selector, the cathode of the 6K7 is connected to the cathode tip jack, the plate resistor is shunted by the shorting condenser and the plate by-pass is connected to ground. This places the plate circuit at ground potential so far as R.F. is concerned. When the coil or circuit under test is connected to the proper tip jacks, the cathode circuit is completed to ground through the tap on the oscillator coil.

In the "Colpitts" position the "CIRCUIT" selector connects the cathode to ground, closes the R.F. by-pass switch and opens the condenser shunting the plate resistor.

When the "CIRCUIT" selector is turned to "Autodyne-1" position, the cathode of the 6K7 is connected to the cathode tip jack, the R.F. by-pass condenser in the plate circuit is opened and the shunting condenser across the plate resistor is closed. When the circuit to be tested is connected to the proper tip jacks, the R.F. choke in the plate circuit will offer sufficient impedance to R.F. currents to cause them to flow to ground through the circuit under test.

In "Autodyne-2" position, the same circuit is used except that when the tuning condenser toggle switch is "out," the tuning condenser is connected in parallel with the plate coupling coil of the circuit under test.

The test leads used in making "circuit" tests consist of five short leads with phone tips at one end and alligator clips at the other. The substitute oscillator coil consists of a Hartley type coil with a tickler winding added. This permits the coil to be substituted into practically any type of oscillator circuit.

The power supply is conventional except that it uses a 10,000-ohm ten-watt resistor in place of a filter choke. This is entirely satisfactory as not much filtering is required and the low current drain of the tester does not produce a large voltage drop across the resistor.

**CONSTRUCTION**

This instrument was constructed mainly with parts salvaged from a dismantled

small receiver and an obsolete tube tester. All parts except the power transformer and tube sockets were removed from the receiver chassis. An 8 1/2 x 10 in. plywood panel was drilled and bolted to the chassis.

The rotary selector switches which were salvaged from the old tube tester were very economically constructed (from the manufacturer's viewpoint). At any position of the switch where no connection was needed, there just wasn't any switch contact either! However, by disassembling three switches, it was found possible to assemble one three-deck and one four-deck switch with a sufficient number of successive contacts.

The 6E5 indicator tube was used in preference to the other types because of its greater sensitivity.

The wiring presented no particular problems, only a little care to be certain that the selector switches were properly connected. All grid, plate and R.F. wires were kept as far away from one another and from chassis as possible to reduce distributed capacity. No shielding, either of wiring or of component parts, was used in this tester because there is little opportunity for undesirable feed-back, and shielding would only have increased the distributed capacity of the unit. This would have caused reduced tuning range in the tester and increased loading of the circuits under test.

The two variable coupling condensers were trimmer condensers taken from the junked receiver. Any very small capacity trimmers might well be used. For convenience, the top row of five tip jacks are connected to circuits of the 6K7 and the corresponding tip jacks in the lower row connect to the proper terminals of the substitute oscillator coil. The jacks marked "ground" in both rows are connected together and to the chassis. This provides the extra ground connection required when testing some types of oscillator circuits.

The oscillator coil used in the internal oscillating circuit was the one originally used in the receiver. As the receiver's tuning range was 550 kc. to 1600 kc. and the I.F. was 450 kc., the oscillator normally operated at frequencies between 1000 kc. and 2050 kc. when tuned with a 350 mmf. condenser. The tuning range was increased somewhat by removing ten turns from the grid coil and then tuning the coil with a condenser having a larger maximum capacity (415 mmf.). Also the low frequency end was extended somewhat by the omission of the padding condenser. With this arrangement, it was found possible to tune over a range of 700 kc. to 2000 kc. in spite of the high distributed capacity of the wiring and switches. This range was found sufficient to check the operation of nearly any broadcast oscillator frequency.

Selecting the correct capacity for the coupling condenser incorporated in the red test lead required some experimenting. If the condenser were made too large, it would allow the test lead capacity to seriously detune the circuit under test. If too small, it would not permit sufficient coupling for the circuit resonance test. The value finally used was 25 mmf. A 1/2 megohm resistor is connected in parallel with the condenser to provide a path for the voltmeter measurements.

To conform with other shop equipment, the panel of this tester is finished in grey crackle enamel and red knobs are used. The dial plates for the knobs were made from white cardboard and the lettering done with heavy pencil. The lettering on the marker strips was made with the typewriter. The dial scales and marker strips are glued in place with speaker cement. The escutcheon plate for the magic eye was enameled white with red trim to match the appearance of the knob plates.



In the case of the main tuning dial, the knob was removed and a white cardboard disc cut the same size as the dial and glued into position over the old scale. When the cement had set, the dial was reassembled and installed on the condenser shaft. The capacity scale on the dial was obtained by measurement with a bridge of known accuracy. The "TEST" selector switch was set to "circuit" position and the condenser toggle switch thrown to "in" position. The capacity bridge was connected between the upper "G" tip jack and ground. The capacity was measured at various dial settings and marked on the dial scale. The ground end of the 6K7 grid resistor was unsoldered during this measurement to prevent loading.

The frequency scale calibrations were obtained by turning the tester on and setting the "TEST" selector to "frequency" position. Coupling condenser  $C_1$  should be set at about  $\frac{1}{4}$  full capacity. The oscillator in the tester is then picked up on a broadcast receiver with an accurately calibrated dial. The receiver was tuned to a certain frequency, say 1200 kc., and the dial on the tester was rotated until a swishing noise was heard in the receiver, indicating that the unmodulated wave from the tester was being picked up. As each desired calibration point was located, its position was marked on the dial scale.

To protect the lettering from dirt and damage, all the cardboard scales were given a protective covering after the lettering was completed. This covering consisted of transparent service cement thinned with acetone until it flowed freely. The dials and marker strips were given several coats of this with a soft brush. The finished appearance was that of cardboard covered with celluloid.

The substitute oscillator coil consists of a Hartley type replacement oscillator coil with a 25-turn tickler coil wound at the ground end of the grid coil. The tickler coil should be spaced about  $\frac{1}{2}$  inch from the grid coil. Which tickler coil lead to connect to the "B" and to "P" jacks may best be determined by experiment. If this coil is constructed last, the proper connections may easily be determined by connecting the two rows of five tip jacks together with jumpers and testing as an "Armstrong" coil. With one tickler connection, the circuit will oscillate. With the leads reversed, it will not oscillate.

## ADJUSTMENT

The first adjustment, that of  $C_1$ , requires the use of a receiver which is in operating condition, but not turned on. Set the dial of this receiver to a point about the middle of the broadcast band. Set the "TEST" selector to "resonance." Connect the black test lead to the frame of the receiver's tuning condenser. Connect the red lead to the stator plates of the oscillator tuning condenser. Turn the tester on and set condenser  $C_1$  to full capacity. Rotate the dial of the tester through its range until the eye in the tester suddenly opens up, indicating that resonance has been reached. Then slowly decrease the capacity of  $C_1$  while rocking the tuning dial back and forth until the least a capacity that will just permit a recognizable opening of the eye is found. This will be the maximum trimmer capacity that can be used without seriously detuning the internal oscillator circuit. If the trimmer has to be opened all the way up, it will be best to use a smaller trimmer.

The second adjustment, that of  $C_2$ , is made by tuning in a rather weak signal or station on a good receiver and then shunting the oscillator section of the receiver's tuning condenser with a .1 mfd. condenser to stop oscillation. The tester is turned on and the "TEST" selector is turned to "signal substitution" position. The black lead is con-

nected to the frame of the receiver's tuning condenser and the red lead is clipped onto the stator plates of the converter section of the tuning condenser. The trimmer is set to full capacity. The dial on the tester is then rotated until the signal or station is again heard on the receiver, indicating that the tester is now emitting a signal of the same frequency as that which had been supplied by the receiver's own oscillator. Return the receiver dial slightly to compensate for the slight mistuning caused by the presence of the test prod. Then slowly reduce the capacity of the coupling condenser while rocking the dial of the tester until the lowest usable capacity of the coupling condenser is found which will permit the receiver to operate.

Tests should be made upon several good oscillator circuits in order to determine the normal setting of the amplification control required to produce oscillation in a good circuit.

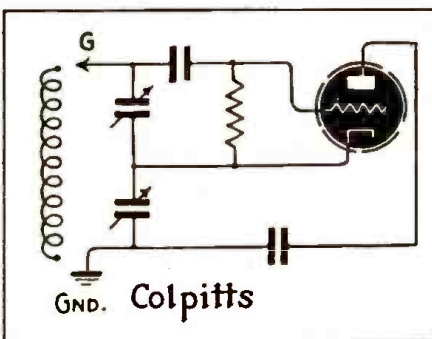
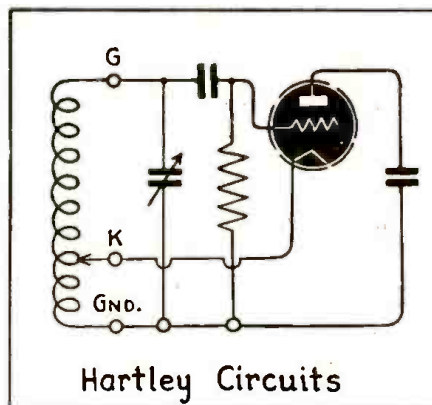
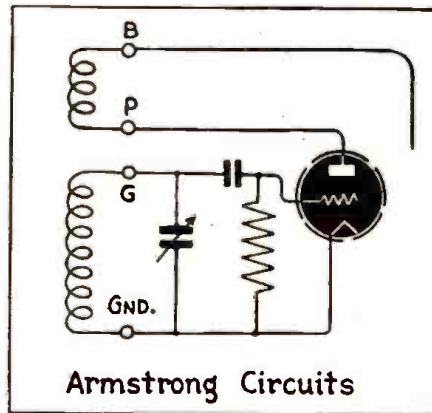

The three most commonly used oscillator circuits in basic form—the Armstrong, the Hartley, and the Colpitts. The tester connections correspond to those shown herewith.

## OPERATION

The relative location of the selector switch positions used on this instrument are the result of an effort to arrange them in the logical successive order in which they

would be used. When any of the first four functions indicated on the "TEST" selector are in use, the tip jacks marked "TEST" are used. In these positions, the settings of the "CIRCUIT" selector and "AMPLIFICATION" control are immaterial as these are in the circuit only when the "TEST" selector is in "resonance" position. (It is necessary to turn the tester on by means of the switch attached to the "amplification control.")

**Oscillation Test**—Eye normally open. One of the first tests to be made upon a suspected oscillator is to check the bias voltage developed across its grid leak while the receiver is turned on. Connect the black test lead to the B—, or to the chassis, depending upon the type of circuit under test. Connect the red lead to the "high" side of the oscillator grid leak. The eye will close with an applied negative voltage of about fourteen, which is about the average value encountered. Any deflection from three quarters closed to overlapping may be considered normal. No indication on the eye means that the oscillator is not operating. By leaving the tester connected and adjusting the tuning dial of the receiver, the intensity of oscillation may be checked at different points in the tuning range. Practically all oscillator circuits use a grid leak and their bias voltage may be tested. The principal exceptions are circuits using autodyne converter stages in which no grid leak is used. This circuit is not intended to be an extremely accurate vacuum tube voltmeter, its purpose being to provide a fairly good estimate of the voltage present.

**Frequency Measurement**—Eye normally almost closed. If the oscillation test has shown the oscillator to be working, or if the circuit under test is one which does not incorporate a grid leak, the next step is to measure the frequency. Connect the black lead to chassis or to tuning condenser frame. Connect the red lead to the stator plates of the oscillator tuning condenser. Turn the dial on the tester through its range until the eye suddenly closes. The frequency of oscillation may be read directly on the tester dial. By measuring the frequency first at one end of the receiver's dial and then at the other, the oscillator's tuning range may easily be determined. The presence of the red lead on the oscillator tuning condenser will cause an error of about 30 kc. at the high frequency end of the oscillator's tuning range, but this will not materially affect the accuracy.

**Circuit Resonance**—Eye normally almost closed. If the oscillator circuit is definitely not oscillating, one of the most important tests that can be made upon it is to determine whether the tuned circuit is still capable of being tuned. This is very difficult to determine with ordinary instruments. Connect the black test lead to the frame of the tuning condenser. Attach the red lead to the stator plates of the tuning condenser. The frequency dial of the tester is turned through its range. If the circuit under test is resonant to any frequency within the tuning range of the tester, the eye will open noticeably when the resonant point is reached. This test is made with the receiver turned off.

If no resonant point is located, the tuned circuit should be inspected for open or shorted coil, shorted tuning condenser or broken wires. Also check for open padding-condenser. By measuring the resonant frequency at both ends of the receiver's dial, the oscillator tuning range may be determined.

The degree of opening of the eye will indicate roughly the "Q" of the circuit under test. It will be normal for a circuit to show a wider shadow angle at the high frequency end of the range because the tester is capacity-coupled and the reactance of the coupling condenser is less at the higher frequencies.

As in the previous test, the reading will be off approximately 30 kc. at the high end of the tuning range. The tester may also be used to determine the resonant frequency of

(Continued on following page)

## OSCILLATOR CIRCUIT TESTER

(Continued from previous page)

any other tuned circuit within its range. This includes broadcast antenna and R.F. circuits, over part of their tuning range.

**Signal Substitution**—Sometimes, when making estimates or for other reasons, it becomes necessary to determine whether a receiver would operate if its oscillator were working. This test is made with the receiver on, setting its dial for the frequency of a desired signal or station, and connecting a signal generator or antenna to the antenna terminals. Connect the black clip to ground. (In the case of an a.c.-d.c. set, to the "floating" ground). Connect the red test lead to the grid of the converter tube. Set the dial on the tester to a frequency equal to the frequency of the desired signal plus the I. F. If there are no other troubles present in the receiver, the desired station or signal should be heard. It may be necessary to slightly readjust both the receiver dial and the dial of the tester in order to obtain maximum volume.

It should be pointed out here that the received signal may not have normal volume under these conditions. This is due to a slight amount of detuning and to the fact that the coupling inside the tester must be kept rather low to prevent serious mistuning. This results in a rather low R. F. output.

When any of the described tests are made upon circuits employing "permeability-tuning," the tests should be made at the center or low end of the tuning range. These circuits have more inductance and less capacity than conventional tuning circuits and a small amount of capacity in the test leads will cause a far greater amount of detuning than it would in an ordinary condenser tuned circuit.

**Circuit Test**—Eye normally open. If the oscillator circuit has demonstrated through the previous tests that it is not oscillating and that its tuning circuit is capable of tuning over the required range, the next step will be to test its feed-back circuits. This is accomplished by connecting the circuit under test to an amplifying circuit which will show how much amplification is required to make the circuit oscillate. This test is made with the receiver turned off. The "TEST" selector is turned to "circuit" position and left there. The "TEST" tip jacks are not used. The circuit under test is connected to the appropriate ones of the upper row of five tip jacks. If the test is to be conducted upon a complete circuit, the condenser toggle switch is thrown to the "out" position. If a coil is to be tested alone, the condenser switch is thrown to "in" position, and the capacity calibration on the dial will indicate how much capacity is in parallel with the coil.

The amplifier tip jacks are connected to the circuit under test as shown in the diagrams illustrating the connections for each type of circuit. The receiver should be turned off while this test is being made. After the tip jacks have been properly connected and the "CIRCUIT" selector set to correspond to the type of circuit under test, the "AMPLIFICATION" control is slowly turned from the zero toward the full position. As the amplification is increased to the point where oscillation begins, the eye will suddenly flicker and close slightly. Increasing the amplification will increase the intensity of oscillation and cause the eye to close further, but the important point is that at which the circuit just begins to go into oscillation. If the oscillation begins at a normal setting, the circuit under test may be considered O. K. The frequency will be that of the circuit under test.

If the amplification control has to be turned very high in order to obtain oscillation, it means that something is increasing the resistance of the circuit or is reducing the effective feed-back. The feed-back coil, if one is used may have moved from its original position. Or, electrolysis may have set in inside the feed-back coil causing shorted turns or resistance in series with the winding. The coils may have absorbed moisture or there may be poor insulation in the coil form or tuning condenser.

If the circuit will not oscillate at any setting of the "AMPLIFICATION" control, check the troubles listed above and also look for opens and shorts in the feed-back coil, grounded cathode in Hartley type circuits, open or shorted by-pass condensers. Also check the capacity of the grid coupling con-

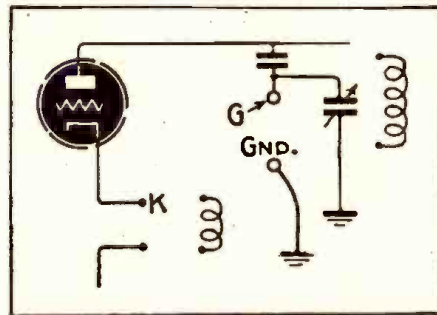
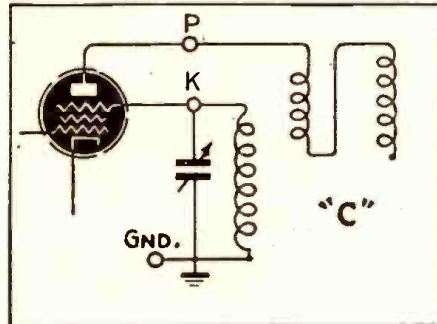
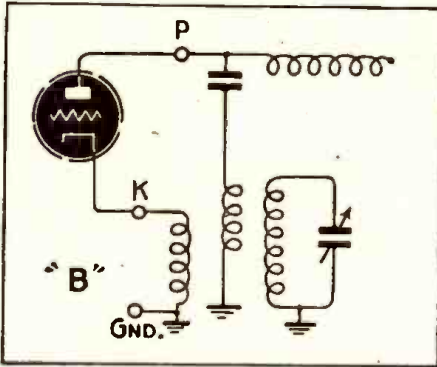
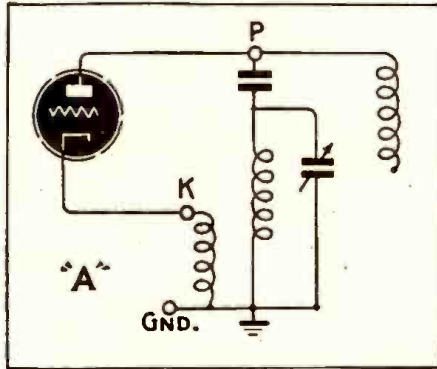

Autodyne circuits, of various forms as used in old-type receivers, with tester connections shown.

denser between the oscillator grid and the tuned circuit.

In the representative circuits shown, the proper connections for the test leads are indicated by circles on the schematic and the letter near the circle indicates the tip jack which is to be connected to that part of the circuit. The examples shown here do not, of course, cover all the possible types of oscillator circuits that might be encountered; their main purpose is to demonstrate the proper connections. Once the connections and operation are understood, the operator will be able to apply the proper connection to nearly any type circuit.

When a Colpitts oscillator coil is tested

alone, the condenser toggle switch is thrown to "out" position and two external fixed condensers must be connected across the coil. The capacity of these condensers may be from 250 to 500 mmf. each and their midpoint is connected to the ground tip jack.

**Autodyne Circuits**—These are circuits in which a single screen-grid tube performs the functions of both oscillator and converter. There seem to be three common types of these circuits.

The "CIRCUIT" selector is used in "Autodyne-1" for all these tests. The condenser toggle switch is turned to "in" position. In testing autodyne circuits, the bias resistor should be located and shorted out with a jumper wire. "Autodyne-2" position is used only when testing coils for circuit (a).

**Oscillator Coil Substitution**—When substituting the universal oscillator coil in the tester for the one in the receiver, it is necessary to disconnect the coil from the receiver wiring. The substitute coil is connected into the receiver circuits by means of the same test leads used for making circuit tests. The setting of the tester controls has no effect on the substitute oscillator circuit. The diagrams shown in the right-hand column indicate the connections for the different types of circuits. It is important to note that there may be some mistuning in the receiver circuits due to a difference in inductance and distributed capacity between the substitute coil and the original.

When the oscillator circuit defects are simple, there is no advantage in using this tester, but if the trouble does not yield to the simple tests, the time saved on very few jobs will pay for the small cost of constructing this instrument.

### PARTS LIST

#### CONDENSERS

- C1, C2—(See text)
- C3—Single Gang 415 mmf.
- C4, C13, C16—0001 Mica
- C5, C6, C7, C8, C9, C10—.01 Tubular 600 V.
- C11, C12—.001 Mica
- C14, C15—.05 Tubular 600 V.
- C17—.1 Tubular 600 V.
- C18, C19—8.8 mf.—450 V.
- C20—(See text)

#### RESISTORS

- R1, R2, R11—1 megohm, ½ watt
- R6, R7, R13—50,000 ohm, ½ watt
- R4, R15—250 ohm, ½ watt
- R3, R9, R20, R19—.5 megohm, ½ watt
- R12—25,000 ohm, 1 watt
- R16—100,000 ohm
- R14, R17—.1 megohm, ½ watt
- R18—10,000 ohm, 10 watt

#### MISCELLANEOUS

- SW1, SW2, SW3, SW4—4-deck, 5-position rotary-switch
- SW5, SW6, SW7—3-deck, 5-position rotary-switch
- L1, L2—Internal oscillator coil (see text)
- L3, L4—Substitute oscillator coil (see text)
- SW8—S.P.D.T. toggle-switch
- SW9—Off-On switch

## REDUCING DISTORTION DUE TO GRID EMISSION

The effects of grid emission are to some extent minimized by the employment of automatic or self-bias in which grid bias is derived from a resistance in the cathode or filament return. An increase in plate current tends to increase the effective negative bias applied to the grid, thus opposing the cumulative effects of the positive voltage caused by grid emission.

The presence of grid emission is usually indicated by distortion, increase in hum, and excessive plate current. It is sometimes difficult to detect the presence of excessive plate current unless the meter is permanently in the circuit during tests, as the switching-off of the tube may allow it to cool sufficiently to restore normal operation. For this same reason grid emission cannot be detected on tube checkers.

In performing tests to determine grid emission the receiver should be thoroughly heated, not by applying excessive line voltage which might damage condensers and other parts, but by placing a box over the chassis so that ventilation is cut off.

A milliammeter, which we all have, permanently connected in the plate circuit will show a rise in current after the receiver is sufficiently heated if grid emission is present.

—Sylvania News.

# NEW RCA LABORATORIES DEDICATED

**T**HE new RCA Laboratories, built by the Radio Corporation of America, at Princeton, New Jersey, were dedicated September 27 to serve the country and its fighting forces in war, and to help build a stronger nation through scientific research. This most modern center of radio and electronic research stands as a monument to a new age in science.

Lieut. Gen. James G. Harbord, chairman of the board of Radio Corporation of America, presided and introduced the speakers: Major General Dawson Olmstead, Chief Signal Officer of the Army; Col. David Sarnoff, U. S. Army Signal Corps, and Otto S. Schairer, vice-president in charge of RCA Laboratories.

"RCA Laboratories assembles under one roof kindred activities which have hitherto been performed by individuals widely separated by time and space," said General Harbord. "The Laboratories give our future scientific work the advantage of collective effort."

Colonel David Sarnoff said that while the war's decision ultimately will be made on the battlefield, the fighting men who have the greatest resources of science, engineering and production in back of them will be the victors.

"Our country is fortunate too that the officers and men in its military and naval establishments have a progressive attitude towards scientific research," said Colonel Sarnoff. "They realize its possibilities, not only as a factor in war, but also in peace. Indeed, the scientists in the Laboratories of the Army and Navy and other government departments themselves have made scientific contributions from which our country has benefited greatly."

"Of all the fields which American men of science have cultivated for peace, and now harvest for war, *radio* is in the first rank of importance. Speed of communication is the essence of modern warfare. Aviation, which has so radically revolutionized military and naval strategy, is particularly dependent upon the countless services of radio."

Colonel Sarnoff said that it is particularly fortunate that during the period prior to America's entry into the war, the Radio Corporation of America had built up its research organization, and that RCA scientists and engineers gained experience along lines that are now of vital military importance.

"A research laboratory consists not so much of buildings and facilities as it does of research men and research leadership," continued Colonel Sarnoff. "The staff of these laboratories is as fine a group of radio scientists as exists anywhere in the world. They have produced outstanding developments in new electronic devices, in television, in ultra-short waves, in acoustics, and in many other branches of radio research. The skills which they developed before the war are now finding direct use in important military applications."

Otto S. Schairer in his dedicatory address declared that RCA Laboratories and its enrollment of men, buildings and equipment stand enlisted in the cause of war. "When we leave here today, the gates will be closed to all except war workers. These structures will be as much a part of the nation's armament as are its arsenals and forts. The men who work here will be as much members of its armed forces as if they were in

(Continued on page 107)

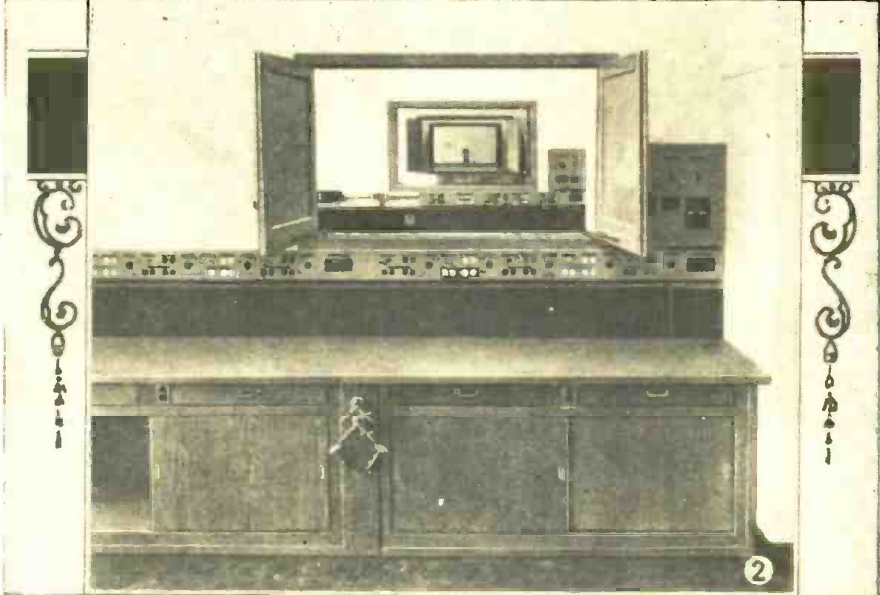
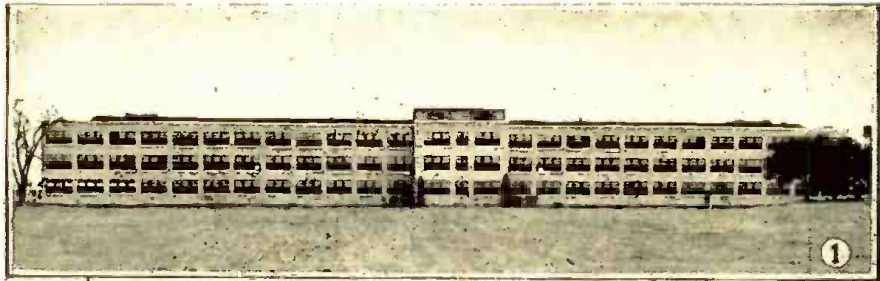

No. 1—RCA Laboratories, a new center of Radio Research and pioneering, at Princeton, N. J. No. 2—In the new RCA Laboratories the bays of the Optic Laboratory are ingeniously connected by door-like windows in the walls, making possible long focuses through the rooms. Note the convenient electric service outlets on the panels atop the work benches, and the spigots for air, gas, water, hydrogen and oxygen supply, on the front of the bench. No. 3—Dr. Harold Willis Dodds, President, Princeton University; Colonel David Sarnoff, U. S. Army Signal Corps; Major General Dawson Olmstead, Chief Signal Officer of the Army, and Lieutenant General James G. Harbord, U. S. Army (retired), and Chairman of the Board of the Radio Corporation of America, at the dedication of the RCA Laboratories, September 27, 1942, at Princeton, N. J.

# RADIO MEN—

**VITAL** need to enlist approximately 100,000 skilled mechanics and technicians immediately in the Signal Corps, radio operators in the Army Air Forces, was recently announced by the War Department.

Keeping pace with the mounting flow of war materiel from the industrial reservoir of the nation, these specialists are needed *now* to keep equipment in operating order.

Army Training Schools are already teaching thousands of men this kind of work, and later in the year their rate of output should be sufficient to keep pace with the need.

To be eligible, men must be between the ages of 18 and 44, citizens of the United States and physically qualified according to general standards for military service. They will enlist as privates, but noncommissioned officer or technician ratings are often given men doing jobs of this sort. Skilled men are needed, and promotion should be rapid with commensurate increases in pay. Whereas a private receives \$50 a month, a master sergeant, the highest noncommissioned grade, receives \$138, to which certain allowances may be added. In considering these amounts, it should be remembered that the Army pays all a man's expenses—food, clothing, shelter and medical care.

To make sure that industry's production program is not upset, all men who wish to enlist as mechanics and technicians now

must be cleared by their local Selective Service Board before acceptance by the Army.

This recruiting program offers trained men the opportunity to qualify as maintenance experts. The Signal Corps wants men whose experience qualifies them as telephone and telegraph cable splicers, telephone and telegraph installer-repairmen, radio operators, telegraphic printer operators, telegraphic printer installer-repairmen, and telephone and telegraph wire chiefs.

While the type of work these men will do should be familiar to them already, the machines and equipment used by the Army offer new opportunities for valuable experience. All three of these branches of the Army are equipped with the most modern, most highly developed machines and devices in the world. Some of the equipment is secret. The man who qualifies as an expert in any of these jobs will have learned much that will be helpful in postwar industry.

The Signal Corps operates the Army's highly specialized communications system, and furnishes equipment to other branches of the Army. The "walkie-talkie" radio pack-sets, which provide two-way communication between infantry in advanced positions and supporting columns, are a Signal Corps development.

**Enlistment Plan.** All men who apply for enlistment will be examined carefully upon

their experience and qualifications.

The Signal Corps will accept a recognized radio or telegraph license or membership in either the Radio Manufacturers Service or Radio Servicemen of America from applicants who desire to become radio operators or mechanics. The Corps will also approve men who are actively engaged in radio service work or who are graduates of a recognized radio school. Qualifications for the other tasks specified may be evidenced by a letter from a commercial communications company stating that the individual has had experience in one or more of these specialties.

Once the qualifications of an applicant are satisfactorily determined, he will be given a thorough physical examination. If no disability is discovered, he will be sworn in immediately as a *private* in the Army of the United States.

All recruits will be sent to a Reception Center for the same kind of "processing" which every man receives when he enters the Army. This is a matter of a few days at most. From the Reception Center, Signal Corps men will be sent to the nearest Signal Corps Replacement Training Center. Here they will begin their real military training and also learn the maintenance jobs for which the Army so sorely needs them. By putting their civilian skills in uniform, these men will fight with the tools they've always worked with.

## RADIO MEN CALLED BY NAVY

**A**MONG the most urgent needs of new officer personnel in the United States Navy is for professional technicians in engineering fields, the Director of Naval Officer Procurement, Chicago, has announced.

Perhaps first on the list are graduate electrical engineers, those mainly between 21 and 50 years who have followed electrical engineering since their graduation, and who have a knowledge of ultra-high frequencies, electronics and television. Those more familiar with power engineering likewise may find a place in the Navy which is interested in these men in ages up to 50 years. Electrical engineers are needed especially in the Navy's fields of radio and detection devices. Men with radio or communication engineering degrees may qualify for officers' com-

missions as well. Waivers for minor physical defects often are obtainable.

A Petty Officer rating is offered to men with sufficient experience in radio to instruct classes in Radio Theory, Practical Operation, Code, or Maintenance.

The Navy has schools in several parts of the country to instruct enlisted men in radio, and it is for these schools that instructors are needed. The men that are selected will go through a refresher course at the Naval Schools, where they will be instructed in the use of radio equipment used by the Navy.

In some cases men with B.S. degrees in other engineering subjects and who have had experience in radio and electrical work

may qualify for officer assignments in radio or electrical lines. Usually, however, degrees in engineering other than electrical tend to fit the applicant for other duty. For instance Navy activities in ordnance, construction, and ship operation use mechanical, civil, and chemical engineers. Here again physical waivers often are possible and the age range is usually between 30 and 45 years or beyond those two limits in some cases.

Another special officer procurement program under way is for college teachers of physics, or chemical, diesel, electrical, mechanical, and radio engineering at Naval Reserve Midshipman Schools. Private school and junior college teachers and others qualified to teach those subjects in colleges are also being sought.

### "WALKIE-TALKIE"

Taking a tip from the London policemen who several years ago wore tiny radio transmitters in their hats, the United States Signal Corps is now equipping its men with one-watt "broadcasting stations." Parachute troops and riflemen equipped with five-pound sets are now able to carry on conversations with their comrades two miles away. Police patrol cars have their counterpart in armored trucks and other motorized units which have been equipped with radio transmitters to receive and broadcast "on-the-spot" military intelligence, time signals and weather reports.—*New York Times*.

(The time is not far off—in connection with the above—when every soldier will be equipped with a ½-lb. pocket 2-way radio.—*Editor*)

### RADIOMEN, LISTEN!

Radio-Craft has been requested by several branches of the United States Government to send out a call for radio men, located in different parts of the United States, who might be available for government radio work.

Radio men who have not previously registered with Radio-Craft and who are citizens of the United States will kindly submit name, address, classification of their type of work briefly, in a letter or postcard.

Your communication will be transmitted to the various branches of the government who can make use of your abilities.

**THIS CALL IS MOST URGENT.** You have an excellent chance to do worth-while work for your country now. As a rule age does not make much difference. Please do not neglect this. Is it your patriotic duty to heed this call.

Mail your letters or postcard to:

RADIO-CRAFT Emergency Aid Bureau  
25 West Broadway,  
New York, N. Y.

### AMATEURS ORGANIZE DEFENSE AID SYSTEM

**F**ORTY-ONE civilian defense control centers in Westchester County, New York, will utilize two-way radio equipment, according to Col. Frederick L. Devereux, director of civilian protection here.

The short-wave system will be operated by amateurs on frequencies to be assigned by the Federal Communications Commission. Supplementing the telephone system now in use, it will be used only for defense communications.

Amateurs already have sufficient equipment to put the system in operation within several weeks, Col. Devereux said.

### FM PERMIT EXTENDED

W75NY, Metropolitan Television, Inc., New York, N. Y., was granted modification of its FM construction permit for extension of completion date to December 30.

# ENLIST NOW!



E. D. Wilson, Civilian Defense Administrator, looks on as Russell Brown tunes receiver, while Col. A. G. Couley, Director of Civilian Defense Training, watches Leo Kelly test a Walkie-Talkie at Ft. McPherson, Ga. 2—Two army men carrying out radio duties inside a bomber. 3—An American soldier with latest field transceiver used by forward observation patrols. 4—The radio student must master every phase of the subject; here, adjusting a loop antenna. 5—Staff Sgt. Gloystein transmits with a S. C. R. 288 while Corp. Vantman cranks the generator. 6—A class in electricity and magnetism at Detroit, Michigan.

# HOW SHIP RECEIVERS GIVE AWAY THEIR POSITIONS

By E. H. SCOTT\*

**I**MMEDIATELY after the Pearl Harbor attack and the United States declaration of war on the Nazis and Japs, enemy submarines and surface craft started sinking the ships of the U. S. Merchant Marine carrying the tanks, guns, ammunition and planes overseas.

As each month has gone by the list of sinkings by the "U" boats has steadily increased, and every officer and man of the Merchant Marine knows that when he sails out of port into the open sea he is risking his life, and that any second he may hear a torpedo come crashing into the side of his ship from a "U" boat, a bomb come hurtling down from an enemy plane, or shells bursting on the decks from an enemy surface craft.

## WHY THEY CAN'T LISTEN

Recently an article appeared in one of our leading national magazines entitled "Tanker Men Don't Get Medals." Heading this article was a photograph showing a group of seamen in a cabin passing away the time playing a game of cards, and underneath the photograph this significant caption—"You Can't Listen To A Radio On A Tanker, Or Enemy Subs Might Track You Down If You Do."

The following notice sent out by the Federal Communications Commission to all U. S. ship owners and ship masters explains why "You can't listen to a radio on a tanker":

"Since it is necessary to give full consideration for the safety of the lives of the crews and the safety of the ships, the use or operation of all types of broadcast receivers on board oceangoing ships has been prohibited by Naval authorities since the outbreak of war until a determination can be made of the type of broadcast receivers

\*President, E. H. Scott Laboratories.

which can be used on board with safety. Please refer to subsection 8.130 (b) of the Rules Governing Ship Service which prohibits the use or operation of certain radio receiving equipment on board U. S. oceangoing ships of 1600 gross tons or over. The primary purpose of this regulation is to prohibit the use of receivers on merchant ships which radiate energy to a degree which may disclose the position of the ship to enemy submarines or surface craft."

## ENEMY SUBMARINES FIND POSITION

The use of radio receivers has been prohibited on ships at sea because the sensitive direction-finding equipment aboard every enemy submarine or surface craft within a radius of up to 100 miles or more can pick up the oscillator radiations which every standard radio receiver sends out even though the ship is completely blacked out, and makes it as visible to the "U" boat or enemy surface craft as if it had a searchlight on board, enabling the submarine to get a bearing and steer directly to the ship on which the receiver is being operated and torpedo it.

Unfortunately, only a small number of the officers and men of the Merchant Marine actually believe they are running any risk in operating a radio receiver at sea, and probably attribute the banning of their use a lot of red tape. They cannot see why a radio receiver which is used for the reception of signals, not to transmit them, could possibly give away the position of the ship, and do not realize that the receiver they smuggled or hid on board is radiating a signal every minute it is used and endangers not only the ship but the life of every man on board.

Although the use of radiating radio receivers has been prohibited at sea, we will never know how many ships have been sunk or how many men have lost their lives be-

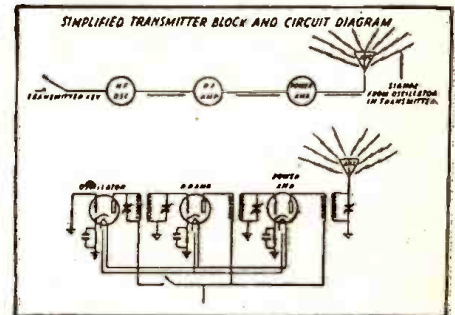

Block and circuit diagrams of ordinary radio receiver radiating R.F. similar to a transmitter.

cause someone used a hidden radio so that he could listen in to the news, and by listening in, lead to his ship a Nazi sub, who fired a torpedo into its hull and sank it.

## WHAT THIS MEANS TO MEN AT SEA

What this lack of radio reception has meant to the men of the Merchant Marine can easily be imagined, for without the use of radio the only thing they have to occupy their minds when off duty is music from a record player, reading, or playing cards. Just what it means for the men on board troop ships going overseas to be cut off from radio reception was described in a dispatch to the *New York Times* from a special correspondent at General MacArthur's headquarters in Australia. This correspondent made the trip in a large convoy of re-modeled liners and fast freighters that went to Australia. He reported: "All radios were silenced during the trip. This lack of war news created considerable strain. Once the convoy reached Australia there was a rush for the radios."

How, you may ask, can a radio receiver TRANSMIT as well as receive signals that can be picked up by a direction finder?

The reason is very simple. Modern radio receivers use an oscillator, which is actually a low-powered transmitter. Unfortunately, in a radio receiver some of the energy produced by the oscillator leaks back through the RF circuits and wiring to the antenna and goes out on the air. It is this signal that is picked up by the enemy submarine and gives away the position of the ship on which the receiver is being used. It will be apparent that the use of a radiating receiver at sea endangers the life of every man aboard.

## HOW RECEIVER GIVES AWAY SHIP'S POSITION TO ENEMY

If you owned a radio receiver ten or twelve years ago you will remember the squeals and howls you used to hear in your set as you tuned the dial "fishing" for new stations. That interference was not caused by your receiver, but was oscillations radiated from another receiver in your vicinity that was picked up on your antenna and came out of the loudspeaker in the form of a squeal or howl.

Modern radio receivers have reduced, by using one or two stages of RF ahead of the oscillator, and by more careful shielding, the amount of the oscillator energy that is radiated to the point where you rarely pick

Dark portion of block and circuit diagram shows paths by which oscillator energy can feed back to antenna and radiate, so giving away position of ship.

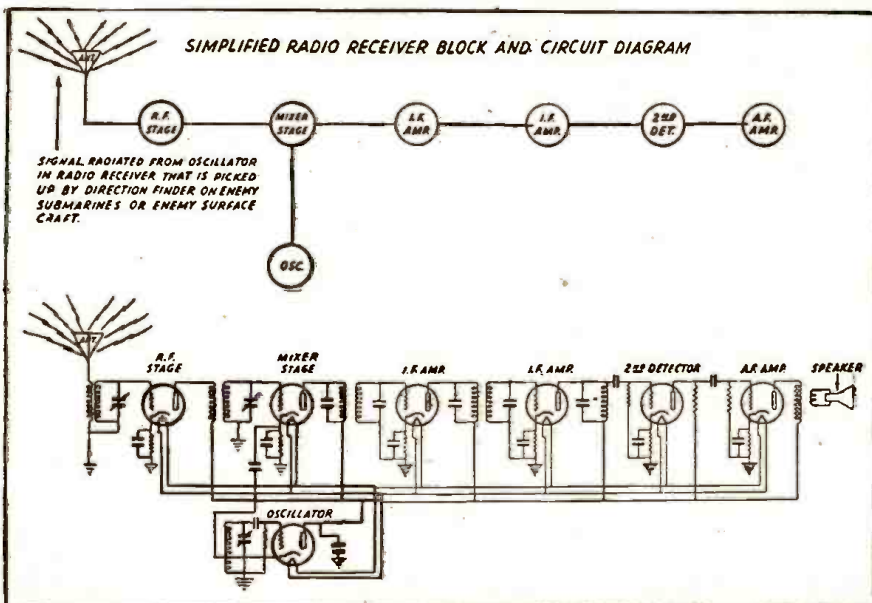

up this type of interference today on an ordinary radio receiver, **BUT IT IS STILL THERE**, and the very sensitive direction-finding equipment used on board enemy submarines can pick it up.

To make the explanation as simple as possible as to why a radio receiver can act as a low-powered transmitter as well as a receiver of signals, I am showing simplified block and circuit diagrams of a transmitter and receiver.

In a CW transmitter, the operator presses a key which opens and closes a circuit to tap out the dots and dashes that are used to send the message. The signal is generated first in the H.F. oscillator, then amplified in the RF amplifier and the power amplifier of the transmitter until it reaches the antenna and goes out over the air.

**WIDE BAND OF FREQUENCIES**

When you tune the dial of a radio receiver from one end of a band to the other, you rotate the variable gang condenser which tunes the oscillator as well as the RF and mixer circuits, and in doing this may tune in 20 or 30 stations which is the equivalent of sending out a signal on 20 or 30 different wave lengths.

It requires no further explanation to see very clearly why it is easy for anyone operating a direction finder on an enemy craft to pick up a ship, get a bearing on its position, quietly steer toward it, fire a torpedo into the hull of the ship, and we read in the papers a few mornings later that another ship was torpedoed in such and such an area, with the loss of so many lives.

In a radio receiver the oscillator is used to generate a signal to beat with the incoming RF signal to the mixer stage, then amplified thru the IF and audio amplifiers, so that you can hear the signal or program thru your loudspeaker.

Unfortunately, however, all of the energy that is generated in the oscillator is not confined to the mixer stage, as will be seen by referring to the red sections in the block and circuit diagrams of the receiver shown on this page for some of it feeds back through the mixer and RF tube to the antenna; some by coupling between the filament and plate supply leads of the Oscillator, and some by direct coupling between the Oscillator and Antenna. The effect of this is that the Oscillator in a radio receiver acts as a low-powered transmitter.

The solution has been found by the Scott Research Laboratories in an entirely new development which actually cuts the Oscillator radiation in the Scott Marine Model SLR-12-A down to such a low point that we do not believe it can be detected 25 feet away, let alone 100 miles—the distance Oscillator radiations can be picked up by the enemy from many regular types of radio receivers.

The Scott Low Radiation Marine Receiver covering the broadcast band and the short waves from 5.6 to 15.1 mcs., has been tested and was approved by the Federal Communications Commission for use on all ships of the Merchant Marine, so that it is now possible for the officers and men on every ship at sea to listen in perfect safety to the news of the world as it is broadcast hour by hour on both the broadcast and shortwave bands, and to once again enjoy their favorite programs of entertainment and music while at sea.

**LOW RADIATION RECEIVER DEVELOPED**

Owing to the fact that tests by the Federal Communications Commission have also shown that all high frequency receivers that have been used up to this time for communications purposes on the ships of

*(Continued on page 123)*

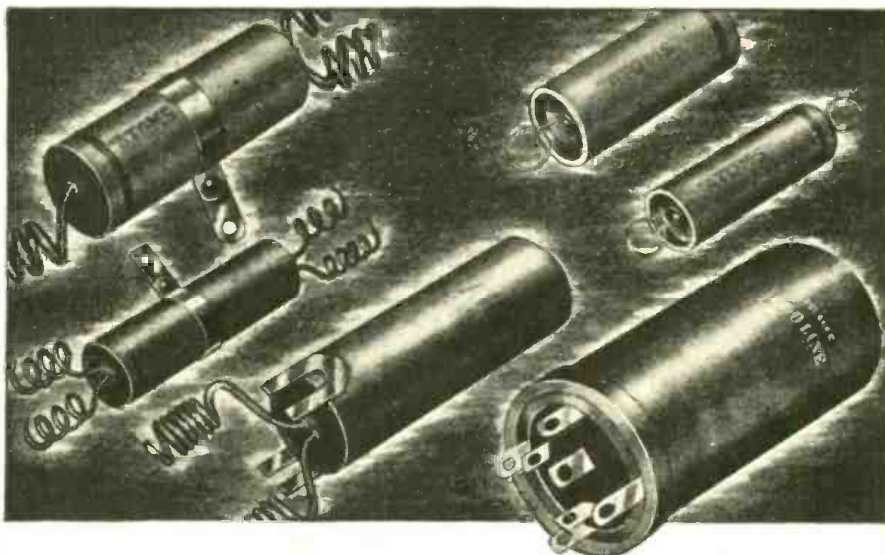

**WHO SAID ANYTHING ABOUT CONDENSER SUBSTITUTES?**

Even if restrictions on metals hadn't eliminated aluminum can, type electrolytic condensers . . .

Even if War demands on leading manufacturers such as Sprague hadn't made it necessary to simplify condenser lines and curtail many "exact duplicate" and other types . . .

The fact remains that leading servicemen would now be using Sprague Atom Midget Drys and Type EL Prong-Base Drys almost universally, anyhow. For these Condensers are definitely not substitutes. They're a big forward step in modern condenser construction. A small stock enables you to replace almost any condenser of equal rating—and do it in less space, at less cost, and with every assurance of better, more dependable performance. Drys or wets, low voltage or high voltage, single capacitors or duals or triples —Atoms and EL's handle them all.

As long as your Sprague jobber has these popular units, you've no need to worry about condenser replacements . . . and you won't be using substitutes. You'll be using condensers that are actually better—condensers that will set the style in efficient servicing for years to come!

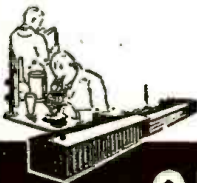

**SPRAGUE PRODUCTS COMPANY**  
North Adams, Mass.

**NO TUBE SHORTAGE**

There need be no apprehension at this time that tubes for radio receivers will not be available because of wartime restrictions. Even though dealers are now "short" on many types, it would appear there is a backlog supply, large enough to take care of normal requirements for the next six months or so.

It was estimated last month by the Radio Manufacturers Association that the present supply of tubes numbers about 35,000,000. The RMA has recommended to the WPB that at least 25,000,000 be produced this year to fill out the 1943 requirements, and it is believed the WPB will make the allocation.

The government has been sponsoring some factories for the duration, to produce the tubes needed for military purposes, thus permitting many of the factories which

make radio tubes for civilian use, to continue their production.

This idea applies to many "radio" parts also.

Credit must be given the tube and parts manufacturers for having anticipated wartime restrictions by building up ample stocks. Otherwise some of the 60,000,000 or so receivers in the U. S. would have been "put out of action," if not rendered entirely useless by lack of parts. Such a course if followed to exhaustion, would have rendered broadcasting virtually useless.

The government recognizes the fact that in modern war, instant radio communication with the entire population is of paramount importance. For that reason, "Radio Must Carry On"—far more so than in peace time.



TUNED TO WAR, plant sound systems add air-raid protection (left), bring managers closer to workers (below).



# PLANT BROADCASTING

**M**ODERN INTRA-PLANT SOUND SYSTEMS hold fascinating, practical answers to many a problem that management faces in striving for more efficiency, more production, and better employee relations.

Right now, in thousands of U. S. war factories and shipyards, plant sound systems quicken the pace of production with speedier communications, help bolster morale, relieve fatigue, and give added air-raid protection. And out of this war experience and from behind-the-scenes research, still newer ways to use sound as an aid to good management are beginning to appear.

As more and more plants are wired for sound, a basic change seems certain to take place in management's mode of communicating with workers. The spoken word can powerfully supplement, in some instances entirely replace, bulletin board posters, handbills, printed messages in pay envelopes, and house organs. And that means a wholly different approach—a forceful, direct one—to bring employer and employees into closer working harmony, with benefits for all.

For instance, brief, to-the-point messages broadcast at meal-times can give workers good advice on proper foods to eat—at home as well as on the job. Specific suggestions on nutritious foods essential to physical fitness may be coupled with helpful comments on production time wasted by avoidable illness. Only recently, one plant lost the full afternoon's work of 138 men and women, who were made ill by cheap candy bought at noontime from a street pushcart. An incident like that could be dramatized over the sound system the next day with telling effect.

Stressing safety precautions to plant workers is another "natural" for plant broadcasting.

In countless other ways—sometimes using sound effects common to standard radio programs—industry has a new technique to lend color and punch to spoken or recorded messages for employees,

in connection with war bond sales, national campaigns on salvage, car-sharing, health, conservation, etc.

Production rallies and Army-Navy E award ceremonies can be recorded and played to second- and third-shift workers. Members of the armed services, perhaps former employees, can spur output by telling how war goods made at the plant perform in actual battle. Announcements of shifts in company policy, changes in officers, employee events, like ball games and dances, birthdays, anniversaries—all these and many others are practical, effective uses for plant broadcasting.

One of the most significant ideas is giving employees music while they work. Flat claims of definite percentage increases in production resulting from playing music for industrial workers may justly be viewed with skepticism. But it is true that increases in output in plants where music is broadcast have been noted. Managers in England, where British Broadcasting Corp. music programs for workers go into most war plants, report advances in output, sometimes as definitely as 6 to 11%. On one point there's general agreement: Music's prime purpose is to boost morale and relieve fatigue. Production gains are an extra dividend.

As an antidote for boredom and fatigue, music proves of real worth. In the brief periods of fatigue occurring during working hours, workers tend to grow careless. When that happens quality of workmanship suffers. And while evidence of fatigue may not show up in volume of work done, it turns up elsewhere—in errors or accident frequency.

The right kind of music played at fatigue periods gives workers a "lift" over these low spots. Music also can provide, with good effect, a soothing, relaxing atmosphere at rest periods and meal-times. In some plants each new shift swings into action in a stirring atmosphere of martial music.



There are three ways to bring music into the plant. Radio stations are broadcasting programs especially for workers that can be picked up by radio receivers and piped through speakers. Or music may be bought from services offered by Muzak Corp. which sends out planned programs to factories over leased telephone lines. As the

Here, the advice of experts is highly desirable, for music that gives best results when played during working hours usually differs from that played at lunchtime and rest periods or as work begins.

The kind of music that seems to help best to improve industrial efficiency is the lively fox trot. Jazzy, blaring numbers are not recommended. Already a great deal has been done to classify music according to the industrial uses for which it is best suited.

To keep pace with the requests submitted by employees may sound expensive. But it need not be. An RCA-Victor service, for instance, supplies a nucleus library of 300 to 500 records, selected to fit the normal needs of the plant, along with program recommendations. Then, a monthly lease service supplies up-to-date records plus employee requests.

Worker reaction to music, beyond a simple yes or no answer to the question "Do you like it?", is now coming in for careful analysis. But the enthusiastic response of workers is apparent to anyone who hears industrial music in action. Labor leaders and union members of union-management committees give firm support to the idea. Workers themselves comment like this: "Makes time short . . . Relieves my mind . . . Keeps me alert . . . Gets you over that tired feeling" and so on. Among workers interviewed by MODERN INDUSTRY for their reaction to music, two actually said they didn't mind at all coming back from vacation, because the music made working so pleasant!

One point on which considerable difference of opinion has been voiced seems now to be answered by experience. That's whether or not vocal selections are distracting. Although there's still some conflicting opinion, many users agree that numbers with vocal choruses belong in industrial music programs. The argument against them is that workers listen for the words, thus don't give proper attention to their work. But provided the singing voice is not extreme in character, there doesn't seem to be any noticeable distracting effect on the workers—though British plants had to eliminate "Deep in the Heart of Texas" because workers stopped work to clap their hands in the chorus.

One of the most remarkable results with music in this case is that it solved the problem of bitter friction after December 7 among workers of many different nationalities. Germans, French, Italians, and Americans had to work side by side. Hardly a shift passed without a few fights. Music changed all that, brought harmony into the worker ranks. Very few rows have taken place since it has been piped into the plant; it puts their minds on other things and they talk less about the war.

The same sound system that brings music to workers in industrial plants may be used for paging, and savings on paging alone may quickly pay for the installation. An aircraft plant, for instance, transmits some 3,000 paging messages daily over its plant system super-imposing them over the music when it is playing. Studies show a saving in time of about four minutes per call. Based on a supervisory wage scale of \$1.50 per hour, the annual dollar savings are estimated at \$109,200.

For both communications and helping to curb any hysteria that might break out in an air-raid or other emergency such as an explosion or fire, the factory sound system can be a highly effective instrument.

Not so immediate in use-value but a strong indication of what might be done with sound systems when manufacturers



Daytime rallies, such as pictured here, may be recorded, and "programmed" thru the plant loudspeakers, to the night shift.



With a microphone handy, inspectors can call workers to the inspection benches, thus avoiding shouting above the din of industrial noises.

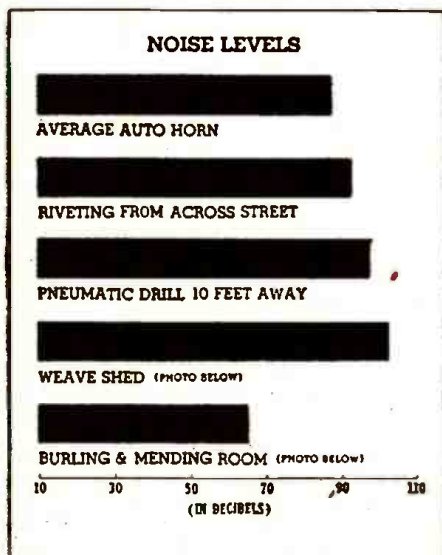

Noise-level chart, showing comparative sound pressures in decibels, of various sources of industrial "loud" noises.

third way, a plant may buy turntable equipment for playing its own records.

Building an adequate library of records calls for particularly careful attention.

Music gets through where noise is incredibly high. On chart above, note that weave shed (below), where music is used successfully, is noisier than a pneumatic drill 10 feet away.



swing back to civilian production is the suggestion of playing, for workers, one-minute transcriptions of consumer complaints. Actual cases would be used, boiled down and presented realistically. Broadcast to the various departments concerned—assembly or final inspection, for instance—these messages might do much to bring home to workers what faulty work or carelessness means to company prestige, volumes of business, wages, and jobs. Ideas of this sort, properly developed, may bring nearer a new era of management-worker understanding with tangible results in better, lower-cost products. Such ideas indicate that postwar uses for intra-plant broadcasting will be far wider than now, since morale and employer-employee relations are probably going to be of even greater concern to management after this exhausting war is won.

—Abstracted from *Modern Industry*,  
New York

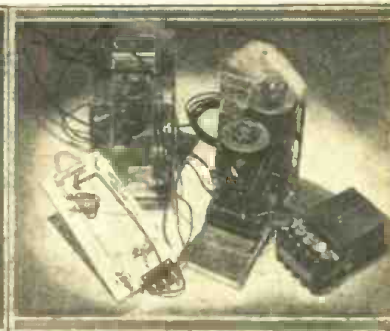
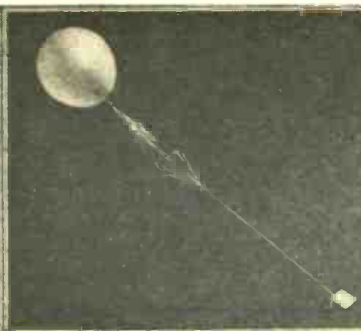

Left—A super regenerative radio receiver, equipped with the necessary dials and ear-phones for tuning, is connected to an electronic frequency meter from which readings of varying temperature and humidity at known altitudes may be noted. Center—The carrier balloon, with the radiosonde trailing below heads for the stratosphere. Right—Working parts of the radiosonde which transmit to the ground receiver the atmospheric conditions in the stratosphere.

## RADIO AIDS WEATHER DATA

ONE of the newest and most valuable instruments yet devised for obtaining information on meteorological conditions in the upper levels of atmosphere, the best source for accurate forecasts, is the radiosonde. Enclosed in a small case or box which is carried into the stratosphere by a balloon about six feet in diameter, the radiosonde's working parts are so constructed as to measure and transmit by radio signal the conditions of air pressure, temperature and humidity. The sound signals from the ascending instrument are picked up by a super regenerative radio receiver located at the ground station. This receiver is equipped with the necessary dials and earphones for tuning, and is electrically connected to an electronic frequency meter from which the readings at known altitudes can be recorded.

The Weather Bureau now has about 40

radiosonde observing stations in the United States where recordings are made by flights launched twice a day. The advantage of the radiosonde over an airplane for this purpose is that it can be sent up in any kind of weather. It also obtains more information than the pilot balloons although these too are still in general use.

When the balloons carrying the radiosonde finally break, the box containing the instrument is lowered to the ground by an attached parachute which prevents damage to the sensitive equipment. About 20 per cent of the radiosondes are recovered.

Up until the present emergency, forecasts were sent out by the Weather Bureau twice a day, for general uses, for morning and afternoon papers and for 600 radio stations which are served. The service has now been stepped up to where it is given every six hours. More than that, the Weather

Bureau has experts on duty around the clock, keeping their fingers constantly on the pulse of the weather and ready on the instant to supply information wherever it is needed.

Climate data gathered by the U. S. Weather Bureau for more than half a century is being translated into usable form for the military authorities, by the Work Projects Administration.

The study is intended to cover areas not only in the United States, but also in Alaska, the Caribbean and the coastal regions of North America. Approximately 25,000,000 airway and surface weather observations from the tons of records on file with the Weather Bureau, will be studied and reduced to punch-card form to enable meteorologists to make any needed information readily accessible to the armed forces.—U. S. Department of Agriculture

## BURGLAR NOW CALLS POLICE

CAPTURING burglars will soon be scarcely more than a routine job, almost as simple as going out to tell some citizen's neighbors they're making too much noise, as a result of an invention by James O. Howton of Freewater, Oregon. It will be so simple that the squad responding to the call can take their choice of walking in and picking up the burglars at work or of waiting quietly outside and nabbing them as they come out with the goods.

The burglars themselves are going to "speed up the service" by calling the nearest police station or cruiser by radio. They will not know they are sending out the alarm because hidden away in a remote part of the building is the Howton Radio Alarm, which by means of contacts with all points of entrance, automatically transmits a recorded voice on a given police radio frequency as soon as any circuit is broken by the opening of a door or the breaking of a window. This broadcast is picked up by police cruisers. So quickly does the apparatus respond to the forced entry that, in more than two hundred tests made in Seattle nearly a year ago, police answered calls within sixty seconds of the alarm.

For example, let us suppose a retail merchant is about to lock up his store for the

night. Before going outside, he switches the system over from day to night control by merely pressing a button. Then, after locking the front door, he presses another button which extinguishes a light on the outside wall and turns on a green light inside a window where it can be seen by the passing patrolman as a signal that everything is as it should be. But if, after locking the front door, he finds that the outside light refuses to be turned off, he knows that he has failed to close a door or window, or that he did not switch the system over to night control. He must, therefore, reenter the store, remedy the oversight and again lock up, going through each step required. He can then go home and rest assured that everything is well protected.

Another circuit employing a double lock automatically changes the system from day to night control. Instead of being required to press the inside button, the merchant turns his key in a second lock on his front door. If every step has been taken correctly up to that time, the key will come out of the lock after turning. But, if any one step has been overlooked, he cannot remove the key and must go back into the building to check up and see what has been overlooked. Coming back in the morning, he cannot un-

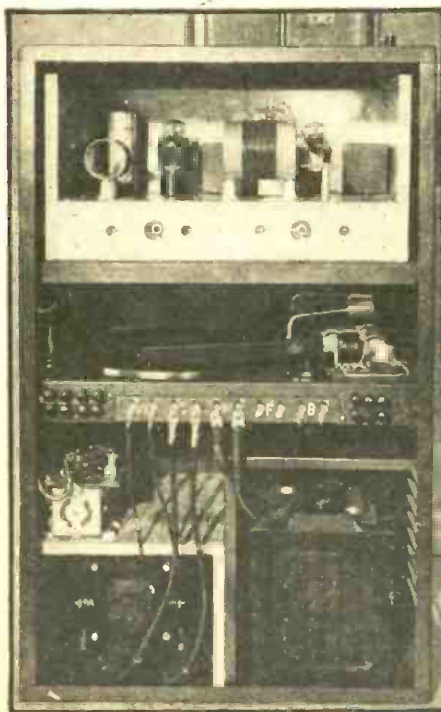

Back view of the burglar alarm receiver.

lock the door until he has shut off the alarm system by first unlocking the extra lock.

But now, some smart stick-up man says, "That's easy. I'll just be on hand when the proprietor opens up in the morning and stick him up after he has the door unlocked and the alarm system shut off." And so he pokes a gun in the back of the business man as he opens the door and goes in. But Mr. Business man has not had time to switch back to day control, and the alarm goes out to the police while they're still going into the store.

Assuming, however, that our stick-up man is wiser than he has appeared in the foregoing incident and gives the proprietor time to shut off the alarm system: He follows into the store and then does his stick-up act. He orders the merchant to open his cash register and hand over the cash, or to open that showcase in which those valuable gems are displayed. The merchant complies with the demand. He presses a key on the register, or he opens the door to the display case and the alarm, without any warning to the culprit, goes into action and, before the criminal has had time to take the money or valuables, the police know what is going on and where. In a few minutes they can be on the job, even succeeding in making the capture as the culprit comes out of the store.

The functions of the alarm are not confined to police work. It also sends out alarms immediately in the event of fire. And still further, should the sprinkler system in a building be set off, or water begin to run in the system for any cause, the alarm will be broadcast.

The equipment uses up to 50 watts of power, and may be operated without a licensed operator.

### DUPLEX PHONO-PICK-UP

The ability to play records without needle scratch and with greater volume is the claim of Christian A. Volf of Van Nuys, Calif., who has secured a patent on a double turn-table, double tone-arm machine. The tone arms are mounted on one pivot, which permits the drag (to one side of the groove) of one tone-arm, to be offset and balanced by the other tone-arm, thus reducing needle scratch to a very low level.

In addition the device has numerous unique uses, such as recording the singing of a vocal student on a blank, and feeding in with that voice simultaneously the output of an amplifier through which an orchestral record on the other turntable is playing. Then on playback the student can hear how his voice sounds, and note faults, etc., to correct. The device also permits playing simultaneously two records of different speeds, or different selections, or different sounds, and the combined output used to obtain unusual effects, or to instruct and test persons who are hard-of-hearing.

ARE

# Coils

YOUR PROBLEM?

For many years Meissner Coils have been the accepted standard by engineers who insist upon high quality performance . . . Meissner precision coil construction never varies . . . they are the best that engineering research and modern production methods can make.

When you specify a Meissner Coil you have the assurance of long, trouble-free operating life backed by a name that is synonymous with precision-built products.

Coils illustrated and described represent only a few of the complete Meissner Coil line.

See your nearest Meissner distributor today.

**Meissner**

MT. CARMEL, ILLINOIS

"PRECISION-BUILT PRODUCTS"

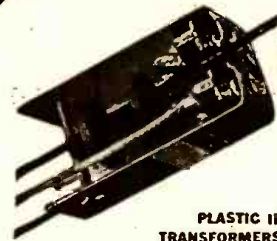

PLASTIC IF TRANSFORMERS

The most popular replacement types. Compact in size, 1 1/4" square, 2 1/4" high. Available in all frequencies from 175 kc. to 456 kc. List price \$1.10 each.



UNIVERSAL ADJUSTABLE COILS

Adjustable — Inductance Ferrocart (Iron Core) coils will replace the broadcast band coils in practically any receiver. 3 types available. Antenna, RF, Oscillator. List price \$1.38



COMPACT ANTENNA—RF COILS

Ideal units for replacement in compact midget or auto Radio sets. Coils wound on form 3/4" in diameter, 1 1/4" long. List prices, either type, Antenna or RF, 50c each.

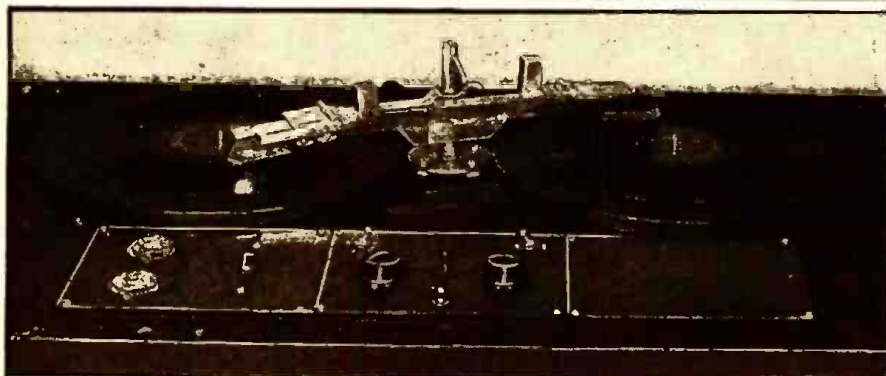

Volfair Duplex Phonograph Pick-up and Recorder.

### CALIBRATING PRECISION METERS

Two electric eyes and one man now do the work of two men in calibrating precision meters. Formerly one man watched a voltmeter and adjusted a rheostat to keep the voltage absolutely constant while the other calibrated the meter. Now a tiny mirror fastened to the end of the voltmeter pointer reflects a beam of light between two photoelectric tubes when the voltage is correct. If the voltage varies, the beam hits one tube or the other, causing an electronic amplifier to make the necessary correction automatically. One man can now do the whole calibrating job.—*National Radio News*

# TROUBLE SHOOTING IN FM RECEIVERS

By WILLARD MOODY\*

**A** FREQUENCY modulated transmitter has its frequency moved up and down at an audio rate. The deviation either side is the same with respect to the central or resting frequency. From experience, field tests by engineers, it has been found that the best deviation ratio

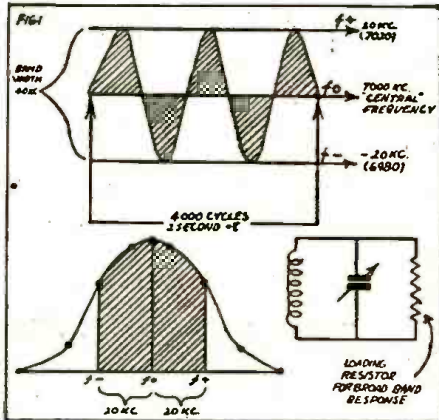

for minimum noise is in practical circuits equal to a factor of 5 times the highest audio frequency to be sent out. If the audio limit is set at 4,000 cycles for voice communication, the deviation will be 4,000 times 5 or 20,000 cycles which is equal to 20 kc. This means the central or unmodulated frequency will be swept up and down, plus or minus, 20 kc. at the rate of 4,000 times per second for an audio signal of 4,000 cycles per second frequency. If the carrier is 7,000 kc., the sidebands will ex-

\* Instructor, commercial operator.

tend from 7,000 plus 20 or 7,020 to 7,000 minus 20 or 6,980; giving the range of 6,980-7,020. This is the bandwidth or "spread" required in the receiver.

If the receiver is designed to respond to a band width of 20 kc. above and below resonance, and if the transmitter is improperly adjusted to give a bandwidth of 40 kc. plus or minus resonance, the receiver will not be capable of responding, due to clipping of the sidebands, and distortion will result. Also, if the receiver is not tuned to resonance with the transmitter's carrier, distortion will result. Should the carrier of the transmitter shift, due to a change in the tuning capacity of the oscillator, the result will be the same as though the receiver were detuned and distortion will be produced. Since the intelligibility of the signal is important and the difference between a garbled and a clear message could involve military disaster, we can see the importance of transmitter stability and proper adjustment. If the audio signal impressed on the modulator tube results in overloading of the modulator, or if the modulator tube is operated so as to have a wider variation in its inductive effect than is needed for frequency modulation within the assigned limits, the result will be distortion.

With a sine wave signal being supplied to the modulator, the oscillator plate current should remain steady. If it wavers, something is screwy and the tube and parts should be checked. The modulator generally operates as a class A amplifier, since there is little power needed for F-M modulation, and the modulator tube's plate current should remain steady when audio voltage is being supplied to the tube's grid. If the plate current varies, it indicates the

tube is running into grid current due to improper bias, over audio excitation voltage, low plate voltage (and consequently, operation on the nonlinear part of the Eg-Ip characteristic) or poor power supply regulation. In some cases, the latter effect will be noticed when the batteries get weak. High resistance batteries have poor regulation, and the potential of batteries under load should not be less than 80% of their normal no-load voltage. A 45-volt battery that falls below about 36 volts should be discarded. This is the voltage when the battery is delivering current. The regulation of any supply will be the voltage under load divided by the open circuit voltage, multiplied by 100.

The simplest way of checking on the carrier shift is to use an F-M receiver in known good condition and to tune it to the transmitter's frequency. If necessary, a well shielded monitor receiver can be used, specially constructed for the work. At resonance, the voltage between the cathodes of the diode detector in the receiver will be zero. The receiver may be tuned for zero potential between cathodes by using a microammeter in series with either diode load resistor, or a vacuum tube voltmeter across the entire diode load. The resistors must be exactly equal if the micro-ammeter method is to be used with accuracy.

The receiver is allowed to stay put and the modulation is applied to the transmitter by simply speaking into the microphone. If the reading on the micro-ammeter or v.t. voltmeter changes at the receiver, a carrier shift is present. The modulator tube and parts can then be checked. The plate-cathode resistance swing of the modulator tube is the same as an inductance swing or change. If the audio input voltage to the grid-cathode of the modulator is too large, the plate-cathode swing will be too great and the bandwidth of the transmitter will exceed the limit of the receiver. It is possible, by increasing the capacity of the oscillator circuit and decreasing the oscillator inductance coil size, to get more capacity, thus limiting the frequency shift. A better method is to reduce the plate or screen potential on the modulator tube or to increase the bias slightly. In some cases it is possible to merely open up or to decrease the size of the condenser across the modulator tube's cathode resistor, thus providing negative feed-back which cuts gain and reduces the modulator tube's plate current swing. Keep in mind that when the modulator tube has a high plate resistance it is the same as a high inductance being shunted across the oscillator's tuned circuit. This means that the frequency of the oscillator will be at its low value. When the plate resistance of the modulator tube decreases it is the same as a decrease in its inductance and the frequency of the oscillator rises since there is less net inductance in the tuned oscillator circuit when the modulator shunt inductance is low in value.

Another important point is that the circuits which follow the oscillator must have the required bandwidth in order to pass the voice frequencies or whatever frequencies are to be transmitted. If the amplifiers are not properly loaded and tuned, the sidebands will be cut, just as in the receiver improper tuning results in sideband cutting. Then, distortion will be pronounced.

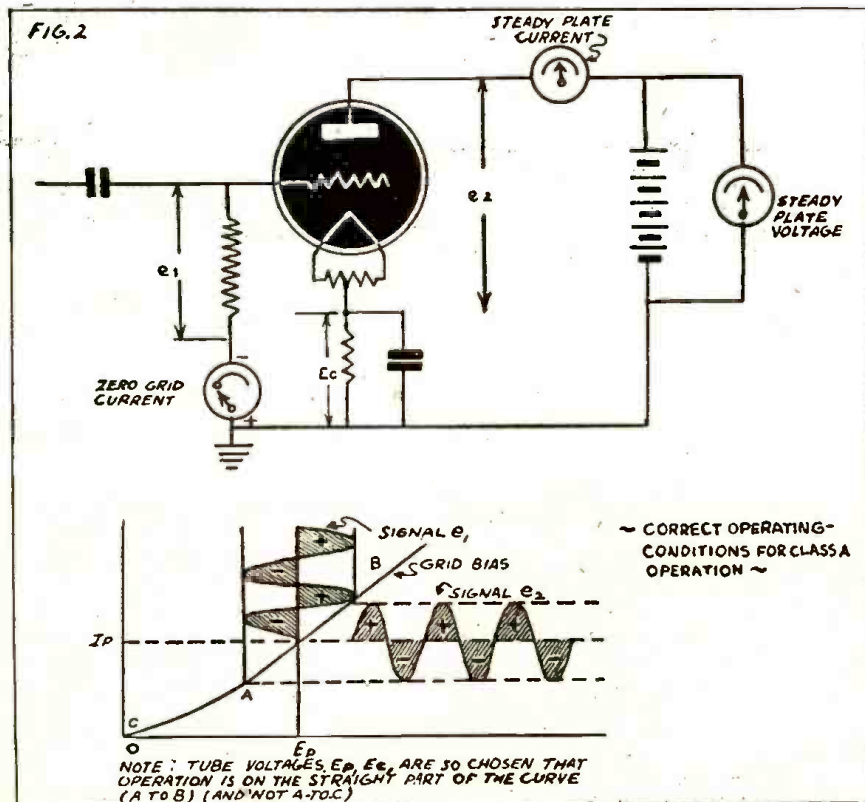

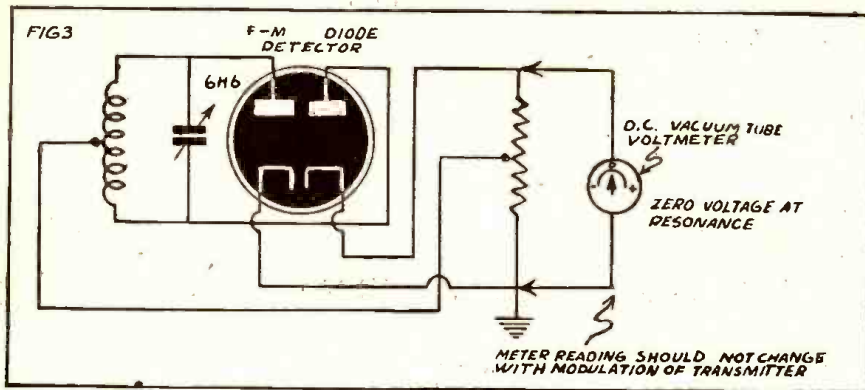

The thing to watch out for in an amplifier is improper neutralization or regeneration. Where screen grid tubes are used and the by-pass condensers are reasonably large, regeneration is usually low and not troublesome. But, if a condenser opens up or develops high power factor due to aging and moisture absorption, a shift in the plate-cathode resistance of an amplifier tube and therefore in the tuning will result. Re-tuning is then necessary. One way of checking an F-M transmitter where it is suspected that regeneration or oscillation is taking place in an amplifier stage is to modulate in the normal way and then to tune a receiver to resonance. In some cases better results are obtained if the receiver is first tuned to resonance with the transmitter unmodulated. Modulation can then be applied and, with the transmitter operating, the quality can be checked on the receiver as a by-pass condenser shunt is connected across each by-pass in the transmitter circuit. Distortion can be cleared and discovered in this way.

In the case of triode type tubes, neutralization is first carried out in the normal way. The plate tank circuit may then be detuned from resonance. If the plate current does not take an immediate increase, the stage is oscillating and is not dependent on the oscillator for its excitation. At very high frequencies the oscillation may be caused by stray coupling between plate and grid circuits, and wires and parts should be checked for proper position. In many cases a coil may be moved slightly due to hard bouncing around of the chassis in a truck or other vehicle.

Keep in mind that the amplifiers working on R.F. in an F-M transmitter must be linear stages capable of passing the bandwidth required for intelligibility. This means class B or class A operation. In low power jobs, especially those employing batteries, class A amplifiers very likely are to be found in the majority of circuits since they are simple to get working.

In any transmitter, the stability is governed largely by the amount of capacitance in the tuned circuits. Should the capacity of the tuning condenser in the oscillator

circuit be altered the tuning will change and distortion will result in the receiver. In a crystal-controlled transmitter, the oscillator frequency is not affected by a change in plate capacity as much as an uncontrolled oscillator is affected. For this reason, the tuning condensers in an F-M transmitter, not having a crystal control system, must be of good quality to begin with and must retain a setting once made. Loose dials, faulty coupling units between dial and condenser, or cold soldered joints to rotors, cannot be tolerated. Worn mounting screws which allow the tuning condenser to "wobble" cannot be allowed, since the frequency would be shifted with every jar given the transmitter. The effects of vibration must be taken into account in servicing such equipment and the same technique peace time servicemen used in repairing

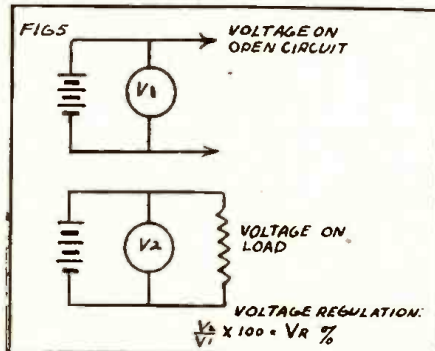

auto radio receivers here applies in large measure. The condensers and resistors are the same, the sockets are nothing new, but all parts are of better quality and more costly; yet even good parts can break down when equipment is splashed through mud and left out in the rain.

A shorted or leaky tube of a transmitter can cause erratic operation in just the same way it does in an ordinary radio receiver, and the simplest way of checking is to have a spare tube on hand so that it can be plugged in and results noted.

In working with antennas, always keep in mind that the antenna will be more efficient the higher it is. The effective height of a half-wave doublet antenna is the wavelength divided by pi (3.14) and the effective height of the vertical grounded antenna may be determined by considering its equivalent as a doublet with one half formed by the ground image. In many cases more output can be gained by driving a metal rod into the earth and grounding the transmitter frame. The antenna then works against ground and if the batteries are weak the extra signal means the difference between not getting through and being heard. The earth then serves as a counterpoise, even though its R.F. resistance may be

(Continued on page 107)

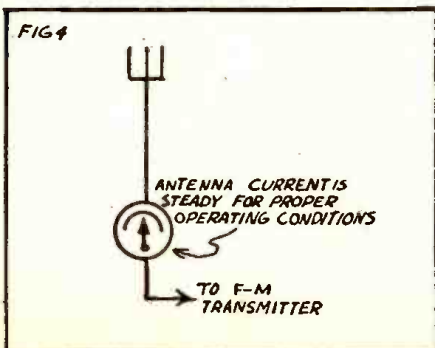

# TECHNICAL BULLETINS

Technical bulletins give reliable information in easy-to-follow form, and save valuable time otherwise spent in laborious reading of numerous books. Every subject is treated briefly and concisely, yet completely. No complicated mathematics, chemistry, electricity, or theory. Each bulletin is written in simple language.

PRICE \$1.00 EACH POSTPAID  
ORDER BY NUMBER

## WELDING, SOLDERING AND BRAZING

**D-105—LATEST GAS-WELDING PRACTICE.**—Contains simplified instructions for using the modern oxyacetylene torch for welding and cutting. Includes instructions for welding steel, cast iron, aluminum and aluminum alloys, lead and lead alloys, nickel and nickel alloys, monel metal, etc. Contains data on lead burning, gas pressure for all jobs, formulas for fluxes.

**D-133—SPOT WELDER FOR THE SMALL SHOP.**—Complete, easy-to-understand directions to build a 110-volt, 50 or 60-cycle A.C. spot welder for fastening light sheet metal. Shows how to make the welder adaptable for operation on 110 or 220-volt, 25-cycle current, or 220-volt, 50 or 60-cycle current.

**D-136—SMALL A.C. ARC WELDER CONSTRUCTION AND USE.**—Tells how to build arc welders capable of fusing iron and steel sheet up to 3/16 inch in thickness and rods as large as 1/4 inch in diameter for use on 110-volt, 60-cycle A.C., 110-volt 25-cycle A.C. or on 220-volt 60 cycle A.C.

**D-135—WELDING SHEET METAL WITH EASILY MADE ELECTRIC ARC TORCH.**—A small carbon-electrode arc torch that operates on 110-volt A.C. current. Of value to metal-working shops and home work shops for soldering and brazing, and even light welding on sheet metal. Can also be used to melt small quantities of metals and alloys. Also used by dentists to melt gold.

**D-122—WORKING WITH STAINLESS STEEL. SOLDERING, BRAZING, AND WELDING.**—Complete practical methods of soldering, brazing and welding stainless steel, including formulas for solders and fluxes and other practical data.

**D-124—SOLDERING ALL METALS, INCLUDING ALUMINUM, AND ALLOYS AND DIE CAST ALLOYS.**—How to produce perfectly soldered joints of neat appearance. Identification of light metal alloys. Solders and soldering fluxes and how to make them. How to make electric soldering irons for light and heavy work, how to construct an alcohol blowpipe.

**D-104—SILVER SOLDERING AND BRAZING.**—Explains practical methods of brazing, silver soldering, and hard soldering. Contains tables giving the composition of brazing and soldering alloys, formulas for fluxes.

**D-141—RECORDING THERMOMETER EASILY MADE.**—Full information on building an accurate device to record temperature changes over 12 hour periods. Uses any type of clock and a sensitive element carrying a pen that marks temperature fluctuations on a paper chart.

Each Bulletin consists of a set of large sheets, assembled in one packet, size 9 x 14 1/2"; weight 1/4 lb. Numerous illustrations, diagrams, charts to supplement text.

## TECHNIFAX

1917 S. STATE ST. RC1142 CHICAGO, ILL.

RC1142

**TECHNIFAX** 1917 So. State, Chicago, Ill.

Enclosed find \$..... for which please send me postpaid the following Technical Bulletins:

Nos. ....

Name .....

Street and Number .....

City and State .....

# PULSE GENERATORS AND THEIR FUTURE

By WERNER MULLER

SOMEONE said, not so long ago "there is nothing doing anymore in the radio field." The statement is quite true but he forgot to take into consideration that by using known principles and adapting them in unique ways new fields would open up, and this is exactly what is happening in the field of pulse generation and the application of these pulses for the purpose of communication, measurements and various other developments that only lately have been applied by the enterprising genius of the electronics engineer.

The exact uses of pulses in the electronic arts cannot be divulged since a large part of the application is of a military nature, but the underlying principles of how to produce and control them is not new, since television makes exclusive use of them. For the average technician little practical information is available and this article will try to convey a few pointers on the fundamentals involved in producing pulses similar to those now being used.

The progressive technician will realize the value of this information since it will cover a few points pertaining to constructional features and possible faults that may be experienced. Having these few facts in mind, the average technician should be able to adapt himself to emergency service, if and when he should be called upon to render same. Theoretical details will be kept to a minimum and references will be made in those cases to standard texts as found in engineering handbooks. The highlights that will be covered will be of a practical nature and as simple as possible. In breaking the analysis down so as to have the technician understand the functions properly, little or no mathematics will be included. The article is intended to be of an instructive nature in practical ways. Since no particular application of pulse generators can be written about, only the necessary steps and methods to obtain pulse generation will be discussed.

Applications of pulses in commercial fields can be observed in television, but pulses as used in this branch of electronics are only of partial use; the pulses desired being of similar form but of varying character (See Fig. 1A).

The pulses as shown in Fig. 1b are those that we are generally concerned with. It is their amplitude and width that is of chief interest to us.

It is assumed that the reader is familiar

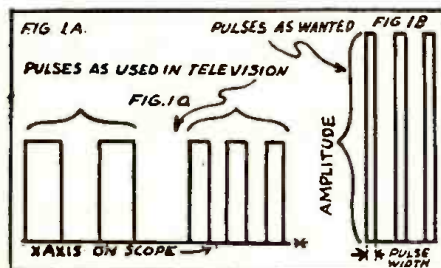

with oscillators of the sine wave generator type covering both audio and radio frequencies. No particular use of these forms of generators is suggested, since the methods of utilizing these generators for square wave pulses requires additional apparatus, but a complete description of the necessary steps required for converting sine waves into pulses of the desired form, will be given in a future article.

Other types of generators are those of

**FOR THE FIRST TIME**  
IN ANY RADIO PUBLICATION

Pulse generators are new to radio and are likely to open up an entirely new field in the art. For military reasons it is not possible to give the important applications to which pulse generators are now applied, but the field is really a tremendous one. Keep your eyes on pulse generators in the future.

the saw-tooth, relaxation, and multivibrator type. Since the size and ease of operation is important, for a number of reasons such as material, tubes, circuits, etc., the multivibrator seems to be the generator best suited for producing pulses. Of course the mere construction of a multivibrator does not furnish the type of pulses that are to be discussed, but fundamentally its char-

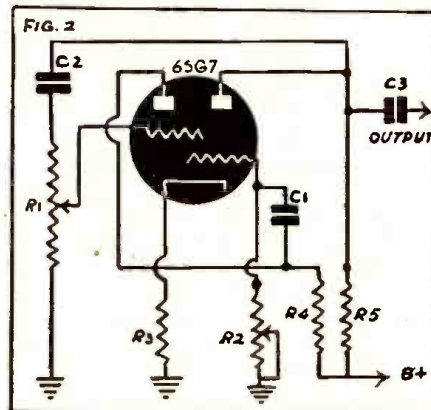

acteristics are such as to permit its wave form being used in pulse generation.

Briefly, a multivibrator consists of two tubes (or two triodes in one envelope, such as 6SC7, 6SN7, 6F8, 6D8 types) where the circuit elements are so arranged as to permit feedback from output to input. The control of the frequency is accomplished by varying R, located in the grid circuit of the second tube, or by varying C, the coupling condenser between plate of No. 1 tube and grid of No. 2 tube, or both.

In the diagram Fig. 2, frequency is determined by the settings of C1 and R2. Commonly R1 is called synchronization control, and R2, frequency control. R1 and C2 is a feedback circuit used for synchronization purposes and for obtaining a certain amount of stability. The value of C2 depends on the frequency used, and in cases of higher orders of frequency generation, that is, about 5000 cycles and up, it may be omitted with some tubes (high- $\mu$  type) since enough feedback occurs within the tube elements. But at lower frequencies the feedback condenser C2 and the synchronization control R1 must have definite values.

C1 if made large will give a low fre-

quency, while if made smaller will increase the frequency. R2 is usually the variable and its size depends on the frequency desired. At this point it would be well to remember that when the correct overall resistance has been determined, this resistance should be separated into two components, one fixed, and one variable, with a relationship of such character that the variable is large enough to cover only a small percentage of the desired frequency. By doing this, circuit variations can be compensated for more easily and in frequency division work it is simpler to select the proper point. No exact percentage value can be given since too many variables come into effect, and it is fairly simple to determine the exact operating point while experimenting. The higher the ratio of fixed resistance to variable resistances, the easier it will be to stabilize the final frequency.

There is a limit to the frequency generated by the multi-vibrator in certain applications, since to isolate higher frequencies for special applications tends to bring in questions of stability and other circuit difficulties. The exact limits have not been determined by the writer, but good results have been obtained with frequencies as high as 300 kc., and with good stability.

To obtain a certain frequency the following formula is useful and will help in arriving at a close point of operation.

$$F = \frac{1}{R_4 C_2 \pm R_3 C_1} \quad \text{Fig. 3}$$

If the multivibrator is used for dividing or multiplying some other frequency, it can be easily accomplished. In that case the synchronizing frequency is obtained from an external source and the circuit of C1, R1 and R2 will then either divide or multiply the base frequency fed into the multivibrator (See Fig. 4). Of course this is limiting the field of adjustment to a minimum. It should be kept in mind, however, that changes of other components in the circuit will affect the output frequency. (A more detailed study of all effective factors will be available at some future date.) The number of divisions can be as high as 15 to 1 with some stability but generally a smaller ratio is desirable since stability is increased.

It should also be borne in mind that all variables that are used for adjusting frequency should be replaced in any final model

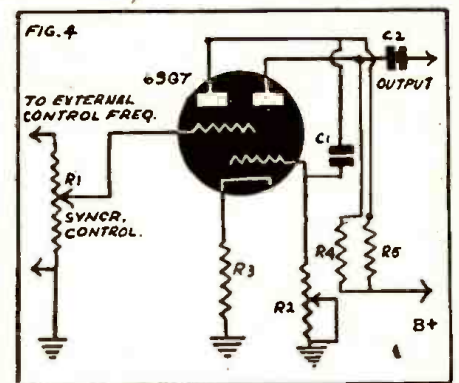

by a fixed resistor. All variables will develop trouble in effect that their resistance factor changes with age and atmospherics. When one is ready to install fixed resistors, after having determined the desired values,

the ordinary carbon resistor is suggested, with its value slightly less than that of the variable measured, and by scraping the carbon element a little at a time, the correct value can be derived at. The carbon resistor is then painted or coated with a moisture-proof material (there are any number of resin compounds that will fill the bill) and let dry. This assures permanency of calibration. These facts are to be kept in mind for critical multi-vibrator applications where frequency is to be as stable as possible.

The wave form of the multivibrator is

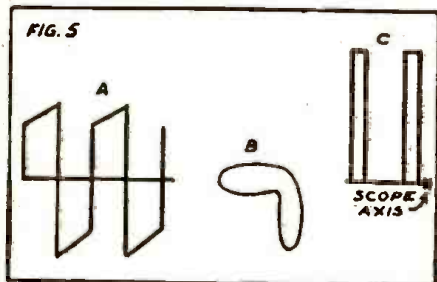

of a pulsing nature and has some straightness to its sides. This fact is important in the case of simplicity, since fewer tubes for squaring are required. But this square wave is not the ultimate pulse desired and other circuits must be used to establish the desired form (See Fig. 5). The voltage output from a multivibrator usually suffices, but at times a voltage amplifier must be used.

In Figure 5a is shown the output of the multivibrator, and Fig. 5b shows the form

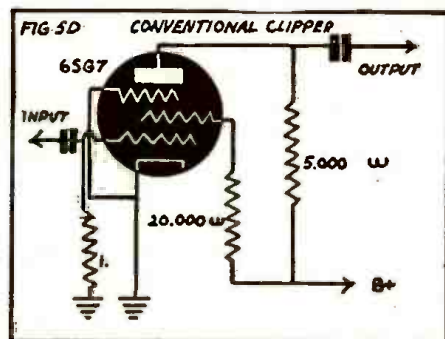

as it appears on the oscilloscope when synchronized against a sine wave of equal frequency. Now to obtain Fig. 5c some additional circuits must be used. The required circuits will be described in their sequence of use. First comes the squaring circuit. (See Fig. 5d). In everyday engineering parlance this method is described as "clipping," or the tube used is referred to as the "clipper." This means that the multivibrator output is fed into an amplifier tube that operates in such fashion as to clip the waveform tops. This action is accomplished by operating the grid and plate circuits of the clipper tube in such a way as to cause saturation to take place in the plate circuit of the clipper tube. This is also known as "limiter" action. (For more details see "Radio Engineering Handbook" by H. K. Henney, J. F. Rider, "Frequency Modulation," D. Fink, "Television Engineering".)

To obtain saturation, a low plate impedance or resistance and a low plate voltage, plus a high input voltage to the grid will usually produce the results. But here is where you must watch out. The frequency to be squared may not come out absolutely square, but may have round edges or other form, such as shown in Figure 6b, c and d.

b. This is due to lack of low frequency response

c. Lack of high frequency response

d. Improper output constants

In the case where only low frequencies (below 5000 cycles) are used, the procedure is fairly simple, that is, either the R or C constants are improper, and by experiment correct values will be found that will give the result as shown in Figure 6a. Without being too technical, for easier understanding, one important fact to know and remember is that the square wave obtained is a very complex form of wave that besides its fundamental frequency also has harmonics.

For example in the case of a 10,000 cycle wave a harmonic up to 20 times the fundamental will be present. This must be kept in mind in case additional amplification is necessary. If this fact is overlooked the results obtained will be very poor. Obviously any amplifier that follows must have a wide-band frequency response. Of course where the frequency is of a lower order the problem is not as difficult.

It is now assumed that working with a proper circuit the output wave form is square, as observed on the oscilloscope. The next step is now to be determined. It has been already stated what form of wave we want: A pulse. Now, it must be kept in mind that pulses can be of a variety of shapes, the particular one we are interested in is of the long narrow type with a flat top (square top) that is it has steep sides and a flat top. But since we have a square wave as obtained from the clipper, we should be satisfied, but this is not so. The pulse, as observed, is square, perhaps too wide. To obtain maximum benefit, accomplished when the pulse is of shortest duration with highest amplitude, we now come to the point where we have to narrow the pulse. By doing this we also will increase its amplitude and its usefulness by changing the shape.

To obtain this necessary function we have to resort to an additional tube. In engineering terms this tube is usually called the "pipper." The reason for the name is because the tube permits only a certain part of the wave to pass through and in this case it is the upper part. This wave form (pipper wave) is obtained by biasing the tube sufficiently high enough so that it amplifies only the upper portion of the entering wave. Since a square wave is fed into the tube the resultant will be as shown in Figure 6c. Of course the height of the pipper wave is determined by the amount of bias.

We now come to the point of converting

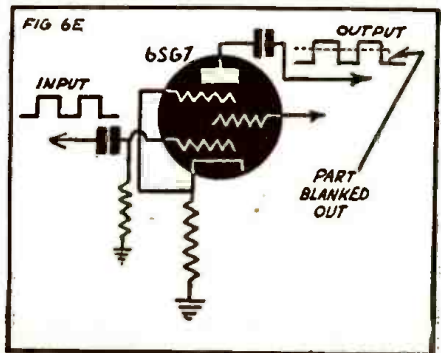
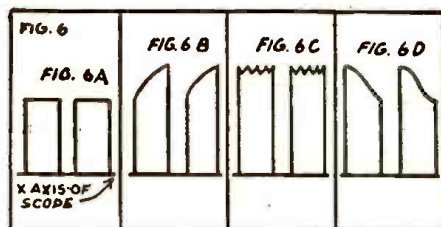

the square waves into pulses. We have to refer back to the input of the pipper stage. It is here where part of the character of the pulse is developed by resorting to a differentiator circuit made up of the required values of resistance and capacity. Fig. 7 shows a differentiator circuit.

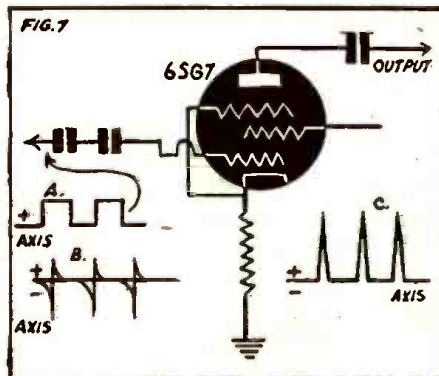
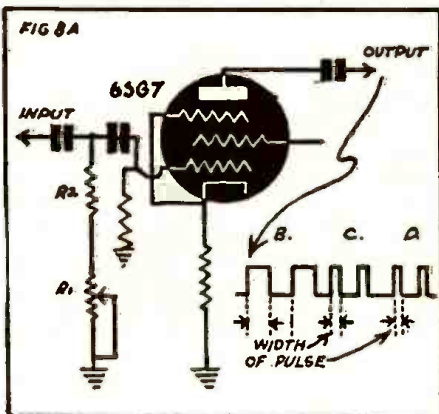

Fig. 7a shows the square wave input; the second figure, 7b, shows the grid input pulses. We also observe that a little kick-back pulse still remains. In the Fig. 7b we notice that the negative pulse is larger than the positive pulse. This can be changed by arranging the node character and bias of the tube. That is, we can develop the pulse in either a positive or a negative direction by correct driving from the clipper stage,



the direction depending on the requirements of the ultimate equipment or circuit function. We also observe that the duration of the pulse is rather short, that is, it is narrow and very pointed at the peak.

The form of the pulse shown in Fig. 7c may be useful in some instances but where extenuating demands are made, we must be able to vary the width of the pulse, and still maintain its square character. To obtain this, one of the simplest methods is to add a variable control in the differentiator circuit. Its size is of course determined by frequency and the values of the differentiator circuit. Tube circuits also may have to be readjusted. In Figure 8a, the control R1 is shown and in Figs. 8b and 8c its effect, when varied, on the width of the pulse. R2 is only a limiting resistor. By proper design we can produce a pulse that will vary over a fairly large duration.

In the cases where square wave measurements are essential, it is highly important that the duration, or the width of pulse, can be varied. If we know the frequency of the wave and the sweep frequency of the oscilloscope, we can determine the duration of the pulse, or its width, and this can then be put into actual time constants. That is, the duration can be expressed in milli-

(Continued on page 121)

# •LATEST RADIO APPARATUS•

## NEW PHONOGRAPH NEEDLE

Jensen Industries  
Chicago, Ill.

**PETER L. JENSEN**, former president of the Jensen Company, manufacturers of loud speakers, has recently marketed a new type of phonograph needle which may revolutionize the art.

"The peculiar design of this new needle," says Mr. Jensen, "was arrived at after a



Peter Jensen demonstrates the unique spring action of his new concert phonograph needle with a man size model. Insert shows actual size of new needle.

most painstaking period of careful research. It was our aim to produce a very long life needle, which would reduce scratch and wear on records, and have a high fidelity characteristic. The *compliance* of the needle gives it a shock-absorbing characteristic which permits it to do this.

"By making the needle rigid in a cross-wise plane, all the frequencies in the record are transmitted without loss to the mechanism in the pick-up. The flattened cross-section causes less air to be agitated directly, and the result is a noticeable reduction in 'needle talk.'

"The point of the needle is an alloy of precious metals, made to have great wear-resisting qualities rather than extreme hardness."—*Radio-Craft*.

## NEW LIMIT SWITCH

General Electric Company  
Schenectady, New York

**A** NEW lightweight limit switch designed especially for aircraft applications has been introduced by the General Electric Company.

The contact mechanism used is the G.E. switchette. Snap action and double-break operation give the switch a high current rating. The switch is designed to meet all U.S. Army Air Forces stipulations. The

plunger operates with a 7/32 in. overtravel, which increases the number of applications for which the switch can be used.

The aluminum housing is made dustproof by the use of a gasketed cover. There is adequate space inside the housing for easy wiring. The switch is available in three contact arrangements: single-circuit, normally open or normally closed; and single-pole, double-throw.

Each form can be furnished with a contact air gap of .010, .020, or .030 in. The switch weighs 13 lbs.—*Radio-Craft*

## INSULATED COIL FORMS

Precision Paper Tube Company  
2033 W. Charleston St., Chicago Illinois

**H**IGHER corrosion resistance in bobbins for coil windings has been achieved by a method of construction in which cellulose acetate is embodied in the bobbins.

Cellulose acetate is used in combination with the spiral-wound dielectric fish-paper core and vulcanized fibre flanges. Spiral wound laminations of cellulose acetate are made over a die to the O.D. of the core and then with a press-fit, slipped over the core to form a spacing tube. The length of the acetate determines the winding area. The inside faces of the fibre flanges are laminated with cellulose acetate before die-cutting, the core then swaged, locking the flanges in place onto the core carrying the spacing tube. Acetate cement is brushed over the joinings to give complete protection and materially to strengthen the bobbin. Phantom view of the new Precision Bobbin indicates this construction.

There are few uses in which coils do not suffer from moisture to some degree; consequently this cellulose acetate protection will be appreciated by users of coils. With this protection super-insulation is established, strength is increased and life of the coil greatly prolonged.

Uses of this form of coil bobbin are wide; instruments and equipment on aircraft, ordnance, marine services and all uses in which coils are subject to corrosion due to temperature and climatic changes.

Precision Bobbins are furnished in all forms—round, square, rectangular, and special shapes to fit engineering conditions.

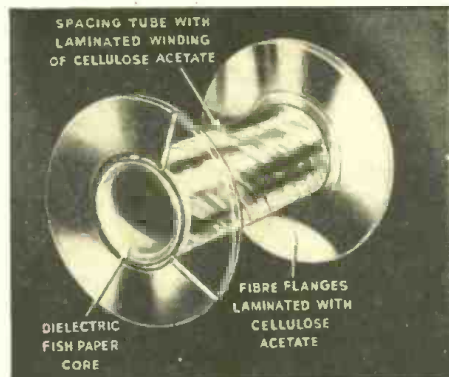

The improvement constitutes another addition to Precision's characteristic of light weight, strength, space-saving and super-insulation. It is claimed that Precision are the lightest bobbin-type coil forms manufactured and that their space saving permits smaller coils with the same gauge of wire and the same number of turns.

—*Radio-Craft*

## SOLDER POTS

Lectrohm, Inc., Cicero, Ill.

**S**MALL solder pots in 1 3/4 and 2-pound sizes are now being manufactured by this company for continuous operation in radio, motor and similar electrical equip-

ment plants, where individual soldering melting pots are desired for each operator or for small repair and homecraft shops. They are sturdily constructed, consisting of a cast iron pot mounted, by a single screw, on a



plated steel stand. A single-heat, porcelain nickel-chrome heating element, which can be quickly and inexpensively replaced when necessary, heats the pot. A six-foot Underwriters approved cord and attachment plug is furnished with each unit. Worthwhile savings are effected by these solder pots through low initial investment, reduced current consumption and lower solder cost. Complete information and prices may be obtained by writing direct to the manufacturer.—*Radio-Craft*

## BERYLLIUM COPPER FUSE CLIPS

Littelfuse, Incorporated

4757 Ravenswood Avenue, Chicago, Illinois

**E**NGINEERS have compiled results of the widespread use of the new Littelfuse Beryllium Copper Fuse Clips—with astonishing results. The higher qualities developed by the clip in fatigue resistance,



tensile strength, modulus of elasticity, heat resistance, corrosion resistance, and vibration resistance, set the clip apart as an important advance in fusing science.

The Clip made from a new alloy of Beryllium and Copper, has spring quality equal to steel. It has three times the grip of the best phosphor bronze clip.

These findings come from the use of the fuse in aircraft, ordnance, marine services, communications, and instrument services subject to the most severe conditions. They are embodied in a new bulletin which may be had on application to Littelfuse, Inc.

—*Radio-Craft*

## NEW MICRO SWITCH ACTUATOR

Micro Switch Corporation  
Freeport, Illinois

**T**HIS new Micro Switch Actuator, although specifically designed for use in the throttle mechanism of an airplane, has potentialities for wide application in other fields.

The new actuator, catalog listed as Type "T," provides a positive means of circuit-closure, plus a manual-release feature that automatically resets the switch for the next cycle of operation. Additional advantages include small size and light weight.

The actuator accepts the Type R31 switch,



Army Air Corps approved, and replaceable in the field. The actuator is considered part of the aircraft, and no deviation permit is required for use of the actuator for aircraft, the manufacturer advises.

The actuator is supplied as a single unit,

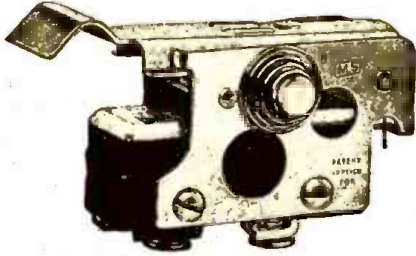

or in gang assemblies of 2, 3, or 4 units, left or right hand, spaced to meet customers' specifications. Use of the actuator with the Type R31 Micro Switch permits elimination of a number of special relays and associated circuits now used in throttle warning applications.

Specifications and samples are available from the manufacturer to engineers.—*Radio-Craft*

**WAVE TRAP AND SIGNAL BOOSTER**

Gold Shield Products  
350 Greenwich Street, New York, N. Y.

THE Lektrofone wave trap and signal booster employs tunable parallel-resonant rejector circuit for separating overlapping broadcast stations. It is claimed that this wave trap will reject or tune out modulated carrier frequencies having a signal strength of 100,000 microvolts and it will function over any part of the broadcast band. By



furnishing a clear channel to the desired signal it serves also as a signal booster, permitting weaker stations to be tuned in with greater volume.

The Lektrofone Wave Trap and Signal Booster is 3 ins. x 2 1/4 ins. x 1 1/4 ins. and is built into a black cracle-finished metal casing, with tuning knob on top and with the two binding posts located on one side. One binding post connects to the antenna and the other to the antenna post of the radio set. To tune out the unwanted station one turns the knob slowly until the interference disappears.—*Radio-Craft*

**STAPLES**

Eagle Electric Mfg. Co., Inc.  
23-10 Bridge Plaza South  
Long Island City, New York

EAGLE Electric announced that it has acquired the Ace Insulated Staple Company and can now offer to the trade the



regular two-legged staples as well as the Eagle Nail-It staple and the insulated wiring nails.—*Radio-Craft*

**ARMY-NAVY "E" AWARD**

Philadelphia, Pa.

The International Resistance Company has been awarded the Army-Navy "E", for "high achievement in the production of war equipment." We of the radio industry are proud to learn IRC has joined the ranks of those who are "hitting on all cylinders" for the war effort.

**COAXIAL CABLE**

Simplex Wire & Cable Co.,  
Cambridge, Mass.

A NEW type of Coaxial Cable with a recently developed low-loss insulation suitable for radio, television, control, and test equipment has been developed. It meets the extremely severe requirements of military specifications for high-frequency, low-loss cables.

A typical construction is the central conductor insulated to a suitable diameter with recently developed low-loss dielectric, covered with a copper braid to serve as a concentric outer conductor and the entire assembly protected by a jacket or sheath of a synthetic plastic.

Such a cable is flexible, easy to install, can be used on the highest radio frequencies, and is so constructed that moisture cannot enter nor can there be any internal condensation. The elimination of all these hazards has resulted in a new cable far superior to any heretofore available.

At high frequencies the attenuation of a cable insulated with rubber insulation may become prohibitive. The beaded type, gas filled cables have a very low attenuation, an extremely important characteristic, but they are sensitive to moisture. The new coaxial has a solid type of insulation with extremely low losses. It is a high frequency cable with attenuation values comparable to that of any of the former constructions.

The new high frequency cables are designed with the basic idea of keeping a proper balance between the mechanical and electrical characteristics. Coaxial Cables insulated with this extra low loss, solid type of insulation and protected with a plastex jacket are being extensively used and are giving a most satisfactory performance.—*Radio Craft*

**NEW TUBE CHECKERS**

General Electric Co.,  
Bridgeport, Conn.

Two new radio tube checkers, one a portable model (illustrated) in a wood case with brown leatherette cover, the other a counter model enclosed in a metal case, grey in finish, have been announced by H. J. Mandernach of the Renewal Tube Sales Section. They are available only on orders carrying at least an A-1-J preference rating.

These new tube checkers, known as Models TC3 and TC3P, will take care of all present tubes and any tubes that may be announced in the future. This is made possible through the use of a special switching system that provides any voltages that may be necessary to test the tubes. The instruments also provide a triple test for output, and a thorough check for shorts.—*Radio-Craft*

**PROTECTING THE VOICE AND EARS OF OUR FIGHTING FORCES**

Lives—Victories—depend on the proper performance of the radio equipment which is the voice and ears of our fighting forces. Army and Navy technicians depend on the same accuracy, dependability and ease of operation which have made the name Supreme famous for over 14 years.

Supreme Radio Testing Instruments keep communications open.

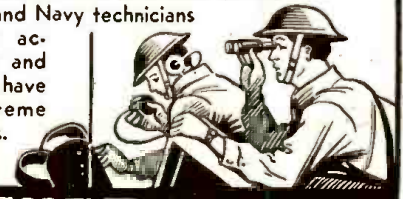

**SUPREME** GREENWOOD, MISSISSIPPI U. S. A.  
TESTING INSTRUMENTS

**NEW CATALOG**

OF SOUND AMPLIFYING SYSTEMS  
AUDIOGRAPH Sound Systems represent the latest in Public Address equipment—a complete line plus pre-tested accessories.

**NEW LOWER PRICES**

Outstanding quality and performance at prices that help you meet any competition.

WRITE FOR YOUR FREE COPY

**AUDIOGRAPH**  
THE FIRST NAME IN SOUND

**Choose the CANNON-BALL HEADSET**

You Like Best



Scientifically Built  
Heavy bar magnets greatly increase their efficiency.

Rugged construction. Inside or outside terminals. Sensitive. Clear tone. Dependable quality. Headset Headquarters guarantees satisfaction. Write for folder C-11.

C. F. CANNON COMPANY  
SPRINGWATER, N. Y.

**Do you need BINDING POSTS?**



The XL PUSH POST with its Spring Action assures Constant Contact and quick connection.  
Manufactured in All Aluminum Type M at 12c each.  
Aluminum Body, Bakelite Top Type M1 at 15c each.  
Types CP or NP. ALL BRASS—STAINLESS STEEL SPRING & PIN. PROVEN BY 240 HR. SALT SPRAY TEST as NON-CORROSIVE at 25c each.

Manufacturers and Dealers Liberal Discounts  
**X. L. RADIO LABORATORIES**  
420 West Chicago Ave., Chicago, Ill.

New Handy **UNIVERSAL REPLACEMENT Capacitors**

Write for Catalog

**SOLAR MFG. CORP., Bayonne, N. J.**

**USED Correspondence Courses**

COMPLETE HOME-STUDY COURSES and educational books, slightly used. Bold, rented, exchanged. All subjects. Money-back guarantee. Cash paid for used courses. Full details and illustrated 76-page bargain catalog FREE. Write today! **NELSON COMPANY, 800 Sherman, Dept. L-210, Chicago**

# GETTING STARTED IN RADIO

By C. W. PALMER

## PART II

**A**T the broadcasting station the antenna system (aerial and ground) is used to create the electromagnetic radiations that we commonly call "radio waves," which travel out into space. For this reason, transmitting aeri-als are designed so that a maximum amount of power is radiated. At the receiving set, on the other hand, the function of the antenna is to act as a circuit in which the passing waves from the broadcasting station may be picked up (induced) in a manner very much the same as the example given in Fig. 10 of the first article of this series, in which a current was induced in the second coil when the switch was closed. (Refer to page 52 of the October, 1942, issue.) The waves that make up the signals from the transmitting station cause corresponding high frequency alternating currents to flow up and down through the circuit between the aerial and ground, which really forms the plates of a large condenser (like the plates of the variable condenser in our set). This effect is shown in Fig. 1.

### TYPES OF ANTENNAS

A number of forms of antennas have been devised for transmitting and receiving, some of which are generally useful and others which have special characteristics that adapt them to a particular use.

Figure 2 shows three simple forms of antennas. At the left is the vertical type, consisting of a single wire suspended vertically in the air. This type of aerial receives equally well in all directions. At the center of the illustration is the T-type aerial, consisting of a wire suspended horizontally with a vertical connecting wire (called the lead-in) at the central point. Antennas of this type receive best from the two directions of the ends of the horizontal wire. At the right of Fig. 2 is the inverted L-type aerial, commonly used because of the convenience of erecting it. It receives best from the direction of the lead-in. For most wavelengths, the directional effects of these three aeri-als are not very pronounced; however, on certain wavelengths, especially on certain very short ones, the directional effect of the inverted L is quite marked.

In Fig. 3 are shown two other less common types of aeri-als. The left one is the horizontal V-type, which receives best from the direction of the lead-in. The other is known as the umbrella type because of its resemblance to the ribs of an umbrella. This type is much less common than the others because of its complicated structure. It is used more frequently for transmitting, because of its low resistance and also because it sends equally well in all directions.

### THE ANTENNA INSTALLATION

Any attempt to set down rules for making an aerial of definite dimensions would be foolish, as we can all see. Every antenna installation presents different conditions; thus it is perfectly easy to say that the ideal aerial for general short-wave reception is one 50 feet long and 100 feet high, but it may not be practical to follow these instructions because of the surrounding layout of buildings, etc. In crowded locations, such as city apartment houses where one encounters difficulties because of the presence of other aeri-als and finds no convenient sup-

port for the contemplated one, the best judgment must be exercised.

The writer has found that the horizontal type of antennas are preferable to the vertical types. In one particular case, it was found that a horizontal 30-foot wire of the T type would bring in stations 200 miles away with several times the intensity possible with a vertical wire of the same dimensions.

A few of us may be located quite near a large broadcast station operating on the broadcast band and may have difficulty in tuning it out. A simple but effective cure for this interference is a wave trap. The trap is simply a coil and a variable condenser which will tune to the wavelength of the broadcast station. It is connected in the aerial lead-in wire. A suitable coil which will tune over the entire broadcast wave band consists of 40 turns of No. 22 wire wound on a coil three inches in diameter. The condenser may be any variable condenser of about .0005 mf. (23 plates). Figure 4 shows how the wave trap is made and

connected in the aerial lead-in. All that is necessary is to tune the condenser slowly while listening to the receiver. At one point the broadcast station will either disappear entirely, or nearly so.

To return to the construction of antenna systems, in Fig. 5 we find two illustrations of a typical aerial installation. At the left is shown how NOT to do it and at the right is illustrated the correct way. It will be noticed that the correct aerial is kept clear of all obstructions and that the lead-in is removed from the building. The aerial wire should be suspended as far away from nearby electric light and power wires as possible. If it is practical, the wire should be run in a direction at right angles to such wires, also those of trolley lines, electric railways, etc., from which electrical disturbances might be picked up. In this case the lead-in should be taken off the end furthest from the source of the disturbance.

We must also be careful to keep the aerial away from metal roofs, gutters, leaders, steel framework, etc., since these grounded objects absorb the radio energy and leave very little for the antenna.

### THE LEAD-IN

As we explained in Fig. 5, the lead-in wire should be kept some distance from the wall of the building. It must never be allowed to touch the metal cornice or leader at the edge of the roof, for these are grounded. It is a good plan to bring the aerial wire directly into the set. In this way, no difficulty is encountered with connections becoming loose or corroded. Figure 6 shows a method of bringing the wire down at the lead-in end without making a joint.

Two systems for bringing the lead-in wire into the building are commonly employed. The simplest way is to bring it through the nearest window, using a special insulated lead-in strip which is sold for the purpose. These strips consist of a flat conductor about 1/2 inch wide covered with a flexible insulating covering. The strip is placed under the window so that it will close. The end of the lead-in is connected to the outside terminal and a wire is connected to the inside terminal for the purpose of connecting to the set. It is well to solder the two wires to this strip to prevent corrosion from increasing the resistance of the aerial. This method is illustrated in Fig. 7.

The other method that is used to carry the lead-in into the building consists of a hollow porcelain bushing similar to those used for certain types of electrical wiring. A hole is drilled through the wall, slanting down to the outside, as we can see by referring to Fig. 8. The purpose of this down slant is to prevent rain water from entering the tube. The lead-in wire is passed through this tube and is connected directly to the set. Of course, in brick buildings the latter method is rather difficult, so the window strip is more commonly used. Another method is that described by Mr. H. Gernsback, which involves the use of two small copper foil leaves glued opposite each other on the window glass.

### THE GROUND CONNECTION

For both the aerial wire and the ground lead, a wire not less than No. 14 should be used. In order to get good results, we must

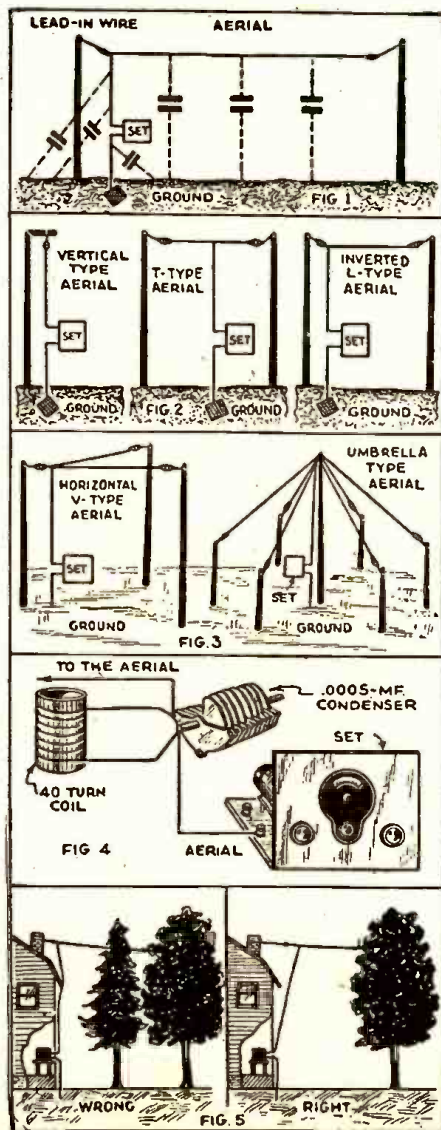

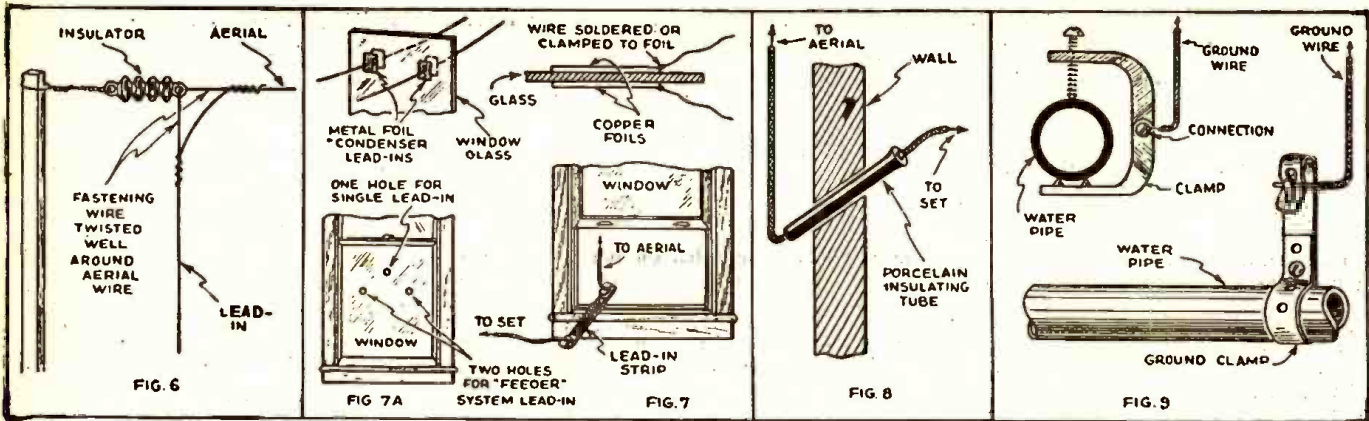

keep the resistance of the antenna system as low as possible. It is a good plan to use enameled wire so that the wire will not become corroded, as this would cause an increase in the resistance.

The ground connection should provide an electrical connection of as low a resistance as possible to the earth, since the earth acts as one of the large plates formed by the antenna system. We can easily understand that if the ground is not good, the aerial is not good either. The importance of a good ground connection cannot be too strongly emphasized.

A water pipe which forms part of a water supply system installed in the ground usually makes an excellent ground, since the pipe makes a direct contact with the earth for a long distance. It is well to note that the

water pipe grounds are approved by the Board of Fire Underwriters, as they are usually more efficient than the average artificial or homemade ground connections.

In making the connection between the ground wire and the pipe, it is advisable to use a ground clamp, as a wire wrapped around the pipe may become corroded and a poor connection will result. A ground wire connected to a simple strap-type ground clamp is shown at the left of Fig. 9. In order that we may be sure of a good connection, it is necessary to file or sandpaper any paint or rust from the pipe. Another type of clamp that is tightened by a screw to the pipe is shown at the right of the illustration.

When it is not possible to use the water pipe, in places where the water is not piped

to the house, a copper plate, a bucket or other large metal object may be sunk in a well or cistern.

Another way is to bury a copper plate about two feet square in moist earth. In general, the greater the number of well grounded objects that we can connect to the ground lead, the better will be the reception, especially on the very short waves. This difference may not be noticed on the nearby stations, but it will be noticed in the reception of distant stations.

In rural and suburban locations where lightning may easily strike the aerial, due to no high trees or buildings being around, it is advisable to use a lightning arrester, which will bypass the lightning to the ground and prevent it from going into house and through the radio.

## Constructing a Practical Short-wave Antenna

By AUDIE ROBERSON

IN past years the short wave addition to most radio sets has proved little more than a selling point and an extra expense to the public, for it is doubtful if 85% of the owners of such sets utilize the short-wave band of their sets. In fact, of all the persons I know in my vicinity who have sets that should be able to bring in foreign broadcasts, not one of them uses his set for that purpose.

A salesman's suggestion that it wasn't necessary to have any antenna at all was, I think, responsible for this condition. Since the majority of listeners had not been used to the very interesting pleasure of bringing in foreign broadcasts, they made feeble attempts to tune in on the short-wave bands and, finding the results very erratic, finally abandoned the idea of short-wave reception.

It can not be too strongly emphasized that with the average radio it is very necessary to have a good outside antenna to receive foreign short-wave broadcasts consistently.

A good single-wire antenna, as illustrated in Fig. 1, appears to be the most practical antenna for the average listener because it is inexpensive and easy to install. It has no noise-reducing qualities, but owing to its greater pick-up ability over short indoor antennas it will offer much greater signal-to-noise ratio.

This antenna is peaked for the 25-meter band.

Where it is necessary to use an antenna of the noise-reducing type, I generally recommend the one shown in Fig. 2. This con-

sists of two antennas, the flat tops made as shown in Fig. 1, but instead of having a single wire lead-in the lead-in is transposed or made of a twisted pair. This will bring the signal down through the noise zone to the radio set without picking up the noise, whereas the single wire lead-in will pick up all signals just the same as the flat top.

This antenna, as that of Fig. 1, is peaked at 25 meters, but it will be more efficient at that wave length because the lead-in will not affect the wave length. The reason for selecting 25 meters for this system is that a half-meter antenna for 25 meters will be

only 41 feet long, making it easier to install.

By peaking at 25 meters and connecting the transposed lead-in as shown it will broaden the peak and make it fairly efficient at the 49 and 12 meter bands. This gives a fair coverage of all the more important foreign short-wave broadcast stations.

It is not the writer's intention to claim the antennas described to be the best all-wave antennas, but rather to offer a compromise between the best and none at all; suitable antennas that will give good results and are not too hard or too complicated to erect.

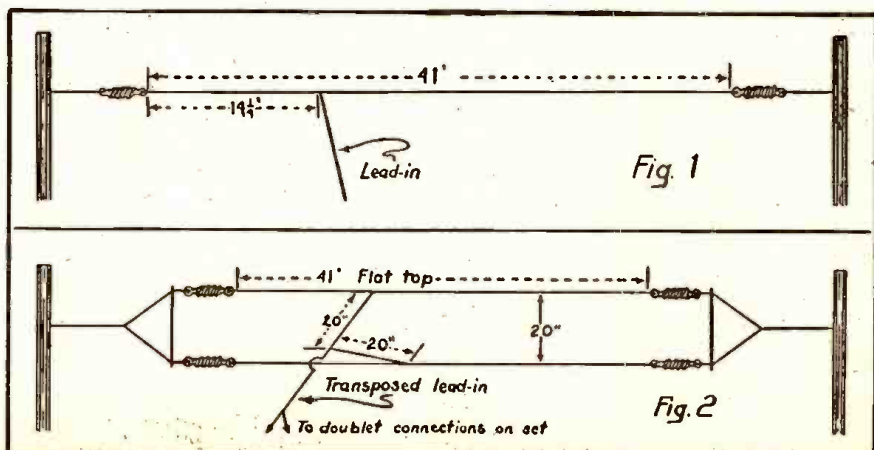

# Tuning Up Your Radio For Fall

By T. R. KENNEDY, JR.

**T**HERE are a number of very good reasons why ailing radios—or any receiver for that matter—should be inspected and overhauled now to be ready for the coming wartime broadcast season. There may be scarcities of vacuum tubes and replacement parts, even of competent servicemen. Undoubtedly the recent humid summer weather corroded antenna wires and lead-ins. The receiver itself may have absorbed moisture, rendering it less efficient. Trouble, radio men point out, never cures itself, and receiver ailments have a way of “multiplying fast” if they go unchecked.

Pointing out that all set owners should regard it “a patriotic duty” to keep home outfits functioning properly, radio experts have outlined a number of tests that can be made safely by inexperienced “home technicians.” Noise may result when a single vacuum tube is not making good contact

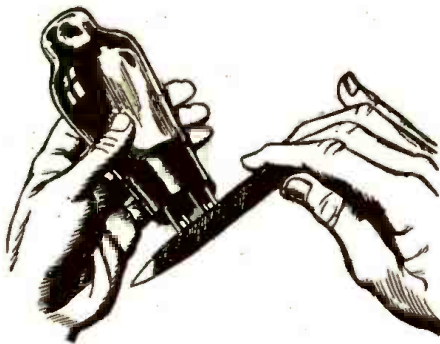

in its socket. So home mechanics are advised to remove the tubes, one by one, and polish with a nail file each metal connection or “prong” projecting from their bases.

Then replace the tubes, adjust the set to a “silent” spot on the dial, turn up the volume and thump each tube with the finger. If a tube causes a “bong” or ringing sound when thumped it is “microphonic” and should be

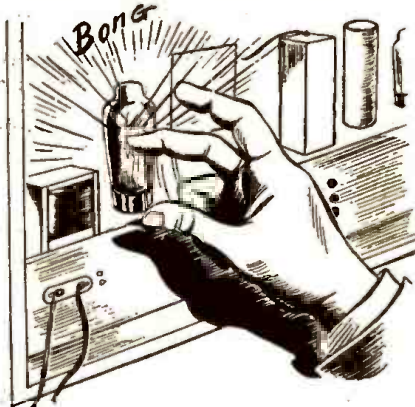

replaced, or noted for possible failure. Noise, however, may still be caused by weak or defective socket contactors. Tilt each tube gently from side to side after it has been replaced in its socket. If a grating sound is heard the socket is defective and should be replaced by a competent serviceman.

## CLEAN THE CABINET INSIDE

Behind the volume-control knobs of receivers are gadgets that often contribute noise. The set owner sometimes can remedy

such trouble without calling in a serviceman. Turn the receiver off and rapidly rotate the knob a dozen or more times. If reception is benefited try it again and again.

Incidentally, when the general inspection of the set is being made, thoroughly “dust” the interior of the cabinet with a small

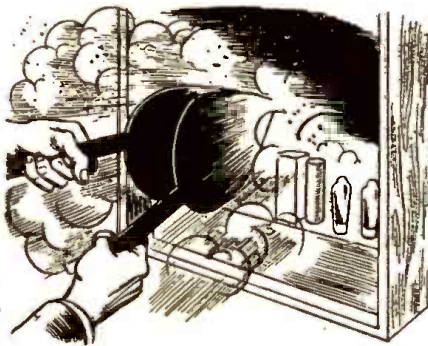

vacuum cleaner or old-fashioned bellows. Remove all deposits from exposed leaves of the tuning condenser with a tobacco pipe cleaner, being careful not to bend the plates. Inspect and polish the prongs of the chassis connector attached to the cable from the loudspeaker. Extreme care should be used in cleaning the speaker cone. Gentle pressure of the fingers against the rear surface of the delicate parchment of the cone will determine if all moving parts have the required freedom of operation.

Lift one side of the radio cabinet an inch

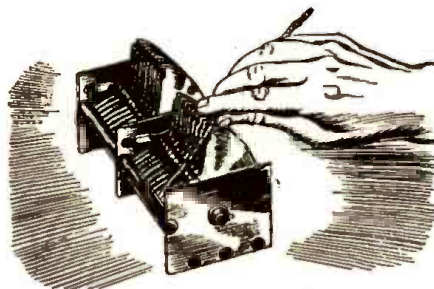

and thump it down on floor or table. If this produces a pronounced rattle when the receiver is operating, a poor circuit connection is indicated which, obviously, should be found and remedied.

An anxiety in radio is that reception can never be better than the ability of its antenna system to pluck clear signals from space. If the set is designed to operate with an outside or long antenna wire it will not function properly without it. When inspecting the roof antenna—it should be done at least once a year, preferably every six months—carefully check the entire wire for electrical continuity. Untape all joints to see if they are soldered. Ordinary wrapped-wire joints should never be tolerated—sooner or later they become noisy. Clean the insulators—install new ones, and new wire, too, if there is any doubt about their worth. Lead-in wires should be at least a foot from other lead-ins, and not touch metal roof parts. Window-sill lead-in connectors should be inspected often.

## WHAT NOT TO DO

It goes without saying that the whole

antenna structure should be sturdy and shipshape. To make sure the antenna is not contributing noise, turn the set on, have some one listen to it, then go to the roof and thoroughly shake every part of the wire system. Do it with a dry wooden stick.

Some cardinal “don’ts” have been suggested for the general wartime care of the radio. They are:

Don’t install the set in or near an open window; if it isn’t ruined by rain it may annoy the neighbors.

Don’t place the radio on a radiator; the added heat may cause a transformer to burn out, warp the cabinet or the speaker.

Don’t permit children to play where they may accidentally touch the “works” of open-back radios.

Don’t operate a noisy set as it obviously needs attention, for noise *always* indicates trouble, which progressively gets worse.

Don’t store a receiver in a damp room

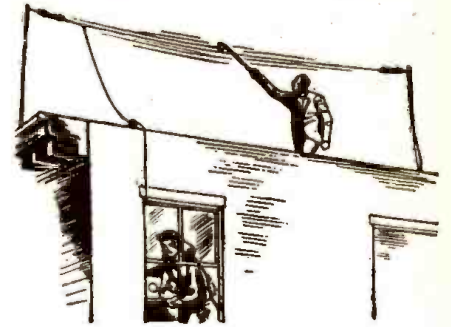

any longer than you would a good piano.

Don’t connect a radio to any home lighting circuit until you are sure it is correct for your “kind” of current; ask the landlord or phone the lighting company first.

Don’t blame a pushbutton radio for not tuning in stations clearly after a spell of weather; dampness may have changed its tuning adjustments.

Don’t operate a set without a pilot lamp; you may not know when it is turned on or off.

Don’t fail to be considerate of the receiver; in these times it pays.—*The New York Times*.

## EFFECT OF THE CABINET MATERIAL ON THE PERFORMANCE OF A RADIO RECEIVER

It is well known that the performance of a receiver is affected to a great extent by the cabinet material. Unfortunately, however, no data are available to give the effect of cabinet material and shape on the reproduction. In order to determine the probability of the influence of the cabinet, a statistical study was made of the different types of wood and bakelite cabinets of the same size and shape on the performance of a standard radio receiver. The data obtained were then utilized to derive information about the effect of these materials on the performance.

It was found from fifty tests that wooden cabinets improve the apparent signal-to-noise ratio, as higher frequencies are absorbed more than the lower ones. This effect is more pronounced if wood is of the plywood type than if it is of ordinary timber.

—*Science & Culture, India.*

**NEW RCA LABORATORIES DEDICATED**

(Continued from page 89)

the trenches on the battlefields. The work they will do will be military secrets, carefully guarded against leakage or intrusion."

On farmland that saw history made in the Revolutionary War, ground was broken for the Laboratories, August 8, 1941. On November 15 of that year—three weeks before Pearl Harbor—the cornerstone was laid, dedicating the project to increase the usefulness of radio and electronics to the nation, to the public and to industry. Less than a year later, in September, 1942, the construction workers left the scene and the research scientists and engineers began to move in, to kindle what the poets call the "divine fire" of the imagination. To the scientists of RCA, these Laboratories are the Utopia about which they have dreamt.

Among the men who work in these laboratories are those who invented the *Iconoscope* and the *Kinescope*, the "eyes" that made television practical; the men who built the RCA *Electron Microscope*, the electron multiplier tube, radio and electronic tubes for the home, for aircraft, for battle fleets and merchant marine. Now in these laboratories, with facilities for research unsurpassed, they will aim to outdo the miracles of the past.

A tour of RCA Laboratories reveals their size, magnificence, and efficiency. It is not only a radio laboratory, but many laboratories, which reveal that modern radio is a science spreading into many fields—electronics, sound-acoustics, chemistry, physics, mechanics, and optics; cathode-ray tubes, fluorescent materials, lenses and photography.

The Laboratories building is a three-story structure with long corridors into which open 150 laboratory bays. The basement is the nerve center, with its arteries of conduits and pipes, carrying electric power, gas and water supply. Alongside huge water tanks and air-conditioning apparatus are transformers and vault-enclosed power regulators; while compressed air and steam is supplied from the heating plant. Two 300-foot wells supply 600 gallons of water per minute.

Vertical shafts, 104 of them, rise from basement to penthouse, with outlets on each floor. From these, wires and pipes carry the vital services to 420 workbenches.

The total length of a corridor from end to end is 488 feet. The doors, on both sides of these spacious hallways, open into the many laboratory bays, and to nine administrative research offices and workshops. On the main floor, the general office section is near the entrance. Executive offices are located in a section on the third floor.

A visitor would be impressed with the spaciousness and broad daylight exposure, supplemented by modern indirect lighting, which casts no shadows. The work benches are so designed and arranged as to be a joy to any worker. A wiring-trough extends along the top of each bench, and the markings on the panel outlets indicate the many kinds of AC and DC current that are available to the experimenter. In addition are taps on the bench for air, gas and water; also hydrogen and oxygen, in the bays where they are used. And, of course, there are convenient plugs for soldering irons and other electrically-operated tools.

The many laboratory bays indicate the great variety of activity in the Laboratories. The Television Laboratory is described as "the last word in facilities for television research." Other laboratory bays are devoted to research in chemistry, especially fluores-

**HALLICRAFTERS ★ HALLICRAFTERS ★**

**LET'S ALL PITCH IN!**

WE CAN all help win this war by selling our government the communication receivers and transmitters they need quickly and in sufficient quantities.

That is the reason we are paying *highest cash prices* for used communications equipment.

When this war for the "four freedoms" is over you will undoubtedly be in the market for new equipment and by taking advantage of our offer to purchase your present equipment at highest cash prices you will be in a position to buy a new and better receiver than you now own.

Write, telephone or telegraph us description of your used communications receivers and transmitters of standard make; you will be paid cash immediately without bother or red tape. We are particularly interested in *Hallcrafters*.

We also have a store at 2335 Westwood Blvd., West Los Angeles, Calif.

**Bob Henry, W9ARA**  
**HENRY RADIO SHOP**  
BUTLER, MISSOURI



**COMPLETE STOCKS**

★ We still have large stocks of receivers; 2½ meter equipment, meters, tubes, transformers, resistors, condensers, panels, chassis, and radio parts of all sorts. We sell and rent code teaching equipment. Your orders and inquiries invited.

**"WORLD'S LARGEST DISTRIBUTOR OF COMMUNICATIONS RECEIVERS"**



cent materials; acoustics, radio facsimile, centimeter-wave transmission and reception, receiving tubes, cathode-ray tubes, transmitter tubes, under-water sound, and various activities associated with the future of radio and electronics.

The Model Shop is considered to be the most modern of its kind and the most splendidly equipped in the world. For example, the Meter Room has complete calibrating equipment, and 3,000 different meters for measuring voltage, current, temperature and speed.

The Technical Library of the Laboratories is cataloged as "complete, in the communications field."

An ultra-modern kitchen adjoins the cafeteria, which has a capacity of 180 to 200 persons.

**TROUBLE SHOOTING IN FM RECEIVERS**

(Continued from page 99)

high. The insulators should always be kept clean by wiping with a rag to remove grease and dirt which allow leakage to develop and power to be lost.

In an FM transmitter the power output remains constant and the antenna current should not change with modulation being applied, or in the absence of modulation it should not change. A change in current indicates over modulation or carrier shift due to a defective tube or circuit. In some cases the antenna current may change due to absorption of energy by the operator's body as the result of capacity between body and antenna. Staying away, so far as is practicable, from the radiator will help minimize this trouble.

**A SIMPLE AND EFFECTIVE CONDENSER TESTER**

(Continued from page 83)

**BUT I CANNOT OVER-EMPHASIZE THE DANGER OF INJURING THE MILLIAMMETER USED IN CONJUNCTION WITH THIS INSTRUMENT IF EXTREME CARE IS NOT EXERCISED!!!**

- Parts List for Simple Condenser Tester:—  
C1, C2—16-mfd./450-volt Electrolytic Filter Condensers  
L1—30-henry Filter Choke  
T1—Power Transformer; Secondaries: 350-0-350 volts at anything over 20 ma.; 5 volts at 3 amps. (preferably center-tapped)  
R1—25,000-ohm/10-watt Carbon Resistor  
R2 to R4—3500-ohm/2 or 3-watt Carbon Resistors  
SW1, SW2—S.P.S.T. Toggle Switches  
SW3, SW4—S.P.S.T. Push-button Switches  
SW5—17-position Switch (Mallory)  
**MISCELLANEOUS**  
1—17-point Switch Plate (Mallory)  
1—83 Mercury Vapor Rectifier (an 80 will suffice)  
2—RED pin jacks  
2—BLACK pin jacks  
1—Line cord and plug  
1—4-prong tube socket

**WARTIME USES OF SILVER**

Silver solder gives a joint which in many cases is actually stronger than the original metal. Silver bearings in airplanes make possible increased speed. Silver is doing many other valuable services today, even in the radio industry, as a substitute for other metals made scarce by the war program.

Long messages over telephone lines are recorded at 16 R.P.M. and played at 64 R.P.M. over long distance lines. At receiving end it is recorded at 64 R.P.M. and played at 16 R.P.M. to get message clear and distinct. This process takes only 25% of normal toll time.—*National Radio News*

# BEGINNER'S ONE-TUBE RECEIVER

By KARL E. SCHUBEL

FOR the fellow who is just starting out in radio, whether he be a teen-age youngster or a retired gentleman looking for a hobby, we present herewith the simplest one-tube receiver that can be made. (We say simplest because it starts with something that can be added to easily, or experimented with later on.)

The beginner in radio today is up against several things. He's supposed to know how to read a circuit diagram or schematic, how to tell radio-frequency from audio-frequency circuits, what power supplies are for and why they hook-up the way they do; what tube diagrams mean, what tube characteristics mean, etc. But studying theory alone, without making something to experiment with and make observations with, is pretty tough, and soon gets discouraging instead of interesting.

Twenty years ago when we made our first simple one tube radio, we wound some magnet wire around an oatmeal box and had a slider running up and down over the coil. We had a crystal detector and used the vacuum tube as an amplifier. We had an aerial on the roof and made a ground connection by clamping a wire to a water pipe.

Everybody was a beginner and diagrams were simple and easy to understand. But vacuum tubes were pretty expensive, and while we were saving up money to buy them, we read everything in sight about radio, and talked to our neighbors and fellow employees about it. We got to be pretty good in an elementary sort of way.

Today manufactured parts are available, standardized as to ratings and connections, far more efficient, and generally designed to mount on metal chassis. However, for the beginner, we think the old breadboard layout is still the best instructor.

This 1-tube *regenerative* receiver is just a little more complicated than the one the 1922 beginner started out with, because we

are jumping right into regeneration, octal-base tubes and condenser tuning.

We are using the standard octal socket because most of the present day tubes are 8-prong. We tried to find a 4-prong triode that would operate on 1.5 volts of "A" Battery, but the only triode easily available is the 1-G4, which has an 8-prong base. We don't think you'll have any trouble, for only four of the prongs must have wires connected to them.

This tube is called a *triode* because it has three elements, namely the plate, the grid and the filament. The battery which lights the filament is called the "A" Battery. The battery which is connected between the headphones and "A"-minus, is called the "B" Battery. We say that the plate, the tickler coil, the headphones and the B-battery are in "series." The tuning condenser and the secondary of the tuning coil are in "parallel." One "side" of each of these two circuits are connected at a common point, called the "ground" or B-minus. Ground also means connecting to the water-pipe, or if a metal chassis is used, soldering or bolting down a wire right on the chassis metal. This may seem a little confusing at first but it will clear up as you build sets and get familiar with circuits and radio theory.

Extreme caution must always be exercised in hooking up the batteries. The B-battery is always larger and if hooked up wrong will burn out the tube!

Rule: Always connect the positive (+) or "plus" terminal of a B-battery to the earphones (or B-plus terminal of an audio-frequency transformer, which you will learn about later). The negative (-) or B-minus terminal is hooked up by a wire to the negative or minus terminal on the A-battery. (If the A-battery is of the dry-cell type, the minus or negative terminal is the one on the outside, fastened right to the metal can of the cell itself.)

The steps to be followed in building the receiver are:

1. Laying out the parts.
2. Mounting the parts.
3. Wiring up the parts (See Fig. 1).
4. Hooking up the batteries (See Fig. 8).
5. Making the aerial connection and ground connection.

## LAYING OUT THE PARTS

Study each coil and condenser as you remove it from its box, noting the number of terminals, and whether you can put a wire on by bending it around a screw or whether a lug is provided for the wire to be soldered to. In the case of the bypass condenser this may be mica (postage-stamp type) or tubular (cartridge type).

If you are using the breadboard layout, you will make a front panel of masonite or plywood, or a piece of aluminum, about 10 inches long by 7 inches high. The base can be 10 inches long by 8 inches wide. This gives plenty of space to work in.

Before drilling holes in the front panel, place the tuning coil and the tuning condenser up against the back of the front panel and shift them about, to see where they should be mounted without interfering with each other, and still give a symmetrical appearance, with convenient spacing for making connections. Mark with a pencil or sharp point on final centers selected, and drill the holes. The holes usually are about 5/16 inches in diameter (for 1/4 inch shafts).

## MOUNTING THE PARTS

Fasten the front panel onto the base, and mount the tuning condenser and tuning coil. Mount the octal socket on the base, using 3/4-inch spacers (1/4-inch diameter pieces of iron or brass tubing).

Next mount the Fahnestock clips, spacing them in such a way that they can be identified easily. Mark with a pencil right on the base, in front of each Fahnestock clip what it is—A+, A-, etc.

## WIRING UP THE PARTS

The beginner may use bell-wire, or hook-up wire, to connect up the wires (or leads, as they are called) to the different terminals, either by bending them around, or by soldering. Soldering is to be preferred, as it makes smaller and better connections, and also gives you practice in using the iron. Run the leads as directly as possible and yet keep them apart: If grid and plate leads have to cross, try to make them do so at right angles.

## HOOKING UP THE BATTERIES

Follow the diagram and the perspective drawing carefully, making sure to hook up the A-minus terminal to the B-minus terminal, either at the batteries or on the B-minus-and-ground-line on the base. (The ground or B-minus is so many other wires connected to it that some constructors run a piece of bare wire the length of the set and make connections directly to it).

## AERIAL AND GROUND

For an aerial you should try 40 to 75 feet of stranded wire, mounted on the roof, with insulators on each end, and so hung that it touches nothing. Connect up a lead-in of

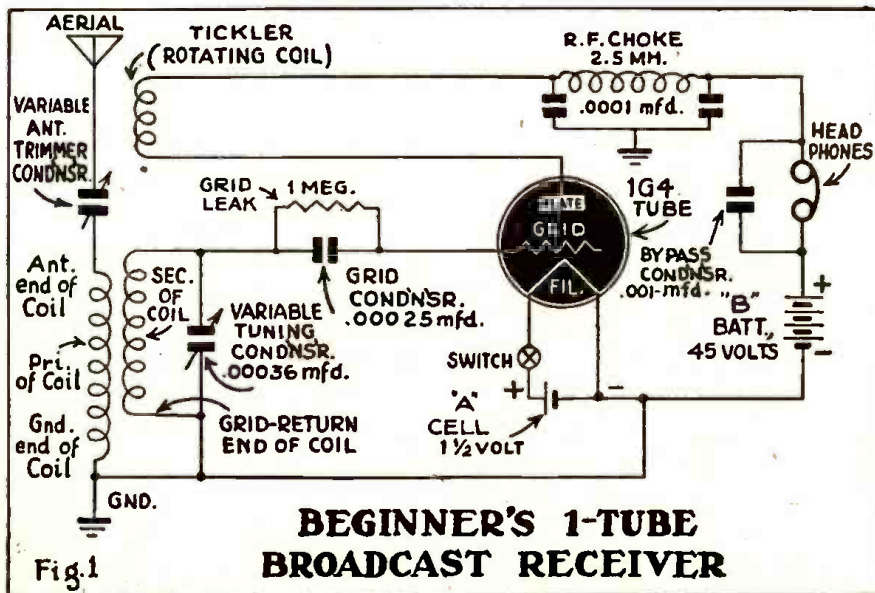

rubber-covered wire, and run it down to window of room where set is located. Use an insulated flat metal strip to pass under the window, and then a piece of wire from the strip to the "Ant." terminal on the receiver.

For a ground, run a piece of wire from the "Gnd." terminal on the set, to a water pipe. Use an electrician's ground-clamp around the pipe and hook the wire to the clamp. This gives a good quiet connection.

**PUTTING SET INTO OPERATION**

When all the above steps have been followed, connect up the head phones and turn on the switch. Turn the tuning condenser knob. You may hear hisses, squeals or howls, or you may happen to get a station clear. Turn tickler knob to right and left until you see which way you produce squeals and howls (which is evidence of regeneration). You will soon get the knack of getting a station, and bringing it in clearly, with maximum volume without noise.

It may be found that two 45-volt B-batteries (90 volts) will be needed instead of just one. If so, do not hesitate to buy it, as you can use 90 volts for later experiments and circuits.

**LIST OF PARTS**

- 1 Ant. trimmer condenser, 3-30 mmfd.
- 1 tuner with tickler
- 1 Grid leak resistor, 1 or 2 megohms
- 1 Grid leak condenser, .00025 mfd.
- 1 Tuning condenser, 0.00036 mfd.
- 1 1G4-G tube

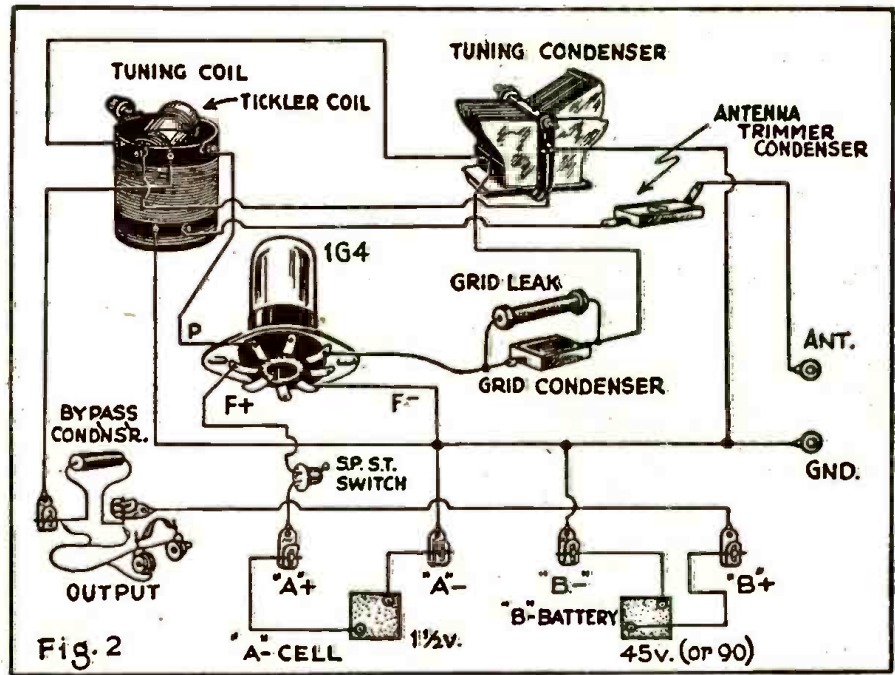

- 1 2.5 milli-henry choke
- 2 Mica condensers, .0001 mfd.
- 1 Bypass condenser, .001 mfd.
- 1 Pair headphones.
- 1 45-volt B-battery

- 1 1½-volt A-battery
- 1 octal tube socket
- 1 S.P.S.T. switch
- 1 knob for tickler shaft
- 1 Dial and knob for tuning condenser

**SCIENCE AND SOUND**

By STANLEY DOWGIALA

You can actually see sound in action! If you want to prove this for yourself, try the following experiment:

Remove the top from an empty oatmeal box and stretch a sheet of rubber from a toy balloon over the opening. Fasten this rubber sheet to the box with a string or a rubber band. About halfway down the side of the box cut a hole about one or two inches in diameter.

Then roll a sheet of heavy paper or cardboard into the form of a tube about one foot long and two inches in diameter.

Now stand the oatmeal box upright and sprinkle a little dry sand over the sheet of rubber just enough to cover it with one layer. (Colored sand is better and gives off technicolor effects). Hold one end of the tube near the hole in the oatmeal box and whistle or hum through it softly. Be careful not to blow directly into the box. Almost immediately the grains of sand will bounce about rapidly and arrange themselves into a design.

Next try another sound, such as snapping your fingers or speaking a word. The grains of sand will again hop about but

this time they will form a different pattern. If you continue using a new sound each time you blow into the tube, you will notice that the sand forms a distinct design for each one. The reason for this is easy to understand. Sound, the scientists say, is caused by vibrations of the air. Each sound has its own set of vibrations, which is different from any other set. Therefore when these vibrations put the grains of sand on top of the oatmeal box in motion, they make them bounce about in a manner that is different for each sound. Thus, we might say that a sound "takes" its own picture. In your experiment, try as many kinds of sounds as you can think of.

**ERROR-PROOF RADIO PRINTER**

ALL possibility of error from defective signals in radio-telegraph transmission is eliminated by a new error-proof radio printer put into operation in the international communications field recently on the direct radio circuit of R.C.A. Communications, Inc., between New York and Buenos Aires. Product of RCA Laboratories, the new printer works with brain-like facility. It automatically rejects false signals and prints an asterisk in place of an incorrect letter.

Present secrecy restrictions necessitated by the war prevent a full description of the printer. RCA Communications officials say that it could be revealed, however, that the device operates with a special code so constructed that a defective character is immediately recognized as such by the printer.

**SPECIAL**

The books listed below have never been sold by us before. The value of each book is 50c. They are exactly the same as RADIO & TELEVISION'S 50c blue books which have been on the market for years.

For a short time only we are selling these at a special reduced price of only 75c for the 3 books. All of the books contain numerous photographic illustrations and diagrams and have stiff flexible cover.

**ABC OF TELEVISION**  
Contains latest material on television developments. It covers theory of scanning; simple television receiver; how the eye sees; neon lamps; electric cell; neon lamps; need for broad channel width in transmission of high-fidelity television signals; cathode ray tube and television receivers; Patheview system of television transmission; and other important features.

**SHORT WAVE GUIDE**  
Covers hundreds of short-wave questions and answers; illustrates popular short-wave links; gives explicit instructions for building simple short-wave receivers; instruction on the best type of antenna installation; diagram and construction details for building transmitters.

**S. W. RADIO QUIZ BOOK**  
This book covers questions and answers on transmitters, ultra short-wave receivers, practical short-wave receivers; practical winding data; novel coil hook-ups for experimenters; how to "hook-up" converters, noise silencers, beat frequency modulators, preselectors, antennas, preselectors, 5-meter receivers.

**RADIO & TELEVISION**  
25 W. Broadway,  
New York, N. Y.

Gentlemen:  
Enclosed you will find remittance for 75c (cash, new U. S. stamps or money order accepted) for which please send me at once your 3 books  
**ABC OF TELEVISION    SHORT WAVE GUIDE    SHORT WAVE RADIO QUIZ BOOK**  
PLEASE PRINT CLEARLY

Name .....  
Address .....  
City ..... State ..... RC-11-42

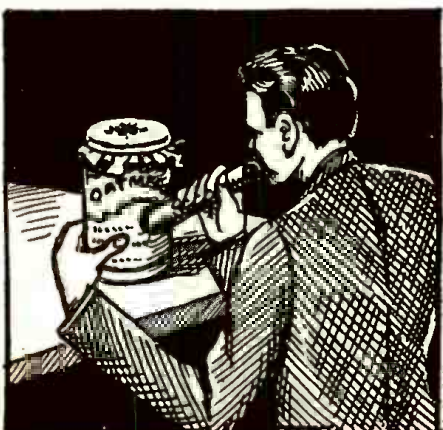

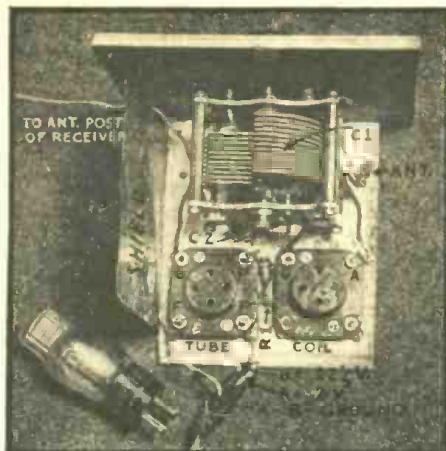
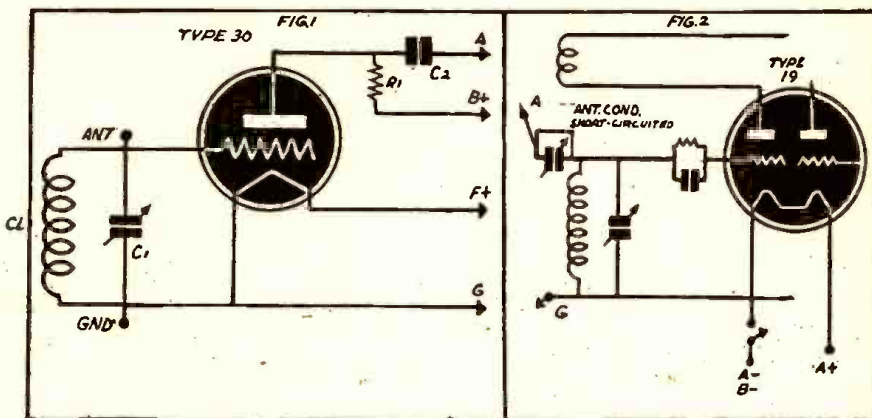

Photo shows pre-amplifier alone, with parts arranged in position for best operation.



Simple circuit diagrams of the R.F. pre-amplifier and a detector stage with antennae switching arrangement.

# AN R. F. PRE-AMPLIFIER FOR BEGINNERS

By BOB WHITE

HERE is my diagram of a 1-stage R.F. pre-amplifier (Fig. 1) which is quite simple to construct and operate and yet is highly efficient in performance. I am sending it in hopes that some of your young readers will find it interesting. This pre-amplifier has been used on all wave lengths from 585 to approximately 20 meters, with a broadcast-band tuning condenser.

The receiver shown in the photograph, working alone, without pre-amplifier or extra amplification, has explored all the bands between 14 and 585 meters. It uses a broadcast-band condenser unit with which it has picked up South America, Italy, New York, England, Australia, and many other stations. Its initial difficulties were that it had not enough power to bring in distant short wave stations on a loud speaker, and not enough power to bring in distance on the broadcast band. These problems were cured by adding an audio amplifier, giving it 3 stages of audio (enough power to work a 10-inch PM speaker), and by adding a 1-stage R.F. pre-amplifier, which gave the set enough power to bring in Mexican stations on the broadcast band any time of the day or night. These three units operate on 2 45-volt B batteries, and 2 large No. 6 dry cells with a 15-ohm rheostat. The wiring of the pre-amplifier is very simple and it will easily double the performance of any receiver.

Tuning this small but efficient pre-amplifier takes but little practice, as it is very easy to operate.

### TUNING SHORT-WAVE STATION

Set detector-tuner at approximate wave length desired.

Tune pre-amplifier knob until, rushing noise is heard.

Tune detector for station.

If rushing stops at a certain place even though there is plenty of condenser yet to tune, the regeneration on the receiver has given out, more turns must be added to the tickler coil or a higher voltage put on the plate of the detector.

### TUNING LONG-WAVE STATION

Set detector-tuner near dial position where reception is desired.

Tune pre-amplifier until squeal, rushing, or station is heard.

Readjust detector-tuner until squeal is at its lowest tone, or station is at its loudest. Then take away hand to test for capacity, and readjust pre-amplifier once more for perfect reception.

If squealing continues reduce regeneration control.

If distortion occurs it is caused by over-regeneration, so reduce regeneration control until clear signal is heard.

### ANTENNA AND GROUND

The antenna consists of a piece of wire 3 ft long. The ground, which is optional, is attached to a cold water pipe, or directly to the ground. In some cases better results are obtained by not using a ground. The antenna and ground may be eliminated by using plug-in loops instead of plug-in coils. With a loop the set becomes very direc-

tional, and may be used as a station locator.

### HOW TO ATTACH THE PRE-AMPLIFIER TO A RECEIVER

Hook lead A to the antenna post of a 1 or 2 tube battery receiver.

Hook lead F to A+ on receiver if it takes from 1½ to 3 volts on the filament. If it has a higher voltage, a filament resistor will have to be used.

Hook lead B to 22½ volt tap of the receivers "B" battery.

Hook lead G to A- B- (GND) on receiver.

### Parts List

- C1—Broadcast Tuner Cond.
- C2—.002 MF Fixed Cond.
- R1—6000 OHM Fixed Resistor
- CL1—Grid Coil or Loop (as shown between Ant. and Gnd. in Fig. 1)

Here is the complete array of units neat and compact and "ready to go."

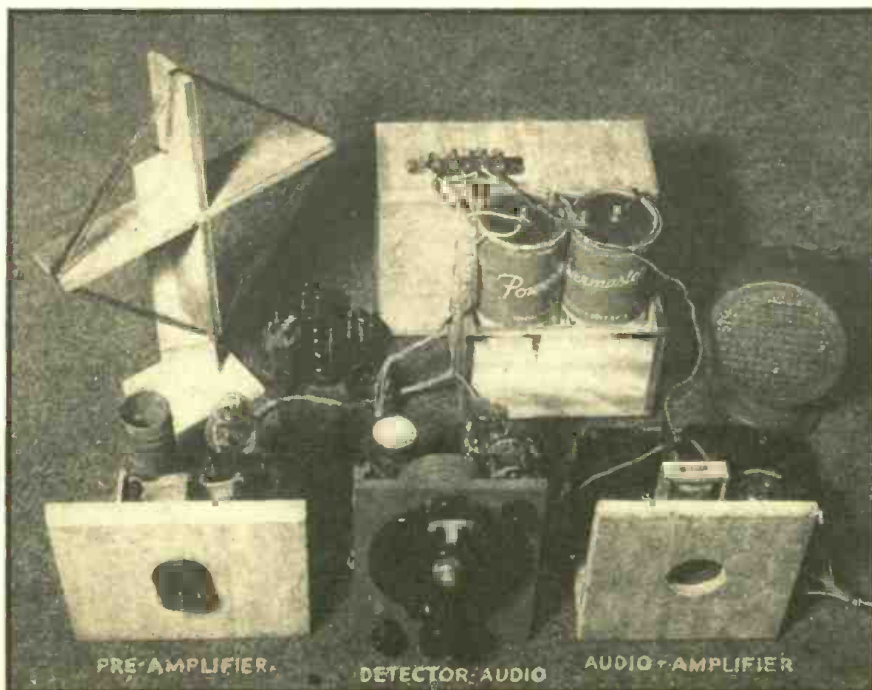



# HOW TO CONSTRUCT A TUBE CHECKER

By E. POTTRUFF

The tube checker shown in the accompanying diagram is relatively easy to operate. The cost of construction is very low; yet it furnishes free floating filament and cathode connections. It will be understood by the constructor that the sockets shown blank can be hooked up to the proper connection numbers.

It provides the following services:

1. Tests filament continuity.
2. Shorts, hot or cold (and if desired, which element has the short).
3. Automatically furnishes short test, before emission test can be taken.
4. Emission test with all elements tied together.

The circuits from all elements are brought out to banana jacks and continue to the

400 ohm resistor with a shorting switch is connected in series with the meter to be used when testing such tubes as the 6H6, so as not to damage the tube, but the difference in emission current must be marked on the chart or tube manual.

For example, to test a type 6K7 tube—close all circuit switches except Nos. 2 and 7. Adjust the filament tap FS to 6.3 volts. Plug one jumper between jack B and No. 7. If cold short exists from filament, neon bulb will glow. Plug A to jack No. 2. This heats the filament. If no short shows, open circuit switch 8 and plug jack B to cathode jack No. 8. If a short shows it is only necessary to open each circuit switch in turn to find out which element causes the short. Finally press switch "T" which gives the emission check.

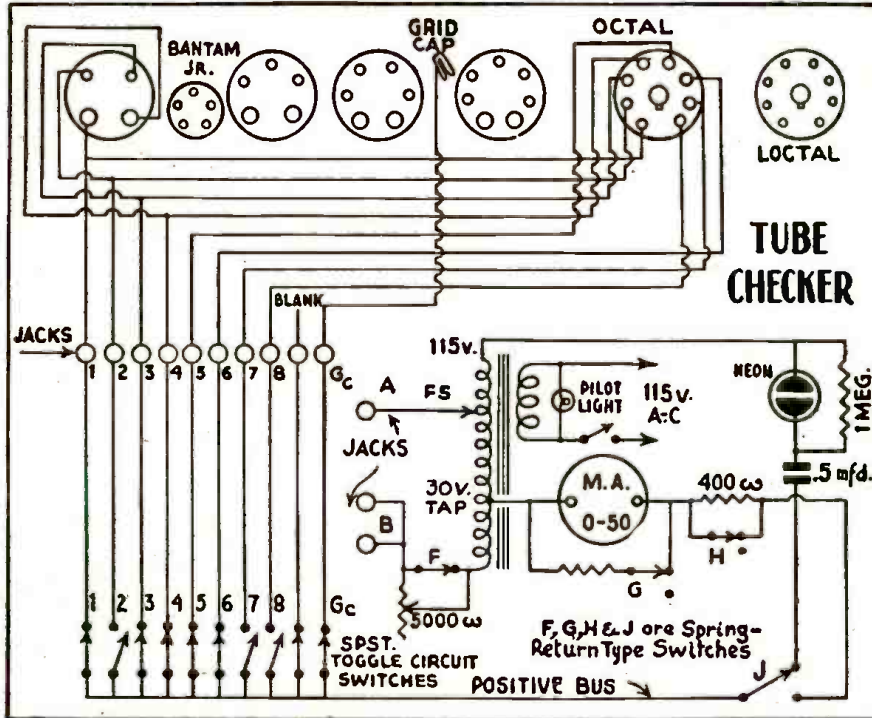

Simple circuit diagram of tube checker for all type tubes.

positive bus bar, being interrupted to the latter by individual S.P.S.T. toggle switches. Three banana jacks are connected as shown to the filament transformer. The filament and cathode connections are set up as required by three flexible wire jumpers with plugs. This action is more deliberate than circuit switches and tends to eliminate the possibility of a wrong setup and shorts in so doing. A 5000 ohm variable resistance can be switched in on one side of the filament to lower the 1.5 volt tap to that required for hearing aid tubes. A multiplier shunt is held in the circuit across the milliammeter by a spring return switch. This guarantees protection for the meter in the case of rectifiers and mercury vapor tubes. In the case of other tubes this switch is pressed to obtain low scale. The emission test switch "T" is also spring return and keeps the positive bus connected to the neon bulb so as to give the short test first. Pressing this switch gives the emission test. A

Ballast tubes can be checked for continuity by opening the requisite circuit switch and plugging B to the jack on the same circuit. If OK the neon bulb will glow.

In the case of testing the filament type tubes it is not necessary to use the cathode jumper, as the negative side of the transformer is already connected when the filament connection is made.

Care must be taken when testing tubes with tapped filaments (pilot light connection) to open the circuit switch connecting the tap, before the tube is plugged in.

Of course the tube base chart or tube manual must be used with this tester. There are so many new tubes on the market that this book must be used in every case.

No provision was made for line voltage adjustments, as the variation shown on the milliammeter will not be so great as the case when a "BAD-?-GOOD" meter is used with its accompanying shunts.



**Readrite**  
**RANGER**  
MODEL 432-A

The Outstanding Tube Tester Value . . . .  
Checks all type tubes including Loctals, Bantam Jr., 1.4 volt Miniatures, Gaseous Rectifier, Ballast, High Voltage Series, etc. Filament Voltages from 1.1 to 110 volts. Direct Reading GOOD-BAD Meter Scale. Professional-appearing case with accessory compartment large enough for carrying Model 739 AC-DC Pocket Volt-Ohm-Milliammeter, thereby giving the serviceman complete testing facilities for calls in the field. . . . Model 432-A with compartment. Dealer Net Price . . . \$20.73. Model 432-A in case less compartment . . . \$19.65. Model 739, Dealer Net Price . . . \$10.89

Write for Catalog—Section 1116 College Drive  
**READRITE METER WORKS, Bluffton, Ohio**

## WORLD-TIME CLOCK

The Only Clock for Universal Use Throughout the Entire World!

A REGULAR CLOCK with A.M. and P.M. divided dial

A WORLD-TIME CLOCK Instantly indicating time in all 24 zones

INTERNATIONAL CLOCK with A.M. and P.M. 24 hour dial

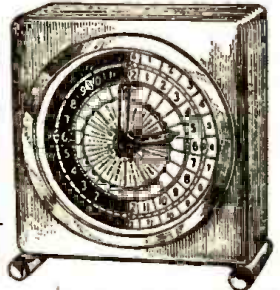

Here is really the first new clock advancement in 200 years—three clocks in one, a world-time clock. It is revolutionary! It is years ahead! The Sky Pilot WORLD-TIME CLOCK is the only clock desired for use anywhere in the world. For short-wave fans this clock offers great convenience—it is educational and at the same time indicates world time differences. In a few seconds you can determine the correct time in London, Moscow, Hawaii, Tokyo, Buenos Aires, Halifax—anywhere. American made—it is exceptionally easy to operate. It carries a guarantee of ninety days against defects in material or workmanship. In modernistic design, it is made of brushed brass—measures 5 1/4" high by 4 3/4" wide—and has convex crystal. Electric (for A.C. 110-120 volts, 60 cycles) \$9.95  
Spring Model . . . . . \$8.95

P.P. prepaid in U.S.A.  
Remit by check or money order; register letter if you send cash or unused U.S. postage stamps.  
**GOLD SHIELD PRODUCTS**  
350 Greenwich St., Dept. RC-11 New York City

## PATENTS — TRADE MARKS

Booklet concerning Inventions & Patents Form "Evidence of Conception" with instructions for use and "Schedule of Government and Attorneys Fees"—Free  
**LANCASTER, ALLWINE & ROMMEL**  
Registered Patent Attorneys  
486 Bowen Bldg. Washington, D. C.



# TARGET FOR TONIGHT

... *Your Business?*

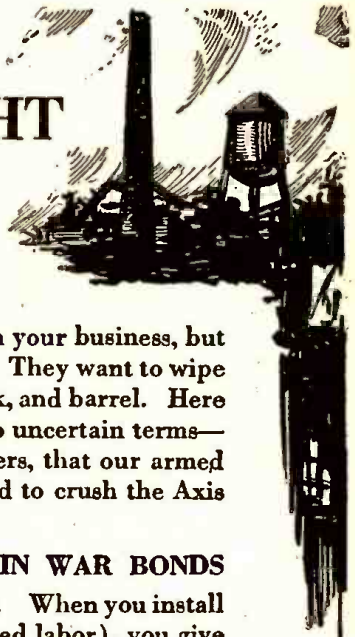

Maybe they won't actually come and drop a *bomb* on your business, but the Axis war lords have their eye on it, just the same. They want to wipe it out as a competitive force—or take it over lock, stock, and barrel. Here is a threat that you can reply to *now*, today, and in no uncertain terms—by buying War Bonds to the very limit of your powers, that our armed forces may have the guns, tanks, and planes they need to crush the Axis *once and for all*.

**THE GOAL: 10% OF EVERYONE'S INCOME IN WAR BONDS**  
 Every American wants the chance to help win this war. When you install the Pay-Roll War Savings Plan (approved by organized labor), you give your employees that chance. For details of the plan, which provides for the systematic purchase of War Bonds by voluntary pay-roll allotments, write: Treasury Department, Section S, 709 12th St. N.W., Washington, D. C.



## Buy War Savings Bonds

This space is a contribution to America's All-Out War Program by  
**RADIO-CRAFT**

# LOCATING SHORT CIRCUITS

By WILLARD MOODY

**S**UPPOSE that we have an output tube such as the 43 and no plate-voltage is obtained on the tube. Turning the receiver power off and applying the ohmmeter we find that a resistance of 400 ohms between plate and cathode is measured.

Connecting the meter between cathode and ground we get zero resistance, and between plate and screen of the 43 (plate return and screen common) we measure 100 ohms.

The resistance, obviously, is 300 ohms from plate-return to cathode, and 100 ohms from plate to screen, indicating that the "short" is from plate-return to ground on cathode.

Therefore, it only remains to disconnect the condensers between plate-return or screen to ground, to remove the short.

Since we happen to have 300 ohms from 43 screen to rectifier cathode (choke resistance) this indicates a "short" from rectifier cathode to ground. This could be caused by the first electrolytic filter condenser and, in addition, a low resistance short could be the result of cathode-to-heater short-circuit in such tubes as 25z5, 35z5, etc.

If we have an A.C.-D.C. rectifier rated 100 ma. maximum output at 100 volts, the minimum load resistance in the circuit must be dictated by the available power. A resistance of 1,000 ohms would drain too much current from the rectifier and "pull down" the available voltage. The current

would be

$$I = \frac{E}{R} = \frac{100}{1000} = .1 \text{ ampere}$$

or the maximum from the system.

If we use a 3,000 ohm shunt field (many A.C.-D.C. receivers have such arrangements) the current will be

$$I = \frac{E}{R} = \frac{100}{3000} = .033 \text{ ampere,}$$

a reasonable figure. This, then, would serve as a guide when making a resistance measurement in a circuit using the 25z5 for example.

Of course, where a shunt speaker field is not used, the resistance from 25z5 cathode to B-minus or line switch should be high—from 5000 ohms up.

Suppose that we have a 6F6 tube which normally operates with 250 volts. We find, by resistance measurement that the resistance between plate and ground is 2000 ohms. What current would be drawn through the output transformer primary?

$$I = \frac{E}{R} = \frac{250}{2000} = .125 \text{ ampere,}$$

the maximum current from a rectifier such as the 80. It is very evident that such a value of resistance would be far too low and that the tube would be shorted, or that the transformer, the filter condensers and possibly other parts which normally present a high resistance between B+ and ground

in such a D.C. system, are shorted.

If we have a diode detector with a load of 250,000 ohms and a 1 meg. resistance from the high side of this load to the I.F. grid return, then the resistance from the grid return to ground should be 1.25 megohm. If it is less than this, there is leakage in the A.V.C. by-pass condenser.

Let us assume that the leakage is 1 meg-ohm and that the D.C. leakage current normally is zero for a 10 volt drop across the 250,000 diode load. The leakage current will then be through 1 megohm of A.V.C. resistance in series with 1 megohm of condenser leakage. If the supply is 10 volts, the current will be

$$I = \frac{E}{R} = \frac{10}{2 \text{ MEG.}} = .000005 \text{ AMP.}$$

or 5 microamperes. The current in the diode load will be

$$I = \frac{E}{R} = \frac{10}{250,000} = .00004 \text{ AMP.}$$

or 40 microamperes, so that 1/5 of the current will be lost. The A.V.C. voltage may then be too low, and the set may distort on very strong signals. Where the leakage is less than 1 megohm, the distortion is more pronounced, due to excessive A.V.C. voltage loss.

Ohm's Law may be applied in many interesting ways, to see how D.C. voltage distribution operates in receiver circuits. Try it and benefit by its application.

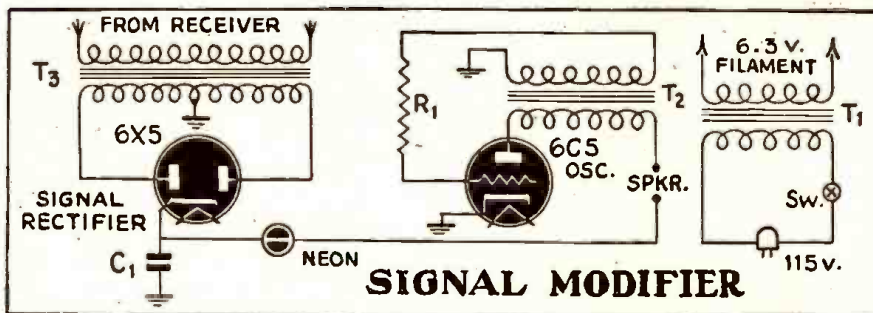
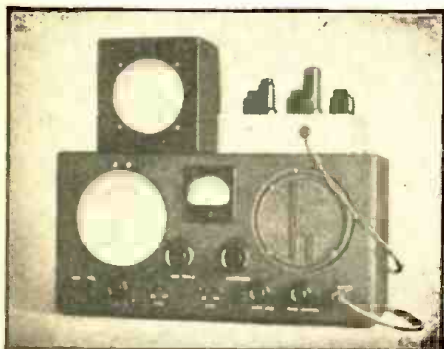

Photo shows receiver with signal modifier placed on top. Diagram shows simple circuit of this unique addition to C.W. receiver.

## A SIGNAL MODIFIER FOR RECEIVING CODE CLEARLY

By JAMES SOLMS

CODE reception is sometimes made difficult by the presence of chirps, thumps and clicks which cut down receiving speed. The Signal Modifier corrects at the receiver these faults which originate at the transmitter. Here is how the Signal Modifier works. The received code signal, having been amplified by the receiver, is first rectified and then applied to an audio-frequency-oscillator as a source of power for the oscillator plate circuit. In this way, not the signal itself, but a tone produced by an entirely separate oscillator set into operation by the action of the signal, is heard.

Chirps or key clicks have absolutely no effect on the resulting tone which is heard. Shot interference produced by ignition is eliminated and background noise is greatly reduced. Mush and hiss produced by the beat oscillator in superheterodyne receivers, noticeable especially in inexpensive sets, are reduced considerably. The value of this instrument is obvious, considering the advantages which are gained by its use. Operating on an entirely different principle, the Signal Modifier in no way resembles the Uni-Signal Selector built by Meissner or the Hetrofil designed by Millen.

The signal voltage from the audio power amplifier of a communications receiver is impressed across the primary of the step-up transformer. This transformer is a 2-to-1 push-pull input transformer. Its primary is connected to the headphone jack of the receiver. The 10,000 ohm impedance of the primary reflects the approximate impedance of the audio power output of the ordinary receiver. A potential of about 100 volts appears across the secondary and is then rectified by the rectifier tube 6X5. The output of the 6X5 is then applied to the 6C5 oscillator. This circuit has no variable controls. No external power supply is required except for the filament supply, since power for the oscillator plate is obtained directly from the audio power stage of the receiver. The unit requires about 1/2 watt of power from the receiver.

The .1 mf. condenser shown in the circuit diagram serves as a filter for the rectifier. A smaller capacity here would not adequately filter the output of the 6X5 and would make the tone produced by the 6C5 oscillator rough and unpleasant to listen to. If a larger capacity were used here, it would be impossible to copy fast signals, since all the individual dits and dahs which make up a code group would combine, allowing the oscillator to function continu-

ously. The value of the .1 mf. condenser was determined by experiment.

The accompanying graphs illustrate the purpose of the neon bulb inserted in the cathode circuit of the 6X5. On the third graph line, "A" represents the minimum striking voltage of the neon bulb, while "B" represents its minimum operating volt-

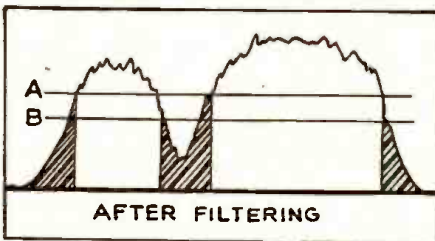

This sketch shows graphically how the use of the neon bulb cuts out chirps, hash, mush, etc.

age. No current will flow to the oscillator until the rectified signal voltage exceeds the minimum striking voltage, and no current will flow after the signal voltage falls below the minimum operating voltage. Thus, even though the spaces between signals are "filled up" by the filtering action of the .1 mf. condenser, the neon bulb cuts out this undesirable part of the rectifier output. The shaded parts of the third graph indicate the part of the rectifier output which does not pass the neon bulb and is not used by the oscillator.

As long as the noise level voltage of the receiver does not exceed the signal voltage, the volume control may be set at a certain level, such that the noise voltage is less than the ionization voltage of the neon bulb,

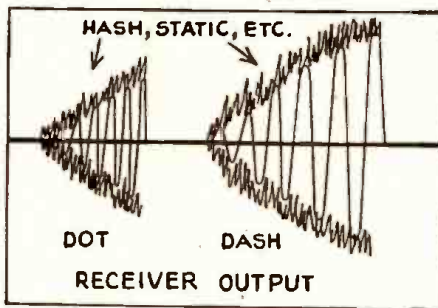

This represents code as it usually enters the detector circuit. (For usual receiver output see sketch marked "detector output.")

freeing the oscillator output from mush, hiss and ignition interference.

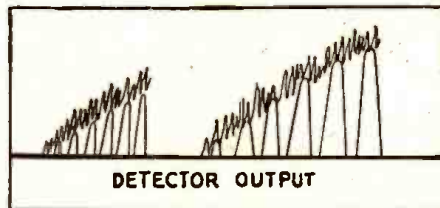

Even after detection, chirps and mush are still present in the received signal.

The value of  $R_1$  in the grid circuit of the 6C5 effects the tone produced by the oscillator. A higher value for this resistance results in an increase in the frequency of oscillation. The value of 2 megohms resulted in a pleasing note. If a transformer other than the one specified is used in place of  $T_2$ , the resulting tone may be changed and it will be necessary to experiment to find a satisfactory value for  $R_1$  to produce a pleasing tone. A small magnetic speaker is used in the output circuit of the oscillator.

In operating the Signal Modifier a definite procedure should be followed. The receiver's beat oscillator is first turned on and the pitch control adjusted until the hiss produced by the beat oscillator has the lowest pitch. A code signal is then tuned in to zero beat. The pitch control is again adjusted until the signal has a pitch of about 500

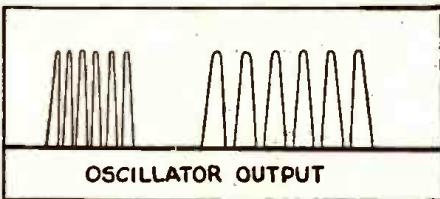

The crystal-clear signal heard when using the signal modifier.

c.p.s. After this has been done the Signal Modifier is plugged in. This procedure is made more convenient by including a switch in the circuit which can connect the speaker either directly to the receiver output or to the Signal Modifier.

The chassis measures 7 x 7 x 2 inches. The transformers across the back are  $T_1$ , the filament transformer,  $T_2$ , the oscillator transformer, and  $T_3$ , the push-pull input transformer. In front the 6C5 is on the left, the 6X5 on the right. The underchassis wiring is simple and needs no illustration. The neon bulb is mounted directly by means of wires soldered to its base.

(Continued on page 128)

# OFF THE PRESS!

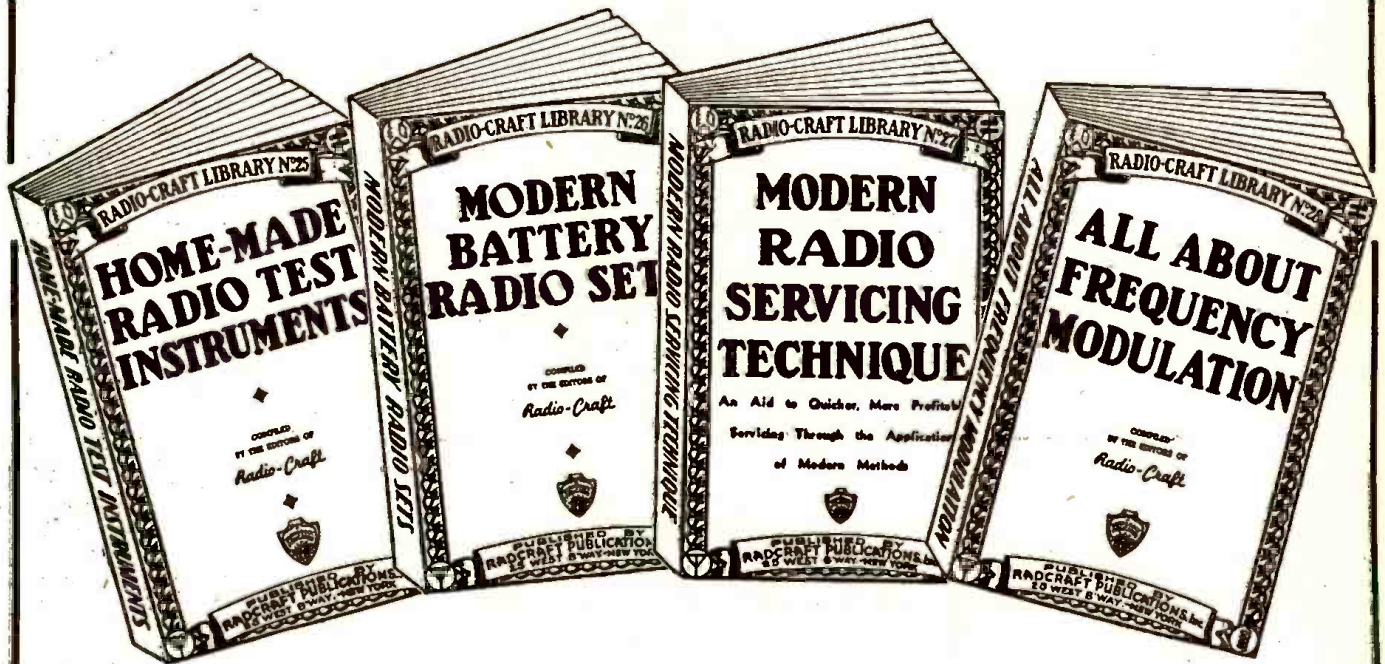

## New RADIO-CRAFT Library Books

**THE** four latest books of our well-known RADIO-CRAFT Red Books—Nos. 25, 26, 27 and 28—have just come off the press. These four books are all on timely subjects and we recommend every one of them to you strongly. Now, more than ever, radio education has become a burning question. If you are to be in the National Service; in the Army, Navy or Air Force—practical radio knowledge is of paramount importance. **YOU CAN GET BETTER RATINGS AND ADVANCE QUICKER IF YOU HAVE A GOOD RADIO BACKGROUND.** Conversely, if you are not with the armed forces, there is a whole of a job to be done at home. With more and more men going into the service, the demand for practical servicemen becomes greater each day. Therefore we say: **PROFIT BY THESE UNIQUE BOOKS, WHICH ARE PRICED SO LOW THAT THEY ARE WITHIN THE REACH OF EVERYONE'S PURSE.**

### No. 25—HOME-MADE RADIO TEST INSTRUMENTS

This book includes articles covering a wide range of test apparatus of live interest to every radio man. Servicemen will find many circuits in this book to make their work more profitable. New ideas in test equipment make it possible to service radio receivers more quickly. Laboratory workers and experimenters will find many articles which describe in detail construction and use of all essential radio test units—multi-meters, oscillators, stage-analysis testers, oscilloscope equipment, V-T voltmeters, etc. Even advanced technicians will be interested in the circuit arrangements showing the new and improved variations of well-known, basic test equipment. A MUST for every serviceman. This book contains 86 illustrations.

Outline of Contents: A Low-Cost Signal Chaser—Signal Tracer Test Unit—Simplified Practical Signal Tracer—A Home-Made Infinite-Resistance Tube Checker—Build This Direct-Reading V-T Voltmeter—How to Make a Modern V-T Voltmeter—Measuring High Values of A.C. Voltage and Current With a Low-Range Meter—How to Make a Meter-Range Extender—How to Build a Practical Tube Tester and Set-Analyzer Adapter—The Beginner's Simple Volt-Whistle—Build This Simplified Neon-Type Test Unit—Midget Oscilloscope—How to Make and Use a Frequency Wobbler—Double Tracing Your Oscilloscope—Home-Made Frequency Modulator.

### No. 26—MODERN BATTERY RADIO SETS

Whether you are a radio man or a beginner, the articles in this book give you basic circuit arrangements or elementary radio receivers which serve the dual role of teaching the elements of radio reception, as well as making perfectly operating 1- and 2-tube radio receivers. Picture diagrams and bread-board layouts galore. Advanced radio set builders are offered more complicated arrangements. Laboratory workers and engineers will find in many of the articles circuit and constructional features which have become commercial practice. Many entirely new ideas are given in this book. One of the most important volumes we recently issued. This book contains 76 illustrations.

Outline of Contents: Beginner's 1-Tube High-Gain All-Wave Receiver—Beginners-Build This 1-Tube Loop Receiver—A "3-in-1" Battery Portable—An Easily-Built "Fluwellington Superregenerative" 2-in-1 "Card File" Battery Set—A 2-Tube Superhet. With Pentagrid Regenerative 2nd-Detector—The 4-Tube Superhet. Vacation Portable—The "Lunchbox 5" Battery Portable—"The Seafarer" Loop-Type Boat Radio Set—4-Tube Permeability Portable—An All-Purpose Portable—A Typical Commercial 3-Way Portable (Pilot Models X-1452 and X-1453)—Switch for Varying "C" Bias on Battery Radio Sets—Making a Simple Portable Aerial—Making a Pilot-Light Fuse—Old Auto Sets for New Cars—Using a Loop Portable in Cars—Quasi-Electric Soldering Iron—Lamp Bulbs as Resistors.

### No. 27—MODERN RADIO SERVICING TECHNIQUE

Here is a book of great importance to every radio man, every radio engineer, and particularly all radio servicemen. A list of the contents which follows shows the importance of this book, literally jam-packed to overflowing with radio-meat. Whether you are a servicing beginner or whether you are an experienced serviceman—you will find many important helps in this volume. Book is eminently practical and will solve many problems for you. More important: It will show you many short-cuts, all calculated to save your time and patience. Practical everyday data on standard receivers appears throughout the book. A whole of a book compressed into a minimum of space. Contains 98 important illustrations.

### MODERN RADIO SERVICING TECHNIQUE

An Aid to Quicker, More Profitable Servicing Through the Application of Modern Methods

### ALL ABOUT FREQUENCY MODULATION

COMPILED BY THE EDITORS OF Radio-Craft

Outline of Contents: Elementary Servicing Technique—Correct Procedure for the Servicing Beginner—Elementary Procedure for Servicing Radio Sets—A.F.C. Alignment Made Easy—Dynamic Servicing—Dynamic Testing Simplifies Servicing—Modern Receiver Test Requirements—Servicing Universal A.C.-D.C. Receivers—Servicing "Orphans" and Private-Brand Sets—Emergency Servicing Without Test Meters—Servicing Coils—Servicing R.F. Coils—Servicing Oscillator Coils—General Information—RMA Transformer Color Code—What Causes Echo, Fading?—Radio Service Puzzlers.

### No. 28—ALL ABOUT FREQUENCY MODULATION

Here is a complete compilation of pertinent data on the entire subject of the new coming art of Frequency Modulation. There is no question but that Frequency Modulation is already revolutionizing radio broadcasting in this country. Were it not for the war, there would now be a tremendous boom in this new art—yet, even with war restrictions imposed upon it, Frequency Modulation is still jumping ahead by leaps and bounds. With Frequency Modulation no longer a theory—with hundreds of stations already dotting the land and with countless hundreds of others to come when peace is achieved once more—every radio man should read up and know all there is to know on this most important subject. This particular handbook is chock-full with a tremendous amount of information which you probably will not find in any similar book in print. Outline of Contents: The ABC of F.M.—Frequency vs. Amplitude Modulation—Basic Facts About F.M. Broadcasting—Construction—Build This Practical F.M. Adapter—Audio Amplification—F.M. Audio Amplifier, Part 1—F.M. Audio Amplifier, Part 2—F.M. Audio Amplifier, Part 3—F.M. Service—Part 1, Antenna Installation and Service—Part 2, Receiver Alignment and Diagnosis—Part 3, Test Equipment for F.M. Servicing, Engineering—Part 1, The How and Why of F.M.—Part 2, The How and Why of F.M.—Theory and Design Considerations of R.F. and I.F. Coils in F.M. Receivers.

### SPECIAL SEND-NO-MONEY OFFER

It is not necessary that you send money with order. If you wish to take advantage of our C.O.D. plan, simply cut out the coupon, paste it on a post card and send it to us. Books will be sent to you immediately. All four books are listed uniformly at 50c each. No discount on less than three books.

If you wish to take advantage of our special offer, ordering three books or more, we make an unusual low price to you as follows:

3 books—	\$1.25
4 books—	\$1.50

Do not fail to send coupon today!

RADCRAFT PUBLICATIONS, INC.  
25 West Broadway, New York, N. Y.

Radcrafft Publications, Inc. 25 West Broadway, New York, N. Y.	1142
Gentlemen:	
Rush to me by return mail, as per your special offer, the following books: (check books selected.)	
<input type="checkbox"/> No. 25—HOME-MADE RADIO TEST INSTRUMENTS.	
<input type="checkbox"/> No. 26—MODERN BATTERY RADIO SETS.	
<input type="checkbox"/> No. 27—MODERN RADIO SERVICING TECHNIQUE.	
<input type="checkbox"/> No. 28—ALL ABOUT FREQUENCY MODULATION.	
I will pay postman \$1.00 (if two books are ordered) plus a few cents postage and charges. \$1.25 for three books, plus a few cents postage and charges. \$1.50 for four books, plus a few cents postage and charges. WE CANNOT SEND A SINGLE SO-CO BOOK C.O.D.	
NAME .....	PLEASE PRINT CLEARLY
ADDRESS .....	
CITY .....	STATE .....
<input type="checkbox"/> Save shipping and C.O.D. charges! Check here if you send cash with order. (Cash, U.S. new postage stamps, money order, check.) Foreign countries no C.O.D. Add 20% to all prices quoted.	

# R. F. CHOKES AS INDUCTANCE COILS

By WILLIAM J. VETTE

SINCE their introduction several years ago, I have found many uses for the popular R.F. chokes of about 2.5 mh. inductance, wound in four pies on Isolantite or ceramic cores. They are indeed quite versatile, and with very slight alteration lend themselves to use as inductance coils in a variety of applications. Especially do I find them useful as I.F. transformers and coupling impedances in ultra-compact receivers, or anywhere I wish to keep size at a minimum. Also, they are ideal for use in electron coupled circuits for beat oscillators—in fact

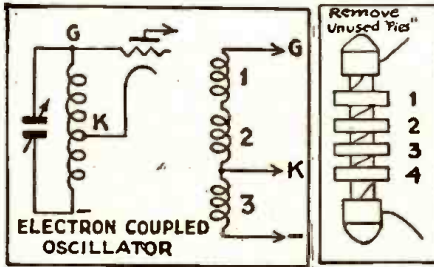

are very handy to have around when you want a neat, efficient coil of extremely small size and can't find just what you want at the supply house. Besides, these chokes, and condensers to tune them, cost a lot less than any I.F. transformer on the market.

Since the "four-pi" choke as a whole has an inductance of 2.5 millihenries, each individual section, or "pie" has an inductance of 0.625 M.H. Two pies, therefore, would have an inductance of 2 times 0.625 or 1.25 M.H.; three pies an inductance of 1.875 M.H.

An inductance of 0.625 M.H. (one pie) tunes to 850-375 kilocycles, with a condenser of 58-325 micro-microfarads.

An inductance of 1.25 M.H. (2 pies) tunes to 875-325 kilocycles with 27-180 mmf.

An inductance of 1.875 M.H. (3 pies) tunes to 1250-425 kilocycles with a 7-80 mmf. condenser. A larger condenser could

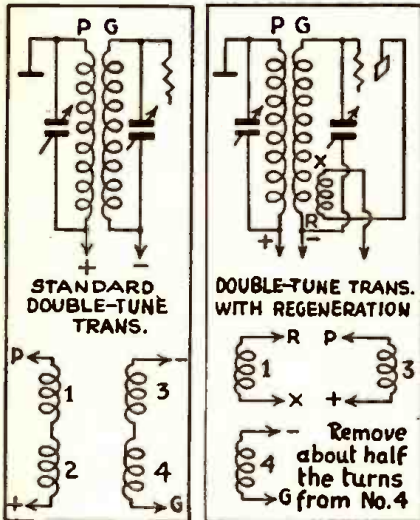

they are more useful to me as basic coil foundations than they are as R.F. chokes.

Several diagrams herewith show some of the many circuits in which I use these coils, together with the data on what alterations are necessary to adapt the chokes to these specific circuits. A table of the various frequency ranges, and the capacities necessary to tune to these specific frequencies is also given. In cases where there are two or more choices of capacity-inductance combination, it is better practice to select the combination having the higher inductance, as the use of higher inductance and lower capacity to tune to a given frequency usually results in higher efficiency.

The constructor or experimenter who decides to experiment with these flexible little coils will find, as I have, that they

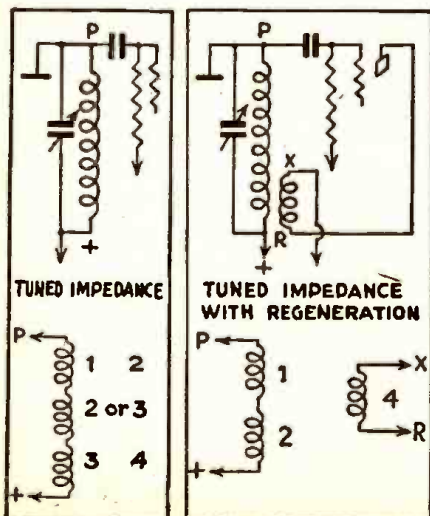

be used to extend this range.

The above values were chosen especially for working around 456 kilocycles.

## LOCATING PARTS CAUSING INTERMITTENTS

Here is a method of locating a capacitor or other part in a set that has become intermittent.

Feed the total unmodulated signal from the signal generator into the antenna of the set with the volume control on full. Since in this condition all parts of the set become microphonic, all parts of the set can be tapped in order to determine which have a loose connection or are defective.—Joseph G. Allen, Pawtucket, R. I.

—From C-D Capacitor.

## EYE LOOP FOR CLOSE INSPECTION WORK

A very handy gadget around the work bench is a jeweler's eye glass or "loop." If you wear glasses, the handiest kind is one that hooks over one lens of your glasses.

I use it to examine antenna, oscillator, R.F., I.F., and other coils and parts.

Many times with the use of this glass, I am able to dig out the open end of small wire and repair an open that otherwise could not be located. I also use it to read parts values on small blurred wiring diagrams.—H. B. Workman, Waverly, Ohio.

—From C-D Capacitor.

## Get This Electric Dry Shaver ABSOLUTELY FREE!



JUST THINK OF IT—you can get absolutely FREE, the useful DRY ELECTRIC SHAVER which is shown at the left. This ELECTRIC DRY SHAVER is sent to you by the publishers with a one-year subscription to RADIO-CRAFT.

### Here Are the Features of The ELECTRIC DRY SHAVER

Constructed of metal with attractive red bronze finish. Scientifically constructed to give a perfectly clean shave. 5-foot rubber insulated cord and plug. Constructed to last for many years.

Operates from 110-volt, 60-cycle A.C. electric line. Carries a two-year manufacturer's guarantee. A fine quality, self-sharpening toilet necessity.

Send your subscription to RADIO-CRAFT for One Year (12 Issues) and receive absolutely FREE one of these remarkable Electric Dry Shavers. New subscribers are accepted or you may extend your present subscription another twelve months. Mail your remittance of \$2.00 (plus 25c for shipping charges on Shaver) to the publishers. (Canada and foreign \$2.75.) You will receive your DRY ELECTRIC SHAVER immediately by return mail. Use coupon below to enter your subscription.

### RADIO-CRAFT

25 W. B'way., New York, N. Y.

RADIO-CRAFT, 25 W. BROADWAY, New York, N. Y.

Gentlemen: Enclosed find my remittance of \$2.00 for which enter my subscription to RADIO-CRAFT for one year (12 Issues). Send me immediately FREE ELECTRIC DRY SHAVER (Canada and foreign \$2.75). In U. S. add only 25c additional to cover shipping charges on Shaver.

New Subscriber  Extend Present Subscription

Name .....

Address .....

City ..... State .....

(Send remittance by check, money order or unused U.S. Postage Stamps. Register letter if you send cash or stamps.) RC-1142

OPERATES ON 110-VOLT, 60-CYCLE A.C. LINE

WE SHIP ELECTRIC DRY SHAVER THE SAME DAY YOUR SUBSCRIPTION ORDER IS RECEIVED.

CLIP COUPON AND MAIL

# Lowest Priced Publications for Experimenters

10 FOR 50c

Here is a large number of radio, short-wave, and mechanical "how-to-make-it" designs. Each is a special publication originated by masters in their respective fields. For the low price of 50 CENTS, you buy TEN complete pamphlets with photographic reproductions, complete mechanical layout, and full description to make it possible for anyone to build the project in question.

PLEASE ORDER EACH PROJECT BY ITS PUBLICATION NUMBER, and use the special coupon below. We accept money-orders, cash, checks or new U. S. stamps. (No foreign stamps.) If you send cash or stamps, register your letter. Money refunded if you are not satisfied. ANY TWENTY-FOUR PUBLICATIONS FOR ONE DOLLAR.

## SHORT-WAVE RECEIVER PUBLICATIONS

- HOW TO MAKE THE "OSCILODDYNE" 1 TUBE WONDER SET. No. 101
- HOW TO MAKE THE "19" TWIN-PLEX (ONE TUBE PERFORMS AS TWO) RECEIVER. No. 102
- HOW TO MAKE THE WIZARD-1 TUBE 50-WATT TRANSMITTER. No. 103
- HOW TO MAKE THE IMPROVED 3-TUBE DOEPLER SET FOR BATTERY OPERATION. No. 104
- HOW TO MAKE THE "GO-GET-EM" 2" RECEIVER FOR THE BEGINNER. No. 105
- HOW TO MAKE THE 1-TUBE-ALL-ELECTRIC OSCILLODDYNE. No. 106
- HOW TO MAKE THE 2 TO 5 METER TWO-TUBE LOUDSPEAKER SET. No. 107
- HOW TO MAKE THE 3-TUBE BATTERY SHORT-WAVE RECEIVER. No. 108
- THE BRIEF-CASE SHORT-WAVE RECEIVER AND HOW TO BUILD IT. No. 109
- HOW TO BUILD THE POCKET SHORT-WAVE RECEIVER. No. 110
- HOW TO BUILD THE CIGARETTE BOX 1-TUBE "CATCH ALL" RECEIVER. No. 111
- HOW TO BUILD THE "DUAL-WAVE" SHORT-WAVE BATTERY RECEIVER. No. 112
- HOW TO BUILD THE 1-TUBE "53" TWIN-PLEX" RECEIVER. No. 113
- HOW TO BUILD THE PORTABLE MINDYNE SHORT-WAVE BATTERY SET. No. 114
- HOW TO BUILD THE HAM-BAND "PEE-WEE" 2-TUBER. No. 115
- HOW TO BUILD THE DUO-AMPLIDYNE. No. 116
- HOW TO BUILD THE "MONO-COIL 2." No. 117

## RADIO BROADCAST RECEIVER AND SPECIAL RADIO PUBLICATIONS

- HOW TO MAKE THE A.C.-D.C. "CASH BOX" RECEIVER No. 118
- HOW TO MAKE BEGINNER'S 2-TUBE ALL-WAVE SET. No. 119
- HOW TO BUILD THE "RADIO-LAMP" 4-TUBE TABLE RECEIVER. No. 120
- HOW TO BUILD A SUPER-SENSITIVE ALL-WAVE CRYSTAL SET. No. 121
- HOW TO BUILD THE 2-TUBE "PENTODE PORTABLE" BROADCAST SET. No. 122
- HOW TO BUILD THE RADIO "TREASURE" FINDER. No. 123
- HOW TO BUILD THE GERNSBACK ONE-TUBE PENTODE LOUDSPEAKER SET. No. 124
- HOW TO BUILD THE WORLD'S SMALLEST ONE TUBE BATTERY RADIO. No. 125
- HOW TO BUILD A 6-TUBE BATTERY ALL-WAVE "FARM PORTABLE" SET. No. 126
- HOW TO MAKE AN A.C.-D.C. ONE-TUBE "DEAF AID." No. 127
- HOW TO BUILD A PIANOTRON. No. 128
- HOW TO BUILD THE ONE-DOLLAR RADIO. No. 129
- HOW TO MAKE A VARIABLE-TONE CODE PRACTICE SET. No. 130

## MECHANICAL PROJECTS PUBLICATIONS

- HOW TO MAKE A SOUTH SEA OUTRIGGER CANOE. No. 131
- HOW TO BUILD A PEE-WEE AUTOMOBILE. No. 132
- HOW TO BUILD A DUAL-CONTROL GLIDER. No. 133
- HOW TO BUILD A HOUSEBOAT ON PONTOONS. No. 134
- HOW TO MAKE A BAND SAW FROM OLD AUTO PARTS. No. 135
- HOW TO BUILD A REAL LATHE FOR \$5.00. No. 136
- HOW TO BUILD A SAIL CATBOAT. No. 137
- HOW TO BUILD A SIMPLE PORTABLE REFRIGERATOR. No. 138
- HOW TO BUILD A XYLOPHONE. No. 139
- HOW TO BUILD THE ROWMOBILE. No. 140
- HOW TO BUILD LARGE TESLA AND OUD'N COILS GIVING 18-INCH SPARKS. No. 141
- HOW TO MAKE AN ARC WELDER. No. 142
- HOW TO USE AN A.C. ARC WELDER. No. 143
- HOW TO MAKE YOUR OWN MICROSCOPE. No. 144
- HOW TO MAKE A WIMSHURST ELECTROSTATIC MACHINE. No. 145
- HOW TO MAKE A POWER DRILL PRESS FROM SCRAP PARTS. No. 146
- HOW TO BUILD A GOOD LATHE FOR \$1.00. No. 147
- HOW TO MAKE AND EXPERIMENT WITH AN ELECTROPHOROUS. No. 148
- HOW TO MAKE AN ELECTRIC ARC WELDER FROM AN AUTO. MOBILE GENERATOR. No. 149

## RADIO PUBLICATIONS, 25 West Broadway, NEW YORK, N. Y. RC 1142

I enclose \$..... for the publications listed by number, at right, at the rate of 50c FOR ANY TEN PUBLICATIONS. NO ORDER FOR LESS THAN 50c ACCEPTED. \$1.00 for 24 publications. These publications are to be sent to me postpaid. I have placed a circle around each number which I want. PLEASE PRINT CLEARLY

Name .....	Address .....	101	102	103	104	105	106
City .....	State .....	107	108	109	110	111	112
		113	114	115	116	117	118
		119	120	121	122	123	124
		125	126	127	128	129	130
		131	132	133	134	135	136
		137	138	139	140	141	142
		143	144	145	146	147	148
							149

## 10 BEST RADIO BOOKS 10 CENTS EACH

RADIO FANS EVERYWHERE—these fine ten cent text books give you an excellent foundation for the study of RADIO. They are clearly written, profusely illustrated and contain over 15,000 words in each book. You'll be

amazed at the wealth of information contained in these handy books. Excellent for reference—ideal for every technical library. YOUR MONEY BACK if you are not satisfied. PROMPT SHIPMENTS

- No. 1—HOW TO BUILD FOUR DOERLE SHORT WAVE SETS
- No. 2—HOW TO MAKE THE MOST POPULAR ALL-WAVE 1- AND 2-TUBE RECEIVERS
- No. 3—ALTERNATING CURRENT FOR BEGINNERS
- No. 4—ALL ABOUT AERIALS
- No. 5—BEGINNERS' RADIO DICTIONARY
- No. 6—HOW TO HAVE FUN WITH RADIO
- No. 7—HOW TO READ RADIO DIAGRAMS
- No. 8—RADIO FOR BEGINNERS
- No. 9—SIMPLE ELECTRICAL EXPERIMENTS
- No. 10—TELEVISION

### BOOKS ARE ALL UNIFORM

Every book in the GERNSBACK EDUCATIONAL LIBRARY has 32 pages—with illustrations varying from 30 to 60 in number. Each little volume contains over 15,000 words. Positively radio's greatest book buy! If you do not think these books worth the price asked, return them in 24 hours and your money will be instantly refunded.

## RADIO PUBLICATIONS • 25 WEST BROADWAY • NEW YORK, N. Y.

RADIO PUBLICATIONS, Dept. RC-11-42, 25 WEST BROADWAY, NEW YORK, N. Y.

Gentlemen: Please send immediately, POSTPAID, the book numbers circled below. I am enclosing ..... cents —each book being 10c.

Send FREE listing of 48 new 10c publications. PLEASE PRINT CLEARLY

Name ..... Address .....

City ..... State .....

Remit by check or money order—register letter if you send cash or unused U. S. postage stamps.

MAIL COUPON TODAY!

## A Simple Junk Part Amplifier

HERE is a simple yet effective audio frequency amplifier. This set is used to increase the power and volume of any one, two or three tube headphone set. It may enable the use of a sneaker on the more powerful stations. On my two-tube headphone set I use an eight inch dynamic speaker with the amplifier. This entire set can be made from old radio parts. For a chassis use either a board or metal base. If you use a metal base be sure that it is well insulated. The primary or the input of the transformer goes to the two phone jacks of the detector set. The jacks are then moved to the output of the amplifier. For the transformer I used a Thordarson type 3-1. The

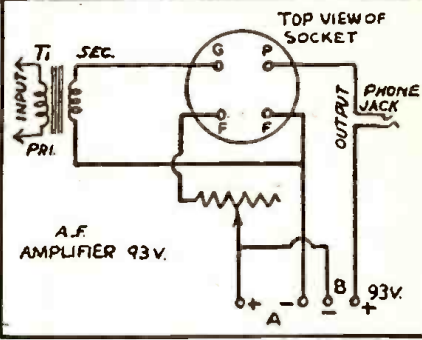

volume control (T3) is not necessary if one is not available. Switches can be installed between the B+ and phone jack, A+ and the tube for convenience. For the "B" battery power use either a 45- or 90-volt battery. For the "A" power use one or two No. six 1.5-volt dry cells. Quality flashlight batteries will also work. Two or three of these amplifiers can be connected (in series) to one detector set. A fine low-cost amplifier for the small job.

### Parts List

- 1—Type 26 tube, T2
  - 1—Four prong socket
  - 1—Audio frequency transformer, ratio 3:1 or 5:1
  - 2—45-volt batteries
  - 2—No. 6 dry cells
  - 1—Volume control (almost any value)
  - 1—Phone jack
  - 1—Baseboard or chassis (metal) hardware
- JACK W. JORANGER,  
1008 Second Ave. North,  
Great Falls, Montana.

## NEW CODE PRACTICE OSCILLATOR

Editor:

This circuit utilizes a 1S4, one of the new type of bantam "button base" tubes. As these tubes require very little current to operate them, the cost of upkeep on such an oscillator is very low. The circuit is the usual code practice oscillator circuit, except for the fact that instead of using the conventional 67½ volt B battery, a battery which at the present time is quite expensive and hard to obtain, I use five ordinary "pen light" cells for the "B" and "A" supplies. Three are hooked in series to furnish 4½ volts for "B" voltage, and two are hooked in parallel for the 1½ volt "A" supply. This circuit works very well, actually operating a 2" PM speaker with a fair amount of volume, considering the size and characteristics of the tube used. Plenty of volume is secured for headphone operation, and many sets of phones may be hooked in for group instruction.

As the pictures indicate, the unit is housed in a small case, small enough to be mounted

directly on the same base on which the key is mounted. The strap is removed from the audio transformer, in order to conserve space. A small bracket is made from aluminum for the mounting of the tube socket. A SPST switch is used to cut off the battery power, and small phone jacks are mounted

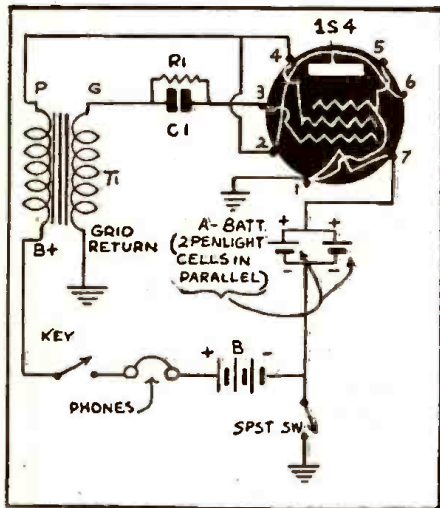

on the top of the case for the earphones. The grid leak may be changed in value for tone to suit the individual builder. In the case of different tubes it may be a little harder to bring the tube into oscillation, but by adjusting the grid leak to a proper value the tube will oscillate. Above all do not become discouraged, the rig will work very well, as I have found by experience in building two or three of them for various fellows. This is just the thing for the trainee, that only has a limited space for code practice, and who does a good deal of traveling.

**PARTS LIST**

- One resistor, 10,000 ohms, R1
- One condenser, .00025 mf. mica, C1
- One Thordarson midget audio-transformer 3:1 ratio, T1
- Five penlight cells
- One key
- One set headphones
- One socket for 1S4 tube
- One 1S4 tube

FRANK J. CAMPBELL,  
Oakland, Calif.

**IMPROVISING A DIAL DRIVE**

A Silver-Marshall, Model 30, in service for more than a decade, required a tuning drive—after the tuning knob shaft became useless, because the supporting die-casting had disintegrated. After the collapse of this die-cast yoke, there was no further use for the conventional bronze cable, the tuning knob, its shaft, nor the two cable-takeups.

In this metropolis, all possible sources of duplicate parts were searched. Even the manufacturer is out of business. Therefore, a new means had to be devised for operating the drum carrying the station numbers. The bronze cable could not be used because of its springiness. Hard twist sea island cord was used instead. Cord size was chosen to properly fill the cable grooves on the drum. The owner opposed drilling, or any change on the face plate carrying the factory arrangement of three knobs.

The perspective drawing shows how the problem was solved: As the cords leave the bottom of the drum, they pass through the agatine guide. This agatine piece is mounted with its own german silver fastening. Every good fishing rod has similar guides for the fish line. Agatine was chosen for

this job because it is almost non-frictioning; consequently non-chafing on the cords of the dial drive. The metal mounting on an agatine guide (as used on fishing poles) can be soldered to the back of the front dial plate. Over the back of the hole for the tuning knob shaft the 3/8" center part of an overcoat button was fastened—with collodion cement. Over the front of the same hole, a similar part of another overcoat button was cemented. Overcoat buttons were used because the thread holes were adequate for the cords. Their finish with a high polish made smoothness through which to operate the cords.

When the proper working length was determined for the cords, the surplus was cut off. To each outer end was fastened a

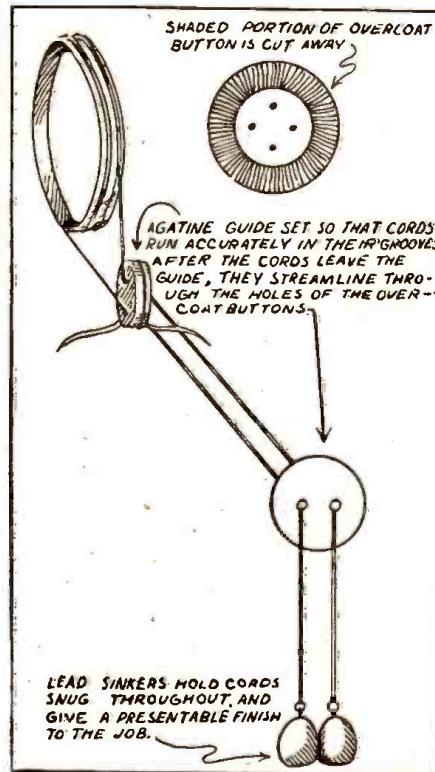

fisherman's 3/8" round lead sinker, for convenient manipulation. These weights serve also to keep the cords taut, in the pulley grooves, and help give a nice finish to the improvised dial drive.

J. C. GREEN,  
Los Angeles, Calif.

**THE ARMY SIGNAL CORPS  
Wants  
RADIO CODE OPERATORS**

**THIS IS YOUR CHANCE!**

You can qualify easily and quickly, without leaving your own home . . . let the Candler System show you how to read code at high speeds—just like you read print. Thousands of skilled operators have learned the Candler Way of sending and receiving Code rapidly. Remember the Army, Navy and our Merchant Marine have a place waiting for trained Code operators. Let the Candler System, with over a quarter of a century of experience show you how you too can learn with their easy, practical system. Courses available for beginners and operators wishing maximum code proficiency. Why delay! . . . it costs you nothing to get the facts! . . . and no salesman will call.

**FREE Book of Facts!**

Send for it today—your copy is waiting for you! Tells you all about the Code Champions who are Candler graduates . . . gives you many inside tips FREE! Mail a post card for your copy now!



**CANDLER SYSTEM CO.**

Box 928 • Dept. S-11 • Denver, Colorado

**RADIO CATALOG NO. 50**  
164 PAGES SETS-PARTS SUPPLIES FLUORESCENT  
Burstein Applebee Co.

**BIG FREE CATALOG**  
EVERYTHING IN RADIO  
Sets, parts, supplies, public address systems, amateur equipment, testers, kits and fluorescent lighting at lowest prices. Huge stocks, bought months ago . . . ready for shipment the same day your order is received. The Defense Program is making big demands on our industry but because of our advance buying we are able to fill your orders promptly and efficiently.

**PACKED WITH VALUES!**

**BURSTEIN-APPLEBEE COMPANY**  
1012-14 MCGEE STREET, KANSAS CITY, MISSOURI

**Inventions Wanted  
Patented or Unpatented**

We have been successfully selling inventions, patented and unpatented, since 1924. Write us, if you have a practical, useful idea for sale.

**CHARTERED INSTITUTE OF AMERICAN INVENTORS**

Dept. 109 Barrister Building, Washington, D.C.

**LAST CHANCE**

that you will have to buy

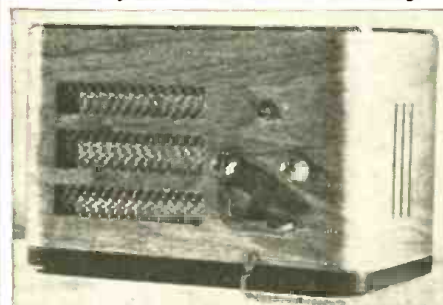

**Crosley CHATTABOX**  
INTERCOMMUNICATION SYSTEM OF TWO UNITS FOR **\$24.75**  
LIST PRICE—\$59.50 A PAIR

Complete two-way wireless loud speaking system. Perfect performance. Plug into any 110 volt house socket A.C. or D.C. Equipped with Call-Listen-Talk switch and volume control.

No installation charges. Modulated carrier signal travels over the electric light lines. IDEAL FOR OFFICES, STORES, FACTORIES, SCHOOLS, LIBRARIES, HOMES AND WHEREVER INTERCOMMUNICATION IS DESIRED. EXCELLENT SPEECH CHARACTERISTICS.

Each unit is housed in beautiful 2 tone veneered cabinet with grilled speaker front.

Name .....

Address .....

City .....

**KORROL MFG. CO.**

350 GREENWICH ST. (DEPT. RC11)  
NEW YORK CITY

## DISPOSAL SALE AMPLIFIERS & SPEAKERS

THIS sale comprises amplifiers used in the construction of Juke-Boxes; made by well known manufacturers such as: Rauland and Operadio. All equipment is reconditioned (factory finish) and in perfect mechanical and electrical condition.

THERE ARE ONLY A FEW HUNDRED OF THESE AMPLIFIERS LEFT. WHEN THEY ARE GONE, NO MORE CAN BE HAD AT ANY PRICE, FOR THE DURATION! SEND YOUR ORDERS NOW! COMPLETE SATISFACTION OR MONEY REFUND.

Photo shows 30 watt ampl. # 104A

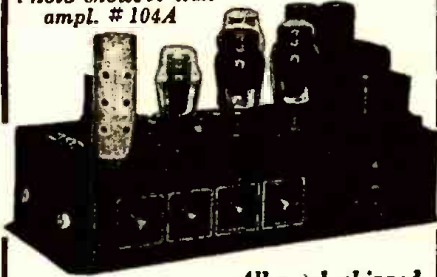

All ampl. shipped Ready to operate

#102A—12 WATT PUSH-PULL 2A3 AMPLIFIER  
Frequency response plus or minus 2DB. from 30 to 15,000 CPS. bass and treble boost. Inputs for phono pick-up or radio tuner. Output impedance 8 or 16 ohms to P.M. or Electro-Dynamic speakers, supplies field current for one or two 2500 ohm speaker fields. An excellent amplifier for FM or re-cording. **\$18.45**

Shipping weight 25 lbs.

#103A—20 WATT PUSH-PULL 6L6 AMPLIFIER  
Input for one crystal or dynamic microphone. Input for one crystal or magnetic phono pick-up. Full range tone control. Frequency response 30 to 10,000 CPS. Output impedance 8 or 16 ohms to P.M. or Electro-Dynamic speakers, supplies field current for one or two 2500 ohm speaker fields. **\$15.95**

Shipping weight 24 lbs.

#104A—30 WATT PUSH-PULL 6L6 AMPLIFIER  
Input for two crystal, dynamic or velocity microphones individually controlled. Input for crystal or high impedance phono pick-up. Full range tone control. Frequency response 30 to 10,000 CPS. Output impedance 2, 4, 5, 8 and 16 ohms to P.M. or Electro-Dynamic speakers, supplies field current for one or two 2500 ohm speaker fields. **\$21.45**

Shipping Weight 26 lbs.

All Amplifiers Less Tubes & Speakers

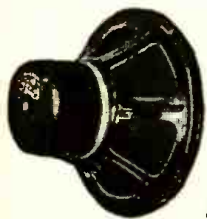

JENSEN 10 INCH  
ELECTRO-DYNAMIC  
SPEAKER

2500 OHM  
FIELD  
16 OHM  
VOICE-COIL

EACH **\$2.95**  
Shipping Weight 7 lbs.

ORDERS SHIPPED SAME DAY AS RECEIVED. All Goods are sent Express collect if no money for Parcel Post is included in remittance. Customers in Foreign countries are requested to remit in U. S. Currency or International Money Orders and include enough money to ship goods prepaid. Order from this ad. 5% deposit required on all C.O.D. orders.

**PEERLESS RADIO  
AND SOUND CORP.**

11 So. Desplaines St., Dept. 1142 CHICAGO, ILL.

## Diagrams for

# The Radio Experimenter

This is a new department. If you have a new Hook-Up, send it along; a pencil diagram will do. Be sure to include a brief description.

All diagrams and descriptions accepted and published will be awarded a year's subscription. Diagrams may be for receivers, adapters, amplifiers, etc. Send them to Hook-Up Editor, RADIO-CRAFT, 25 W. Broadway, New York City.

### ECONOMY 15-WATT AC-DC PHONO AMPLIFIER

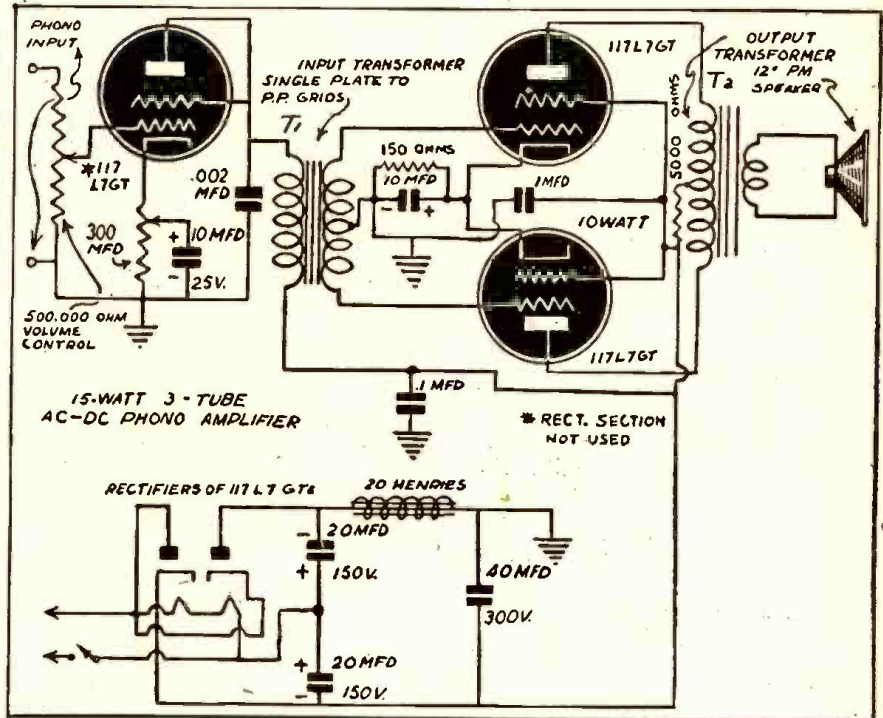

THIS phono-amplifier is designed primarily for economy without sacrificing quality. The parts for this amplifier may be purchased for \$7.00, less tubes. On most high-quality amplifiers the tone control is seldom touched after one setting so none was incorporated here. Instead, a small fixed condenser is run from plate to ground of the first amplifying tube. Different capacities may be tried for different amounts of "bassyness."

The high output of the amplifier is accounted for by the voltage doubling circuit

used, supplying 230 volts to the 117L7GT plates. The high value of the filter condensers is needed for proper operation of this circuit, so do not substitute smaller values.

The first amplifier is a 117L7GT connected as a triode. Push-pull 117L7GT's are used in the output. As this is an AC-DC set, it should be included in a cabinet, taking no chance that the chassis become grounded.

FRANKLIN WILLIAMS,  
Glendale, Calif.

## EXPERIMENTS WITH ELECTRICITY

EVER since I was ten years old I have been interested in electricity and electronics and in that time I have performed many experiments. Many of them I have found in *Radio-Craft* (dating from 1930 to the present) and many of them are "original." It is my hope that the latter, too, may be of interest to those who get a kick out of experimenting as I do.

A good paper filter condenser, as you know, will hold a charge for a long time. If it is discharged through a high resistance the discharge time is much longer than if it is discharged through a low resistance. When the values of the condenser and the leakage resistor are rather high, the time required to fully discharge the condenser can be lengthened to about a minute. This leakage current is not high enough for any power consuming devices but it can be used to light small neon tubes of the 1/10 watt

variety by inserting it in series with the leaking resistance as shown in the diagram.

When the S.P.S.T. switch is closed, the condenser gets the full 300 volts and the neon tube lights to about half its rated brilliance. In the open position the condenser discharges through the resistor and the neon tube.

The comb, I have discovered, holds great possibilities as a source of portable energy. When rubbed through the hair and touched to a neon tube, photo-emissive cell, gas rectifier, light bulb, or dead fluorescent tube a flash of light will result. If you walk across a rug and touch one of the above electronic devices (with one side grounded) the resulting flash is of brilliance parallel to that of the comb.

This energy can also be used for control purposes by making use of what I call a



"Static Amplifier," which closely resembles the floating grid relay in an early edition of *Radio-Craft*. I thought for quite a while that I had something until I read the article, but at least I have an original use for it. The diagram illustrates quite clearly the hook-up. The screen grid and the plate are tied together and form the anode, which is given a positive potential of about 45 volts. This voltage causes a plate current of between 1 and 3 ma.—most suitable for relay purposes. The relay is the conventional 2500-ohm type which is used on most photo-cell amplifiers. It should be adjusted to a point where the contacts just meet. Any charged body nearing the tube drops the plate current and the relay opens. It must

be understood that the back-stop contact is used to close the auxiliary circuit when the control voltage is being applied.

The sensitivity depends largely upon the tube being used. I use a 24A in mine though I have tried 35s, 55s and 58s with about the same results. When functioning properly the relay should open when a charged comb comes within a foot of the tube. The maximum distance depends mainly upon the sensitivity of the tube, the strength of the charge and the humidity of the air. In a dry room distances up to three or four feet can be reached. A spark coil will radiate a strong enough signal to operate the relay from distances up to ten feet.

This "floating grid" amplification, which

is relatively high, can also be put to uses other than static relays, as, for instance, in my "directly" direct coupled photo-cell amplifier. It is essentially the same as the static relay. The photo-cell is connected between the grid and the exciting voltage and no grid return is provided.

I hope that these experiments will offer some other beginner, or ham, as much fun as they have brought me. For the fellow who just does wiring from a book, I believe that experiments such as these will really give him a wider scope of the fun which can be had with a real worthwhile hobby.

VERNON FOWLER,  
Milwaukee, Wis.

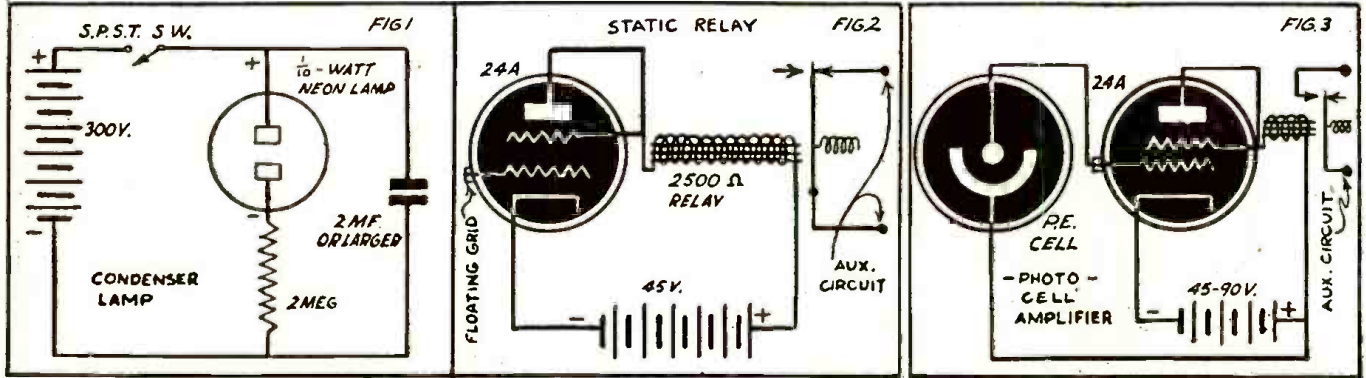

### FOUR TUBE RECEIVER

SHOWN here is a diagram of a four-tube receiver which has brought in every continent. In building this receiver careful wiring is necessary. Be sure that all leads are as short as possible. Any good set of coils may be used. I used two sets of Bud Coils No. Ck-356 with excellent results. (The R.F. coil and the detector coil are the same.) The R.F. coil is shielded to eliminate any possibility of inter-coupling between the two tuned circuits. Although it is best to use headphones, this receiver will produce sufficient volume on most stations for speaker use.

The power supply is built on a separate chassis in order to prevent any hum or noise which might emanate from that source.

The receiver is built on a 7x9x2 inch electroalloy chassis and a 6x10 inch panel. In soldering the connections to the condensers be sure that the heat of the iron does not damage the condensers. This is especially true of the 0.05 mf. blocking condenser between the plate of the 6F6 tube and the crystal headphones circuit. Almost any D.C. leakage through this condenser will damage the crystal headphones hopelessly beyond repair.

After the set has been wired and checked, turn on the power supply and listen—if no hiss or click is heard even when the regeneration control is fully advanced this would indicate the tickler is connected in reverse. If after the leads have been

changed there is a loud whistle or a squeal this would indicate too many tickler turns. Most manufactured coils have too many turns on the tickler for cathode-regenerative detector circuits, especially those covering the lower frequency ranges. It is necessary to remove one or two turns at a time until it slides into oscillation when the regeneration control is advanced to about 3/4 the way full-on. The adjustment of the 35 mmf. R.F. trimmer is not at all critical and a single setting for each range is usually all that is required.

This receiver is excellent for copying C.W. For listening to phone stations the regeneration control should be set at a

(Continued on page 120)

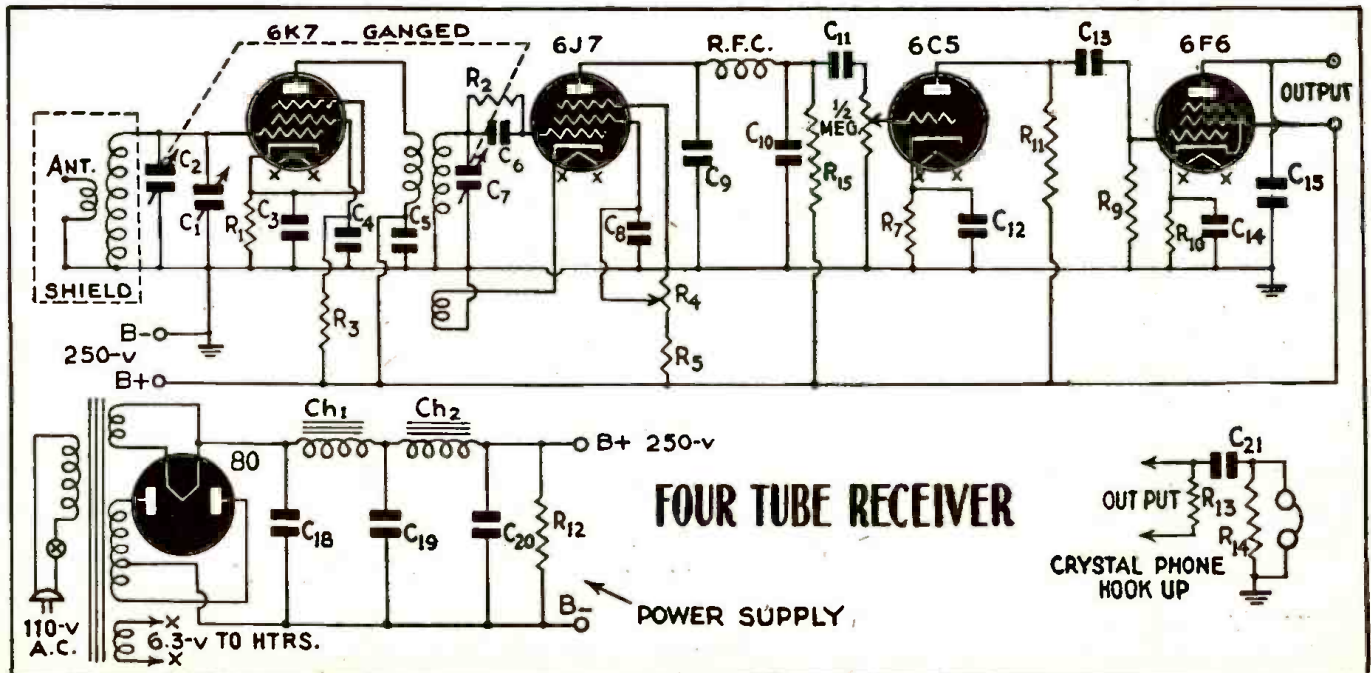

# WHILE THEY LAST

All of the attractive items listed here are brand new. ALL are in PERFECT WORKING ORDER. In many cases, the parts alone total more than the price we are asking. 100% satisfaction guaranteed or your money refunded. ORDER FROM THIS PAGE. Use the convenient coupon below. Include sufficient extra remittance for parcel post charges, else order shipped express, collect. Any excess will be refunded. C.O.D. shipments require 20% deposit. If full remittance accompanies order, deduct 2% discount. Send money order, certified check, new U. S. stamps. No C.O.D. to foreign countries.

**ORDER TODAY LIMITED QUANTITIES PROMPT SHIPMENTS ASSURED**

### HANDY WORKSHOP OUTFIT

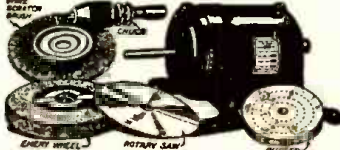

Here is a marvelous article that to the best of our knowledge has never sold at such a low price. This outfit must be seen to be appreciated. It delivers the goods! It comprises a variable speed universal motor for 110 volts A.C. or D.C. Made originally for dictaphone machines by American Gramophone Co. Motor is reconditioned and in excellent condition; all other parts are brand new. Special lever control permits various speeds up to 3000 r.p.m. Measures 7 1/2" x 3 3/4" diam. overall.

Included in the outfit are the following items, as illustrated: 1 excellent chuck which takes drills and other tooling; chuck is easily screwed to motor shaft; standard emery wheel, 1/2" diameter; fine steel rotary saw, 4" diameter; wire scratch brush, 4" diameter; standard cloth buffer, 3" diameter. Total Wt. 9 lbs.

ITEM NO. 149 Complete outfit, including motor. YOUR PRICE ..... **\$5.45**

### VARIABLE SPEED UNIVERSAL MOTOR

FOR 110 VOLTS, A.C. OR D.C.

Made for Dictaphone machines by American Gramophone Co. Used, but in excellent condition. Special lever control permits variable speeds up to 3000 r.p.m. 1/2" shaft extends from both sides of motor. Measures 7 1/2" x 3 3/4" diam. overall. Shp. Wt. 6 3/4 lbs.

ITEM NO. 11 YOUR PRICE ..... **\$2.45**

### WESTON MODEL 562 A.C.-D.C. AMMETER

Designed by Weston for the Eastman Kodak Co. It is a Precision-built meter—no type which, with suitable shunts, can be used as a milliammeter too. It is 2" in diameter and designed for panel mounting. Bakelite base and black-enamelled cover. Shp. Wt. 2 lbs.

ITEM NO. 35 YOUR PRICE ..... **\$1.25**

### POWERFUL ALL-PURPOSE INDUCTION MOTOR

IDEAL FOR EXPERIMENTERS—101 USES

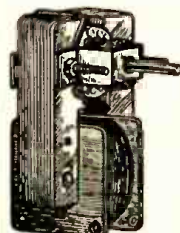

Sturdily constructed to precision standards. This self-starting shaded pole A.C. induction motor is powerful enough for a large variety of uses. Some of these are: Automatic Timing Devices, Current Interrupters, Electric Fans, Electric Chimes, Window Displays, Photostat Control Devices, Electric Vibrators, Small Grinders, Buffers and Polishers, Miniature Pumps, Mechanical Models, Sirens, and other applications.

Consumes about 15 watts of power and has a speed of 3,000 r.p.m. When geared down, this sturdy unit will constantly operate an 18-inch turntable loaded with 200 lbs. dead weight—THAT'S POWER! Dimensions, 3" high by 2" wide by 1 3/4" deep; has 4 convenient mounting studs; shaft is 3/16" long by 3/16" diameter, and runs in self-aligning oil-retaining bearings. Designed for 110-20 volts, 50-60 cycles, A.C. only.

ITEM NO. 147 YOUR PRICE ..... **\$1.45**

### 100 POWER TELESCOPE LENS KIT

Make your own high powered 8 ft. telescope! Now you can thrill to a close-up view of the worlds out in space. See the rings around Saturn, the mountains of the moon! Kit contains 3" diam. 75" focal length. Ground and polished objective lens and 2 astronomical eye-pieces, magnification 50x and 100x. Complete kit with full instructions.

ITEM NO. 123 YOUR PRICE ..... **\$1.95**

### WESTERN ELECTRIC BREAST MIKE

This is a fine light-weight aircraft carbon microphone. It weighs only 1 lb.

Mike comes with breast-plate mounting and has 2-way swiveling adjustment so that it can be adjusted to any desired position. There are 2 woven straps—one goes around neck, the other around chest. Straps can be snapped on and off quickly by an ingenious arrangement.

This excellent mike can be adapted for home broadcasting or private communication systems. By dismounting breastplate, it can be used as desk mike. Comes complete with 6-foot cord and hard rubber plug. Finished in sherardized plate, non-rustable.

THIS IS A BRAND NEW MIKE. IT HAS NEVER BEEN SOLD AT SUCH A LOW PRICE BEFORE. ORIGINAL LIST PRICE \$15.00. Shipping weight, 2 lbs.

ITEM NO. 152 YOUR PRICE ..... **\$1.00**

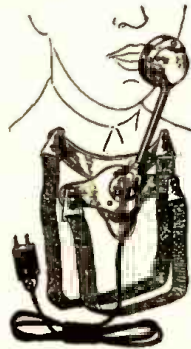

### METAL CUTTING SAW

Here is an ideal metal-cutting saw made of fine tool steel specially designed to cut metal. Teeth are set at a special double angle for metal-cutting work. Saw is specially hardened for long and extended use; measures 3 3/4" diameter; center hole is 3/8" square; thickness 42/1000 (42 mils.) 3/64".

ITEM NO. 151 YOUR PRICE ..... **50c**

### POWER ADJUSTABLE RHEOSTAT

Here is an excellent rheostat used especially to regulate the speed of small motors, such as our Handy Workshop Outfit. This rheostat can be used in connection with motors up to 1/20 h.p.

This fine rheostat is wire-wound on porcelain insulation. The black enamel steel casing is perforated for ventilation. Adjustable handle regulates speed of motor easily and smoothly. Size 2"x2 3/4" overall. Shp. Wt. 2 lbs.

ITEM NO. 153 YOUR PRICE ..... **\$1.20**

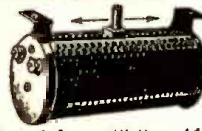

### AMAZING BLACK LIGHT!!

Powerful 250-Watt Ultra-Violet Source



The best and most practical source of ultra-violet light for general experimental and entertainment use. Makes all fluorescent substances brilliantly luminous. No transformers of any kind needed. Fits any standard lamp socket. Made with special filter glass permitting only ultra-violet rays to come through. Brings out beautiful phosphorescent hues in various types of materials. Swell for amateur parties, plays, etc. to obtain unique lighting effects. Bulb only. Shp. Wt. 1 lb.

ITEM NO. 87 YOUR PRICE ..... **\$2.00**

### WATT-HOUR METER

Completely overhauled and ready for immediate service. Designed for regular 110-volt, 60 cycle 2-wire A.C. circuit. Servicemen use it in their shops to check current consumption of sets, soldering irons, etc. Keen costs down. If dismantled the parts alone would bring the price. The elaborate gear train could be used as a counter on machines of various kinds. Simple to install: 2 wires from the line and 2 wires to the load. Sturdily constructed in heavy metal case. Size: 8 1/4" high, 6 1/2" wide, 2 1/2" deep. Westinghouse or General Electric. Shp. Wt. 14 lbs.

ITEM NO. 33 YOUR PRICE ..... **\$4.95**



## HAM HASH

By JIM SELLE

Hallcrafters of Chicago, in their new house organ "YOU NAME IT" has the following suggestions for the amateurs:

THE place that Hams play in the War Effort, in connection with service in the armed forces, is well known to all of us, but many opportunities to be of service are passed up by most of us because they are so obvious, or so simple that we do not realize their full importance. We shall attempt to enumerate in as few words as possible a few of the things that can be done by all of us to aid our country. First, make a list of the commercially built equipment around your shack, including transmitters, receivers, test equipment, meters, crystals, etc. All this equipment is urgently needed now to equip the large number of schools being set up by the Army, Navy, and Air Corps. Due to the large demands being made on the manufacturers for equipment to be used in actual combat service it is impossible to obtain this equipment from the usual commercial sources. After the war it will be possible to obtain modern, up to date equipment, probably at a small fraction of the present cost. Now is your chance to unload your present equipment which will in all probability be obsolete at the conclusion of hostilities due to new developments.

We shall be glad to place you in touch with the authorities who are interested in purchasing this equipment if you will contact Royal Higgins, W9AIO, or Cletus Wiot, W9TDF.

### FOUR TUBE RECEIVER

(Continued from page 119)

"dead-beat" position—that is, no "whistle" coming in with the signal.

Careful building and wiring will bring results far above your expectations.

CHARLEY WHITE, Fort Worth, Texas.

### Parts List

- CONDENSERS**
- C1—35 mmf., variable
  - C2—140 mmf., variable
  - C3—1 mf., paper, 50 V.
  - C4—1 mf., paper, 200 V.
  - C5—1 mf., paper, 200 V.
  - C6—.0001 mica
  - C7—140 mmf., variable
  - C8—.1 mf., paper, 250 V.
  - C9—.001 mf., mica
  - C10—.0005 mf., mica
  - C11—.01 mf., mica
  - C12—10 mf., 50 V.
  - C13—.01 mf., mica
  - C14—25 mf., 100 V.
  - C15—.006 mf., mica
  - C16—.01 mf., 600 V.
  - C17—.01 mf., 600 V.
  - C18—8 mf., 600 V., electrolytic
  - C19—8 mf., 600 V., electrolytic
  - C20—8 mf., 600 V., electrolytic
  - C21—.05 mf., mica

### RESISTORS

- R1—300 ohms, 1 W.
- R2—2 meg., 1/2 W.
- R3—100,000 ohms, 1 W.
- R4—50,000 ohms, pot.
- R5—250,000 ohms, 2 W.
- R6—500,000 ohms, 1/2 W.
- R7—2,000 ohms, 5 W.
- R8—250,000 ohms, 2 W.
- R9—500,000 ohms, 2 W.
- R10—500 ohms, 10 W.
- R11—50,000 ohms, 2 W.
- R12—15,000 ohms, 10 W.
- R13—50,000 ohms, 2 W.
- R14—1 megohm, 1 W.
- R15—100,000 ohms, 2 W.

### MISCELLANEOUS

- CH1—30 henry choke
- CH2—30 henry choke

### HUDSON SPECIALTIES CO., 40 West Broadway, N. Y. C.

IT'S EASY TO ORDER—CLIP COUPON—MAIL NOW ORDER FROM THIS PAGE.

HUDSON SPECIALTIES CO., 40 West Broadway, Dept. RC-1142, New York, N. Y.

I have checked below the numbers of the items I'm ordering. My full remittance of \$..... (include shipping charges) is enclosed.

OR my deposit of \$..... is enclosed (20% required), ship order C.O.D. for balance. No C.O.D. order for less than \$2.00. (New U. S. stamps, check or money order accepted.)

Circle Item No. wanted: 11/ 33, 35, 87, 123, 147, 149, 151, 152, 153

Name ..... Address .....

City ..... State .....

Send remittance by check, stamps or money order; register letter if you send cash or stamps.

**PULSE GENERATORS AND THEIR FUTURE**

(Continued from page 101)

seconds or microseconds deflection. The steepness of the pulse, (its rise from minimum to maximum), can also be determined. The necessary conversion factors of frequency versus distance and time are not given, but for those who desire to do some figuring the base figure used for computation is,  $F$  equals 300,000 meters per second (speed of light) which is considered close enough for average work. A duration of 3 to 50 microseconds, with a 1 to 5 microsecond amplitude rise, can be easily attained.

We can calculate this duration of the pulse and determine its exact time constant. Thus receivers can be designed that will respond only to signals sent out by a pulse generator.

Sometimes when establishing either a positive or a negative pulse it is found that a small amount of the opposite pulse is still present, which is not wanted, (as in cases where only one tube is being used and the signal input is high) then additional tube or tubes must be used properly biased until the proper pulse is reached. The use of additional tubes is often necessary, where due to the use of the higher frequencies the action of the piper is not sufficient and the signal has to be amplified, clipped and pipped again, until the desired result is obtained.

The use of additional tubes holds true also for the clipper tube in case a single tube cannot perform the squaring function properly. Where a sine wave is used for obtaining square waves the use of several tubes is generally necessary—the number of stages being determined by the frequency used. Generally more stages are required for high frequency work than for low frequency work. Or to put it differently—from 15,000 cycles and up, more clipper and piper stages are required, if the final wave form is to have a square top, than from 15,000 cycles down to 5 cycles.

To refer to some of the uses of pulse generators, one use would be to have receivers that would respond only to the pulses sent out by a particular pulse generator. That is, the amplitude and the duration of the pulse, would furnish the control action that is required. In communications this would assure a clearer and more constant source of signals. In measurement work the use of audio frequency square waves will show the characteristics of amplifiers and audio or transmission lines in a better way, since for a square wave with its high harmonic content to be reproduced in an oscilloscope, the intermediate apparatus (in this case, the A.F. amplifier or transmission line under test) must have a flat response, or the wave form will be distorted, which in turn indicates deficiencies in either L, C or R.

Another important use is for signaling and control purposes. Since the pulse selected has definite form and time limits, its use expands the utility of radio frequency transmissions. That is, by the use of narrow pulses, and the ability to control them within a few cycles. A single radio frequency carrier can be modulated with any number of these pulses, each pulse having in turn a definite function when received and selected for its use. In sine wave modulation, the duration of the entire wave occupies a large part of the carrier, but in pulse modulation the time limit of the pulses occupying the carrier is relatively small, thus permitting one carrier and a multi-channel signal to be used.

Where pulse modulation is to be used with frequency modulation, additional advantages manifest themselves that may have

★ ★ ★ ★ HALLICRAFTERS ★ ★ ★ ★

**CASH READY** for

**HALLICRAFTERS**

**RECEIVERS AND TRANSMITTERS!**

**Do Your Part!** If you have any modern apparatus, don't put it away in moth balls for the duration. Put it to work for **VICTORY!**

Send a detailed description of your station to **HARRISON to-day!** Give age, condition and photographs (if available). We will pay you **immediate cash!** Remember!

Development of new radio equipment is being rapidly accelerated under the pressure of military requirements.

All signs point to radically different gear when this war is over. Don't be an antique collector!

**You can buy Defense Bonds with the money!**

**HARRISON RADIO CO.**  
12 WEST BROADWAY - NEW YORK CITY

★ ★ ★ ★ HALLICRAFTERS ★ ★ ★ ★

far reaching developments in controlled signal communication. Other factors of great importance are in the offing but cannot be divulged.

It is the belief of the author that the pulse and square wave generators are here to stay and their use will be increased as the art advances.

The next article will cover complete circuit details and description of a pulse generator enabling control of the amplitude and width of the pulses generated, covering frequencies from 50 to 100,000 cycles. Also a few points on measurements using square wave generators with oscilloscopes.

A 500-pound bomb hitting 300 yards of a radio transmitter will smash all tubes by concussion, Station WJR has set up two racks of spare tubes in the basement, mounted on springs capable of floating with each concussion.

**PHOTO QSL CARDS**

For those who want some nifty photo QSLs without having to go to a lot of trouble, I suggest the following. Take an old QSL or piece of cardboard and with a razor blade cut out your call letters, leaving sufficient room on the card for the station photo. Cut out a square or rectangle large enough to accommodate your negative. The negative is held in place with mounting corners on the reverse side. Print the entire card in the usual manner. The cut-out letters will appear black. If you want your "handle" or QTH to also appear on the card, just cut 'em out on the master negative.—C. C. Erhardt

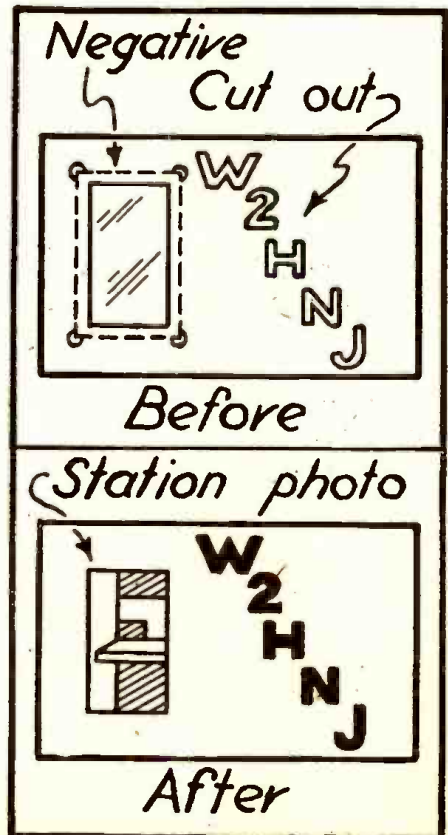

# A Colpitts-Type Code Practice Oscillator

By HENRY T. BRUMMETT

**T**HIS oscillator was designed primarily for cheapness of construction and ease of obtaining the necessary parts. The total cost is about \$5.00 unless an expensive pair of phones is used. If an inexpensive pair can not be obtained, perhaps the single-phone type still is available without a priority rating.

The circuit works perfectly and allows a great amount of choice in selecting parts from the junk-box or from an old receiver which has been discarded but still contains numerous condensers and resistors. However, in the event all new parts are to be used, cost will still be low. The resistors are of the half-watt variety. The condensers do not need to exceed 200-volt rating. The components shown in the diagram give a 500-cycle note, which is about as high as one can tolerate without the note's becoming monotonous. The pitch to be decided upon is a matter of individual taste and can easily be changed by substituting other values for the .02 tuning condensers.

The oscillator consists of a Colpitts circuit with the headphone inductances forming a part of the frequency determining circuit. The tube used is the 117L7, which eliminates any necessity for a line-voltage dropping resistor. The tube is not listed in the list of tubes to be discontinued so it is assumed that it will be available everywhere. The 100,000-ohm voltage-limiting resistor in the oscillator plate circuit allows extremely loud headphone signal strength. The volume control permits reduction of signal strength by means of varying screen voltage. The volume control may be one of the bargain type, since it need not necessarily be noise-free.

The amount of filtering shown was sufficient to provide exceptionally hum-free operation. Keying is done in the cathode circuit and gives clean sharp keying with no "tails" on the dots. As made up, the entire rig was mounted on a 2½" x 5" chassis with plenty of room to spare.

Attention is called to the 50-ohm surge protection resistor. This device is important when using a 117-volt-series tube. The filament of these tubes have a much lower resistance when they are cold than when heated. This results in a current surge on

closing the switch which greatly exceeds the rating of the tube. After the tube has reached normal operating temperature the resistance has increased to a point which allows only the rated current to flow. The function of this 50-ohm resistor is to "take up the slack." It protects the 117L7 during the surge and does not impede its operation noticeably after normal temperature is reached. I call attention to it not because it is new, but because it is frequently omitted with a resultant short life on the part of some 117L7s.

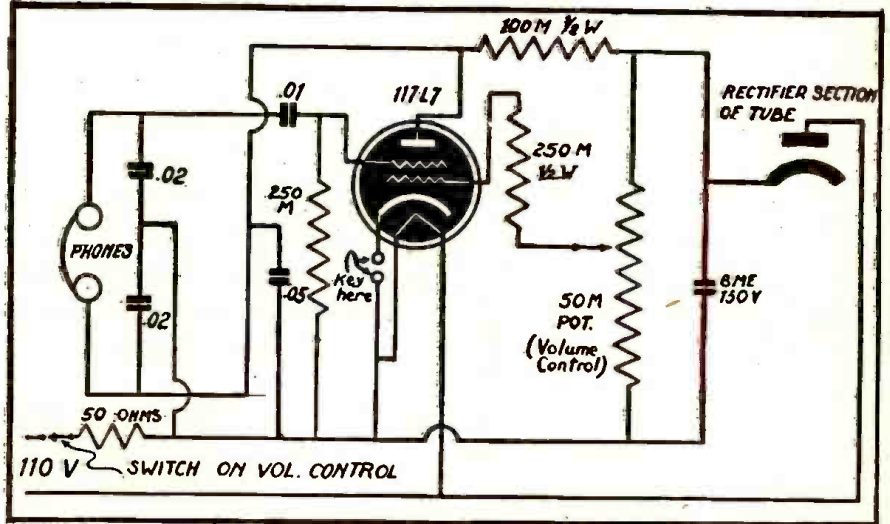

Code Practice Oscillator Circuit with Built-In Volume Control.

## RADIO AMATEUR COURSE

By G.W. Shuart "W2AMN"

RADIO & TELEVISION

PRICE 50¢

148 PAGES

6 x 9 INCHES

OVER 150 RADIO DIAGRAMS  
and TECHNICAL PHOTOGRAPHS

RADIO AND TELEVISION

25 West Broadway New York, N. Y.

### Your Money Back—

If the RADIO AMATEUR COURSE does not represent the greatest book value ever offered to the radio "fans" for ..... **50c**

To convince you that there isn't a better book buy today, the publishers of the RADIO AMATEUR COURSE make the sensational offer of a money-back guarantee on such a low-priced book. Stop in at any of the many dealers handling this book and examine it. See for yourself if the RADIO AMATEUR COURSE isn't just the book you've always wanted.

Printed on the finest coated paper—well illustrated attractive 4-color cover—complete with radio information you must have. It contains a step-by-step program for obtaining a short-wave radio education.

Written by George W. Shuart, W2AMN  
foremost short-wave authority

RADIO AND TELEVISION  
25 West Broadway, New York, N. Y.

Gentlemen: I enclose herewith my remittance of Fifty Cents (50c) for which please send me POSTPAID, my copy of the RADIO AMATEUR COURSE. (Remit by check or money order; register letter if you send cash or unused U. S. Postage stamps.) PLEASE PRINT CLEARLY

Name .....

Address .....

City ..... State ..... RC-14-42

### JUKE BOX GOES INTO BROADCAST

Last month a juke box in West Orange, New Jersey, began interspersing its records with weather reports, instructions to airplane pilots, Morse code, and static. About the same time it was reported in Brooklyn that a fire-alarm box near the Navy Yard had been turning in false alarms, even when one cop was watching it, another cop was watching the first cop, and a detective was watching them both. The official explanation given by the F.C.C. for the first phenomenon was that a burnt-out tube had converted the juke box into a short-wave receiving set, and the most popular explanation for the second was that vibrations from the subway were causing the box to send in alarms. There had been a substantial bloc in both cases that held it was the work of spies and saboteurs. We reject such explanations. Our own theory is simple. The machines were just trying to attract attention. It is in the nature of the machine, we believe, to crave notice, and it delights in causing as much outrage and annoyance as possible, all in the hope that someone will come over and take it apart. We'll never forget the electric razor we once had which left great patches of beard on our face, and our hoping people would comment on the fact that we had a new electric razor. The only way we could get an approximation of a decent shave out of it was to ask everybody in the office about it.—*The New York-er*.

(Somehow this reminds us of the chap who claimed he constantly heard radio programs. Investigation showed he was right, for tiny crystals of carborundum lodged in his ears were acting as detectors. He was a cutlery grinder [and a little crazy].—*Editor*)

# PHONO AMPLIFIER MADE WITH USED PARTS

By RICHARD HOLBROOK

THIS phono-amplifier will fulfill the requirements for a medium-powered record player using parts that can be found around almost any radio experimenter's shop.

Because of the difficulty, many times in obtaining new power transformers use was made of older type tubes making it possible to use one of the old receiver transformers.

Construction is very simple. Almost any old chassis can be used and an old receiver will yield most of the other parts. This makes it unnecessary to deplete the supply of new parts. The filter system is very good and has very little hum. As the amplifier is resistance-coupled no audio transformer

is needed. A ten- or eight-inch speaker may be used. With a .5 or 1 meg tone control the tone is very good but the base may be accentuated by inserting a small 0.01 fixed condenser across the input. A magnetic pickup may be used but the tone and volume will suffer slightly. Construction should take only about one evening to finish.

All in all this outfit should fill the bill for the beginner who wants an easily-built player or for the more advanced constructor who is looking for a job requiring few new parts. Incidentally this will work much better than trying to make use of the audio section of an old set.

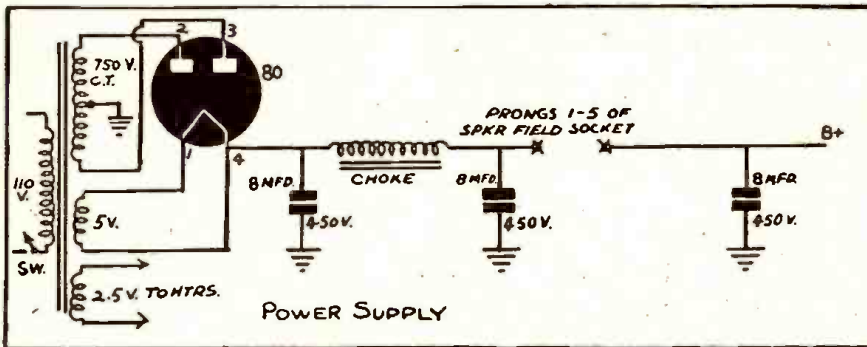
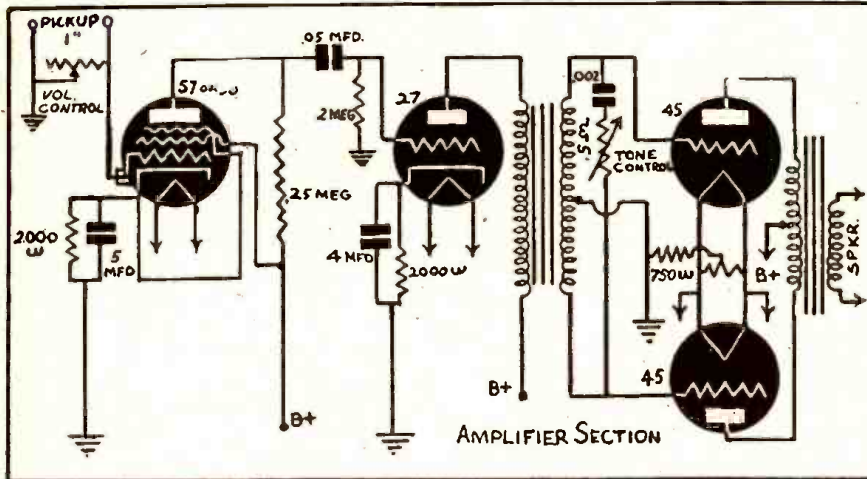

## HOW SHIP RECEIVERS GIVE AWAY THEIR POSITIONS

(Continued from page 93)

the Merchant Marine radiate to a dangerous degree, their use has also been prohibited. This is a serious situation, as consistent long distance reception, both day and night, can only be secured with a receiver using not only the long and medium waves, but also the high frequency bands.

To meet this emergency a Special Marine communications receiver covering the long and medium bands from 80 to 580 Kc. and the high frequency bands from 3 to 24 megs. has also been developed, using the same principles to reduce radiation as is used in the general purpose receiver.

This now makes available to the ships of the Merchant Marine completely safe low radiation radio receiving equipment, that not only enables the officers and men on the ships of the Merchant Marine to keep in touch at all times with the news of the world as it is happening hour by hour, but also to keep in constant touch with the

shore and ship stations transmitting information to them either by CW or phone.

## RADIO-TELEVISION INSTITUTE

Not just another radio school, but a TRAINING ORGANIZATION well equipped with LATEST and MOST EXPENSIVE APPARATUS and staffed by PRACTICAL RADIO ENGINEERS who understand the various branches of RADIO, TELEVISION and the manifold uses of ELECTRONICS.

Our students quickly find profitable positions.

Resident course only. Inquiries invited.

### Radio-Television Institute

480 Lexington Ave.  
New York City

Licensed by the State of New York

## Speed up REPAIR JOBS

With These Handy 

### SERVICE AIDS

#### New Instant Automatic Wire Stripper

Strips all types of wire instantly, easily and perfectly. Just press wire into the handles. Cuts wire too. Saves time, money and trouble for Radio Men, Electricians, Sound Men, etc. List price \$6.00.



#### Ne-O-Lite Electric Trouble Shooter



Every Radio Man and Electrician should have one. Tests AC and DC lines, DC polarity, blown fuses, etc. Traces ground line in AC circuits. Useful as RF indicator, spark plug and cable tester. Has hundreds of other useful applications. Can be used on 60 volts AC to 500 volts AC or DC. List price \$1.00.

#### Radio Chemical Laboratory



20 large 2 oz. bottles contain cements, solvents, contact cleaners, non-slip dial chemicals, lubricants, ins. varnish, cabinet stains, glue, coil dopes, etc. Dealer net cost \$4.90 with FREE RACK.

ORDER FROM YOUR RADIO JOBBER

**GENERAL CEMENT MFG. CO.**  
Rockford, Illinois, U.S.A.



## Are you interested in SOUND MOTION PICTURE PROJECTION?

SUBSCRIBE to INTERNATIONAL PROJECTIONIST, the only magazine published that is devoted exclusively to the mechanical and electrical principles of professional sound motion picture projection. It deals with the arc lamp, film projector, sound track, photoelectric cell, sound amplifier, maintenance and repair of projection equipment, and with every detail of high-calibre, professional motion picture projection. I. P. has the endorsement of leading projection supervisors of the United States and Canada.

INTERNATIONAL PROJECTIONIST  
580 Fifth Ave., N. Y. C.  
Enter my subscription for

1 year—12 issues—\$2  
 2 years—24 issues—\$3  
(Foreign—50c per year extra)

Name .....

Address .....

# A New Type of Service Manual!

## RADIO CIRCUIT MANUAL—1941

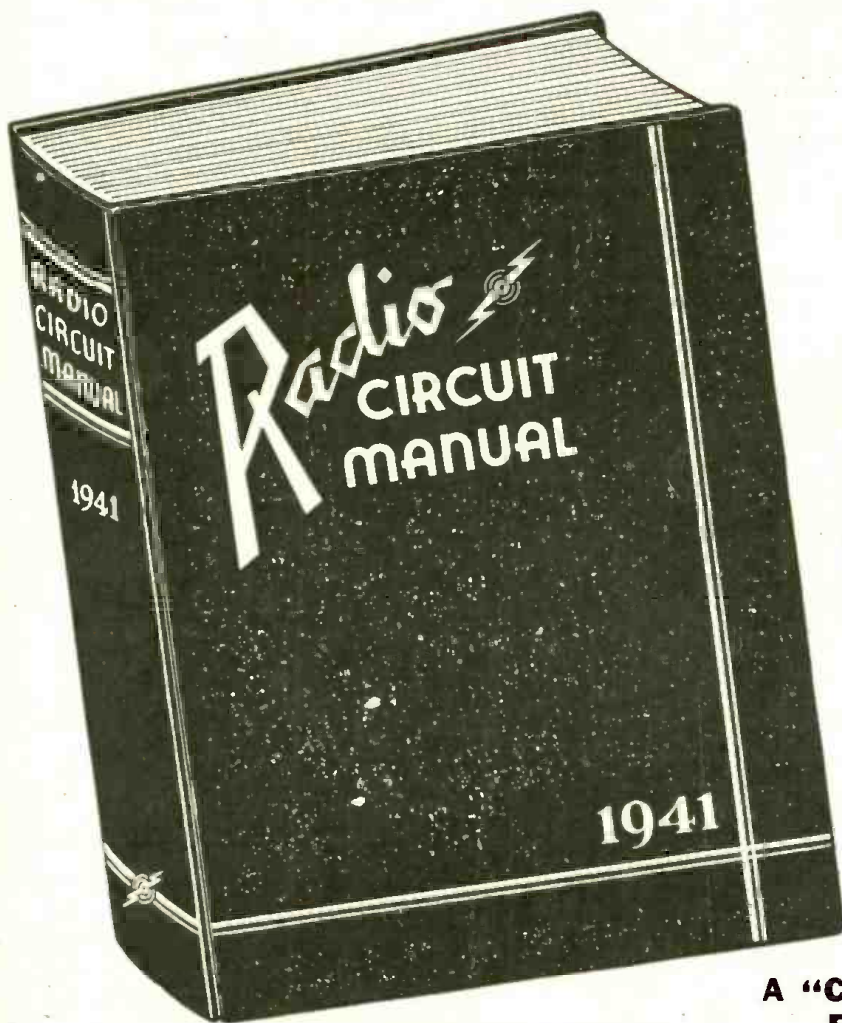

**The Only EDITED Manual  
Ever Published!**

**DIRECTORY OF RECEIVERS MANUFACTURED IN 1940 AND UP TO JUNE, 1941**

**MORE INFORMATION IN HALF THE NUMBER OF PAGES**

The value of a service manual is measured not by the number of pages but by the amount of useful information. Thus, in only 736 pages this Radio Circuit Manual covers over 200 receiver models MORE than does any other competitive manual in twice the number of pages.

HOW DID WE DO IT? . . .

. . . By increasing the size of our page; by discarding non-essential data and editing the balance; by listing only those receivers which the Service Engineer will definitely have to repair (no communications or export receivers, no shortwave sets or amplifiers, no electronic devices, etc.); by many months of hard work based on a definite plan of procedure and a clear understanding of the actual requirements of the Service Engineer. There is no "dead weight" information to add bulk to this Manual. Every word counts. Every minute of reading time is well spent.

### OUTSTANDING FEATURES

- Contains data on more than 1800 receiver models!—more than any other radio service manual.
- Only 736 pages!—less than half the bulk of any other manual and more than 1/3 lighter.
- All information is EDITED!—all non-essential data deleted and the balance checked and correlated with the schematics and sketches.
- 40% larger page permits listing of all information on one page. (A few unavoidable cases excepted.)
- I.F. peaks for all superhet circuits are boldly displayed in black boxes.—none missing, all accurate.
- No space wasted on communications and export receivers, amplifiers, electronic musical instruments, etc.—a 100% Service Engineer's Manual.

### A "CUSTOM-TAILORED" MANUAL FOR SERVICE ENGINEERS

Here, at last, is a Service Manual deliberately PLANNED for the Service Engineer. Instead of a mere hodge-podge collection of service data, as manuals have been in the past, this RADIO CIRCUIT MANUAL is an orderly compilation of essential radio diagrams and service information, carefully edited and uniformly presented for the maximum convenience of the busy Service Engineer. All time-consuming, non-essential data have been weeded out, and the remaining information, vitally important to the rapid and efficient servicing of modern radio receivers, has been laid out in a logical, easy-reading style which cuts time from the day's work. Because of this and other features which are self-evident upon first observation, it has been possible to list all information pertaining to a given model on a single page.

In 736 pages this Manual presents essential service data on over 1800 receiver models;—more than any other existing service manual on the market!

### ONLY ONE MANUAL PER YEAR!

The new technique used in compiling this RADIO CIRCUIT MANUAL—1941 makes it possible to include in a single book all the new receiver models which the radio industry can produce in a single year. This factor alone represents an important saving to all Service Engineers.



← THE OLD TYPE MANUALS—Bulky, heavy, hard to handle, space consuming, less USEFUL data despite greater number of pages.



OUR NEW MANUAL—Lighter, compact, easy to handle, takes half as much room on the shelf, more USEFUL information despite fewer number of pages. →

### MANUALS NOW READY!

RADCRAFT PUBLICATIONS, INC.,  
25 West Broadway, New York, N. Y.

Gentlemen: Enclosed find my remittance of \$10.00, for which send me, POSTPAID, my copy of the RADIO CIRCUIT MANUAL—1941.  
PLEASE PRINT CLEARLY

Name .....

Address .....

City .....

State .....

RC-11-42

(Send remittance in form of check or money order; register your letter if you send cash.)

### ORDER YOUR MANUAL IMMEDIATELY—NOW!

Get your copy directly from us by filling out and mailing the convenient coupon shown at left, or get it directly from your favorite distributor.

736 pages; size 13 3/4 x 10 1/4 x 2 in. thick; loose leaf, leatheroid-covered atif binder; net weight 6 1/2 lbs.

ONLY  
**1000**

### A PERMANENT INSTITUTION

This Radio Circuit Manual—1941 is NOT a one-time proposition. Next year there will be a Radio Circuit Manual—1942, the following year, 1943 and so on indefinitely.—each Manual better than the other as new methods are worked out for expediting and simplifying the work of the practicing Service Engineer.

**RADCRAFT PUBLICATIONS, INC.**  
**25 WEST BROADWAY NEW YORK, N. Y.**

# UNIVERSAL TEST SPEAKER FOR TESTING AUTO RADIOS

By THOMAS D. BIGELOW

HEREWITH are diagrams, operating and constructional data for a "Universal Test Speaker" in which I find not only small in construction cost but versatile and simple in operation. It may be used to check any radio set through the audio transformer or connected direct to the secondary output.

This unit may be housed in a small veneer wood case for portable use, or built into a panel or bench job. No batteries are required for the operation of this tester, which makes it very suitable for portable use as well as less expensive upkeep.

A wide range of tests may be conducted as follows:

In checking the speaker, including voice coil, connect the terminals one and two to the secondary of the audio output transformer. Put switch to "off" position.

In checking "single tube" output, connect the terminals three and five to the plate of

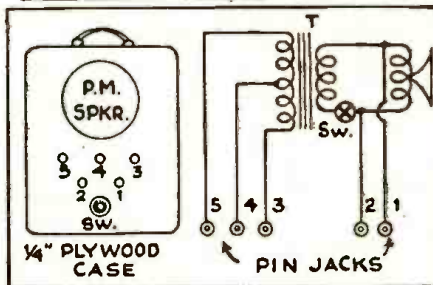
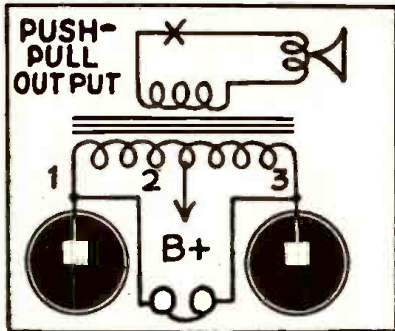
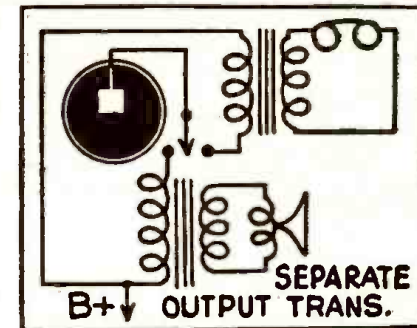
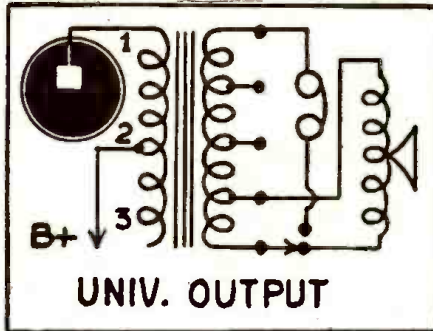

the output tube and "B +". Put switch to "on" position.

In checking "push-pull" outputs, connect the terminals three and five to the plates of the audio outputs and terminal four to "B +", with switch to "on" position.

This unit does a fine job in the servicing of automobile receivers, making it unnecessary to remove the speaker unit of the receiver in the car for repairs to the set alone.

**PARTS LIST**

One 6" or 8" permanent magnet speaker

One Universal Audio Output Transformer  
One Single Pole, Single Through Switch  
Five Tip Jacks and Three Tip Plugs  
Three Insulated Alligator Clips  
Only three test leads needed at any time  
For portable use—one veneer case, approximate size 12"x10"x6"

# AUTO RADIO TEST BOX

By FLOYD D. GOFF

This little unit is very useful on any experimenter's bench. It takes up but little room, being only 9 x 3 1/2 x 3 inches in size. It is a combination condenser substitution box variable resistance and D.C. ammeter. The construction cost is only about four dollars.

The D.C. ammeter is a standard auto meter and can be obtained at any auto supply house for less than fifty cents. It is used when servicing auto sets on the bench.

The potentiometer is a wire-wound type with a current carrying capacity of about .015 amp. The rest of the unit needs no

explaining. It's functions are readily apparent to any serviceman.

I used quarter inch basswood for the case.

**CONDENSER CAPACITIES**

C-1	4 mf.	450 Volt
C-2	8 "	" "
C-3	16 "	" "
C-4	.1 "	600 "
C-5	.05 "	" "
C-6	.02 "	" "
C-7	.005 "	" "
C-8	.001 "	" "
C-9	.0015 "	" "
C-10	.00025 "	" "

(mica)

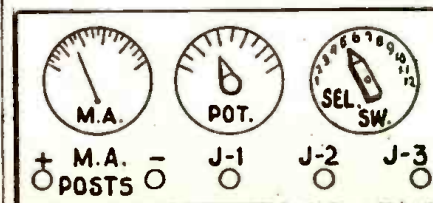
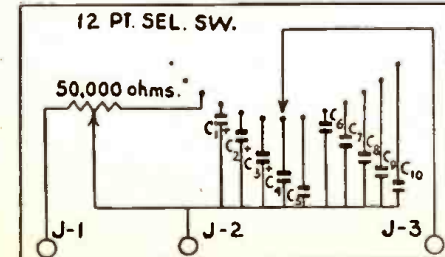

# Are You Making Good in Your New Radio Job?

Here's how you can acquire the ability to "make good" now—and to enjoy security in the years to come.

Hundreds of radiomen have been given responsible jobs throughout the radio industry—jobs in government, broadcasting, manufacturing, aviation—jobs which in many instances require a thorough knowledge of practical radio engineering.

If you are a practical radioman who realizes that fortunate circumstances have placed you in a job requiring technical ability of high calibre . . .

If you are smart enough to know that you will "get by" in your job only so long as a fully qualified man is unavailable . . .

If you have the ambition to make good in your new job and to rise to even a still better job . . . then a CREI home study course in Practical Radio Engineering will help you to acquire the technical knowledge which is demanded by the better, higher paying positions in technical radio.

**WRITE FOR FACTS TODAY!**

Our free booklet and personal recommendations may hold the answer to your success. In your inquiry, please state briefly your background of experience, education and present position.



**CAPITOL RADIO Engineering Institute**  
Dept. RC-11, 3224 16th Street, N. W., Washington, D.C.

# LEARN RADIO TELEVISION

600 LICENSED graduates placed in past 7 years in shipping, broadcasting, aviation, police, etc.; we also teach radio servicing and repairing; new beginners' class now forming; 60-page catalog free; oldest, largest and best equipped.

**MASS. RADIO SCHOOL**  
18 BOYLSTON ST., BOSTON, MASS., Est. 1893

# COMMERCIAL RADIO INSTITUTE

A radio training center for over twenty years. Well equipped. Excellent faculty. Practical resident courses in Defense, Radio Telegraphy, Broadcast, Servicing, Industrial, Television, Aeronautical, Drafting, Mathematics and Studio Technique. Placement bureau. Classes now forming. Catalog upon request.  
Dept. D, 38 West Biddle Street, Baltimore, Md.

# RADIO TECHNOLOGY

RCA Institute offers an intensive two-year course of high standard embracing all phases of Radio and Television. Practical training with modern equipment. Also shorter, specialized courses in Commercial Radio Operating, Radio and Television Servicing, and Aviation Communications. For Free Catalog write Dept. RC-42.

**RCA INSTITUTES, Inc.**  
A Radio Corporation of America Service  
75 VARICK STREET NEW YORK

**RADIO COURSES**

Day and Evening Classes Now Starting

- RADIO OPERATING • RADIO AMATEUR CODE • RADIO SERVICING • RADIO TECHNICIANS

**New York Y.M.C.A. Schools**

4 W. 64th Street New York City

HIGH EFFICIENCY result in Sound National Defense that is why NATIONAL DEFENSE SOUND SYSTEMS are equipped with University Reflex HIGH POWER LOUDSPEAKERS UNIVERSITY LABS. 105 CHARLIE ST. N.Y.C.

*University*

# Radio Patents Digest

## Crystal Oscillator System

No. 2,289,399 issued to Charles W. Winter, Jr., and Edwin M. Hinsdale, Jr., Miami, Fla.

In an oscillation generator and amplifier for radio signalling, the combination of a tube having a grounded cathode, an anode, a screen element and a control element; a first oscillatory circuit comprising a crystal having one side thereof electrically connected directly to said control element and connected through a capacitance to said cathode and the other side of said crystal connected through a capacitance to ground, a second oscillatory circuit comprising a tunable tank circuit having one end thereof connected to said anode and the other end connected directly

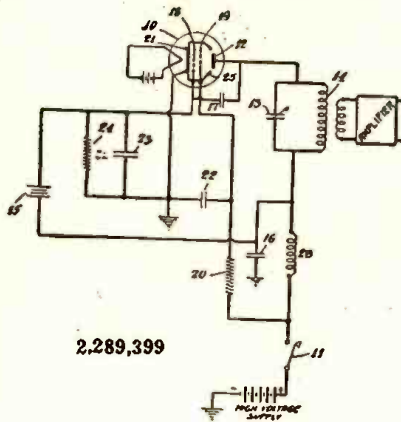

2,289,399

to said other side of said crystal, and a capacitance connected between said anode and said control element for causing said crystal to operate as a parallel resonant circuit and at its resonant frequency, only, and for maintaining the output frequency of said generator and oscillator at the fundamental frequency of said crystal or a multiple thereof, means for maintaining said screen element at radio frequency ground potential and means for maintaining the tube at operating potentials.

## System of Transmission and Reception

No. 2,289,444 issued to Hermann Mayr, Paris, France.

The method of intelligence transmission and reception utilizing in part a common amplifier which comprises generating oscillations locally for the dual purpose of modulation by the signals to be transmitted and for mixing with the received signal energy, amplifying the signals to be

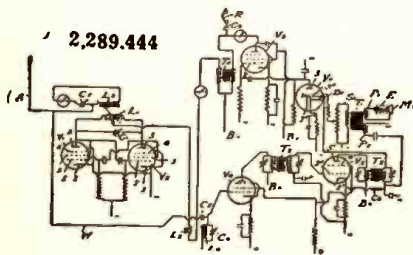

2,289,444

transmitted prior to the modulation of the local oscillations thereby, modulating the local oscillations with the outgoing amplified signals, receiving the incoming signal energy and mixing the locally generated oscillations therewith, and amplifying the received signal energy subsequent to the interaction of said local oscillations therewith, with the same amplifier-executing the first-mentioned amplifying operation.

## Automatic Radio Receiver Apparatus

No. 2,289,417 issued to Robert H. Fisher, New York, N. Y.

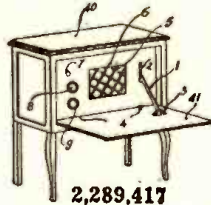

2,289,417

In apparatus of the class described, an enclosure for a radio receiving set or the like, a cover member for said enclosure movable to open and closed positions, a switching means for controlling the operation of said set, an operating element for said cover member, driving means for said operating element, means including a prime mover and an electrical circuit for operating said driving means, and an electromagnetic device in said circuit responsive to the operation of said switching means for closing said circuit to energize said driving means.

## Phonograph

No. 2,289,468 issued to Eugene L. Triman, Chicago, Ill.

A system for electrically reproducing Phonograph records comprising a central station and a plurality of subscribers' stations each connected thereto by a two wire telephone line, means located at each subscriber station including a microphone and a sound reproducer, means located at said central station including a phonograph pickup, a microphone, and a sound reproducer, circuit

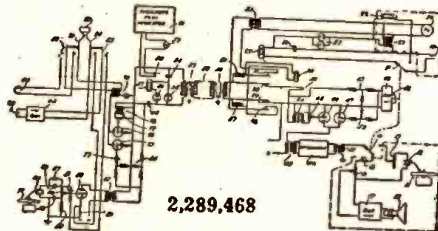

2,289,468

means at each end of said telephone line for interconnecting said means with said line, said circuit means having a two-way channel connected to said line, a one-way channel connected to said sound reproducer, another one-way channel connected to a microphone, a loss pad connected between said microphone channel and said two-way channel, and a second loss pad connected between said microphone channel and said sound reproducer channel, and a phase inverter connected between said two-way channel and said sound reproducer channel.

## Electronic System

No. 2,289,493 issued to Roscoe H. George, West Lafayette, Ind.

An automatic volume control for an amplifying system comprising a signal amplifying channel including at least one thermionic tube for amplifying received modulated radio frequency signal energy, means to demodulate the amplified signal

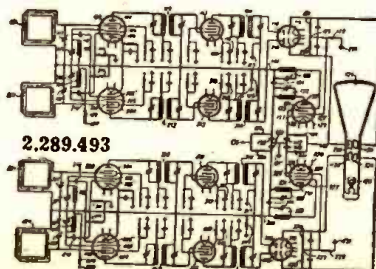

2,289,493

energy, a multi-electrode electron tube, means including predetermined electrodes thereof to develop oscillations of a predetermined frequency, a load circuit connected to the output of said demodulating means across which a signal voltage is developed, means to modulate the intensity of the said developed oscillations in accordance with the intensity of the developed signal voltage, means to rectify and filter the intensity modulated oscillations to produce a voltage variation in accordance with the intensity of the oscillations, and means to control the amplification of said signal amplifying channel in accordance with the intensity of the produced voltage variation.

## Coupled Loop Collector Circuit

No. 2,289,594 issued to William A. Schaper, Cicero, Ill.

A signal-collecting system for use in radio receivers having a first vacuum tube with an input electrode and tunable over a range of frequencies, including a closed fixed-tuned resonant circuit comprising a first exposed inductive element and a capacitor in series and resonant near the low-frequency end of said range, a variably-tuned

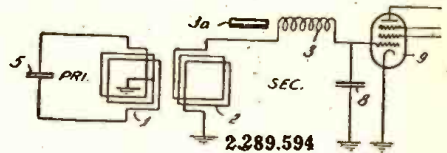

2,289,594

resonant circuit connected to said input electrode and comprising a second exposed inductive element, a second capacitor and an unexposed inductive winding in series, said exposed inductive elements being positioned to produce a small degree of inductive coupling between said circuits, said fixed tuned resonant circuit being coupled to said vacuum tube solely by said inductive coupling, and means for tuning said tunable circuit to resonance with any desired signal within said range solely by variation of the inductance of said unexposed inductive winding.

## Therapeutic Current and Means for Producing the Same

No. 2,295,585 issued to Robert J. Lindquist, Los Angeles, Calif.

In a system of producing a therapeutic current of the character described, the combination of: a power circuit; and means for controlling active and inactive periods in said power circuit, said means comprising a switch, and means for moving said switch between off and on positions comprising an electromagnet connected to said switch so as to actuate the same, a ther-

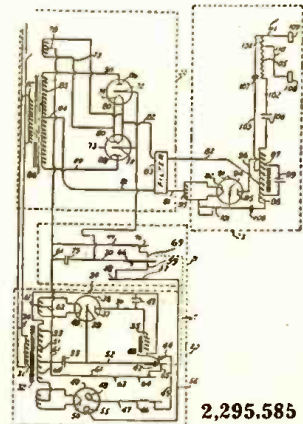

2,295,585

mionic device having its filament and plate connected in series with said electromagnet, and blocking circuit means connected to the grid of said thermionic device, said blocking circuit means having cooperating controlling elements whereby a blocking potential is periodically applied to said grid to control the flow of current through said electromagnet.



# Book Reviews

**PRINCIPLES OF RADIO**, by Keith Henney. Published by John Wiley & Sons. Stiff cloth covers, size 6x9 inches, 549 pages, illustrated. Price \$3.50.

The fourth edition of Keith Henney's *Principles of Radio* has just been issued, thirteen years after its first printing. Although the progress made in radio in the intervening years has been phenomenal, the principles have remained essentially the same. Some new material has been added and an attempt has been made to bring the book up to date.

One can understand Mr. Henney's reluctance to alter appreciably either the subject matter or the plan of presentation—the book has been eminently successful not only among self-taught radio students but also in trade schools and even in colleges. The book is now being used to train men for military and civilian radio duties. Mr. Henney has resisted suggestions that he make the mathematics more mathematical, and he refused also to eliminate the mathematics.

It is a little surprising to find some of the old, original diagrams in this edition. When a discussion of a circuit pertains to tubes drawing a quarter of an ampere at five volts; when an audio amplifier is shown having three cascaded transformer-coupled stages—these are unmistakable signs of old age.

Perhaps the author believed that in some cases such changes would "spoil" the analysis, and that the analysis may be sufficiently important because of its constructive method of making the student "think out" a problem. We believe, however, that an equally practical analysis of a more up-to-date problem could have been substituted without departing from the scope of the author's intention.

The book is good—but only as good as it previously was, rather than as good as it might be if Mr. Henney would rewrite the practical material. The theoretical matter is excellent for the radio beginner. We have recommended this book since it was first published—and probably will continue to do so—for its intelligent way of putting its indelible imprint on the minds of radio newcomers.

**ULTRA HIGH FREQUENCY TECHNIQUES** by J. G. Brainerd, G. Koehler, H. J. Reich, and L. F. Woodruff. Published by D. Van Nostrand Co., Inc. Stiff cloth covers. Size 9½ x 6 ins. 570 pages. Price \$4.50.

This textbook printed in offset, was prepared to cover the subject in compact manner, for engineers and physicists who are designing and developing U.H.F. apparatus for wartime uses. It will be just as valuable in peacetime however, because it is a matter of viewing the field rather than concentrating on certain topics for special purposes.

The book is basically concerned with the theory underlying the various techniques, and briefly reviews circuit theory and electron tubes. Considerable material from ordinary communication work is also embraced so the student can work continuously without referring to the standard texts.

There are many line drawings and block diagrams illustrating the various circuits

and hook-ups, characteristics, energy fields, etc. Subjects covered are: Linear Circuit Analysis; Fundamentals of Tubes and Power Supplies; Amplification; Trigger Circuits (Gates); Pulse-sharpening Circuits and Oscillators; Cathode-Ray Tubes and Circuits; Modulation; Demodulation; Radio Receivers; Transmitters; U.H.F. Generators; Transmission Lines; Radiation and Propagation; Hollow Wave Guides; Laboratory Guide.

**ACOUSTICS OF MUSIC** by Wilmer T. Bartholomew. Published by Prentice-Hall Inc. Stiff cloth covers, size 9½ x 6 ins. 242 pages. Price \$3.00.

Here is an excellent book for those interested in good quality reproduction from loudspeakers of radios and phonograph amplifiers, as well as those who play a musical instrument.

Mr. Bartholomew, who is a member of the staff of the Peabody Conservatory of Music, bridges the gap from theoretical or physical concepts of music to actual auditory response and the effects of sound on our ears. Such a work has long been needed. Without mathematics he has brought the subject up to date, weaving in the practical aspects of the art as explained by modern research.

The first chapter, on the nature of vibrations, is highly illuminating, as it pictures fundamentals, and overtones (or partials as they are sometimes called), in such a way that it is easy for the radio experimenter to see the analogy in superheterodyne theory, oscillators, electronic organs distortion, etc., and other alternating-current phenomena.

He explains, for instance, how vowel sounds may be produced artificially and a robot made to say "Saskatchewan." Also how over-intensification of amplitude, and over-complexity of a wave-form, can produce distortion and noise.

The three basic attributes of a sound wave—pitch, timbre and amplitude—are each taken up and thoroughly discussed in an interesting manner, so the reader will find explanations for a great many things which heretofore were only slightly understood, or taken for granted without comment. For instance, research has shown that a 75-piece orchestra is louder (has a higher decibel rating) than a pipe organ. That the most powerful male voice is only three one-hundredths of a watt; the average speaking voice 25 millionths of a watt. Or to consider the pipe organ alone, although a 10,000 watt motor may be used to blow it, only 13 watts appears as sound energy!

Also in the matter of resonance and reverberation, it may be learned why a "pure" tone may not be the best "musical" tone. And why Wagnerian opera gained favor in certain cities, while Italian opera had to remain in Italy. Simply because of reverberation characteristics of the music halls of the respective countries.

Other chapters in the book discuss sound waves and their characteristics, stretched strings, air-columns, percussion, the voice, harmony, noise, hearing, electronic recording, reproducing and synthesizing of sound.

(Continued on following page)

"The new edition is first-rate..."



With or without the aid of a teacher, with or without technical training, "Henney" is on hand in a new edition ready to guide you in easy stages to a working knowledge of radio. Gives fundamentals in easy-to-understand language, and applies them to modern problems.

Fourth Edition

## Principles of RADIO

By KEITH HENNEY  
Editor, ELECTRONICS

What's new: The fourth edition of "Henney" contains the latest on detection, ultra-high frequencies, television, radio-frequency amplifiers, vacuum tube detectors, frequency modulation, antennas, etc. It's all there—from principles of electricity to their application to radio practice.

"Principles of Radio" has been chosen as the textbook for the course sponsored by the U. S. Office of Education and the U. S. Signal Corps.

549 Pages 316 Illustrations  
6 by 9—\$3.50

-----ON APPROVAL COUPON-----  
 JOHN WILEY & SONS, INC.  
 440 Fourth Avenue, New York, N. Y.  
 Kindly send me a copy of Henney's "Principles of Radio" on ten days approval. If I decide to keep the book I will remit \$3.50; otherwise, I will return the book postpaid.  
 Name .....  
 Address .....  
 City and State .....  
 Employed By ..... RC-11-42

## MATHEMATICS FOR RADIO

Two volumes, prepared for home study. Book I (314 pp.) covers the algebra, arithmetic, and geometry; Book II (329 pp.) covers the advanced algebra, trigonometry, and complex numbers necessary to read technical books and articles on radio.

MAEDEL PUBLISHING HOUSE Room 102  
593 East 38 Street, Brooklyn, New York

Send me MATHEMATICS FOR RADIO AND COMMUNICATION as checked below. I enclose payment therefor with the understanding that I may return the book(s) within 6 days in good condition and my money will be refunded.

Name .....

Address .....

- Book I at \$3.75 plus 6c postage
- Book II at \$4.00 plus 6c postage
- Books I and II at \$7.75 postage prepaid

Foreign and Canadian prices: 25c per volume higher

## Home-Study Course in SENDING and RECEIVING RADIO CODE

• with all necessary instructions and practice material

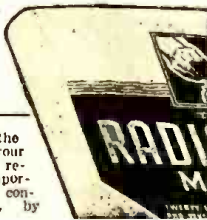

Use it to learn code from the very beginning—to raise your speed to highest professional requirements—to master this important and better-paying skill conveniently and inexpensively, by home study.

Just Out—Arthur R. Nilson's

## RADIO CODE MANUAL

Price, only \$2.00

Here is a complete course in radio code—how to send it and how to read it—in practical form for self-study or classroom use. Gives 20 lessons, beginning with simplest code characters and leading up to the handling of actual messages and distress messages, weather reports, and distress messages.

### IT SHOWS YOU:

- how to make your own practice apparatus
- how to fix the code characters in your mind
- how to practice them for quickest progress
- how to develop sending and receiving speed
- how to get past the "plateau of slow learning"
- how to handle messages
- how to judge your rate of improvement

The 20 lessons are a carefully worked out, progressive series, very similar to courses offered in Navy, Signal Corps, and other radio schools. Each lesson contains instructions, pointers, and ample practice material. Besides this direct drill in code, the book also gives you, in 7 other chapters, a great deal of helpful information on training yourself in the code and on becoming a good operator generally.

### 10 DAYS' FREE TRIAL—SEND THIS COUPON

McGraw-Hill Book Co., 330 W. 42 St., N. Y. C.  
Send me Nilson's Radio Code Manual for 10 days' examination on approval. In 10 days I will send \$2.00, plus few cents postage, or return book postpaid. (Postage paid on cash orders.)

Name .....

Address .....

City and State .....

Position .....

Company .....

## Radio Servicemen and Dealers!!

Write for our new circular of radio parts and accessories. All items in stock, immediate delivery, no waiting.

### SIGMON RADIO SUPPLY

708 Bislely Ave., Charleston, W. Va.

## OPPORTUNITY AD-LETS

Advertisements in this section cost 15 cents a word for each insertion. Name, address and initials must be included at the above rate. Cash should accompany all classified advertisements unless placed by an accredited advertising agency. No advertisement for less than ten words accepted. Ten Percent discount six issues, twenty percent for twelve issues. Objectionable or misleading advertisements not accepted. Advertisements for December, 1942, issue must reach us not later than November 10, 1942.

Radio-Craft • 25 W. B'way • New York, N. Y.

HEK-O-KUT, RB12 recording mechanism 120 lines per inch, with BRUSH high fidelity cutter. Ilek-O-Kut base and 12" turntable. OUTSIDE BELT drive at 33 1/3 and 78 r.p.m. powerful 1/20 h.p. D. E. motor, write for complete information. I. Schultz, 1152 E. 224 Street, New York City.

## RADIO KITS—Ready To Wire

Tremendous quantity of standard parts, suitable for kits. Complete in every detail. All hardware, tubes, parts. Diagrams furnished. Latest parts catalog—FREE.

McGEE RADIO, R-2055, Kansas City, Mo.

## Book Reviews

**PRACTICAL MATHEMATICS FOR HOME STUDY** by C. I. Palmer and S. F. Bibb. Published by McGraw-Hill Book Co. Flexible covers. Size 7 1/4 x 5 ins. 697 pages. Price \$4.00.

This is the third edition of a standard work, an "old friend," brought up to date. This text from its beginning was intended for the adult student, the man who works in various trades during the day and has to study at home at night.

Especially now in these times when men in the service and men about to join, are brushing up on their "math" in order to obtain specialist ratings in special jobs, is a book like this so valuable.

So much of the theory of radio, navigation, meteorology, etc., relies on mathematics and physics (which itself is full of mathematics), it becomes necessary for a man intending to be a specialist to re-master the basic studies.

The text opens with arithmetic, giving a good review in numbers, how to attack a problem, how to divide easily, cancel, and apply the rules for rapid calculation.

Then common fractions are taken up. (How many of us stumble over these and decimals!) If you study this chapter conscientiously fractions won't bother you anymore.

Decimal fractions are next taken up with explanation of accuracy, as applied to readings of instruments, measurements, scales, etc.

Systems of weights and measures are covered thoroughly, including a good explanation of the metric, with which a great many are unfamiliar.

Percentage, another bugaboo for some, is dealt with concisely and coherently.

Ratio and proportion, which is so important in physics and radio, is explained so clearly the student should be able to approach the advanced subjects with confidence.

Square root and squares are presented simply and directly.

Part II of the book covers plane and solid geometry completely and thoroughly. Part II takes up algebra, from introductory problems, through equations and operations to exponents, quadratics and logarithms. Part IV, Trigonometry, the last portion of the text, brings the student up to the point where he is ready for analytic geometry and the calculus. All parts of trigonometry are covered: Functions, angles, tables, solutions of right and other triangles, interfunctional relation, graphs of sines, cosines, etc., and applications to more difficult problems in everyday work.

A group of always-useful tables is incorporated in the back, thus giving the student a complete work, making it really easy for him to study at home, without an instructor. And best of all the book is printed in large easy-to-read type.

## A SIGNAL MODIFIER FOR RECEIVING CODE CLEARLY

(Continued from page 113)

### PARTS LIST

- R1—2 megohms, 1/2 watt
- C1—1 mf. paper, 400 volts
- T1—Filament transformer (UTC FT-2)
- T2—Audio transformer (UTC R-33)
- T3—Push-pull input transformer (UTC R-34)
- N—1/4 watt neon bulb
- Sw—S.P.S.T. switch
- 6X5, 6C5 (tubes)
- Chassis 7 x 7 x 2 inches

## RADIO ENGINEERING DEGREE IN 2 1/2 YEARS

• Complete Radio Engineering Course in 27 months. Bachelor of Science Degree. Radio (television, talking pictures and the vast electronic field) offers unusual opportunities. War needs call for the engineer. Demand exceeds the supply. Courses also in Civil, Electrical, Mechanical, Chemical, Aeronautical Engineering; Business Administration, Accounting, Secretarial Science. Tuition; living costs low. Distinguished for technical 2 1/2 year courses. Special preparatory department for those who lack required high school work. Enter January, March, June, September, 39th year. Write for catalog. 2411-2 COLLEGE AVE. ANGOLA, IND.



## TRI-STATE COLLEGE

Correspondence Courses in RADIO and ELECTRICAL ENGINEERING

**ELECTRICAL ENGINEERING** Get good grasp of wide electrical field. Prepare yourself at Low Cost, for secure future. Modern, simplified, you can understand quickly. **RADIO ENGINEERING** Extra fine course in radio, publishing you to be super-service man, real vacuum tube technician. Exper. kits furnished. Diploma on completion. Tuition, \$25. either course. Deferred payment plan. **FREE** Get copies of school catalog, student magazines, complete details. **SEND NOW!**

LINCOLN ENGINEERING SCHOOL Box 931-C48, LINCOLN, NEBR.

## Index to advertisers

Audel & Co., Theo.	70
Audiograph	103
Burstein-Applebee Co.	117
Candler System Co.	117
Cannon Co., C. H.	103
Capitol Radio Engineering, Inc.	125
Chartered Institute of America	117
Commercial Radio Institute	125
General Cement Mfg. Co.	123
Gold Shield Products	111
Hallcrafters, Inc. ... Inside Back Cover	
Harrison Radio	121
Henry Radio	107
Hudson Specialties Company	120
International Projectionist	123
Korrol Mfg. Co.	117
Lancaster, Allwine & Rommel	111
Lincoln Engineering School	128
Maedel Publishing House	127
Mass. Radio School	125
McGee Radio	128
McGraw-Hill Book Co.	128
Meissner Manufacturing Co.	97
National Radio Institute	65
National Union Corp.	86
Nelson Co.	103
N.Y.-YMCA Schools	125
Opportunity Adlets	128
Peerless Sound & Radio	118
Prentice-Hall	80
Radio Corp. of America	67
Radcraft Publications, Inc.	114, 115, 122, 124
RCA Institutes	125
RCA Manufacturing Co. ... Back cover	
Radio Publications	116
Radio-Television Institute	123
Radio & Television	109
Radolek Co.	69
Readrite Meter Works	111
Sigmon Radio Supply	128
Schultz, I.	128
Solar Manufacturing Co.	103
Sprague Products Co.	93
Spraberry Academy of Radio	81
Supreme Instruments Corp.	103
Sylvania Electric Products, Inc.	68
Technifax	81, 99
Triplett Electric Instruments Co. ... Inside Front Cover	
Tri-State College	128
University Laboratories	125
Wiley & Sons, John	127
X. L. Laboratories	103

(While every precaution is taken to insure accuracy, we cannot guarantee against the possibility of an occasional change or omission in the preparation of this index.)

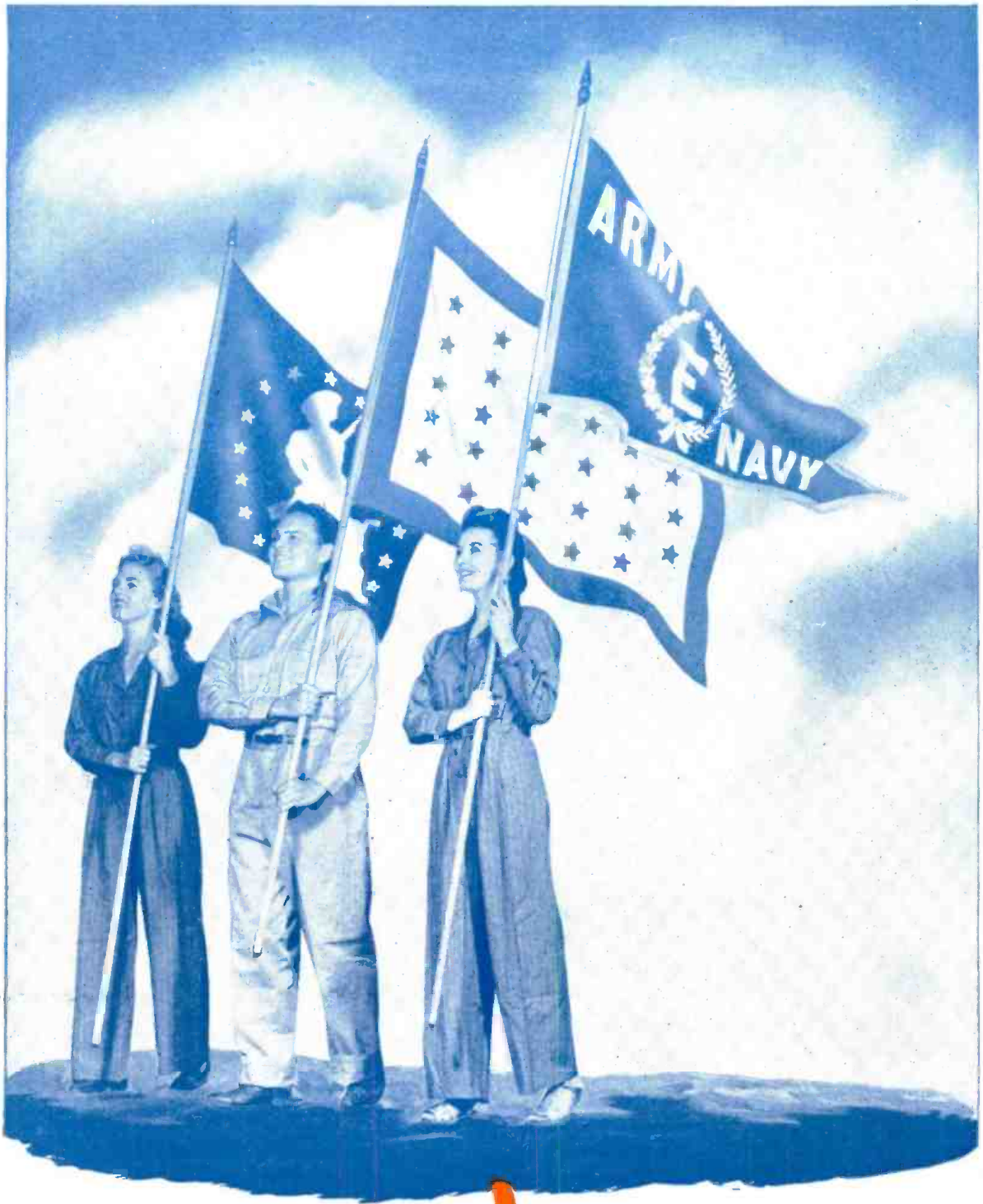

## **Battle Flags !**

All of us at the Hallicrafters are both proud and humble to have important assignments in defeating America's enemies.

That our efforts have justified the award of the famous Army-Navy "E" flag is a great honor. We shall keep it proudly flying.

**all of the hallicrafters**



Advice from "out there" for radio designers "back here"

## KEEP IT SIMPLE!

On the hot sands of Africa, or in the wastes of Alaska—our men turn with calm confidence to that piece of radio equipment you designed.

If anything goes wrong, there's little time for complicated repairs... and often nothing to replace an injured "special" unit.

How can you best design radio equipment for today's far-flung battlefronts?

Don't over-design! Make it good. But keep it simple. There are many new and special types of tubes available. RCA makes the finest of them, and will continue to make them in order to assist designers.

But if you possibly can—avoid them. The men sitting by that piece of radio equipment have to keep it working—perfectly—all the time. Their repair posts may not have the "special" parts you included in the design. The instrument, so important to the lives of thousands, may stand idle when they need it most.

So use standard equipment whenever you can. Standard crystals, transformers, condensers, and tubes. They're prepared to handle that. They'll be able to repair them and keep them working.

And they'll be mighty grateful to you.

BUY  
U. S. WAR  
BONDS

This advertisement appears in *Electronics*, *QST*, and *Proceedings of the Institute of Radio Engineers*.

The advertisement above—directed to designers of military radio equipment—is one of a series run by RCA as a contribution to America's war effort. It stresses the need for *standardization and simplification* in the design of equipment that must be "serviced" under difficult conditions, thousands of miles from home.



**RADIO TUBES**  
RECEIVING TUBES • POWER TUBES • CATHODE RAY TUBES • SPECIAL PURPOSE TUBES

Perhaps engineers and designers are among your customers. If so, the message above is worth repeating. Full-size reprints of the original advertisement are available on request. Write RCA Manufacturing Co., Inc., Camden, N. J., Dept. 2-3.

BUY U. S. WAR BONDS EVERY PAYDAY!



RECEIVING TUBES

**RADIO TUBES**  
POWER TUBES • CATHODE RAY TUBES  
SPECIAL PURPOSE TUBES