

RADIO'S GREATEST MAGAZINE

# RADIO-CRAFT

with  
**POPULAR  
ELECTRONICS**  
★



RADIO PLANE-ROBOT  
SEE PAGE 721

SEPTEMBER

25¢

CANADA 30¢

1943

OVER 100 ILLUSTRATIONS

# FIX ANY RADIO

## Amazing New Invention



Find radio faults with a new simplified method. Repair radios in minutes instead of hours. Revolutionary, different *Comparison* technique permits you to do expert work almost immediately. Most repairs can be made without test equipment. Simple point-to-point, cross-reference, circuit suggestions locate faults quickly and easily.

**COMPLETE**  
**\$1.50**  
ONLY  
**SPECIAL OFFER**  
**READ THE DETAILS**

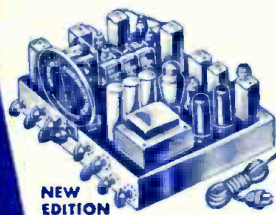

### REPAIR ANY RADIO IN MINUTES

Locate the source of trouble in any radio without equipment. Make needed tests, measure voltage, trace the signal, by using only a resistor, small condenser, and a crystal detector. Inject signals without any signal generator. Test parts by the new *Comparison* method. Test tubes without equipment. Repair any radio expertly following illustrated, simplified plans. Improve your radio servicing ability. Examine the plan without obligations—without risk. Send coupon.

**FOR BEGINNERS OR EXPERTS**  
Learn important short-cuts in trouble-shooting; find any radio fault with ease. Follow the comparison tests given on 16 large trouble-shooting blueprints. Over 1,000 practical repair hints. Hundreds of simplified tests using a 5c resistor, and a filter condenser. Covers every radio set—new and old. Introductory material for beginners and to serve as a review for experienced radio men. Also several chapters on test equipment. Presented in manual form, 112 illustrated pages, 8½ x 11 inches. Entire plan is stark new and will help you get ahead in radio quickly.



**PRACTICAL USEFUL FACTS AND HINTS**  
Hundreds of service hints, trouble-shooting ideas, simplified tests, repair suggestions, and alignment methods are included. Benefit by the experience of others. Use the most practical method for finding the fault and making the repair. Save time on every job.

### Other Supreme Publications

#### PRACTICAL RADIO FOR WAR TRAINING

This new, 1943 manual will clarify the important radio facts, explain the principles which may have puzzled you, and point the way to faster radio repairing. You will find hundreds of practical hints for mounting parts, testing components, trouble-shooting, using instruments. Needed useful theory in each chapter is followed with practical applications. This is the book that will help you repair radios faster, or obtain a good radio War-job, or get ahead in the Armed Forces. Use this timely book as your ready reference for finding the right answer to every radio problem. Written by M. N. Beitman, 336 large pages, 6x9 inches. Printed on thick, enamel paper. Almost 300 illustrations and diagrams to help you. Seal leatherette cover. Attractive manual-binding. Price only **\$2.95**

#### How to MODERNIZE Radios for Profit

Cash-in by improving audio circuits, modernizing cabinets, adding features usually found on late model sets. Practical job-sheets with schematics and photographs make the work easy. You are told how to obtain modernization work, what to charge, and how to complete the job quickly and efficiently. The complete, large size, 8½ x 11 in. manual is priced at only **\$1.00**



#### MOST-OFTEN-NEEDED RADIO DIAGRAMS

The most popular radio diagrams available in low priced manuals. Large size: 8½ x 11 inches.  
1942 Manual, Volume 5, 204 pages...  
1941 Manual, Volume 4, 192 pages...  
1940 Manual, Volume 3, 208 pages...  
1939 Manual, Volume 2, 192 pages...  
1926-38 Manual, Volume 1, 244 pages, alignment, hints, parts lists.....  
**\$2.00** each NET  
**\$2.50**



#### PRACTICAL RADIO MATHEMATICS

Introduces and explains the use of arithmetic and elementary algebra in connection with units, color code, meter scales, Ohm's Law, alternating currents, ohmmeter testing, wattage rating, series and parallel connections, capacity, inductance, mixed circuits, vacuum tubes, curves, the decibel, etc., etc., and has numerous examples. Net. **25c**



#### FIX MOST SETS WITHOUT TESTERS

Follow the COMPARISON technique and repair 4 out of 5 sets without equipment. Speed up your work; locate faults quickly; make repairs efficiently. Be fair with yourself and try this new plan without obligation. Take advantage of our "no-risk" trial. Send coupon today. Use this time-saving, money-making radio servicing technique for 10 days without any obligations. See how quickly you will learn these helpful methods. Save time on every radio job every day. Learn new short-cuts in radio servicing. Get ahead in Radio. Amaze others with your ability to find radio faults and make repairs. Prepare for higher rank and better pay in the Army. Act today.



#### MONEY-BACK GUARANTEE

You must be entirely satisfied or your money will be refunded without a question. The training will more than pay for itself on the first radio job or with higher rank in the Army. Examine and use this unique plan for 10 days at our risk. Send coupon right now—use the plan this week.

### SUPREME PUBLICATIONS

328 S. Jefferson St., Chicago 6, Ill.

Ship my copy of the complete Simplified Radio Servicing by COMPARISON Method manual. I must be entirely satisfied or you will refund my total remittance.

- I am enclosing \$1.50, full price. Send postpaid.
- Send C. O. D. I will pay the mailman \$1.50 and a few cents postage.
- Also send other Supreme Publications books as listed in letter.

Name.....

Address.....

(Use Coupon or Send Order in a Letter)

**SEE YOUR JOBBER OR SEND COUPON**



J. E. SMITH, President  
National Radio Institute, Established 28 Years

He has directed the training of more men for the Radio Industry than any other man in America.

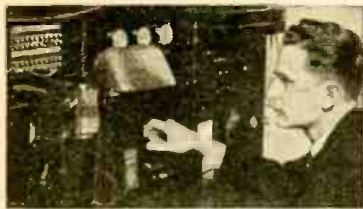

The 915 U. S. Broadcasting Stations give steady jobs to thousands of Radio Technicians, Operators, with average pay among the country's highest paid industries.



Radio Repairing is a booming business today because no new Radios are being made. Many make \$50 a week in full time jobs—others \$5, \$10 a week EXTRA for spare time work!



Civilian Radio Operators are needed for good Government jobs and in Aviation Radio, Police Radio, Commercial Radio. Now is a good time to get started in these fields.

### I Trained These Men



Chief Operator Broadcasting Station

"Before I completed your lessons, I obtained my Radio Broadcast Operator's license and immediately joined Station WMPG where I am now Chief Operator."  
HOLLIS F. HAYES, 327 Madison St., Lapeer, Mich.

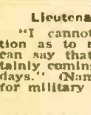

Lieutenant in Signal Corps

"I cannot divulge any information as to my type of work but I can say that N.R.I. training is certainly coming in mighty handy these days." (Name and address omitted for military reasons.)



\$10 a Week in Spare Time

"I repaired some Radio sets when I was on my tenth lesson. I really don't see how you can give so much for such a small amount of money. I made \$600 in a year and a half, and I have made an average of \$10 a week just spare time."  
JOHN JERRY, 1337 Kalamath St., Denver, Colorado.

# I will send you a Lesson Free to show how I train you at home in spare time for Good Jobs in Radio

Mail the Coupon for a FREE lesson from my Radio Course. It shows how N.R.I. trains you for Radio at home in spare time. And with this sample lesson I'll send my 64-page, illustrated book, "WIN RICH REWARDS IN RADIO." It describes the many fascinating jobs Radio offers, tells how you can train for them at home in spare time!

**More Radio Technicians and Operators Now Make \$50 a Week Than Ever Before**

There's a big shortage of capable Radio Technicians and Operators because so many have joined the Army and Navy. Fixing Radios pays better now than for years. With new Radios out of production, fixing old sets, which were formerly traded in, adds greatly to the normal number of servicing jobs.

Broadcasting Stations, Aviation and Police Radio, Ship Radio and other communication branches are scrambling for Operators and Technicians to replace men who are leaving. You may never see a time again when it will be so easy to

get started in this fascinating field. The Government too needs hundreds of competent civilian and enlisted Radio men and women. Radio factories, now working on Government orders for radio equipment, employ trained men. And think of the NEW jobs Television, Frequency Modulation, Electronics and other Radio developments will open after the war! This is the sort of opportunity you shouldn't pass up.

**Many Beginners Soon Make \$5, \$10 a Week Extra in Spare Time**

There's probably an opportunity right in your neighborhood to make money in spare time fixing Radios. I'll give you the training that has started hundreds of N.R.I. students making \$5, \$10 a week EXTRA within a few months after enrolling. The N.R.I. Course isn't something just prepared to take advantage of the present market for technical books and courses. It has been tried, tested, developed, perfected during the 28 years we have been teaching Radio.

**Find Out What N.R.I. Can Do for YOU**

MAIL THE COUPON for FREE sample lesson and my 64-page book. You'll discover things you never knew about Broadcasting, Radio Servicing, Electronics, other interesting Radio fields. You'll read letters from many men I trained. You'll see the many fascinating jobs Radio offers and how YOU can get started. And you'll have my free lesson to KEEP. There's no obligation—no salesman will call. Just MAIL THE COUPON in an envelope or paste on a penny postal!—J. E. SMITH, Dept. 3JX, National Radio Institute, Washington, 9. D. C.

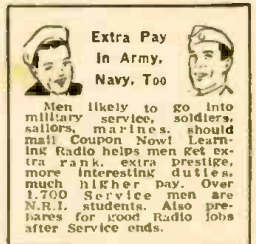

Extra Pay In Army, Navy, Too

Men likely to go into military service, soldiers, sailors, marines, should mail Coupon Now! Learning Radio helps men get extra rank, extra prestige, more interesting duties, much higher pay. Over 1,700 Service men are N.R.I. students. Also prepares for good Radio jobs after Service ends.

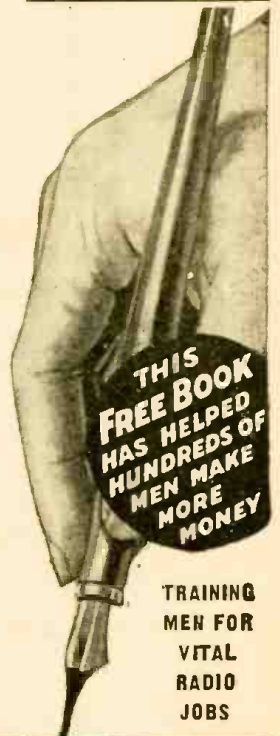

TRAINING MEN FOR VITAL RADIO JOBS

### FREE LESSON

I'll send you a FREE lesson, "Getting Acquainted with Receiver Servicing," to show how practical it is to train at home for Radio. It's a valuable lesson. Keep it—use it—without obligation. Tells how Superheterodyne Receivers work—why Radio Tubes fail—how to fix Electrodynamic Speakers, Output Transformers. Gives hints on I.F. Transformer repair—how to locate defective soldered joints—Antenna, Oscillator Coil facts—Receiver Servicing Technique, etc., etc. 31 illustrations.

### Good for Both 64 PAGE BOOK SAMPLE LESSON Free

J. E. SMITH, President, Dept. 3JX, National Radio Institute, Washington, 9. D. C.

Without obligating me, mail your Sample Lesson and 64-page Book FREE. I am particularly interested in the branch of Radio checked below. (No salesman will call. Write plainly.)

- |  |  |
|--|--|
| <input type="checkbox"/> Radio Service Business of My Own    | <input type="checkbox"/> Aviation Radio                  |
| <input type="checkbox"/> Service Technician for Radio Stores | <input type="checkbox"/> Operating Broadcasting Stations |
| <input type="checkbox"/> Spare Time Radio Servicing          | <input type="checkbox"/> Army, Navy Radio                |
| <input type="checkbox"/> Gov't Civilian Radio Job            | <input type="checkbox"/> Operating Police Radio Stations |
|  | <input type="checkbox"/> Operating Ship and Harbor Radio |

(If you have not decided which branch you prefer—mail coupon for facts to help you decide.)

Name ..... Age .....  
Address .....  
City ..... State ..... 4FR



# RADIO-CRAFT

with  
Popular Electronics

★  
HUGO GERNSBACK  
Editor-in-Chief

FRED SHUNAMAN  
Associate Editor

G. ALIQUO  
Circulation Manager

## Contents SEPTEMBER, 1943 Issue

VOLUME XIV -- NUMBER 12

Editorial: New Radio Inventions in the Post-war World  
by Hugo Gernsback 709

The Radio Month in Review..... 710

### POPULAR ELECTRONICS

Popular Electronics, Part VIII..... by Raymond F. Yates 712

Radio Scale..... 714

Square-Wave Generator..... by Warren Miller 715

Thyratron Rectifiers..... 716

### WARTIME RADIO

Waves..... 718

Talkie for Navy Divers..... by Bob Carman 719

Signal Corps Headset..... 720

Radio Plane Robot (Cover Feature)..... 721

Army Field Portables..... 722

### SERVICING

Repairing AC Meters..... by F. J. Lingel 723

RADIO SERVICE DATA SHEET:  
No. 327 Farnsworth Radio Models DC-90, DK-91, DK-92, DK-93 724

Output Transformers..... by Fred Shunaman 726

### RADIO TRAINING

Radio Waves and Radio Antennas, Part I.... by Eugene P. Bertin 728

### SOUND

Fixed Bias Amplifiers..... by Dean S. Edmonds, Jr. 730

Pick-Up Performance, Part I..... by Ted Powell 732

### TEST INSTRUMENTS

Ohmmeters are Handy..... by Jack King 733

Capacitester for Dynamic Checks..... by Roy R. Maxson 734

### CONSTRUCTION

"Falcon-4"..... 735

Barb-Wire Telephone..... by Fred H. Randolph 736

Radio Checker for Wartime..... R. E. Crago 736



### DEPARTMENTS

RADIO SERVICE DATA SHEET (See Servicing)..... 724

Servicing Notes..... 727

The Listening Post..... 737

Latest Radio Apparatus..... 740

Question Box..... 742

Radio Hook-ups..... 744

Radio Kinks..... 746

Mailbag..... 764

Book Reviews..... 767



Published by Radcraft Publications, Inc. Publication office: 29 Worthington Street, Springfield 3, Mass. Editorial and Advertising Offices: 25 West Broadway, New York City 7. Chicago Advertising Office: RADIO-CRAFT, 520 North Michigan Avenue, Chicago, Ill.

RADIO-CRAFT is published monthly, on the first of the month preceding that of date; subscription price is \$2.50 per year in U. S. (In foreign countries, 75c additional per year to cover postage; Canada, 50c additional.) Entered at the post office at Springfield as second-class matter under the act of March 3, 1879. All communications about subscriptions should be addressed to: Radio-Craft, 25 West Broadway, New York 7, N. Y.

Notice of CHANGE OF ADDRESS should reach us at least one month in advance. Be sure to give your OLD ADDRESS as well as the new, as without the old address we cannot find your name in our files.



#### Foreign Agents:

London—Gorrings's American News Agency, 9A Green St., Leicester Square, W. C. 2, England.

Melbourne—McGill's Agency, 179 Elizabeth St., Australia.

Dunedin—James Johnston, Ltd., New Zealand.



Text and illustrations of this magazine are copyright and must not be reproduced without permission of the copyright owners.



Copyright 1943 Radcraft Publications, Inc.

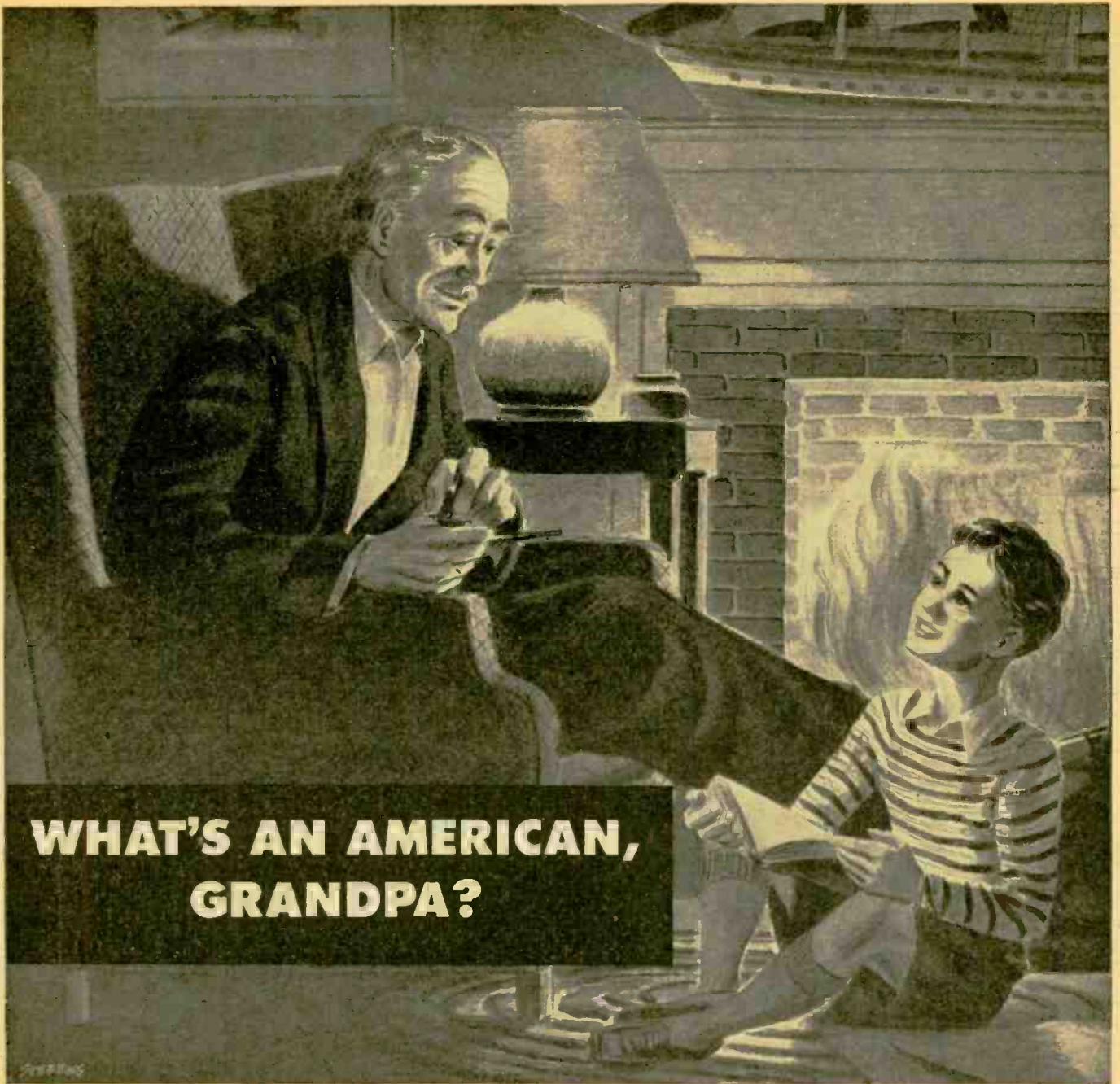

## WHAT'S AN AMERICAN, GRANDPA?

**S**on, it's a little hard to describe an American! Maybe I had better start by saying he is a peaceful fellow, hates to start anything that he thinks will hurt his fellow man. Some folks think he is slow-starting,

well, maybe so, but once he gets started he can produce faster than anyone, especially those who threaten the peace and security of his home or his liberty to go and come or do what he wants to do.

Son, an American is the fightin'est fellow I know of when you threaten him with the loss of any one of the real American principles.

BUY MORE BONDS!    
**hallicrafters**  
 CHICAGO, U. S. A.



# SCR-299

## VANGUARD OF INVASION!

THE SCR-299 Mobile Radio Communications unit played a great part in the invasion of Africa and Sicily . . . these units were used as mobile radio stations, transmitting voice commands to fast moving armored units while in action, or as permanent radio stations . . . even under the most difficult operating conditions. A leading military authority said, "My observations in the theatres of war make it possible to say that the SCR-299 hit the jack pot in the mobile radio field as has the jeep in transportation."



**the hallicrafters co.**  
CHICAGO, U. S. A.

THE WORLD'S LARGEST EXCLUSIVE MANUFACTURER OF SHORT WAVE RADIO COMMUNICATIONS EQUIPMENT

---

---

# RADIO-CRAFT

with

POPULAR ELECTRONICS

---

---

"RADIO'S GREATEST MAGAZINE"

. . . . Don't expect to buy  
your ultra-modern radio re-  
ceiver the week after peace  
has been declared . . . .

## NEW RADIO INVENTIONS IN THE POST-WAR WORLD

By the Editor — HUGO GERNSBACH

**F**OR the past several months we have been treated to a unique spectacle in radio history—to sit in on a preview of some new radio inventions which will come into being after the war.

While everyone in the field must admit that there will be many revolutionary changes and marvelous radio applications after the war, the catch is that the term "after the war" is, and will remain, exceedingly flexible.

Supposing that by extraordinary good luck the war should be over by the end of 1946; will all the impatient radio customers have their new-fangled radio sets in January, 1947? The answer is a categorical "NO."

The reasons for this are manifold, as will be seen from the following short resumé, which by no means gives all the reasons.

If we look back through radio history, as well as the history of any number of inventions—whether they be the automobile, flying machine or telephone—it will be seen that no new invention has ever made its appearance overnight on the commercial market. Thus, for instance, we had radio broadcasting as early as 1908, when Dr. Lee de Forest was broadcasting phonograph records, the same as we do today. Yet it took 12 years until KDKA of Pittsburgh went on the air in 1920 and when the country at large finally took to radio in earnest.

It should also not be forgotten that the radio tube was invented by Dr. Lee de Forest in 1907, and there seems no particularly good reason to laymen why the complete radio tube set, as we know it today, should not have been manufactured and sold on a large scale in 1908. Nevertheless, that is exactly what did not happen. No radio sets in large quantities were sold until about 1924. There were many reasons for all of this, too numerous to catalog all of them. A few reasons are given here:

When KDKA went on the air, it took several years to build broadcasting stations which people could listen to in all parts of the country. Although factories worked overtime to fill orders for broadcasting plants, and although high premiums were paid to rush stations to completion, yet there was the usual time lag. The industry simply was not prepared to take care of the many orders they received. There seems also no very good reason, if you look back, why self-contained power operated radio receivers could not have made their appearance in the year 1922-23. Remember, we were using batteries with all radio sets in use in those days. Next we switched to battery eliminators, which had their vogue for a year or two, and then several years later the modern radio set, as we know it today, and which you plug into your light socket, was offered to the public. The reason here was that it took years to evolve the necessary radio tubes and other instrumentalities necessary for the operation of a modern radio receiver.

It will be exactly these things that will hold up most of the fabled radio sets which will make their appearance "after the war."

To begin with, all radio manufacturers, without exception, are

now working on war orders. It is also quite true that many of the far-sighted ones have already made plans for the post-war radio set. Many of such ultra-modern radio sets are already out of the blueprint stage and samples and models have been built. That does not, however, mean that the manufacturers can start delivering sets the week after the war is ended. They first must change their entire production from a war basis to a peace basis. They have to retool, make new molds and new jigs, while new machinery must be built to switch over from the war to the peace effort. *All this takes time.*

Then there arises the problem of patents on a number of new radio inventions which already have been made. It is known that there have been made so far a number of important, if not revolutionary, radio inventions. More of them will be made before the end of the war. Many of these inventions will make the ultra modern radio set, of which I spoke—and which already may be out of the blueprint stage—completely obsolete by the time peace is declared. These are not insurmountable obstacles, by any means, and I do not wish to leave the impression that it will take five or ten years after the war is over until the ultra-modern radio set will make its appearance in quantities. Nevertheless, it certainly will take several years, even under the best and most favorable circumstances.

Even if the radio manufacturer's all did get together—which they have never done in the past—and pool all the important new inventions, there still will be a necessary technical delay of at least one year or more for the following simple considerations.

It is conceded today by practically all authorities that the present radio broadcast channels are already obsolete. Very soon, at the close of the war, there will spring into being thousands of frequency modulation stations. The Federal Communications Commission already has hundreds of applications for such stations which cannot be built for lack of materials. Therefore, these stations with all of their broadcasting equipment must be completed first. That means a terrific amount of equipment which is certainly going to choke many branches of the radio industry for some time. It is also conceded that the country will want television some time after the war, and that most of the radio receivers that will be sold must work on 6 meters or below—and on frequency modulation bands. But again, television—as I mentioned in my editorial in the July, 1943, issue, is not ready. There is still a good deal of work to be performed before the television receiver can be put into mass production.

All in all, it will be seen from the above that it will take from one to three years after peace has been declared until the ultra-modern receiver can be bought at a radio store.

This does not mean that there will not be certain "stop-gap" radio receivers sold in the interim period. The same may be said of the automobile, because the car which you will buy at the end of the war will probably be a 1942 model in many respects, until the automobile industry, too, has switched over from a war to a peace production.

## A Digest of News Events of Interest to the Radio Craftsman

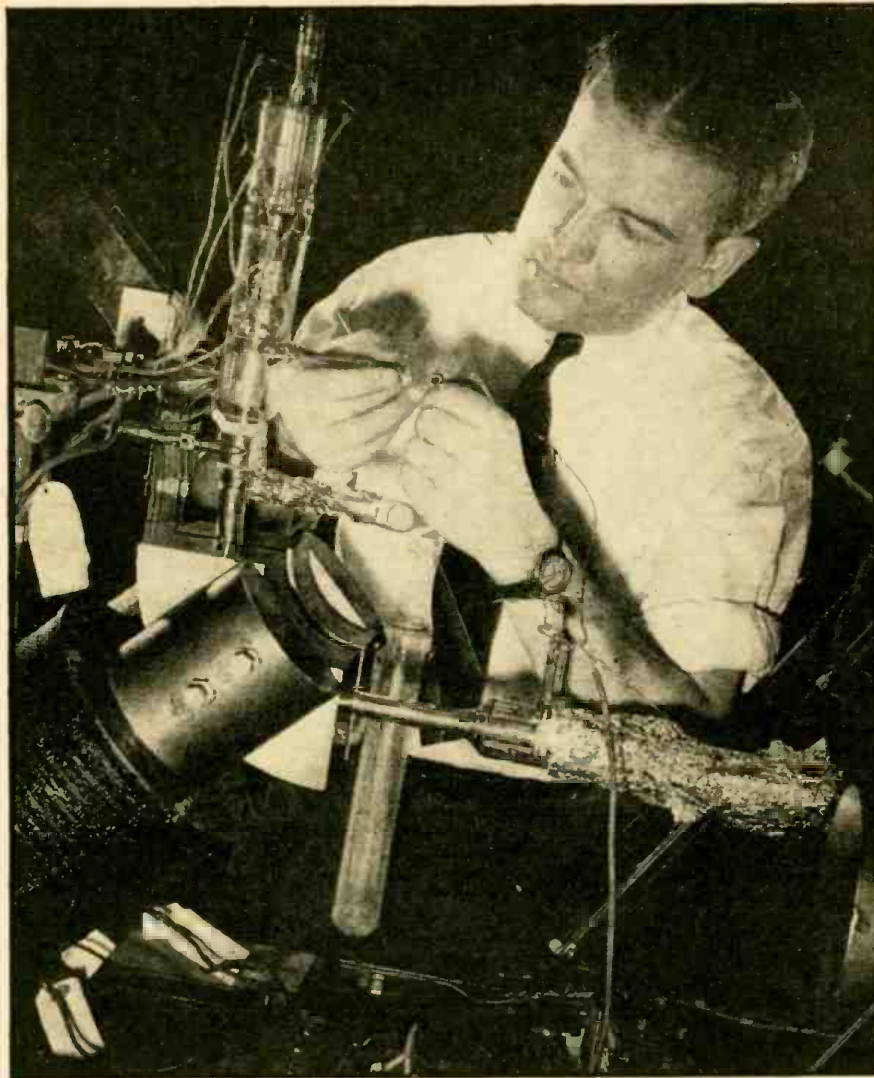

### ELECTRONIC ANALYST SPEEDS WAR CHEMISTRY

**A** NEW electronic device, the mass spectrometer, faster and more accurate than a dozen top-notch chemists, is ready to do its part in winning the war by greatly accelerating wartime chemical research, according to a statement released last month by Westinghouse. It is a valuable laboratory tool for scientists seeking more powerful gaslines, new plastics and improved synthetic rubber. An average college student can be taught to operate the spectrometer in a few weeks.

Developed by 32-year-old Dr. John A. Hipple, physicist at the Westinghouse Research Laboratories, the electronic "chemist" swiftly and precisely analyzes many of the complicated gases formed in making butadiene, the principal ingredient of several types of synthetic rubber. In 15 minutes this spectrometer will dissect a complicated gas molecule a twenty-five-millionth of an inch long and can be adjusted to automatically produce an autograph that tells the chemist the composition of the gas.

At present, certain analyses require from 15 hours to three days of painstaking labora-

tory work by five to ten skilled chemists. Others cannot be done at all. Results attained by these tedious methods are much less accurate than the molecular "portrait" that comes out of the spectrometer.

Butadiene molecules, Dr. Hipple explained, are carefully built up from carbon and hydrogen atoms according to definite chemical patterns, much as a tile-setter selects colored blocks to form a design on a floor. As the molecule is being put together in a butadiene plant, its composition must be checked at intervals to make certain that the chemical pattern is being followed.

Present methods of determining the molecular structure are so slow that a batch of butadiene has often gone through the various treatments of the process before the analysis is completed. If there is an error in the molecular design, the butadiene will make a poor quality synthetic rubber. Sometimes a batch of butadiene has to be re-processed, causing lost production time.

The spectrometer is housed in a cube-shaped cabinet five feet high. Its key part is a yard-long glass vacuum tube shaped into

a quarter-circle. This tube, lined with metal, is fixed between the poles of an electromagnet.

Molecules of the gas being analyzed are given an electrical charge at one end of the tube and are shot toward the other end at a speed of approximately a million feet a second by high voltage electricity. The electromagnet pulls at these speeding molecules so that only those having a certain mass, or weight, travel down the center of the tube, around the bend and through a tiny slit in a metal target at the other end.

The molecules going through the target are collected on a metal plate where they give up their charges. Then the charges are amplified and counted by electric meters that indicate how many molecules of a certain weight are in the mixture.

Molecules weighing less than those hitting the target are pulled to the metal lining of the tube before they can get around the bend. Heavier ones offer more resistance to the electromagnet's pull and strike the other wall of the tube as they try to negotiate the bend.

The mass spectrometer requires only a thimbleful of gas for each test. Butadiene plant chemists now have to draw off a bucketful of gas for the involved laboratory procedure of breaking down the mixture by "fractionating" or distilling.

### POST-WAR TELEVISION

**T**ELEVISION is going places after the war, but, judging from statements made last month by Ralph R. Beal, research director of RCA, and E. F. McDonald of "crystal-gazer" fame, it is by no means clear just where it is going to go.

Mr. Beal says that full-scale television will become a fact "within the shortest space of time required to reconvert the radio manufacturing industry from war to peace production."

The president of Zenith, on the other hand, insists that television for all is not half so near as the public has been led to believe.

"Television is technically ready, but it is economically unsound because no means for financing the programs has been discovered," insists Mr. McDonald. "There is nothing wrong with television that money won't cure—but there won't be programs feeding into homes until a 'box office' for the producers is found."

Television receivers should not be sold to homes on the argument that television will spring into common use overnight when the war ends, McDonald maintained.

"Premature and exaggerated publicity about television is misleading the public now just as it did four years ago," he declared. "Television won't become a great industry until the economic riddle of how it is to be supported is solved."

The cost of receivers to the consumer was another point seen as holding up the rapid spread of television. Before the war, a television set cost nearly \$400. Mr. Beal warned against taking this as a probable post-war figure. Wartime discoveries, he said, have acted as a catalyst to speed up television research, and new methods and materials will have their effect. Post-war labor and material costs, now unpredictable, will also be a factor in the price of receiving sets, making a close guess as to their cost impossible. (See also the July *Radio-Craft* Editorial on this subject.)

Wartime research, according to the RCA executive, has greatly advanced television technique, and has made possible a set with a vision screen two feet square, and at a price within the means of the average family.



## ELECTRONIC SPAGHETTI?

**R**ADIOMEN have long been familiar with the use of spaghetti (varnished cambric tubing) in the insulation of radio wiring, and more than one remembers when every wire in the set—however far isolated from others—had to have its overcoat. The Westinghouse announcement last month that spaghetti was being used in the construction of vacuum tubes therefore caused no surprise.

No surprise until the radioman discovered that it was real spaghetti—the edible variety—that was being used! It is inserted inside the coiled filament of vacuum tubes as a support for the wiring, with the great advantage that the spaghetti can be easily burned out after the filament wires are welded in place.

The former practice was to use steel supports, and much time was wasted removing them.

The photograph shows a worker making connections to the slender filament wires. The spaghetti inside the filament coil may readily be seen.

"A stick of spaghetti placed inside a tiny wire coil supports the coil while it is being welded," explained D. D. Knowles, manager of electronics engineering. "A piece of steel formerly was used as the support but it was difficult to remove. Spaghetti can be burned out in a flash.

"Because of the important savings in time, man-power and materials, we are recommending Mr. Hayes for a WPB Award of Individual Production Merit. His method enables us to produce 50 per cent more filaments and at the same time allows assembly operators to spend part of their time on other production jobs."

Wire filaments for many tubes, the engineers pointed out, are coiled in the shape of a small spring three-quarters of an inch long. When each coil was being welded to the rest of the tube mechanism, a steel piece about as thick as a seven penny nail was inserted inside the spring coil to support it and keep it in accurate alignment.

"This steel 'nail' had to be split with a saw before inserting it in the coil," Mr. Hayes explained. "Without the split, the nail was difficult to remove after the welding job because the coil tended to tighten around it. Sometimes removing the steel piece jarred the coil and it had to be re-aligned. The whole job was troublesome and time-consuming, and I was assigned the task of breaking the bottleneck.

"After trying about everything else. I got down to spaghetti. We now insert a little stick of spaghetti where the steel piece used to go. After the filament is welded, electric current is passed through the coil to remove any impurities in the metal and this

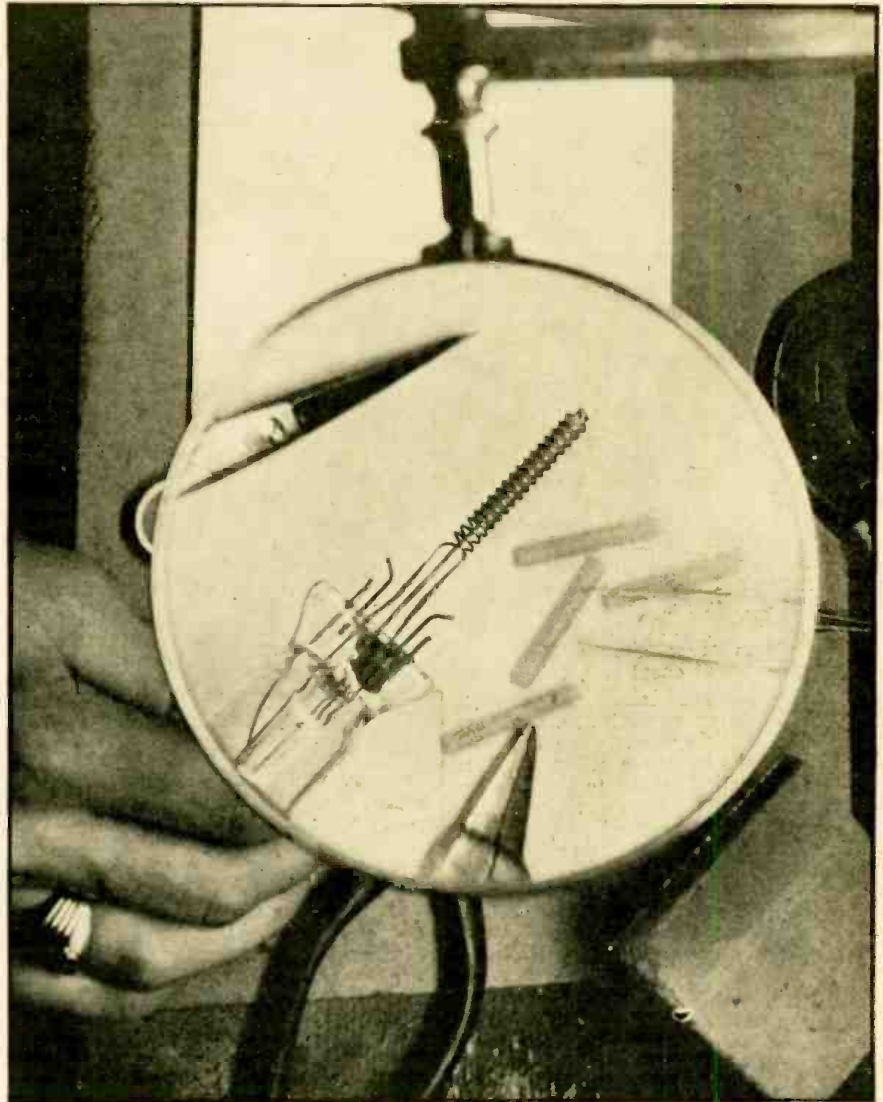

burns up the spaghetti in a flash. No spaghetti, no removal problem."

This assembly operation formerly required about five minutes to complete for each tube filament, the engineer pointed out. By using spaghetti instead of steel, the job now can be handled in a quarter of that time.

Mr. Hayes explained that his idea didn't take final shape all at once:

"I thought of spaghetti but decided to visit a manufacturer and find out how ac-

curately it can be produced with regard to exact size. I found that spaghetti can be made with fair precision. It is strong enough not to break if handled carefully and can be machined in a lathe. For our experiments, I put a stick of spaghetti on a lathe and machined it to the correct diameter.

"We have supplied the spaghetti maker with a die to enable him to produce sticks the correct diameter for our tube operation. From now on he is in war production."

### W. D. TERRELL RETIRES

**O**NE of radio's oldest Old-Timers retired from active service last month, when William D. Terrell gave up his post as chief of the FCC's Field Division on August 31st.

He was given the office of "Wireless Ship Inspector" by the Department of Commerce in 1911. His "staff" comprised another inspector, the late R. Y. Cadmus. In 1915, he became "Radio Inspector in Charge", with a force of 35 persons. Later he was put in charge of radio regulation in the old Radio Division and when the Federal Radio Commission was created in 1926, he continued his supervisory activities.

When the FCC took over all communications in 1934, Mr. Terrell was made head of the Field Division.

### RADIONICS—ELECTRONICS

**T**HE *Radionics-Electronics* battle has crossed the Atlantic. Last month's issue of *Electronic Engineering* (London), devoted a short editorial to the subject.

The British attitude is chiefly one of surprised pleasure that *Electronics* is credited to them. "It is the general impression over here," says the editor, "that the word was coined by the McGraw-Hill Co. So we are smarter than we thought!"

Beyond that, no great enthusiasm for the new term is manifested in the article. The coiners are warned to beware of meddling with etymology, as the consequences may be unexpected, and it is suggested that a vigorous campaign might well be launched to change "electrocution" into the more

etymologically correct "electrocussion!"

It is further suggested that the tests suggested by A. P. Herbert, author of "What a Word," be applied. These are: "Ask the new word: Are you intelligible? Are you pleasing? Are you legitimate? Are you needed?"

Judged by these standards, *Electronic Engineering* respectfully suggests, *Radionics* is an also-ran.

The British editor welcomes with pleasure *Radio-Craft's* defense of *Electronics*, and ends his article by quoting Mr. Gernsback's May statement "... In 1924 I coined the humorous word **RADIOTICS** for a radio joke column. Maybe that is the less befuddling term."

# POPULAR ELECTRONICS\*

By RAYMOND F. YATES  
PART VIII—PHOTOCONDUCTIVE CELLS

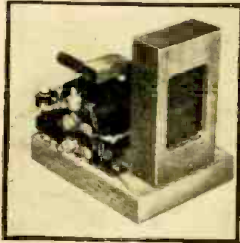

A home-made photo-cell.

**E**VEN with modest materials and a few rudimentary tools, any student of electronics can assemble selenium cells and use them in fascinating experiments that will do far more than words

to teach the fundamentals of the art. Every experiment is an adventure, and the following chapter will be devoted to the experimental employment of both photo-voltaic and photo-conductive cells, such as selenium. A full discussion of the construction of selenium cells is the object of the present chapter.

The reader has been learning something about cells based on photoelectric surfaces enclosed in glass containers. The conduction of these cells under the action of light and anode attraction is due to the release of electrons from the photoelectric surfaces. Such cells are often referred to as photo-emissive cells, while the cell that is about to be considered is called photo-conductive. In the case of selenium, the action of light brings about an internal change in the atomic structure of the selenium that has the effect of lowering its electric resistance. The real nature of the effect is quite unknown, but selenium, it must be remembered, is not photoelectrically responsive in the same way as photoelectric cells of the vacuum or gaseous types. The cells of these types actually generate a minute current, while selenium does nothing of the kind. The resistance of the material is lowered under the action of light; hence more current is allowed to pass. Thus relays can be closed by light control.

The selenium cell has limitations that prevent its being used in connection with experiments where speed is a vital factor. Selenium has a certain time lag, and although this amounts to an insignificant fraction of a second, it is nevertheless great enough to prevent the use of the material in connection with television. For all ordinary purposes, however, cells of this material can be used with a great deal of success. They possess the added advantage of being easy to make at home and of costing very little. They also possess a ruggedness of

construction and of operation that is not to be had with other cells. On the whole, they are ideal photoelectric material for the experimenter to play with.

A large number of these cells may be made in the home laboratory for the cost of a single photoelectric tube of either the vacuum or the gaseous types. Chemically pure selenium costs about \$1.50 per pound, but it must be kept in mind that a comparatively large number of cells may be made with a single ounce of the material.

The life of a selenium cell will depend upon how carefully and how intelligently it is prepared. It must be confessed it will also depend upon some unknown factor that makes the efficiency of any cell, no matter how carefully prepared, a mere matter of conjecture. Most cells will last over a period of months and some will last for

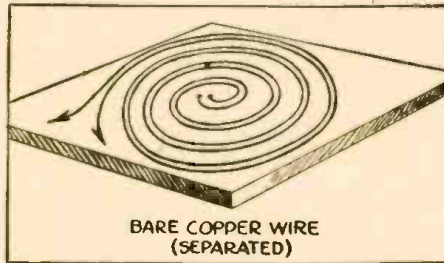

Fig. 1 (B).—Some experimenters prefer this form of winding for a photo-conductive cell.

years without having their sensitivity drop more than 30 per cent. Even though conditions of production are under perfect control and a group of cells are put through together under precisely the same conditions, these cells will not run uniform.

Selenium cells are formed by applying a thin layer of molten selenium over two electrode surfaces, these surfaces being as close together as possible. One of the early cells designed for ordinary use and still preferred by many amateurs was made by simply winding two small and clean copper wires side by side on a mica plate approximately an inch and one-half long and one inch wide. It may be made even smaller than that. The trick of winding a piece of heavy thread on the mica slab with the two copper wires is resorted to, thus keeping the wires spaced the required distance apart. Once the wire and the thread are in place, being wound as tight as possible, the thread is removed so that the molten selenium will flow down into the spaces between the separated wires. Some amateurs wind their cells on mica forms that have had their edges notched saw-tooth fashion, so that the wires will be sure to remain in place.

The type of cell just described is known (after its designer) as the Bidwell cell. Another popular form has become known as the Townsend cell. In this type two sets of brass washers are placed or mounted upon a spindle with the proper insulation sandwiched in between. The selenium is then smeared over the exposed edges of the brass washers.

The principle of still another type of cell, the Mercadier type, is very similar to the

Townsend, save that brass strips are used in place of brass washers. The two strips are separated with some sort of insulation and then wound into the form of a spiral

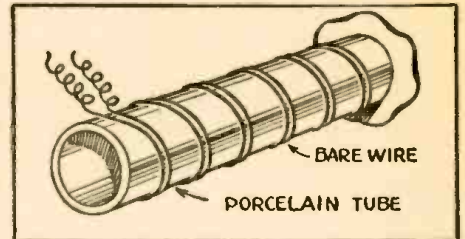

Fig. 1 (C).—A variant of the Bidwell cell, wound on an ordinary porcelain wall-insulator tube.

and held in place with two wooden clamps.

In all the various cells mentioned, electrical connections are established through binding-posts that are connected to the two sets of copper wires or the two sets of washers or strips. When the selenium is placed in the dark, the resistance between the electrodes is great enough to cut the passage of any ordinary voltage almost to zero. A comparatively large amount of current is permitted to pass if the cell is exposed to light. Hence, when cells are left connected to their electrical circuits, it is advisable to arrange them in light-tight compartments equipped with removable covers. This will prevent the flow of any serious amount of current and will also add greatly to the life of the cell, which, if left constantly exposed to light, would eventually become fatigued and useless.

Selenium is related on the periodic table both to sulphur and to tellurium, and at present our national supply comes from



A close-up of the 210 photo-cell circuit with shield off.

\*Application for Trade Mark Title, pending in U. S. Patent Office.

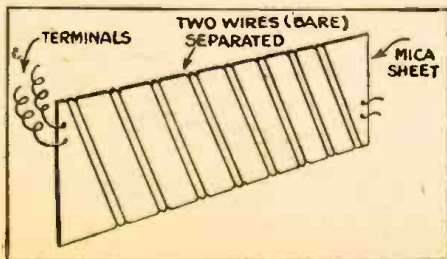

Fig. 1 (A).—The Bidwell selenium photo-cell cell, as wound with copper wire on a small notched mica strip.

working over the muds of our electrolytic refineries.

Something has been said heretofore about melting the selenium in the construction of

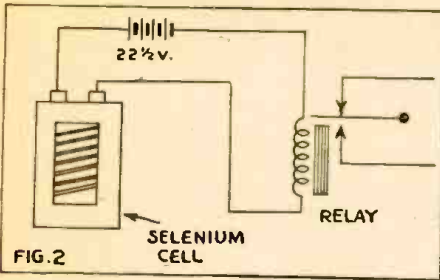

photo-sensitive cells. Really, the matter is not quite as simple as that. Not only must the selenium be melted (it acts very much like sealing-wax when exposed to a sufficient degree of heat), but the resulting cell must thereafter be annealed. WHAT IS MORE, THE FUMES ARISING FROM MOLTEN SELENIUM ARE HIGHLY POISONOUS, AND THIS WORK SHOULD BE CARRIED ON EITHER OUT-OF-DOORS OR NEAR AN OPEN WINDOW.

Although a number of types of cell grid (that is the cell before the selenium has been deposited) have been proposed, the beginner will do well to choose one of the types illustrated in Fig. 1. The Bidwell cell should by all means have as its foundation mica or an equally good insulator capable of enduring not only the heat applied in the melting of the selenium but also the long session of annealing which is carried on at elevated temperatures.

The selenium employed should be of the chemically pure (C.P.) variety, and here let it be said that selenium merely melted and spread over a grid will not function photo-electrically. In such a state the selenium is amorphous, and for reasons still not clearly understood, the selenium must be reduced to a crystalline state before it exhibits the property of photoelectric conduction. Selenium is an insulator in the dark and a partial conductor when exposed to light. For this reason, it must always be used with a battery. It is not a case of generating current as in the case of the ordinary photo-cell but rather of permitting current to pass in small amounts due to a great reduction in electrical resistance.

A clean gas flame such as that of a Bunsen burner is best suited not only to the melting of the selenium but to the annealing as well. A holder will also be helpful.

After the grid has been prepared, it is arranged over the Bunsen flame in such a way as to avoid direct contact and too sudden an application of heat. Indeed, as selenium melts at a point somewhere in the neighborhood of boiling water, there is little advantage and only a chance of possible damage to the grid in permitting the temperature to go much beyond this. A chemical thermometer will help a great deal. Another reason that the temperature rise of the grid should be gradual is to prevent the warping of the grid if the type shown at B in Fig. 1 is employed. Sudden heating of the type shown at C will endanger the porcelain insulator and might result in cracking.

Of the three types of cells shown, perhaps the Bidwell (A) cells offer the best possibilities for the amateur or beginner. The materials required are easily available and the mechanics of the device are delightfully simple. Inasmuch as it is desirable to have a uniform distance between the copper wires or electrodes, it will be found expedient to wind the wires in place, using a piece of fine string or heavy thread to keep them sep-

arated. The wires should be as close together as possible without actually touching. They should also be wound tightly to prevent their shifting after they have been set in place and before the molten selenium is applied. After the cell has been completed, the hard selenium between the wires will prevent any movement. Just before the molten selenium is set in place, it might be advisable to test the separation of the wires with a buzzer and battery to check for a short circuit. Otherwise, the builder might later wonder why the cell refuses to function.

Returning to the matter of actually applying the selenium, we again point to the necessity of keeping the cell grid at a temperature not exceeding the melting point of the element and also of making sure that the temperature is not raised suddenly.

As the selenium melts upon contact with the hot cell grid (the wires) it is spread thin, with the blade of a jackknife as a spatula. The spreading should be as uniform as possible over the entire grid area. The thinner the surface of the selenium the better. A thin surface of selenium will almost be transparent, certainly translucent. We repeat that the worker should be careful not to inhale any fumes from the molten element. They are extremely dangerous, and it might be advisable to breathe through a moistened handkerchief while this work is being done. The odor of molten selenium is characteristically like radishes—avoid it.

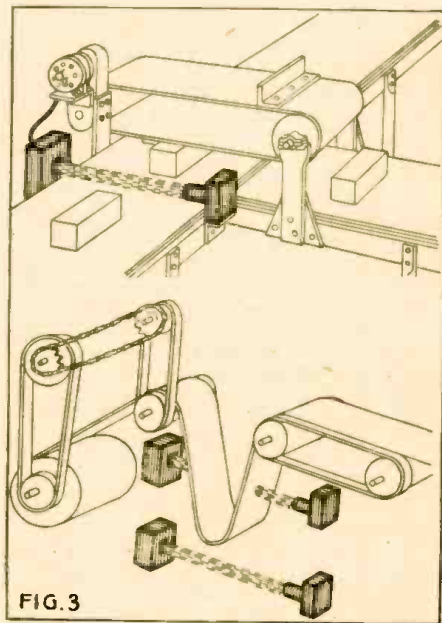

In no case should the worker permit selenium to cool quickly after melting. Such abuse quickly destroys all photo-activity of the element. After the selenium has been carefully put in place, the Bunsen flame should be lowered gradually over a period of an hour or so until a return to normal temperature has been made.

This annealing of the selenium must be accomplished with care. It is not difficult, and perfect results will be had if the simple directions given herewith are carefully followed out. It is not a question of skill but rather one of caution and strict attention to instructions. No liberties should be taken with the following information.

To anneal, first place a large piece of mica (such material may be had at the local hardware store for a few cents a sheet) over the ring of the stand. The selenium-covered cell is placed on this to avoid direct contact with the heat; we deal here with re-radiated heat. The ring is also lifted high, so that only moderate heat will at first come



Using a flashlight for a start-stop switch.

from the Bunsen burner. After a few moments of this to take the chill from the cell, the ring is lowered, an inch or so at a time, until a point is reached where the surface of the deposited selenium turns a dull gray color. Once this condition of color and semi-plasticity is reached, the worker should take care to see that no further increase in temperature takes place. If at any time during the annealing process actual melting is observed, the applied heat should be immediately reduced. A condition must be cautiously approached where the heat will be applied at a point just below melting, and for a period of two and one-half hours. After the lapse of this time, the heat is gradually reduced until normal room temperature is reached. The descent should take about one hour.

Before the worker goes to the trouble of mounting the cell, he should check it electrically or photo-electrically, to make sure that it is sufficiently active to warrant such care. The test is made with the simple electric circuit shown in Fig. 2 with a milliammeter taking the place of the relay. Under such conditions, we should have a current reading of a milliampere or more when a 60-watt lamp is brought near.

No matter how uniform the conditions are kept in the home construction of these wonderful photo-electric devices, uniformity of response is very difficult to achieve. For that reason, the builder of such cells is advised to make several at a time and thereafter to choose by actual test the one that is best.

Once a cell has been selected by test and its response is known to be good, provision should be made to protect it in some sort of glass or wood-and-glass envelope. In the wood-and-glass envelope cigar-box wood

(Continued on page 758)

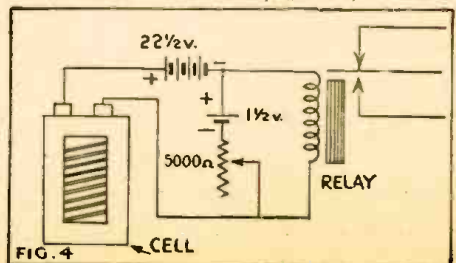

FIG. 4

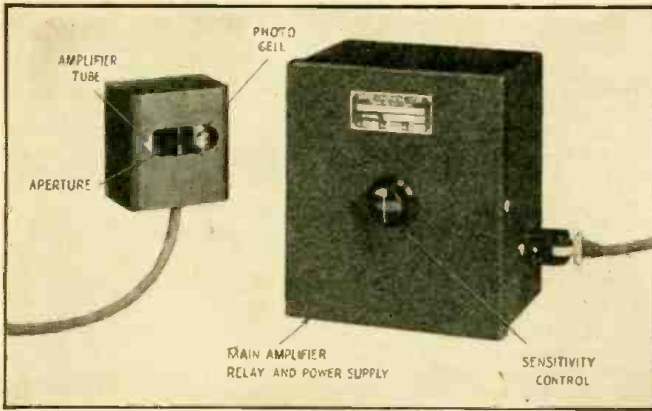

Photo A.—The photo-cell unit with its control box and amplifier.

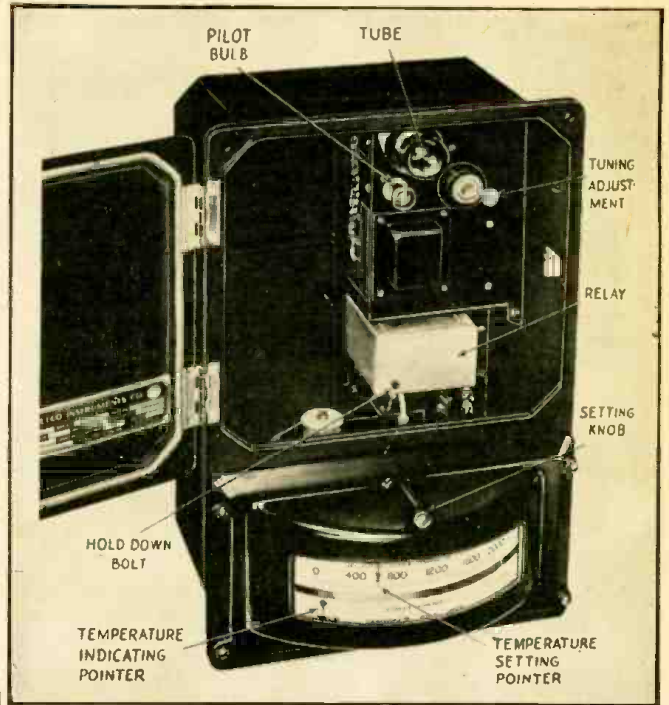

Photo B.—The radio oscillator type of cut-off.

# RADIO SCALE

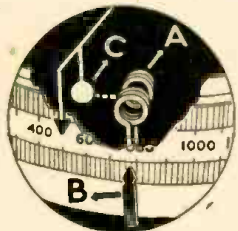

Fig. 3.—The heart of the oscillator cut-off.

**E**LECTRONIC devices in the lighter forms of industry have become so common that no one is surprised at their invasion of the grocery store, as in the Electronic Coffee Roaster described a short

time ago. A further application which finds its use not only in stores, but in warehouses, factories and all packaging establishments where containers are filled to a certain weight, is the Electronic Scale Control.

The photo-cell, so commonly used for scanning objects to be counted, persons approaching a door to be opened, or intruders entering a forbidden area, can easily be used to note the position of a scale pointer. When it approaches the point on the scale indicating a pre-determined weight, a relay can be actuated and an alarm sounded, or filling devices stopped.

An ingenious adaptation of the photo-cell to this type of work is the United Cinephone Photo-Electric Cut-Off, illustrated in Photo A. This consists of an ingenious small photo-cell housing, and a larger unit which holds the amplifier, relay and power supply. The housing, less than  $3 \times 2\frac{1}{2} \times 1\frac{1}{2}$  inches, contains not only the photo-cell but a lamp to be used as light source, and a one-tube "head amplifier." A parabolic mirror behind the light source projects a beam of light on a narrow path toward the scale plate.

The whole compact assembly is mounted on an arm which can be pivoted to bring the photo-cell and light source before any portion of the dial plate (see Fig. 1), thus operating the relay at any weight to which it may be desired to set the device. In automatic filling operations, the relay when actuated, may be made to put machinery into motion which will stop the filling, move another container into position on the scale, and start again.

The principle of operation is simple. The scale plate is made of a light-diffusing material and the pointer of a bright reflecting metal. Rays from the light source cover a

more or less narrow band in front of the aperture. When the pointer reaches a spot half way between that portion of the scale plate which lies directly ahead of the photo-tube and that portion directly ahead of the aperture, the angles of incidence and reflection are such that a considerable quantity of light is reflected into the photo-cell, and the relay is actuated. (The action is shown in Fig. 2.)

This unit is so constructed that, if necessary, it may be added to a scale already in operation. Even should the scale have a bright plate and a black pointer, it can be made to work by using a relay which makes its contacts on the let-go. Then the relay is held down till the pointer moves into position, when its release makes the local circuit to carry out whatever effect is desired.

A more interesting type of control which works from a moving pointer—such as that of a scale—is the Universal Controller made by Wheelco Instruments. This is something that the radio man will understand and appreciate. In fact, it resembles a radio receiving circuit so closely that one is tempted to insert a pair of headphones and see if there may be a signal floating around in the wiring.

Briefly, the operation is that of an oscillating tuned radio circuit. The two coils "A" of Fig. 3 act as the inductor. A flag "C" is so mounted on the indicating arm that when the pointer passes the scale division to which the coils have been previously set by hand "B," the metal flag passes between the two coils. The circuit is immediately detuned, causing a drop of current in circuits associated with the relay, the solenoid of which is de-energized, thus breaking or making contacts, as desired.

This type of control can be operated with the one tube shown in the photograph (Photo B). It does not require the amplification that is needed in systems using a photo-cell and the current change in its plate circuit can be made large enough to operate the relay directly.

This circuit, like the one using the photo-cell, is an absolutely "contactless" relay, thus avoiding all the difficulties of sticking which crop up in any control device depending on contacts.

The oscillating cut-off circuit is used by

its makers purely as a temperature control at present, though there is no reason why it cannot be applied to almost any instrument using a pointer. Indeed, as may be seen from the article "A Condenser Analyzer," in this issue, it appears that the oscillating

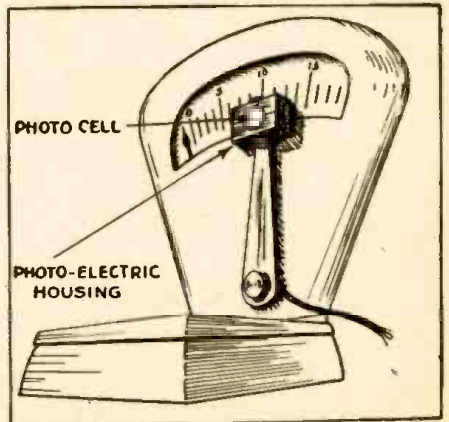

Fig. 1.—How the photo-electric unit is mounted.

circuit may be used in a wide range of controls, measuring devices and relays. Changes in either the capacity or the impedance of a circuit may be used to operate it, and it is capable of an infinite number of gradations in response. Using a meter, it may be made to give a report in detail, instead of

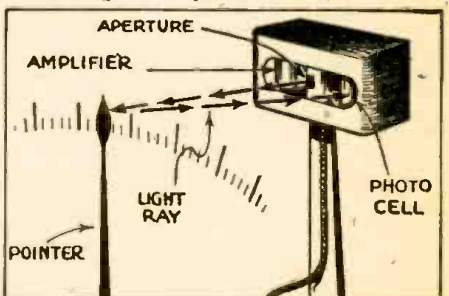
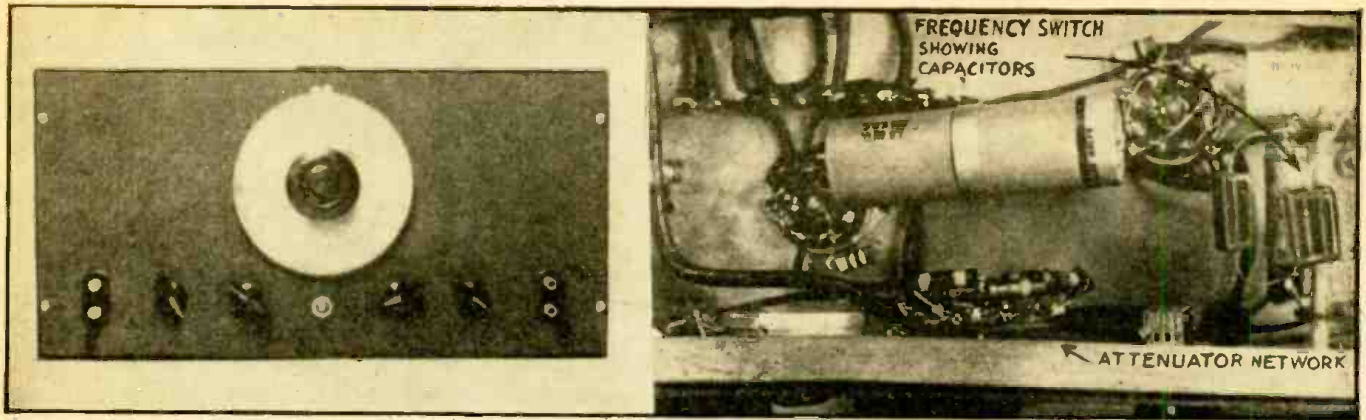

Fig. 2.—Action of the photo-cell scale cut-off.

the black-and-white "off-on" of the relay circuit. There is much room for research in this direction.



Two views of the completed square-wave generator. The important features are pointed out in the underside view.

# SQUARE-WAVE GENERATOR

By WARREN MILLER

THE design details of a simple square-wave generator were given in the February issue of *Radio-Craft*. It was stated at that time that an improved design would be published at a later date. The following article will describe the newer and improved generator.

The earlier model was completely satisfactory for average use. When the device was to be used as a laboratory instrument, it was not quite good enough. Accuracy is the key-note of design for such work, and it was to obtain accuracy that the new instrument was developed. In the earlier model, the reproduced square waves were not absolutely true. A slight difference in time existed between the upper and lower time base. The output circuit—though constantly variable over a range of 2,000 ohms—had no facility for constant output for a given output impedance. The square-wave character tended to drop off toward the upper frequency limit of the instrument. These factors all acted to limit its usefulness for laboratory work.

All these limitations have been overcome in the new model. Thus the instrument has been developed into a true laboratory measuring device. The original model has stood up under a series of tests designed to find its limitations. The output is constant over the entire frequency range—from 6 cycles to 120 kilocycles—for any setting of the attenuator. Variations in the power supply circuit, up to 20% plus or minus, bring about no change from the calibrated frequency.

The calibration was done by hand, a General Radio standard generator being used as the standard. Once calibrated, it should hold to its marked frequencies indefinitely.

The actual circuit used is very little different from the original. The reader who has not seen the explanation of that device should not be alarmed at the apparent lack of anything which would cause feed-back. As stated of the first generator, the high mu of the tube, plus the distributed capacity of the circuit, will cause sufficient oscillation. This point should be noted in selecting a tube for the oscillator. It is advisable, in these times of tube famine, to be able to make a second or third choice if the tube specified is not obtainable. Any high-mu twin triode will probably work well in this circuit, but a low-mu type would not oscillate, unless connected up like a multivibrator, with a small feed-back condenser from the plate of the second to the grid of the first section of the tube. The tubes used were: 7F7 twin triode, 7C7, 7C5 and 7Y4. The selection was based on no

other consideration than that of availability. Whereas other tubes of similar type have been very hard to get, the 7-series are fairly easy to procure. Subject to the caution already given, any of these tubes may be replaced by others the constructor has on hand.

The chief new feature of this generator is the use of a dual potentiometer. One section of it is in the grid circuit. This is used to change the frequency. The other section is in the plate circuit of the first tube. It compensates the differences that occur for the variations of frequency in the time constant, as seen by this plate circuit.

The combined effect is to produce a uniform and true square wave with equal tops and bottoms.

The accuracy, between the two sections of the dual control, must be within 10% over-

all. To get the correct taper with this control, it was necessary to use a No. 6 taper (as shown on the Centralab chart) and operate the control in reverse. This gives an even spread over the frequencies covered.

Another feature is that the rough frequency control covers the range in four steps. The steps are in direct multiples of each other. Step 1 starts at 6 cycles and runs to 120 cycles. Step 2 runs from 60 to 1200 cycles, ten times the fundamental. Step 3 multiplies by 100 and step 4 by 1,000. Frequencies are read on the calibrated frequency dial and the readings are multiplied by the factor indicated on the rough frequency dial, which controls the 4-point rough frequency switch. These readings will be true on all ranges.

It will be evident from the foregoing that a very important consideration is the accuracy of the condensers used in the 4-step frequency multiplier. Condensers (Continued on page 759)

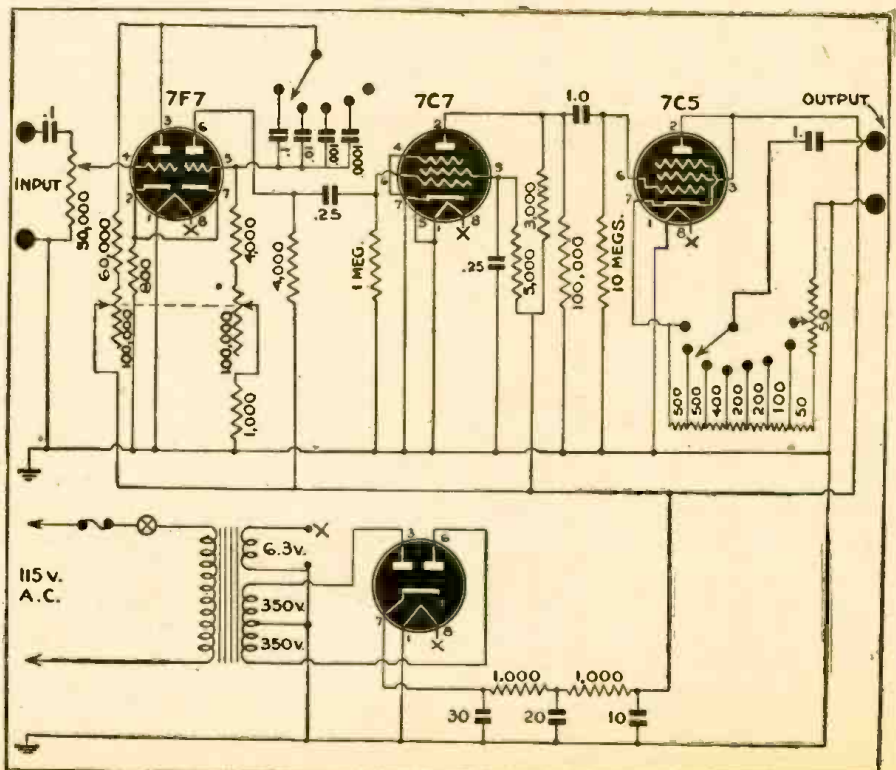

Circuit of the square-wave generator. 7-series tubes are used because of greater availability.

# THYRATRON

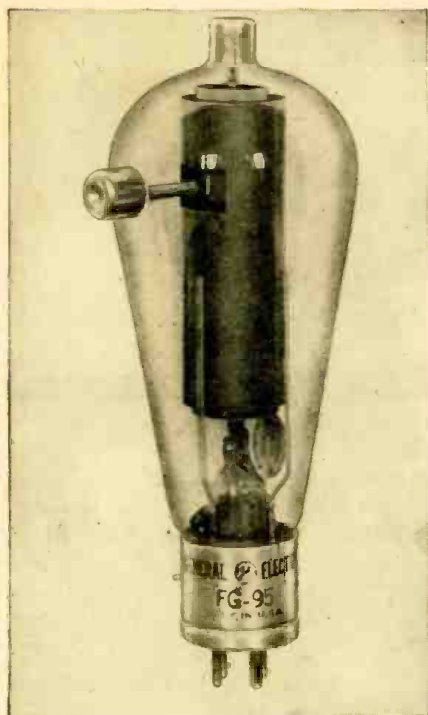

*Second only in importance to the Ignitron among gaseous rectifiers, the Thyatron can do many things impossible to its more powerful colleague, operating control and timing circuits, supplying regulated voltages and currents, changing frequencies, making D.C. out of A.C. and A.C. out of D.C.*

**T**HE Thyatron is a triode rectifier—a rectifier with a grid. There seems little reason for the third element in such a tube—at least to the radioman who is satisfied that diodes are the ultimate in rectification, whether for signal, radio power, or industrial use. Yet the grid makes possible the use of this tube for a host of applications which diode rectifiers cannot handle. Thyratrons are used for supplying steady voltages to loads whose current demands vary widely, for speed control of motors and voltage regulators for generators. The Ignitron welder uses a Thyatron timing control. A small thyatron has long been used as a relaxation oscillator in the sweep circuits of most oscilloscopes, and the tube is also used in stroboscopes. It can be used as an inverter, to obtain alternating current from direct (and if necessary to convert it back to D.C. again), or even to change A.C. from one frequency to another.

The thyatron principle of operation is the same as that of any other triode—with one important difference. The tube consists of a heated filament which acts as a cathode or emitter of electrons; an anode or plate of metal or carbon, operated at a positive voltage with respect to the cathode—in a rectifier circuit, carrying current only when at a positive voltage—and a grid between cathode and anode, to control the electronic

flow. The tube contains mercury vapor or some inert gas.

It is in the action of this grid that the difference between a thyatron and a high-vacuum tube exists. The grid may be set at a negative value so great that for a given plate voltage, no current will flow. (With certain types this "negative" voltage may be zero, or even a few volts positive.) Now, if the grid is made slightly less negative, current will start to flow to the plate. Because of the gas in the tube, ionization takes place, the electrons knocking further electrons from the atoms which compose its "atmosphere", and carrying them along to the anode. The positive charge on the ions attracts more electrons from the cathode, with the result that the internal resistance of the tube is very low. Electrons leaving the cathode are not repelled by a heavy space-charge ahead of them, but are impelled forward by the positive ion cloud. Voltage drop in a tube of this kind is low, as in any gas-rectifier—varying from 10 to 20 volts—and currents are high.

Because of this low internal resistance, currents may easily rise to a value that would destroy the tube. The internal resistance of a high-vacuum tube acts as a partial protective device when load circuits have very low impedances. Connected in similar circuits, thyratrons would simply blow out, as indeed would a diode gas-tube in the same circumstances. It is therefore necessary to be sure that enough external resistance is provided to limit current safe values.

## IONIC SHEATHS AROUND THE GRID

The ions have another effect on the grid. Attracted by it, they gather round and form a thin sheath which completely neutralizes its charge. Any increase in the negative voltage on it will simply result in the attraction of enough additional ions to maintain the neutralization. Thus the area around the grid is always at a potential roughly equal to that of the ion atmosphere at the same relative distance from cathode and plate, and changes in grid voltage have no effect on anode current. The grid can prevent plate current from flowing—it can start the current flow—but it can do nothing about it after it starts.

In this respect, the thyatron is like an ignitron, which can also determine the starting time of current flow, but cannot stop it once it starts. Both these tubes exercise control over the output through determining the point in the cycle at which conduction will start. They differ in the manner of exercising that control. An ignitron is a tube with a normally non-emitting

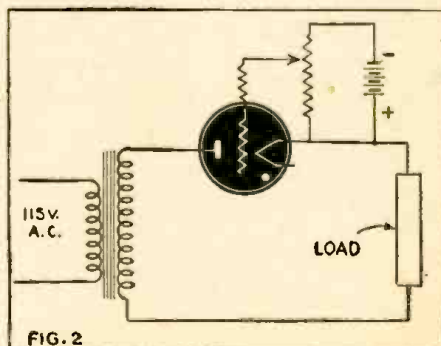

FIG. 2  
Thyatron control circuit. Output voltages may be regulated by adjusting the instant of firing.

cathode, which starts the current at a given instant by causing the cathode to become an emitter. A thyatron has a cathode which is ready to emit electrons at all times, and operates by preventing electrons emitted from reaching the plate until the instant of "firing." After that instant, neither the ignitor or the grid has any more effect until the plate again becomes negative on the next half-cycle, ionization ceases, and the control elements take charge again.

This is the difference between the thyatron and the ordinary radiotron or pliotron. The grid of the latter maintains some control at all times, and an increase or decrease in its voltage affects the anode current. The grid of the thyatron has no effect once plate current starts to flow (with the rare case that in some types an extremely high negative grid voltage may cut off the current if the anode voltage is very low).

## DESIGN OF THYRATRON ELEMENTS

The structure of the thyatron grid differs greatly from the one in a high-vacuum

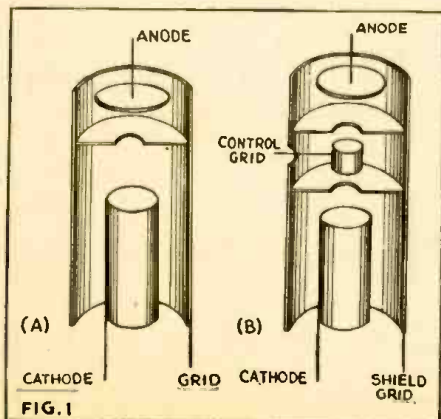
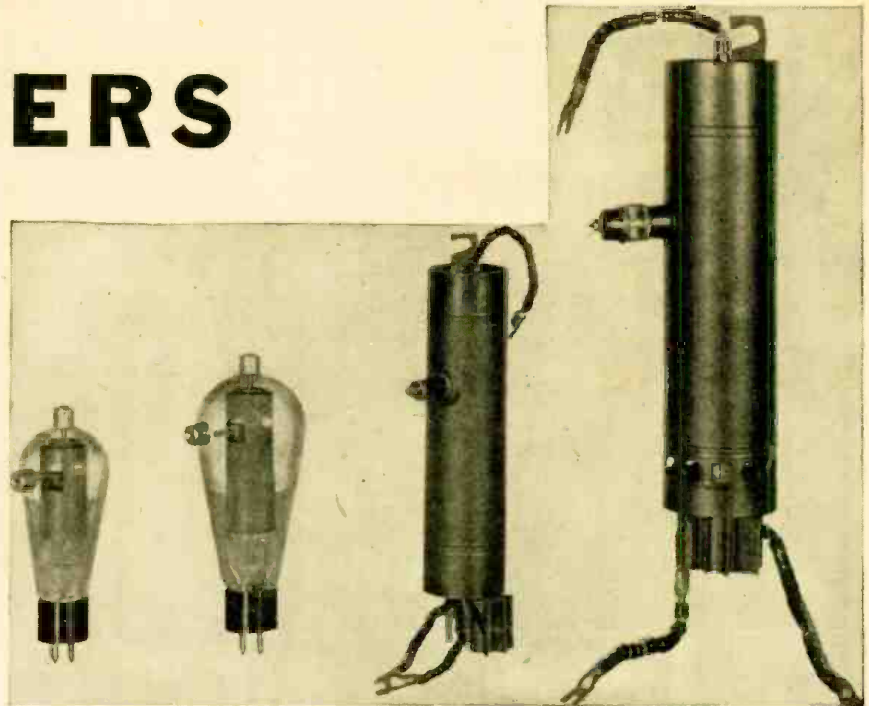

FIG. 1—Relative positions of cathode, grid and plate in thyatron triode and tetrode.

# RECTIFIERS

A group of thyratrons, ranging from one of the smaller sizes up to the largest type. Left to right, they are: G-E thyratrons FG-97, FG-95, FG-172 and GL-414.



tube. Because it must shut out all electrons, and because once a very few find it possible to travel toward the plate, ionization will commence and the grid become ineffective, it is important to assure that no electrons can get past by going around the grid,

the negative grid, and current is in the opposite direction. The very large grid has an extensive collecting surface, however, and in some tubes grid starting currents may be high. This is an important feature, as some control devices are not able to supply the power required by the grid circuit.

of the output voltage.

A more commonly used method of applying control voltage is by some type of phase-shifting circuit which can be designed to cause the grid to pass its critical point at any point in the cycle. Such circuits may use a combination of inductance and capacity, or resistance and capacity, or both, to shift the phase to the desired operating point, and may be made manually or automatically adjustable, so that output voltage can be varied from practically zero to maximum. One such circuit is shown in Fig. 3.

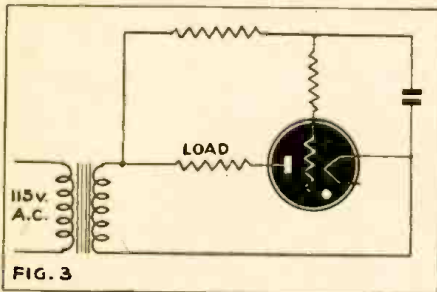

Grid control by phase shifting. The firing instant may be selected by varying condenser and resistor values.

The screen-grid thyatron is the answer to this problem. The structure is shown at Fig. 1 (b). The old grid remains as is, but is connected to a constant source of negative voltage. The control voltage is applied to a small cylinder, or even ring, which surrounds the hole in the screen-grid. Now most of the starting grid-current is carried by the large shield-grid, and because of its small surface, the control grid draws little. Thus the grid-circuit impedance may be relatively high, and the grid may be triggered by low-power devices.

Thyratrons vary from those used in oscilloscope sweep circuits, whose normal current may be 1 milliamperes, to large power types, handling 75 amperes or more.

Where extremely large amounts of power are to be handled, such as in the giant rectifiers used for transportation systems, in steel mills and mines, ignitrons are generally used. Even in such units, thyratrons may be found in the control circuits wherever the output has to be varied to meet special conditions or maintained steady in spite of variable loads.

In view of the range of variations, it is difficult to present the characteristics of a "representative group" of thyratrons, but the data given below gives characteristics of a number of different types:

(Continued on page 759)

Therefore the grid in a thyatron is usually made solid, and designed to shield both cathode and anode completely, with only one or a number of holes to permit electron flow. A common type of thyatron grid is shown in Fig. 1 (a). In form it resembles the cylindrical plate of a radiotron, rather than anything we are accustomed to calling a grid. This cylinder surrounds anode and cathode, and is closed between them by a partition with a single hole in the center, through which all the electrons pass when the tube is conducting. Another type of grid surrounds the cathode, and is perforated with a number of holes in a pepper-shaker effect. The first type is generally associated with tubes which require a negative voltage to keep the tube from conducting—the second with types which fire when the grid is a few volts positive.

## THE SCREEN-GRID THYRATRON

Another grid peculiarity in the thyatron—partly due to its large surface and partly to the gas-filled tube—is the grid conduction phenomenon. The action of a radiotron grid in collecting electrons as it approaches zero bias is well known. Even though it may not be actually positive, a few electrons are carried to it by momentum and set up a very small grid current. In the thyatron, it is the positive ions which are attracted by

## SOME GRID CONTROL CIRCUITS

The methods used in triggering vary according to the application. Voltage may be obtained from the alternating current circuit, from some direct current source such as a rectifier, or from both, in combination. Should it be desired to have the tube fire at some fixed point in the cycle, a circuit like that of Fig. 2 is effective.

The variable resistor permits manual regulation of the instant of firing and therefore

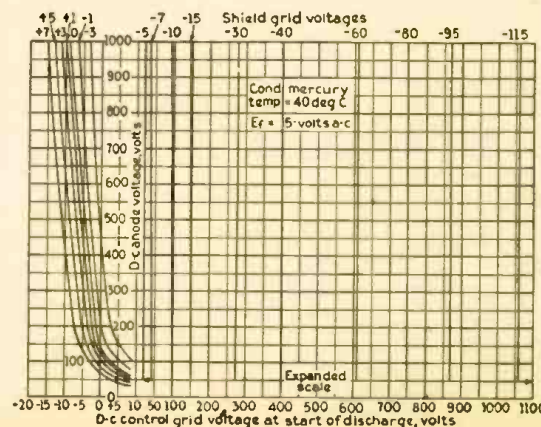

Typical Values of Control-grid Voltage versus Anode Voltage at Start of Discharge.

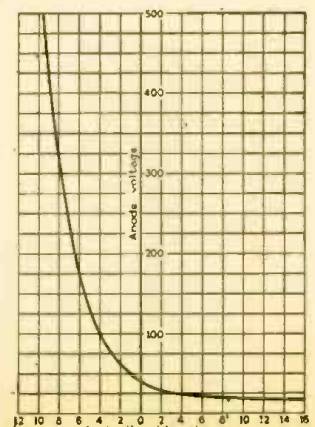



Above.—WAVE operating a Link Trainer (background) and giving instructions to Navy Pilot shut up inside the artificial airplane. Upper left.—Radiophoning the "cleared to land" to an Incoming aviator at Floyd Bennett Field. Middle.—WAVE radio operators handling vital communications at the airfield radio station. Bottom.—WAVES in the control tower at Floyd Bennett Field. The WAVE in the foreground is directing the pilot while her "shipmate" is keeping the incoming plane under observation.

(All illustrations official U.S. Navy Photos)



# WAVES

**W**OMAN has long played an important rôle in times of war—and not always a passive one. The poet of old who sang:

"Oh Woman! In our hours of ease,  
Uncertain, coy and hard to please;  
When pain and anguish wring the brow,  
A ministering angel thou!"

was referring to his heroine's deeds of mercy on the field of battle. Less gentle maidens have left records of valor in our own revolution; and have led armies in various countries from Sweden to China. This is the first war in which the participation of women may be said to be decisive. Early in the struggle they were already manning the ground stations of Britain's anti-aircraft defenses. Women observed the arrival of enemy aircraft and dispatched the fighters who went out to meet them. Women were placed in all positions where a man could be released thereby to go on combat duty. Women even began to be seen in the blue uniform of the Royal Navy.

The United States followed suit, when on July 30, 1942, President Roosevelt signed a bill authorizing the establishment of the WAVES. At that time the idea of women in Naval offices seemed strange enough to some members of the Naval establishment. "Those days are gone forever!" Though to the general public the WAVE is simply a young woman in a chic uniform, whose duties are unknown, the Navy has accepted them completely and without reserve. Possibly the reason is that in many cases their work was found better than that of the men whom they freed for sea duty.

The WAVES on this page are from the important Third Naval District, which includes New York City. The Naval Air Station at Floyd Bennett Field, near the city, leads the country in WAVES personnel. More than 130 young women are on duty at that station.

Not only do the new "seamen" operate the control towers, log flights, work out weather charts and do the detail work of the Naval air stations, but WAVES with ratings of aviation metalsmiths, parachute operators, Link Trainer operators, and aviation machinist's mates also have their places on the staffs of the scattered Naval air stations which guard the sea coasts of the United States.

The WAVES' work is not confined to mechanical duties, either. Many of them are expert aerographers (Naval lingo for "Weather Women"). In the non-aviation branches of the Navy as well as in the air service, one of the chief occupations for which the seawomen are training is that of "radioman". Others are preparing for a wide variety of jobs, including gunnery instructors, censors and pharmacists. Those who already have special qualifications usually find work employing their own particular skills.

The Radiomen WAVES get their training at the good ship "U.S.S. HUNTER", known to landlubbers as Hunter College, The Bronx. More than 3,000 seamen in training are in

(Continued on page 763)



# TALKIE FOR NAVY DIVERS

By BOB CARMAN

**M**ILWAUKEE radio-communications technicians have used their spare time during the last months to design and construct a portable, practical communications system for divers. This is something the United States Navy has been wanting for some time.

Twenty-seven units have been built by the group and have been accepted by the Navy. Much of the designing and modeling was done by Daniel W. Gellerup, Technical Supervisor of Radio for The Milwaukee Journal. The group are part of the staff of WTMJ/W55M. Gellerup served in the Navy during World War I.

Most of the time spent on the work was in the evenings after the men had completed their duties at the station. Their laboratory was the small but complete basement workshop of Herman Lasche, one of the station technicians.

According to Gellerup, the Navy's problem was to get a small, portable system that could be rushed to the scene of a disaster and used immediately. They already had some big 110 volt units operating on alternating or direct current aboard their rescue and repair boats, but wanted something more maneuverable.

Jack Browne, head of the Diving and Salvage Company of Milwaukee was asked by the Navy's diving school to see what he could do. Browne called in Gellerup, who went to work on the problem immediately.

It was no easy task. The Navy wanted something simple that wouldn't have to hang around the diver's neck. Gellerup and his several associates finally came up with an adaptation of various types in use, together with some new ideas.

Previous tests had been made of several practice units in the pressure tank at Marquette University in Milwaukee. A sample was then sent to Washington where the Navy suggested some changes. These were made and the Navy contract for 27 units followed immediately.

Approximately 40 hours of labor went into each outfit, according to Gellerup, and that did not include work done by various sub-contractors on certain parts. Even with a "double-A" priority rating it was very difficult to get some parts. In one case the set had to be re-designed because a tube called for in the original plans was unavailable. The same thing came up with various other parts.

The diver's talkie system is a compact looking affair weighing about 25 pounds and operating on six volt storage batteries. One speaker is in the diver's helmet and another is in the amplifier above the surface. Both speakers are also used as microphones.

The diving amplifier equipment is designed to provide for two-way communication between a diver's tender station on the surface, and one or two divers. Speech pick-up and reproduction in all cases are obtained on the reproducers, these units being used both in their normal capacity and as microphones. The system is normally set up for transmission of speech from all connected divers to the tender. Switching facilities are provided on the control panel to select and talk to any one diver from the surface station. Volume control is also provided to make the speech more intelligible, as picked up under varying pressure conditions.

The amplifier is housed in a heavy formed steel case plated and painted to resist corrosion. On the front of the case is located

the control panel on which are the manual controls. The amplifier itself is mounted on a chassis of special design which is fastened to the bakelite control panel. This panel, in turn, is secured to the cabinet, making the whole assembly splash-proof.

Connection to the two divers' cables is made through two receptacles along the bottom of the rear of the amplifier cabinet. These receptacles are of special design to accommodate the standard Navy Diving Equipment plug. The plugs are so polarized as to prevent the insertion of any plug in the wrong receptacle. Caps for all receptacles are provided for their protection when not in use.

The tender's speaker unit is of the direct radiator type. This is mounted in the front panel. A protective screen is provided for the front of the reproducer to protect it from mechanical damage.

The divers' reproducers, which mount in the diving helmets, consist of small permanent magnet units with a suitable mounting bracket and protective grille. These speakers have an impregnated fibre cone.

The amplifier is a resistance-capacitance coupled circuit using one type 6J7 vacuum tube as voltage amplifier. The second stage is coupled to one 6F6 in the output. Suitable input and output transformers are provided so that the speaker can be used as such, or coupled to the first grid as microphone.

## VIBRATOR POWER SUPPLY

The power supply from which the amplifier is designed to operate is a 6 volt D.C. source. A vibrator type of voltage converter is used to secure the necessary plate volt-

age. This converter is supplied as a unit mounted on the chassis. Incorporated in the unit is a self-driven vibrator, one OZ4 or 6X5 rectifier, a transformer, and the necessary filter chokes and condensers to remove the high transient voltages developed by the rapid switching of the battery current by the vibrator.

Heater operation is obtained by connecting the tubes in a parallel circuit. The power supply is fused and is controlled on the amplifier control panel by means of an "ON-OFF" power switch.

Manually adjusted controls for this system are located on the control panel. These consist of one volume control, two switches for controlling the direction of transmission, and the power switch. The volume control is provided to obtain the correct level at either the tender's or the diver's reproducers. The two two-position switches, one for each diver, provide means for transferring the divers' reproducers from input to output and the tender's reproducer from output to input. These switches are so connected that the normal, or unoperated, position provides speech transmission from all connected divers to the tender's reproducer.

To put the diver communication system into operation, the switch is turned to the "ON" position, and thirty seconds allowed for heating the tubes to proper operating temperature.

As communication is established, the volume controls should be adjusted so that a condition of maximum intelligibility is secured. In general, it was found that this condition existed with the controls set for as low an output level as could be heard over the surrounding noise. Experience in operating these sets also demonstrated that "naturalness" of any particular voice is not necessarily the condition for maximum intelligibility.

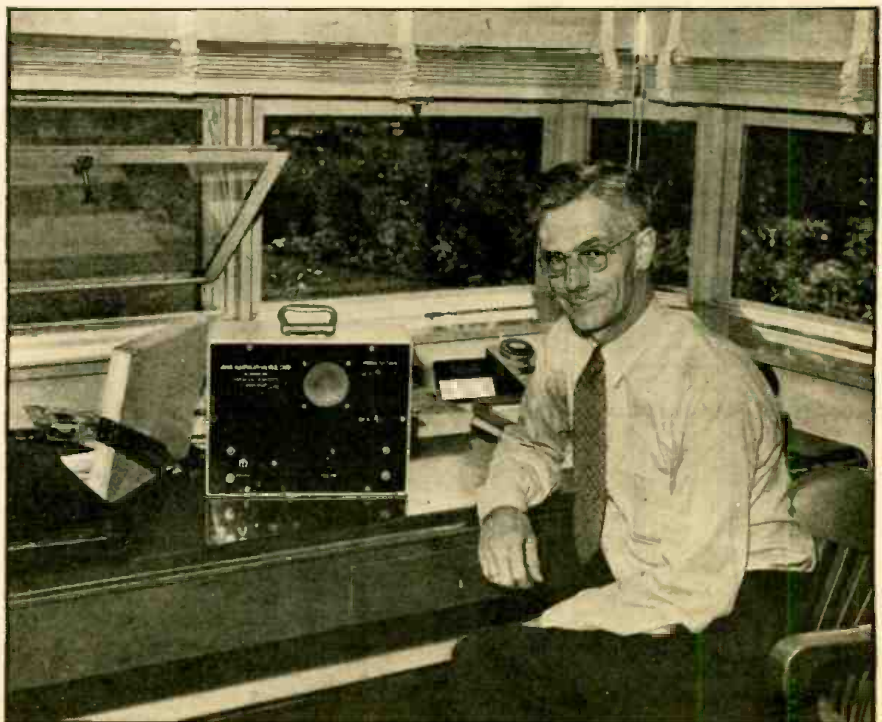

Mr. Gellerup and his under-water intercommunicator, construction details on which have not yet been released by the Navy.

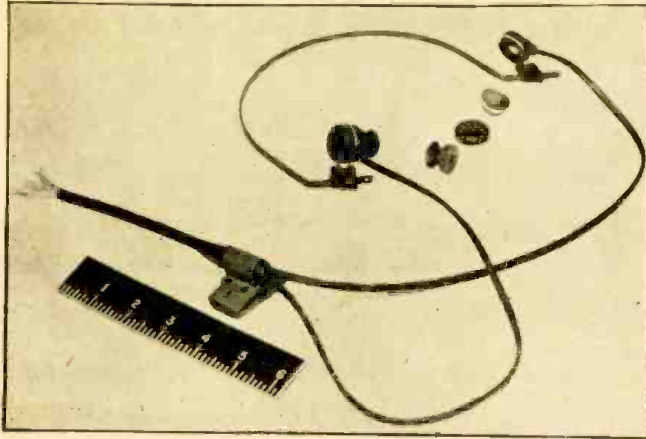

*"Genius," said one commentator, "consists in an infinite capacity for taking pains." It is not only through startling and complex inventions like bomb-sights and radiolocators that the war will be won. Such small but important devices as the headset at the left have an important place. Attention to such details raises the efficiency of an army in dozens of little ways, with crushing cumulative effect.*

## SIGNAL CORPS HEADSET

**"A**LL those fine young men wearing hearing aids!" said the Old Lady from Dubuque visiting a Signal Corps Class for radio operators. "The manpower shortage must really be acute if the Army has to take men who are hard of hearing."

But the Old Lady from Dubuque was wrong. Those "hearing aids" are new headphones which are a direct outgrowth of the new American helmet that protects the sides of the soldier's head and the back of his neck from bullets, and shell and bomb splinters.

In World War I, when American soldiers wore rather flat helmets, any headset could be worn with them. But in this war, the helmets come well down over the sides of the head. Signal men had to remove their helmets when operating radio sets, for it was impossible to wear regular headphones under them. This increased their liability to head wounds and made listening difficult, for the noises of battle leaked past the "muffs."

Signal Corps engineers at the Laboratories at Fort Monmouth, New Jersey, in cooperation with electrical engineers of American industry, set to work to design a new headset, and after months of experiment arrived at the answer.

The new headset is small—with its flat, narrow headband, it fits easily under the new helmet. It provides more dependable communication than any headset previously used, for one part of it is a small, soft plug which fits into the orifice of the outer ear and is a more effective seal against outside noises than were the large rubber cups previously used. It also does away with the discomfort occasioned by the use of the larger rubber ear cups in tropical countries, where the pressure of the rubber on sweat-dampened skin often caused severe irritation. The new headset is designed to permit free circulation of air.

Sanitation, too, is provided. When older types of headset were re-issued, phones which had been in contact with the ear of one wearer were soon against the ear of another. If the new headset is re-issued, a new pair of plug inserts will ordinarily be given to each new wearer; they will be as much his own property as his tooth-brush.

At least one authority on hearing has expressed the definite opinion that blows against the ear of the wearer of a new headset will be less harmful than if no headset, or an older type headset is worn. An object striking the receiver actually causes relatively little shock to the wearer, for its force is cushioned by the rubber-like substance of the insert.

The headband is made of semi-spring steel so it can be bent to the shape of the wearer's head. The inserts are made of neoprene which is considered even better than rubber. On the cord is a clothes clip enabling the operator to attach it to his shirt, thus keeping any pull on the cord from being transmitted to his ears.

The receivers have a higher sensitivity and a higher fidelity of response than those used in former military headsets. This is due to the fact that the signal has less air to vibrate, since the insert focuses the sound from the diaphragm directly in to the ear canal.

When needed, an impedance matching transformer is part of the headset. This enables it to work into a radio having a higher output impedance.

The headset has a flat frequency response curve over its entire useful range.

One of its major advantages is that it can be used in both telephone and radio operation. Its design has three vital industrial advantages. It uses far less material than any previous headset. It uses very little strategic material.

And finally it answers that good old question: Why use two when one will do the trick? For, where formerly the Signal Corps required several types of headsets to operate successfully with the various communications sets employed, the headphones can now be used interchangeably with all ground signal equipment.

Both illustrations Official U. S. Army photos by the Signal Corps.

### Rough-Riding Radios

The toughest of all pieces of radio equipment now engaged in fighting the war to a successful finish is the tank receiver. This brain of the tank, through which it receives the instructions which enable it to take its part in complex actions, is a rugged brother of the automobile radio. Like it, compactness is the greatest virtue, but unlike it, that compactness must be joined with an ability to resist rough handling which was practically inconceivable to manufacturers of auto sets.

Just converted to tank radio production, experts for one of these organizations protested what appeared to be fantastic specifications. The demands were nonsensical, they insisted. Tank radios were in principle very little different from those used by the police in their scout cars.

A demonstration was necessary to convince them. A police radio was installed in a tank and given a ride over rough terrain for just one mile. Then the remains were returned to the factory experts. After one glance at the wreck, they agreed that the Signal Corps' specifications were conservative. Not only were tubes broken but a large number of the apparently solid soldered joints had come apart, and even the coils were partly unwound.

Rough handling is only one of the troubles of tank radio. Another is interference. To combat this, all tank radios use the principle of frequency modulation, which permits static-free and fairly clear conversation among the crew, and from one tank to another. The problem of mechanical interference is not so easy to solve, and such things as the grinding of gears, clanking of heavy tracks, and the deafening blasts of the gun are now the greatest obstacle to easy communication.



How the new U. S. Army headset looks in action.



Left—Control room, from which planes are guided. Center—Intercept officers and plotters report "enemy" planes. Right—An interception on the field of battle. Army Air Forces Photos

# RADIO PLANE ROBOT

(Cover Feature)

**T**HE latest in air defense and tactical research methods is this new system worked out by the Army Air Forces School of Applied Tactics at Orlando, Florida. It comprises the largest military operational map known to exist at the present time, used in conjunction with a group of all radio-controlled model "jeep planes" which are "flown" over the area by short-wave radio control.

The robot planes are radios on wheels, self-propelled by electric motors fed from storage batteries in their "undercarriages." They are only 18 inches high, 14 inches long and 8 inches wide, and the controllers can determine their course and guide them with the sending set as they would real planes in actual war.

The map over which they "fly" on wheels covers the floor of a huge auditorium. It measures 97 by 113 feet and represents an area of 50,000 square miles of territory surrounding the strategic city of Shanghai. This particular area was chosen because it has not been fought over with air equipment comparable to that now available. Thus it is a practically unworked field of air strategy. Students who have already re-fought in their classes the great air battles of the South Seas and Africa may now attack entirely new and unsolved problems.

The planes are controlled entirely by short-wave radio from the hidden controllers' room. Speed and "altitude" are under control at all times. The new observer is invariably awed to see the little cars moving across the map without any apparent aid or guidance.

## SOME THEORETICAL MOUNTAINS

Six inches represents one mile on the large scale of this map. Thus a plane "flying" at 200 miles per hour moves over the floor at about 20 inches a minute. Speeds are adjustable from 120 to 500 "miles per hour." A few theoretical mountain ranges are thrown in to create interest and complicate flying problems, the actual terrain represented by the map being mostly flat delta country. If a controller fails to keep his "plane" at the proper altitude in crossing one of these hypothetical mountain ranges, he crashes and loses his pilot.

Students, seated around and above the map—or field—have a god's-eye view of formations in flight over large areas of

country, can see their reactions in any tactical situation. This would clearly be impossible in actual maneuvers with real planes. Only a small part of the action would be visible under such circumstances. Any attempt to work out the same problems by the customary means of table-maps or blackboards would necessarily be dull and lifeless, and would miss entirely the dynamic quality of such actions so important in the actual field of combat.

According to Lt. Col. William G. Foster, head of the controller's section in the Air Defense Department, the map and synthetic planes give the controller better practice than the actual use of aircraft. Besides the expense of using planes, there is no risk to military personnel and with the use of robots, an enemy situation can be presented to interfere with the controller's course. He must meet and counter the enemy successfully in order to complete his problem and mission.

Still another value is in devising new tactics. When fighter pilots and controllers have seen American tactics and the tactics of the enemy, our own weaknesses appear. Then with the aid of the map and synthetic planes to move over it at any desired speed, tactics to meet these developed by the enemy are worked out, as well as original approaches and methods of attack.

## THE CONTROL ROOM

Intercept officers and plotters in the control room present a scene indistinguishable from one in which actual planes are guided over a real field of combat. The WAC plotters keep tab on the positions of the "planes" and note the course and speed of enemy invaders. The large table map they use is an exact replica of the big map over which the robots are guided. The chief controller depends on this map for his exact knowledge of the relative positions of "friendly" and "hostile" planes. Contact with the field of action is maintained by microphone.

Just to lay out the map with its actual area of 10,961 square feet took Lt. H. D. Bennet and five helpers an entire day. A crew of painters, using spray guns, worked another week.

The robot-planes are the product of evolution, having started some months ago as scooters, on which the pilots propelled

themselves at orders of the controller. Semi-automatic planes, electrically propelled and controlled by pilots in the field through orders over the handy-talkie developed into the present completely automatic set-up, in which the movement of anything from a single plane to an entire wing moves at the command of a radio dial.

## TESLA SAW RADAR FIRST?

One logical contender has not been heard from—for the very good reason that he died a few months before the public announcement of Radar. Yet he described the action and application of the instrument in at least as much detail as recent releases, and did it, not in 1931 or 1922, but in 1900!

As you have no doubt guessed, that man was Nikola Tesla. In an article on the possible uses of wireless, published in the *Century Magazine*, June, 1900, he stated:

"That communication without wires to any point of the globe is practical with such apparatus would need no demonstration, but through a discovery which I made I obtained absolute certitude. Popularly explained, it is exactly this: When we raise the voice and hear an echo in reply, we know that the sound of the voice must have reached a distant wall or boundary, and must have been reflected from the same. Exactly as the sound, so an electrical wave is reflected, and the same evidence which is afforded by an echo is offered by an electrical phenomenon known as a 'stationary' wave—that is, a wave with fixed nodal and ventral regions. Instead of sending sound-vibrations toward a distant wall. I have sent electrical vibrations toward the remote boundaries of the earth, and instead of the wall the earth has replied. In place of an echo I have obtained a stationary electrical wave—a wave reflected from afar.

"Stationary waves . . . mean something more than telegraphy without wires to any distance . . . For instance, by their use we may produce at will, from a sending station, an electrical effect in any particular region of the globe; we may determine the relative position or course of a moving object, such as a vessel at sea, the distance traversed by the same, or its speed."

Possibly, then, the whole problem can be solved by all parties agreeing to acclaim Tesla as the real "Father of Radar"!

# ARMY FIELD PORTABLES

*The extensive use of short-range radio communication apparatus is one of the great features differentiating this from previous wars. The tempo of modern combat rests on the tank-radio, the walkie-talkie and the swift interchange of information between ground and air forces. Some of the smallest of these transmitter-receivers are described in this article.*

**T**HE United States Signal Corps is responsible for the Army's communication system, and for the ground communication of the U. S. Army Air Force. To maintain the lines of communication special types of transmitters and receivers are required.

Not many facts have been published about the sets used by the Corps. It might therefore be interesting to give some details about a few of the pack sets—or, as they have been aptly styled—walkie-talkies, at present in use.

One of the most interesting of the transmitter-receivers used by the U. S. Army is the type 511. Although originally designed for cavalry, this set is now being extensively used by the infantry for communication between company and battalion. Circuit details of the set—which is fixed-tuned on six frequencies—are not available, but some of the salient features in design may be given.

"Miniature" technique is employed in the design of this nine-tube set, which is housed in a metal case measuring approximately 6 x 6 x 8 inches, mounted on a heavy spike 3 feet 6 inches long. Although intended for insertion in the cavalryman's stirrup bucket, the spike is useful for inserting in the ground.

Access to the tubes and other parts is gained by sliding the base plate down the spike. This reveals a second plate, which,

when withdrawn, comes away with the shield-cans of all the tubes. Incidentally, rubber cushioning is provided in each tube-shield.

The joints of the case are rubber-faced to render them waterproof except under most unfair treatment; the set can be passed through water without suffering damage, but cannot be left permanently submerged.

When extended, the 6-foot telescopic aerial, fitted to the top of the case, switches on the set. The send-receive switch is fitted at the base of the aerial where it is accessible and easily depressed. A multiple cable from the set is connected by means of a 9-way plug to a case measuring approximately 10 x 9 x 2 inches, which is carried on the operator's chest. This case contains the combined A and B batteries, spare oscillator coil and the combined microphone-speaker.

This interesting set, weighing 16 pounds complete, has an appreciable range and has been used with considerable success in North Africa and Guadalcanal.

Photographs have recently appeared in the lay press of another Army set, which has been called the "handy-talkie." This transmitter-receiver, used for communication between platoon and company, is about 14 inches long. It is used like the hand-piece of a modern desk telephone.

The same miniature technique of the 511

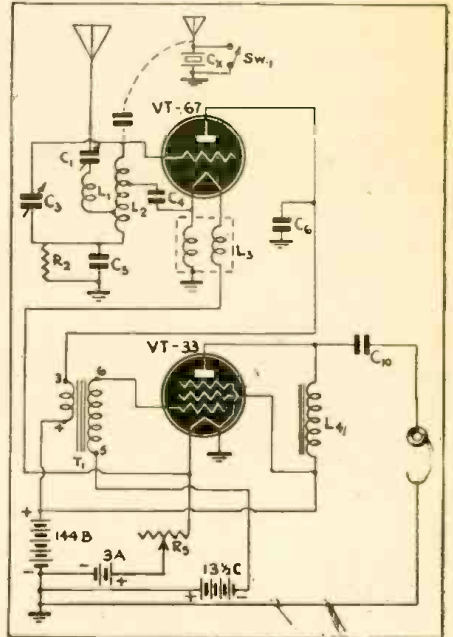

The walkie-talkie in use as a receiver. The oscillator is now a detector, and the modulator an audio amplifier.

is employed in the design of this set, which has 7 tubes and weighs approximately 5 pounds. Very few details are available regarding the circuit. Like the set already described it is switched on by extending the short telescopic aerial.

The original "walkie-talkie" pack set is a 2-tube combined transmitter-receiver of considerably larger size and weight. The whole outfit complete with two telephone hand sets, telescopic rod aerial, spare tubes and batteries is carried in a canvas haversack on the back of the operator, and weighs approximately 27 lbs.

This set, although now obsolescent, is still used in considerable quantities in the Army.

When used as a transmitter one plate functions as the oscillator in a modified type of crystal-controlled Hartley circuit; the plate being maintained at R.F. ground potential. The second tube functions as the amplifier of the Heising (constant current) modulation system. For reception these tubes operate, respectively, as super-regenerative detector and A.F. amplifier.

The set has a frequency range of from 52.80 to 65.80 megacycles using one oscillator coil. There is a separation of 400 kc. between the 33 available frequencies.

Power for the set is provided by a block battery, which, when continuously operated, has a life of approximately 20 hours. When used intermittently the effective life of the battery is, of course, two or three times as long.

The set is housed in an aluminum alloy case. A plug on the bottom of the case is inserted directly in the socket on the top of the battery. Among the accessories is a

(Continued on page 763)

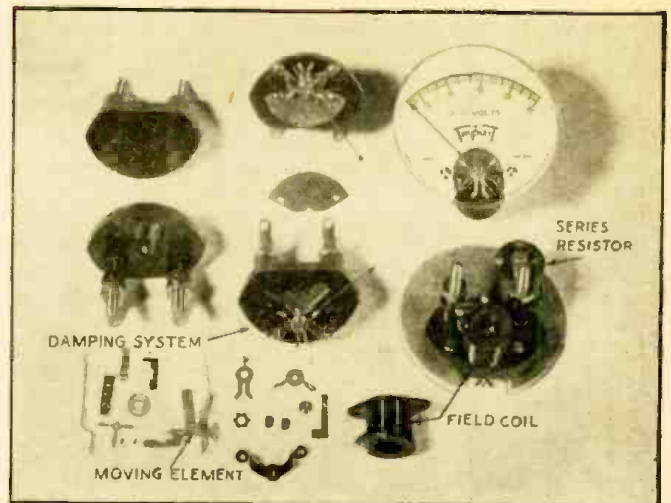

Photo by U.S. Army Signal Corps

A U.S. Army Signalman on maneuvers, using the handy-talkie. This, though not the most recent, is probably the most universally used of all the small Army transceivers at the present time.

# REPAIRING AC METERS

By F. J. LINGEL\*



(Photo courtesy Triplett Electrical Instrument Co.)

**A** ROUGH picture of servicing methods for moving-coil type direct current meters was given in the previous two articles (*Radio-Craft*, May and June, 1943). No mention was made of the moving-iron type alternating-current instrument. These are not used as extensively as are direct-current meters, but have a number of applications. Even in test instruments, alternating-current meters are occasionally of the moving-iron type, and they are often found on the panel of a radio transmitter. The filament voltmeter is usually a moving-iron type. So is the line voltage meter sometimes used in making adjustments to compensate for variations in line potential.

Moving-iron meters consist of the following parts:

**FIELD COIL**, generally wound with several thousand turns of fine enameled copper wire in the case of voltmeters and with a few turns of heavy wire in the case of ammeters. The field coil may either be wound on a bakelite form or else made self-supporting. It is held in position around the moving element by screws or a suitable clamp and in general may be removed without disturbing the moving element itself.

**MOVING ELEMENT**, which as a rule consists of a moving iron vane and a fixed vane, arranged to repel each other in a so-called book type moving-iron system. The field coil is wound around the iron vane with its axis parallel to the axis of the moving element. At a given moment in an alternating current circuit, the top edges of both vanes will be polarized north and the bottom edges of both vanes will be polarized south in such a way as to cause the vanes to repel each other.

\*Triplett Electrical Instrument Co.

At another part of the cycle, both top edges will be south and both bottoms north. The effect is still to repel, and the repulsion is in proportion to the strength of current flowing through the meter.

The "book-type" element gets its name from its construction. This is similar to the covers of an empty loose-leaf book. The front cover of the book is held rigidly in position against a field coil and is called the fixed vane. The back cover of the book opens and closes against the front cover and is called the moving (iron) vane. With zero current flowing through the field coil, the vanes are close together, as in a closed book. When current flows through the field coil the vanes gradually move apart as in a partly opened book.

**THE DAMPING SYSTEM** usually consists of a lightweight aluminum vane moving in a closed air chamber. The air damping chamber is generally molded into a bakelite plate and is covered with a thin brass sheet held in place by two screws directly under the dial. The damping chamber eliminates wide oscillation of the pointer as the line voltage varies.

**THE SERIES RESISTOR**, used in voltmeters, is connected in series with the field coil to give the proper full-scale deflection at the required voltage.

The other parts are essentially the same as those used in D.C. instruments, such as pivots, jewels, hairsprings, scale plate, pointer, etc.

## COMMON TROUBLES OF A.C. METERS

Repair of moving-iron meters is often simpler than that of the moving-coil type, as they are more simply and often much more ruggedly built than direct current

meters. Their troubles are fewer and easier for the skilled serviceman to remedy. Among the most common are:

**BURNOUT**. This may occur in voltmeters or milliammeters. It may occur from excessive overload or power-line surge and will result in an open field coil in some cases and a shorted turn field in others. If the field is open, the meter will read zero; in the case of a shorted turn the indication may be 10 to 50 per cent lower than normal.

Ammeters are generally free from burnout as they are wound with few turns of heavy wire.

**PIVOTS AND JEWELS**. Under severe vibration and shock, these may become damaged or dirty. Pivots may become dull.

**DAMPING VANE**. Sticking or erratic motion of the pointer may be caused by lint or other dirt in the damping box, which contacts the vane and prevents its free motion.

**SERIES RESISTOR**. This is subject to the same troubles as the series resistor in a D.C. voltmeter.

## A FEW SIMPLE REPAIR METHODS

In the case of a burnout, if the coil is not badly burned, it may be possible to unwind the sections, repair the broken or shorted piece and rewind. An "open" can of course, be detected by the break in the wire. The shorted section can be determined by connecting an ohmmeter across the ends of the wire and then noting the indication as the wire is removed. A sudden rise in the reading will indicate that the section with the shorted turn has been reached.

If the field coil is badly damaged by the burnout, a new one can be wound. Enameled copper wire of the same size as that in the burned-out coil should be used. The size may be determined by measuring the diameter with a micrometer, or by taking a section of the wire (approximately three feet long) and measuring its resistance. The wire to be used for replacement can then be determined from the wire table available in most handbooks.

A new coil can be wound on a lathe or made carefully by hand, keeping the turns neat, uniform and as closely wound as possible.

## ADJUSTING THE FIELD COIL

After the field coil has been completely wound, but before it is baked or varnished, mount it in the meter and adjust for full scale deflection by removing turns. This can be done with voltmeters, milliammeters and low range ammeters. Voltmeters may also be adjusted by changing the amount of series resistance. High range ammeters

(Continued on page 752)

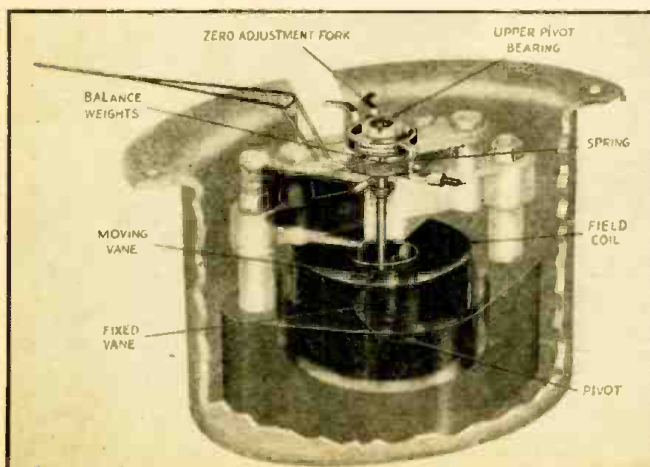

Cutaway view of moving-iron meter. It will be seen that the fixed vane comes to a V-point. Thus repulsion causes the moving vane to try to slide past in the direction where there is less iron to oppose it.

(Photo courtesy Weston Electrical Instrument Co.)

FARNSWORTH RADIO

MODELS DC-90, DK-91,  
DK-92, DK-93



Above is the Model DK-93. Turn-table is shown in the inset, lower right.

ELECTRICAL SPECIFICATIONS

Watts At 117 Volts A. C. BK Models 100, BC Models 90  
Voltage A.C. 105-125  
Nine Tube A.C. Three Band Superheterodyne  
Broadcast Band 540 — 1720 K.C.  
Spread Band 9.4 — 12.1 Mc.  
Short Wave Band 5.4 — 18.1

TUBE COMPLEMENT

6SK7 R.F. Amplifier 6SQ7 Detector & Audio  
6SA7 Mixer 6SQ7 Inverter & A.V.C.  
6J5GT Oscillator 6V6G Output  
6SK7 I.F. Amplifier 6V6G Output  
5Y3G Rectifier

ALIGNMENT INSTRUCTIONS

An output meter and a signal generator are required for proper alignment of these sets. The oscillator should be calibrated at the following points, 455 Kc., 600 Kc., 900 Kc., 1500 Kc., 1720 Kc., 2.0 Mc. 5 Mc., 5.5 Mc., 6 Mc., 9.5 Mc., 12 Mc., 16 Mc., and 18.0 Mc. Always keep the output of the signal generator as low as possible to prevent A.V.C. action and false settings. Connect the high side of the generator to the antenna terminal and the low side of it to the ground terminal.

After pointer has been set on BC and calibrations checked, with range switch on Band Spread (Full CCW) set condenser so pointer is on 12 Mc. on "Foreign Spread Band." Set "Spread Band" Osc. trimmer for maximum output. Check for image on 11.1 Mc. (A weakened signal should be heard.) Align antenna Band Spread trimmer for maximum signal. Turn condenser so pointer is on 9.5 Mc. Adjust Spread Band Osc. padder for maximum signal. Check for image. (No signal should be heard on 10.4 Mc.) Align Antenna Band Spread padder for maximum signal. Go back to 12 Mc. and repeat above. If much readjustment has to be made on trimmers, the padders must be checked again. Great care must be taken in adjusting Band Spread trimmers. Image must be checked. A fibre screw-driver must be used to adjust band spread.

\* Tighten oscillator trimmer screw for maximum capacity, then unscrew until second peak is secured.

\*\* Tighten R.F. trimmer screw for maximum capacity, then unscrew until first peak is secured.

Note A—Set gang at minimum.

Note B—Strongest signal and rock gang.

TABULATION FOR ALIGNMENT

Steps in Series With Antenna	Set Generator At	Set Gang At	Adjust	Located	To Obtain
1 250 mmf.	455 Kc.	Note A	2nd I. F. Trimmers	Top of I.F. Trans.	Max. Output
2 250 mmf.	455 Kc.	Note A	1st I.F. Trimmers	Top of I.F. Trans.	Max. Output
3 "	"	Push Station Button	Wave Trap Trimmer	See Fig.	Min. Output
4 "	1720 Kc.	1720 Kc.	B. C. Osc. Trimmer	" "	Max. Output
5 "	1500 Kc.	1500 Kc.	B. C. Ant. Trimmer	" "	Max. Output
6 "	600 Kc.	Note B	600 Kc. Pad	" "	Max. Output
7 Recheck	1500 Kc.	—	—	" "	Max. Output
8 400 Ohms	18 Mc.	18 Mc.	S. W. Osc. Trimmer*	" "	Max. Output
9 "	16 Mc.	16 Mc.	S. W. Ant. Trimmer**	" "	Max. Output
10 Check	6 Mc.	—	—	" "	Max. Output
11 400 Ohms	12 Mc.	12 Mc.	S. B. Osc. Trimmer*	" "	Max. Output
12 "	12 Mc.	12 Mc.	S. B. Ant. Trimmer**	" "	Max. Output
13 "	9.5 Mc.	9.5 Mc.	S. B. Osc. Padder	" "	Max. Output
14 "	9.5 Mc.	9.5 Mc.	S. B. Ant. Padder	" "	Max. Output
15 Recheck	12 Mc.	—	—	" "	Max. Output

PUSH BUTTON SET UP

To prevent the buttons from being set up on the wrong stations a signal generator should be used. The button to the extreme right is the manual tuning button.

Adjust the lower screw (see fig.) first as this is the oscillator; then adjust the upper screw for maximum output.

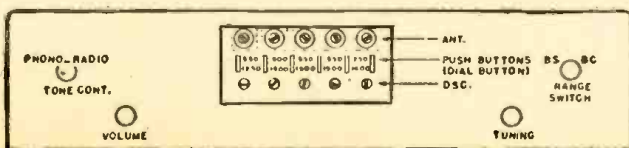

Button Layout

STRINGING DIAGRAM

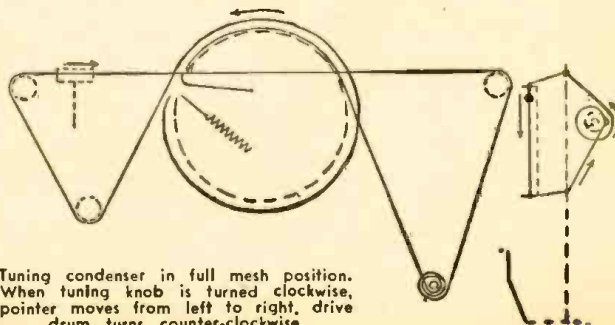

Tuning condenser in full mesh position. When tuning knob is turned clockwise, pointer moves from left to right, drive drum turns counter-clockwise.

# Radio Service Data Sheet

327

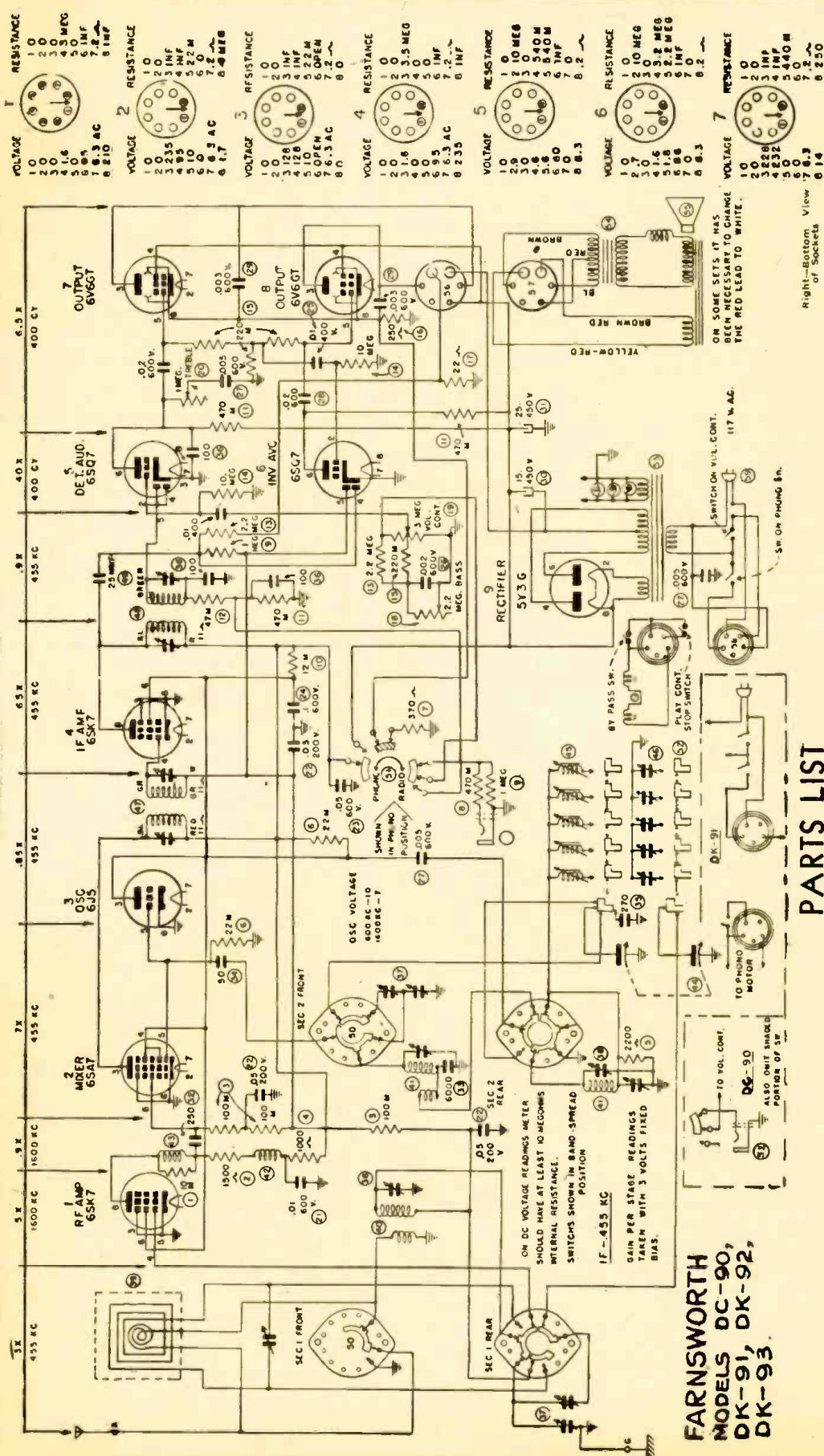

Right-Bottom View of Sockets

- |  |  |   |  |  |  |  |  |  |
|--|--|---|--|--|--|--|--|--|
| <b>1</b><br>RESISTANCE<br>VOLTAGE<br>1 0<br>2 0<br>3 0<br>4 1.6<br>5 0<br>6 0<br>7 6.3 AC<br>8 210<br>9 1M | <b>2</b><br>RESISTANCE<br>VOLTAGE<br>1 0<br>2 0<br>3 235<br>4 95<br>5 10<br>6 1.7<br>7 2<br>8 6.3 AC<br>9 1M | <b>3</b><br>RESISTANCE<br>VOLTAGE<br>1 0<br>2 0<br>3 128<br>4 128<br>5 10<br>6 OPEN<br>7 1.3 AC<br>8 0<br>9 0 | <b>4</b><br>RESISTANCE<br>VOLTAGE<br>1 0<br>2 0<br>3 1.6<br>4 0<br>5 0<br>6 95<br>7 6.3 AC<br>8 235<br>9 0 | <b>5</b><br>RESISTANCE<br>VOLTAGE<br>1 0<br>2 0<br>3 0<br>4 0<br>5 0<br>6 60<br>7 0<br>8 8.3 | <b>6</b><br>RESISTANCE<br>VOLTAGE<br>1 0<br>2 0<br>3 0<br>4 1.6<br>5 0<br>6 95<br>7 6.3 AC<br>8 235<br>9 0 | <b>7</b><br>RESISTANCE<br>VOLTAGE<br>1 0<br>2 0<br>3 0<br>4 1.6<br>5 0<br>6 95<br>7 6.3 AC<br>8 235<br>9 0 | <b>8</b><br>RESISTANCE<br>VOLTAGE<br>1 0<br>2 0<br>3 235<br>4 95<br>5 10<br>6 1.7<br>7 2<br>8 6.3 AC<br>9 1M | <b>9</b><br>RESISTANCE<br>VOLTAGE<br>1 OPEN<br>2 1M<br>3 1M<br>4 OPEN<br>5 OPEN<br>6 OPEN<br>7 OPEN<br>8 250<br>9 1M |
|--|--|---|--|--|--|--|--|--|

ON SOME SETS IT HAS YELLOW-RED

ON SOME SETS IT HAS THE RED LEAD TO WHITE.

## PARTS LIST

- | Ref. No. | Description                                |
|----------|--|
| 1        | 10 M Ohms                                  |
| 2        | 1500 Ohms                                  |
| 3        | 1000 Ohms                                  |
| 4        | 1000 Ohms                                  |
| 6        | 2200 Ohms                                  |
| 8        | 22 M Ohms                                  |
| 9        | 1 Meg.                                     |
| 10       | 12 M Ohms                                  |
| 11       | 470 M Ohms                                 |
| 12       | 47 M Ohms                                  |
| 13       | 47 M Ohms                                  |
| 14       | 2.2 Meg.                                   |
| 15       | 220 M Ohms                                 |
| 16       | 250 Ohms                                   |
| 17       | 22 Ohms                                    |
| 18       | 2.2 Meg. Bass Control                      |
| 19       | 3 Meg. Volume Control                      |
| 20       | 1 Meg. Treble Control                      |
| 21       | .01 Mfd. 600 V.                            |
| 22       | .05 Mfd. 200 V.                            |
| 23       | .05 Mfd. 600 V.                            |
| 24       | .1 Mfd. 600 V.                             |
| 25       | .01 Mfd. 400 V.                            |
| 26       | .002 Mfd. 400 V.                           |
| 27       | .005 Mfd. 600 V.                           |
| 28       | .02 Mfd. 600 V.                            |
| 29       | .003 Mfd. 600 V.                           |
| 30       | 15 Mfd. 450 V. Electrolytic                |
| 31       | 25 Mfd. 450 V. Electrolytic                |
| 32       | 250 Mfd.                                   |
| 33       | 6000 Mmf.                                  |
| 34       | 50 Mmf.                                    |
| 35       | 270 Mmf. Silver Mica                       |
| 36       | 100 Mmf.                                   |
| 37       | Band Spread Antenna, Osc. Trimmer & Padder |
| 38       | SW Antenna Trimmer & Osc. Padder           |
| 39       | Loop Antenna                               |
| 40       | Short Wave Antenna Coil                    |
| 41       | BC and SW Oscillator Coil                  |
| 42       | Amplifier                                  |
| 43       | Amplifier                                  |
| 44       | Two Gang Condenser                         |
| 45       | Push Button Oscillator Coils               |
| 46       | Push Button Trimmer                        |
| 47       | 1st I.F. Transformer                       |
| 48       | 2nd I.F. Transformer                       |
| 49       | 25 Mmf. Mica                               |
| 50       | Band Switch                                |
| 51       | DK-91, DK-92, DK-93 Radio                  |
| 52       | Phono Switch                               |
| 53       | Power Transformer                          |
| 54       | Output Transformer                         |
| 55       | Speaker                                    |
| 56       | Speaker Socket                             |
| 57       | Speaker Plug                               |
| 58       | AC Cord                                    |

# OUTPUT TRANSFORMERS

By FRED SHUNAMAN

**O**UTPUT TRANSFORMERS are among the easiest of all to repair. It is only necessary to unwind them carefully, noting the number of turns and the way the ends are fashioned, then rewind again with the correct size wire and the same number of turns. Unlike power transformers, they are seldom burned to a point where counting turns is impossible. It

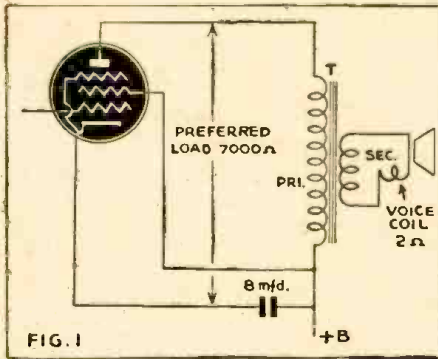

is much easier to get all the turns back in the same space than when rewinding a power transformer. The output has two windings only—the power transformer several, and each winding has its own problem of terminals and insulation. Methods of rewinding transformers of all kinds were described in the September, 1942 issue of *Radio-Craft*.

In spite of their simplicity, many a radio-man has no idea of how output transformers do their job. They are simply mysteries stuck in between the output tube and the speaker. It is with the idea of clearing up

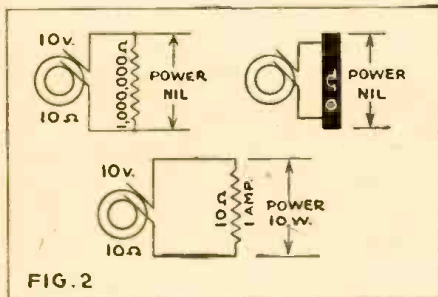

some of this mystery, and to help servicemen and others in adapting transformers on hand to jobs slightly different from the ones they were designed to do, that this article is written.

Let us look at Fig. 1. The first question we ask is, why an output transformer at all? Why not connect the voice coil of the speaker directly in the plate circuit? This used to be done with the old magnetic speakers, and it worked all right. The answer, "impedance mismatch", is known to everybody but not understood by quite that many. The preferred load for the pentode tube shown is around 7,000 ohms, and the resistance of the voice coil is only about 2.

What of it? Fig. 2 will give us an answer to that. Here we have a generator with an output of 10 volts, and an internal impedance of 10 ohms (due to the wire with which it

is wound). We want to get the maximum amount of power out of this generator, and will try various loads. As a start, we connect one with a resistance of 1 megohm. Very little power is taken by this load—hardly enough to measure—for power is the product of volts and amperes, or the square of the current times resistance. Either way you figure it, you get about 100 millionths of a watt. This is no way to get power out of our generator, so we will try a heavy bar of copper—resistance too low to measure with any ordinary instruments. Heavy currents flow, but because of the extremely low resistance of the bar, practically no voltage ( $I \times R$ ) appears across it, so again we get a result approximating zero.

Next let's try a load of 10 ohms. We now get a current of one ampere in the load. By either of the above-mentioned methods of figuring wattage, we find the power in the load to be 10 watts, about 1/70 horsepower. Substitute a 5-ohm and a 20-ohm resistor for the load, and you find that the most efficient transfer of power takes place when the impedance of the load and that of the source are equal. Our 2-ohm voice-coil would act much the same as the copper bar of Fig. 2. Practically all the power generated by the tube would be wasted inside itself, and a negligible fraction turned into useful power in the voice coil. If we want to get any power out of the power tube, we have to match it up with an impedance somewhere near its own.

Now back to Fig. 1, and see what we can do to get an efficient transfer of power. Can we decrease the impedance of the tube, increase that of the voice coil, or find some other way of bringing them together?

Impedance of a tube is due chiefly to the resistance of the space between cathode and anode. It is different for different tubes, and, in any given tube, varies with the voltage applied to the plate, and especially to the several grids between cathode and plate. Tubes now in common use as amplifiers call for a plate load between 3,000 and 7,000 or more ohms. These load impedances are not equal to the internal impedance of the tube. Considerations of fidelity as well as power efficiency get into the argument, and some power efficiency is sacrificed to get better quality of reproduction. The load impedance is a compromise between the best value for maximum power transference and that for minimum distortion.

We can do little to reduce tube impedance. In fact, the tubes used today have a higher impedance than those which were common some years ago. Neither can we raise voice coil impedance a great deal. The coil should be as small and light as possible if it is to be sensitive and reproduce signals faithfully. Any increase in bulk would cut its sensitivity—an increase in weight would harm its fidelity. The logical thing is to use some kind of coupling unit. Here is where the transformer comes in.

In any transformer, such as the one in Fig. 3, the ratio of voltages and of impedances between primary and secondary depends on the turns ratio. If the primary has 1,000 turns and the secondary 500, a voltage of 120 on the primary will produce 60 volts across the secondary. The voltage ratio is the same as the turns ratio. If a 60-

volt lamp, drawing 1 ampere, is connected to the secondary, it will be found that the current in the primary is only 1/2 ampere. This is reasonable—we are using 60 watts in the secondary and should expect the same wattage to be supplied to the primary.

The impedance of the secondary is 60 ohms (60 volts/1 ampere). The primary impedance is 120 volts/1/2 ampere, or 220 ohms. With a voltage ratio of 2, the impedance ratio is 4. If we try a secondary of 333 turns, the voltage will be 1/3 that of the primary, but the impedance will be only 1/9, or—in reverse phrasing—a turns ratio of 1:3 results in an impedance ratio of 1:9. The impedance ratio varies as the square of the turns ratio, 4 being the square of 2 and 9 of 3. (For a number of examples and an elementary treatment of transformer action, see "Lenz's Law in Modern Speech," in the February issue.)

This impedance ratio, rather than the voltage change, is the important thing about output transformers. This is why so many

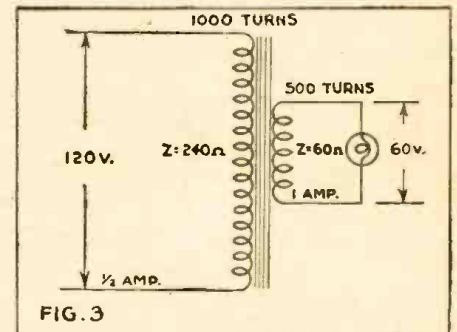

students and servicemen are unclear about them. They understand the voltage-changing function, but do not know just how the transformer acts as a changer of impedances.

To find out how, as well as why, let us tear down transformer T of Fig. 1. The primary of one such consisted of 2990 turns of No. 36 wire, the secondary, 60 turns of No. 21. The core cross-section was 5/8 x 1 inch, and the window (if anyone is interested), was 3/8 x 1 1/8 inch.

This transformer is shown in Fig. 4. The turns ratio is roughly 60 to 1. The impedance ratio—the square of that—is 3600 to 1. If the voice coil has a resistance of 2 ohms,

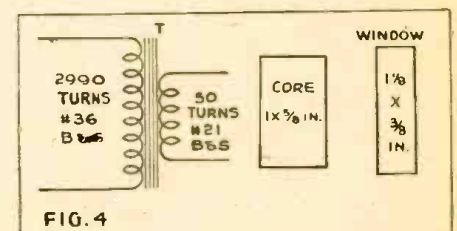

it will reflect back into the primary an impedance of 7,200 ohms, practically what we want for this tube. The matching problem is solved. Power is taken from the tube by an impedance of 7,000 ohms, and fed into the speaker from one of 2 ohms.

The next thought likely to come to the reader is: Why not get the proper ratios by (Continued on page 753)



# SERVICING NOTES

## Trouble in . . . .

### . . . . AIRLINE 521, 522

No reception—all voltages O. K.  
 Trouble is due to the input I.F. trimmers, which short due to mica breaking off around the edges.

Remove the I.F. can and install new mica.  
 EARL LASKE,  
 Chicago, Ill.

### . . . . CORONADO 686B

Normal operation on shortwave, nil on broadcast. With finger or aerial on grid-cap of 6L7 and set tuned to 900 Kc., station at 1530 is heard.

Padding condenser, (C6, .0034 mfd.) open. This is the front one of two mica condensers from wave band switch to series padding condenser.

Replace with one of the same capacity, or with a .003 shunted by a variable padder which can be adjusted to bring it to the correct capacity.

W. J. DOUGHERTY,  
 Kincaid, Kan.

### . . . . SILVERTONE (SEARS, ROEBUCK) BATTERY SETS

This note is in regard to Silvertone Battery-Operated Receivers using a type 1G6 tube as the R.F. amplifier and mixer. The complaint in nearly all cases was that the set operated perfectly on either shortwave bands or on the higher-frequency standard broadcast band, but on approaching approximately 800 kc. the set became inoperative and the oscillator even stopped functioning. The tubes in these sets would invariably test OK.

After several attempts at alignment and finding that the sets were in alignment with a signal generator I found that the 1C6 tube though testing OK was giving trouble. In some cases it required nothing more than replacing the 1C6 and some cases showed that the ballast tube had changed value causing a slight discrepancy in the filament voltage. In either case the trouble cleared up and another headache was out of the shop.

LARRY M. STEWART,  
 McComb, Miss.

### . . . . SILVERTONE 6122

Trouble: Excessive hum—all filter and by-pass condensers O.K.

This was cleared up by adding 20 mfd. capacity across cathode resistor of 25L6-G, the output tube of this set.

### . . . . RCA 8K1

The 6L7 pentagrid converter went bad. No other such tube was available. Substituted a 6A8-G with good results. Had to change the tube socket as this particular socket had no soldering lug for the anode-grid connection of the 6A8. A 20,000-ohm, 1-watt resistor was used to drop the voltage to the anode-grid. This was connected directly to the high voltage source of supply and to the anode grid. No extra by-passing was necessary for this resistor.

FRED P. STEINMETZ,  
 Chandler, Indiana

### . . . . PHILCO 38-10

Trouble: Intermittent fading accompanied with hum.

This will usually be found due to an intermittent coupling condenser in the A.F. stage.

FRED HARTMANN,  
 Woodside, N. Y.

### ATTENTION SERVICEMEN!

Do you have any Servicing Notes available which you would like to bring to the attention of the readers of *Radio-Craft*? If so, send them along and if they are published a six months' subscription to *Radio-Craft* will be awarded you. If your notes are illustrated you will be given a one-year subscription.

### . . . . GENERAL TELEVISION MODEL 534

Complaint was broad tuning. The trouble was due to a paper condenser in the oscillator grid circuit of the 12A8-GT tube.

Though this condenser may check good, replace it with a mica condenser of the same value, .00025 mfd. Oscillator grid circuits are a poor place to use paper condensers.

JOHN ROCKI,  
 Milwaukee, Wis.

### . . . . MAJESTIC MODEL 91

Trouble, in two of these sets recently serviced: A buzzing, static-like noise, which ruined reception on the high end of the band.

A .01, 600-volt paper condenser across the line-regulating ballast tube cured this trouble.

FRED T. RICE,  
 Mebane, N. C.

### . . . . RECEIVERS WITH 35Z5's

To repair a set using a 35Z5 tube when the 7.5-volt section of the filament is burned out, simply connect another No. 47 pilot lamp across it. The regular pilot then burns at normal brightness and the filament voltages are all normal. I have seen a number of suggestions on repairing the burned-out section of a 35Z5 but to my mind this is the quickest, easiest and most satisfactory method.

JACK GARREN,  
 Los Angeles, Calif.

### . . . . CANADIAN MARCONI 89-90 & 90

Distortion in these sets, static-like noises and squealing, can all be traced to the inter-stage transformer between the types 1B4 and 30 tube.

Replacing with resistance-capacity coupling remedies the trouble and also improves the tone considerably.

Motor-boating is caused by a defective 8-mfd. condenser, (C-16).

EDGAR WILLIAMS,  
 Baltimore, Ont.

### . . . . A TUBE-CHECKER KINK

I have installed a 6-8 volt pilot lamp connected to the proper tap on my tube checker. Upon inserting a tube in the tester the pilot

will dim down noticeably if the heater element is O.K. This gives a quick filament check. Many times I have found intermittent heaters indicated by the pilot flickering. This saves considerable time, especially on jobs with 13-tubers.

### . . . . OSCILLATING 50L6's

If troubled with severe oscillation in sets using 50L6 or 35L6, try shielding the tube. I have cured a number of cases of the sort. A new 50L6 or 35L6 will do the trick, but is not always at hand.

CLIFFORD C. HORNE,  
 Bloomington, Illinois.

### . . . . EMERSON 108 U4

This had a bad modulation hum that could not be cured by ordinary methods.

The trouble was a poor connection on the jumper connecting the two cathodes of the 25Z5. Voltages were normal but since only one half of the rectifier was working an overloaded (or cross-modulation?—Editor) condition caused the hum.

This was a very hard one, as the bottom of the socket is very inaccessible and the jumper looked all right.

WM. HORVATH,  
 Erie, Penna.

### . . . . LAFAYETTE MODEL 219

(This might be useful in other sets as well.)

Trouble: Weak. Lined up the I.F.'s, noted that the set worked well on a good outside aerial, looked for a trimmer to line up the loop antenna in the set and found none.

Adding a trimmer increased the volume greatly. It would seem that although these loops are matched to the sets at the factory, something may cause them to get out of adjustment later.

C. L. HOLMAN,  
 Danville, Ky.

### . . . . GENERAL ELECTRIC E53

Cuts down to about two-thirds volume with distortion. Will play clear for about 5 minutes and then distort again.

Replace the .01 condenser (C20 on schematic) which is in series with a 27,000-ohm grid resistor from the 500,000-ohm section of the volume control.

### . . . . PHILCO 70

Trouble: No pep at low-frequency end of dial.

Check antenna portion of volume control. The rotor arc does not make good contact.

### . . . . DELCO MODEL R1128

Trouble: Intermittent whistle.

This is due to an open 0.1-mfd. condenser from G2 to ground in 6K7 tube circuit.

W. A. RIEVELEY,  
 Vancouver, B. C.

### . . . . UNITED MOTORS 4052 A.C.-D.C.

Motor-boating at full volume.

Check the condenser from center tap of volume control to ground. Replace with good .00025 mfd. by-pass.

W. J. DOUGHERTY,  
 Kincaid, Kan.

# RADIO WAVES AND

## Aerials Are Not Always What the

**T**HE average beginner's conception of a transmitting antenna is usually woefully inadequate. He imagines the simple system shown in Fig. 1-A\* as including all of the essential elements—a transmitter coupled on the one hand to a vertical or horizontal radiator (either directly or by means of a resonant or non-resonant R.F. transmission line) and on the other hand to the Earth.

Now one of the things we all learn through our studies in scientific fields is that our senses rarely present to us a com-

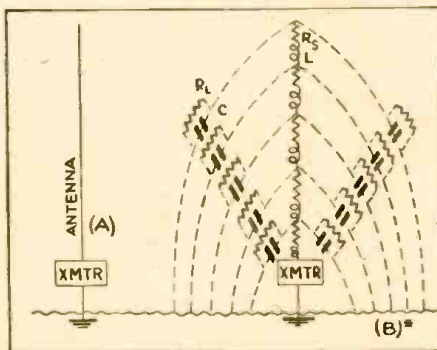

Fig. 1—What an antenna looks like (1-A), and what it is, (1-B).

plete picture of anything. This is no exceptional case, for, where to our eyes a transmitting antenna might indeed look like Fig. 1-A, it has been conclusively demonstrated that electrically it is actually more like Fig. 1-B. Here the antenna is divided into an infinite number of tiny elements ( $R-L$ ) each consisting of the following electrical quantities:

(1)  $L$ , the inductance offered by the individual elemental length of antenna wire to the flow of R.F. current. The reactance imparted by this quantity increases with the frequency according to the relation  $X_L = 2\pi fL$ .

(2)  $R_s$ , the series resistance offered by the elemental length of wire to the current. This, of course, is independent of the frequency.

(3)  $R_L$ , the leakage resistance between the element and Earth or to objects (trees, buildings, etc.) connected to Earth. This occurs as a result of leakage across insulators and even through the air itself.  $R_L$  is greater in damp weather than in dry weather. It is independent of frequency.

(4)  $C$ , the electrical capacitance between each elemental length of the antenna and the Earth or objects connected to the Earth. This reactance decreases as the frequency increases ( $X_C = 1/2\pi fC$ ).

### WHAT ARE STANDING WAVES?

As most of us know, a transmitting antenna must be cut to a certain length for a

\* All figures in this article marked with an asterisk (\*) will contain a straight line representing a transmitting antenna, and the reader should imagine these figures rotated about this line as an axis through 360° to derive the full meaning of the diagram in our 3-dimensional space.

given frequency. It is common practice, in short wave work at least, to cut the antenna to approximately half the wavelength to be used, and then to tune it nicely by means of lumped inductances and capacitances inserted at the base.

Let us imagine a wire in "free space" (i. e., well clear of all trees, buildings, and other conductors, and of the Earth) cut to an exact electrical half wavelength for a given frequency—say, 1000-kc. Such a wire would be for all practical purposes 150 meters long (1000-kc. corresponds to a wavelength of 300 meters, and half of this would be 150 meters, a meter being 39.37 inches.)

Next, let us suppose that we deliver to this antenna a 1000-kc. current from a transmitter. We now have what is known technically as a "half-wave antenna resonating at its natural frequency", for we cut the antenna just  $1/2$  wavelength long for 1000-kc., and we are delivering a 1000-kc. current to it.

Now let us, like the good scientists we try to be, perform a number of experiments to determine just HOW the current and voltage are distributing themselves along our wire:

First, let us break the wire at various intervals along its length and insert good R.F. ammeters (this is a rather expensive project, and we'll not be able to get the meters until after the war!). Then we observe the readings indicated by the meters and find that they are somewhat as shown in Fig. 2-A.

Obviously there can be little or no current at the ends of our wire, and the highest value attained by the current becomes greater and greater as we proceed from either end toward the center where it attains its maximum value.

Now let's take a look at the voltage. A neon bulb would make an excellent voltage indicator, so we shall solder neon bulbs along our wire at regular intervals in order to determine the VOLTAGE relations along the wire, the brightness of each lamp being indicative of the HIGHEST VOLTAGE attained at the point where it is installed. Our results are as shown in FIG. 2-B.

Here we discover just the opposite condition. The voltage attains its maximum value at the ends of the wire, and the highest value reached progressively decreases toward the center where it is zero.

These current-voltage relations, which

### PART I—Nature of Radio Waves

may seem odd to the novice, are frequently encountered in radio, and we say that there is a STANDING WAVE on a wire where they obtain. Let us review them briefly:

(1) On the wire are just one "half wave" of CURRENT and one "half wave" of VOLTAGE.

(2) The CURRENT is zero at the ENDS, and reaches its MAXIMUM only at the CENTER.

(3) The VOLTAGE (just opposite) reaches its full value at the ENDS and is ZERO at the CENTER.

This is difficult to comprehend, but it is what happens. WHY it happens cannot be explained within the scope of this elementary article, as its full explanation requires some mathematics.

Now let us describe two simple mechanical analogies of the above phenomena which will perhaps clarify them somewhat.

(1) The CURRENT FLUCTUATIONS in a half wave antenna may be represented by the vibrations of a stout rubber band held fixed at the ends and plucked at the center so as to vibrate as in FIG. 3-A. Our rubber band would, of course, have to vibrate a million times a second to really represent our 1000-kc. R.F. current.

[CAUTION!!! THE READER MUST BEAR IN MIND THAT THIS IS PURELY AN ILLUSTRATION!! The rubber band merely represents the instantaneous values at points along the wire of the current. Please don't get the idea that the ANTENNA itself is vibrating, or that the CURRENT hops into and out of the wire like our rubber band!!!]

In FIG. 3-A:

(a) An imaginary straight line between A and E may represent the antenna wire.

(b) The MAXIMUM current amplitude is obtained at the center (HDK).

(c) The highest amplitude attained decreases toward either end.

(d) The amplitude is ZERO at either end.

If the reader now imagines that the region ABOVE AE represents POSITIVE values of our alternating 1000-kc antenna current (i. e., represents currents flowing in the direction, let us say, FROM A to E), while the region BELOW AE represents NEGATIVE values (i. e., flowing in the opposite direction), he will have a complete picture

Fig. 2—The R.F. ammeters show how current is distributed along the antenna wire when a signal is being transmitted. Voltage distribution at the same time is shown by the neon bulbs.

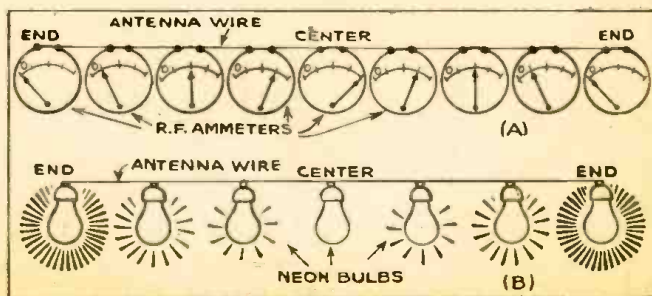

# RADIO ANTENNAS

## New Student Believes Them to Be

By EUGENE P. BERTIN

of the current fluctuations at ANY point on the wire.

For example, at D, the center, the current alternates thru all values between "H-amps. POSITIVE" to "K-amps. NEGATIVE" H and K are the MAXIMUM values attained by the current ANYWHERE on the wire. (That's why our R. F. ammeter here indicated MAXIMUM current in Fig. 2-A.)

At point C, our current alternates thru all values from "+G amps." to "-J amps." G and J are the highest values of current ever attained at C, and note carefully that they are LOWER than H and K which are the highest values attained at the CENTER. (Thus an R. F. ammeter placed here would read LESS than at the center, as in Fig. 2-A.)

Again at B, the current passes through all values smaller than "+F" and "-I" amps., and since these values are still smaller than the highest values attained at C, an R. F. ammeter would read a still lower average current value.

Thus the highest value attained by the current is maximum at the center and becomes progressively LESS toward either end where it is ZERO.

(2) VOLTAGE fluctuations in our wire may be crudely represented by screwing a thin steel strip (as used to hold large packing boxes together) at the center and setting both ends in vibration (Fig. 3-B). Our steel strip would have to vibrate a million times a second to represent adequately our 1000-kc voltage!

[CAUTION! This, too, is purely an illustration!! The antenna doesn't vibrate, and it would be an extraordinary voltage indeed that hopped in and out of its wire like our steel strip which merely represents in-

stantaneous voltage values along our wire!]

In Fig. 3-B:

(a) An imaginary straight line between A and D may represent the antenna wire.

For example, at the ENDS of the wire (A and D) the voltage passes successively through all values between "+E or +E' volts" and "-H or -H' volts" as the 1000-kc

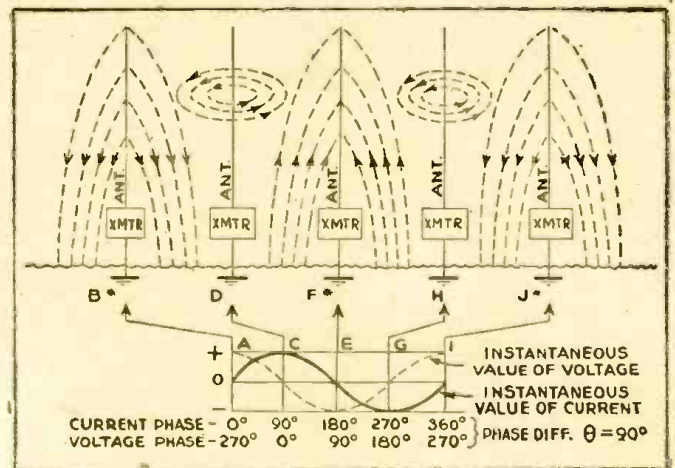

Fig. 4—The electrostatic and electromagnetic fields around a vertical antenna during a complete cycle of R.F. antenna voltage and current, and below, the relative phases of voltages and currents setting up these fields.

(b) The MAXIMUM voltage amplitude is obtained at the ends, A and D.

(c) The highest amplitude attained decreases from either END toward the center.

(d) The voltage amplitude is ZERO at the center.

If the reader now imagines that the region above AD represents POSITIVE values of voltage, while the region below AD represents NEGATIVE values of voltage and the line AD itself represents ZERO voltage, he will have a good picture of a "standing wave" of voltage, and of the VOLTAGE FLUCTUATIONS at ANY POINT along the wire.

alternating R. F. voltage alternates, and since these are the HIGHEST values attained by the voltage ANYWHERE along the whole wire, we see why it was that our neon lamps glowed most brilliantly at the ENDS of our wire (Fig. 3-B).

At B the voltage alternates between all values smaller than "+F and -I volts" and NEVER EXCEEDS THESE VALUES, which, note carefully, are less than E or H, the highest values attained at the ends. That is why our neon lamps placed here glowed less brilliantly than at the ends.

Again at C, the voltage alternates through all values between "+G and -J volts" which limiting values are still less than the peak values at B. Thus we should expect a neon lamp here to be dimmer still, which was indeed the case (Fig. 2-B).

THUS THE HIGHEST VALUE ATTAINED BY THE VOLTAGE IS GREATEST AT THE ENDS AND BECOMES PROGRESSIVELY LESS TOWARD THE CENTER WHERE IT IS ZERO.

Incidentally, it should be mentioned that in order that our crude illustration might convey the correct picture of voltage POLARITY along the wire, it is necessary to imagine that while the RIGHT half of the steel strip is vibrating UP, the LEFT half of the strip is vibrating DOWN, and vice versa. In other words, the POLARITY of the voltage is opposite on opposite ends of the wire, the RIGHT half going through POSITIVE values, while the LEFT half goes through NEGATIVE and vice versa.

Now the writer has been attempting to show as clearly as possible how the R. F. current and voltage are distributed in a resonant wire in free space. We have seen that in such a wire, resonant at its natural

(Continued on page 750)

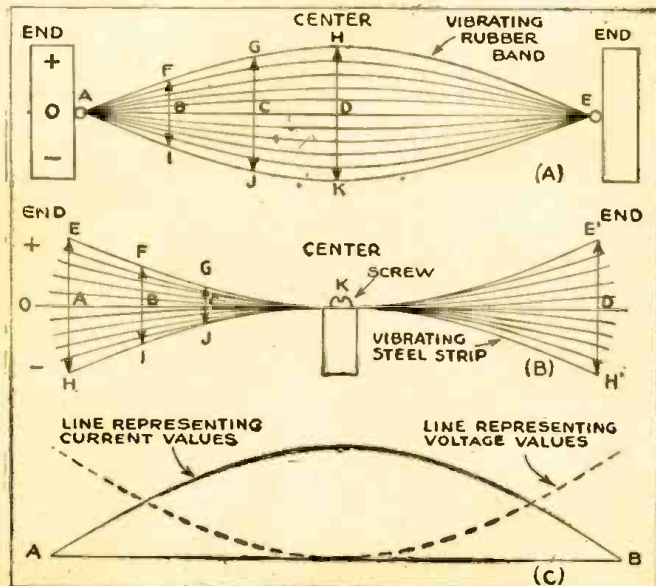

Fig. 3—Another view of current and voltage distribution. At A are shown the values through which current may pass during a cycle, at any point on the antenna wire. Similar voltage values are shown at B, while at C, the average current and voltage values are shown in single-line graphs.



The complete amplifier described by Mr. Edmonds in this article.

# FIXED BIAS

## More Power-

By DEAN S.

**H**OW many experimenters, like the author, have looked at a small commercial radio filling a large room with crystal-clear volume and have thought it would be nice to have an amplifier of such small size that would give such high undistorted output. Perhaps you have looked in the back of the set and been amazed to find a single pentode or tetrode such as the 6F6 or 6V6 responsible for all the volume. You have taken down the number of the tube and gone home and immediately built up a little class A1 job, thinking that the use of that tube would cure all amplifier problems. And you have been cruelly disappointed. All voltages, resistances, and loads test exactly as they should to conform to the ratings given in the tube manual for that tube, and yet at a very low level compared to the level of the commercial set, terrific distortion sets in, and the output stage turns the sine wave on its grid into a dreadful goulash of flattened wave tops and curious peaks in the plate circuit. If you have put away an attempt like this as a failure, get it out again, for there's fun ahead.

It's ten to one that you used something like the circuit of Fig. 1 when you decided to build a phono amplifier with this magic tube with which to amaze your friends. This is the typical circuit we all know well.

You looked up the correct ratings for the tube, used mathematics correctly to determine the resistance values, and bought the right output transformer. Why does the set work so much less well than the commercial amplifier? One of the answers is, it uses self-bias, while the commercial probably has some form of fixed bias.

### FIXED BIAS IS FEASIBLE

Let us see exactly what we are up against. In the first place, the ordinary cathode-biased class A1 stage proves to be highly inefficient and low in fidelity for two main reasons: (1) the bias voltage, which should be very stable, is varied by being developed by a varying current, i.e., the plate and screen current of the tube, and, (2) since the effective plate voltage on a tube is measured between plate and cathode, raising the cathode to a positive potential, as is done with cathode-biasing, reduces the effective plate voltage on the tube by the amount of the bias voltage. This last disadvantage becomes important in A.C.-D.C. sets, where plate-voltage is low, and in sets using power triodes, such as the 2A3, where the required bias is very high.

As to the first trouble, stability (i.e., voltage regulation) of the bias voltage is of utmost importance, and, for good ef-

iciency, a 1% variation should never be exceeded. Looking at the cathode-biased stage, we see that such regulation is impossible. Some experimenters connect hundreds of microfarads across the cathode, and this no doubt helps. But it cannot eliminate the fact that the bias voltage developed by this

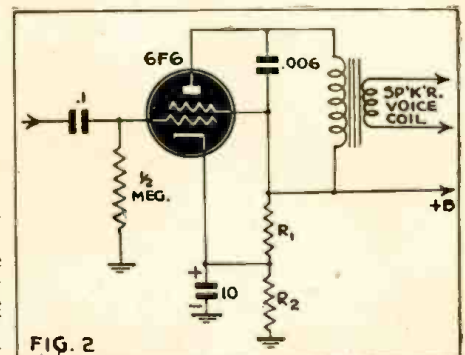

FIG. 2

An attempt to avoid some of the consequences of cathode biasing.

method is to some extent dependent on the varying conditions inside the tube, no matter how big a condenser is used. Besides, why waste money buying huge capacities?

Our primary aim, then, is to make the bias voltage completely independent of the tube to be biased. This is the primary feature of fixed bias. One way to do this is to connect the cathode of the 6F6 output tube of Fig. 1 to a point on a bleeder across the B+ supply (Fig. 2). One can see that through R2 we have two current components—the cathode current and the bleeder current. The cathode current is subject to the same variations as before but the bleeder current (assuming a decent power supply) is constant.

We can achieve only a small part of our aim with this set-up. We have failed to make the plate-cathode potential equal to the plate-ground potential, and (unless we have used outrageous values of bleeder current) we have only about 50% freed the voltage from dependency on the varying cathode current.

To get true fixed bias we must begin by grounding the cathode and look elsewhere for a negative voltage which we may apply at the low end of the grid return. Here we see that the class A1 amplifier presents a much simpler problem than the class AB2

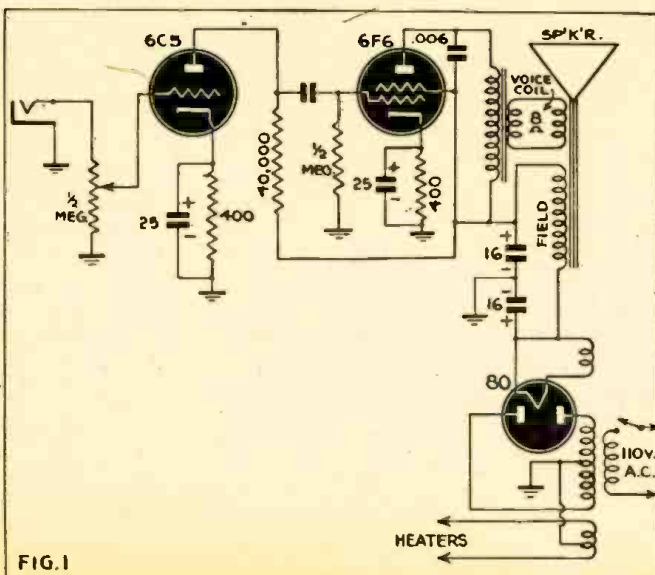

FIG. 1

The old standard audio amplifier. Changes in grid-bias at an audio rate, caused by varying current through the cathode resistor, put a definite limit on the amount of power this unit will handle without serious distortion.

# AMPLIFIERS

## -Fewer Tubes

EDMONDS, JR.

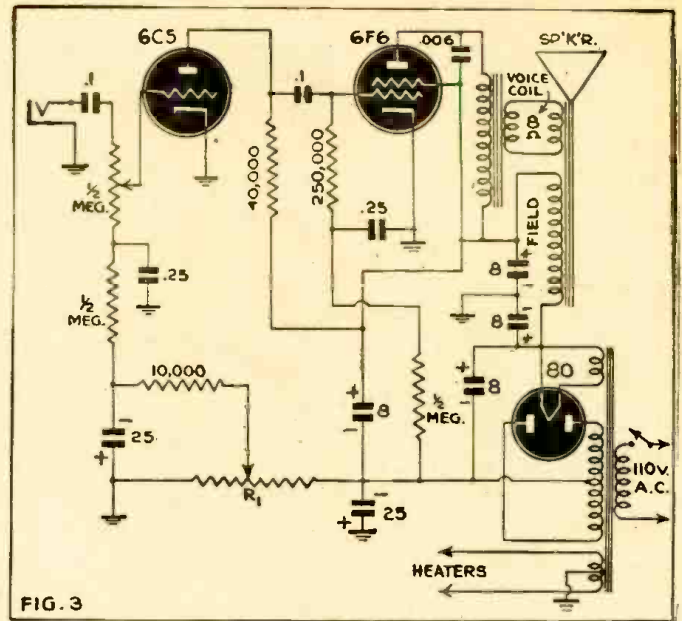

FIG. 3

An approach (not entirely successful) is made to true fixed bias in the circuit at the right.

or B modulator, chief figure in the nightmare aroused in most experimenters' minds by the mention of fixed bias. First, the class A1 amplifier *never draws grid current*. This is our prize postulate in dealing with fixed bias for small tetrodes and pentodes, for see what it allows us to do: We may put practically any combination or value of resistors we like in the grid return, and not worry about voltage drops, since (excepting by-pass condenser leakage) there is never any current whatsoever (under proper circuit conditions) flowing in anything in series with the grid of a class A1 stage.

Second, the ordinary receiving type power tube has no critical grid impedance, and so we may forget about that. All we have to do is to unground the grid return of our 6F6 in the circuit of Fig. 1 (or of any other tube in a similar application—the 6F6 is here used merely as an example) and apply the right bias from the simplest source we find handy—anything that gives 22.5 volts and is stable. Some tubes, like the 6V6, have a fairly low maximum permissible grid resistance. The solution to this problem is merely to use transformer coupling.

### AN OLD-TIME SYSTEM

One of the most widely used methods of biasing is the type using a resistor in the negative return of the power supply. It is the one found in 90% of the commercial A.C. sets. In this type, a resistor is inserted between the power transformer's high voltage secondary centertap and ground. The entire B+ current must pass through the resistor in such a direction that a voltage, negative with respect to ground, builds up across the resistor. By using the correct resistance value, the correct voltage for biasing the output stage may be obtained. Fig. 3 shows the circuit of Fig. 1 adapted for this biasing system. The value of R1 may be determined as follows by applying Ohm's Law: If I<sub>t</sub> represents the total current drawn from the power supply (including current drawn by any bleeders which some circuit other than that of Fig. 4 may use), then, for a 6F6 in class A1 (22.5 volts bias):

$$R1 = \frac{22.5}{I_t}$$

The tap may be adjusted to the correct point (8 volts for a 6C5) on R1 by means of a voltmeter connected from the tap to ground (ground positive). Be sure not to

attempt to measure the bias voltage at any other point than right on the hot end of R1 (for the 6F6 bias voltage) or right on the tap (for the 6C5 bias voltage) for if you try measuring it at the grids or after the decoupling resistors with anything but an electronic voltmeter, the current drawn by the meter will cause an appreciable voltage drop through the resistors in the circuit (decoupling and grid resistors).

This circuit is still far from true fixed bias. The drop across R1 prevents the full voltage output of the power supply from being effective as "B" voltage, and the current through R1 is not steady. We have only succeeded in moving the second disadvantage of ordinary cathode bias to another part of the circuit and in reducing but not eliminating the first disadvantage.

This circuit works best in a large amplifier or radio where a number of tubes and perhaps a high-current bleeder draw current through the bias resistor. Since the plate current variations in one stage are 180 degrees out of phase with the variations in the next, the average bias current in such sets may be fairly close to constant. Another disadvantage is a greater tendency toward hum, which requires a series of de-

coupling resistor-condenser networks, to prevent the hum from reaching the grids of the audio tubes. Extra filtering is also required—note the two pairs of filter condensers in Fig. 4. Low supply voltage and additional difficulty in filtering the output of a half-wave rectifier make the system entirely impractical for A.C.-D.C. sets. It is cheaper to use two tubes in push-pull with cathode bias than to buy the condensers and find the extra chassis space required to bias a single tube by this method.

### A PRACTICAL AMPLIFIER

The commercial A.C. set designers have several tricks that the experimenter might well profit by to help him overcome the disadvantages while retaining all the advantages of this system of fixed bias. Fig. 4 shows the circuit of an audio system closely paralleling that of a G.E. set. The circuit was noted down while the set was in the author's shop for servicing because of the efficient way in which the type 41 operated and the neatness with which most of the undesirable features of the bias supply system just described were overcome. The main feature of the circuit is the substitu-

(Continued on page 754)

Using the necessary voltage drop across the speaker field coil to supply negative bias voltage make this a more efficient circuit than that of Fig. 3. Fair power levels may be attained with this hookup.

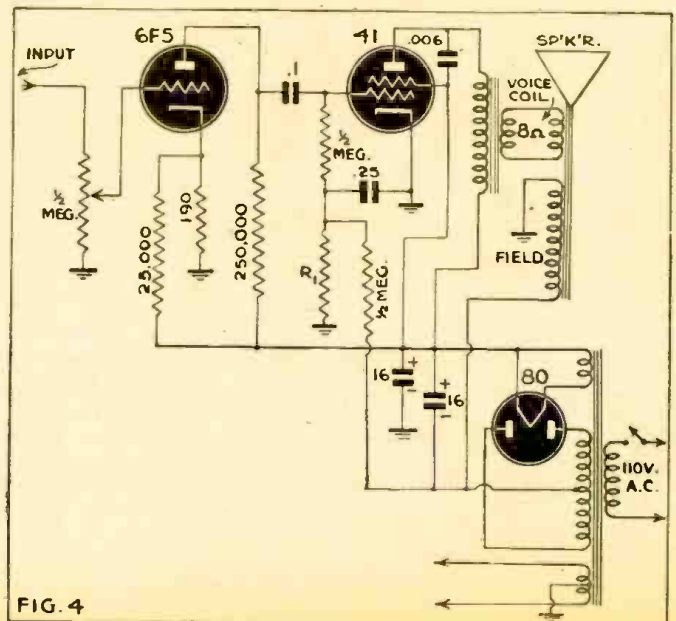

FIG. 4

# PICK-UP PERFORMANCE

## PART I

By TED POWELL (Associate, I.R.E.)

**T**HE most obvious factor affecting the play-back performance of any phono assembly is the mechanical alignment of the pick-up and turntable.

If the turntable height is too great for the pick-up arm, the pick-up stylus mechanism cartridge will not be parallel to the record disc and the needle slant will be too great. As the result, the underside of the needle will ride the advancing side walls of the oncoming modulation grooves. It will ride in the centers of the modulation troughs only at about the maximum swing of the grooves

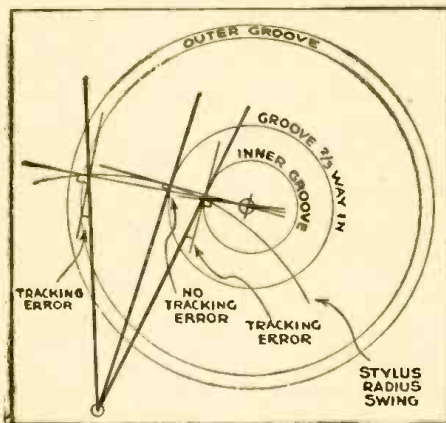

Fig. 1a—Tracking error when a short pick-up arm is used.

since it is tangent to the modulation waves at these points. This exaggerated "skating" or "tobogganing" will result in wave-form distortion—especially at the higher audio frequencies—since there are more modulation waves per inch, greater curve slope and therefore greater tobogganing effect.

If the turntable height is not great enough, needle slant is too small. While less skating and superior tracking results, needle scratch and record groove wear will be increased. The tracking is better, since the stylus shaft is free of the groove walls. The increased stylus hiss and record wear are caused by the near-perpendicular position of the stylus shaft which results in greater shear stress effect on the record plastic. Besides, stylus tip contact area is smaller and stylus pres-

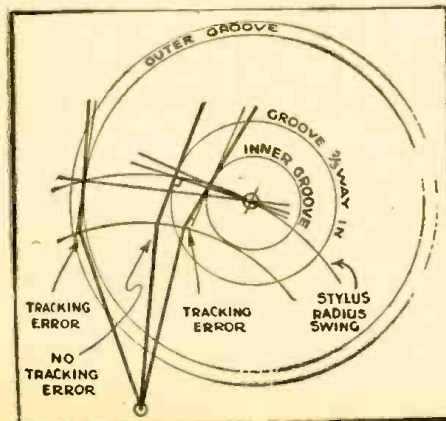

Fig. 1b—The action of an offset pickup head in reducing tracking error.

sure is greater. This is especially true where low-priced heavy-pressure pick-ups are concerned.

### PICK-UP HEAD ALIGNMENT

Perhaps the most serious and most common tracking error encountered in phono work is due to the failure of the pick-up head to maintain exact tangency to the record grooves over the useful radius swing of the pick-up arm because of the simple geometry involved. If a pick-up with an arm 12 to 16 inches long is used on average sized recordings, the tracking error is not very great, if a good compromise location is selected for the pick-up pivot base. When a shorter arm unit is used, considerable tracking error will occur over the two extremes of the useful radius swing of the arm, especially when the stylus is riding the innermost grooves on the recording disc.

At a point near the middle of the record groove area, there is exact pick-up head tangency to the modulation grooves. As the pick-up arm gradually swings to a position where its stylus cartridge longitudinal axis is no longer tangent to the record grooves, the needle swing is no longer parallel to the axis of the modulation waves and they are unsymmetrically distorted as far as the stylus mechanism is concerned. Skating is also exaggerated.

This tangency tracking error can be minimized by using a pick-up with a stylus head off-set about 30 degrees or so. A medium-sized arm with a tangent off-set head used on a standard-sized recording will result in only about one or two degrees of tracking error. When a longer arm of about 12 or 14 inches is used with such a head, the tracking error is negligible. See Fig. 1 (a) and (b).

### THE INSIDE OF THE BEND

When a pick-up assembly is being mounted and manufacturer's specs are not available, a compromise spot for the pick-up base should be so chosen as to prevent excessive divergence from stylus cartridge tangency over either extreme of the arm's radius swing over a large record disc. Furthermore, tangency should be favored at the inner record grooves since the radius bend of these inner grooves is greater and the diameter is smaller.

Two detrimental effects take place simultaneously. The increasing groove curvature and decreasing diameter result in an increasing divergence from tangency because of the simple geometry involved. Furthermore, since the groove velocity gradually decreases, more and more modulation waves per inch are required for a given frequency signal. The modulation wave curvature slope is therefore steeper and tangency tracking error and stylus, skating is still further exaggerated. Roughly speaking, a compromise spot should be so chosen for the arm pivot base so that exact tangency occurs at about two thirds the way in from the outermost modulation grooves.

Incidentally, by drawing a hair-line mark down the pick-up head's long axis and then securing a thin straight-edge to the top of the head at right angles to this center-line and directly over the stylus tip with some scotch tape or sticking plaster, the optimum spot for the pick-up base can be found more

readily. When this thin straight-edge passes through the t.t. center-pin, exact tangency exists.

Another simple mechanical tracking error will result if the t.t. is set at a side pitch with respect to the pick-up arm or if the pick-up arm is set at a side tilt. The needle swing is no longer centered with respect to the modulation groove, the pick-up head will tend to vibrate or "walk" up and down, and the under side of the tilted needle will tend to climb the groove wall ridges on the

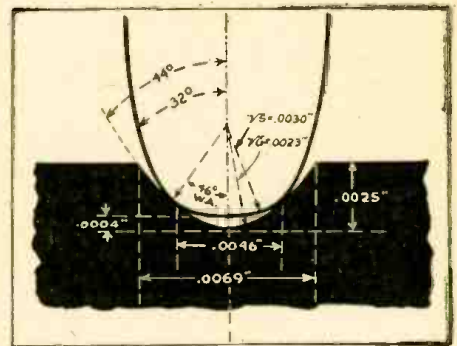

Fig. 2—Compromise specifications for stylus and groove (after Beers and Sinnet)  
Stylus pressure—12 grams approximately  
Groove Depth—.0025 inch  
Angle between groove walls—88 degrees  
Groove through radius curvature—.0023  
Stylus tip taper angle—64 degrees  
Stylus tip radius—.0030 inch  
Stylus-in-groove wedging angle—46 degrees  
Stylus-in-groove tracking diameter—.0046 inch  
Clearance between bottom of groove trough and stylus tip—.0004 inch approx.

side towards which it is tilted. Thus both skating and unbalance stylus mechanism swing combine to produce wave-form distortion which will chiefly consist of even-order harmonic and even-order harmonic cross-modulation distortion.

### LESSER KNOWN DISTORTION EFFECTS

Sometimes amateurs cut their recordings with a modulation groove with too great an amplitude swing. Two distortion effects present themselves when such an over-cut recording is played back.

In the first place, a pick-up unit is an electro-mechanical transducer much the same as a microphone or a speaker and if overloaded, will develop various types of distortion, especially harmonic, harmonic cross-modulation and the lesser-known frequency-modulation distortion.

The other distortion factor concerns the recording itself. When a recording is cut with modulation waves with an excessive amplitude swing, the groove side walls become too thin at the peaks of the waves since these peaks approach too closely to the adjacent groove modulation peaks. The groove walls are weakened and their elastance flex increased under the impact of the stylus and the impedance of its drive mechanism. The peaks of the waves are exaggerated more or less as the over-thin groove walls flex at these points, and wave-form distortion is the result.

(Continued on page 757)

# OHMMETERS ARE HANDY

*The new Trainee or beginning Serviceman often finds that, next to getting instruments to work with, his greatest difficulty is in using them intelligently. Jack King has a few pointers for him.*

By JACK KING

**T**HE serviceman who must make rapid and accurate tests efficiently finds the ohmmeter his most useful instrument. The purpose of this article is to explain the practical use of this instrument to the Radio Trainee and the beginner in radio servicing.

To make the measurements it is necessary to have on hand an accurate tester which has a range, in suitable steps, from as low as .05 ohm to as high as 20 megohms. This is a necessity for modern servicing operations.

It is needless to point out, in the interests of safety and the prevention of damage to the meter, the radio should be entirely disconnected from the power line when using an ohmmeter.

## TESTS ON A TYPICAL RECEIVER

We can make the explanation clearer by using a typical receiver, the Stewart Warner R-111, for analysis. This set is shown in Fig. 1. The chassis is not grounded directly, so in testing we do not put the ohmmeter between the rectifier cathode and ground but connect it between the rectifier cathode and the on-off switch, with the switch turned to the on position. This is the extreme negative point in this set. If we find the resistance very low, less than 2,000 ohms, we would certainly suspect a short circuited filter condenser or a short in some other circuit part connected across the cathode (B+) and the on-off switch (B-).

The resistance measurement for the output of the rectifier takes two separate tests in this set since cathodes of the 25Z5 are not connected together. One goes to the speaker field and the other goes to the filter condensers marked 34, 14C and 14B. The resistance measured from the positive side

(cathode of rectifier) of filter 34 to the on-off switch should be quite high, above 100,000 ohms in some cases. With speaker field 18 disconnected from the circuit the reading across the terminals of C14A would be high, also probably above 100,000 ohms. The resistance with the field in circuit may be less than 3,000 ohms, but generally not below 1500 ohms.

This shows the importance of taking shunt paths into account when making resistance measurements.

The ohmmeter test across C14A is a check on whether the speaker field is open, but is not a good test of the condition of Condenser C14A. To check the condenser we can disconnect one lead and apply an ohmmeter. Before doing this, the condenser is shorted to remove any stored electric charge which could kick over the pointer. The ohmmeter is then applied. The instrument should be set to read resistances as high as 2 megohms. The red lead is connected to the condenser's negative, and the black to the positive terminal. As the meter is applied the pointer swings up, indicating charge, and then gradually recedes toward zero. A good electrolytic condenser may have a leakage resistance of over 100,000 ohms and in some cases as high as 1 or 2 megohms. The exact values will depend on the quality of the condenser, its age, and its capacitance value, the larger condensers generally having higher leakage and lower resistance.

## A CAPACITY METER, TOO?

The relative amount of the meter pointer's kick during the charging operation, enables the expert serviceman to estimate pretty accurately the condition of the condenser and to decide whether its capacity is approximately normal. If the condenser

is open, hum, distortion or both may be in evidence in the set.

Though the filter condensers are frequently the cause of distortion, not the least important element—often the most important—is the grid condenser. This unit is marked 15 in the diagram, and is connected to the grid of the 43 output tube. To check 15 one lead is disconnected and an ohmmeter is placed across the condenser's terminals. If the condenser is acceptably good its leakage resistance should be above 20 megohms. The higher the better, but 20 megohms is the lowest acceptable limit. Otherwise distortion may be produced due to leakage current through the condenser to the grid of the output tube.

## CHECKING OUTPUT TRANSFORMER

There is a simple way of checking the condition of the primary of the output transformer. Put one prod on the plate of the 43 and the other on the screen. The resistance may range from 100 to 300 ohms, depending on the type of radio and the sort of output transformer employed. Any much higher value of resistance shows that something is likely to be wrong, and so does any greatly lower value.

Leakage between the primary and the secondary of an output transformer, in the writer's practical servicing experience, has been very rare; still, it can occur. To check for leakage between the primary and the secondary of part number 12 on the diagram, disconnect the transformer from the plate and screen of the 43. Then put one prod of the ohmmeter on the primary, connecting the meter to either the plate or the screen lead, it doesn't matter which one is used, and put the other prod on one of the voice coil terminals. The leakage resist-

*(Continued on page 747)*

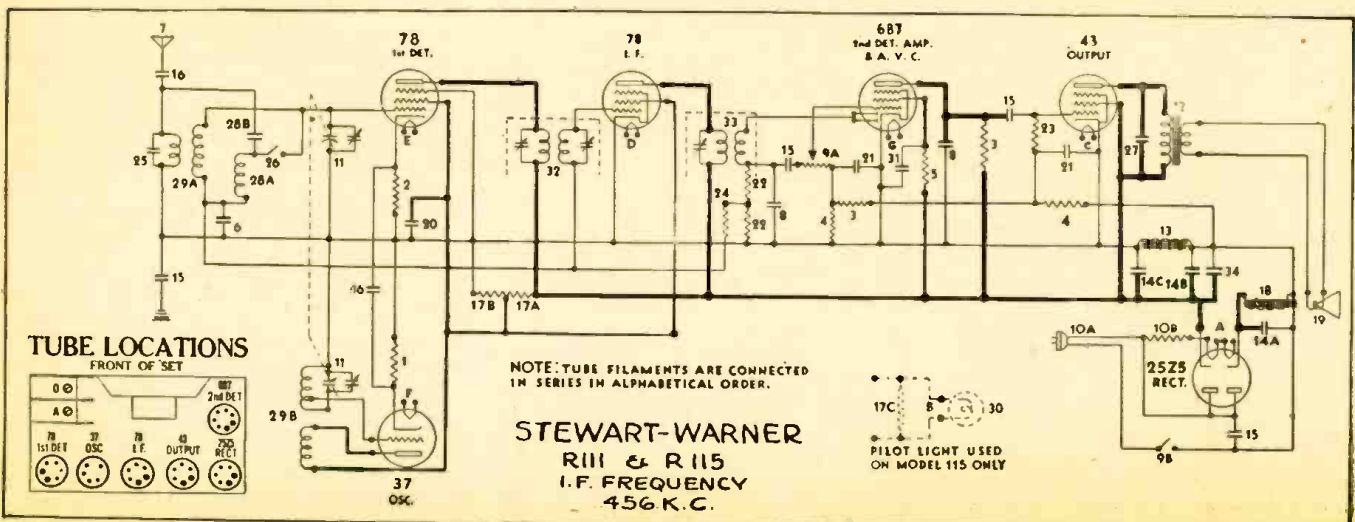

# CAPACITESTER

## For Dynamic Checks

By ROY R. MAXSON

**A** FEW years ago while operating a service shop, I needed to obtain a condenser checker which would test the quality of a condenser while connected in the circuit. At that time no such unit was available on the market. While owning one of the best commercial condenser testers, nevertheless I had to remove one side of the questionable condenser from the circuit in which it was employed to determine if it were open or had developed contact resistance.

The condenser quality tested described in this article is the result of considerable experiment and design and it has the following advantages: (1) Checks the quality of the condenser while connected in the circuit. (2) Positive indication with no charts or figuring. (3) Ease of operation using ordinary test prods, no shielded wires or awkward terminal connections. (4) Provision to test resistance or voltage across the condenser, simultaneously with the quality test. (5) A locking circuit which could be used in cases where the tester had to remain across a suspected condenser for a period of time and would give a positive indication without the necessity of the operator constantly watching the indicator. (6) Low cost, easy construction and economical operation.

### CHOICE OF CIRCUIT

The circuit decided upon consists of a 76 oscillator, link coupled to a tuned circuit, both operating at eighteen hundred kilocycles. The link circuit is broken on one side and brought out to pin tip jacks. The tuned circuit is connected to a 6B7 pentode section. The output of the pentode section is rectified in the diode section and the negative potential developed is applied to the grid of a 6E5 tuning indicator tube.

Since the link circuit is carrying radio frequency at low potential, any resistance or reactance in series with it will lower the energy transfer from the oscillator to the tuned circuit. The frequency chosen, 1800 kilocycles, will encounter a reactance of approximately 10 ohms when applied in series with a .01 mfd. condenser. Most condensers used in radios and associated circuits have capacities greater than this. It follows that their reactance will be less. Since the values of resistances used in radios are generally 200 ohms or greater, if a .01 mfd. condenser is placed across a 200 ohm resistor and this combination tested by this instrument, taking the energy transfer to represent 100 per cent, it will be found that 95 per cent passes through the resistor. Therefore if the condenser

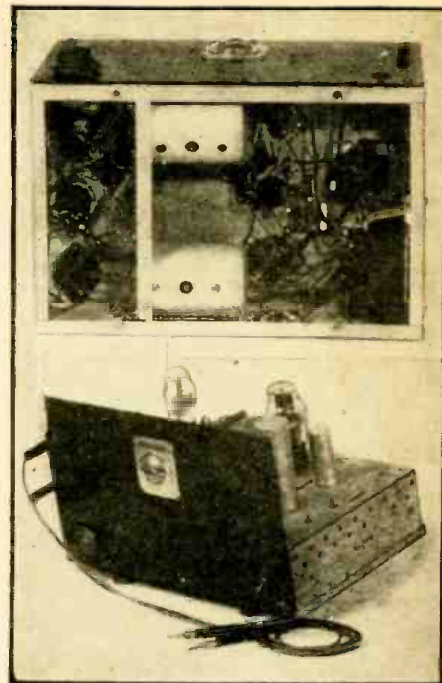

Two views of the Capacitester as constructed by Mr. Maxson. The instrument is simple and not hard to construct.

should open circuit there will be a loss of 95 per cent of the energy transfer in the link circuit.

In a case where the resistance is developed internally in the condenser (contact resistance as it is generally called) the energy transference loss will be governed by the voltage drop across this resistance. It can readily be seen that the resistance or reactance connected across the condenser is so much higher than the reactance of the condenser itself, that it may for all practical purposes be disregarded. Any internal resistance or contact resistance in the condenser itself will reduce the energy transfer in direct proportion to the amount of resistance developed.

The locking part of the circuit is as follows. The negative bias used to close the 6E5 tube's shadow is also applied to the grid of a 6F5 used as the locking tube. Its plate is connected through a toggle switch to one side of the secondary of a three to one ratio, audio transformer. The primary of the transformer is connected to the A.C. line connections across the regular power transformer. The ground return of the secondary goes through a 500,000 ohm resistor.

It takes approximately eight volts negative bias to completely close the shadow on the 6E5 magic eye tube and this same voltage is applied to the grid of the 6F5. Due to the tube's high mutual conductance it is biased to plate current cutoff. However, if there is any failure of the energy transfer link circuit caused by the condenser under test opening or the circuit being opened in any way, there is no longer any radio frequency flowing through the circuit. The result is with no radio frequency to amplify and rectify in the tuned circuit, the grid bias falls to zero potential on both the indicator and locking tube grids, the indicator tube's shadow opens wide and the locking tube passes plate current the negative component of which is applied to the grid of the 6B7 pentode section stopping it from amplifying any further even if the energy transfer link circuit should be closed again. Therefore the indicator tube's shadow remains locked open until the switch in the

(Continued on page 748)

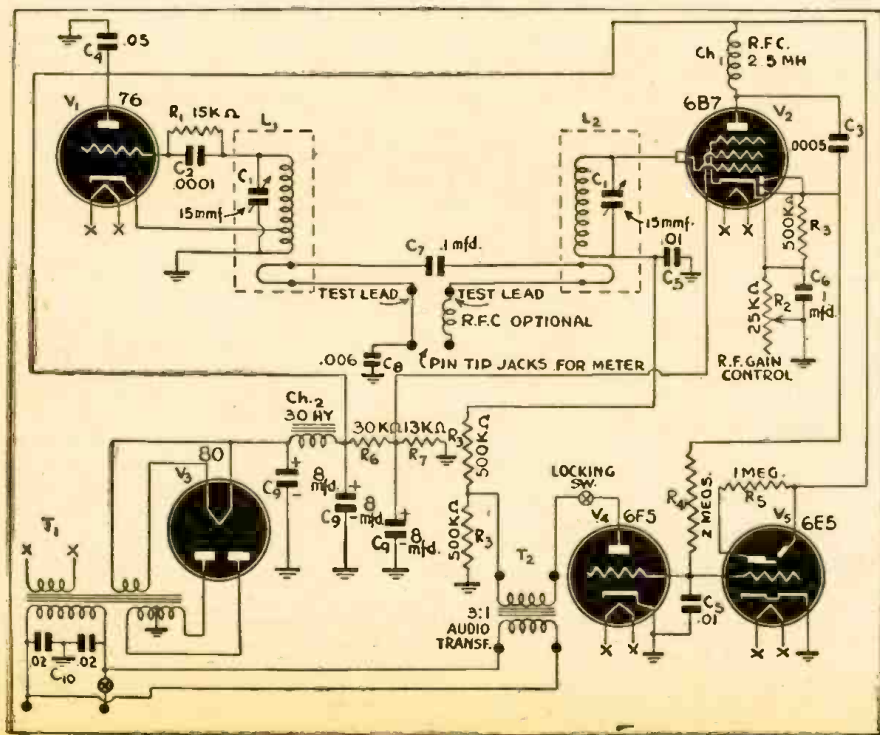



# "FALCON-4"

*The attractive little receiver at the right is a real war product, representing the experience of people faced with four years of shortages, struggle and threats of invasion. Its design and construction embody several features particularly interesting to American constructors.*

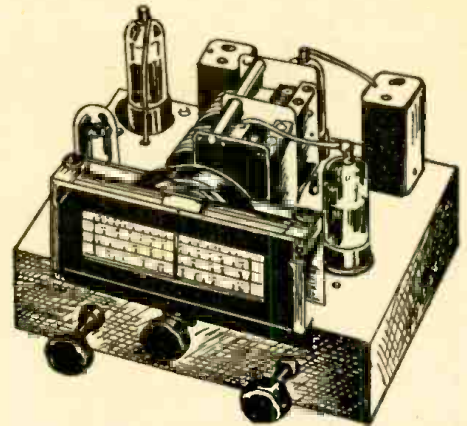

**T**HE American experimenter can learn much from his European and Australasian colleagues, who have been at war for four years. From Australia comes this four-tube dual-wave receiver, a set designed with the sole aim of reducing battery drain.

We imagine that we are facing a scarcity, but the average Aussie thinks of us as sitting in clover. Batteries have been off sale for years in that country, and the radio magazines carry articles on "rolling your own." Tubes cannot be obtained by the expedient of turning in old ones. They just don't exist. If one is needed to complete a layout, the would-be constructor advertises for it in the radio press, sometimes offering to swap some "unobtainable" component of his own for the desired type.

Thus an Australian set will be found to have the minimum in hard-to-get parts and fancy frills. Design is as simple as it could be made, and components used are the fewest possible. The result is an attractive, easy-to-build receiver, the result of the experience of men who can still "put 'em together" after four years of war.—*Editor*

Most notable advance in battery tube technique during the past few years, the new 1.4-volt tubes represent an important step forward towards the ideal in battery receiver design. Years ago 6 and 4-volt filaments gave way to 2-volt, and now designers have available a highly successful series of tubes requiring only 1.4 volts across the filaments.

More important still, filament current has decreased in proportion, so that it is now possible to design a 4-tube receiver drawing a total filament current equal to that taken by a single tube several years ago, and with a total filament wattage only a fraction of that used in radios manufactured a few years ago.

## "B" CONSUMPTION IMPROVED

An equivalent advance has also been made on the "B" supply side. Receivers drawing up to 20 or 24 mils. "B" current at 135 volts were the order of the day a few years ago. Today, corresponding performance can be obtained from a set drawing only 10 to 12 mils at 90 volts.

While this remarkable improvement in economy is largely due to advances made in tube design, part of the credit must also go to the new type permanent magnet speakers. Sensitivity has been increased considerably, or in other words, using a latest type permanent magnet dynamic speaker, considerably more volume is obtainable with a given output than from an equivalent type speaker of several years ago.

## "FALCON DUAL-WAVE FOUR"

The "Falcon Dual-Wave Four" illustrated above is an example of what can be

achieved with the new 1.4-volt tubes, high-gain coils and latest high-sensitivity speaker. A four-tube dual-wave receiver drawing .25 ampere "A" current at 1.4 volts, and approximately 10 mils "B" current at 90 volts, it gives a performance comparable with that of earlier receivers with approximately double the "A" and "B" wattage.

## USES READY-WOUND COIL UNIT

The receiver uses a recent dual-wave coil unit and a pair of high-gain I.F. transformers, (either air or iron-core types may be used). A 1A7G is used as mixer-oscillator, and while this tube was designed primarily for broadcast operation, it works splendidly on the short waves as well.

Next follows one of the 1P5-GT multi-tube pentodes as I.F. amplifier, followed by a 1H5-G as diode detector and triode audio amplifier driving a 1Q5-G beam output pentode. This tube has characteristics broadly resembling those of the 1C5-G, but it operates with considerably less grid bias, and is therefore more sensitive. For those particularly interested in "B" economy, the 1Q5-G has a further important advantage, in that it may be operated satisfactorily under over-biased conditions, giving an appreciable reduction in "B" battery drain without serious increase in distortion.

The 1Q5-G has a 1.4-volt filament drawing .1 ampere. With 90 volts on both plate and screen, and a bias voltage of -4.5, the plate and screen currents are 9.15 and 1.6 mls, respectively. Load resistance is 8,000 ohms, total harmonic distortion 7.5%, power output .27 watt.

More than ample volume for domestic requirements can be obtained by using a good speaker with at least a six-inch cone. Constructors prepared to pay more can obtain even greater output with an 8- or 10-inch speaker of high sensitivity.

The circuit of the "Falcon Dual-Wave Four" is perhaps the simplest possible that

could be developed while still incorporating every worthwhile modern feature. A simple and effective a.v.c. system has been included, operating on the 1A7-G and the 1P5-G. A fixed tone control, consisting of a .005 mfd. condenser from the plate to screen of the 1Q5-G has been included, though it would be a simple matter to incorporate a variable control if desired. However, as reproduction is very well balanced, the fixed control is actually all that is necessary.

A list of parts required for the receiver is given in this article, and together with the illustrations, will enable those experienced in set building to complete the receiver without further assistance.

## List of Parts

- 1 aluminum or steel chassis stamped and drilled as shown
- 1 dual-wave coil unit
- 1 iron-core i.f. transformers
- 1 2-gang condenser
- 1 50,000 ohm potentiometer, with switch
- 4 octal, 1 6-pin, 1 4-pin sockets
- 3 knobs
- 1 slide rule type dial
- 2 terminals, 1 red, 1 black
- 1 6-wire battery cable
- 1 4-pin speaker plug, 1 6-pin battery plug

## FIXED RESISTORS

- 2 .1 megohm carbon
- 1 .2 megohm carbon
- 3 .1 megohm carbon
- 3 1 megohm carbon

## FIXED CONDENSERS

- 2 .0001 mfd. fixed
- 1 .0005 mfd. fixed
- 1 .005 mfd. fixed
- 3 .05 mfd. tubular
- 2 .1 mfd. tubular

## TUBES

- 1 1A7G, 1 1P5G, 1 1H5G, 1 1Q5G

## SPEAKER

- 1 8 inch permanent magnet dynamic speaker, input transformer to match single 1Q5G

## BATTERIES

- 1 1.5-volt "A" unit
- 2 45-volt "B" units
- 1 4½-volt "C" battery

## MISCELLANEOUS

- 3 grid clips, solder lugs, nuts and bolts, hook-up wire

—The Australasian Radio World.

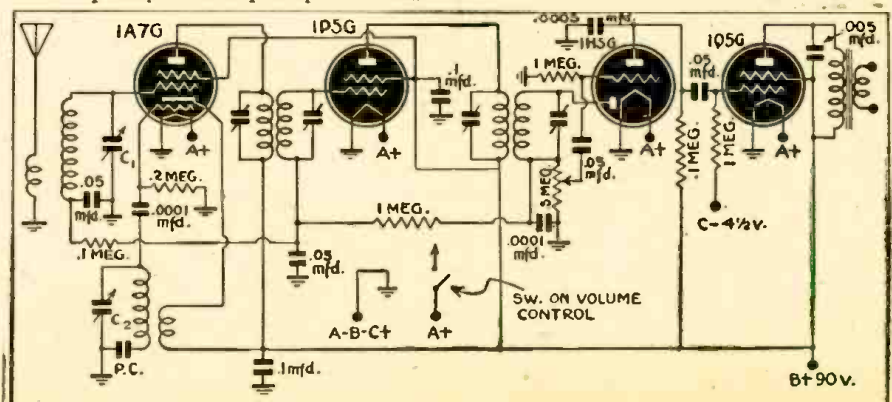

The Falcon-4, a thoroughly standard design. No ideas which would call for extra parts are presented. Economy of battery consumption is the keynote.

# BARB-WIRE TELEPHONE

By FRED H. RANDOLPH

WE call our telephone a "Broadcasting Line." I don't know where the name started—probably some of the neighbors called it that on account of all the radio apparatus in it. It works from my place to one about 3 miles away, with one line of iron fence wire. The return circuit is ground.

It is not a "carrier communicator." We simply use the little two-tube amplifiers to give us a good signal, and so we can use speakers instead of headphones for listening. This makes it simpler. When I want to make a call, I go to the desk, push down two toggle switches and say, "Oh Charley, are you there? I want to ask you something." If Charley is anywhere near the house, he comes, or his wife. It works the same as a telephone system, with speakers instead of bells—and you don't have to say, "What? Huh?" If you have the headset on and the volume at "full," when he answers you will have broken eardrums.

I don't deny that this probably could have been made better or more efficiently. Most of the commercial interphones use the speaker as a microphone. We had carbon mikes and used them. These were the regular telephone transmitter type and worked better than a ten-dollar carbon mike tested later. Our mikes will stand up to 6 volts and give extra strong signals with less trouble from feedback.

The mike feeds into an ordinary modulation transformer, or "telephone coil." The transformer has a 250,000-ohm potentiometer across its secondary, to act as a volume control. This can be turned up or down according to instructions from the other end.

The first amplifier tube is a 32. You must have a screen dropping resistor that will cut the screen voltage down to half the plate voltage, or the tube will not work well. We use ordinary 3 to 1 audio trans-

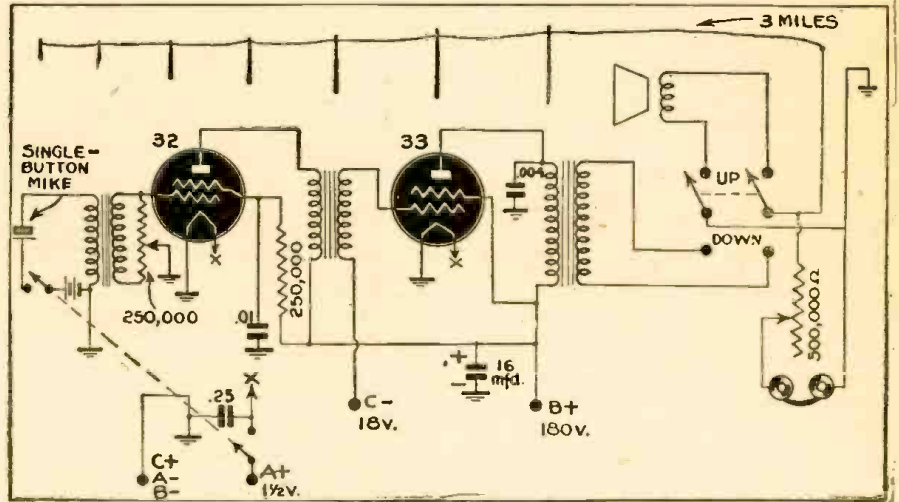

Schematic of the amplified line barbed-wire line telephone. Here is a circuit built from parts at hand and engineered by cut-and-try to do a definite and specific job.

formers to couple to the 33's, and believe it or not, they work O.K.

The 33 works with -18 volts C battery. You can get good service with -16 volts "C" and 135 volts on the plate, but when battery supplies are normal, the 180 volts is more satisfactory.

The .004 condenser from the 33 plate to ground acts as a sort of tone control and permits the tube to work smoother. Sometimes you get oscillation in this stage without it. The output transformer is a 1 to 1, and when you push the switch down, you connect the speaker at the other end of the line to your amplifier. There seems to be very little loss on the line—at least we get all kinds of volume—even though an engineer might go crazy trying to fig-

ure out the matching, with our single wire and ground return.

All of this apparatus can be put into one cabinet. Throwing both toggle switches UP, cuts you and your power off and leaves the line set for a call at anytime from the other station. This line has volume enough to hear all over the house and way out in the yard.

Throwing both switches DOWN puts you and your power on the line, and the other station (run on the same rules) will hear you call.

All the grounds shown are "to chassis" with the exception of the one on the secondary of the output transformers. These are outside grounds, and should be good, especially in dry seasons.

# RADIO CHECKER FOR WARTIME

By R. E. CRAGO

FIND that by using the neon checker as a continuity or condenser tester, much faster work can be done by adding a small magnetic loudspeaker to the apparatus, as I can then check by tone without having to look at the neon bulb.

The tester can be made very attractive looking by securing a black crackle finish metal box (if unavailable, one made of plywood, stained and varnished, should do nicely). It should have a hole 1 25/32 inch cut in one side to permit the neon bulb to protrude. A hole on the opposite panel should be cut and a heavy piece of screen cemented on the inside to protect the speaker grill from possible damage. The size of the hole of course depends on the speaker available. The neon tube now is in the front panel and the speaker is at the back. Although the speaker is not a necessary part of the tester, I find that it really does make up for the slight time required to mount it!

The circuit is clearly shown in the diagram. It is an ordinary neon tester. The 25-watt lamp is used as a dropping resistor to control filament current to the tube in-

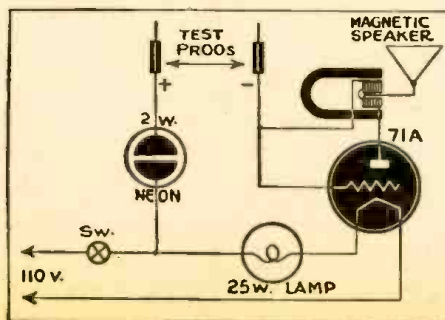

serted in the circuit to supply tone to the speaker. I used a 71A—almost any triode or pentode, would work here. The triode may be hooked up as a straight rectifier, with plate and grid tied together. I prefer the circuit shown in the diagram.

A loud, clear signal from the speaker and a bright glow from the neon lamp tells you when a shorted condenser is found. Good condensers show up with a combination blink and a raw alternating current sound from the speaker. Used as a continuity tester, it will be found that different values of resistance in circuit give different tones, making it possible to make a rough check much faster than by paying attention to the neon bulb alone.

The Serviceman has more work than he can do these days, and any instrument that can speed it up a little is worth while. This tester is also useful to the man who cannot obtain meters with which to build more exact types of instruments.

# THE LISTENING POST

Edited by ELMER R. FULLER

**P**ROBABLY the best catch of the present time is the new transmitter now being used by FZI, "Radio Brazzaville," and located in French Equatorial Africa. It is under the control of the Allied Nations through the Fighting French under General Charles de Gaulle. When first heard, only three thousand watts were used. Now a fifty kilowatt American-made transmitter has been installed. New antennae have also been erected. The frequency used is 11.970 megacycles; transmissions being made during the afternoon and evening. A news broadcast in English is broadcast daily at 7:45 to 8 pm, E.W.T. The program opens with the French National Anthem, and closes with the Star Spangled Banner. Quite often the announcer is a woman. Reception of this station is very good, and regular, with a fadeout as darkness approaches the listener.

The National Broadcasting Company, International Division, broadcasts during a total of 18 hours daily in nine languages—English, Spanish, Portuguese, Italian, German, French, Danish, Swedish, and Turkish. The Spanish and Portuguese language programs are beamed to South America; while the remainder are directed towards Europe and Africa. Broadcasts in English, Spanish, and Portuguese will be found in our station lists. Transmissions in other languages are as follows:—

- Italian:** 2:15 to 2:45 pm—WRCA-WNBI  
5:45 to 6:15 pm—WNBI-WKRD  
12:45 to 1:00 am—WKRD-WLWO-WCRC-WKTS-WKLI
- German:** 8:15 to 8:30 am—WGEA-WKRD  
1:30 to 2:15 pm—WRCA-WNBI  
4:30 to 5:15 pm—WRCA-WNBI
- French:** 6:45 to 7:00 am—WRCA-WNBI-WKRX  
12:45 to 1:15 pm—WRCA-WNBI  
2:45 to 3:15 pm—WNBI  
3:45 to 4:15 pm—WNBI-WRCA

- Danish:** 12:15 to 12:30 pm—WGEO  
3:15 to 3:30 pm—WGEA
- Swedish:** 12:30 to 12:45 pm—WGEO
- Turkish:** 2:15 to 2:30 pm—WCRC-WCBX

It is anticipated that in the weeks to come program material from the Southern European Front will be available in recorded form in London. It is planned to place this material when it is so available in the North American Service from 7:45 to 8 pm, on the evening of its reception in London. This will be heard on several of the BBC transmitters now being used nightly in the North American Service, and will be of interest to us.

A major change in American propaganda policy seems to be in the offing. It has been disclosed that a number of powerful stations will be built throughout the world. The Crosley Corporation of Cincinnati has been authorized to install new transmitters with a total power of 750,000 watts. These will be built near the other transmitters of the company.

According to Don Francisco, director of radio for the Office of Coordinator of Inter-American Affairs which supervises all broadcasting to Latin America, plans have been completed for simultaneous Spanish programming of ten short wave transmitters. Five of these were formerly served by NBC and five by CBS. The stations carrying these programs are WCDA, WRUS, WRUW, WRUL, WCRC, WLWK, WLWO, WNBI, WBOS, and WGEO.

Yours truly recently heard W6XPW, Los Angeles, California; owned and operated by Press-Wireless, Inc., broadcasting news at 8 pm. Frequency used was 12.0 megacycles. The signals were very weak, but were understandable through the QRM of nearby C.W. stations.

Evening news broadcasts in English are being aired as follows:—

- 6:45 pm London GSD 11.75  
GRG 11.68
- 6:47 pm Moscow — 9.48, 15.23
- 7:00 pm Berlin DJD 11.77
- 7:00 pm Spain EAQ 9.86
- 7:45 pm Brazzaville FZI 11.97
- 8:00 pm Moscow — 11.947
- 8:30 pm Rome 2RO3 9.63  
2RO22 11.94
- 9:00 pm Berlin DJD 11.77
- 9:00 pm Mexico City XERQ 9.615
- 9:00 pm Tokyo JLG4 15.105
- 9:06 pm London GSC 9.58
- 9:15 pm Komsomolsk — 15.11, 15.23
- 9:30 pm Berne HER4 9.54
- 9:45 pm Vichy — 9.62
- 10:00 pm Riode Janeiro PRL8 11.72
- 10:30 pm Rome 2RO3 9.63
- 10:45 pm London GSC 9.58
- 11:00 pm Berlin DXJ 7.24
- 11:30 pm Rome 2RO3 9.63
- 12 midnight Berlin DXJ 7.24
- 12:30 am London GSC 9.58  
GRX 9.69  
GSL 6.11
- 1:00 am Batavia — 18.135
- 1:00 am Berlin DXJ 7.24
- 1:10 am Melbourne VLG6 15.23

Reports for the past month were received from Gilbert L. Harris, of Massachusetts; Bob Hoiermann of Ohio; Winslow Williams of New York; Nick Vangellow of New York; L. R. Brown of Pennsylvania; Bill Buehrle, Jr., of Missouri; Thomas W. Purdy of Toronto, Canada; and Frank Heiss of Rhode Island. Through the co-operation of the following, we have been able to revise our lists of stations, and make many corrections in our schedules:— The British Broadcasting Corporation, General Electric Company, National Broadcasting Company, Columbia Broadcasting Corporation, United Network, New York State Chamber of Commerce, Co-ordinator of Inter-American Affairs, National Association of Broadcasters, Station WCAU, and the San Francisco Chamber of Commerce.

Mc.	Call	Location and Schedule	Mc.	Call	Location and Schedule	Mc.	Call	Location and Schedule
4.70	ZQI	KINGSTON, JAMAICA. Sundays, 6:15 to 6:55 pm; daily 6:15 to 7:15 pm.	6.007	ZRH	JOHANNESBURG, SOUTH AFRICA. Evening transmissions.	6.080	WLWO	CINCINNATI, OHIO. 12:45 to 1 am.
4.785	HJAB	BARRANQUILLA, COLOMBIA.	6.010	CJCX	SYDNEY, NOVA SCOTIA. Monday to Friday, 7 am to 11 am; Saturday, 6:45 am to 11 am; Sundays, 8 am to 11 am.	6.082	OAX4Z	LIMA, PERU. "Radio Nacional."
4.835	HJAD	CARTAGENA, COLOMBIA.	6.020	—	GEORGETOWN, BRITISH GUIANA. 7 am to ?	6.090	CBFW	VERCHERES, CANADA. Daily, 7:30 am to 11:30 pm in French.
4.865	HJFK	PEREIRA, COLOMBIA.	6.02	—	"GUSTAV SIEGFRIED EINS." Variable times of evening.	6.09	ZNS2	NASSAU, BAHAMAS. Evening transmissions.
4.885	HJDP	MEDELLIN, COLOMBIA.	6.030	HP5F	COLON, PANAMA. 11 pm to ?	6.095	OAX4H	LIMA, PERU. "Radio Mundial."
4.905	HJAG	BARRANQUILLA, COLOMBIA.	6.03	DXP	BERLIN, GERMANY.	6.098	ZRK	CAPTOWN, SOUTH AFRICA. Day and night transmissions.
4.92	YV5RN	CARACAS, VENEZUELA. Evening transmissions.	6.030	CFVP	CALGARY, CANADA. Sunday, 10 am to 1:30 am; Monday to Saturday, 8:30 am to 2 am.	6.11	GSL	LONDON, ENGLAND. American beam, 7 pm to 12:45 am.
4.925	HJAP	CARTAGENA, COLOMBIA.	6.04	COBF	HAVANA, CUBA. Relays CMBF.	6.120	—	BERLIN, GERMANY. North American beam, variable times.
5.85	—	SANTIAGO, CHILE; 7:40 pm to midnight.	6.070	CFRX	TORONTO, CANADA. Sundays, 9 am to 12 midnight; Monday to Friday, 7:30 am to 12:05 am; Saturday, 7:30 am to 12:45 am.	6.120	WKTS	12:45 to 1 am.
5.980	VONH-VONG	ST. JOHNS, NEWFOUNDLAND; 7:30 to 8:15 pm.				6.12	—	"GUSTAV SIEGFRIED EINS". Variable times of evening.
5.44	—	MOSCOW, USSR. 6:48 to 7:25 pm.						
5.875	TIGPH	SAN JOSE, COSTA RICA						
6.005	CFCX	MONTREAL, CANADA. Sunday, 7:30 am to 12 midnight; Monday to Saturday, 6:45 am to 12 midnight.						

(Continued on following page)

# • LISTENING POST •

Mc.	Call	Location and Schedule	Mc.	Call	Location and Schedule	Mc.	Call	Location and Schedule
6.122	ZFA2	HAMILTON BERMUDA. Mondays, 7 to 7:45 pm.	7.565	WKLJ	NEW YORK CITY; 12:45 to 1 am.	9.59	—	"VOICE OF FREE INDIA." 9 to 11 pm.
6.130	COCD	HAVANA, CUBA; 7 pm to midnight.	7.660	YNDG	LEON, NICARAGUA. 7:30 pm to ?	9.59	—	"NATIONAL CONGRESS RADIO". 11:15 to 11:55 pm.
6.130	CHNX	HALIFAX, NOVA SCOTIA. Sundays, 8 am to 6:55 pm; Monday to Thursday, 6:45 am to 10:15 pm; Friday, 6:45 am to 11 am; Saturday, 6:45 am to 11 am.	7.820	WKRD	12:45 to 1 am.	9.595	—	ATHLONE, IRELAND. "Radio Eireann," 7:10 to 8 pm.
6.145	HJDE	MEDELLIN, COLOMBIA. Evening transmissions.	8.030	FXE	BEIRUT-LEBANON. 6:30 to 6:45 pm; irregular.	9.615	TIPG	SAN JOSE, COSTA RICA; "La Voz de la Victor"
6.148	ZRD	DURBAN, SOUTH AFRICA. Day and night transmissions.	8.035	CNR	RABAT, MOROCCO.	9.620	—	VOICE OF FREE FRANCE. 4 to 5 pm; 9:45 to 10:15 pm.
6.150	CJRO	WINNIPEG, Canada. 6 to 11 pm.	8.484	XPSA	KWEIYANG, CHINA. 7:30 am to 12 noon.	9.62	—	VICHY, FRANCE. North American beam, 9:45 pm.
6.160	CBRX	VANCOUVER, CANADA. 10:30 am to 2:30 am.	8.930	KES2	PACIFIC COAST; 6:15 am to 1 pm.	9.626	ZRL	CAPE TOWN, SOUTH AFRICA. Daylight transmissions.
6.165	TILS	SAN PEDRO, COSTA RICA.	8.955	COKG	SANTIAGO, CHILE. Evening transmissions.	9.630	2RO3	ROME, ITALY; 6:30 pm to midnight.
6.165	—	BERNE, SWITZERLAND; Canadian beam, 9 to 11 pm, except Saturday.	8.96	AFHQ	ALGIERS. 6:30 to 7:45 pm; irregular.	9.635	XGOY	CHUNGKING, CHINA. East Asia beam, 7:35 to 9:55 am; 2:30 to 4 pm; European beam, 11:35 am to 12:30 pm; 4 to 5 pm; North American beam, 10 to 11:30 am.
6.170	WCBX	NEW YORK CITY; 11:45 pm to 3 am.	9.04	—	FRENCH EQUATORIAL AFRICA. "Radio Club"; 9 to 10:20 am; 2 to 3:20 pm; 5 to 5:30 pm.	9.637	—	"GUSTAV SIEGFRIED EINS". Variable times of evening.
6.190	WGEO	SCHENECTADY, NEW YORK; 12:15 to 2:10 am.	9.125	HAT4	BUDAPEST, HUNGARY. 9:15 to 9:30 pm; 10:15 to 10:30 pm.	9.64	COX	HAVANA, CUBA. 1 to 11:15 pm.
6.19	—	"GUSTAV SIEGFRIED EINS". Variable times of evening.	9.437	COCH	HAVANA, CUBA. Evenings.	9.64	KZRH	MANILA, PHILIPPINES.
6.210	—	"DEUTSCHER KURZWELLEN SENDER ATLANTIC". Evenings, variable times; thought to be anti-nazi station.	9.465	TAP	ANKARA, TURKEY.	9.645	LLH	OSLO, NORWAY.
6.235	—	"GUSTAV SIEGFRIED EINS". Variable times of evening.	9.47	JZHA	HONG KONG	9.645	—	"GUSTAV SIEGFRIED EINS". Variable times of evening.
6.480	TGWB	GUATEMALA CITY, GUATEMALA. 7 am to 8:10 pm daily, except Sunday.	9.48	—	MOSCOW, USSR. 6:48 to 11 pm.	9.650	WCRC	NEW YORK CITY; 12:15 to 2 am.
6.485	HI2T	SAN FRANCISCO DE MACORIS, DOMINICAN REPUBLIC.	9.490	WCBX	NEW YORK CITY; 7:55 to 11:30 pm.	9.670	WNBI	NEW YORK CITY; 12:15 to 2 am; 4:30 to 6 pm.
6.700	TIEP	SAN JOSE, COSTA RICA; "La Voz del Tropic"	9.490	KRCA	PACIFIC COAST; 1 am to 1 pm.	9.67	COCQ	HAVANA, CUBA. Evening transmissions.
7.037	EAJ3	VALENCIA, SPAIN; 4 to 6 pm.	9.50	XEWW	MEXICO CITY, MEXICO. Evening transmissions.	9.685	TGWA	GUATEMALA CITY, GUATEMALA. Night transmissions.
7.15	GRT	LONDON, ENGLAND. 10:45 pm to 12 midnight.	9.505	JLG2	TOKYO, JAPAN. 7:30 to 7:45 am; 8 to 8:45 am.	9.69	LRAI	BUENOS AIRES, ARGENTINA; off at present time.
7.171	XGOY	CHUNGKING, CHINA. East Asia beam, 7:35 to 9:55 am; 2:30-4 pm; European beam, 11:35 am to 12:30 pm; 4 to 5 pm; Asia-Australia-New Zealand beam, 6 to 6:30 am; East Russia beam, 6:30 to 7 am; Japan beam, 7 to 7:30 am; North American beam, 10 to 11:30 am.	9.520	—	GENEVA, SWITZERLAND. 9 to 10:45 pm.	9.690	GRX	LONDON, ENGLAND. 10:45 pm to 12:45 am.
7.230	KWID	SAN FRANCISCO, CALIFORNIA; 6:30 am to 1:05 pm.	9.52	DZD	BERLIN, GERMANY. North American beam; evenings.	9.700	WRUW	BOSTON, MASSACHUSETTS; 11 pm to 2 am.
7.230	—	ROME, ITALY. Day and night transmissions; news in English every hour.	9.523	ZRH	JOHANNESBURG, SOUTH AFRICA. Daylight transmissions.	9.7	—	FORT DE FRANCE, MARTINIQUE
7.250	KGEI	SAN FRANCISCO, CALIFORNIA, 1 am to 1 pm.	9.530	—	BERNE, SWITZERLAND; U.S.A. beam, 9 to 11 pm except Saturday.	9.720	PRL7	RIO DE JANEIRO, BRAZIL; "Radio Nacional"; 6 to 9:55 pm.
7.28	VLI9	SYDNEY, AUSTRALIA; Eastern North American beam, [English] 8 am.	9.530	WGEO	SCHENECTADY, NEW YORK; 5:30 pm to midnight.	9.720	XGOA	CHUNGKING, CHINA. 7 am to 1 pm.
7.290	DJX	BERLIN. Variable times, North American beam; news in English at 7 pm and other times.	9.530	WGEA	SCHENECTADY, NEW YORK; 3:30 to 6 am.	9.735	CSW7	LISBON, PORTUGAL.
7.31	2RO19	ROME, ITALY. Day and night transmissions; news in English every hour.	9.535	HER4	GENEVA, SWITZERLAND. North American beam, 9:30 to ? pm, except Saturdays.	9.750	WCDA	NEW YORK CITY; midnight to 2 am.
7.345	—	GUAYAQUIL, ECUADOR. 9 to 11 pm.	9.535	JZI	TOKYO, JAPAN. 2:15 pm; 7 to 9:30 pm; 7:30 to 7:45 am; 8 to 8:45 am.	9.750	—	ROME, ITALY. Day and night transmissions.
7.495	—	CAIRO, EGYPT. 3:15 to 6 pm.	9.535	SBU	MOTALA, SWEDEN. 12 to 2:15 pm.	9.755	—	DURBAN, SOUTH AFRICA. Day and night transmissions.
7.565	KWY	PACIFIC COAST; 4:45 to 7:05 am; 8 to 10:30 am	9.540	VLG2	MELBOURNE, AUSTRALIA. 8 to 8:45 am.	9.760	WKLJ	NEW YORK CITY
			9.54	HER4	GENEVA, SWITZERLAND.	9.780	—	ITALIAN UNDERCOVER STATION; variable times of evenings; sometimes afternoons.
			9.543	XEFT	MEXICO CITY, MEXICO. Evenings.	9.835	—	"FREEDOM STATION." 2:15 to 2:27 pm, 7:15 to 7:27 pm; speaks German.
			9.545	—	"GUSTAV SIEGFRIED EINS." Variable times of evening.	9.84	CR7BE	MOZAMBIQUE; News in English, 4:50 pm daily.
			9.545	—	KOMSOMOLSK, SIBERIA, USSR. 7:40 to 8:20 am; 10:15 to 10:30 am.	9.86	EAQ	MADRID, SPAIN.
			9.562	OAX4T	LIMA, PERU. "Radio Nacional" 2 to 8 pm, daily.	9.897	KROJ	LOS ANGELES, CALIFORNIA; 11 pm to 1:45 pm.
			9.565	JRAK	TOKYO, JAPAN. 7 to 9:30 pm.	9.905	WKRX	NEW YORK CITY
			9.570	KWID	SAN FRANCISCO, CALIFORNIA; 3 to 6:15 am.	9.935	SVM	ATHENS, GREECE
			9.58	VLG	MELBOURNE, AUSTRALIA; Western North American beam, in English, 11 am.	9.98	—	FRENCH EQUATORIAL AFRICA. "Radio Club"; 9 to 10:20 am; 2 to 3:20 pm; 5 to 5:30 pm.
			9.580	GSC	LONDON. North American beam, 5:15 pm to 12:45 am.	10.005	—	"VOICE OF FREE ARABS". Sundays, 3:15 to 3:30 pm, irregular.
			9.590	WLWK	CINCINNATI, OHIO; midnight to 9 am.	10.055	SUV	CAIRO, EGYPT. Afternoons; irregular.
			9.59	WLWO	CINCINNATI, OHIO; 8:30 pm to midnight.			

(Continued on page 760)

# SPRAGUE TRADING POST

## Your Own Ad Run FREE

The "Trading Post" is Sprague's way of helping radio servicemen obtain the parts and equipment they need, or dispose of the things they do not need during this period of wartime shortages. Send in your own ad today—to appear free of charge in this or one of several other leading radio magazines on our list. Keep it short—WRITE CLEARLY—and confine it to radio items. "Emergency" ads will receive first attention. Address it to:

SPRAGUE PRODUCTS CO., Dept. RC 39  
North Adams, Mass.

**TUBES WANTED**—Will swap for or buy all popular tube types. Have all types of condensers, transformers, also condenser tester and 4 1/2 amp. rotary converter A.C. to D.C. Berkley's, 112-43 Queens Blvd., Forest Hills, L. I., N. Y.

**RECEIVERS WANTED**—Want inexpensive commercial receivers in working condition. Write giving full details. Intimate Bookshop, Chapel Hill, N. C.

**URGENTLY NEEDED**—Model #834 Precision V.O.M.; Condenser Analyzer; tube tester; portable signal generator. Need for repair of morale sets at army post. Must be priced reasonable. Send full details. T5th Geo. Yarbrough, Btry. C, 1st C.A., A.P.O. 836, c/o P. M., New Orleans, La.

**TUBE CHECKER WANTED**—To handle all tube types. Also want signal tracer and other service instruments for cash. Hank's Radio Service, Box 13, Easton, Minn.

**AMPLIFIER & DRAFTING EQUIPMENT FOR SALE OR EXCHANGE**—One 12-watt amplifier, 2A3 push-pull output. Present tube complement used less than 14 hrs. \$21.50. Also have set of drafting eqpt. used once. Includes two pens, three bow compasses, 2 dividers, 2 pencils, squares, triangles, etc. \$23.50. I want radio testing eqpt., especially a set tester and an ohmmeter. Edmund H. Dean, Falls Village, Conn.

**COMMUNICATION RECEIVER WANTED**—Short wave model. State price and condition. Paul R. Schramm, 2765 W. Carmen Ave., Chicago 25, Illinois.

**WANTED**—RCP #802-803 comb. tube and set tester, any condition, providing meter is good. Also want battery-operated Signal generator. State cash price in 1st letter. Nathaniel Bell, 415 N. Parramore St., Orlando, Fla.

**COMMUNICATIONS RECEIVER WANTED**—In good condition. Give full details and name price. Walter J. Hotaling, R.D. #1, Unadilla, N. Y.

**TUBE TESTER FOR SALE**—Daco counter model. Write for details. A. L. Heintz, Minster, Ohio.

**WANTED**—One Triplett 666 Universal volt-ohm-milliammeter, or a tester with similar readings. Must

be in A-1 condition. State price. Durand Sales Co., 315 Dousman, Green Bay, Wis.

**WANTED**—Tube tester, Philco model 050, or Readrite Ranger 432A, or any well-known make. National Radio Service, 506 Warburton Ave., Yonkers, N. Y.

**WILL EXCHANGE**—One complete "Popular Educator" Course (new) value \$14; one 1931 Gernsback official radio service manual; one \$35 Unekin complete with bow, 100 songs, etc.; one six volt mantel model 5-tube radio. Will swap all or parts for radio parts, magazines, books, etc. of equal value. Clyde R. Wood, P. O. Box 296, Yellow Jacket, Colo.

**FOR SALE OR TRADE**—Remington adding machine, like new, adds to 9 million, subtracts, multiplies, figures fractions. Will trade for Supreme 585 Radio tube and set tester, or later model with oscillator and cathode ray oscilloscope. C. M. Rebelein, Kiester, Minn.

**WANTED**—V.O.M. meter, combination tube and set tester output meter, and capacitor analyzer. E. L. Johnston, 172 W. North Street, Akron, Ohio.

**WANTED FOR CASH**—30 feet of single conductor microphone cable, new or used, in two pieces, if necessary. Clement Blair, Box 86, Gap, Pa.

**'SCOPE FOR SALE**—One 2" Triplett scope; also one frequency modulated signal generator, making a matched set; will sell the pair for \$70, F.O.B. Also 2 metal locators or radio treasure finders complete. Kenneth E. Mayhall, Belmont, Miss.

**URGENTLY NEEDED**—Signal generator, of the modulated type, with a range of 100 K.C. to 100 M.C., for F.M. and A.M. receivers; also multimeter to cover from 0 to 2 meg. resistance, 0 to 5000 D.C., and 0 to 5000 A.C. volts at 1000 ohms per volt. Cash for either or both. R. Hockey Radio Shop, 3902 Tyler, Berkley, Mich.

**FOR TRADE**—Hallcrafters S 20 R, original condition, for one of the following electronic multimeters: Weston 669, Supreme 549, R.C.P. 662. Must be in good condition. Give details and price. Carol Radio, 115 Withhoff St., Queens Village, L. I.

**WANTED**—Hallcrafters SX28 or SX32 and 2 1/2 meter equipment. Will pay highest cash prices or swap Zenith portable and Hallcrafters HT4. Paul K. Heim, Seminary Campus, Gettysburg, Pa., c/o Radio Dept.

**WANTED**—A.C.-D.C. multimeter and signal generator, new or in good condition. Will pay cash. F. Stuart Godfrey, 602 E. State St., Saint Johns, Michigan.

**EQUIPMENT FOR SALE**—Hickok #18 signal generator; Supreme 3" scope; RCA Model 156 Tube Tester (factory revised); Superior X-Rayometer, v.o.m. up to 30 meg.; Simpson Model 325 (9" meter) counter tube tester; Triplett #1200A twin meter, 2000 ohms per volt analyzer; Stancor super pack 115 V. A.C. to 6 V. at 12.5 amps.; two G-E handy phone intercommunications, receivers model EM-43C. What am I offered? Harry Sklar, 146 Myrtle Ave., Jersey City (5), N. J.

**WANTED**—Volt ohmmeter A.C.-D.C. volts, 1000 ohms resistance per volt. Urgently needed. Eldred Sherrill, Lapulpa, Okla. (General Delivery.)

**TEST EQUIPMENT WANTED**—Tube tester, pocket size tester, bench tester, etc. Write giving price and details. Victor D. Letourneau, Jr., 179 Main St., Holyoke, Mass.

**CONVERTER WANTED**—32 to 110 volt, 300 to 500 watts. Give price and details. Milo W. C. Wilson, Bellefonte, Route 2, Pa.

**WANTED FOR CASH**—CB1-60 Solar condenser and capacity analyzer; 5 volt A.C. meter (Western or Triplett); 5 amp. A.C. meter. Must be in A-1 condition. All replies answered. Wm. H. Zink, 618 N. Chester St., Baltimore 5, Md.

**WANTED AT ONCE**—Montgomery Ward portable phonograph with spring drive. Ray Hauser, P. O. Box 55, Litchfield, Ill.

**TUBE TESTER WANTED**—Will pay cash for Radio City 312-C tube tester, or Triplett model 1612 in good condition. J. B. Patrizi, 115 W. Sherman Ave., Newark, N. J.

**C-R TUBE WANTED**—Want cathode ray tube for Philco 022 'scope. #2152. Will pay cash. J. R. Jones Radio Service, Hamden, Ohio.

**FOR SALE**—4 ICA and 4 Bruno s-w coils; 140 mmfd. condensers; 300 tubes in sealed cartons (some open, but not used)—guaranteed test; power packs, 180 volts to 400 v. D. C. Priced low. Enclose stamp for detailed reply. W. F. Ouder, Rt. 1, Box 389, Kimmswick, Mo.

## FREE SERVICE DATA: Making 18 "Victory Line" Capacitors do the Work of 473!

Vital materials MUST be conserved for war uses—and this means that servicemen are now faced with the problem of making a "Victory Line" assortment of 18 Capacitors do the work of the approximately 473 replacement types and sizes previously supplied for this work.

But servicemen will cooperate accordingly! They'll use 'em—and they'll make these 18 types fill the bill! What's more, they'll get all the help Sprague can give them in solving the headaches that are bound to arise.

WRITE TODAY for your free

copy of the Sprague "VICTORY LINE" Folder. In addition to listing the 9 Atom Electrolytics and the 9 TC Tubulars now available under wartime restrictions, this contains helpful data for those applications where some real "juggling" must be involved. It tells you, for instance, how to replace 600 volt Capacitors with available 450 volt types; how to use dries on wet electrolytic jobs, and much more.

It's a folder that will prove invaluable in your daily work.

DON'T MISS IT!



SPRAGUE PRODUCTS CO.

North Adams, Mass.

# SPRAGUE CONDENSERS AND KOOLOHM RESISTORS

Obviously, Sprague cannot assume any responsibility for, or guarantee goods, etc., which might be sold or exchanged through above classified advertisements.

# • LATEST RADIO APPARATUS •

## NEW TALK-A-PHONE

Talk-A-Phone Mfg. Co.,  
Chicago, Illinois

THIS system, known as Model LP-77, utilizes in any combination up to ten, both Master Stations and a new "Selector Type" Sub-station. Now, in one system, Master Stations may carry on a completely private conversation between each other without interruption or eavesdropping by the remote stations, and, in addition, may communicate with the different Sub-stations at will. Any Master Station may also have a private Sub-station with which no other Master can communicate or listen in on.

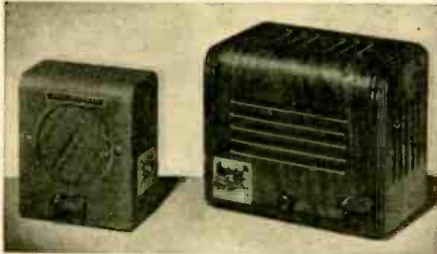

With the new innovation of "Selector Type" Sub-stations, these outlying stations can now select the Master to which they wish to speak and originate the call. Thus a completely flexible inter-office communication system may be had with instant contact to all vital points without the use of a central switchboard operator.

Master Stations can call one another regardless of whether the station being called has power on or not. Systems may be built up progressively beginning with two units to any amount of stations desired. Variable volume control is adjusted at each Master unit from a whisper to full room volume. Stations can be placed at any distance up to 2000 ft. from each other. The system also uses the exclusive time-tested Talk-A-Phone "Silent Feature."

Operation on the system is 110 volts, AC-DC. Master Stations are housed in sturdy walnut cabinets, and Sub-stations are completely enclosed in durable metal cases. These systems are available in 10, 20, 30, 40, 50, etc., stations.—Radio-Craft

## SPACE-SAVING CAPACITOR

Aerovox Corporation  
New Bedford, Mass.

A POPULAR type of oil capacitor because of its handy inverted screw mounting and compact dimensions, the Aerovox Type 10 is now further improved by the new double-terminal feature. Heretofore this capacitor has had a single insulated terminal and grounded can, although when screw-mounted on a metal chassis it could be fully insulated by an insulating washer.

The new double-terminal feature means that both terminal lugs are insulated from

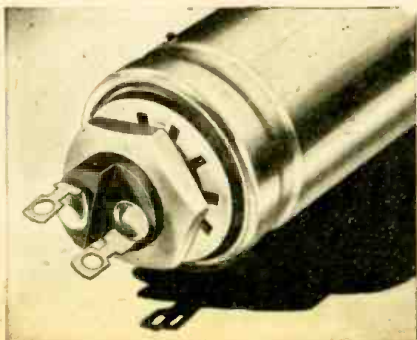

the "floating" can and no insulating washer is required. These capacitors, made by Aerovox Corporation of New Bedford, Mass., are hermetically sealed and will pass all immersion tests required by Governmental agencies. This is accomplished by the use of the new one-piece molded bakelite terminal assembly which prevents penetration of moisture and leakage of oil. These capacitors, available on high priorities only, are filled with either Hyvol vegetable oil or mineral oil, rated up to 4.0 mfd. at 600 v. D.C. and to .5 mfd. at 1500 v. D.C. The can, similar in design and dimensions to the usual inverted-screw-mounting metal-can electrolytics, is of aluminum or an approved substitute.

—Radio-Craft

## CONNECTOR FOR RACK USE

Cannon Electric Development Co.  
Los Angeles, Calif.

THE newest member of the Cannon DP line of electrical connectors is the DP-B10C2. This is classed as a rack type connector and is adapted by its design to radio rack assemblies, transmitters and any general applications where both plug and receptacle must be fixed permanently in their respective units of equipment.

Differing radically from the standard round or oval faced connectors, the DP-B is rectangular and is so designed to fit rack equipment. The shell is tapered to effect a close fit when engaged and the two units of the complete connector are self aligning but are dependent upon the accuracy of the equipment it connects.

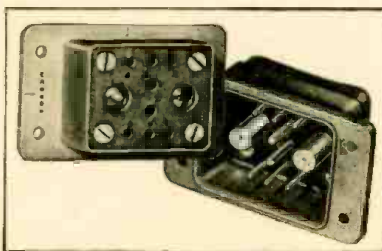

The insert insulation is made of molded phenolic, having 8 standard contacts of brass, silver-plated, and 2 coaxial contacts of the same material and finish, with insulating insulators. Two contacts are 30 Amp. and 6 are 15 Amp. Shell is die-cast aluminum alloy, with sand blast and clear lacquer finish. Four mounting holes have diameter of .144 countersunk for No. 8 flat head machine screws. Weight of Receptacle .276 (lbs.) and plug .266 (lbs.)

—Radio-Craft

## SUPER-SMALL RELAYS

Automatic Electric Co.  
Chicago, Illinois.

A NEW line of relays, these are very small in size but provide large contact capacity and a wide range of operate and release speeds. Typical assemblies having a maximum of six contact springs are only  $\frac{3}{4}$ " x  $1\frac{1}{2}$ " x  $1\frac{3}{8}$ " in size, and weigh  $1\frac{1}{4}$  oz. Assemblies with a maximum capacity of 12 springs are slightly larger, and weigh about 2 oz. Relays can be supplied with any number of springs up to the maximum, and with any combination of "make", "break" and "break-make" contact arrangements. Standard contacts will make or break 1 amp. non-inductive or  $\frac{1}{2}$ -amp. inductive load, and will carry 2 amps.

These relays, which are known as Class "S" relays, have contact springs of unique shape, with independent twin contacts de-

signed to assure one contact "making" even if the other contact is held open by dust or grit. Operate speeds range from 4 to 25 milliseconds; release speeds from 2 to 10 milliseconds (or up to 70 milliseconds, through the use of special coils). Coils from 150 to 3500 ohms can be supplied, for operation at up to 115 volts; larger coils, up to 10,000 ohms, permit operation at up to 175 volts, or with release delay of up to 80 milliseconds at 115 volts. Insulation of coils and springs is tested at 500 volts, A.C.

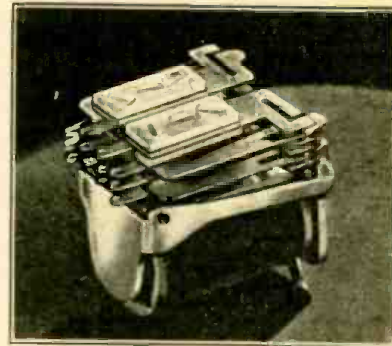

Vibration resistance, provided by torsion instead of power-wasting friction, insures against false operation or release of contacts at up to 10.5 G, as determined by a cathode-ray oscillograph and stroboscopic examination. Other features of importance in aircraft and other services include extreme resistance to humidity, and to temperatures from -40 degrees F. to +130 degrees F.—Radio-Craft

## SOLDERLESS TERMINAL

Aircraft-Marine Products, Inc.  
Elizabeth, New Jersey

THESE new solderless flag type terminals meet the need for stacking a series of parallel terminal connections on a single stud block without loss of space or electrical conductivity. This is made possible by a unique design plus a sufficiently flexible tongue to permit multiple stacking after wiring. They may be used for either right or left hand application—since the terminal barrel is symmetrically located with respect to the plane of the tongue. This eliminates the necessity of distinguishing between and stacking two different terminals, thereby simplifying installation and speeding production.

For wire sizes 22 to 10, the terminals are pure copper of maximum conductivity, hot electro-tinned for maximum corrosion resistance.

No solder is necessary—the terminals are crimped on wire with hand, foot, or power tools, and are speedily installed. Special designs for particular applications are available.—Radio-Craft

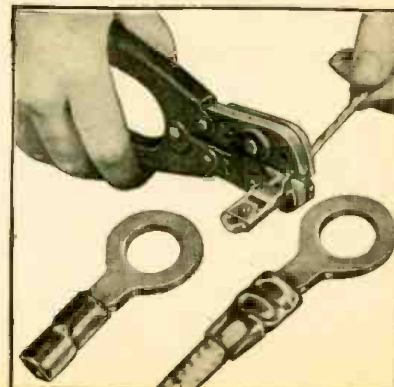

**-THAT'S HOGARTH,  
HE'S DIGGING A FOX-HOLE ANNEX  
FOR HIS ECHOPHONE EC-1!**



**Echophone Model EC-1**

(Illustrated) a compact communications receiver with every necessary feature for good reception. Covers from 550 kc. to 30 mc. on three bands. Electrical bandspread on all bands. Six tubes. Self-contained speaker. Operates on 115-125 volts AC or DC.



**ECHOPHONE RADIO CO., 201 EAST 26th ST., CHICAGO, ILLINOIS**

# THE QUESTION BOX

## QUERIES

All queries should be accompanied by a fee of 25c to cover research involved. If a schematic or diagram is wanted please send 50c, to cover circuits up to 5 tubes; for 5 to 8 tube circuits, 75c; over 8 tubes, \$1.00.  
 Be sure to send the fullest possible details when asking questions. Give names and MODEL NUMBERS when referring to receivers. Include schematics of your apparatus whenever you have such. Serial numbers of radios are useless as a means of identification.  
 All letters must be signed and carry FULL ADDRESS. Queries will be answered by mail, and those of general interest reprinted here. Do not use postcards—postmarks often make them illegible.  
 No picture diagrams can be supplied.  
 Back issues 1942, 25c each; 1941, 30c each; 1940, 35c each.  
 Any issue, prior to 1940, if in stock, 50c per copy.

### BATTERY SET WITH NEW-TYPE TUBES

? Please send me a diagram for a receiver using a 1LC6, 1LC5, 1LD5 and 1LB4.  
 —R.A.L., Modesto, Calif.

A. The diagram is printed here. All

values are in ohms or microfarads, except where otherwise stated. A standard .00365-mfd. 2-gang condenser is used with a regular set of broadcast and oscillator coils.

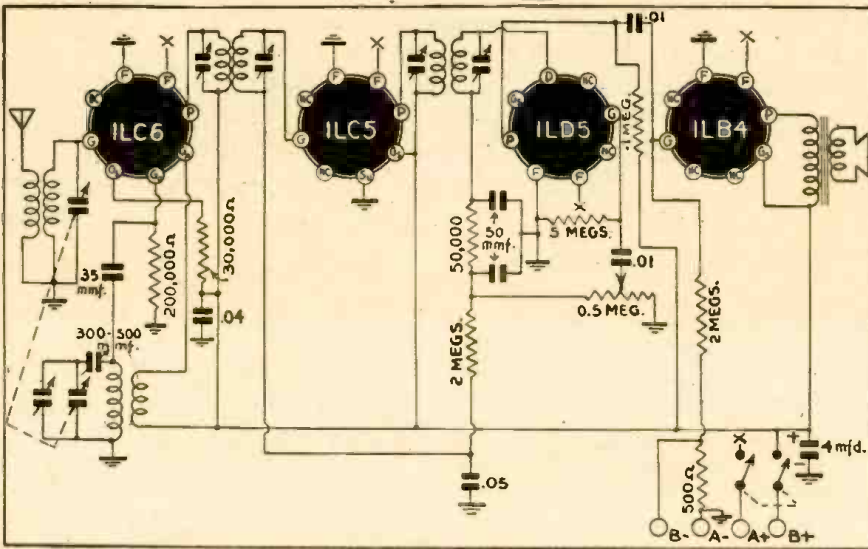

### THE AUSTRALIAN "KANGAROO" INVERTER

? I wish if it is possible to obtain a diagram for resistance coupling a single 56, 76 or 6C5 to push-pull 56's, 76's or 6C5's. I would appreciate any information on this that is possible to obtain.—H.S.B.B., Negritos, Peru.

A. Since you did not state what you intend to use this circuit for, I can only suggest the output.

The unit itself will have little gain. This is because the inverter tube adds practically nothing to the signal, merely splitting it so that the two grids of the next stage will receive equal impulses. You may get more gain by adding another tube ahead of your phase inverter.

This circuit came originally from Australia, and is known as the "Kangaroo."

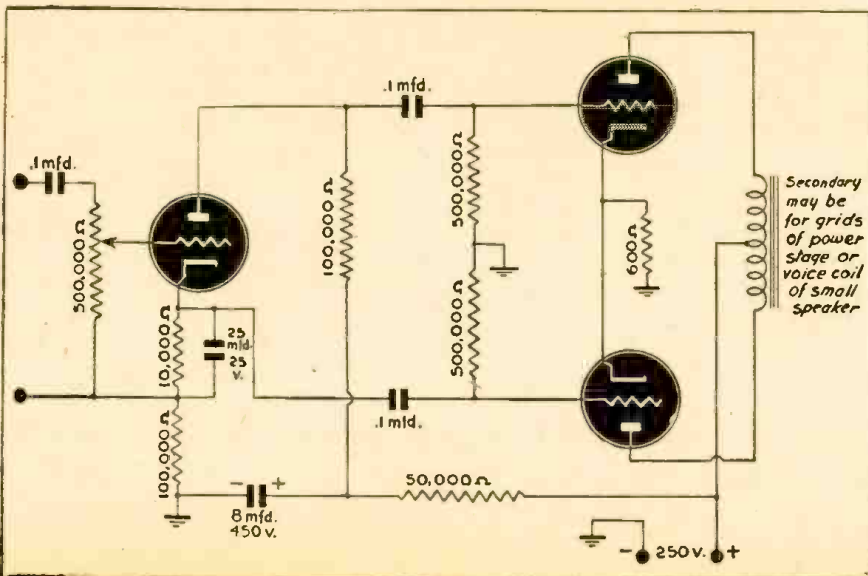

### A COLLECTION OF QUESTIONS

? Can you please supply the answers to my private collection of radio questions? They are as follows:

Does inverse feedback affect the maximum power output of an amplifier? Would a pentode or beam tube acquire the desirable characteristics of a triode (low distortion) and also retain its relatively high power efficiency if excessive I.F.B. and an additional voltage pre-amplifier be used?  
 —V.J.F., Milwaukee, Wis.

A. Feedback-type amplifiers are rated for the same power output as those using the same tubes without inverse feedback. As you suggest, additional input voltage is required. As for the second part of the question, "excessive" inverse feedback is by very definition enough feedback to produce undesirable effects. If you simply mean "large but not excessive" amounts of feedback, the answer is yes. Pentodes and other tubes of high output impedance acquire some of the desirable characteristics of triodes under those conditions. It is possible that I do not entirely understand the question.

? What is the unit of electrical energy and how is it related to Ohm's Law?

A. The unit of electrical energy is the joule—it is defined as the amount of energy required to drive one coulomb through an opposing potential of one volt. It may be related to Ohm's Law through the watt, as a joule is a watt-second.

? Does electromotive force affect the speed of electrons? According to Hoyle, (can he mean Morecroft?—Editor) the speed of electricity is a constant (namely, 186,270 miles per second), but some textbooks use voltage and velocity interchangeably when referring to both electric and electronic actions.

A. The maximum speed of electricity is in the order of 186,000 miles per second. The electrons you have been reading about have to start from scratch—that is, a standing position in the cathode of a tube—and naturally do not start out at full speed, any more than would a locomotive. They speed up according to the voltage which attracts them, so you may read a term as "... accelerated through x volts."

? Are space-charge amplifiers practical? If so, are they capable of higher gain than the normal pentode circuit for direct voltage amplification?

A. Space-charge amplifiers have not been widely used, which might indicate that they are not practical. If by space-charge circuit, you refer to a two-grid tube with the inner grid kept at a constant voltage higher than that of the cathode, and the outer grid used for control, the gain must necessarily be lower than with a normal pentode circuit.



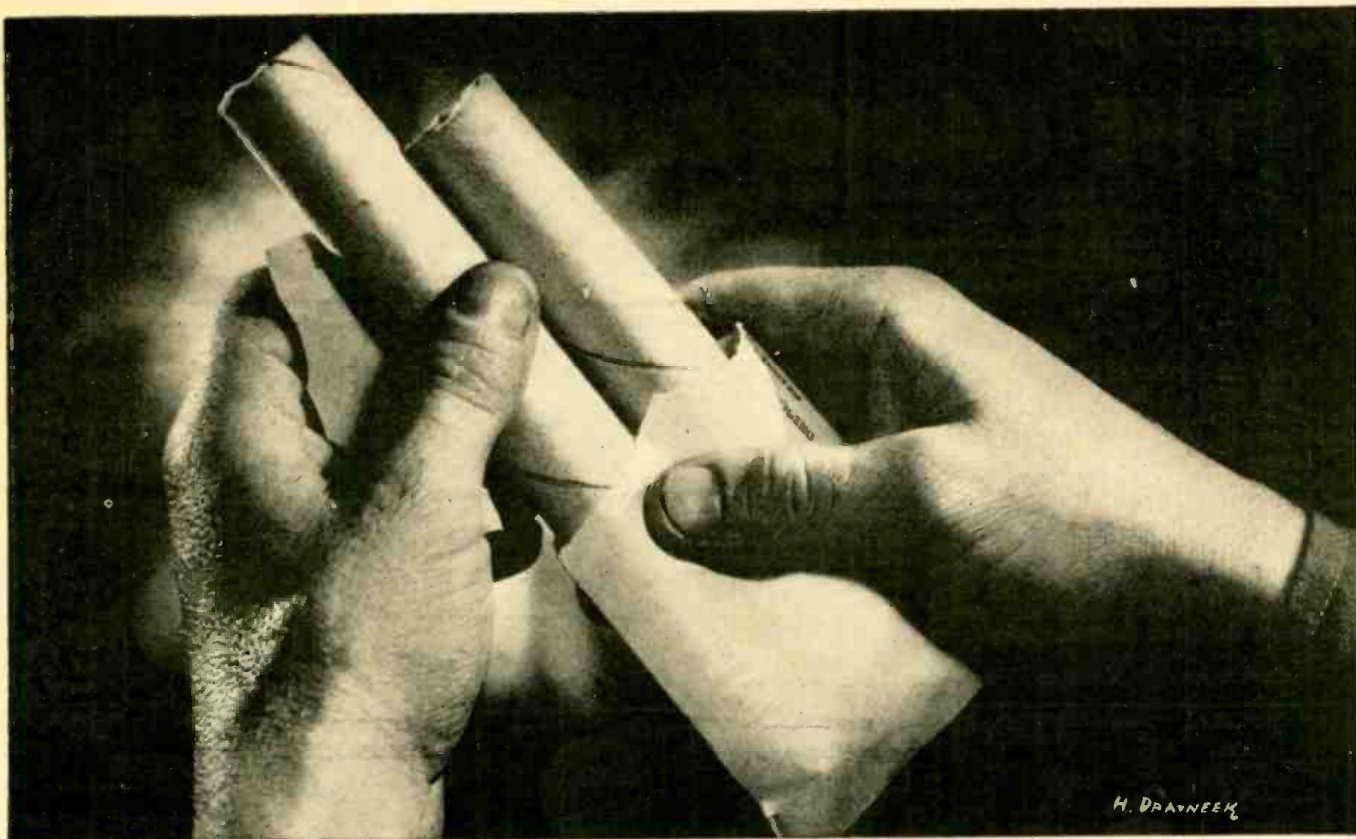

## Mister—you're getting paid in DYNAMITE!

**L**ET'S NOT KID OURSELVES about this. Our pay envelope today is dynamite.

If we handle it *wrong*, it can blow up in our face . . . lengthen the war . . . and maybe wreck our chances of having happiness and security *after* the war.

**The wrong way to handle it...and why**

The wrong way is for us to be good-time Charlies. To wink at prices that look too steep . . . telling ourselves we can afford to splurge.

We *can't* afford to—whether we're business men, farmers, or workers. And here's why:

Splurging will boost prices. First on one thing, then all along the line.

Then, wages will have to go up to meet higher prices. And higher wages will push prices up some more . . . faster and faster, like a runaway snowball.

The reason this can happen is that there is more money in pay envelopes today than there are things to buy with it. This year, we Americans will have *45 billion* dollars more income than there are goods and services to buy at present prices. *45 billion dollars extra money!*

That's the dynamite!

**The right way to handle it...and why**  
Our Government is doing a lot of things to

keep the cost of living from snow-balling.

Rationing helps. Price ceilings help. Wage-and-rent stabilization helps. Higher taxes help. They're *controls* on those dangerous excess dollars.

*But the real control is in our hands. Yours. Mine.*

It won't be fun. It will mean sacrifice and penny-pinching. But it's the only way we can win this war . . . pay for it . . . and keep America a going nation afterwards.

And, after all, the sacrifice of tightening our belts and doing without is a small sacrifice compared with giving your life or your blood in battle!

**Here's what You must do**

**Buy only what you absolutely need.** And this means absolutely. If you're tempted, think what a front-line soldier finds he can get along without.

**Don't ask higher prices**—for your own labor, your own services, or goods you sell.

Resist pressure to force YOUR prices up.

**Buy rationed goods only by exchanging stamps.** Shun the Black Market as you would the plague.

**Don't pay a cent above ceiling prices.**

**Take a grin-and-bear-it attitude on taxes.** They must get heavier. But remember, these taxes help pay for Victory.

**Pay off your debts. Don't make new ones.** Getting yourself in the clear helps keep your Country in the clear.

**Start a savings account. Buy and keep up adequate life insurance.** This puts your dollars where they'll do you good.

**Buy more War Bonds.** Not just a "percent" that lets you feel patriotic, but enough so it *really* pinches your pocket-book.

If we do these things, we and our Government won't have to fight a post-war battle against collapsing prices and paralyzed business. It's *our* pay envelope. It's up to *us*.

## KEEP PRICES DOWN!

Use it up • Wear it out  
Make it do • Or do without

This advertisement, prepared by the War Advertising Council, is contributed by this Magazine in co-operation with the Magazine Publishers of America.

Diagrams for

# THE RADIO EXPERIMENTER

If you have a new Hook-Up, send it along; a pencil diagram will do. Be sure to include a brief description.

All diagrams and descriptions accepted and published will be awarded six-month subscription. Diagrams may be for receivers, adapters, amplifiers, etc. Send them to Hook-Up Editor, RADIO-CRAFT, 25 W. Broadway, New York City 7.

## ALL-WAVE PORTABLE

I employ this hookup in a battery portable I am now using. It has a number of distinct advantages. It uses one 1T4 and one double-purpose triode, the 1G6-G. It has no "C" battery. These points save space. The tubes use only 1.5 volts on their filaments and can be lighted by one or two flashlight batteries.

The set is easy to hook up and produces remarkable results. I am located 115 miles from the strong stations in New York City, yet at night I receive them with ample volume on the small magnetic speaker in the set.

The short wave coils, down to 19 meters,

all work fine, and regeneration is smooth and easy to control. Standard short-wave coils are used. Many times I have listened to the news from London on this set with no ground, and only about four feet of antenna wire.

In recent issues I notice that some of the readers want diagrams of simple sets with two stages of audio. I hope this circuit may be what they have in mind. I have experimented with different parts values, and these seem the best for me.

ROBERT W. L. MARKS.  
Hawley, Pa.

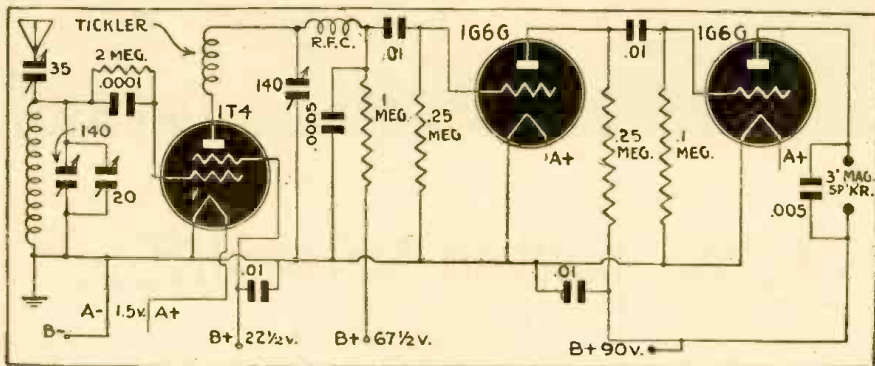

## CODE OSCILLATOR

The code practice oscillator shown below uses very few parts and is simple in construction. Feed-back is obtained in the push-pull transformer primary, while at the same time the speaker is matched through the

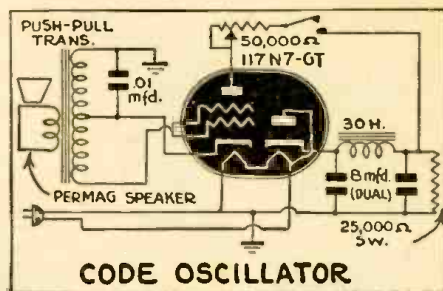

secondary winding. It can be seen that two purposes are accomplished in one transformer.

The values in the most part are not critical. By using the center-tapped transformer, we get a Hartley oscillator, one of the easiest to make go and most dependable of all. There is no trouble with the direction of the tickler winding on this oscillator, either.

This oscillator drove a four-inch speaker with enough volume to be heard throughout a large room.

RICHARD COLE,  
Canal Zone

## THREE-TUBE A.C.-D.C. SET

This diagram of a midget three tube T.R.F. receiver for 115 volt A.C.-D.C. operation uses two dual-purpose tubes, enabling the set to be more compact.

The 6K7-GT functions as a super-control R.F. amplifier, while the first section of the 6C8-G acts as a detector supplying the A.F. voltage into the second section for additional amplification.

The 25A7-GT is a combined output pen-

tode, and half-wave rectifier. A good 3-inch P.M. speaker will handle the output.

Careful construction and alignment of the trimmers on the 2-gang tuning condenser will give plenty of volume.

A ten-foot A.C.-D.C. antenna should be sufficient.

DOUGLAS KOHL,  
St. Charles, Illinois

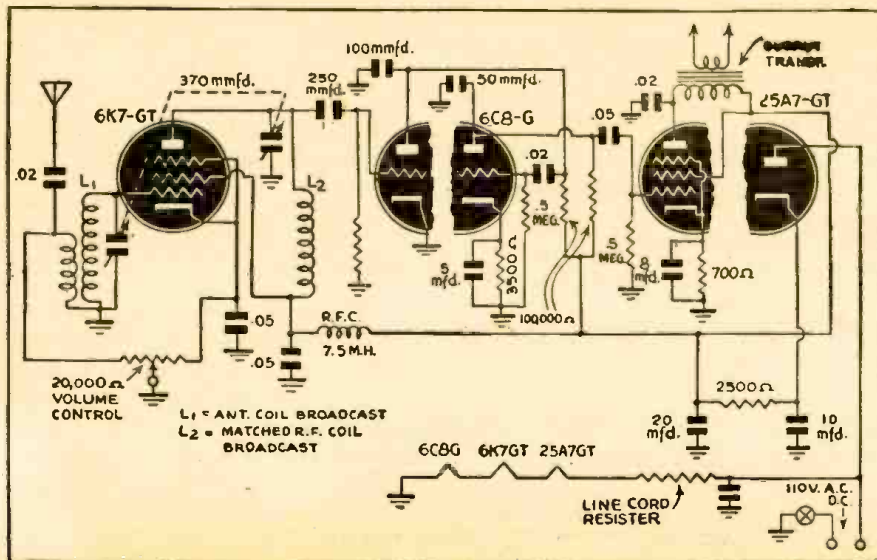

## SIMPLE SPEAKER EXTENSION

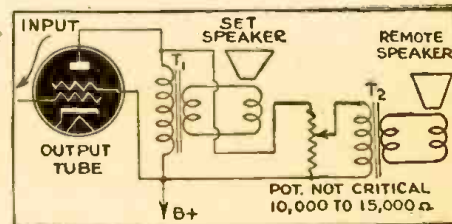

The above circuit has been used several times by me, and I find it very satisfactory. If a permanent magnet dynamic speaker is used only two leads from the radio will be necessary. A magnetic speaker works quite well, if the volume is not too great. This is even easier to hook up, as no extra output transformer is necessary.

I also find that using the potentiometer as shown, the volume of the extension speaker can be adjusted to the desired level without affecting the receiver speaker proper. Neither is there any noticeable decrease in receiver output when the extension speaker is connected. I have used this system with the additional speaker up to 70 feet away from the receiver with good results.

J. G. WILKINSON,  
Ottawa, Canada



**GRAB YOURSELF A COPY OF THIS BRAND NEW MANUAL BOYS! ITS JAM PACKED WITH DATA, CIRCUITS AND ALL THE SET INFO YOU NEED UP TO DATE OF GOVERNMENT SHUT DOWN APRIL '42.**

**Read These Facts!  
LOOK AT A COPY NOW  
See for yourself — COMPARE!**

**MORE LISTINGS:** This 1942 Radio Circuit Manual has nearly 400 more listings than the last edition of a similar manual. Covers receivers manufactured up to time of Government shut down order in April 1942. The set you're looking for here when you need it!

**MORE POPULAR SETS:** Listings of many popular set models are far more complete than in other manual recent edition. Check for yourself on such makes as Lafayette, Emerson, Pilot, Philco, RCA, Stewart Warner. This completeness will save you many times the cost of the book by saving your time enabling you to handle work more promptly.

**PERFECT DIAGRAMS:** There's nothing more annoying or costly than finding an incomplete circuit drawing. An artist carefully checked and retouched every diagram in the Radio Circuit Manual to make sure of PERFECT diagrams. The printing is clear, distinct, complete! You'll enjoy using this manual.

**MORE ON PAGE:** Ever had to fumble around turning pages because complete information didn't appear on one page? The Radio Circuit manual has big roomy pages which permit more complete data on a single page than any other manual. Another time-saver for you.

**HANDY SIZE:** The Radio Circuit Manual is thin, not fat, dumpy and bulky. This thin size and large page size makes it much easier to handle, easier to store

in a minimum of shelf space. The book lies open too, without pages flopping over so you have to hunt for your place again.

**QUICK REFERENCE INDEX:** The index in this manual is complete for both 41 and 42 editions. A big feature is the fact it tells you at a glance if a model is the same as another model number. No hunting back and forth, it's right there. Big readable page numbers and model numbers make for quick finding of what you want.

**SPECIAL REFERENCE CHARTS:** Special late edition charts on tube and battery interchangeability, pilot lights, ohms law, color codes. The information you often search for is here. Also a special article by F. L. Sprayberry to make your wartime service job easier.

**COMPLETE DATA:** The big pages feature not only Schematics, but quick reference IF spot, Parts Lists, Dial Stringing diagrams, tuning range and data, tube locations, voltage charts, trimmer locations, push button set-ups, alignment notes and procedures, record changer details.

Published By  
**RADCRAFT PUBLICATIONS, INC.**  
25 WEST BROADWAY,  
NEW YORK 7, N. Y.

**RADCRAFT PUBLICATIONS, INC., 25 WEST BROADWAY, NEW YORK 7, N. Y.** DEPT. RC 9-43  
 Gentlemen: Enclosed find my remittance of \$10.00 for which send me, POSTPAID, my copy of the RADIO CIRCUIT MANUAL—1942  
 Name \_\_\_\_\_ Address \_\_\_\_\_ City \_\_\_\_\_ State \_\_\_\_\_  
 (Send remittance in form of check or money order; register your letter if you send cash)

# RADIO KINKS

## HANDY RADIO "TROUBLE-LIGHT"

When making repairs or looking for defects this clamp-on light made from a spring clothespin lends an extra hand to the radio mechanic.

To prevent splitting the wood of the clothespin, first drill a small hole about half-way through before inserting screws. Be sure to use heavy bare wire for the coil around the base of the bulb.

The uses of this device are practically unlimited. The battery holder can be made to hold more than two cells if desired. Almost any convenient length of wire can be used between batteries and lamp. Flexible twisted cord is good.

G. BAGDY,  
Tonawanda, N. Y.

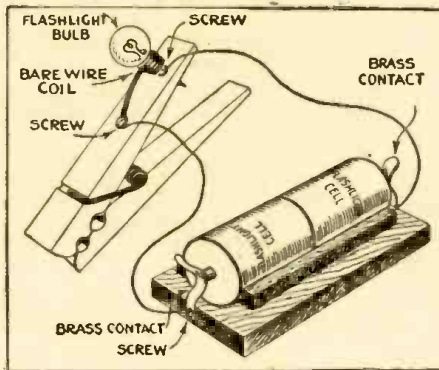

## CONDENSER TESTER

This is a diagram of a tester for condensers. It tests continuity and resistance from 0 to 10,000 ohms.

I have had very good results with this and trust that *Radio-Craft* readers will also have good results.

LONNIE ESTER,  
DeKalb, Illinois

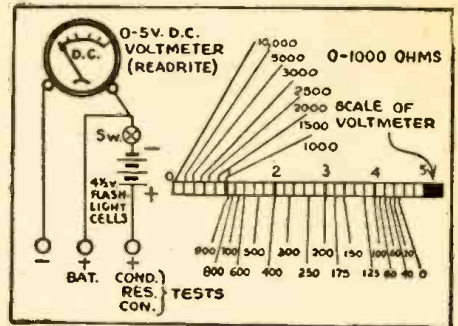

## "INERTIA" KNOB FROM OLD PIANO ROLL

Very attractive knobs, which look almost exactly like the "inertia" controls on communications receivers, can be made of an old player piano roll, a couple of old dial bushings and some plastic cement from the ten cent store.

As shown in the drawing, saw the rolls so that about an inch of the roll is left with the end. Now drill a 1/4-inch hole. This is to hold the set-screw of the dial bushing and to prevent slippage. Put the dial bushing in place, and turn the screw back so that it will project into the drilled hole.

Work the plastic cement in around the dial bushing, being careful to keep it properly centered in the new knob. In some cases it is advisable to put in some cement first and bed the bushing into it. Continue with the plastic cement till all the space is filled, including the drilled 1/4-inch hole.

These dials will give your set a professional appearance, and the improvement is well worth the little time spent in constructing them.

LAURENCE HANT,  
Flint, Michigan

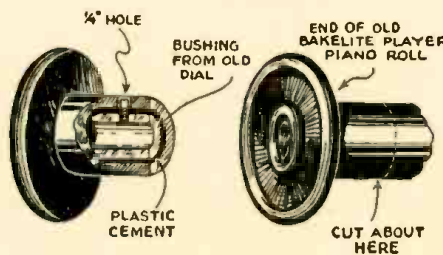

HOMEMADE "INERTIA" KNOB

## SHIELDED SCREWDRIVERS?

All small assembly operations in which fillister or round head screws are used can be facilitated by the use of a shielded screwdriver bit developed by F. Capello, a methods man at General Electric's Schenectady Works.

A standard straight screwdriver bit is used and the shield consists of a thin bushing which is pressed over the bit to completely shield the working surface of the screwdriver. This arrangement keeps the screwdriver centered on the screw and thus largely eliminates the possibility of burring the slot or slipping off the screw and thus marring the finished surfaces. This type of bit can be used in either manual or power-driven screwdrivers.

## BREAKLESS WINDER FOR CERAMIC COIL FORMS

An arbor which minimizes breakage of ceramic coil forms during the winding operation has been devised by A.C. Schlansker, foreman in the G-E Electronics Department. Breakage was a problem in the operation due to varying mechanical tolerances of the forms and the fact that the coils are wound under high tension.

Because of the hard, smooth nature of the forms, any jig which would hold them tight enough to prevent slippage created pressure enough to cause frequent breakage. The most convenient way to grip the coil is by pressure from within, but this is its most vulnerable axis. Use of soft rubber grips over a wide surface solved the problem.

The arbor consists of a square shaft which can be held in the chuck of the winding machine. Assembled on the shaft are alternate

metal and soft-rubber brass lined washers with a diameter slightly smaller than the minimum inside diameter of the ceramic form. When the coil form is slid over the winding arbor, a sliding cap which fits over one end of the square shaft is pushed against the stack of rubber and metal washers by a tailstock center device. The resulting compression of the rubber washers bulges their diameters, and they grip the inside surface of the ceramic coil.

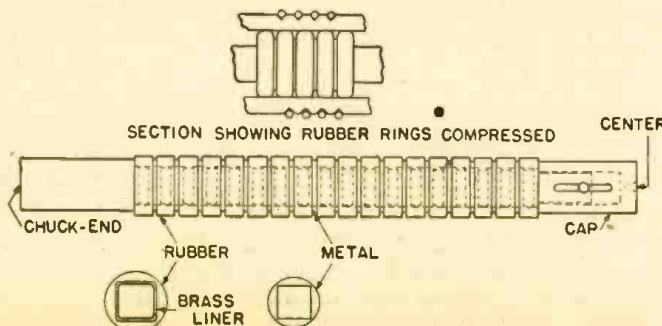

MINIMIZES BREAKAGE IN WINDING CERAMIC COILS

## SET TESTER

Following is a diagram of a very simple set tester which should be of interest to every beginner.

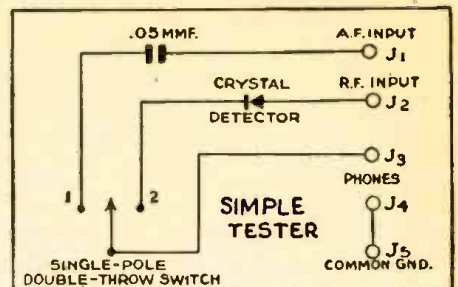

This tester in conjunction with a voltmeter makes servicing a very easy job.

With this tester radio troubles can be found and the defective stage isolated within a very short time.

As shown in the diagram this tester is made up of a fixed crystal detector, an .05 mfd. condenser, tip jacks, test prods, and headphones; all mounted on a bakelite panel 5 by 11 inches with a voltmeter and a milliammeter.

EDGAR BOLES  
Marion, Illinois

**OHMMETERS ARE HANDY**

*(Continued from page 733)*

ance should be above 20 megohms if the unit is in good condition. The leakage between the primary to core should also be above 20 megohms.

Many radio servicing beginners when attempting to check the secondary of a transformer such as 12, completely overlook the shunting effect of the voice coil. To test the secondary, disconnect one lead to the voice coil. Then put the ohmmeter across the secondary. The resistance may be very low, perhaps less than 1 ohm in some cases, so that a low reading ohmmeter should be used. The voice coil may have a resistance in the average radio of 3 to 8 ohms. In some special radios the resistance may range from 1 to 15 ohms but the first values are those most commonly found in everyday work.

**ELECTRIC PATHS LEAD TO—**

Looking at the diagram, you soon see one fundamental fact, that all of the plates and screens trace back to the rectifier cathode and all the cathodes of the amplifier tubes go to the on-off switch. There may be resistance in any path between two points. We must take resistance into account when making measurements, but these basic principles continue to apply.

The lead which comes off condenser 15 and goes to the on-off switch through choke 13 is a common wire or bus to which all the cathode circuits connect. We can check the cathode circuits rapidly by putting the ohmmeter on the negative terminal of Condenser 14C, and holding one prod on that terminal and shifting the other prod to the 43 cathode, 6B7 cathode, 78 I.F. and 78 1st det., 37 osc. cathodes. The resistance to the output, 2nd det. and I.F. cathodes should be zero or very low. The resistance to the 1st det. cathode is equal to that of part 2, 4000 ohms, to the 37 oscillator 500 ohms (part 1).

The resistance from the negative terminal of condenser 14C to the on-off switch may range from 30 to 500 ohms, in a typical set.

The rectifier cathode which supplies the plate and screen circuits of the 1st det., I.F., 2nd det. and oscillator tubes is connected to 14B.

**POINT-TO-POINT TESTS**

In working on a set it is often more convenient to use the condenser terminal as a starting point than to use the pin on a tube, though this is not always the case. In any event, we should have low resistance from the positive terminal of 14C to the first det. plate and I.F. plate. The resistance will probably be less than 15 ohms. If we find it is much higher, or infinitely high, we would look for an open circuited primary on transformer 32 or 33. We would also inspect the wiring to make certain a broken connection is not causing the trouble.

Obviously, in the case of the 2nd det., the resistance to the rectifier cathode will be high. It will be equal to the value of part 3, which is 250,000 ohms. Note that part 23 has a value of 250,000 ohms. If we connect an ohmmeter across condenser 15 and find that the resistance is less than 500,000 ohms we should immediately suspect a short or excessive leakage in 15.

Another point to notice is that the screens of the 1st det. and I.F. are tied together, as well as the plate return of the oscillator. Therefore, we can check by connecting the ohmmeter to the oscillator plate and the other side of the meter to the



**Keep 'Em Running FOR THE DURATION!**

It is difficult to secure new Generating Sets or new Rotary Converters . . . Pioneer is devoting all of its resources toward winning the war . . . but we can, and will, help you keep your present equipment running for the duration.

Send your service problems, by letter, to Pioneer's Customer Service Department.

DYNAMOTORS • CONVERTERS • GENERATORS • DC MOTORS • POWER PLANTS  
GEN-E-MOTORS

**PINCOR Products**

PIONEER GEN-E-MOTOR

CHICAGO, ILLINOIS • EXPORT ADDRESS: 25 WARREN STREET, NEW YORK CITY  
CABLE ADDRESS: SIMONTRICE, NEW YORK CITY

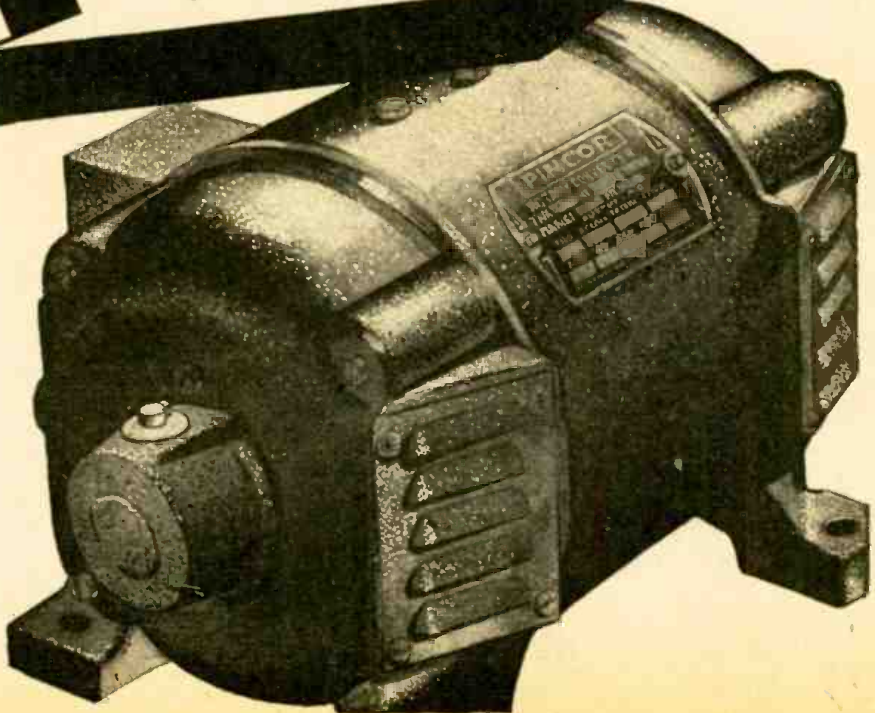

NEW

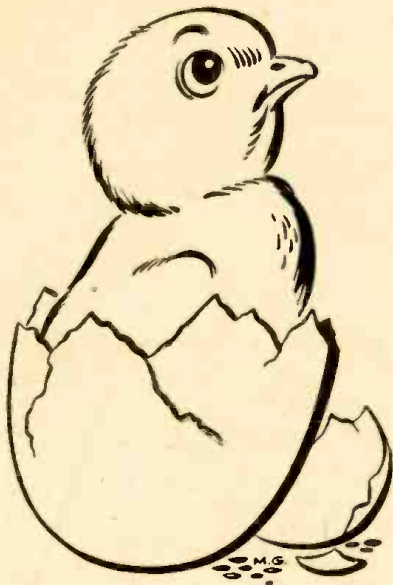

**T**HE new General Electric line of SERVICE TESTING EQUIPMENT, designed in the famous G-E Electronic Laboratory, provides an extensive choice of portable, compact apparatus suited for accurate, rapid maintenance and testing work in the field or service shop.

For testing radio and electronic circuits and component parts, these modern G-E unimeters, tube checkers, audio oscillators, oscilloscopes, condenser resistance bridges, signal generators, and other utility test instruments assure you accurate, dependable service. Planned for easy, error-free reading, the units are sturdy, stable, shock-resistant and compact.

G-E testing equipment is now in production primarily for the Armed Forces, but it may be purchased on a priority if you are engaged in war work. After the war, the full line will again be available to everybody.

... Electronics Dept., General Electric, Schenectady, N. Y.



**ELECTRONICS DEPARTMENT**  
**GENERAL ELECTRIC CO.**  
 Schenectady, N. Y.

Please send, without obligation to me, the General Electric Testing Instrument Catalog, R-1 (loose-leaf), for my information and files.

Name \_\_\_\_\_  
 Company \_\_\_\_\_  
 Address \_\_\_\_\_

**GENERAL ELECTRIC**  
 177-31  
**ELECTRONIC MEASURING INSTRUMENTS**

screen of the 1st det., then to the screen of the I.F. tube. The resistance should be less than 15 ohms, since we are measuring the resistance of the plate coil in the oscillator circuit.

The resistance from the oscillator plate to the rectifier cathode will be equal to the resistance of part 17A which has a value of 2500 ohms. The standard commercial tolerance is plus or minus 20% on resistors and any departure from the assigned value beyond that tolerance would call for replacement of the inaccurate part.

The resistance from the screen of the 78 1st det. to ground can be checked simply by putting the ohmmeter between the screen and the low side of resistor 2 in the cathode circuit. The resistance should be equal to the value of part 17B—12,500 ohms. The lead of 17A may be disconnected from B plus when making this measurement to avoid the shunting effect of the condensers in the power supply system.

**SHORT CIRCUITS AND SHORT CUTS**

In some cases a short circuit will develop between the primary of 32 and the secondary. The B plus and plate wires of the primary can be disconnected and an ohmmeter applied to one lead of the primary, the other side of the meter going to the grid of the 78 I.F. tube. The resistance should be higher than 20 megohms if the transformer is in good condition and does not have leakage.

With switch 26 open, to check the grid coil 29A and the secondary of 32 we can make a single, quick measurement between the grid cap of the 1st det. and the grid cap of the I.F. The resistance should be low, not more than 50 ohms.

To check condenser 6 we can connect an ohmmeter across it. The resistance should be greater than the combined resistance of part 24 and part 22. The total resistance of these parts is about 1.61 megohms. If our measurement shows the resistance across 6 is less than 1 megohm we should suspect the condenser and remove it from the circuit to have it checked. One lead to 6 can be unsoldered and the ohmmeter applied to the condenser terminals. Resistance should be above 20 megohms if the condenser is in good condition.

Note that the tuning condenser in the 1st det. grid circuit goes to the common ground or to 15. We can easily check the tuning condenser for a short by putting an ohmmeter across its terminals. The resistance should not be less than 1.61 megohms.

Contrast this with the necessity of removing the shunt coil from the tuning condenser in the I.F. circuit when the capacitor is to be tested for leakage or a short. The shunting effect of a coil across a tuning

condenser is also found frequently in A.C.-D.C. sets of the midget, T.R.F. type.

The filaments are not shown in the drawing, but may be checked very easily. It is usually convenient to pull the rectifier tube out of its socket and then to check the resistance between the plate and filament to determine whether the ballast tube or line cord resistor is burned out. You can also measure the resistance across the terminals of the electric plug of the radio. It should be slightly higher than the ballast resistance, since the tube filaments have a very low resistance when cold. The stress and strain due to expansion and contraction is one basic cause of short tube life.

In this discussion we have pointed out some of the ways in which a serviceman can check a receiver. You have seen how it can be done. The way you choose to do it is your own business, and you will probably develop your own and individual techniques. It will be part of your stock in trade—servicing ability or the power to analyze with instruments.

**Parts List for Reference**

- 1—500 ohm 1/4 watt resistor
- 2—4000 ohm 1/2 watt resistor
- 3—250,000 ohm 1/2 watt resistor
- 4—150,000 ohm 1/2 watt resistor
- 5—500,000 ohm 1/2 watt resistor
- 6—.1 mfd. 100 volt paper condenser
- 7—Antenna wire
- 8—.00051 mfd. mica fixed condenser
- 9A, 9B—500,000 ohm volume control line switch, in one unit
- 10A—(Used in Model 111) Power cord and plug including filament series resistor
- 10B—(Used in Model 115) Power cord and plug including filament series resistor
- 11—Two gang variable tuning condenser
- 12—Output transformer on 217-A speaker
- 13—Filter choke assembly
- 14A—4 mfd., 3 section 150 volt dry electrolytic
- 14B—13 mfd., 3 section 150 volt dry electrolytic
- 14C—7 mfd., 3 section 150 volt dry electrolytic
- 15—.02 mfd. 600 volt paper fixed condenser
- 16—.004 mfd. 600 volt paper fixed condenser
- 17A—For Model 111, 2500 ohm 1 watt res.
- 17B—For Model 111, 12,500 ohm 1/2 watt res.
- 17A—For Model 115 only, 2500 ohm 1 watt res.
- 17B—For Model 115, 12,500 ohm 1/2 watt res.
- 17C—For Model 115 only, 20 ohm ballast res.
- 18—Field coil and housing for 217-A speaker
- 19—Diaphragm, voice coil, shell and spider assembly
- 20—.25 mfd. 100 volt paper fixed condenser
- 21—.5 mfd. 100 volt paper fixed condenser
- 22—510,000 ohm 1/4 watt resistor
- 23—260,000 ohm 1/2 watt resistor
- 24—1.1 meg. 1/2 watt resistor
- 25—.0001 mfd. mica fixed condenser
- 26—Short wave switch
- 27—.01 mfd. 600 volt paper fixed condenser
- 28A, 28B—Short wave coil, short wave coupling condenser, in one unit
- 29A, 29B—Antenna coil, oscillator coil, in one unit
- 30—Pilot bulb (6.3 volt). Used on Model 115 only. (For Model 115 only.) Power cord and plug including filament series resistor. See part No. 81942 for Model 111. For Model 115 only, 2500 ohm 1 watt res., 12,500 ohm 1/2 watt res., 20 ohm ballast res.
- 31—.05 mfd. 100 volt paper fixed condenser
- 32—1st I.F. transformer with trimmers
- 33—2nd I.F. transformer with trimmers
- 34—12 mfd. 100 volt dry electrolytic condenser

**CAPACITESTER FOR DYNAMIC CHECKS**

(Continued from page 734)

plate circuit of the 6F5 tube is opened, allowing the other circuits to operate normally again.

**CONSTRUCTING THE CHECKER**

The construction of this unit is not at all difficult. In the unit described nearly all the parts used were salvaged from discarded radios. A much nicer looking tester could be made by using a metal cabinet, crackle finished, etc., but with the present conditions this is rather hard to do. If the constructor follows the basic design carefully and uses new or serviceable parts the tester will operate correctly regardless of its external appearance.

A chassis nine by twelve inches was used.

A panel twelve by eight inches is mounted on one side with the indicator tube located in the upper center, the gain control and A.C. switch on the lower left and the locking switch on the lower right. The pin tip jacks are mounted one pair on each side. The oscillator and radio frequency amplifier coils are ordinary solenoid broadcast coils with the primary windings removed. The oscillator coil is tapped two thirds of the way down from the grid end for the cathode connection. Two holes were drilled in each coil form, an eighth of an inch apart and a quarter inch below the bottom of the winding. A single turn of hookup wire was wound here and cemented in place, with the ends threaded through the

holes and leading out the bottom of the coil form and shield can in which each coil is mounted. A 15 mmfd. mica trimmer condenser is connected across each of the larger windings and a hole drilled in each shield can opposite the trimmer screw to permit the coils being tuned to the same frequency. A screwdriver is used for the tuning.

The frequency used does not have to be exactly 1800 kilocycles, any frequency near this will be satisfactory, preferably the highest one to which both coils will tune accurately. The two shield cans containing the coils are mounted under the chassis three inches apart and the link coupling turn leads are fastened in place by means of tie points. The constructor can place the rest of the parts to suit himself, providing the oscillator and the tuned circuit are so arranged there will be no interaction with the link coupling circuit open.

On the opposite side of the link circuit connected to the pin tip jacks, the circuit is again broken and a one tenth mfd. condenser inserted. This enables continuity or voltage tests across the condenser being tested simultaneously with the quality test. A small condenser is connected from one side of the pin-jack circuit to ground. This prevents any radio frequency pickup due to capacity between the larger winding and the link coupling turn. This tip-jack should be marked and used as the ground potential side of the test leads. The link coupling circuit is isolated from ground except for this small condenser so voltage or continuity checks can be made across the condenser under test or from either side of it to ground. The rest of the circuit is wired conventionally, using new or salvaged parts. In either case the constructor will have an instrument that will find a welcome place in any radio shop.

**CORRECT TESTING PROCEDURE**

To place the unit in operation, allow the tubes to heat for about 15 minutes. Connect a jumper across the pin-tip jacks or clip the test leads together, making sure the locking switch is in the (off) position. Advance the gain control until the indicator tube shadow starts closing. Accurately tune the oscillator and radio frequency amplifier circuit by means of the screwdriver trimmer condensers to the highest frequency to which both will respond. This peak will be indicated by the degree of closing of the indicator tube shadow. The process will have to be repeated several times, reducing the gain control each time the indicator tube shadow closes completely until the point of sharpest tuning is obtained.

When this is reached the testing portion of the instrument is complete. Now adjust the locking circuit as follows: With the link coupling circuit still closed advance the gain control until the indicator tube shadow just comes together. Close the locking switch, if the indicator tube shadow opens it indicates too much plate voltage on the 6F5 tube. This will have to be reduced until closing the switch has no effect on the indicator tube. This can be done by placing a small load on the secondary of the audio transformer by means of resistors placed across it or by a potentiometer across the A.C. line with the primary of the audio transformer connected to one side of the A.C. line and the center tap of the potentiometer. Whichever method is used, adjust the voltage until closing the locking switch no longer affects the indicator tube. When this point is reached, open the link coupling circuit momentarily and then close it again. If the unit is wired correctly the indicator tube shadow will open and remain so indefinitely until the locking switch is turned off.

**HOW TO USE THE INSTRUMENT**

There are only two controls, the R.F. amplifier gain control and the locking switch. Heat the tubes to operating temperature, hold the test prods together and adjust the gain control until the indicator tube's shadow just closes. Plug an ohmmeter or voltmeter, depending on whichever method you prefer, in the two extra pin-tip jacks provided for this purpose and proceed to check the condensers in their circuit, remembering to use the prod so marked on the ground potential end of the circuit. An open condenser will be indicated by the indicator tube's shadow refusing to close completely and in most cases by refusing to move at all. The operator of this unit can familiarize himself with its operation by making tests of combinations of various sized resistors and condensers in parallel, noticing the shadow positions with

the condenser in and out of the circuit.

If a condenser is suspected to be intermittent the test leads should be clipped across it and the condenser squeezed with the fingers or tapped with a rubber tube tapper or similar instrument. If the condenser makes and breaks contact due to this treatment it will be shown by the indicator tube's shadow blinking or opening. To test a condenser over a period of time, the leads are clipped across it and the locking switch closed. If the condenser open circuits at any time the locking tube will keep the indicator tube's shadow open, showing the condenser to be intermittent. A shorted or partially shorted condenser will be shown by the discrepancy of the ohmmeter or voltmeter reading in comparison with the circuit diagram or voltage chart. This makes a very handy combination; both a condenser quality check and a point to point

**WHEN THE LIGHTS COME ON AGAIN**

# AUDIOGRAPH

THE FIRST NAME IN SOUND

When our thoughts turn to praise for blessings instead of prayers for Victory, Audiograph will find its place, as a gratifying acoustical aid. Audiograph is one of our Family of Activities in the field of electronics—a field destined for service to man.

**JOHN MECK INDUSTRIES**  
PLYMOUTH, INDIANA

EXCELLENCE IN MUSIC AND VOICE REPRODUCING INSTRUMENTS

# TEST INSTRUMENTS

FASHION NOTES

## SYLVANIA SERVICEMAN SERVICE

by FRANK FAX



### SAVE YOUR SUITS — WEAR SYLVANIA WORK CLOTHES

This service coat is a knee-length, double strength herringbone-weave dungaree. Roomy pockets at arm's length. Can be buttoned far down the front to protect street clothes. Available in sizes 36, 38, 40, 42 and 44. Price each: \$1.95.



This service apron, made of heavy green duck, has three tools-and-parts pockets. Just the thing to impress customers with your efficiency and neatness. Buy several, so you'll always have a clean one. Price: only 25 cents



This service jacket is made of the same tough material as the service coat. Single-breasted, three large pockets, full-length sleeves. Just as suitable for shop wear as service calls. Available in sizes 36, 38, 40, 42 and 44. Price: \$1.75



Order from your Sylvania Jobber or direct from Frank Fax, Department RC-9, Sylvania Electric Products Inc., Emporium, Pa.

**SYLVANIA** ELECTRIC PRODUCTS INC.  
RADIO DIVISION

resistance or voltage reading simultaneously, using the ohmmeter or voltmeter already in the shop.

In some instances it may be necessary to insert a low resistance radio frequency choke in series with the pin-tip jacks used for the meter connection, but in most cases it will be found the meter movement has enough reactance in itself that it will not move the tuning indicator shadow when connected to this instrument. This condenser tester does not indicate the capacity of electrolytic condensers. The capacity of paper and mica condensers is either marked on them or the circuit diagram, and does not vary with age or use as with the electrolytic ones. This instrument will check electrolytics for radio frequency reactance and will pick out a defective one that may be causing radio or audio feedback due to common coupling in the filter circuit. In most cases where the electrolytic condenser checks OK for capacity and is still operative in its filtering action a mica or paper condenser placed in parallel with it will cure it temporarily until a new one can be obtained.

In checking plate to grid coupling condensers after making the quality test it is always a good plan to test the condenser for leakage by means of a vacuum tube or high resistance voltmeter placed across the grid leak of the amplifying tube while the set is in operation and no signal tuned in.

If any voltage is present it indicates either a leaky coupling condenser or a gassy tube.

This brief outline, plus a few minutes use of this instrument will prove its ease of operation and value in speedy servicing.

#### List of Parts Used in Condenser Tester

##### RESISTORS

- R1—15,000 ohms, 1/2 watt
- R2—25,000 ohm potentiometer with A.C. switch
- R3—500,000 ohm, 1 watt
- R4—2 Meg., 1 watt
- R5—1 Meg., 1 watt
- R6—30,000 5 watt ww.
- R7—13,000 5 watt ww.

##### CONDENSERS

- C1—15 mmfd. mica trimmer, screwdriver type
- C2—0001 mica
- C3—0005 mica
- C4—.05 600 V. tubular
- C5—.01 400 V. tubular
- C6—.1 400 V. tubular
- C7—.1 600 V. tubular
- C8—.006 600 V. tubular
- C9—8 mfd. 450 V. electrolytic
- C10—.02 600 V. tubular

##### MISCELLANEOUS

- CH1—2.5 MH RF Choke
- CH2—30 HY Filter Choke
- L-1/L-2—Solenoid BC coils per text
- V1—76
- V2—6B7
- V3—80
- V4—6F5
- V5—6E5
- T1—5-Tube BC Power Transformer
- T2—3:1 Audio Transformer
- 4 Pin Tip Jacks, Tube Sockets, Misc. Hardware, Hookup Wire, Solder, etc.

## RADIO WAVES AND RADIO ANTENNAS

(Continued from page 729)

frequency, the CURRENT is MAXIMUM at the CENTER, and ZERO at the ENDS, while the VOLTAGE distributes itself in just the opposite manner, being maximum at the ENDS and ZERO at the CENTER.

We have shown this with R.F. ammeters and with neon lamps, and have even digressed into the dangerous territory of crude mechanical analogies—vibrating rubber bands and steel strips—in a desperate attempt to present a difficult subject in simple terms. We are now ready to present the method used by radio engineers to represent ( . . . I said REPRESENT ) these standing wave current-voltage relations.

In Fig. 3-C let AB represent our antenna. Then the solid curved line represents the maximum values attained by the current at any and all points along the wire, and the curved broken line represents the maxi-

mum values attained by the voltage at any and all points along the wire. Here again we have a mere REPRESENTATION—It must be remembered that the current and voltage are really in or on the wire itself, not looping about in the space above it! The curves merely represent their HIGHEST VALUES at points along the wire.

#### GENERATION OF RADIO WAVES

Let us now consider Fig. 4. We have shown (Fig 4-B) a transmitter connected to a simple vertical radiator and to Earth. Let us imagine for convenience that the transmitter is delivering R.F. current to the radiator at its natural frequency.

Let us study the field phenomena as the antenna current alternates.

(1) Suppose we start with voltage and current relations as at Fig. 4-A, where the

Fig. 5—Current values along wires resonant at 1/2, 1 1/2 and 3 1/2 wavelengths respectively are shown at A, B, C and D. The corresponding radiation patterns are represented by E, F, G and H, and are theoretical diagrams based on the assumption that the wires are to be suspended in free space.

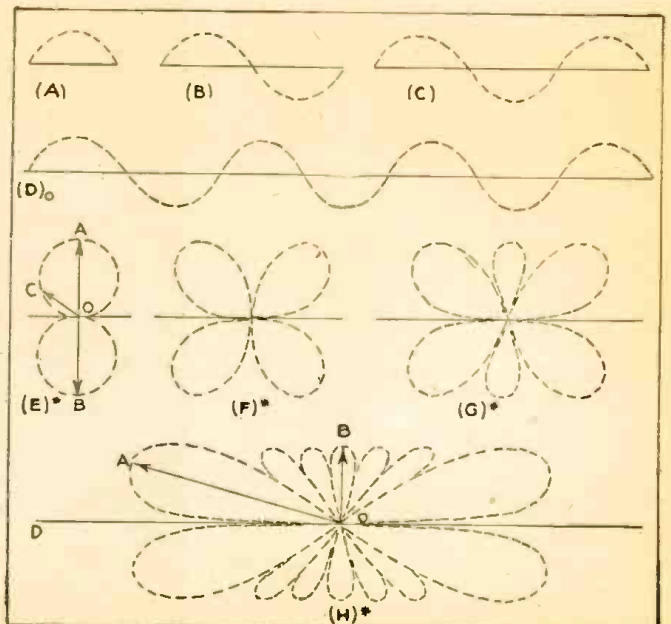



voltage (represented by the *broken* line) is maximum positively, while the current (represented by the *solid* line) is zero.

When conditions are such in the antenna (Fig. 4-B), *electrostatic* lines of force will exist between the antenna and the earth by virtue of the capacitance (Fig. 1-B) between these two bodies just as they would between any two bodies at different potentials with respect to one another. Let us assume that the lines of force are in the direction indicated by the arrows.

(2) Now, as the voltage progressively drops (A to C, Fig. 4), the *electrostatic* field will tend to collapse back onto the antenna, and as the current progressively rises an *electromagnetic* field will come into existence around the wire just as is the case with any wire carrying a current. This field **INCREASES** with the current until—

(3) As in Fig. 4-D, the voltage has dropped to zero with an accompanying disappearance of the *electrostatic* field, and the current has risen to a maximum (positively) with a corresponding maximum intensity of the *electromagnetic* field, the lines of force of which travel, let us say, as indicated by the arrows (Fig. 4-D).

(4) Now the **CURRENT** begins to dwindle (C to E, Fig. 4) and the complimentary *electromagnetic* field tends to collapse onto the wire (Lenz's Law—Remember?). Meanwhile, the **VOLTAGE** is coming into its own again, although in opposite (i.e., *negative*) polarity. This re-invokes the *electrostatic* field which increases as the voltage increases and as the *electromagnetic* field decreases, until—

(5) At F of Fig. 4, the current has dropped to zero, the *electromagnetic* field collapsed, the voltage attained the *negative* peak, and the *electrostatic* field is at maximum—this time, however, in the opposite direction, as shown by the arrows.

(6) Now the process continues until (G) the current is maximum negative and the voltage zero again. The negative *electrostatic* field has collapsed and the negative *electromagnetic* field, which has been progressively increasing, has reached its maximum. (Note that the arrows are in a direction opposite that of Fig. 4-D.)

(7) The process now continues until the voltage and current are in the same respective phases as when we commenced our little investigation (Figs. 4-I and 4-J).

The important things to note about all this are:

(1) An alternating *electromagnetic* field has been established in the vicinity of the antenna by virtue of the alternations of the R.F. **CURRENT** fed to the antenna by the transmitter.

(2) An alternating *electrostatic* field has been established in the vicinity of the antenna by virtue of the alternations of the R.F. **VOLTAGE** applied by the transmitter.

Notice that the *electrostatic* lines of force lie in the same planes as the antenna, existing all around a vertical antenna and the Earth or **BETWEEN** a horizontal antenna and the Earth, while the *electromagnetic* lines of force lie in a plane perpendicular to the antenna. Thus the two fields are perpendicular also to one another.

**INDUCTION AND RADIATION FIELDS**

Now if the frequency used in the preceding considerations were *low*—say somewhere in the audio range or a little higher—most of the *electrostatic* and *electromagnetic* lines of force would have time to collapse back onto the antenna as (respectively) the voltage and current decreased to zero.

However, this appears to be far from the case when we apply currents at **RADIO** frequencies to the wire. In this case, the current and voltage change polarity so quickly, many thousands of millions of times a

second, that long before the field created by a given alternation has had time to collapse back into the wire, the succeeding field has already come into existence and is rapidly waxing!

Herein lies the whole secret! Here is the phenomenon which makes radio communication possible!

That small portion of the field which never gets out of the vicinity of the antenna and which largely collapses back onto the antenna when the current or voltage wanes is termed the **INDUCTION FIELD**. The *electromagnetic* **INDUCTION FIELD** is exactly analogous to the fields existing about ANY wire carrying low-frequency **CURRENT** (the 110-Volt house wiring, for instance), and the *electrostatic* induction field is analogous to the fields existing between ANY two wires or other bodies between which a difference of **VOLTAGE** exists.

But the rest of the field—the part which

is left outside high and dry and has no time to return to the wire—*somehow* leaves the vicinity of the antenna and goes on out into space. This is the **RADIATION FIELD**.

The radiation field, then, consists of two components at right angles to one another, the *electrostatic* field—occupying a plane **PERPENDICULAR** to the earth if **VERTICALLY** polarized (i.e., if emanating from a **VERTICAL** antenna) or occupying a plane **PARALLEL** to the earth if **HORIZONTALLY** polarized—and the *electromagnetic* field—occupying a plane **PERPENDICULAR** to the plane of the *electrostatic* field, whatever that may be.

The *electrostatic* field, of course, becomes weaker and weaker—is *attenuated*—as the distance from the antenna increases. Its intensity decreases **DIRECTLY** as the distance increases. Thus if it has a given intensity, say "X," at a certain distance from the transmitter, at **TWICE** that distance

**Immediate Delivery on Meissner Iron Core I.F. Transformers**

No. 16-5740  
frequency range  
360-600  
(456 kc. input)

No. 16-5742  
frequency range  
360-600  
(456 kc. output)

Price \$2.20 each

**Designed primarily as original parts in high-gain receivers of superior quality... Wide frequency range and greater selectivity permit almost universal application for replacement use... all units are double-tuned with ceramic base. Mica-dielectric trimmers, windings are of high grade Litz wire, thoroughly impregnated. Black finish shield 1 1/8" square by 3 1/2" high.**

**Meissner**  
MT. CARMEL, ILLINOIS

**"PRECISION-BUILT ELECTRONIC PRODUCTS"**

**THE PEACETIME  
MEASURES OF  
REFLECTION AND  
DEFLECTION . . . .  
WILL BE READ FROM**

**TRIPLETT**

**ELECTRICAL MEASURING INSTRUMENTS**

**WITH CONFIDENCE  
AND ECONOMY**

THE TRIPLETT ELECTRICAL INSTRUMENT CO., BLUFFTON, OHIO

**BACK UP YOUR BELIEF IN AMERICA...BUY WAR BONDS**

its intensity will be  $\frac{1}{2}$  X; at FOUR times the distance it will be  $\frac{1}{4}$  X; at TEN times the distance it will be  $\frac{1}{10}$  X; etc.

The electromagnetic component becomes attenuated at a much greater rate, its intensity varying INVERSELY as the SQUARE of the distance. Thus if its intensity is "X" units at a given distance, at TWICE that distance it will be  $\frac{1}{4}$  X; at FOUR times that distance it will be  $\frac{1}{16}$  X; at TEN times the distance it will be  $\frac{1}{100}$  X; etc.

It seems likely that as the electrostatic field progresses, it emits an electromagnetic field of its own, and that it is this electromagnetic field which induces the feeble currents in receiving antennas which are amplified and reproduced.

Most of us know, of course, that these radio waves travel at a velocity near 186,000 miles or 300,000 kilometers a second.

The exact manner in which these radio waves progress through space is unknown. Earlier radio-physics texts elaborated at great length as to how certain "vibrations" in a "hypothetical medium" known as the "ether" constituted the agency through which propagational phenomena occurred. But the "ether" in this particular connection seems to have fallen into discredit.

Radio-physicists are now attempting, with a considerable measure of success, to explain these phenomena on a basis of the relatively recent Quantum Theory, the general idea being, in a word, that the electrostatic field distorts or strains the shapes of the electron orbits of the atoms and molecules of the gases constituting the air as it passes on through space, and when these "strained" orbits "relax" into their normal positions again, electromagnetic radiations are produced, these inducing the antenna currents in the receiving antennas in the neighborhood.

#### RADIATION PATTERNS

Several good questions have possibly occurred to the reader: "How do these waves go out from the antenna? In all directions, or are they restricted to just certain directions? Do they go up in the air, or just along the ground?" etc.

In Figs. 5-A, -B, -C, and -D are shown CURRENT distributions of antennas resonant at, respectively,  $\frac{1}{2}$  wavelength, a full wavelength,  $1\frac{1}{2}$  ( $\frac{3}{2}$ ) wavelengths, and  $3\frac{1}{2}$  ( $\frac{7}{2}$ ) wavelengths, and directly under each (Figs. 5-E, -F, -G, and -H) is the RADIATION PATTERN for (respectively) the antenna current conditions shown in Figs. 5-A, -B, -C, and -D.

In other words, for an antenna with a standing wave as shown in Fig. 5-A, the RADIATION PATTERN would be like a figure "8" as in Fig. 5-B. This "8" is 3-DIMENSIONAL! The reader should imagine Figs. 5-E to 5-H (inclusive) rotated around the line representing the antenna as an axis. This will give a toroidal ("dough-nut") shape to the figure "8" of Fig. 5-E.

The significance of these patterns is as follows:

The radiation in a given direction is proportional to the distance from the center of the antenna to the periphery of the radiation pattern for the antenna. Thus, in Fig. 5-E, radiation in directions OA or OB ("broadside") will be maximum, while radiation intensity will decrease toward either end until in directions like OC, for instance, it is of low intensity, and in direction OD ("end-on") it is practically zero. Thus a HALF-WAVE antenna transmits MAXIMUM radiation in directions PERPENDICULAR to it, and MINIMUM (almost zero) toward its ENDS.

With the  $\frac{3}{2}$  wavelength antenna (Fig.

5-H) however, radiation in direction OB is far less than in direction OA. This may be interpreted into an important generalization as follows: As the number of half-waves standing on a radiator increases, the radiation becomes more and more intense toward the ends and less and less intense at right angles to the wire.

Perhaps now it may occur to the reader why so many transmitting stations use VERTICAL antennas. If the half-wave antenna in Fig. 5-E is placed on its END the figure "8" (- - - i.e., the 3 dimensional toroid) will be on its SIDE, that is to say, MAXIMUM radiation will not be emanated ALONG THE SURFACE OF THE EARTH instead of straight UP into the air or DOWN into the ground.

We now have sufficient basis to proceed to our main topic—PROPER, which will appear in the next issue, but we cannot urge too strongly that if the reader does not fully grasp the facts thus far set down, he should re-read the article thus far.

Wave propagation is an important phase of the science of Radio-physics, and the writer firmly believes that the reader who "gets" this article will be in a good position to read and understand the chapters on wave propagation in the regular engineering texts (with, of course, the exception of those parts treating the higher mathematical aspects of the subject).

#### REPAIRING AC METERS

(Continued from page 723)

may be adjusted by spacing the turns.

FRICION. Dull pivots can be sharpened by removing the moving element from between the bearings. This is done by first unsoldering the top spring connection from the zero adjuster fork and removing the two bridge and damping box cover screws. The moving element may then be examined carefully for dirt and dullness.

If the pivots show signs of dullness, they may be sharpened with a small stone and cleaned with alcohol. The jewels can be cleaned with alcohol and a small stick sharpened to a point, as explained in the articles on repairing D.C. meters.

Examine the damping vane and box for signs of dirt or chips. Make certain that the vane is square and does not contact the walls or cover of the damping box at any point.

If the trouble is in the series resistor, it should be replaced by one of the correct resistance and wattage.

In some cases it may be possible to repair the series resistor by rewinding a new spool in a manner similar to that described above for the field coil. Resistance wire similar to that used for D.C. meters may be employed for this purpose. In general, the series resistor spools for A.C. voltmeters are required to dissipate considerably more power than those in a D.C. meter.

The fine wire series resistors may be protected from moisture by boiling in a high-melting-point wax until all signs of bubbles have disappeared. After the spool has been removed from the wax, clean off the outer surface to make certain there is no chance of the wax getting into the moving element, should it melt in service.

Once an A.C. meter is repaired, it must be checked and adjusted for balance in the same manner as a D.C. instrument.

The end play of pivots and jewels should be adjusted to be approximately 50% greater than in direct current instruments, or a maximum of approximately 0.0075 inch. This is to allow for the greater degree of expansion and contraction of the bakelite supports under changes of humidity and temperature.

**OUTPUT TRANSFORMERS**

(Continued from page 726)

winding a 1- or 2-turn secondary and making the primary to match? Does the secondary have to have the same resistance as the speaker voice coil? An ohmmeter will show that this is not the case. The usual "2-ohm" voice-coil winding on the transformer will have a resistance considerably less than 1 ohm, in some cases so small as to be hard to measure at all.

The primary is our reason for having a large number of turns. So far, we have been talking as if the impedance of a transformer with an open secondary is infinite. This is not so; a certain amount of current passes and a little power is used up in the best transformer. We want to make that primary impedance big enough so we can ignore it, in comparison to the reflected impedance from the voice coil. This is done by using as many turns and as much iron as is economically practical.

Since the impedance of our transformer primary is largely due to its inductance, it will be at its lowest at the low frequencies. At such frequencies it will then offer a lower-than-normal load to the plate, and low-frequency signals will be correspondingly weaker. In actual practice, a compromise has to be made between efficiency on the one hand, and size and cost on the other. Even the best transformers begin to drop off a little, and one that would pass equally well all frequencies down to the low audio limit of 16 cycles would be a laboratory curiosity. On the other hand, some cheap transformers have so little inductance as to reproduce practically nothing below 100 cycles.

A number of other factors enter into output transformer design. If the number of primary turns is increased to increase its inductance, the distributed capacity between turns increases to a point where the higher audio frequencies are by-passed, and we get a tone-control effect much the same as if we had connected a condenser between plate and cathode, or plate and plus-B. This is another place where compromises must be made.

Another important point is core size. The core must be made big, not only to increase the primary inductance, but to prevent "core saturation." The primary carries direct current, therefore the core is partly magnetized and has a field around it at all times. This has no effect on the secondary, as transformer action is a result of changes in the strength of a magnetic field. If we apply a 400-cycle note from a signal generator to the grid of our amplifier tube, the plate current will increase and decrease 400 times a second. On each increase the magnetic field will strengthen—on each decrease it will weaken. To the secondary it looks as if a 400-cycle alternating current had been superimposed on the direct current in the primary—and we get a 400-cycle note in the speaker.

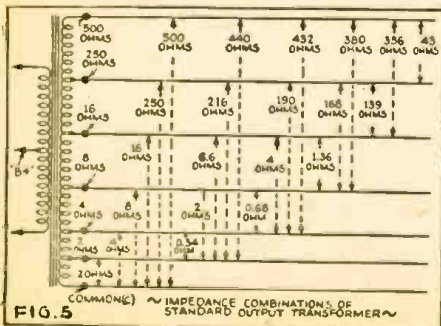

The multiplicity of different impedances in one universal output transformer are shown here.



# ONAN

## ELECTRIC PLANTS

Electricity for Any Job—Anywhere

★ ONAN GASOLINE DRIVEN ELECTRIC PLANTS provide electricity for all communications work in locations where it is not otherwise available, or for emergency and standby service. Thousands of these reliable, sturdy Plants are doing a winning job on all the fighting fronts, in communications and other vital war tasks.

We'll be glad to send details promptly on your present or post-war needs for Electric Plants.

**350 to 35,000 WATTS**  
 A.C. 50 to 800 cycles, 110 to 660 volts.  
 D.C. 6 to 4000 volts. Also dual A.C. and D.C. output models. Engines are air or water cooled. Model shown is from OTC series, air cooled.

**D. W. ONAN & SONS**

725 ROYALSTON AVENUE                      MINNEAPOLIS, MINN.

There is a limit to the magnetization of any iron, and if the transformer is small and the direct current large, the core may be entirely or almost entirely magnetized with no signal applied. Then any rise in current due to our 400-cycle signal would cause little or no increase in the magnetic field, while the decrease in current would have a normal effect. The loudspeaker would not get a faithful reproduction of the signal on the grid, and distortion would be the result. Such magnetic saturation of the core must be avoided by keeping it large. (This is another one of the reasons for poor reproduction in midget sets, which often have ultra-midget output transformers.)

The current in a push-pull transformer splits and flows both ways through the primary, the field set up by one half bucking out the field of the other half. Thus there is no direct-current magnetization in a push-pull transformer, and the problem of core saturation does not appear.

Laminations are usually placed the same as in a choke, as another attempt to avoid saturation. That is, all the "E" pieces are put in from one end and all the "butts" from the other. This unfortunately cuts down the inductance as well, but the good effects outweigh the bad.

As the average individual has no way of finding out the characteristics of the core iron he is working with, design of output transformers is largely a matter of allowing enough iron to be sure to be safe. This can be carried too far—a very big transformer, besides having too much distributed capacity, may produce such high voltages by self-induction as to continually break down tube sockets between the plate and screen-grid prongs. If a transformer is re-

(Continued on following page)

**GUARDING COMMUNICATIONS WHERE THE GOING IS TOUGH!**

# SUPREME

**TESTING INSTRUMENTS**

The famous 504-A and other SUPREME Testing Instruments are on active duty in all parts of the world. Now more ruggedly built, more accurate and dependable than ever, SUPREME Instruments will be your logical choice when victory is won.



**SUPREME INSTRUMENTS CORP. GREENWOOD, MISSISSIPPI**

## Headset Headquarters



Our Headphones are used by the United States, Canadian, New Zealand and South African Governments as well as other Governments not directly in the war. Folder C-9 illustrates rugged, unusually sensitive, dependable Cannon-Ball Headsets.

Scientifically Built Heavy bar magnets greatly increase their efficiency. Write.....

**C. F. CANNON COMPANY**  
 SPRINGWATER, N. Y.

**NOW WE HAVE "OPTI-ONICS"**

AS the word Electronics continues to grip the popular imagination, numbers of variations on the word spring up. The last two syllables are particularly easy to kidnap and have been utilized in a whole series of "onic" expressions.

Probably the very latest of these is "Opti-ronics," a term coined by Mr. J. H. McNab, president of Bell and Howell Co., to describe work in which electronic and optical engineering overlap or supplement one another.

# •SERVICING•



Switch SW-141

## Voice Communication Components



Plugs PL-54 and PL-55



UNIVERSAL high quality plugs, jacks and switch assemblies have been made available to prime and sub-contractors for earliest quantity deliveries. Catalog No. 830 contains complete details.

### Universal Microphone Co. Ltd.

INGLEWOOD, CALIFORNIA

FOREIGN DIVISION  
301 Clay Street, San Francisco 11, Calif.  
CANADIAN DIVISION  
560 King St. W., Toronto 2, Ontario

quired for a new job, the best system is to use the primary of one already suited to the tubes, and wind a new secondary for the job on hand at any given time.

As an example, suppose the speaker of Fig. 1 is damaged and we want to substitute another with a 4-ohm voice coil. The impedance ratio is  $\frac{7,000}{4}$  or 1,750. The square

root of that is roughly 42, so our winding ratio should be about 42 to 1. The correct number of turns for the voice-coil winding is 71.

If it is desired to connect three 2-ohm speakers to the same output, it is an easy matter to rewind the transformer for the purpose. If the speakers are to be near the output, a parallel connection will probably be best, if some distance away, a series connection. (Here is one place where we think of voltages. For a longer wire, there will be less loss with higher voltage and smaller currents.) The number of turns for the 6-ohm connection is 88, for the 0.67-ohm parallel circuit, 29 turns. Voltages and currents should again be remembered in selecting wire. The higher impedance will use finer wire, on account of the higher voltage and lower current, while heavier wire must be used in the parallel circuit.

There is a warning here for persons using a multi-tapped transformer. The impedances between the 2- and 4-ohm taps of the unit we have just been considering, (supposing we were to bring out the two taps) are quite different. We have 50 turns for the 2-ohm winding, and 71 for a 4-ohm load. If we connect a 2-ohm voice coil between the 2- and 4-ohm taps, it will be across 21 turns instead of 50, and its impedance will actually be 0.34 ohm. Thus a large number of impedances may be obtained from a few taps. Fig. 5, reprinted from a *Radio-Craft* article by A. C. Shaney, indi-

cates how many different impedances can be obtained across half-a-dozen taps.

Before leaving the subject, it may be worth while to point out that the impedance-matching can be worked both ways. We have been speaking of our transformer from a viewpoint of a 7,000-ohm primary only. We can put it in the plate circuit of a tube with a 3,500-ohm load (some triode amplifier tubes require an output load in this order) and the 71-turn winding which was formerly a 4-ohm impedance now is suitable for a 2-ohm voice coil. The ratio of impedances remains the same.

The amateur designer should have little trouble in winding output transformers to his own specifications, if he first tears down a few for study. He will check the output impedance of the tube from the manual, and measure the voice-coil of the speaker with an ohmmeter. Then a careful count of the windings will enable him to make a sketch like that of Fig. 3. He will find that primaries run from 2500 to 4500 turns, and cores  $\frac{1}{2}$ -inch to 1 inch square, with odd exceptions even going beyond these limits. For safe design, it is good practice to follow that of the larger units studied. The smaller ones were probably made that way to sell at a low price. Wire size should be as large as possible, the limit being that the coil has to go back into that window. Core iron must be of good quality—use audio or output transformer cores.

Many transformers can be adapted—as heretofore explained—by simply unwinding the secondary, noting the number of turns, then calculating the probable number of primary turns from the impedance of the speaker voice coil and the tube output impedance as listed in the manuals. With a little common sense and intelligent calculation, transformers already lying around the shop may be made to do jobs for which new units would otherwise be required.

### FIXED BIAS AMPLIFIERS

(Continued from page 731)

tion of the speaker field coil for the resistor R1 of Fig. 4. By this connection we not only have a resistor in the negative return of the power supply, but we have combined field excitation, filter choke, and bias resistor—a saving of parts which is particularly desirable under present conditions.

The filter network to prevent the supply hum across the speaker field from reaching the audio grid presents no serious prob-

lems, although it should be remembered that no condenser should be connected directly from the hot side of the speaker field to ground, as this will in effect bypass power supply hum around the filter choke. If the resistance of the speaker field happens to be exactly the right value, the final stage's grid return may be made directly to its hot side through a filter network consisting of a  $\frac{1}{2}$  meg. or more resistor and a

Here we have real fixed bias at last. The 1-V forms an independent source of negative voltage, and grid potentials can be adjusted with the variable resistors R3 and R4, and are quite independent of any normal changes in voltage or current in the rest of the amplifier. Equipment for hum filtering and decoupling is cut to a minimum.

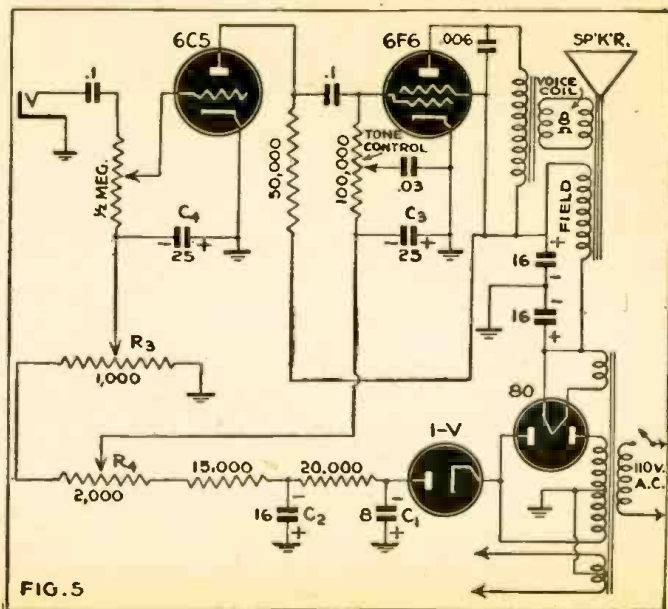

FIG. 5

25 mfd. or more condenser as shown in Fig. 4. This is sufficient to prevent ripple voltage from reaching the output grid, and the high value of the resistor, also practically eliminates any bypassing of the hum voltage around the speaker field. The 25 mfd. condenser should have as low a leakage as possible (a paper unit with a 400-volt rating is satisfactory) to prevent voltage drop through the high resistance of the 1/2 meg. filter. If the speaker field has a resistance higher than that required to produce the correct bias voltage, a resistor R1 will have to be added as shown in the figure. This forms a voltage divider to present the correct voltage to the grid return. It also shunts the speaker field with a resistance, but the value of this resistance is so high as to have a negligible effect on the filtering of the "B" voltage. The value of R1, if the bias filter resistor is 1/2 meg. and the .25 mfd. condenser has no leakage, is given by the formula:

$$R1 = \frac{500,000 e}{E - e}$$

where E is the D.C. voltage across the speaker field and e is the required bias voltage for the output tube.

(This formula also applies if the speaker field is of the correct resistance, since in that case

$E = e$  and  $R1 = \frac{500,000 e}{0} = \text{infinity}$ , i.e., no resistance R1 is used.)

This system not only has the advantage of eliminating parts, but also eliminates the second disadvantage of cathode bias entirely, for although the voltage drop across the speaker field prevents the full output of the rectifier from being used as "B" voltage, this drop must be present with any circuit in the form of the voltage drop across the filter choke. Also, the system has the improved bias regulation characteristic found in the circuit of Fig. 3.

The 6F5 tube shown in Fig. 4 is biased by the first method discussed in this article in connection with Fig. 2. This is a particularly satisfactory method for such low power, high-mu tubes requiring very low values of bias and having an extremely low plate current. The cathode resistor for a 6F5 in an ordinary cathode bias circuit is of the order of 4500 ohms, and thus, in addition to the other advantages of the circuit explained in connection with Fig. 2, the reduction of this value to 190 ohms eliminates the need of a bypass condenser—a comparatively expensive and bulky part.

**A TRUE FIXED-BIAS JOB**

So far we have not achieved our main goal—a bias voltage developed by a current which will be absolutely constant and independent of varying tube conditions. This aim may be reached in the circuit of Fig. 5. This unit makes a most satisfactory phono amplifier with an amazingly low distortion level and high output. The cathode of the 1-V bias rectifier is connected to one of the high voltage transformer leads. It is obvious that this connection of the rectifier

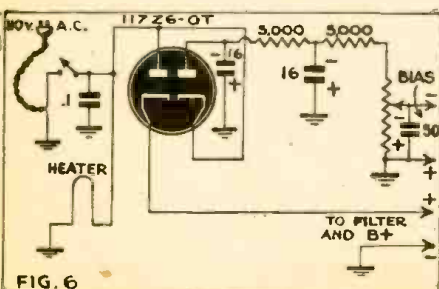

FIG. 6 One 117Z6-G used to supply both high and bias voltages for a small receiver or amplifier.

**HARRISON HAS IT!**

**FOR URGENT WAR WORK—**

**HALLICRAFTERS**

**RECEIVERS AND TRANSMITTERS**

**TUBES  
CONDENSERS  
RESISTORS  
TRANSFORMERS**

**AND THOUSANDS OF OTHER CRITICAL ELECTRONIC PARTS!**

**PURCHASING AGENTS—**

Call upon us for your high priority requirements of equipment and components for your production and development work.

We usually have it in stock!

**HARRISON**  
RADIO CORPORATION

11 WEST BROADWAY

Phone WOrth 2-6276

NEW YORK CITY 7

**FOR THE HOME FRONT—**

**CODE PRACTICE SET**

Buzzer and key, heavily nickel plated, of single unit construction, mounted on wood base. Adjustable high frequency pitch. Complete with silk covered cord. In attractive box with code chart on cover. Works on one or two flashlight or dry cells.

Postpaid—\$2.45

**6L6G** First grade, \$1.37 ea.  
meter tested, 3 for \$3.75  
**TUBES** fully guaranteed postpaid

**DYKANOL CAPACITORS**

Cornell-Dubilier oil filled, hermetically sealed metal cased condensers, 4 mfd. capacity. Rated at 220 Volts AC working, will stand over 600 Volts D.C. Ideal for amplifiers, receivers, power packs, etc. (Filtering action equivalent to 12 mfd. electrolytic but with better safety factor, longer life). \$2.25 (3 or more shipped postpaid).

**P. M. DYNAMIC SPEAKERS**

5 inch, with output transformer to match single plate of 8000 ohms \$1.95  
Magnavox, 10 inch, 16 ounce magnet! 6 ohm voice coil ..... \$5.25  
(Not Postpaid)

Immediate delivery of the above items, without priority, while quantities last. SEND REMITTANCE WITH ORDER, TODAY! (Money back if not satisfied.)



**"THE INDUCTANCE AUTHORITY"**

By EDWARD M. SHIEPE, B.S., M.E.E.

THE ONLY BOOK OF ITS KIND IN THE WORLD. "The Inductance Authority" entirely dispenses with any and all computation for the construction of solenoid coils for tuning with variable or fixed condensers of any capacity, covering from ultra frequencies to the borderline of audio frequencies. All one has to do is to read the charts. Accuracy to 1 per cent may be attained. It is the first time that any system dispensing with calculations and correction factors has been presented.

There are thirty-eight charts, of which thirty-six cover the numbers of turns and inductive results for the various wire sizes used in commercial practice (Nos. 14 to 32), as well as the different types of covering (single silk, cotton-double silk, double cotton and enamel) and diameters of 1/8, 3/8, 1, 1 1/8, 1 1/4, 1 1/2, 1 3/4, 2, 2 1/4, 2 1/2, 2 3/4 and 3 inches.

Each turns chart for a given wire has a separate curve for each of the thirteen form diameters.

The book contains all the necessary information to give the final word on coil construction to service men engaged in replacement work, home experimenters, short-wave enthusiasts, amateurs, engineers, teachers, students, etc.

There are ten pages of textual discussion by Mr. Shiepe, graduate of the Massachusetts Institute of Technology and of the Polytechnic Institute of Brooklyn, in which the considerations for accuracy in attaining inductive values are set forth.

The book has a flexible fiber cover, the page size is 9 x 12 inches and the legibility of all curves (black lines on white field) is excellent.

Order from your dealer or direct—\$2.50

**GOLD SHIELD PRODUCTS**

350 Greenwich St., (Dept. R.C.9), New York City

Now you can own these "Western Union" Standard Electric **RADIO-TELEGRAPH SIGNAL SETS**

**MONEY BACK GUARANTEE**

Be Your Own TELEGRAPH OPERATOR

YOU GET 2 SETS LIKE THIS

IT BUZZES, as used in wireless IT FLASHES, as used in telegraphic IT CLICKS, as used in night signaling! You get TWO receiving and sending outfits, each in a compact metal case containing Sending Key, Buzzer, Flasher Bulb, Clicker and battery compartment, completely wired for sending and receiving. You also get complete instructions and Operator's Manual including "Morse Code", "Q Signal Code", and "Aids in learning international code". Use sets for home learning and to send messages between rooms or buildings.

2 SETS with OPERATOR'S MANUAL for Only **\$3.95** POST PAID

**RADIO WAREHOUSE MARKET** 364 Wooster Ave., Akron, Ohio. Tear out this ad, write name and address in mar. En. mail \$3.95 and we will send outfits at once POST PAID. Or order C.O.D. pay Postman for outfits plus postage.

**OPPORTUNITY AD-LETS**

Advertisements in this section cost 20 cents a word for each insertion. Name, address and initials must be included at the above rate. Cash should accompany all classified advertisements unless placed by an accredited advertising agency. No advertisement for less than ten words accepted. Ten percent discount six issues, twenty percent for twelve issues. Objectionable or misleading advertisements not accepted. Advertisements for October, 1943, issue must reach us not later than September 9, 1943.

Radio-Craft • 25 W. B'way • New York 7, N. Y.

**RADIO SERVICEMEN AND EXPERIMENTERS SEND** for our giant radio catalogue. Save dollars. United Radio Co., (1000P) Newark, N. J.

**USED CORRESPONDENCE COURSES AND TECHNICAL** Books Bought, Sold, Rented, Catalog Free. Educational Exchange, Henagar, Alabama.

**I'LL SHOW YOU HOW TO GO PLACES IN RADIO MILITARY OR CIVILIAN**

**TRAIN IN SPARE TIME AT HOME . . . . or AT CAMP**

The greatest OPPORTUNITY that ever existed in Radio is open to you RIGHT NOW! Don't miss it! My practical Home Training will fit you quickly for a profitable Radio Repair business of your own . . . OR for a good-paying job in one of the Nation's Radio plants at work on equipment for planes, tanks, ships, etc. . . . OR for higher rating and better pay if you enter the Army, Navy or Marines.

**NO PREVIOUS EXPERIENCE NEEDED**

Sprayberry Training starts right at the beginning of Radio. You can't get lost. My tested and proved methods will get each subject across to you in simple, understandable style. Your success is my full responsibility. You learn Aviation Radio, Radio Set Repair and Installation Work, Mobile Radio (Auto-Tank), Television, Frequency Modulation, Signal Tracing, etc. You will be prepared to cash in on the coming great era of Electronics and Electronic equipment.



**READ WHAT GRADUATE SAYS "Salary Has Increased"**

"Since I have finished your Radio training I had to enlarge my laboratory with additional equipment, as I have all the Radio repair work that I can handle. My salary has increased to 50 to 75 dollars a week. I install transmitter equipment and public addressing systems. Money can not buy the training that I received through your Academy." Asa Smith, Post Box 528, Ft. Leavenworth, Kansas.

**EARN WHILE YOU LEARN**

Along with your Training, you will receive my famous Business Builders which can bring you in a nice profit shortly after you begin my Course. No matter if you remain a civilian or enter military service, my Radio Training will give you the background and knowledge to cash in on the marvelous future that lies ahead.

**EASY TO START . . .**

Remember it is not necessary for a Sprayberry student to have any previous experience in the field of Radio. You can master the Course in your spare time. It will not interfere in any way with your present duties.

**GET THE FACTS ABOUT MY TRAINING—NOW! TAKE THE FIRST IMPORTANT STEP TOWARD THE MONEY-MAKING FUTURE OF YOUR DREAMS. ALL FEATURES ARE FULLY EXPLAINED IN MY BIG, ILLUSTRATED FREE BOOK. WRITE FOR IT AT ONCE.**



**RUSH THIS COUPON FREE for BIG FREE BOOK**

**DON'T DELAY! ACT NOW!**

**SPRAYBERRY ACADEMY OF RADIO**  
 F. L. SPRAYBERRY, Pres.  
 620-J University Place, N. W., Washington, 9, D. C.

Please send me FREE copy of "HOW TO MAKE MONEY IN RADIO."

Name..... AGE.....

Address.....

City..... State.....

Tear off this coupon, mail in envelope or paste on penny postcard.

will cause a negative voltage approximately equal to the R.M.S. transformer rating for 1/2 the high voltage secondary to appear across C1.

We are now faced with the problem of dropping the voltage to the required values for biasing the tubes and of filtering said voltage particularly thoroughly, since we are using 1/2-wave rectification. These two purposes are accomplished at the same time by the two resistors R1 and R2, which act as dropping resistors and also as filter resistors in conjunction with C1, C2, and C3. Owing to the high values of R1 and R2, filtering is very efficient, thus reducing hum to a minimum. C4 further filters the bias to insure hum-free operation of the more sensitive first audio stage. R3 and R4 are I.R.C. potentiometers with metal backs by the aid of which they were soldered to the under-side of the chassis. Their shafts were cut off fairly short and slotted to provide screw-driver adjustment. The bias voltages should be measured at the center terminals of the potentiometers themselves with an accurate and sensitive voltmeter, and no attempt should be made to measure the bias at the grids of the tubes unless it is done with an electronic voltmeter. The potentiometers provide exceedingly fine adjustment of the optimum bias voltages (-8 volts for the 6C5 and -20 volts for the 6F6).

This method of biasing is particularly applicable to A.C.-D.C. systems, where one rectifier can be made to serve for both power and bias supplies. Fig. 6 is a good example. Other tubes such as the 25Z5, 25Z6, 50Z7G, and 50Y6GT may be similarly connected, the only difference being in the filament ratings. Thus the designer can choose a rectifier which will have filament requirements such that it may be used in conjunction with the other tubes he intends to use.

**A GOOD AMPLIFIER**

Finally, I give the circuit (Fig. 7) and general view (photograph) of another amplifier operating on the same principle as the unit of Figs. 5 and 6 but of greater power output. The 6L6G in the output stage will deliver full 10 watts at a minimum of distortion. The power transformer delivers 375 volts R.M.S. each side of the center-tap, at 150 ma. For this reason the author thought it necessary to use a separate, ungrounded winding for the 1-V heater to insure against breakdown between cathode and heater. This is probably not necessary, but it is best to be on the safe side. Moreover, a small resistance was inserted as shown between the 1-V plate and the first filter condenser, since the light load placed on the 1-V by the bias voltage divider will otherwise cause an excessive voltage to

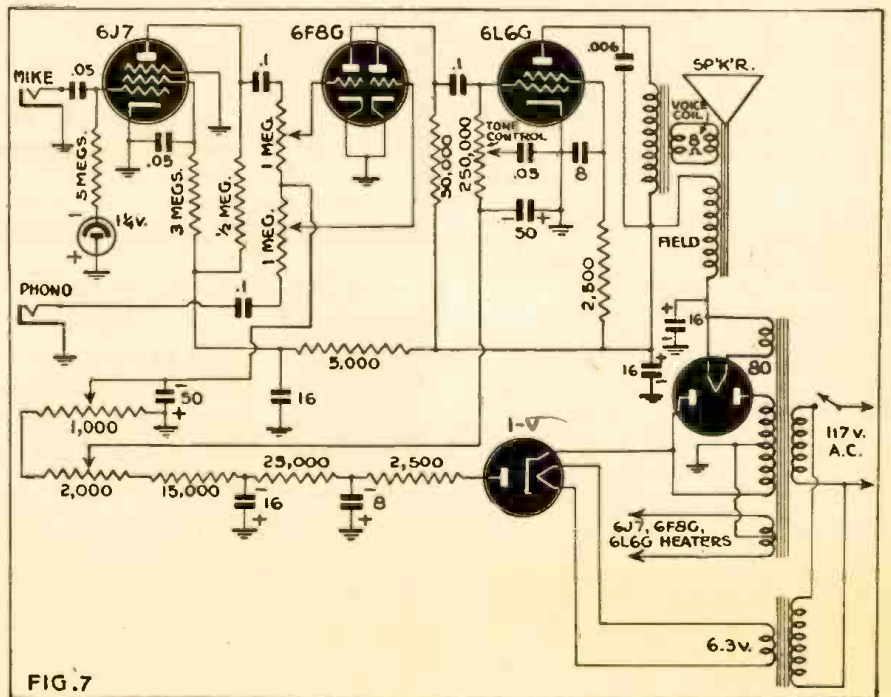

**FIG. 7**

The final circuit, combining all the advantages and eliminating the drawbacks of those previously discussed. Genuine fixed bias, stability and freedom from intercoupling work together to give this amplifier 10 watts of distortion-free output.

In hooking up the amplifier, one should be sure to ground the positive leads of C1, C2, C3, and C4, since the voltage being filtered is negative with respect to ground. The values of R1 and R2 may be allowed to vary over quite a range. In general, the current drawn by the bias system should be kept pretty low—around 10 ma. or less—to avoid unnecessary current drain and unbalancing of the power transformer's high-voltage secondary by drawing appreciably more current off one half than off the other. The values given in Fig. 6 were found to be quite satisfactory with this circuit. The potentiometers should be such that the desired bias voltages can be obtained by setting the arm of each pot near the center of its range. The values given for R3 and R4 in the diagram should work perfectly well.

build up across said condenser; as it is, a 500-volt rating is desirable for that part. In other ways, the bias supply is similar to the one of Fig. 5. The rest of the amplifier follows standard practice.

It should give long and trouble-free service at an efficiency, output level, and distortion level seldom equalled in single tube class A1 output stages using the available receiving-type tubes.

In closing, let me urge again the importance of well-regulated bias for maximum efficiency, power output and minimum distortion.

I trust that one or more of the ideas of circuits suggested in this article will be of some help to those ambitious amateurs who want to get as much out of their tubes as the commercials do. Try it once and be convinced!

**PICK-UP PERFORMANCE**

(Continued from page 732)

Still another problem presents itself since the adjacent grooves are also modulated and the relative wall thicknesses between adjacent grooves vary more or less as differences of the modulation frequencies in these grooves. As a result, the varying groove wall elastance will super-impose a "ghost" modulation upon the modulation cut in the groove retaining the stylus tip. This "ghost" frequency signal effect will result in some intermodulation and "masking" interference effects.

**SKATING OR BOB-SLEDDING**

Another type of tracking error encountered in phono playback work is known as "skating". This effect is especially troublesome when the stylus tip is too small for the modulation groove trough. When undersized, it will careen about the modulation grooves like an Olympics bob-sled making the Lake Placid run. Skating will be further exaggerated if the stylus tip pressure is too light for the stylus mechanism's impedance.

Obviously, if the center of the stylus tip does not follow the center-line of the modulation troughs at all times, the wave form of the signal put out by the pick-up will not be an accurate duplication of the modulation waves cut into the record disc. Since the wave-form distortion is not symmetrical, the distortion is even order harmonic and cross-modulation distortion for the most part.

Even where an exact stylus-in-groove fit occurs, even-order harmonic distortion is still possible theoretically. A simple geometric construction of two parallel sine-waves representing the modulation groove walls and a series of included tangent circles representing the motion of the stylus spherical tip through the modulation trough will show up this theoretical fact. A curve line drawn through the locus of circle centers will not be a true sine-wave curve by reason of the trigonometry involved.

This theoretical distortion effect will be aggravated when the modulation frequencies are complex or vary in frequency abruptly. However, this same effect should more or less take place during the recording operation and a complementary compensating effect should take place between the cutting and play-back operations. At any rate, this is an interesting point to speculate over.

**THE NEEDLE AND THE GROOVE**

If the stylus tip is wider than the recording groove (pinch effect), less skating will result but a high frequency cut-off may take place and damage of the high-frequency modulation waves may also take place since the stylus tip diameter is then comparable to these modulation wave widths.

Theoretically, the compromise which produces the best all-round tracking is a slight "pinch" effect where the stylus is slightly wider in diameter at the tip than the groove width. Beers and Sinnet of RCA recommend a compromise set of specs as shown on the diagram, Fig. 2.

While such specs present an optimum compromise, it is hard to see how they can be maintained in practise since a stylus is eventually worn down to fit the recording grooves by the protective abrasives incorporated within the recordings' plastic materials. This is especially true of steel and alloy needles. Even a jewel stylus will in time be worn down to some average sized and shaped tip which will be determined by the types and makes of recordings with which it is used. Here again, the importance of constant stylus renewal is brought out.

Another minor distortion effect along these same lines is the fact that the modula-

**HALLICRAFTERS ★ HALLICRAFTERS ★**

**LET'S ALL PITCH IN!**

WE CAN all help win this war by selling our government the communications receivers and equipment they need quickly and in sufficient quantities.

That is the reason I pay highest cash prices for used communications equipment.

When this war is over you will be in the market for new equipment and by taking advantage of my offer to purchase your present equipment at highest cash prices you will be in a position to buy new and better equipment than you now own.

Write, telephone or telegraph me description of your used communications receivers, transmitters and parts of standard make; you will be paid cash immediately without bother or red tape. I am particularly interested in *Hallcrafters*.

I also have a store at 2335 Westwood Blvd., West Los Angeles, Calif.

**Bob Henry, W9ARA**  
**HENRY RADIO SHOP**  
BUTLER, MISSOURI

**COMPLETE STOCKS**

I still have large stocks of receivers, 2½ meter equipment, meters, tubes, transformers, resistors, condensers, panels, chassis, and radio parts of all sorts. I sell and rent code teaching equipment. Your orders and inquiries invited.

"WORLD'S LARGEST DISTRIBUTOR OF COMMUNICATIONS RECEIVERS"

HALLICRAFTERS ★ HALLICRAFTERS

**Complete Plans**

For Building Useful and Practical Things at Home. Each issue of Popular Homecraft is crammed with plans for making such beautiful and useful things as: Furniture, Bird Houses, Lamps, Outdoor Garden Furniture, Candle Equipment, etc. Covers in the work, tools, wood-working, leathercraft, C O P P E R. You'll find "how" to make almost everything from the pages of Popular Homecraft. Scores of drawings and photographs make every step simple as A B C. A real "How-To-Do-It" magazine.



Six-Months' Trial \$1.00

Send \$1.00 today for trial six months' subscription. Money Back if Not Delighted.

**POPULAR HOMECRAFT**

937 Palmolive Building Chicago, Ill.

**Trial 6 Months \$1.00**

**PATENTS—TRADE MARKS**

Booklet concerning Inventions & Patents Form "Evidence of Conception" with instructions for use and "Schedule of Government and Attorneys Fees"—Free

**LANCASTER, ALLWINE & ROMMEL**  
Registered Patent Attorneys  
436 Bowen Bldg. Washington, D. C.

**Inventions Wanted**  
Patented or Unpatented

We have been successfully selling inventions, patented and unpatented, since 1924. Write us, if you have a practical, useful idea for sale.

**CHARTERED INSTITUTE OF AMERICAN INVENTORS**  
Dept. 100, 631 Pa. Ave., N.W., Washington, D.C.

**RADIO AND ELECTRONIC DEVICES**



**BURSTEIN-APPLEBEE CO.**

1012-14 McGee St. Kansas City, Mo.

**LEARN CODE** the way you'll be using it by **SOUND**



The best way to learn to read code is by listening to code. The best way to learn to send code is by hearing your own sending repeated back to you. With the new All-Electric Master Teleplex Code Teaching Machine, you learn code the natural, easy, fascinating way. Only instrument ever produced which records your sending in visible dots and dashes—then SENDS BACK your own key work at any speed you desire. There are NO PERFORATIONS—NO INK. Far superior to anything ever developed. . . . a marvel of simplicity. That's why practically every school teaching code uses TELEPLEX. We furnish complete course, including the All-Electric Master Teleplex. Give your personal instruction with a MONEY BACK GUARANTEE—all at a surprisingly low cost. Write today for FREE catalog 80. No obligations.

**TELEPLEX CO.,** 107 HUDSON ST. JERSEY CITY, N. J.

**RADIO PARTS**

WRITE FOR LIST  
MANY NEW VICTORY LINE PARTS

**John A. Cox**  
WHOLESALE RADIO PARTS  
PARKERSBURG, W. VA.

**COMPLETE  
CENTRALIZED  
SERVICE**  
on *Everything* in  
**RADIO AND  
ELECTRONICS**

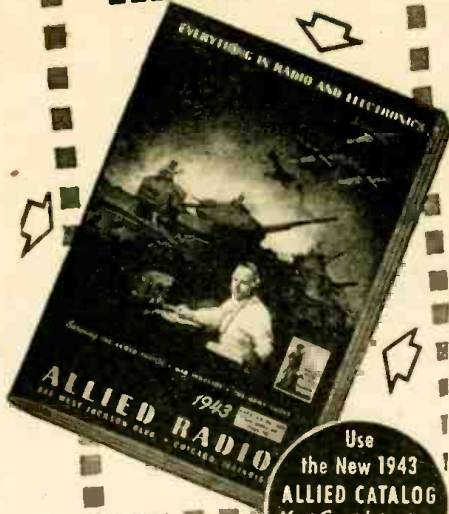

Use  
the New 1943  
**ALLIED CATALOG**  
Most Complete up-to-  
date Buying Guide  
**Free!**

**Allied SPEEDS SUPPLIES**  
for the Armed Forces... War Industries... Home Front

ONE quick, dependable central source of supply for all your Radio and Electronic needs . . . over 10,000 items for the Armed Forces, Radio Training, Research Laboratories, War Industries, and Service Replacement. Our large complete stocks speed delivery. Our experienced staff is ready to help you.

**6 Radio Books for 75c**

- Dictionary of Radio Terms. No. 37-751 **10c**
- Radio Data Handbook. No. 37-754 **25c**
- Radio Circuit Handbook. No. 37-753 **10c**
- Radio Builders Handbook. No. 37-750 **10c**
- Radio Formulas & Data Book. No. 37-752 **10c**
- Simplified Radio Servicing. No. 37-755 **10c**

Write for Quantity Prices

ALLIED RADIO CORP., Dept. 2-J-3  
833 W. Jackson Blvd., Chicago, Ill.

Please send following books (.....c enclosed)  
 FREE  37-750  37-752  37-754  
1943 Catalog  37-751  37-753  37-755  
 Send All Six Books

Name.....  
Address.....  
City..... State.....

**ALLIED RADIO**

tion waves are cut by a more or less semi-spherical sharp-edged stylus while the playback stylus has a smooth spherical-shaped tip. Obviously, the movement of two differently shaped needles through the same modulation grooves cannot be the same. This is especially true of vertically-cut "hill-and-dale" recordings used to some extent in radio transcription work.

The hill-and-dale modulation waves have been cut by a razor-edged cutting tool whose cutting edge is at all times practically tangent to these waves. However, the spherical tip of the playback stylus will be tangent to these hill-and-dale waves only at the hill-and-dale spots, or to put it in another way, only at the maximum amplitude swing spots of the modulation troughs. The back side of the spherical tip rides the oncoming hills and the front side of the stylus tip slides down the receding hill sides. It is obvious that if the center of the stylus tip does not remain in contact with the hill-and-dale modulation waves, its motion will not be a duplication of the modulation waves and the signal put out by the stylus mechanism will not be an accurate duplication of the recording modulations. The wave-form distortion is plainly non-symmetrical, and even-order harmonic distortion (mostly 2nd harmonic) and even-order harmonic cross-modulation distortion is the result. A similar distortion effect takes place to a much lesser degree in standard laterally-cut recordings.

**CURVED-TRACK EFFECTS**

Still another tracking error effect which must be considered is the theoretical groove-curvature distortion effect. Since the sound track is a circular spiral and not a straight groove, the modulation waves are not strictly true sine waves. They are warped since their axis is bent into a large circle.

This effect is more pronounced towards the inner grooves since the curvature of the inner grooves is greater.

The outer walls of the modulation grooves have a greater diameter and a longer perimeter than the inner groove walls. The two half-cycle peaks of the modulation waves are not the same in the case of a simple sine-wave signal and we also have an unbalance distortion effect to contend with.

Two final minor tracking error effects exist:

If an older type heavy-pressure pick-up is used for play-back work and a mark is inscribed on both the t.t. rim and record disc edge before the recording is played, the marking on the record disc will be found to be displaced 1/4 to 1/2 inch in the direction

opposite to the t.t. rotation after the recording has been played off. In other words, radial record disc slip exists. This is due to the stylus friction drag and vibration effects.

While such slip is small as compared against the total sound track length, it can be assumed that this slip takes place intermittently in small amounts during transient high-amplitude passages which usually occur at the lower frequencies. This record disc slip amounts to a variation in t.t. drive motor R.P.M. and the net result is a trace of the familiar "wow".

Another minor effect similar to this and noted at about the same time, is a back-lash effect between the record disc center hole and the t.t. center-pin. Again, this lateral chatter effect is more evident at lower frequencies and where heavier pressure pick-ups are employed.

If, in a high-fidelity phono system, a pin or shim is jammed in between the record disc hole and the t.t. center pin, a slight improvement in low-frequency response can be detected by the unaided ear.

Evidently, the record disc slips or oscillates in a horizontal plane at low audio frequencies, due to weight and momentum of the relatively heavy pick-up mechanism. This may result in a small amount of low-frequency cut-off and distortion.

While these two effects will not be so noticeable where low-pressure super-fidelity pick-ups are concerned, it might be worthwhile to employ some sort of a center-pin lock-nut or jam-sleeve to anchor down record discs used in hi-fidelity radio transcription work.

It is highly possible that sound technicians checking t.t. motor R.P.M. variation wow and gear tooth torque variation wow may have had their readings, charts, curves and general findings modified by these two record disc slip effects without their knowledge.

**PICK-UP DESIGN FACTORS**

There are still other factors which must be taken into account in the design of pick-up mechanisms. These include flexing of the stylus shaft and its effect upon the higher audio frequency response; the impedance (mechanical) of the stylus mechanism; the resonance frequency of the pick-up arm; the relationship between the stylus pressure, stylus mechanism impedance, record groove material elastance and stylus and groove shape in order to dampen out resonance effects and flatten and extend frequency response and prevent too much skating.

**POPULAR ELECTRONICS**

(Continued from page 713)

may be used for the case. The hole for the window should be cut slightly smaller than the surface of the cell, and the glass window should be set in place with cement of the type used for model airplanes. The cell itself should be carefully kept free of dust and dirt. Electrical connections are established with the pig-tails extending from the cell. These are connected (and soldered) to the binding posts on the container.

A wide-mouthed bottle may be employed, the mouth being cemented to a baseboard with the model-airplane cement previously mentioned. This simple mounting provides a dust-proof and practical protection for the cell. Of course, the cell is affected by light from all angles, with such an arrangement, and there are many applications where this exposure might not be desirable.

Relays for such cells may be of either the polarized or the unpolarized type. They may be either purchased or home-made, and they do not need to be of the ultra-

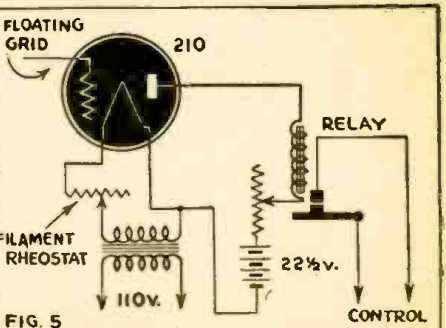

FIG. 5

The Type 210 photo-cell. Other old triodes, such as the 45 and 200-A, are photo-sensitive.



**SQUARE-WAVE GENERATOR**

(Continued from page 715)

three dollars. (A mounted cell, complete with relay, is shown in the photo.) Fig. 2 illustrates the connections necessary for a relay where some mechanism requiring heavy current such as a bell or a lamp is to be operated photoelectrically.

The cell, when complete, may be utilized in a variety of ways. Fig. 3 shows some industrial applications which may suggest ideas to the amateur experimenter. Top, we have a butter-checker. One-pound packages of butter pass down the conveyor past the light source and photo-cell. Each pound pack must interrupt the light for a certain space of time. If the pound is short, the interruption is not long enough, and the belt at right angles to the conveyor is set in motion, throwing the defective pack off the conveyor.

Bottom is a device used in certain textile mills, where the loop of cloth going to certain processes must be kept a certain length. In this case, if the loop becomes long enough to interrupt the lower light beam, the rollers supplying the cloth are slowed, if so short that the upper beam is cleared, the roller taking it away is slowed. Thus the length of the loop is maintained between these two limits.

The 22½ volt battery may be the type used in radio. An improvement is shown in Fig. 4 where a bucking battery of 1½-volts and a 5,000-ohm radio potentiometer are used to make the circuit more responsive. This arrangement improves the operation of the cell by canceling the so-called "dark current" or the current that normally flows through the cell when a battery is connected to it.

Experiments conducted with the aid of the photoelectric cell may be many and varied. Using the various circuits shown, the builder may entertain himself for hours just learning new things about the marvelous properties of these devices.

Thanks to the intensive research of Mr. W. P. Kickle, of Owensboro, Kentucky, a surprising photoelectric effect was discovered in ordinary radio vacuum tubes. To electrical experimenters this will be good news, because it means that photoelectric cells can be devised from inexpensive radio tubes.

It has been found that the old type 210, the 245 and the 250 tubes are photoelectric to a marked degree, and that the light response is sufficient to trip a cheap relay. Such tubes may still be found in old sets taken in by radio dealers.

Tubes which give the best results are those having open or clear tops so that light from external sources can reach the grid. It is essential also that the grid prong be cut off as illustrated.

A circuit is given in Fig. 5. The filament voltage is regulated by a power rheostat in the secondary of the transformer circuit. The experimenter will have to discover the best filament voltage by test.

The relays used in connection with these new photoelectric cells should be capable of operating on a range between 1 to 10 milliamperes.

When operating the tube, it must be remembered that the more light that reaches the grid of the tube, the greater will be the current output. Therefore it is advisable that the tube be installed in such a position that the beam strikes the top head-on, as illustrated in an accompanying photo at the top of Page 713, which shows a small motor being controlled with a flashlight and a 210 tube.

The vacuum tubes will be found unduly sensitive to body capacity, so it will be necessary to cover the tube with a metal shield (as illustrated in the photo on Page 712), which is grounded to the negative filament. The top of the shield is left open.

rated at an absolute accuracy of plus or minus 2% were used in this instrument.

The output attenuator is of the pure resistive type. It is hooked up in the output of a cathode follower type of circuit. The first step (lowest volume) is variable, and is a 50-ohm resistor. The succeeding steps in ohms are: 100, 200, 500, 1,000, 1,500 and 2,000 ohms, this latter being the total cathode resistance.

No means for generating pulses has been incorporated in this instrument, since it was felt that the sacrifice of accuracy involved in including this feature would be out of place in a piece of laboratory apparatus. It is possible to bring about a frequency change of almost 25% of the calibrated dial readings when operating the device as a pulse generator. To correct this would necessitate additional compensating features which would only complicate the use of the instrument.

For those who wish to incorporate pulse width control, variable over the entire range with a ratio of 4 to 1, the following changes will give the desired results:

A control of 1 megohm is inserted in series with the plate supply to tube No. 1. The screen of the second tube is bled to

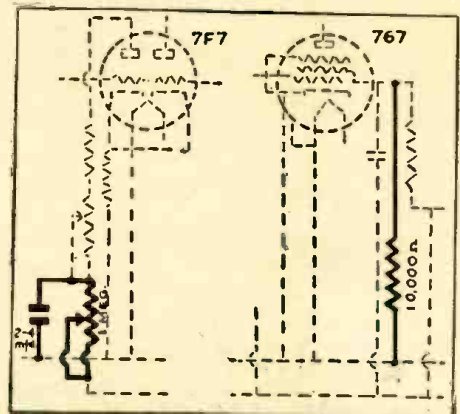

Changes necessary to adapt the square-wave generator for the production of pulses are shown in heavy lines on the figure above.

ground through a 10,000-ohm, 2-watt resistor and is also bypassed by a 10-mfd. 450 volt electrolytic condenser.

Varying the 1-megohm control will then produce pulses as desired, of any ratio up to the 4 to 1 maximum.

**THYRATRON RECTIFIERS**

(Continued from page 717)

G. E. THYRATRONS

**TECHNICAL INFORMATION**

These data are for reference only. For design information see the specification.

GENERAL DESIGN	PG-95	PG-97	PG-98-A	PG-154
Number of Electrodes	4	4	4	4
Cathode Type	Indirectly Heated	Coated Fil.	Coated Fil.	Coated Fil.
Voltage, volts	•5.5	5.0	2.5	2.5
Current, amperes approx	•5.0	4.5	5.0	5.0
Heating Time, typical sec		300	5	5
Tube Voltage Drop, volts				
Maximum	26	26	26	30
Minimum	10	10	8	10
Approx Starting Characteristic				
Anode Voltage	100 1000	100 1000	60 500	60 100
Shield-grid Voltage	0 0	0 0	0 0	0 0
Control-grid Voltage	+3.5 -9.0	+1.0 -10.0	0 -10.0	0 -3.5
Average Anode to Control Grid Capacitance, µmf	0.2	0.3	0.5	0.3
Ionization Time, microsec approx	1000	1000	1000	1000
Ionization Time, microsec approx	10	10	10	10
Net Weight, ounces approx	5	5	5	5
Shipping Weight, pounds approx	7	4	4	7
Installation and Operation, Pub. No.	GEH-994	GEH-994	GEH-994	GEH-994
<b>MAXIMUM RATINGS</b>				
Max Peak Anode Voltage, volts				
Inverse	1000	1000	500	500
Forward	1000	1000	500	500
Max Neg Control-grid Voltage, volts				
Before Conduction	1000	1000	70	300
During Conduction	10	10	10	10
Max Neg Shield-grid Voltage, volts				
Before Conduction	300	300	50	50
During Conduction	5	5	5	5
Max Anode Current, amperes				
Instantaneous, 25 cy and above	•40	15	2.0	2.0
Instantaneous, below 25 cycles		5.0	1.0	1.0
Average	•0.5	2.5	0.5	0.5
Surge, for design only		90	20	20
Max Control-grid Current, amperes				
Instantaneous	1.0	0.25	0.25	1.0
Average	0.25	0.05	0.05	0.25
Max Shield-grid Current, amperes				
Instantaneous	1.0	0.25	0.25	1.0
Average	0.25	0.05	0.05	0.25
Max Time of Averaging Current, sec	15	15	15	15
Temperature Limits, cond mercury C ambient C	40-80	40-80		
			-20 - +50	-20 - +50

\*These ratings apply only when the PG-95 is used for ignitor firing.

(Continued on following page)

# POPULAR ELECTRONICS

**HIGH EFFICIENCY** results in **Sound National Defense** that is why **NATIONAL DEFENSE SOUND SYSTEMS** are equipped with **University Reflex** **HIGH POWER LOUDSPEAKERS** **UNIVERSITY LABS.** 225 VARICK ST. N. Y. C.



**USED Correspondence Courses** COMPLETE HOME-STUDY COURSES and self-instruction books, slightly used. Sold, rented, exchanged. All subjects. Satisfaction guaranteed. Cash paid for used courses. Full details and 84-page illustrated bargain catalog FREE. Write today! **NELSON COMPANY, 321 S. Wabash, Dept. 210, Chicago**

**The Book that takes Drudgery out of Mathematics** Only **50c** postpaid. Entire Chapter on Special Mathematics for the Radio Technician.

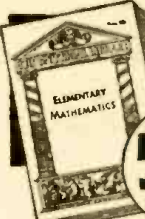

## ELEMENTARY MATHEMATICS

● EASY — SIMPLIFIED — PRACTICAL ●

Here is the book that gives you a good background in mathematics; that takes all the irritation and drudgery out of it. You don't need to be scared of mathematics, because here's the subject explained without frills, without useless computations.

### CONTENTS OF BOOK

- CHAPTER I. Arithmetic—Addition—Subtraction—Multiplication—Division.
- CHAPTER II. Factoring and Cancellation—Fractions—Decimals—Percentage—Ratio and Proportion.
- CHAPTER III. The Metric System.
- CHAPTER IV. How to Measure Surfaces and Capacity (Geometry).
- CHAPTER V. Powers and Involution—Roots and Evolution.
- CHAPTER VI. Mathematics for the Manual and Technical Craftsman—Thermometer Conversions—Graphs or Curve Plotting—Logarithms—Use of the Slide Rule.
- CHAPTER VII. Special Mathematics for the Radio Technician.
- CHAPTER VIII. Commercial Calculations—Interest—Discounts—Short Cut Arithmetic.
- CHAPTER IX. Weights and Measures—Useful Tables.

ONLY **50c** POSTPAID

Send today for your copy of this indispensable book. It can be carried readily in your pocket. (Size 6 x 9 in.)

Send Stamps, Cash or Money Order to

## TECHNIFAX

1917 S. STATE ST., RC-943, Chicago, Ill.

TECHNIFAX 1917 S. State St., Chicago, Ill.

Enclosed herewith 50 cents, for which mail to address below your ELEMENTARY MATHEMATICS.

NAME .....

ADDRESS .....

CITY ..... STATE ..... RC-943

## VIBRATOR SUPPLY

For **FARM RADIOS**

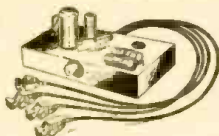

**MODEL "Y."** Adapts any standard 1½-volt Farm Radio for 6-volt Storage Battery operation. Low drain. No radio changes. Guaranteed. Weight, 4 lbs. Complete (wholesale)—\$6.95.  
**MODEL "Z."** Adapts 4, 5 or 6 tube, 2-volt radios for 6-volt operation. Complete (wholesale)—\$7.95.  
**BARGAIN BULLETIN**—on radio and electrical parts. Prompt shipment. Large stock. Sent on request. Write today.

**McGEE RADIO & ELECTRIC CO.**

R-1225 McGee Street Kansas City, Mo.

## WESTINGHOUSE THYRATRONS

TECHNICAL INFORMATION										
TUBE TYPE	KU-627	KU-628	WL-631	WL-632	KU-634	KU-676	WL-677	Units		
No. of Electrodes	3	3	3	4	3	3	3			
Cathode Information	Coated Pila.		Indirect Heater	Indirect Heater	Coated Pila.	Indirect Heater	Indirect Heater			
Type	Coated Pila.		5.0	5.0	5.0	5.0	5.0			
Voltage	2.5	5.0	5.0	5.0	5.0	5.0	5.0	Volts		
Current	6.0	11.5	4.5	4.5	11.5	9.5	9.5	Amperes		
Min. Heating Time	10	40	300	300	40	300	300	Seconds		
Tube Voltage Drop (Grid tied to cathode)			24	26	24	24	24	Volts		
Maximum	8	8	10	10	8	8	8	Volts		
Minimum	8	8	10	10	8	8	8	Volts		
Average	15	15	15	15	15	15	15	Volts		
Approximate control characteristics at 40° Cent. condensed mercury temperature. See curves.										
	Ep:	Eg:	Ep:	Eg:	Ep:	Eg:	Ep:	Eg:	Ep:	
Ep - Peak Forward Volts on anode	40	0	30	0	60	0	30	0	100	
	0	250	-4	100	-1.6	*100	+3.5	250	-4	
	300	-2	2500	-15	Volts					
Eg - DC Volts on grid	800	-6	1000	-8	600	-6.0	*500	-6.0	1000	
	700	-4	5000	-28	Volts					
	1500	-9	2100	-14	1000	-8.0	*1000	-9.0	2100	
	1000	-6	7500	-42	Volts					
Average Grid Current (just before breakdown)	4	5	5	-	5	5	-	Microamps		
De-ionization time (max. approx.)	1000	1000	1000	1000	1000	1000	1000	Microsecs		
Ionization Time (approx.)	10	10	10	10	10	10	10	Microsecs		
Anode-Grid Capacitance (approx.)	2.5	4	4.3	0.2	4	5	5	uuf.		
Socket Style	766732	793202	Std. UX	Std. UX	793202	793202	793202			
Top Connector Style	829334	829334	829334	829334	829334	829334	829334			
Dimensions of Tube (Overall)			7-1/4	7-15/16	9	12	13	Inches		
Maximum Length	7	9-1/4	6-3/4	7-7/16	8-1/2	11-1/2	11-1/2	Inches		
Minimum Length	6-1/2	8-3/4	3	7-7/16	7-13/16	3-7/8	3-7/8	Inches		
Maximum diameter	2-7/16	3-1/4		3-3/4				Inches		
Max. Control Anode Potential	2,500	2,500	1000	1000	7,500	1,000	7500	Volts		
Inverse	1,250	1,250	1000	1000	7,500	1,000	7500	Volts		
Peak Grid Voltage Range			500	500	500	500	500	Volts		
Max. Negative Value	500	500	500	500	500	500	500	Volts		
Max. Positive Peak	12	12	12	10	12	12	12	Volts		
Shield Grid Voltage Range			-	-	300	-	-	Volts		
Max. Negative Value	-	-	-	-	5	-	-	Volts		
Max. Positive Value	-	-	-	-	-	-	-	Volts		
Max. Anode Current Values			Instantaneous, 25 cycles and above	2.5	8.0	15	15	5.0	40	**15
Instantaneous, below 25 cycles	-	-	-	-	5	-	-	-	-	Amperes
Average	0.64	2.0	2.5	2.5	1.25	6.4	**4.0	Amperes		
Surge (design only)	25	80	90	90	50	200	**16	Amperes		
Max. Control Grid Current			Instantaneous	.25	.80	1.0	1.0	.50	1.0	Amperes
Average	.06	.20	.25	.25	.12	.25	.25	Amperes		
Max. Shield Grid Currents			Instantaneous	-	-	-	-	-	-	Amperes
Average	-	-	-	0.25	-	-	-	Amperes		
Max. Time of Averaging Anode, Grid and Screen Grid Current	70	30	15	15	30	30	30	Seconds		
Condensed Mercury Temperature Value			Maximum	70	70	80	80	50	70	° Cent.
Minimum	25	25	40	40	25	25	25	° Cent.		
Optimum Range	40-45	40-45	40-45	40-45	40-45	40-45	40-45	° Cent.		

\* With shield grid at 0 volts.

\*\* These ratings apply only when the tube is used in circuits which limit the short circuit current to the indicated value. Approval for any applications must be obtained from the tube manufacturer.

## THE LISTENING POST

(Continued from page 738)

Mc.	Call	Location and Schedule	Mc.	Call	Location and Schedule
10.22	PSH	RIO DE JANEIRO, BRAZIL. 8:15 to 8:30 pm.	11.37	—	CROATIAN FREEDOM STATION. 2:30 to 2:40 pm.
10.250	XGAP	PEIPING, CHINA. 10 am to noon.	11.470	—	AZAD MOSLEM RADIO; 9:30 to 9:45 am.
10.380	—	"STATION DEBUNK": Station of all free. 8:30 to 9:30 pm; says he is in the U.S.A.	11.470	—	"NATIONAL CONGRESS RADIO" (INDIA); 12:15 to 12:53 pm.
10.445	—	MOSCOW, USSR. 7:40 to 8:20 am.	11.470	—	"VOICE OF FREE INDIA"; 10 am to 12:05 pm.
10.543	DZD	BERLIN, GERMANY.	11.6	—	RUMANIAN FREEDOM STATION. 1:45 to 1:55 pm, 4:15 to 4:25 pm.
10.610	ZIK2	BELIZE, BRITISH HONDURAS. 9 to 9:15 pm.	11.623	COK	HAVANA, CUBA; daily, 1 pm to 1 am; Sundays, 2 to 8 pm.
10.620	CEC	SANTIAGO, CHILE. 7:30 to 8:15 pm; irregular.	11.675	OPL	LEOPOLDVILLE, BELGIAN CONGO. 3:15 to 3:30 pm; 4:30 to 4:45 pm.
10.620	KES3	PACIFIC COAST; 1 to 6 am	11.68	GRG	LONDON, ENGLAND. 5:15 to 7:15 pm.
10.840	KWV	PACIFIC COAST; 2 to 4:30 am.	11.70	H85A	PANAMA CITY PANAMA.
11.145	WRUS	7:30 pm to 2 am	11.705	CBFY	VERCHERES, CANADA. 7:30 am to 11:30 pm.
11.145	WCDA	NEW YORK CITY; 5 to 6:45 pm.	11.705	SBP	MOTALA, SWEDEN. 12 to 2:15 pm.
11.150	PRL8	RIO DE JANEIRO, BRAZIL. Afternoons and evenings except Sundays. Off at 11 pm.			

Mc.	Call	Location and Schedule
11.705	CXA19	MONTEVIDEO, URUGUAY. Evenings.
11.705	—	FRENCH INDO CHINA. "Radio Saigon"; 8 am to 12 noon.
11.71	VLG3	MELBOURNE, AUSTRALIA; Tahiti beam, news in French, 1:55 am; British beam (English), 2:55 am; Pacific beam (Japanese) 3:30 am; New Caledonia beam (French) 4:30 am; Allied Forces in South Pacific beam (English) 5:30 am.
11.720	CJRX	WINNIPEG, CANADA. Noon to 4:30 pm.
11.72	HSP5	THAILAND.
11.72	PRL8	RIO DE JANEIRO, BRAZIL; "Radio Nacional"; nightly beamed to North America.
11.730	WRUL	BOSTON, MASSACHUSETTS; 11:30 pm to 2 am.
11.730	CBNY	HAVANA, CUBA
11.73	KGEI	SAN FRANCISCO, CALIFORNIA. Evening transmissions.
11.74	HBJ	VATICAN CITY.
11.74	HP5Q	PANAMA CITY, PANAMA. Evenings to midnight.
11.760	TGWA	GUATEMALA CITY, GUATEMALA.
11.77—	DJD	BERLIN, GERMANY. North American beam, evening transmissions.
11.775	MTCY	MANCHURIA.
11.78	GVU	LONDON, ENGLAND. North American beam, 6:30 to 7 pm.
11.78	—	FRENCH INDO CHINA.
11.785	OIX3	LAHTI, FINLAND. 9:15 am.
11.790	HP5G	PANAMA CITY, PANAMA. 10:30 pm to 7
11.79	KGEI	SAN FRANCISCO, CALIFORNIA; 5 pm to 12:45 am.
11.8	DJZ	BERLIN, GERMANY
11.80	JZJ	TOKYO, JAPAN. 7 to 9:30 pm.
11.805	COGF	MATANZAS, CUBA. Afternoon transmissions.
11.81	2RO22	ROME, ITALY. North American beam, 8:30 pm to midnight.
11.830	WCRC	NEW YORK CITY; 5:25 pm to midnight; 6 am to 5:15 pm.
11.84	VLG4	MELBOURNE, AUSTRALIA; Asia beam (Chinese, English, Malay, Dutch) 6:15 am.
11.84	—	MALAYA; "Radio Shonan"; controlled by the Japanese.
11.845	—	VICHY, FRANCE.
11.847	WGEA	SCHENECTADY, NEW YORK; 6:15 am to 5:15 pm; 5:30 pm to 11:30 pm.
11.855	DJP	BERLIN, GERMANY
11.87	VL12	SYDNEY, AUSTRALIA; British beam, (England) 2:55 am.
11.893	WRCA	NEW YORK CITY; 5 to 8:45 am; 3 to 4:45 pm.
11.900	XEW1	MEXICO CITY, MEXICO
11.9	VLG9	MELBOURNE, AUSTRALIA; Asia beam (English) 10:15 am.
11.910	WBOS	BOSTON, MASSACHUSETTS.
11.935	—	"SUDETEN GERMAN FREEDOM"; 7:35 to 7:55 am; 12:15 to 12:30 am; other times.
11.947	—	MOSCOW, USSR. 7:30 to 11 pm.
11.970	FZI	FRENCH EQUATORIAL AFRICA; "Radio Brazzaville"; 3:45 to 4 pm; 11:30 pm to midnight; also heard with news in English at 7:45 pm to 7

# NOW WESTON MODEL 785 INDUSTRIAL CIRCUIT TESTER!

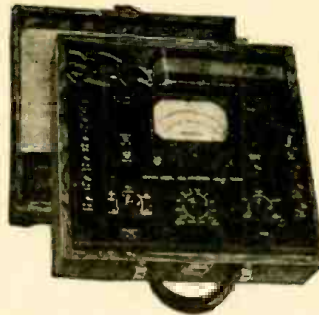

**Tests Insulation and Cable Covering Resistance Values as Well!**

With this new, compact unit which fits into the spare compartment and connects into the ohmmeter circuit with a pair of leads, Model 785 now provides for resistance measurements up to a value of 900 megohms. Thus the broad range coverage of this versatile maintenance tool now is as follows:

**DC VOLTAGE . . . 0-1/10/50/200/500/1000 volts — 20,000 ohms per volt. (\*5000 volt range with external multiplier.)**

**AC VOLTAGE . . . 0-5/15/30/150/300/750 volts — 1000 ohms per volt.**

**DC CURRENT . . . 0-50 microamperes, 1/10/100 milliamperes, 1 ampere and**

**10 amperes (\*ranges above 10 amperes with external shunts).**

**AC CURRENT . . . self-contained ranges 0-5/1/5/10 amperes (\*higher ranges with an external current transformer).**

**RESISTANCE . . . 0-3000, 0-30,000, 0-300,000 ohms, 0-3 megohms, 0 to 30 megohms (self-contained batteries). 0-900 megohms (\*with compact Model 792 Resistance Tester shown in illustration).**

*\*Extra equipment on special order.*

For complete facts on Model 785 write Weston Electrical Instrument Corp., 599 Frelinghuysen Ave., Newark, N. J.

## WESTON Instruments

Mc.	Call	Location and Schedule
12.11	—	ALGIERS, NORTH AFRICA. 1 to 5:30 pm; "Radio France". 4:45 to 5:20 pm.
12.115	ZNR	ADEN, ARABIA. 1 to 1:30
12.130	DZE	BERLIN, GERMANY
12.19	—	MOSCOW, USSR. 6:48 to 7:25 pm.
12.210	TFJ	ICELAND. 7 pm; irregular.
12.455	HCJB	QUITO, ECUADOR, "La Voz de los Andes" (The Voice of the Andes) in English daily at 8 am and 6 and 9 pm. At other times in Spanish.
12.967	WKRD	7:30 to 7:45 am; 8:15 to 8:30 am; 5:45 to 6:15 pm.
12.97	PPH	BRAZIL. 5:45 to 6:15 pm.
14.925	PSE	RIO DE JANEIRO, BRAZIL. North American beam, daily 7 to 8 pm.
15.13	KGEI	SAN FRANCISCO, CALIFORNIA; 1:15 to 2:15 pm.
15.150	WNBI	NEW YORK CITY; 6 am to 4:15 pm.
15.150	WRCA	NEW YORK CITY; 5 to 11:30 pm.
15.155	SBT	MOTALA, SWEDEN. 12 to 2:15 pm; morning transmissions.
15.170	TGWA	GUATEMALA CITY, GUATEMALA. Daytime transmissions.
15.175	—	EL SALVADOR; 1 pm to 7
15.190	KROJ	LOS ANGELES, CALIFORNIA; 3 to 4 pm; 4:15 to 5:45 pm; 6 to 7 pm.
15.190	WKLD	NEW YORK CITY
15.19	OIX4	LAHTI, FINLAND. North American beam; 9:15 to 9:45 am.
15.190	WKRX	NEW YORK CITY; 6:45 to 7 am.

**Help!**  
We need Engineers and Laboratory Asssts.

We're going places in electronics—  
**NOW and after the war.**

**Want to come along?**

If you are not now using your full talents for the war effort, you may participate in the development of new and revolutionary communications methods. Outline your education, experience, marital status and salary requirements. Address

BOX 91, Care RADIO-CRAFT  
25 West Broadway, New York 7, N. Y.

# •LISTENING POST•

Mc.	Call	Location and Schedule	Mc.	Call	Location and Schedule	Mc.	Call	Location and Schedule
15.195	TAQ	ANKARA, TURKEY	15.230	VLG6	MELBOURNE, AUSTRALIA; Western North America, evenings; news at 1:10 am in English.	15.29	KWID	SAN FRANCISCO, CALIFORNIA; 1 to 2:45 am.
15.20	DJB	BERLIN, GERMANY. North American beam; 7 to 9:45 am; 5:50 to 6:30 pm.	15.230	—	KOMSOMOLSK, SIBERIA, USSR. 7:40 to 8:20 am; 10:15 to 10:30 am; 5:15 to 5:40 pm; 6:45 to 7:25 pm; 9:15 to 9:40 pm; 11:15 to 11:40 pm.	15.300	2RO6	ROME, ITALY. Day and night transmissions.
15.200	XGOY	CHUNGKING, CHINA. Asia-Australia-New Zealand beam, 6 to 8:30 am; East Russia beam, 6:30 to 7 am; Japanese beam, 7 to 7:20 am.	15.250	WLWK	CINCINNATI, OHIO; 5:30 pm to midnight.	15.32	VLI3	SYDNEY, AUSTRALIA; Western North American beam, evenings; news in English at 1:10 am.
15.21	WBOS	BOSTON, MASSACHUSETTS; noon to 5:15 pm; 5:30 to midnight.	15.250	—	VICHY, FRANCE. 11:15 am to 1:30 pm.	15.330	WGEO	SCHENECTADY, NEW YORK; 6 to 8 am; 8:15 am to 3 pm; 3:15 to 5:15 pm.
15.220	—	"VOICE OF FREE INDIA". 10 am to 12:05 pm.	15.270	WCBX	NEW YORK CITY; 7 am to 4:45 pm.	15.345	FGA	DAKAR, SENEGAL, AFRICA. 3:15 to 5:20 pm.
15.220	—	AZAD MOSLEM RADIO; 9:30 to 9:45 am.	15.270	WCDA	NEW YORK CITY; 7:30 to 11:30 pm.	15.350	WRUL	BOSTON, MASSACHUSETTS; 7:30 to 11:15 pm.
15.220	—	"NATIONAL CONGRESS RADIO". (INDIA); 12:15 to 12:53 pm.	15.290	WKLJ	NEW YORK CITY	15.430	—	ACCRA, GOLD COAST. Heard testing at 2:20 pm.
						15.465	PRE9	FORTALEZA, BRAZIL; 5 to 9:08 pm; variable.
						15.750	—	MOSCOW, USSR. North American beam, 7:40 to 8:50 am; Sundays, 8:20 to 9:30 am.
						15.980	AFHQ	ALGIERS, NORTH AFRICA. 8 to 9:45 am.
						16.025	AFHQ	ALGIERS, NORTH AFRICA. Variable times.
						17.72	LRA5	BUENOS AIRES, ARGENTINA; off at the present time.
						17.750	WRUW	BOSTON, MASSACHUSETTS; 7:30 to 10:45 pm.
						17.765	—	VICHY, FRANCE.
						17.775	OPL	LEOPOLDVILLE, BELGIAN CONGO. 2:15 to 3:45 pm; 4:15 to 4:30 pm.
						17.780	WNBI	NEW YORK CITY. 9 am to 2:45 pm.
						17.780	WRCA	NEW YORK CITY. 9 am to 2:45 pm.
						17.800	WLWO	CINCINNATI, OHIO; 5:30 to 8:15 pm.
						17.800	TGWA	GUATEMALA CITY, GUATEMALA.
						17.830	WCBX	NEW YORK CITY; 4:55 to 7:45 pm.
						17.830	WCDA	NEW YORK CITY; 7:45 am to 4:45 pm.
						17.84	—	ATHLONE, IRELAND; 8:30 to 9:30 am; 1:30 to 2:15 pm.
						17.850	PRL8	RIO DE JANEIRO, BRAZIL.
						17.870	WNBI	NEW YORK CITY; 8:30 pm to midnight.
						17.915	CR7BI	LOURENCOMARQUES, MOZAMBIQUE.
						18.135	YDA	BATAVIA, JAVA; India beam, ? to noon.
						18.45	HBF	GENEVA, SWITZERLAND.
						18.48	HBH	GENEVA, SWITZERLAND.
						20.040	OPL	LEOPOLDVILLE, BELGIAN CONGO.

## NEW RADIO-CRAFT LIBRARY BOOKS

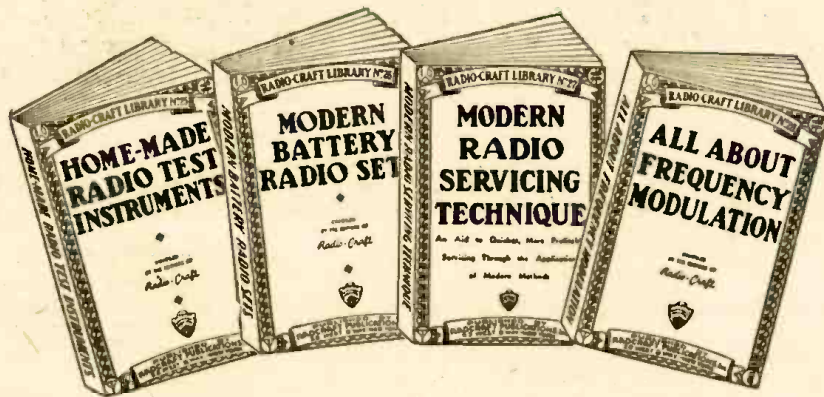

THE four latest books of our well-known RADIO-CRAFT Red Books—Nos. 25, 26, 27 and 28—recently published. These four books are all on timely subjects and we recommend every one of them to you strongly. Now, more than ever, radio education has become a burning question. If you are to be in the National Service; in the Army, Navy or Air Force—practical radio knowledge is of paramount importance. YOU CAN GET BETTER RATINGS AND ADVANCE QUICKER IF YOU HAVE A GOOD RADIO BACKGROUND. Conversely, if you are not with the armed forces, there is a whole of a job to be done at home. With more and more men going into the service, the demand for practical servicemen becomes greater each day. Therefore we say: PROFIT BY THESE UNIQUE BOOKS, WHICH ARE PRICED SO LOW THAT THEY ARE WITHIN THE REACH OF EVERYONE'S PURSE.

**No. 25—Home-Made Radio Test Instruments**  
Outline of Contents: A Low-Cost Signal Chaser—Signal Tracer Test Unit—Simplified Practical Signal Tracer—A Home-Made Infinite Resistance Tube Checker—Build This Direct-Reading V-T Voltmeter—How to Make a Modern V-T Voltmeter—Measuring High Values of A.C. Voltage and Current With a Low-Range Meter—How to Make a Meter-Range Extender—How to Build a Practical Tube Tester and Set-Analyzer Adapter—The Beginner's Simple Volt-Milliammeter—Build This Simplified Neon-Type Test Unit—Midget Oscilloscope—How to Make and Use a Frequency Wobbler—Double Tracing Your Oscilloscope—Home-Made Frequency Modulator.

**No. 27—Modern Radio Servicing Technique**  
Outline of Contents: Elementary Servicing Technique—Correct Procedure for the Servicing Beginner—Elementary Procedure for Servicing Radio Sets—A.F.C. Alignment Made Easy—Dynamic Servicing—Dynamic Testing Simplifies Servicing—Modern Receiver Test Requirements—Servicing Universal A.C.-D.C. Receivers—Servicing "Orphans" and Private-Brand Sets—Emergency Servicing Without Test Meters—Servicing Coils—Servicing R.F. Coils—Servicing Oscillator Coils—General Information—RMA Transformer Color Code—What Causes Echo Fading?—Radio Service Puzzlers.

### SPECIAL SEND-NO-MONEY OFFER

It is not necessary that you send money with order. If you wish to take advantage of our C.O.D. plan, simply cut out the coupon, paste it on a post card and send it to us. Books will be sent to you immediately. All four books are listed uniformly at 50c each. No discount on less than three books. If you wish to take advantage of our special offer, ordering three books or more, we make an unusual low price to you as follows:

3 books—\$1.25 4 books—\$1.50

Do not fail to send coupon today!  
RADCRAFT PUBLICATIONS, INC.  
25 West Broadway, New York 7, N. Y.

**No. 26—Modern Battery Radio Sets**  
Outline of Contents: Beginner's 1-Tube High-Gain All-Wave Receiver—Beginners-Build This 1-Tube Loop Receiver—A "3-in-1" Battery Portable—An Easily-Built "Flewellling Superregenerative" 2-in-1 "Card File" Battery Set—A 2-Tube Superhet. With Pentagrid Regenerative End-Detector—The 4-Tube Superhet. Vacation Portable—The "Lunchbox 5" Battery Portable—"The Seafarer" Loop-Type Boat Radio Set—4-Tube Permeability Portable—An All-Purpose Portable—A Typical Commercial 3-Way Portable (Pilot Models X-1432 and X-1453)—Switch for Varying "C" Bias on Battery Radio Sets—Making a Simple Portable Aerial—Making a Pilot-Light Fuse—Old Auto Sets for New Cars—Using a Loop Portable in Cars—Quasi-Electric Soldering Iron—Lamp Bulbs as Resistors.

**No. 28—All About Frequency Modulation**  
Outline of Contents: The ABC of F.M.—Frequency vs. Amplitude Modulation—Basic Facts About F.M. Broadcasting—Construction—Build This Practical F.M. Adapter—Audio Amplification—F.M. Audio Amplifier, Part 1—F.M. Audio Amplifier, Part 2—F.M. Audio Amplifier, Part 3—F.M. Service—Part 1, Antenna Installation and Service—Part 2, Receiver Alignment and Diagnosis—Part 3, Test Equipment for F.M. Servicing. Construction—Part 1, The How and Why of F.M.—Part 2, The How and Why of F.M.—Theory and Design Considerations of R.F. and I.F. Coils in F.M. Receivers.

RADCRAFT PUBLICATIONS, INC. 943  
25 West Broadway, New York 7, N. Y.

Rush to me by return mail, as per your special offer, the following books: (Check books selected.)

No. 25  No. 26  No. 27  No. 28

I will pay postman \$1.00 (if two books are ordered), \$1.25 for three books, \$1.50 for four books, plus a few cents postage and charges.

WE CANNOT SEND A SINGLE 50c BOOK C.O.D.

NAME .....  
ADDRESS .....  
CITY ..... STATE .....  
Do not fail to send coupon today!  
RADCRAFT PUBLICATIONS, INC.  
25 West Broadway, New York 7, N. Y.

PLEASE PRINT CLEARLY

Save shipping and C.O.D. charges! Check here if you send cash with order. Cash, U.S. new postage stamps, money order, check.) Foreign countries no C.O.D. Add 20% to all prices quoted.

Consolidated Steel Corporation Shipyard at Orange, Texas, boasts one of the most extensive public address systems in the United States. Through it not only music, but also news broadcasts, are brought to the employees.

The system uses 36 loudspeaker trumpets, and has equipment to pick up broadcasts from various parts of the Yard, including the bandstand in front of the main clock gate, from which Thursday afternoon band concerts are broadcast weekly over KPAC at Port Arthur.

The labor-management committee report a noticeable favorable effect on both production and morale.

**WAVES**

(Continued from page 718)

attendance, which brings the number in training and on duty in the Third Naval District to not far short of 5,000.

Whether as straight radiomen manning the typewriters at the Communications Center, as ground-to-plane operators in the control towers, or at the numerous non-radio duties of a WAVE, the trim young ladies of the Navy's Women's Reserve have proved their value even to those skeptics who a year ago snorted at the notion of "sailors in skirts." They are not only freeing men for duty at sea, they are in many cases doing the men's jobs better than they have ever been done before.

**ARMY FIELD PORTABLES**

(Continued from page 722)

break-in box, which connects to the battery plug of the set; this provides means for connecting separate batteries to the set if the standard block battery is unob-

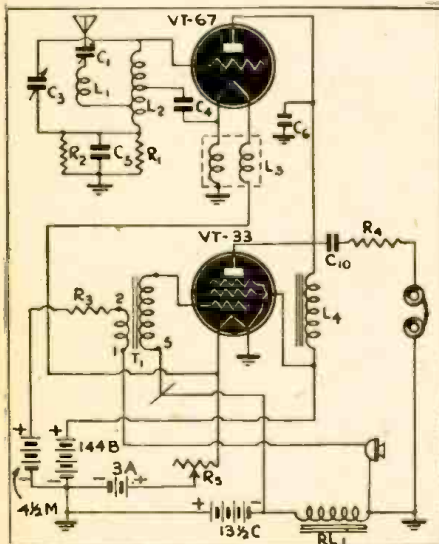

Circuit of the walkie-talkie used as transmitter. The tubes, disguised under Army numbers, are a 30 and 33.

tainable. It also enables meters to be connected to the various circuits for reading the plate voltages and current consumption of the microphone relay and plates. The approximate current readings are:

Receiver plate	21 Ma.
Transmitter plate (modulated)	45 Ma.
Transmitter plate (unmodulated)	35 Ma.
Microphone	35-60 Ma.
Relay	18 Ma.

The controls and components mounted on the front panel of the set, comprise tuning calibration switch, calibration adjuster, filament resistance and switch, filament voltmeter, and microphone and headphone socket.—*Wireless World*, (London)

RCA Victor Division of Radio Corporation of America, announced recently that as of December 31, 1942, the RCA Manufacturing Company, Inc. was merged into the parent corporation.

The merger was effected for purposes of efficiency in corporate organization and production.

**TEMPERATURE CONTROL IN TROPIC FREQUENCY METER**

In this global war, Army and Navy radio transmitters have to work equally as well in the frozen Arctic as in the steaming tropics. But to do this, they have to be adjusted accurately for the effect of changes in temperature and humidity.

The problem of keeping transmitters on their proper frequencies is most difficult in tropical climates. The worst feature is that the wavemeters used to set them right are affected by the heat and humidity, too. They may often be as far off as the transmitters being "corrected."

A tropical wavemeter developed by Philco engineers attacks this problem from a new angle. Instead of attempting the almost hopeless task of making the instru-

ment "weather-proof" they built in a thermostatic control which compensates for changes in temperature. This device, similar in general principles to the thermostat used to adjust the temperature in thousands of American homes, varies the effective length of the wire in the control coil, so that the change in frequency due to change in temperature is exactly neutralized.

The new meter, designed for tropical campaigns, is equally useful where sub-zero temperatures are encountered.

One wonders if it might not be practical to convert the old discarded wavemeters into thermometers. Just note the deviation from the correct frequency at a given temperature, and calibrate same in degrees!

**RADIO FACTS—FOR YOUR FUTURE**



Radios in 28,700,000 homes and 6,800,000 cars must be kept operating.



Radio trained men get interesting assignments, higher ratings and more pay.



Television, now perfected, will be a boom industry requiring many experts.

**Get into RADIO now!**

YOU'LL BE IN BIG DEMAND FOR YOUR SERVICES!

Here is part of a typical help-wanted advertisement which appeared recently: "ELECTRONICS ENGINEERS, LABORATORY ASSISTANTS, PRODUCTION MEN—Well Paying War Job Plus Peacetime Career! Ideal working conditions with expanding manufacturers now at war work and planning peacetime developments. Unlimited opportunity for an important place in a New World of Radio."

**FREE TRIAL LESSON**  
PROVES YOU CAN LEARN QUICKLY

TRAIN YOUR BRAIN—AND LET IT WORK FOR YOU!

DID YOU KNOW?

The Radio Industry is part of the Electronics group of over 10,000 establishments which design, manufacture, purchase and sell a BILLION dollars' worth of equipment annually.

Radio-trained technicians are needed in all these lucrative, high-pay fields: Radio and Broadcasting Industry, the Sound Picture and Public Address Business, Communication by Radio, Wireless and Wire, Facsimile Reproduction, Television, and in many industrial plants.

After the War, many now secret devices employing the electron tube will be revealed to the Public and will have great money-making possibilities.

**YOU GET HOME TRAINING from a real, established Trade School**

For 38 years National Schools has trained ambitious men for Top Pay Trades in Los Angeles. The same technique, the identical shop methods that are so successful in training Radio men at the School, are now available to you by National's Plan of Home Training. You are assigned a progressive series of instructive lessons and you learn step-by-step. It's the Shop-Method Training Plan, developed for men who want practical, easy-to-grasp instruction in Radio.

**YOU CAN BE A SUCCESS IN THE GIANT RADIO INDUSTRY**

You learn how to build, repair and service Radios, learn fundamentals of Broadcasting, basic elements of Electronics; you acquire the ability to professionally handle all types of radio equipment.

**EARN WHILE YOU LEARN**  
You can keep your present job and learn RADIO in all its fascinating branches without further delay. National Schools of Los Angeles has provided an amazing method of training which brings instruction to you right in your home.

FULL DETAILS FOR A PENNY POSTAL

Act Now. You'll be amazed when you receive our Free Trial Lesson, Opportunity Book and full details. No obligation; no cost. Investigate.

**TRAIN FOR FULL RICH REWARDS in these Jobs**  
RADIO EXPERT  
BROADCASTING  
AIRCRAFT—MARINE  
INDUSTRIAL ELECTRONICS  
STUDIO TECHNICIAN  
GOVERNMENT SERVICE



O. K. Ivey, M. Schroeder

"National Schools has done wonderful work for the man who wants to get ahead."  
O. K. Ivey.

National Training Pays  
"Your schooling helped me obtain a swell job."  
M. Schroeder, U. S. Navy.

**2 BOOKS FREE**



**NATIONAL SCHOOLS**



**MAIL FOR FREE LESSON & BOOK**  
National Schools, Dept. R.C.9 (Paste on a 4000 So. Figueroa, Los Angeles, Calif. Penny Postal.)  
Mail me FREE, without obligation, Trial Lesson and Opportunity Book, with full details about RADIO Training at home.  
NAME \_\_\_\_\_ Age \_\_\_\_\_  
ADDRESS \_\_\_\_\_  
CITY \_\_\_\_\_ STATE \_\_\_\_\_

**REQUEST FULL DETAILS**

SOME EXPERIMENTS WITH RADIUM EMANATIONS

Dear Editor:

Thank you for your letter of July 5th, in which you suggested various ways of making audible the emanations of radium.

I have tried out many of these ideas—some of them before hearing from you—but the only one which has given me any definite results to date, is a simple circuit based on the "Floating Grid Relay" as outlined in a recent *Radio Craft*.

I changed the original circuit somewhat, inserting a 500,000 ohm variable resistor in the centre lead of the screen voltage controlling potentiometer, and also a pair of headphones in the plate lead. I coupled this

tube to the input of my amplifier by means of a very small mica capacitor so that any sounds produced in the circuit could be made audible in the speaker.

I tried out various tubes, but the only one that gave me any definite results was the 12A8GT, with two grids "floating"—the one connected to the cap, and the one generally called No. 2. This No. 2 grid when wired into the circuit seemed to have no effect one way or another, so it was left unconnected.

By varying the two potentiometers, a point can be reached whereby the radium emanations are made audible, by approach-

ing the grid cap of the tube with radioactive material, which was placed in a small glass dish, and held in the hand.

Since this effect is most pronounced when wearing the earphones, I have come to the conclusion that the sounds heard are not due to the actual bombardment of the alpha particles, but to a low frequency oscillation which is modulated by the rate of bombardment. The phones apparently form through the hand holding the radium, a capacity feed back, and this is caused to effect the grid by the radium ionizing the air space between the radium and the grid.

The sounds produced are first a humming, and as the radium is brought closer this resolves into a series of individual "pops," these finally developing into a roar when the material is within a half inch or so from the grid terminal.

That the sounds produced are due to the alpha particles from the radium can be easily proven, by merely holding a piece of card or lead foil between the radium and the grid, when all sound ceases. Also if another glass dish of the same size and shape as the first, but containing no radium, is brought near the grid under the same conditions, no sounds are heard.

As yet the circuit is not overly sensitive, since to produce any effect, audibly that is, pure radium bromide, or polonium must be used. I have tried pieces of pitchblende, and Carnotite, as well as other radioactive materials, and these produce no sound in the speaker, although they cause scintillations on zinc sulphide, and cause the electroscope to discharge. I hope by further experimentation to develop a circuit that will react to these materials.

ROBERT A. REED,  
*Lethbridge, Alberta*

(It might be that the better results achieved when wearing headphones are due to a ground return from the radium through body and phone capacity to the battery and cathode circuits of the amplifier.)

The Geiger-Muller type of counter might be imitated, approximated or possibly even improved by the experimenter with nothing more than the usual home work-shop material at his disposal. Other ideas, such as high-voltage fields, partially-ionized space (by heat or ultra-violet rays), might be used.

Has any other experimenter done any work along this line? *Radio-Craft* would be interested in any promising results achieved.)

ARE WE TOO EASY-GOING?

Dear Editor:

I chuckled heartily over the request for pictorial diagrams in the June *Radio-Craft*, and just as heartily approved of your answer. I suppose I shouldn't turn such a cold shoulder on pictorial diagrams—I must have used them once, I don't know when!

Congratulations in general on your magazine, and in particular on the last several paragraphs of the article, "No More New Parts," on Page 529, June, 1943. I've often thought this war, if it accomplishes anything, will knock us out of our heretofore easy-going way of living.

I'm sure the restriction on the sale of parts will do just that to most of the experimenters. More than once I've rewound a 2.5-volt transformer to 6.3 volts—that was before the war—and finished the job satisfied that there were a few things I'd never forget about a transformer.

HAROLD L. LEY, JR.  
*Ashland, Ky.*

SUBSCRIBE NOW TO-

AND RECEIVE FREE THIS DICTIONARY

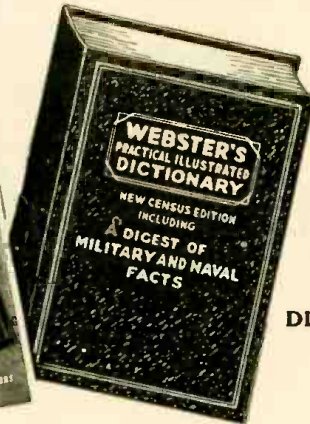

FULL LIBRARY SIZE WEBSTER DICTIONARY 378 PAGES

FIVE MONTHS \$1.00  
TWELVE MONTHS \$2.00

SPECIAL NOTICE TO OUR READERS

Due to wartime curtailment of paper, we are unable to meet the increasing newsstand demand for RADIO-CRAFT. We are therefore making this special introductory offer to our readers. Assure yourself of getting a copy of RADIO-CRAFT monthly by subscribing now and at the same time co-operate in making this wartime measure effective. Don't delay—Send in your order today. Take advantage of our special long-term offer and protect yourself against any possible increase in price by sending \$2.00 for 12 issues.

If you will take advantage NOW of our special subscription offer of five months for \$1.00 or twelve months for \$2.00, we will send you ABSOLUTELY FREE and POSTPAID this 378-page WEBSTER'S PRACTICAL ILLUSTRATED DICTIONARY—useful and instructive to all. This self-pronouncing authoritative dictionary—a brand new work throughout—contains the most up-to-date words now in common use. Over 20,000 definitions in all. In addition, it has the following: List of Largest Cities in the U. S.; List of Principal Cities of the U. S.; List of Principal Cities of Canada; National Parks of the U. S.; Time and its Variations; Tables of Weights and Measures; Presidents of the U. S.; Synonyms and Antonyms; Dictionary of Commerce and Law; Dictionary of Forms of Address; Military and Naval Information (illustrated); Digest of the Purposes of Current Federal Agencies.

THIS IS A TIME LIMITED OFFER

MAIL COUPON TODAY FOR A

SUBSCRIPTION AND DICTIONARY

RADIO-CRAFT  
25 WEST BROADWAY  
NEW YORK 7, N. Y.



-----  
RADIO-CRAFT, DEPT. 943,  
25 WEST BROADWAY, NEW YORK 7, N. Y.  
Gentlemen: Enclosed you will find my remittance for which enter my subscription to RADIO-CRAFT Magazine for the period checked below. Send me ABSOLUTELY FREE and POSTPAID the Webster Dictionary.

5 months — \$1.00       12 months — \$2.00  
 This is a new order       Renewal

NAME .....  
Please Print Clearly

ADDRESS .....

CITY ..... STATE .....

Remit by check or money order; register letter if you send cash or unused U. S. Postage Stamps. (Canadian and foreign orders must be accompanied by an International Money Order.)  
On Canadian orders add 50c for postage; on foreign add 75c.

**WANTS SOUND-ON-FILM**

Dear Editor:

I was much interested in your editorial in the current issue of *Radio-Craft*. In view of the wild promises held out to the public regarding innovations in radio along with television that will be available at the end of the war, your article was very timely.

I am only a layman whose principal diversion is High-Fidelity radio reception. I have never been able to get excited about the prospects of television, as I am of the opinion that the prevailing type of entertainment would be on the order of vaudeville, and there is nothing I want less than vaudeville, or anything near it.

Frequency Modulation holds greater promise but it appears that the owner of a FM set will have to be satisfied with local programs. If such is the case, the avid listener has little to look forward to.

*Radio-Craft* had, some months ago, an article on wide-range "sound-on-film." The possibilities of such film for reproduction of music sounded impressive and I am sure attracted much attention.

I was wondering if you could run another article on this subject to let music lovers know if the company is going along with the plans to put such film on the market, and if radio manufacturers plan to include the reproducing photo-electric feature in new model radios?

Obviously, the sound-on-film would revolutionize that phase of reproduction and might furnish the local FM transmitting stations with worthwhile programs.

A lot of persons like myself—who are not interested in radio servicing—read your magazine for the reason that it carries articles of interest to the layman. We would like to be kept fully abreast of the progress of this sound-on-film idea.

TAYLOR VEAZEY,  
Washington, D. C.

**LIKES OUR OLD ISSUES**

Dear Editor:

Well over a month ago I requested information about a receiver, described in one of your earlier magazines. I regret that I have neglected to thank you for your kind cooperation and swift service.

I certainly had not been keeping up with your present publication. I have a large stack of old editions over which I have spent many an enjoyable evening. However, I now "keep tab on" your latest publications, reading each one from cover to cover and consuming information which I never thought could be had in a magazine. I think it is the best radio publication on the market at that price.

Keep up the fine work and thank you again.

PAUL HEFFLEY,  
Connellsville, Penna.

**HEADPHONES CHEER VETS**

Headphones which have been hanging in attics since the days of the crystal set are now going into action to relieve the monotony of convalescence for wounded soldiers from Tunisia, according to a report received last month from Butler, Pennsylvania.

The soldiers, hospitalized at the DeShon General Hospital near that city, were unable to use loudspeaker radio in the wards, the noise being objectionable to some patients. A campaign for headphones was launched by a prominent Pittsburgh professional and business women's club in cooperation with Radio KDKA. At last report more than 100 headsets have been delivered to the DeShon patients.

**EXPERIMENTERS**

The war has made a terrific inroad in practically all electrical and mechanical supplies. We are fortunate in being able to offer difficult to obtain merchandise listed below. As supplies are limited, we suggest that you order immediately before certain of the items are sold out.

All of the attractive items listed here are brand new, except where indicated. ALL are in PERFECT WORKING ORDER. In many cases, the parts alone total more than the price we are asking. Satisfaction guaranteed or your money back.

ORDER FROM THIS PAGE. Use our convenient coupon. Include sufficient extra remittance for parcel post charges, otherwise order is sent express collect. Any excess will be refunded. All C.O.D. shipments require 20% deposit. NO C.O.D. shipments on orders for less than \$3.00. If full remittance accompanies order, deduct 2% discount. Send money order, certified check, or new U. S. stamps. No C. O. D.'s to foreign countries.

**ORDER TODAY LIMITED QUANTITIES PROMPT SHIPMENTS ASSURED**

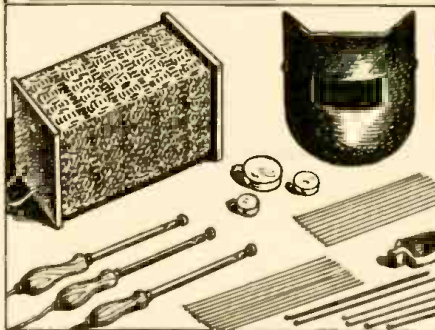

**THE MAGIC ELECTRIC WELDER**

Here is one of the most compact, practical welders we have ever seen. Anyone can use it for shop, farm and home repairs. WELDS, BRAZES, SOLDERS, CUTS ALL METALS. ANYONE CAN OPERATE IT. Repairs steel, cast iron, aluminum, brass, copper, bronze, etc. Complete with power unit, flame and metallic arc attachments. (Really two welders in one). Carbons, fluxes, rods, mask included. Just plug it in any electric outlet. 110 volts AC or DC. For hobbyist or professional. GET IN ON THE GREAT WELDING BOOM. This fine set quickly teaches you welding. Low cost to operate—about 5c an hour. COMPLETE SAFETY is assured. No fumes with this outfit. SET COMES COMPLETE—nothing else to buy.

Used by the U. S. Navy, American Tel. & Teleg. Co., Eastman Kodak Co., Bell Laboratories, etc. BRAND NEW OUTFIT. Guaranteed for one year. Complete simple instructions with each set.

ITEM NO. 158 YOUR PRICE \$19.95

**WESTERN ELECTRIC BREAST MIKE**

This is a fine light-weight aircraft carbon microphone. It weighs only 1 lb. Mike comes with breast-plate mounting and has 2-way swiveling adjustment so that it can be adjusted to any desired position. There are 2 woven straps, one goes around neck, the other around chest. Straps can be snapped on and off quickly by an ingenious arrangement.

This excellent mike can be adapted for home broadcasting or private communication systems. By dismantling breastplate, it can be used as desk mike. Comes complete with 6-foot cord and hard rubber plug. Finished in sherrardized plate, non-rustable.

THIS IS A BRAND NEW MIKE. IT HAS NEVER BEEN SOLD AT SUCH A LOW PRICE BEFORE. ORIGINAL LIST PRICE \$15.00. Shipping weight, 2 lbs.

ITEM NO. 152 YOUR PRICE \$2.55

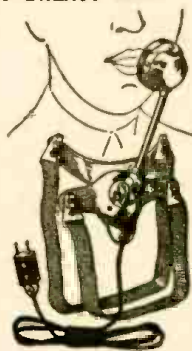

**POWERFUL ALL-PURPOSE INDUCTION MOTOR IDEAL FOR EXPERIMENTERS—101 USES**

Sturdily constructed to precision standards, this self-starting reversible shaded pole A.C. induction motor is powerful enough for a number of uses. Some of these are: Automatic Timing Devices, Current Interrupters, Electric Fans, Electric Chimes, Window Displays, Photocell Control Devices, Electric Vibrators, Small Grinders, Buffers and Polishers, Miniature Pumps, Mechanical Models, Sirens, and other applications.

Consumes about 15 watts of power and has a speed of 3,000 r.p.m. When geared down, this sturdy unit will constantly operate an 18-inch turntable loaded with 200 lbs. dead weight—THAT'S POWER! Dimensions, 3" high by 2" wide by 1 1/2" deep; has 4 convenient mounting studs; shaft is 3/8" long by 3/16" diameter, and runs in self-aligning oil-retaining bearings. Designed for 110-20 volts, 50-60 cycles, A.C. only.

ITEM NO. 147 YOUR PRICE \$1.95

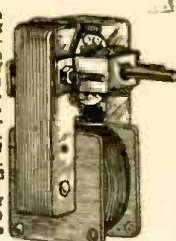

**ULTRA MAGNET**

LIFTS MORE THAN 20 TIMES ITS OWN WEIGHT

**LITTLE GIANT MAGNET.** Lifts 5 lbs. easily. Weighs 4 oz. Made of ALNICO new high-magnetic steel. Complete with keeper. World's most powerful magnet ever made. The experimenter and hobbyist will find hundreds of excellent uses for this high quality permanent magnet. Measures 1 1/2" x 1 1/2". Shp. Wt. 3/4 lbs.

ITEM NO. 159 YOUR PRICE \$1.15

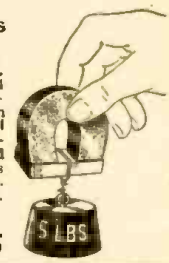

**VARIABLE SPEED UNIVERSAL MOTOR For 110 Volts, A.C. or D.C. All Nickel Plate**



Edison Dictaphone motor 1/50 H.P. Used but in excellent condition. For buffing, polishing, drilling, sawing, runs phonographs, fans, models, blowers, lathes, etc. Special control permits variable speeds up to 1500 r.p.m. 5/16" shaft extends from both sides of motor. Cast iron base has 3 screw mounting holes. Height 4 1/2"; length 7 1/4"; width 5 1/2". Shaft is 1 1/4" long on one side. Shp. Wt. 8 lbs.

ITEM NO. 157 YOUR PRICE \$3.45

**POWER ADJUSTABLE RHEOSTAT**

Here is an excellent rheostat used especially to regulate speeds of small motors, such as our Handy Workshop Outfit. This rheostat can be used in connection with motors up to 1/20 H.P. This fine rheostat is wire-wound on porcelain insulation. The black enamel steel casing is perforated for ventilation. Adjustable handle regulates speed of motor easily and smoothly. Size 6 1/2" x 2 3/4" overall. Shp. Wt. 2 lbs.

ITEM NO. 153 YOUR PRICE \$1.45



**AMAZING BLACK LIGHT!! Powerful 250-Watt Ultra-Violet Source**

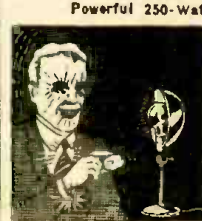

The best and most practical source of ultra-violet light for general experimental and entertainment use. Makes all fluorescent substances brilliantly luminescent. No transformers of any kind needed. Fits any standard lamp socket. Made with special filter glass permitting only ultra-violet rays to come through. Brings out beautiful opalescent hues in various types of materials. Swell for amateur parties, plays, etc. to obtain unique lighting effects. Bulb only. Shp. Wt. 1 lb.

ITEM NO. 87 YOUR PRICE \$2.45

**WATTHOUR METER**

Completely overhauled and ready for immediate service. Designed for regular 110-volt, 60 cycle 2-wire A.C. circuit. Servicemen use it in their shops to check current consumption of soldering irons, etc. Keeps costs down. If dismantled, the parts alone would bring the price. The elaborate gear train could be used as a counter on machines of various kinds. Simple to install; 2 wires from the line and 2 wires to the load. Sturdily constructed in heavy metal case. 8 1/2" high, 6 3/4" wide, 5" deep. Westinghouse, G. E. or Ft. Wayne makes. Shp. Wt. 14 lbs.

ITEM NO. 33 YOUR PRICE \$4.95



**HUDSON SPECIALTIES CO., 40 West Broadway, N. Y. C.**

IT'S EASY TO ORDER—CLIP COUPON—MAIL NOW ORDER FROM THIS PAGE.

HUDSON SPECIALTIES CO., 40 West Broadway, Dept. RC-9-43, New York, N. Y.  
I have checked below the numbers of the items I'm ordering. My full remittance of \$..... (include shipping charges) is enclosed. NO C.O.D. ORDERS UNLESS ACCOMPANIED WITH A DEPOSIT.  
OR my deposit of \$..... is enclosed (20% required). ship order C.O.D. for balance. NO C.O.D. ORDER FOR LESS THAN \$3.00. (New U. S. stamps, check or money order accepted.)  
Circle Item No. wanted: 33 87 147 152 153 157 158 159

Name ..... Address .....  
Please Print Clearly  
City ..... State .....  
Send remittance by check, stamps or money order; register letter if you send cash or stamps.

**None better then  
or Now!**

WHEN Victory is ours and better amplifiers are designed and perfected, you can bet your last dollar on the engineering skill of Amplifier Co. of America. Basic Design is all important. No new developments or improvements have come along during the last few years which would make our popular line of direct-coupled amplifiers obsolete.

Amplifier Co. of America, the recognized leader in improvements and modern direct-coupled P.M.-A.M. amplifiers, has made an outstanding contribution to the Sound Industry by making available their Amplifier Manual specially prepared by A. C. Shaney, Chief Engineer.

**Explains the theory and practical application of:**

- Variable Speed Non-Overloading Push-Pull Expansion;
- Non-Frequency Discriminating Scratch Suppression;
- Push-Pull Balanced Direct-Coupled Amplification;
- Push-Pull High-Frequency Equalization; Push-Pull Low-Frequency Equalization; Push-Pull Volume Compression; Automatic Volume Limitation; Automatic Volume Control; Calibrated V.U. Indicator; Audio Spectrum Control; Remote Control.

If you are interested in the latest audio developments, you can't afford to be without this complete compilation of authentic articles on Direct-Coupled Amplifiers. 32 pages 8 1/2" x 11". Over 100 diagrams and illustrations.

Printed to Cover Cost of **25c** Send Stamps  
Printing and Mailing or Coin

**AMPLIFIER CO. of AMERICA**

396 BROADWAY, NEW YORK, N. Y.

**GEOPHYSICAL  
PROSPECTING  
PRINTS  
(TREASURE  
FINDERS)**

**50¢ EACH  
7 FOR  
\$3.—**



LAND-MINE LOCATOR

With any one of the modern geophysical methods described in the Blue-Print patterns, radio outfits and instruments can be constructed to locate metal and ore deposits (prospecting); finding lost or buried treasures; metal war relics; sea and land mines and "dufs"; mineral deposits; subterranean water veins; oil deposits (under certain circumstances); buried gas and water pipes; tools or other metallic objects sunken in water, etc., etc.

- Folder No. 1. Radiodetector Pilot. Construction and use of 2 tube transmitter and 3 tube receiver. Rejected wave principle. Visual and aural signals.
- Folder No. 2. Harmonic Frequency Locator. Radiates low frequency wave to receiver. Aural signals.
- Folder No. 3. Boat Noise Indicator. 2 oscillators. Visual and aural signals.
- Folder No. 4. Radio Balance Surveyor. Balanced loop principle. Modulated transmitter. Visual and aural signals.
- Folder No. 5. Variable Inductance Monitor. Inductance principle. Aural signals.
- Folder No. 6. Hughes Inductance Balance Explorer. Bridge principle. Aural signals.
- Folder No. 7. Radiodine Prospector. Balanced loop principle. Very large field of penetration. Aural signals.

Each set of blueprints and instructions enclosed in heavy envelope (9 1/2" x 12 1/2"). Blueprints 22" x 34"; eight-page illustrated 8 1/2" x 11" folder of **50c** instructions and construction data

The complete set of seven folders  
Shipping weight 2 lbs. (add 25¢ for shipping anywhere in U.S.A.) **\$3.00**

Send Stamps, Cash or Money Order to

**TECHNIFAX**

1917 S. STATE ST. CHICAGO, ILL.

**TECHNIFAX** 1917 So. State, Chicago, 16, Ill.

Enclosed herewith \$..... for which mail to address below:

- Treasure Finder No. 1, 2, 3, 4, 5, 6, 7.
- Complete set of seven folders.

NAME .....

ADDRESS .....

CITY ..... STATE ..... RC-943

**AMERICAN SHORT WAVE**

American short-wave broadcasters have won the battle of South America from the numerous Axis stations who nightly beam their broadcasts in that direction, it was reported last month by the Office of the Co-ordinator of Inter-American Affairs.

United States networks average 420 hours of programs per week, beamed into South America from 10 shortwave stations in Spanish, and 3 in Portuguese. To secure complete coverage, 3 frequencies are used simultaneously.

Latin America listens on more than four million receivers. Evidence is that they are increasingly tuned to the North American and British broadcasts, and that the pre-war popularity of the German and Italian features has practically disappeared. News commentaries are considered the most important items, but quiz programs, question-and-answer features, anti-Axis plays and programs, and music also have their place in the programs.

The popularity of American and British shows is shown further by the arrangements made and now being made to put them over South American local stations. Mutual Broadcasting System has just signed a contract with Radio Mil, of Mexico City, for a co-operative interchange of programs, and the British Broadcasting Co. has no less than 6 representatives in South and Central America, arranging for additional BBC outlets.

CIAA prepares a daily average of about 40,000 words of news and commentary in three languages for the Latin American service. New plans include short news broadcasts every hour, as well as the regular 15-minute news programs.

**CRAMPTON PARTS LIST**

AS we have been vigorously reminded by a number of readers, the Parts List of the P.A. System by Arthur A. Crampton, in the July issue was not printed. Here it is:

**Parts List**

- R1—5 megs.
- R2, R6—1,000 ohms
- R3—1.5 megs.
- R4—0.25 meg.
- R5, R7, R8—50,000 ohms
- R9, R10, R12—100,000 ohms
- R11, R13—0.33 meg.
- R14—100 ohms
- R15, R16, R17—0.5 megohm column controls
- C1—10 mfd. 25-volt
- C2, C9, C10—0.1 mfd. 400-volt
- C3, C11—0.01 mfd.
- C4, C6, C7, C8—8 mfd. 450-volt
- C5—4 mfd.
- C12—250 mfd.
- C13, C14—0.02 mfd. paper

There was also a mistake in the drawing of the oscillator, the lead to the 76 plate and grid being taken from the filament side, instead of the line side, of the filament dropping resistor.

**B**ECAUSE it is considered a more practical tube to produce than the 5Y3-GT/G, unrestricted manufacture of the Type 5Y3-G tube was allowed today by the WPB through an amendment to Limitation Order L-76. The order previously permitted manufacture of Type 5Y3-GT/G, but experience showed that this tube did not always perform satisfactorily, and difficulty was experienced in its manufacture.

The change will not add appreciably to present civilian tube supplies because of limitations on available materials, according to the Radio Division of the War Production Board.

**Tubes and Parts**

**★ No Priority Required**

**★ Immediate Delivery**

Write for our latest catalog listing Tubes, Condensers, Speakers, Volume Controls, Vibrators, Resistors, Transformers and hundreds of hard-to-get replacement parts at unbelievably low prices!

**RADIO WAREHOUSE MARKET**

364 Wooster Ave. Akron, Ohio

**Index to advertisers**

Allied Radio Corp.	758
Audel & Company	Back Cover
Audiograph	749
Amplifier Company of America	766
Burnstein-Applebee	757
Cannon Company, C. F.	753
Chartered Institute of America	757
Cox, John A.	757
Echophone	741
General Electric Co.	748
Gold Shield Products	755
Hallcrafters, Inc.	707, 708
Harrison Radio	755
Henry Radio	757
Hudson Specialties	765
Lancaster, Allwine & Rommel	757
McGee Radio	760
McGraw-Hill	767
Meissner Manufacturing Co.	751
National Radio Institute	705
National Schools	763
National Union Corp.	Inside Back Cover
Nelson Company	760
Onan & Sons, D. W.	753
Opportunity Adlets	755
Pioneer Gen-E-Motor	747
Popular Homecraft	757

**RADIO SCHOOL DIRECTORY**

Page 768

- Candler System
- Capitol Radio Engineering Institute
- Commercial Radio Institute
- Lincoln Engineering School
- Mass. Radio School
- New York Y.M.C.A. Schools
- RCA Institutes
- Radio-Television Institute

Radcraft Publications, Inc.	745, 762, 764
Radio Warehouse Market	766, 755
Sprague Products Co.	739
Sprayberry Academy of Radio	756
Supreme Instruments	753
Supreme Publications	Inside Front Cover

Sylvania Electric Co.	750
Technifax	760, 766
Teleplex	757
Triplet Electrical Instrument Co.	752
University Laboratories	760
Universal Microphone	754
Weston Electrical Instruments	761

(While every precaution is taken to insure accuracy, we cannot guarantee against the possibility of an occasional change or omission in the preparation of this index.)



# BOOK REVIEWS

**RADIO ENGINEER'S HANDBOOK**, by Frederick Emmons Terman. Published by the McGraw-Hill Book Co. Flexible leatherette cover, 6 x 9 inches, 1019 pages. Price \$6.00.

Possibly the best possible review of this work would be to simply state that Terman has written an engineer's handbook, as the author's reputation is such that the very fact of its publication is sufficient to assure it of a place among the standard works.

The purpose, according to the author, is "to provide a reference book summarizing the body of engineering knowledge that is the basis of radio and electronics."

The book keeps well to the subject of radio. While many of the newer electronic developments find their place, it is only as they are related to radio applications.

One of the more interesting sections is the last one, "Measurements," which covers the ground with considerable thoroughness.

Thoroughness, indeed, is one of the primary objects of the book. The author states that more than two thousand technical articles were reviewed during its preparation. The fifteen hundred footnotes referring to published articles cover practically all the pertinent engineering literature that bears on any particular subject dealt with in the text.

Another objective which has been successfully attained is that of using the space at hand for the presentation of all the important facts about a subject in brief handbook form, without letting any of it be crowded out by the inclusion of introductory material which may trespass on the field of ordinary good text-books.

An additional convenience is the index of authors which is provided in addition to the very complete index by subjects.

One interesting effect of the introduction of this new book is that more than one engineer, worker and student will have to refer again to the work he has always known as "Terman" in order to determine its proper title, by which it will now have to be known, if ambiguity is to be avoided.

**BASIC RADIO**, by J. Barton Hoag. Published by D. Van Nostrand Co. Stiff leatherette covers, 5½ x 8½ inches, 379 pages. Price \$3.25.

The name might suggest to some a highly-simplified and elemental text, along the line of other "Basic" subjects. Such is not the case. To the author, "basic" means those tube circuits on which the radio art depends, those circuits which have been tried and tested through use, and are now fundamental. These are studied to the exclusion of other interesting developments whose special applications or untried status excludes them from the "basic" category.

The book is by no means old-fashioned or conservative. Indeed, a number of circuits appear on its pages which have never before been submitted to the beginning student. These include frequency modulators, square-wave apparatus and pulse generators, oscillators using the special ultra-high-frequency tubes, electronic switches, thyatron inverters, etc.

Probably the most striking feature of the work is its ability to explain unfamiliar and not-too-simple apparatus in clear and understandable terms. Possibly it is because of this that the author confidently attempts such subjects as square-wave generators and frequency modulators in an elementary book.

The text is written in the simplest manner possible. A knowledge of ordinary arithmetic is all that is required to understand the problems involved. This combination of scope and simplicity may well make this book the coming standard popular work on radio for more serious readers.

**EXPERIMENTS in ELECTRONICS and COMMUNICATIONS ENGINEERING**, by E. H. Schultz and L. T. Anderson. Published by Harper & Brothers. Stiff cloth covers, 6½ x 9 inches, 381 pages. Price \$3.00.

The authors of this text are instructors in electrical engineering in the Illinois Institute of Technology. A Signal Corps Training School has been operated by the Institute, and the book was prepared to serve as a guide for laboratory work undertaken in connection with the course. Since the trainees spend almost one-third of their time in the laboratory, a manual covering this work must be fairly extensive.

According to the sub-title, it covers basic circuit theory, electronics, communication networks, radio and ultra-high-frequency techniques. The book is divided into 14 chapters. The first two are introductory, dealing with laboratory technique and laboratory equipment, and are designed to familiarize the student with the equipment with which he will work and the methods of investigation followed in standard laboratory practice.

The remaining 12 chapters are devoted to experiments, averaging roughly 10 experiments per chapter. Experiments range from elementary resistance measurement to investigation of wave propagation at ultra-high-frequencies.

The chapter on oscillators also recognizes the importance of high frequencies. There are experiments with magnetrons, positive-grid and velocity-modulated oscillators, as well as with transitron types and the standard radio and audio oscillating circuits.

The adaption of this book to modern technique and modern training methods should make it very useful to instructors and students.

**PRACTICAL RADIO for WAR TRAINING**, by M. N. Beitman. Published by Supreme Publications. Flexible fiber covers, 6 x 9 inches, 336 pages. Price \$2.95.

The complaints of more than one student with no previous knowledge of radio, that his text tells him everything but "how many turns of what size wire on what size form will bring in a certain station," are met in this book. Designed for home study, for radio beginners' courses, pre-induction

radio classes and war plant radio training, it stresses the practical side of radio. The new trainee is not scared off at the start with several chapters of theory which apparently have nothing to do with radio.

This book starts Chapter 1 with a standard small home radio receiver, and tells the trainee how to get the knobs off it and get it out of the cabinet. For 32 pages he is instructed on radio parts, radio tools, soldering and splicing, and not until he begins to feel at home with a receiver, and is sure that he is actually engaged in a radio course, is he introduced to the simple mathematics required in this type of course.

Excellent printed on paper much better than is usually found in a book of this type the text is rendered attractive by the large number of photographic illustrations. It will be welcome by that large group who, because of insufficient education, lack of familiarity with the practical aspects of radio, or other reasons, find even the so-called "elementary" textbooks on the subject incomplete and confusing.

## NOW—A REALLY HIGH-POWERED— Radio Engineering Library

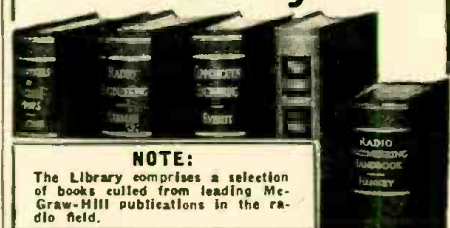

**NOTE:**  
The Library comprises a selection of books culled from leading McGraw-Hill publications in the radio field.

- especially selected by radio specialists of McGraw-Hill publications
- to give most complete, dependable coverage of facts needed by all whose fields are grounded on radio fundamentals
- available at a special price and terms

THESE books cover circuit phenomena, tube theory, networks, measurements, and other subjects—give specialized treatments of all fields of practical design and application. They are books of recognized position in the literature—books you will refer to and be referred to often. If you are a practical designer, researcher or engineer in any field based on radio, you want these books for the help they give in hundreds of problems throughout the whole field of radio engineering.

**5 VOLUMES, 3319 PAGES, 2289 ILLUSTRATIONS**

1. Eastman's FUNDAMENTALS OF VACUUM TUBES
2. Terman's RADIO ENGINEERING
3. Everitt's COMMUNICATION ENGINEERING
4. Hund's HIGH FREQUENCY MEASUREMENTS
5. Henney's RADIO ENGINEERING HANDBOOK

10 days' examination. Easy terms. Special price under this offer less than books bought separately. Add these standard works to your library now; pay small monthly installments, while you use the books.

**10 DAYS' FREE EXAMINATION—SEND COUPON**

McGraw-Hill Book Co., 330 W. 42nd St. New York 18

Send me Radio Engineering Library, 5 vols., for 10 days' examination on approval. In 10 days I will send \$3.00 plus few cents postage, and \$3.00 monthly till \$24.00 is paid, or return books postpaid. (We pay postage on orders accompanied by remittance of first installment.)

Name .....

Address .....

City and State .....

Position .....

Company ..... RC-9-43

# RADIO SCHOOL DIRECTORY

## U. S. ARMY OPERATES BROADCAST STATIONS

A CHAIN of 23 U. S. shortwave stations and 90 overseas longwave transmitters are operated by the Special Service Division of the Army Service Forces, War Dept. testimony at hearings before the House Appropriations Committee revealed. Facilities are used for the information and entertainment of troops.

"We found that the troops overseas need radios," said Gen. F. H. Osborn, SSD chief, "and they depend on radios for news and information, particularly in isolated posts. We found, for instance, that all through the Aleutians the stations in Alaska did not reach the far Aleutian Islands and the only

radio they were hearing was the Japanese radio, broadcasting in English, and they did not get any American news."

Gen. Osborn related that the War Dept. began to put up small stations, with a radius of only a few miles. Five are operating in the Aleutians, and nine more are going up. At present, the Special Service Division provides the stations with 34 programs a week.

About \$21,100,000 of the money requested for radio equipment for overseas forces would be used to buy small radio sets for servicemen next year, and about \$800,000 to pay for broadcasting stations.—*Broadcasting*

## SPRAGUE CO. CORRECTION THOSE "IMPS" DID IT!

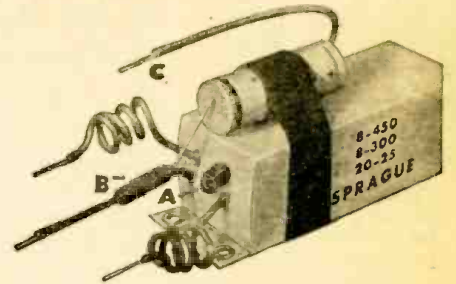

One of those hard-to-catch typographical errors that make life miserable for printers did an "Imp" job on a recent Sprague Condenser advertisement appearing in this publication.

This advertisement contained the accompanying illustration demonstrating how a Sprague UT-8 8 mfd. 450 volt Atom Midget dry electrolytic could be used to replace the 8 mfd. 450 volt section of a 3-section condenser rated at 8 mfd. 450 v., 8 mfd. 300 v., and 20 mfd. 25 v. So far, well and good—but the trouble came when our little pet Diagram mixed up the "B" and "C" portions of the accompanying directions. Actually, they should read as follows:

- (A) Cut lead to defective section and tape end.
- (B) Connect cathode (—) side of Atom to common minus lead of multi-section condenser.
- (C) Connect cut circuit lead to positive (+) side of Atom.

By following this procedure, you'll find that it is seldom necessary to replace an entire multi-section condenser simply because one section has gone bad. Most defective sections can be replaced by using a Sprague Atom of the proper capacity and voltage in the manner illustrated.

## "IMPLOSIONS"

IN the days before the war that now seem so far away I often heard and read of the unpleasant results of implosions (to implode is to burst inwards instead of outwards) of cathode-ray tubes. Since then my job has been concerned to a large extent with CRTs of all sorts and sizes. I have known a good few broken, but, so far—and here I touch wood firmly—I have never seen or heard an implosion. Possibly that is because most of the breakages that have come my way have been caused by the splitting off of one of the "horns" that contain the leads to the X and Y plates. When one of these is broken off, the entrance of air is to a large extent controlled by the comparatively small hole in the glass that is opened to it; there is not the same wild rush that there would be if the screen or the body of the tube were splintered. That would probably cause the father and mother of a bang. I am told that in that case the "electron gun" assembly has a way of shooting out *en bloc* like a shell from the other sort of gun. The biggest implosion that I have come across during the war was that of a transmitting tube, of which the glass envelope, more than an eighth-inch thick, was cut through by an arc-over. There was not much noise, and there cannot have been any high-velocity flying fragments, for the damage done was nil, save to the tube itself. Even its push-pull partner was uninjured. Curiously enough, the glass of the bulb was cut off near the base in an absolutely straight line, just as if someone had taken a diamond to it. Has anybody had first-hand experience of an implosion of a good-sized cathode-ray tube?—*Diallist (Wireless World)*

# Radio School Directory

TO OUR READERS—NOW IS THE TIME TO TAKE UP RADIO!

NOW, more than ever before America needs trained radio men. The Army, the Navy and the Air Force are continuously on the lookout for men who have had training in radio. Scores of war industries require radio men in various capacities throughout the country. There now is and there will be a great shortage of radio men for years to come. Reputable schools of Radio advertise to help you.

## PRE-INDUCTION RADIO COURSES

Special Fall Course for High-School Students—of Special Interest to 17-year-old boys who may be called into Military Service.

NEW CLASSES NOW STARTING  
 • RADIO OPERATING • CODE  
 • RADIO SERVICING  
 • ELECTRONICS • TELEVISION  
 New York Y.M.C.A. Schools  
 4 W. 64th Street New York City

## COMMERCIAL RADIO INSTITUTE

A radio training center for twenty-three years.

### RESIDENT COURSES ONLY

Pre-Induction, Broadcast, Service, Aeronautical and Radio telegraphy classes now forming for October 4th. Literature upon request.

Dept. C., 38 West Biddle St., Baltimore 1, Md.

## RADIO-TELEVISION VITAL to War Effort

Enroll now with new groups. Opportunity under war conditions and real future in peacetime.

RADIO-TELEVISION INSTITUTE  
 Dept. R. C.  
 480 Lexington Ave., New York, N. Y.

## LES Correspondence Courses in RADIO and ELECTRICAL ENGINEERING

**ELECTRICAL ENGINEERING** Get good grasp of wide electrical field. Prepare yourself, at Low Cost, for secure future. Modern, simplified, you can understand quickly.  
**RADIO ENGINEERING** Extra fine course in radio, public address, phono-electric work. Trains you to be super-service man, real vacuum tube technician. Servicemen needed badly. Diploma on completion. Tuition \$25, other course. Deferred payment plan.  
**FREE** Get copies of school catalogs, student magazines, complete details. SEND NOW!

LINCOLN ENGINEERING SCHOOL Franklin Stn., Box 61-C55 WASHINGTON, D. C. (Formerly at Lincoln, Nebr.)

### RADIO OPERATORS WANTED

Be a "key" man. Learn how to send and receive messages in code by telegraph and radio. Army, Navy and Commerce needs thousands of men. Good pay, adventure, interesting work. Learn at home quickly through famous Candler System. Write for FREE BOOK.

**CANDLER SYSTEM CO.**  
 Dept. J.K., Box 928  
 Denver, 1, Colo., U. S. A.

## TODAY is the time to turn your RADIO JOB into a SECURE POSITION!

Do You Want a BETTER JOB?—A Secure Future? NOW is the time to prepare yourself for a lasting, profitable Career in Radio Engineering!

The sure way to success is to build your future on a sound foundation of *knowledge and ability* . . . and the ability that you develop *now* is your assurance of a steady, sure income and a permanent job that will outlast the temporary employment conditions that exist today. CREI technical training is designed to do just *one thing*—to increase your ability, enabling you to hold the more responsible positions which lead to higher salaries.

**WRITE TODAY!** If you are a professional or amateur radio man and want to make more money—let us prove to you we have something you need to qualify for the better job opportunities that can be yours. To help us intelligently answer your inquiry—please state briefly your education, radio experience and present position.



## CAPITOL RADIO ENGINEERING INSTITUTE

Dept. RC-9, 3224 16th St., N. W., Wash. 10, D. C.

# LEARN RADIO

Pre-Induction Courses for beginners lead to higher ratings in Army and Navy. Catalog free.

**MASS. RADIO SCHOOL**  
 18 BOYLSTON ST., BOSTON, MASS., Est. 1899

## RADIO TECHNOLOGY

RCA Institute offers an intensive two-year course of high standard embracing all phases of Radio and Television. Practical training with modern equipment. Also shorter specialized courses in Commercial Radio Operating, Radio and Television Servicing, and Aviation Communications. For Free Catalog write Dept. RC-43.

**RCA INSTITUTES, Inc.**  
 A Radio Corporation of America Service  
 75 VARICK STREET NEW YORK 13, N. Y.

FROM HUNDREDS OF MILES AT SEA CAME

# THE ALARM THAT SAVED MIDWAY!

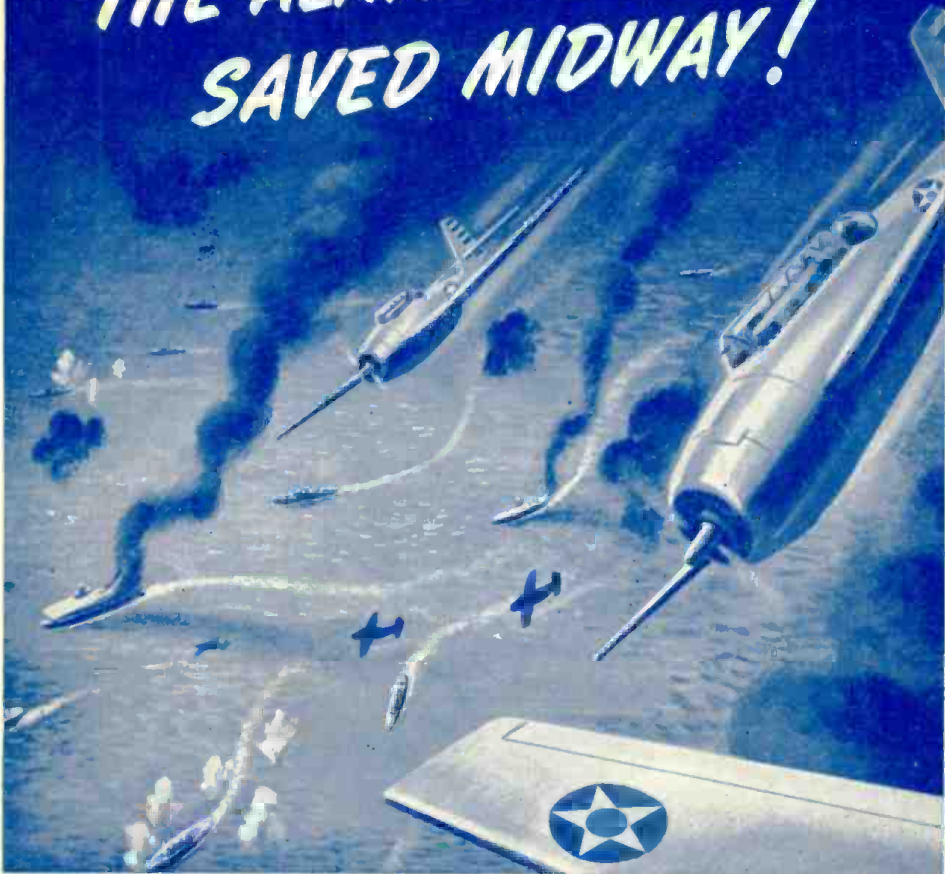

*Midway was ready* when the Jap attempt to capture this strategic U. S. outpost came June 4 to 7, last year. Long before the Jap fleet of battleships, carriers, cruisers, destroyers and transports could bring their big guns into range—vigilant patrol planes with modern radio communications equipment had sounded the alarm. Many miles from Midway's shores American planes blasted their fleet... drove their survivors into a frantic homeward retreat.

**R**EPEATEDLY it has been said—"this war is different". Yes, different because, on land, at sea and in the air, battles are being planned and fought with weapons never before available to our fighting men. Among these is the electronic tube. It is reassuring to know that no nation is making wider or better use of this great weapon of modern warfare than the U. S. A. To help serve the vast requirements of our Army and Navy National Union, for example,

is producing electronic tubes on a scale far exceeding its peace-time peak. Yet, dramatic as are the achievements of electronics in war, there will be even more miraculous peace-time tasks for tubes to perform. Expansion in the use of electronic devices will bring many new calls for service work. With quality tubes, fine test equipment and new merchandising plans, National Union will be prepared, as never before, to help steer this profitable business your way.

NATIONAL UNION RADIO CORPORATION • NEWARK, NEW JERSEY • LANSDALE, PENNSYLVANIA

## NATIONAL UNION RADIO AND ELECTRONIC TUBES

Transmitting Tubes • Cathode Ray Tubes • Receiving Tubes • Special Purpose Tubes • Condensers •  
Volume Controls • Photo Electric Cells • Exciter Lamps • Panel Lamps • Flashlight Bulbs

# Audels -MANS RADIO GUIDE

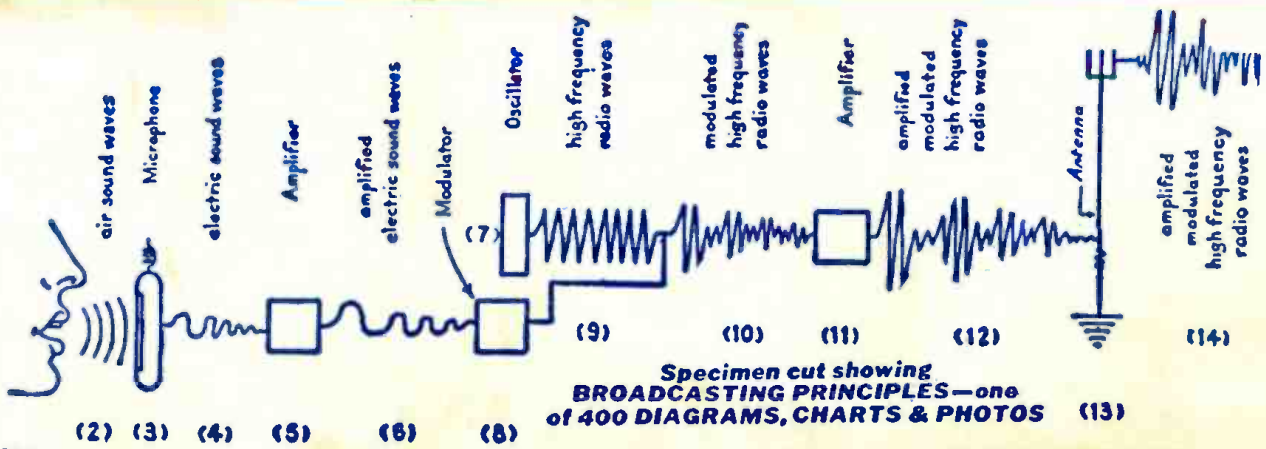

(1)  
**QUESTIONS  
AND  
ANSWERS**

**1001  
FACTS**



## THE KEY TO PRACTICAL RADIO INFORMATION

Including Frequency Modulation—Television, etc.

Inside Information for Aviation, Marine, Commercial Operators  
and Technicians, Servicemen and Students

**772 PAGES, 400 DIAGRAMS, CHARTS & PHOTOS**

This well organized reading course in Radio is especially suitable for home study and as a ready reference guide to help you learn the inside facts about radio. The amount of mathematics required for a successful study of this book is fully covered as the various chapters include numerous practical radio problems, carefully worked out, step by step, to their final solution. The contents are PROGRESSIVELY ARRANGED AND CAREFULLY INDEXED.

### LATE DATA—EASY TO READ AND UNDERSTAND

Gives Authentic Principles and Practices in Construction, Operation, Service & Repairs. Covers clearly and concisely Radio fundamentals—Ohm's Law—Physics of sound as related to radio science—Measuring instruments—Power supply—Resistors—Inductors—Condensers—Transformers and examples—Broadcasting stations—Radio Telephony—Receivers—Diagrams—Construction—Control systems—Loudspeakers—Antennas—Auto Radio—Phonograph pickups—Public Address Systems—Aircraft & Marine Radio—Radio Compass—Beacons—Automatic Radio Alarms—Short Wave—Coil Calculations—Testing—Cathode ray oscillographs—Static Elimination—Trouble Pointers—Underwriter's standards—Units & tables. REVIEW QUESTIONS—Ready Reference Index.

**HIGHLY ENDORSED—ASK TO SEE IT ON 7 DAYS' FREE TRIAL**

MAIL COUPON TODAY

**THEO. AUDEL & CO., Publishers, 49 West 23rd St., New York**  
Mail AUDELS NEW RADIOMAN'S GUIDE for free examination. If O.K. I will send you \$1 in 7 days, then remit \$1 monthly until \$4 is paid. Otherwise I will return it.

Name.....  
Address.....  
Occupation.....  
Reference.....

**\$4 COMPLETE  
PAY \$1 A  
ONLY 1 MO.**