

Most - Often - Needed

1947

RADIO
DIAGRAMS

and Servicing Information

Compiled by

M. N. BEITMAN

SUPREME PUBLICATIONS

CHICAGO

MANUAL OF 1947 MOST-OFTEN-NEEDED RADIO DIAGRAMS

INDEX

Admiral Radio		Clarion		Galvin Mfg. Co.	
3A1-AN	6	see Warwick Mfg.		HS-1	103
5A1	7-8			CR6	98-99
5B1A	6	Crosley Corp.		WR6	100
7B1	9-10	56FC	26	HS-7	102
10A1	11-13	56PA, 56PB	27-28	WR7	100
		56TG	29	WR8	100
Air King		56TG-M	30	HS-30	101
4604-A	14	56TG-O	29	HS-31	104
4608	15	56TH	29	HS-32	106-108
4625	16	56TH-M	30	HS-50	103
		56TH-O	29	55F11	101
Airline		56TJ	29	55X11,-A	103
see Montgomery		56TJ-M	30	55X12,-A	103
		56TJ-O	29	55X13,-A	103
Ansley Radio Corp.		56TP	31	65F11	104-105
41A	17	56TX-L	32	65F12	104-105
		106CP	33-34	65L11	102
Arvin				65L12	102
RE-204	111	Delco Radio		65T21,-B	106-108
RE-206-1	112	R-1230	162	HS-67	106-108
558	111	R-1231	162	705	109-110
664,-A	112	R-1232	162		
		R-1234	163		
Belmont Radio		R-1235	163		
5D110	19			Garod Radio	
5P19	18			6BU-1A	43
6D120	21			6DPS	44-45
				45APA	43
Bendix Radio					
526A,B,C,D,E	23	Emerson Radio		General Electric	
626-A	23	528	35	50	46
636A,C,D	20	120038	35	YRB 60-1	47
676B,C,D	22			YRB 60-2	47
736-B	24-25			106	49
				110	48
				111	48
Buick				200	50
980690	166	Fada Radio		203	50
980733	166	602	36	205	50
		637	36	219	51-52
		1001	37-38	220	51-52
				221	51-52
Cadillac				250	53
7253207	170	Farnsworth		303	54
		C-105	39-40		
Capitol Phonograph		ET-060	39-40		
U-24	114	ET-061	39-40		
C-1461	114	ET-063	39-40		
Chancellor		Federal Telephone			
6W	125	1030T	41-42	General Television	
		1540T	41-42	21A4	55
				22A5C	55
Chevrolet					
985793	169	Ford		W. T. Grant Co.	
		6MF080	185	500	56
				501	56

MANUAL OF 1947 MOST-OFTEN-NEEDED RADIO DIAGRAMS

Hamilton Radio

6-601W,V	57
6-602	57
6-604W,V	59
6-606	58

Hoffman Radio Corp.

107	60
108S	61
A500	60
A501	61

Howard Radio

901-A	62
901-AP	62
906	63
920	64

Hudson

6MH081	187
--------	-----

International Det.

558	65-66
-----	-------

Lear, Inc.

565, 565BL	67
566	67
567	67
568	67
661	68-69
6614	70
6615	70
6616	70
6619	70

McMurdo Silver Co.

VOMAX	76
-------	----

Majestic Radio

7C432	75
7C447	75
8S452	71-72
8S473	71-72
G1-426,-Y	73-74
4706	75
4707	75
4708	75
4807	73-74
4808	73-74
4810	71-72

Midwest Radio

P-6	77
PB-6	77
Series 8	78-79
S-8	78-79
ST-8	78-79
STM-8	78-79
TM-8	78-79
Series 12	80
78	78-79
712	80

Montgomery Ward

54WG-2700A	81-82
64BR-916A	83
64BR-917B	83
64BR-1205A	84
64BR-1206A	84
64BR-1208A	85
64BR-1513A	86
64BR-1514A	86
64BR-2200A	85
64BR-2701A	87-88
64BR-7100A	89
64BR-7110A	89
64BR-7120A	89
64WG-1050C	90
64WG-1052A	91
64WG-1207B	93
64WG-1511A	92
64WG-1512A	92
64WG-1801C	95
64WG-1807A	94
64WG-1809A	92
64WG-2009B	96
64WG-2500B	97
64WG-2700A	81-82
64WG-2700B	81-82

Motorola

HS-1	103
CR6	98-99
WR6	100
HS-7	102
WR7	100
WR8	100
HS-30	101
HS-31	104-105
HS-32	106-108
HS-50	103

Motorola (cont.)

55F11	101
55X11,-A	103
55X12,-A	103
55X13,-A	103
65F11	104-105
65F12	104-105
65L11	102
65L12	102
65T21,-B	106-108
HS-67	106-108
705	109-110

Noblitt-Sparks

RE-204	111
RE-206-1	112
558	111
664,-A	112

Oldsmobile

982375	165
982376	164

Olympic Radio

6-601W,V	57
6-602	57
6-604W,V	59
6-606	58

Packard-Bell

U-24	114
563	114
662	113
C-1461	114

Philco Radio

46-200	116
46-201	116
46-202	116
46-203	116
46-1201	115

Pontiac

984171	168
984172	167

R.C.A. Mfg. Co.

CV45	117
64F1	117
64F2	117

MANUAL OF 1947 MOST-OFTEN-NEEDED RADIO DIAGRAMS

R.C.A. (cont.)

64F3	117
65AU	118
65U	118
65X1	126
65X2	126
66-1	119
66BX	120
66E	122
66X1	121
66X2	121
66X3	121
66X4	121
66X9	121
67AV1	123-124
67V1	123-124
RS-126	122
RC-606	123-124
R.R. 1001	117
RC-1004E	119
RC-1017A	118
RC-1034	126
RC-1037	117
RC-1038	121
RC-1040	120

Radionic Equip. Co.

6W 125

Scott Radio

800-B 127-128

Sears, Roebuck

6011	133
6012	133
605Q	129
6071	129
7054	130
7080	130
7090	130
7100	130
7115	131-132
7116	131-132
7117	131-132
101.808	130
101.810	130
101.811	130
101.825	131-132
132.816	133
132.825-4	129
132.826-1	129

Sentinel Radio

292K	139-140
N292K	139-140

Sonora Radio

78	141
212	134
215	137
218	136
219	136
220	136
222	138 & 142
224	141
230	134
238	141
RBM/RBMU	135
RBU	135
RGMF/RGMFU	134
RKR/RKRU	137
RMR	136
RQ/RQU	138
RWF/RWFU	141
RYM/RYMU	141
RZ/RZU	142

Sparton

7-46,-PA	143-144
526,-PS,-X	145
846,-PA	143-144

Stewart-Warner

51T46	146
51T56	146
51T126	147
51T136	147
51T146	147
51T176	147
61TR36	148
61TR46	148
62T36	149
9001-C,D,E,F	150
9013-A	152-153

Stromberg-Carlson

1101	154-155
1110	156-157
1121	158-161

Truetone

see Western Auto

United Motors

R-1230	162
R-1231	162
R-1232	162
R-1234	163
R-1235	163
980690	166
980733	166

United Motors

982375	165
982376	164
984171	168
984172	167
985793	169
7253207	170

Warwick Mfg. Co.

C102, C103 171

Western Auto

2AW2	180
4B114	176
5P110	179
6D117	175
23P1-634	180
25BD2-606	177
26A76-650	173
26C19-61	178
D-1644	172
D-1645	173
D-2605,2607	180
D-2616	175
D-2622	174
D-2665	176
D-3615	177
D-3619	179
D-4630	178

Westinghouse Elec.

H-104	181-182
H-105	181-182
H-107	181-182
H-108	181-182
H-110,H-111	182
H-137,H-138	182

Wilcox-Gay Corp.

6A10,6A20	184
6B10,6B20	183-184
6B30,6B32	183-184

Zenith Radio Corp.

5C50	186
5K037	186
6C01	188-189
6D014	188-189
6D029	188-189
6MF080	185
6MH081	187
8C01	190-192
8H023	190-192
8H034	190-192

MANUAL OF 1947 MOST-OFTEN-NEEDED RADIO DIAGRAMS

ADMIRAL CORPORATION. Information on MODEL 5B1A Phono Chassis.

The Model 5B1A is similar to Model 5B1 listed on pages 10 & 11 in Vol. 6, 1946 Manual. The main differences are:

A new rotary phono-radio switch is used to positively eliminate cross talk. This is accomplished by opening the B+ feed to the front end of the set when the switch is in the photograph position. *** A 10 megohm resistor R14 has been added to the circuit to prevent occasional momentary blocking of the 12SK7 tube employed in the I.F. stage.

Admiral Corporation Model 3A1-AN

See page 7 of Vol. 6
1946 Manual for the
similar model 3A1.

VOLTAGE DATA

Voltage measured from socket terminal to point marked "X". Large numerals indicate readings with vacuum tube voltmeter. Small numerals indicate readings with 1000 ohm-per-volt meter.

* * *

POWER SUPPLY

Operation on 105-125 volts, 60-cycle, alternating current only. Power consumption: 45 watts.

RECORD CHANGER

Complete service information and parts list are covered by a separate service manual. Check record changer for model number since different record changers may be used from time to time.

VOLTAGE CHART

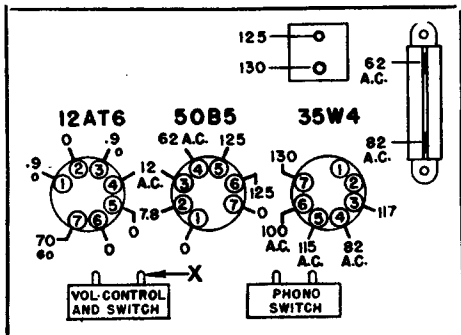

RESISTORS			CONDENSERS		
SYMBOL	OHMS	WATTS	SYMBOL	CAPACITY	VOLTS
R1	1,000,000	V. C.	C1	.005 Mfd.	600
R2	10,000,000	½	C2	.01 Mfd.	400
R3	270,000	½	C3	.02 Mfd.	400
R4	470,000	½	C4a	50. Mfd.	150
R5	150	1	C4b	30. Mfd.	150
R6	1,500	1	C5	.1 Mfd.	400
R7	130	5	C6	.1 Mfd.	400
R8	33	1	C7	.05 Mfd.	400

TUBES USED

12AT6—Driver (audio) 50B5—Power Output 35W4—Rectifier

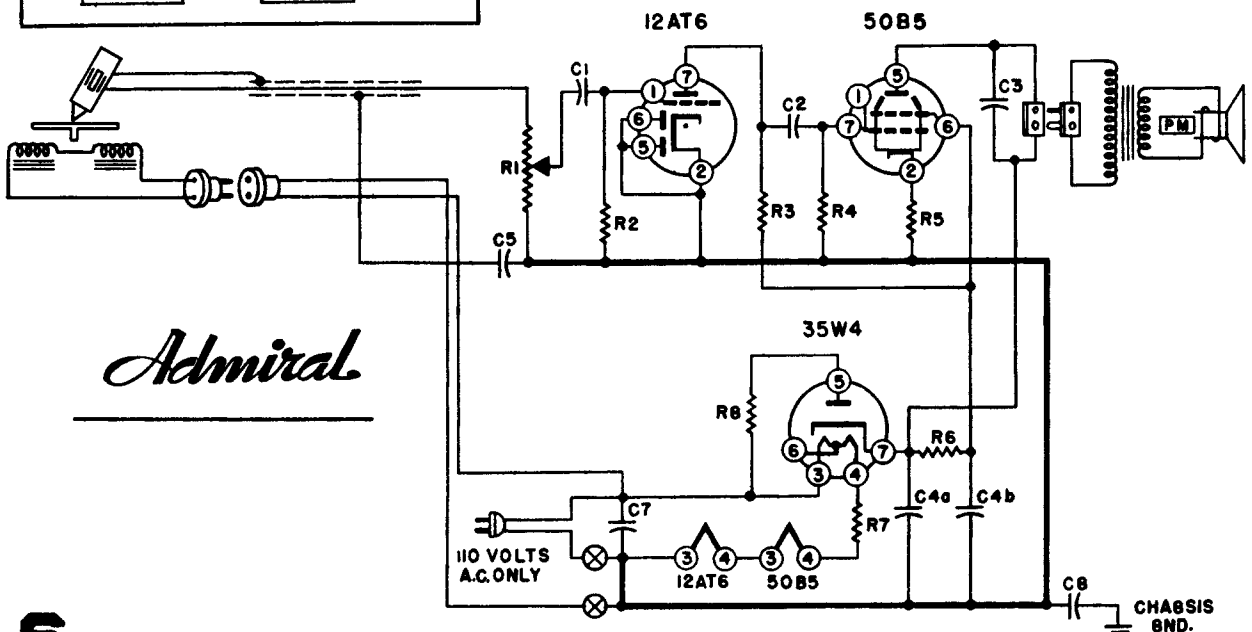

Admiral

MANUAL OF 1947 MOST-OFTEN-NEEDED RADIO DIAGRAMS

Admiral

CHASSIS-5A1

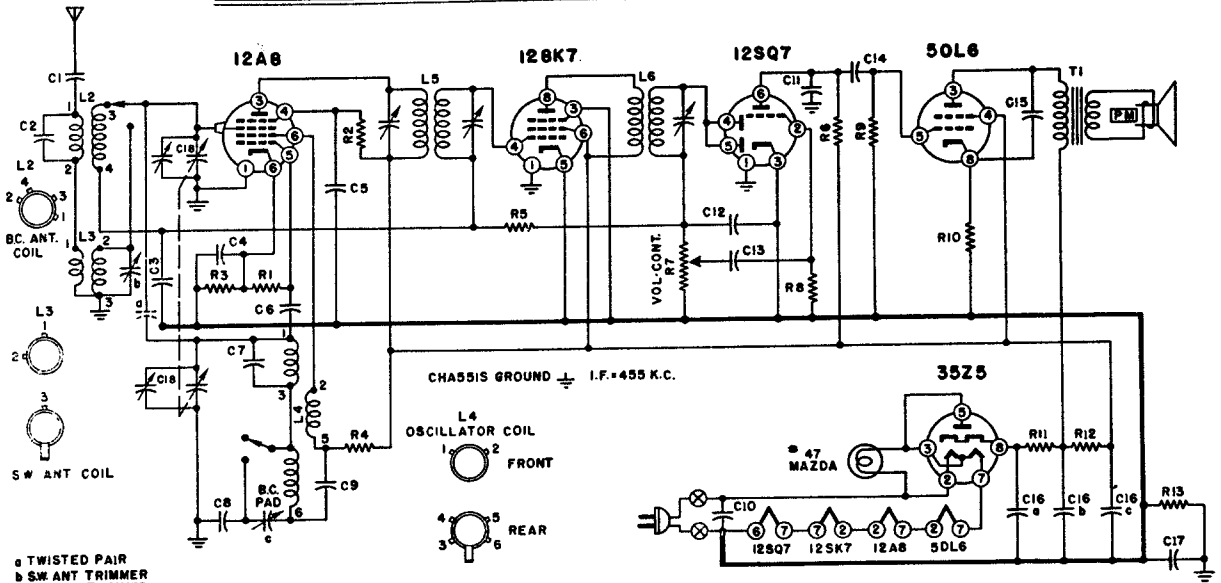

a TWISTED PAIR
b SW ANT TRIMMER
c BC CSC-TRIMMER

VOLTAGE CHART

VOLTAGE DATA

BOTTOM VIEW

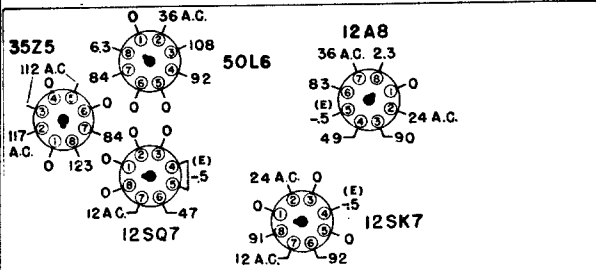

REAR OF CHASSIS

1. All readings made between Tube Socket Terminals and Terminal No. 8 on the 12SQ7 Socket.
2. Measured on a 117 Volt A.C. line.
3. Volume control full on.
4. Dial tuned to low frequency end, no signal.
5. Voltages indicated (E) obtained on Vacuum Tube volt meter.
6. All other readings shown are made with a 1000 ohm per volt meter.

REPLACEMENT PARTS

CONDENSERS

Symbol	Description	Part No.
C1	.001 Mfd., paper, 400 V.	65A2-5
C2	.00005 Mfd., mica, 500 V.	65B5-ii
C3	.05 Mfd., paper, 400 V.	65A2-4
C4	.05 Mfd., paper, 400 V.	65A2-4
C5	.05 Mfd., paper, 400 V.	65A2-4
C6	.0001 Mfd., mica, 500 V.	65B5-17
C7	.00001 Mfd., mica, 500 V.	65B5-1
C8	.003 Mfd., mica, 500 V.	65B1-6
C9	.005 Mfd., paper, 400 V.	65A2-2
C10	.05 Mfd., paper, 400 V.	65A2-4
C11	.0005 Mfd., mica, 500 V.	65B5-27
C12	.00025 Mfd., mica, 500 V.	65B5-22
C13	.01 Mfd., paper, 400 V.	65A2-3
C14	.002 Mfd., paper, 400 V.	65A2-1
C15	.01 Mfd., paper, 400 V.	65A2-3
C16a	30 Mfd., electrolytic, 150 V.	67C7-41
C16b	30 Mfd., electrolytic, 150 V.	
C16c	20 Mfd., electrolytic, 150 V.	
C17	.2 Mfd., paper, 400 V.	65A2-10
b, c	Trimmer Condenser	66A1-i
C18	Tuning Condenser Gang	68A1

RESISTORS

Symbol	Description	Part No.
R1	47,000 Ohms, Carbon, 1/2 W.	60B8-473
R2	22,000 Ohms, Carbon, 1/2 W.	60B8-223
R3	470 Ohms, Carbon, 1/2 W.	60B8-471
R4	3,300 Ohms, Carbon, 1/2 W.	60B8-332
R5	2.2 Meg Ohms, Carbon, 1/2 W.	60B8-225
R6	220,000 Ohms, Carbon, 1/2 W.	60B8-224
R7	.5 Meg. Ohms, Volume Control	75B1-7
R8	4.7 Meg Ohms, Carbon 1/2 W.	60B8-475
R9	470,000 Ohms, Carbon, 1/2 W.	60B8-474
R10	220 Ohms, Carbon, 1/2 W.	60B8-221
R11	150 Ohms, Carbon, 1 W.	60B28-1
R12	1,000 Ohms, Carbon, 1 W.	60B28-2
R13	150,000 Ohms, Carbon, 1/2 W.	60B28-154

COILS & TRANSFORMERS

Symbol	Description	Part No.
L2	BC, Antenna coil	69A1
L3	SW, Antenna coil	69A2
L4	BC & SW, Oscillator coil	69A3
L5	1st I.F. Trans.	72B2
L6	2nd I.F. Trans.	72B1

MISCELLANEOUS

Description	Part No.
Band Change Switch	77B1-4
Buttons, Snap for Dial Background	13A1-3-2
Cabinet, Ivory Plastic	34D1-1
Cabinet, Mahogany Plastic	34D1-2
Collar for Line Cord Connector	32A19
Connector for Line Cord (female plug)	88A6-2
Cord, Line, 220 V.	89A3
Dial Background	22B7-i
Dial Cord (42 inches)	50A1-i
Dial Pointer Strip	25A3
Dial Pointer Slide	25A2
Drive Drum Assembly	A1012
Fibre Dial Pulley	17A1-3
Knob, Ivory	33A1-i
Knob, Mahogany or Walnut	33A1-2
Pilot light, Mazda No. 47	81A1-8
Pilot light Socket & leads	82A2-2
Shaft, Tuning	28A1-i

MANUAL OF 1947 MOST-OFTEN-NEEDED RADIO DIAGRAMS

5A1—CHASSIS

Admiral

ALIGNMENT PROCEDURE

1. Be sure both set and signal generator are thoroughly warmed up before starting alignment.
2. Turn gang condenser to wide open position and make sure that dial pointer is at position marked "pointer extremes" on the dial diagram (see below).
3. Connect Output Meter across the Voice Coil.
4. Turn receiver Volume Control full on.
5. Use *lowest* output setting of signal generator that will give a satisfactory reading on the Output Meter.
6. Proceed in sequence as indicated in the chart.

Dummy Antenna in Series with Signal Generator	Signal Generator Frequency	Connect Signal Generator to	Band Switch Position	Receiver Dial Pointer Setting	Adjust Following Trimmers	Type of Adjustment
.00025 Mica	455 K.C.	Grid Cap 12A8 Tube	B.C.	Gang-Condenser Wide open	(A) 2nd I.F. (B) 1st I.F. (C) 1st I.F.	Maximum Deflection Output Meter
.00025 Mica	1730 K.C.	End of Ant. Wire	B.C.	Set to Black dot at extreme upper end of scale.	(D) B.C. Osc.	Maximum Deflection Output Meter
.00025 Mica	1400 K.C.	End of Ant. Wire	B.C.	Tune in Generator Signal	(E) B.C. Ant.	Maximum Deflection Output Meter
.00025 Mica	600 K.C.	End of Ant. Wire	B.C.	Tune in Generator Signal	(F) B.C. Pad Rock Condenser gang while adjusting.	Maximum Deflection Output Meter
Recheck Alignment at 1400 Kc (2nd step above)						
400 ohm Carbon	15 Mc.	End of Ant. Wire	S.W.	Tune in Generator Signal	(G) S.W. Antenna	Maximum Deflection Output Meter

TUBE and TRIMMER LAYOUT

Top View

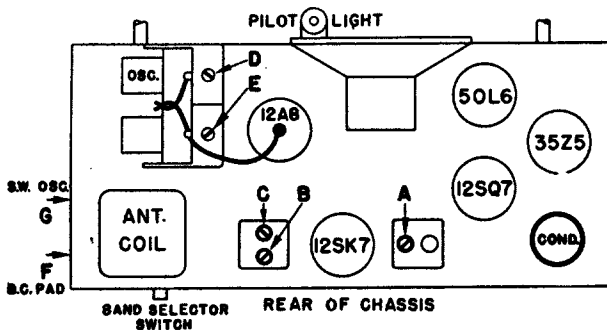

DIAL STRINGING

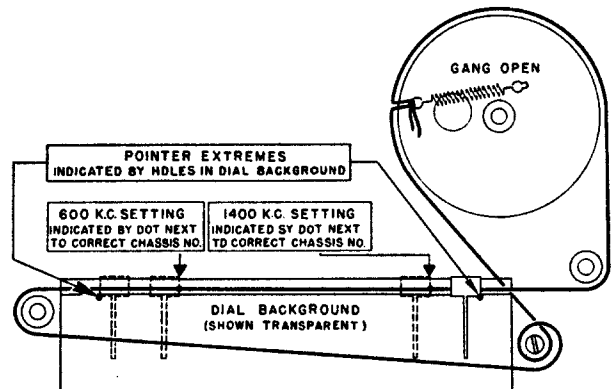

Chassis 5A1—A.C.-D.C. 5 tube Superheterodyne covering two bands, (540 K.C.—1730 K.C.) and 5.45 Megacycles—17.5 Megacycles.

MANUAL OF 1947 MOST-OFTEN-NEEDED RADIO DIAGRAMS

Admiral

CHASSIS 7B1

REPLACEMENT PARTS

RESISTORS			CONDENSERS (Cont'd)			MISCELLANEOUS	
Symbol	Description	Part No.	Symbol	Description	Part No.	Description	Part No.
R1	12,000 Ohms 5 Watt	61A1-1	C18	.01 Mfd., 400 Volts, Condenser	64B1-25	Background, Dial.....	22B7-1
R2	150,000 Ohms 1/2 Watt	60B8-154	C19	.01 Mfd., 600 Volts, Condenser	64B1-10	Bulb, Pilot Light No. 47.....	81A1-8
R3	470,000 Ohms 1/2 Watt	60B8-474	C20a	30 Mfd., 350 Volts	67C6-25	Button (For Phono switch button).....	33A8-1
R4	10,000 Ohms 2 Watt	60B8-103	C20b	30 Mfd., 350 Volts		Cable and Plug, Shielded.....	89A5-1
R6	22,000 Ohms 1/2 Watt	60B8-223	C20c	20 Mfd., 25 Volts	Cord, Dial (64" approx.).....	50A1-3	
R7	10 Megohms 1/2 Watt	60B8-106	C21a	3-40 Mmfd. Trimmer	Drum, Dial.....	17A3	
R8	1 Megohm 1/2 Watt	60B8-105	C21b	3-40 Mmfd. Trimmer	Escutcheon, Dial.....	21C7-1	
R9	2 Megohms, Tone Control	75B1-5	C22a	3-40 Mmfd. Trimmer	Escutcheon, Switch.....	26A7-1	
R10	27,000 Ohms 1/2 Watt	60B8-273	C22b	3-40 Mmfd. Trimmer	Knob, Tuning.....	33B9-1	
R11	1 Megohm, Volume Control Tapped at Approx. 500,000 ohms	75B2-1	C23a	3-40 Mmfd. Trimmer	Knob, SW, B.C., Phono.....	33B9-2	
R12	270,000 Ohms 1/2 Watt	60B8-274	C23b	3-40 Mmfd. Trimmer	Knob, Tone.....	33B9-3	
R13	470,000 Ohms 1/2 Watt	60B8-474	C24	100 Mmfd., Mica	Knob, Volume.....	33B9-4	
R14	470,000 Ohms 1/2 Watt	60B8-474	C26	1,200 Mmfd., Mica	Pin Tip, Antenna (Large).....	86A2-1	
R15	1 Megohm 1/2 Watt	60B8-105	C27	100 Mmfd., Mica	Pin Tip, Antenna (Small).....	86A2-2	
R16	390 Ohms 1 Watt	60B8-391	TRANSFORMERS and COILS			Plug, Speaker.....	88A4-4
R17	10 Megohms 1/2 Watt	60B8-106	Symbol	Description	Part No.	Plug, Phono Output.....	88A2-1
R18	100 Ohms 1/2 Watt	60B8-101	L1	Antenna, Loop	AC104	Pointer, Dial.....	25A3
R19	47,000 Ohms 1/2 Watt	60B8-473	L2	Coil, S.W. Antenna	AD116-1	Slug, B.C. Tuning—Specify color code when ordering.....	71B1-3
R20	100,000 Ohms 1/2 Watt	60B8-104	L3	Coil, B.C. Antenna	AB100-2	Slug, S.W. Tuning—Specify color code when ordering.....	71B1-9
R22	100 Ohms 1/2 Watt	60B8-101	L4	Coil, B.C. R.F.	AB100-1	Socket, Dial Light.....	82A2-1
CONDENSERS			L5	Coil, S.W. R.F.	AD116-2	Socket, Speaker.....	87A6-1
Symbol	Description	Part No.	L6	Coil, S.W. Oscillator	AD116-3	Speaker.....	78B7
C1	1,000 Mmfd., Mica	65B7-33	L7	Coil, B.C. Oscillator	AC101-1	Spring, Drum Tanston.....	19B1-7
C2	140 Mmfd., Silver Mica 3%	65B1-26	T1	Transformer, 1st I.F.	72B7	Stud, Slug adjusting.....	27A4
C3	25 Mmfd., Silver Mica 3%	65B1-28	T2	Transformer, 2nd I.F.	72B8	PHONOGRAPH PARTS	
C4	100 Mmfd., Mica	65B7-17	T3	Transformer, Power	80B1	See Record Changer Service Manual for Detailed Parts List.	
C5	50 Mmfd., Mica	65B5-11	T4	Transformer, Output	98B6-1	Description	Part No.
C6	.05 Mfd., 400 Volts	64B1-22	CH1	Choke, Filter	74A3	Centerpost.....	G400A12
C7	65 Mmfd., Silver Mica 3%	65B1-27	CH2	Choke, Oscillator Cathode	AB103-1	Crystal Cartridge.....	409A1
C8	420 Mmfd., Silver Mica 2%	65B1-13	SWITCHES, PLUGS and SOCKETS			Idler Wheel (407B3 Motor).....	G400A23
C10	20 Mmfd., Mica	65B7-5	Symbol	Description	Part No.	Idler Wheel (407B2 Motor).....	G400A59
C11	65 Mmfd., Silver Mica 3%	65B1-27	S1	Socket, Phono	B8A1	Idler Wheel (407B1 Motor).....	G400A57
C12	200 Mmfd., Silver Mica 2%	65B1-14	S2	Socket, Speaker	87A6-1	Motor, 60 cycle 115 volt, A.C. (Types 407B1 & 407B2 also used)....	407B3
C13	.1 Mfd., 400 Volts	64B1-20	S3	Socket and Cord, Phono Motor	89A6-3		
C14	250 Mmfd., Mica	65B7-22	SW1	Switch, Antenna	76B1-3		
C15	1,000 Mmfd., Mica	65B7-33	SW2	Switch, Oscillator	76B1-2		
C16	.02 Mfd., 400 Volts	64B1-24	SW3	Switch, R.F.	76B1-1		
C17	.01 Mfd., 400 Volts, Condenser	64B1-25	SW4	Switch (on-off) S.P.S.T.	77B1-44		

POINTER ADJUSTMENT

Move the dial pointer by means of the tuning control knob to see that it reaches the upper and lower limits as shown on the stringing diagram. In the upper limit position measure the distance D-E and in the lower limit position measure the distance A-B. The distance from A and B must be the same as the distance from D to E. If these distances are not equal, unclamp and move the pointer slide on the string until they are the same. The pointer should be checked again at the upper and lower limit to be sure that it is right. Take care to see that the pointer does not slip during this operation. Reclamp the pointer slide tightly to the string and seal with any quick-drying cement. Set the tuning gang wide open and proceed with operation 3.

REPLACING TUNING SLUG

If it becomes necessary to change a tuning slug proceed in the following manner: Set the gang to its wide open position, unsolder and remove the old slug. Set the slug adjusting screw about half way down. Place the new slug in such a position that 1 1/8 inches of its length is above the coil form. Solder it in this position making sure that it does not slip during the operation and that the slug wire is straight. Proceed to realign the set as shown in the chart.

STRINGING DIAGRAM

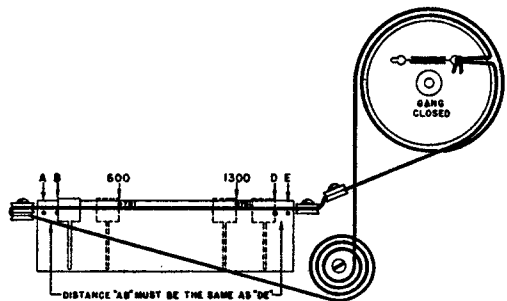

VOLTAGE CHART

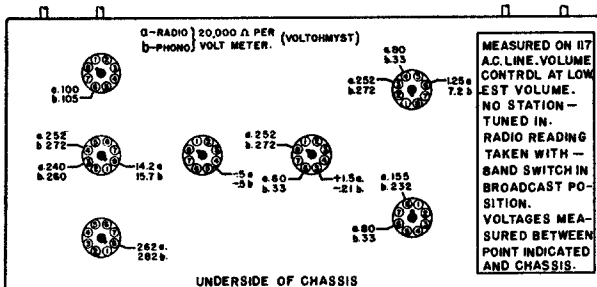

MANUAL OF 1947 MOST-OFTEN-NEEDED RADIO DIAGRAMS

ALIGNMENT PROCEDURE

1. Loop must be connected during alignment.
Check the set screws that hold the tuning drum to the shaft to see that they are tight and that the drum has not slipped on the shaft. The correct position of the drum can be seen on the stringing diagram.
2. In the closed position the stop on the rear of the dial drum must be against the stop post.
3. With the gang wide open, all slugs should be $1\frac{1}{8}$ inches out of their coil forms. If there is any serious deviation or if there has been any tampering, turn the adjusting screws until this distance is correct.
4. Be sure both the set and the signal generator are thoroughly warmed up before starting alignment.
5. Turn receiver Volume Control full on.
6. Use lowest output setting of signal generator that gives a satisfactory reading on meter.
7. Proceed in sequence as outlined below.

STEP	CONNECT SIGNAL GENERATOR TO	DUMMY ANTENNA BETWEEN RADIO AND SIGNAL GENERATOR	SIGNAL GENERATOR FREQUENCY	TUNING GANG SETTING	ADJ. TRIMMERS IN FOLLOWING ORDER TO MAX.
1	Set Band Change Switch to Broadcast Position. 6SA7 Grid (Pin #8)	.1 MFD.	455 K.C.	Set Pointer to Upper Limit	A, B, C, D
2	Before proceeding to step 3 check pointer travel as outlined under paragraph below headed "Pointer Adjustment."				
3	Black Loop Lead	20 MMFD. If not available wrap several turns of the generator lead around the black loop lead.	1605 K.C.	Set Pointer to Upper Limit	E, F, G
4	Black Loop Lead		1300 K.C.	Set Pointer to 1300 Mark on Slide Rail	H, I, J
5	Set Band Change Switch to Short Wave Position.				
6	Black Loop Lead	400 Ohms	12.5 M.C.	Set Pointer to Upper Limit	K, L, M
7	Black Loop Lead	400 Ohms	12.0 M.C.	Set Pointer to 1300 Mark on Slide Rail	N, O, P

Admiral

CHASSIS 7B1

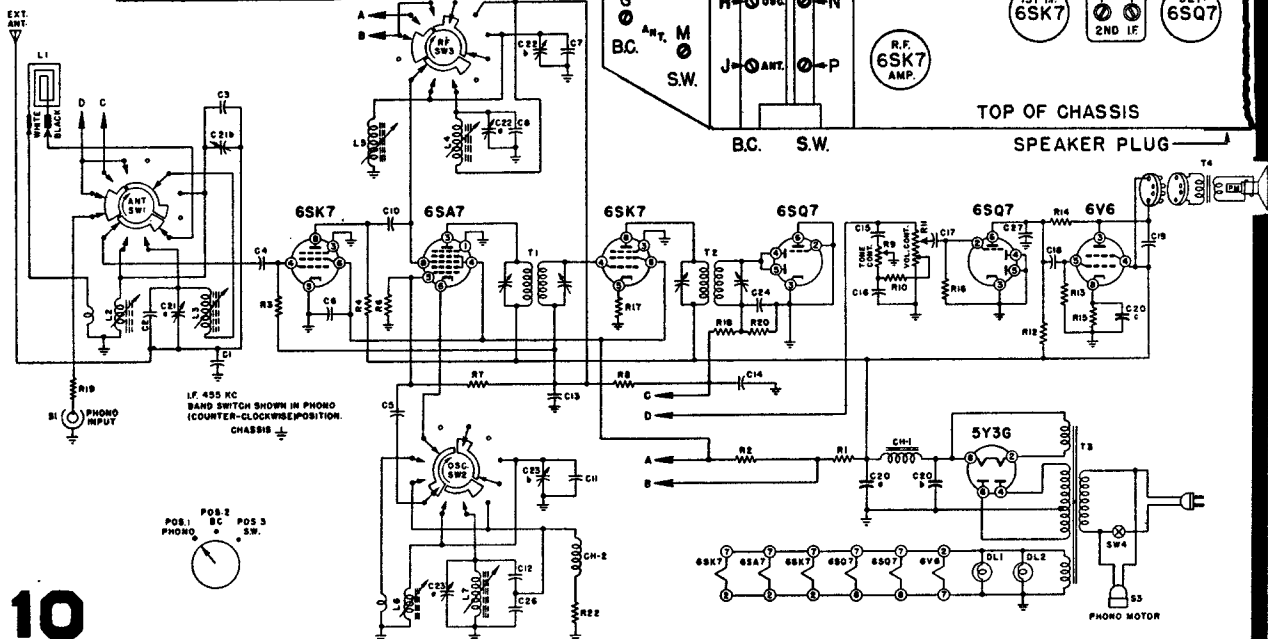

MANUAL OF 1947 MOST-OFTEN-NEEDED RADIO DIAGRAMS

Admiral ALIGNMENT PROCEDURE CHASSIS 10A1

- Loop must be connected during alignment.
Check the set screws that hold the tuning drum to the shaft to see that they are tight and that the drum has not slipped on the shaft. The correct position of the drum can be seen on stringing diagram (A).
- In the wide open position the stop on the rear of the dial drum must be against the stop post.
- With the gang wide open, all slugs should be 1 3/8 inches out of their coil forms. If there is any serious deviation of if there has been any tampering, turn the adjusting screws until this distance is corrected. (See paragraph on Tuning Slug Replacement.)
- Be sure both the set and the signal generator are thoroughly warmed up before starting alignment.
- Turn receiver Volume Control full on.
- Use lowest output setting of signal generator that gives a satisfactory reading on meter.
- Proceed in sequence as outlined below.

STEP	CONNECT SIGNAL GENERATOR TO	DUMMY ANTENNA BETWEEN RADIO AND SIGNAL GENERATOR	SIGNAL GENERATOR FREQUENCY	TUNING GANG SETTING	ADJ. TRIMMERS IN FOLLOWING ORDER TO MAX.
1	6SA7 Grid (Pin #8)	.1 MFD.	455 K.C.	Pointer to upper limit	E, D, C, B, A
2	Before proceeding to step 3 check pointer travel as outlined under paragraph below headed "Pointer Adjustment." Set Band Change Switch to Broadcast Position.				
3	White Loop Lead	10 MMFD. If not available wrap several turns of the generator lead around the white loop lead.	1605 K.C.	Pointer to upper limit	F, G, H
4	White Loop Lead		1300 K.C.	Set Pointer to 1300 mark on slide rail (See Dial Diagram A)	I, J, K
5	Set Band Change Switch to 49 Meter Position.				
6	White Loop Lead	400 Ohms	7.5 Mc.	Pointer to upper limit	L, M
7	White Loop Lead	400 Ohms	7.2 Mc.	Set Pointer to 1300 mark on slide rail	N, O
8	Set Band Change Switch to 31-25 Meter Position.				
9	White Loop Lead	400 Ohms	12.5 Mc.	Pointer to upper limit	P, Q
10	Set Band Change Switch to 19-16 Meter Position.				
11	White Loop Lead	400 Ohms	18.0 Mc.	Pointer to upper limit	R, S

POINTER ADJUSTMENT

Move the dial pointer by means of the tuning control knob to see that it reaches the upper and lower limits as shown on stringing diagram (A). In the upper limit position measure the distance D-E and in the lower limit position measure the distance A-B. The distance from A and B must be the same as the distance from D to E. If these distances are not equal, unclamp and move the pointer slide on the string until they are the same. The pointer should be checked again at the upper and lower limit to be sure that it is right. Take care to see that the pointer does not slip during this operation. Reclamp the pointer slide tightly to the string and seal with any quick-drying cement. Set the tuning gang wide open and proceed with operation 3.

TUBE AND TRIMMER LAYOUTS

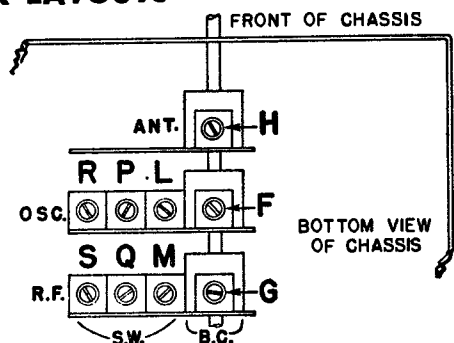
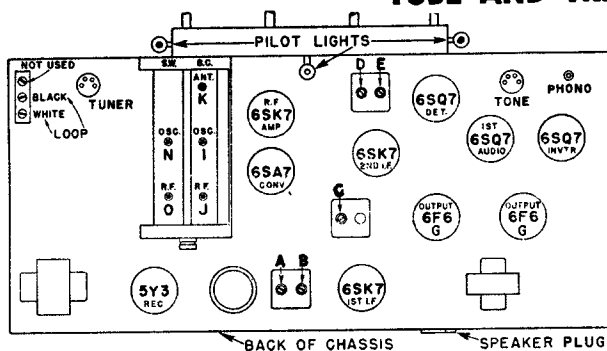

MANUAL OF 1947 MOST-OFTEN-NEEDED RADIO DIAGRAMS

REPLACING TUNING SLUG

If it becomes necessary to change a tuning slug proceed in the following manner: Set the gang to its wide open position, unsolder and remove the old slug. Set the slug adjusting screw about half way down. Place the new slug in such a position that 1 3/4 inches of its length is above the coil form. Solder it in this position making sure that it does not slip during the operation and that the slug wire is straight. Proceed to realign the set as shown in the chart.

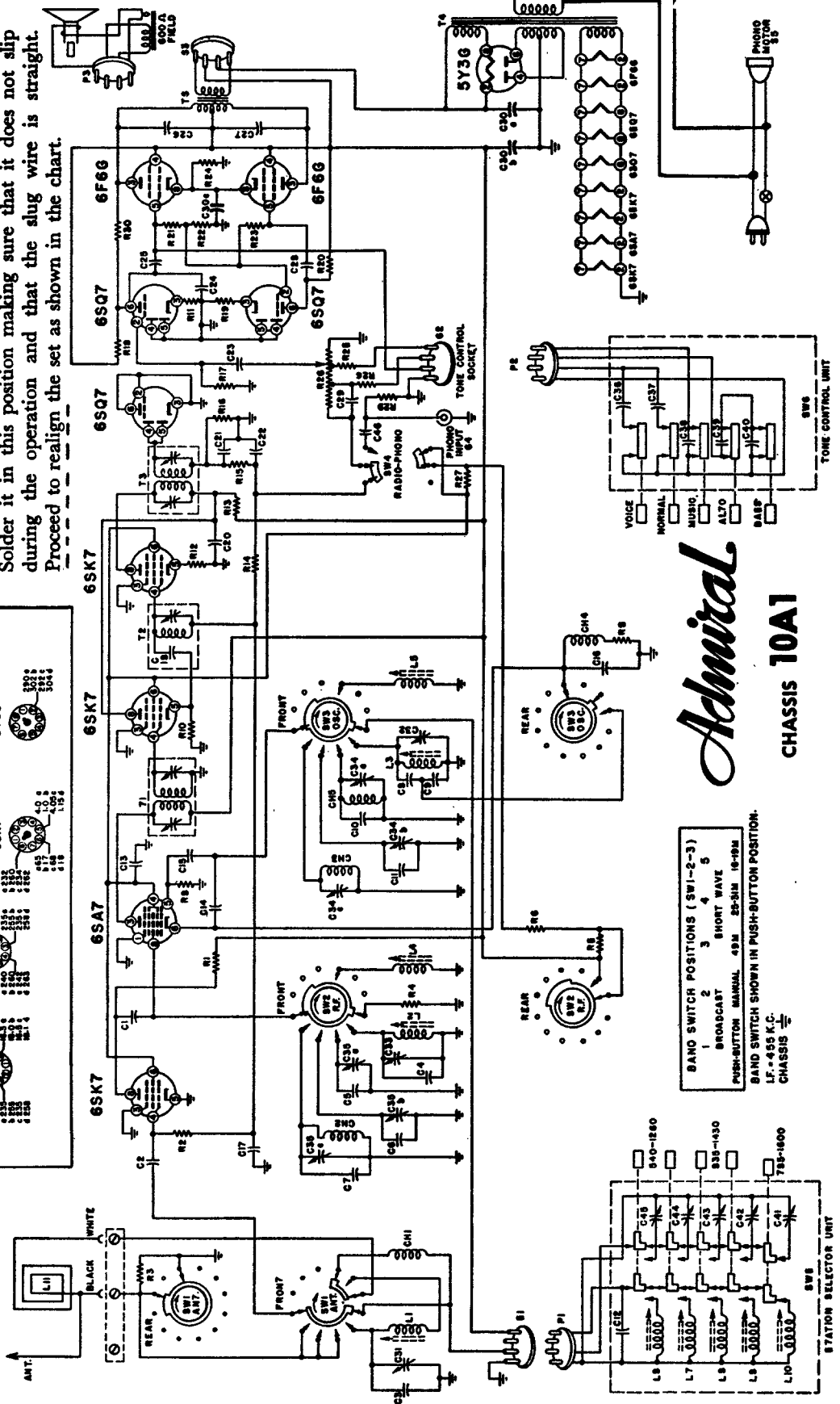
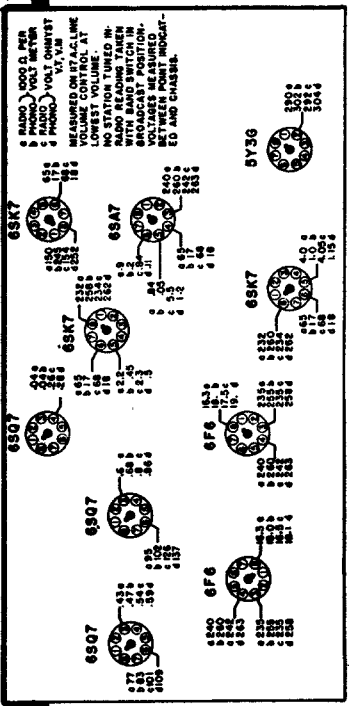

Admiral

CHASSIS 10A1

BAND SWITCH POSITIONS (SW1-2-3)
 1 BROADCAST
 2 SHORT WAVE
 3 BROADCAST
 4 MANUAL
 5 PUSH-BUTTON
 BAND SWITCH SHOWN IN PUSH-BUTTON POSITION.
 LF. - 455 K.C.
 CHASSIS

MANUAL OF 1947 MOST-OFTEN-NEEDED RADIO DIAGRAMS

Admiral

CHASSIS 10A1

CONDENSERS

RESISTORS

Symbol	Description	Part
C1	20 mmfd. Mica	65B7-3
C2	200 mmfd. Mica	65B7-21
C3	35 mmfd. Silver Mica	65B1-30
C4	390 mmfd. Silver Mica	65B1-34
C5	250 mmfd. Silver Mica	65B1-35
C6	65 mmfd. Silver Mica	65B1-27
C7	40 mmfd. Silver Mica	65B1-36
C8	140 mmfd. Silver Mica	65B1-26
C9	1000 mmfd. Mica	65B7-33
C10	200 mmfd. Silver Mica	65B1-14
C11	15 mmfd. Silver Mica	65B5-3
C12	60 mmfd. Silver Mica	65B5-13
C13	1 mfd. 400 Volts	64B1-20
C14	50 mmfd. Mica	65B5-11
C15	50 mmfd. Mica	65B5-11
C16	250 mmfd. Mica	65B5-22
C17	.05 mfd. 200 Volts	64B1-32
C18	20 mmfd. Mica	65B5-5
C20	1 mfd. 400 Volts	64B1-20
C21	50 mmfd. Mica	65B5-11
C22	50 mmfd. Mica	65B5-11
C23	.002 mfd. 600 Volts	64B1-14
C24	500 mmfd. Mica	65B5-27
C25	.005 mfd. 600 Volts	64B1-12
C26	.005 mfd. 600 Volts	64B1-12
C27	.005 mfd. 600 Volts	64B1-12
C28	.005 mfd. 600 Volts	64B1-12
C29	250 mmfd. Mica	65B5-22
C30a	30 mfd. 350 Volts	Electrolytic.....67C6-25
C30b	30 mfd. 350 Volts	
C30c	20 mfd. 25 Volts	
C31	3-40 mmfd.	66A12-5
C32	3-40 mmfd. Trimmer	
C33	3-40 mmfd.	
C34a	3-40 mmfd.	66B8-3
C34b	3-40 mmfd. Trimmer	
C34c	3-40 mmfd.	
C35a	3-40 mmfd.	66B8-3
C35b	3-40 mmfd. Trimmer	
C35c	3-40 mmfd.	

Symbol	Description	Part Number
R1	10,000 Ohms, 1 Watt	60B14-103
R2	470,000 Ohms, 1/2 Watt	60B8-474
R3	47,000 Ohms, 1/2 Watt	60B8-473
R4	470,000 Ohms, 1/2 Watt	60B8-474
R5	8,200 Ohms, 1 Watt	60B14-822
R6	10,000 Ohms, 1/2 Watt	61A1-3
R8	22,000 Ohms, 1/2 Watt	60B8-223
R9	100 Ohms, 1/2 Watt	60B8-101
R10	1,500 Ohms, 1/2 Watt	60B8-152
R11	1,500 Ohms, 1/2 Watt	60B8-152
R12	470 Ohms, 1/2 Watt	60B8-471
R13	1,000 Ohms, 1/2 Watt	60B8-102
R14	470,000 Ohms, 1/2 Watt	60B8-474
R15	47,000 Ohms, 1/2 Watt	60B8-473
R16	270,000 Ohms, 1/2 Watt	60B8-274
R17	1.0 Megohm, 1/2 Watt	60B8-105
R18	270,000 Ohms, 1/2 Watt	60B8-274
R19	1,000 Ohms, 1/2 Watt	60B8-102
R20	270,000 Ohms, 1/2 Watt	60B8-274
R21	470,000 Ohms, 1/2 Watt	60B8-474
R22	470,000 Ohms, 1/2 Watt	60B8-474
R23	470,000 Ohms, 1/2 Watt	60B8-474
R24	270 Ohms, 2 Watt	60B20-271
R25	47,000 Ohms, 1/2 Watt	60B8-473
R26	100,000 Ohms, 1/2 Watt	60B8-104
R27	150,000 Ohms, 1/2 Watt	60B8-154
R28	1 Megohm Volume Control	75B3-3
R29	1 Megohm, 1/2 Watt	60B8-105
R30	1 Megohm, 1/2 Watt	60B8-105

C36	.002 mfd., 600 Volts	64B1-14
C37	.001 mfd., 600 Volts	64B1-15
C38	.005 mfd., 600 Volts	64B1-12
C39	.01 mfd., 400 Volts	64B1-25
C40	.005 mfd., 600 Volts	64B1-12
C41	12-170 mmfd. Trimmer	66A12-1
C42	25-290 mmfd. Trimmer	66A12-2
C43		
C44	40-400 mmfd. Trimmer	66A12-3
C45		
C46		
C46	.002-600 volts	64B1-14

STRINGING DIAGRAMS

DIAGRAM (A)

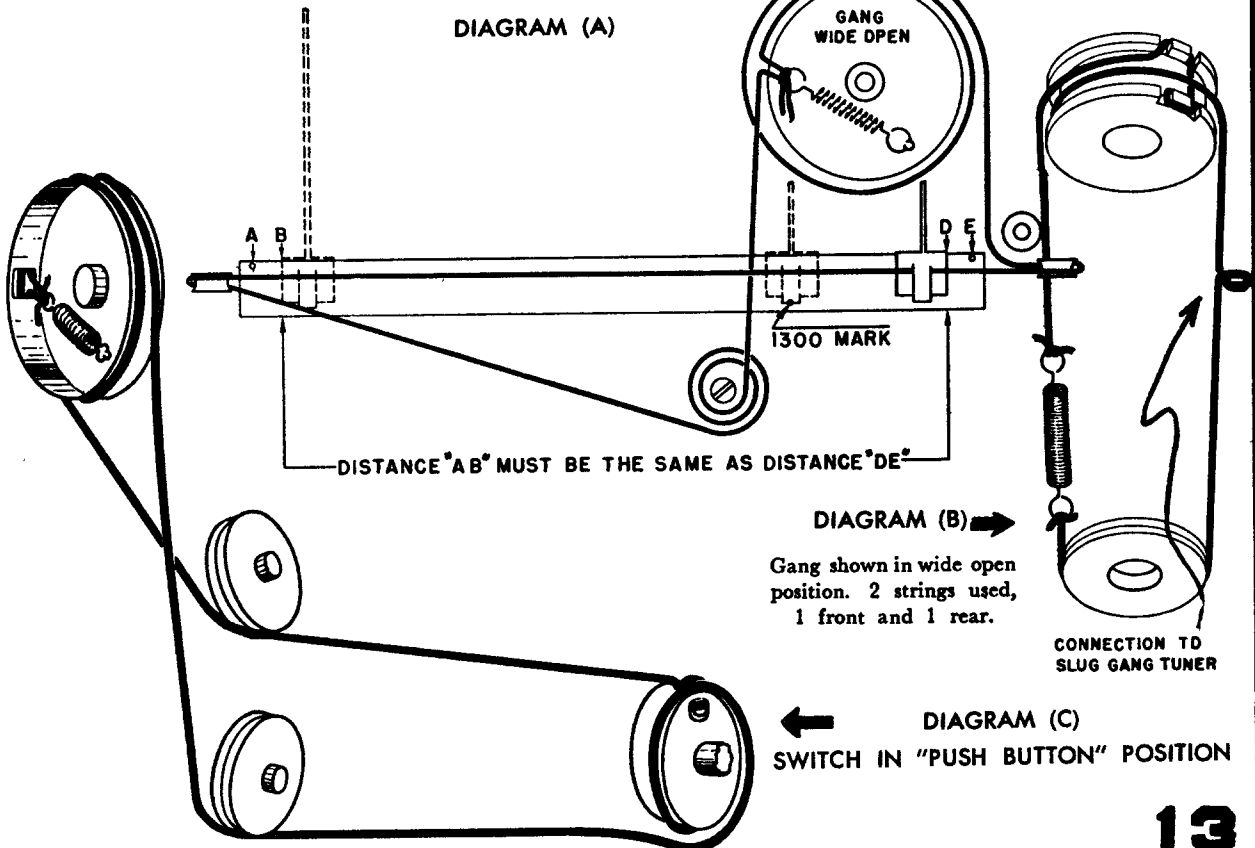

Radio Model 4604-A

Model 4604 is similar but uses tube type 7H7 instead of the first 6SK7, a 7B6 instead 6SQ7, and a 7A4 instead 6J5 oscillator.

PARTS LIST

Schematic Location	Part No.	Description
L1	457	Cabinet
L2	62172	Cover - back
L3	28135	Coil, loop - Ant.
L4	28137	Coil, SW osc with trimmer
L5	28138	Coil, BC osc with padder
C1, C4, C6, C16	28136	Condenser, .05 mfd, 400 volts
C5		Condenser, .1 mfd, 400 volts
C9		Condenser, .002 mfd, 400 volts
C10		Condenser, .005 mfd, 400 volts
C11		Condenser, .01 mfd, 400 volts
C12		Condenser, .01 mfd, 400 volts
C18, C17		Condenser, .02 mfd, 400 volts
C13, C8, C7		Condenser, Mica, .0001 mfd, 400 volts
C2		Condenser, Mica, .00025 - 400 volts
C13, C14, C15	1655	Variable condenser
C20	20102	Condensers, electrolytic, 20 mfd, 16 mfd, 16 mfd, 350 volts
T1, T10, T4	1705	Condensers, electrolytic, 25 mfd, 25 volts
R9	2470	Control, volume, .5 megohm with switch
R16	2521	Control, tone, .25 megohm with switch
	2521	Dist cord
	4870	Dial scaler
	4140	Dial pointer
	4639	Knob, tuning off-on
	39138	Knob, SW, BC
	39139	Knob, tuning
	39140	Knob, volume
	39141	Lamp, dial #47 (2)
	4911	1000 ohm, 1/2 watt
R1		2200 ohm, 1/2 watt
R2		47 ohm, 1/2 watt
R3		22,000 ohm, 1/2 watt
R4		10,000 ohm, 1/2 watt
R5		2.2 megohm, 1/2 watt
R7		47,000 ohm, 1/2 watt
R6, R8		220,000 ohm, 1/2 watt
R11		300 ohm, 1 watt, wire wound
R13		1500 ohm, 1 watt, wire wound
R14		400 ohm, 1 watt, wire wound
R15		10 megohm, 1/2 watt
R10, R12		.5 megohm, 1/2 watt
	8107	Socket, pilot lamp (2)
	3784	Switch, band, BC - SW
	5864	Speaker, 5" output transformer
	1089	Transformer, 5" power #6
	3323	Transformer, I.F. Input
	3523	Transformer, I.F. Output

MANUAL OF 1947 MOST-OFTEN-NEEDED RADIO DIAGRAMS

AIR-KING PRODUCTS CO., Inc.

MODEL #4604-A

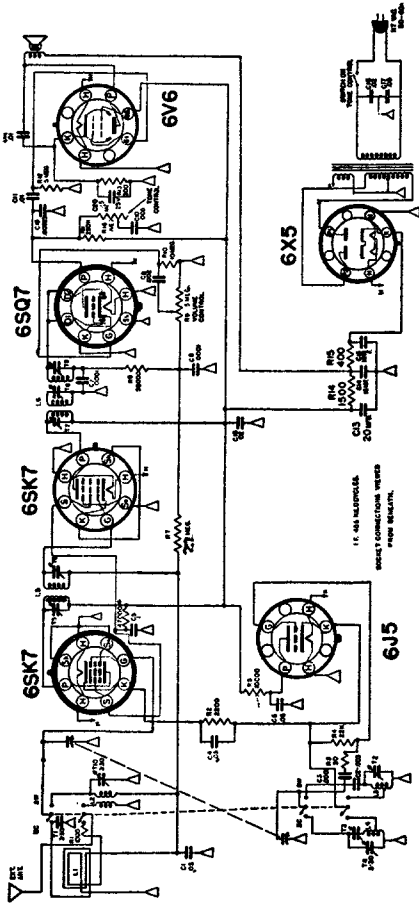

ALIGNMENT PROCEDURE

- Output meter connection.....Across voice coil
- Output meter reading to indicate 1/2 watt.....1.25V for 3.2 Ohm voice coil
- Connection of generator ground.....Receiver chassis
- Generator modulation.....Approximately 30% @ 400 cycles
- Position of volume control.....Fully clockwise
- Position of tone control.....High position

WAVE BAND SW.	GEN. FREQ.	GEN. CONN.	DUMMY ANT.	TRIMMERS ADJ. IN ORDER SHOW	TRIMMER FUNCT.
B. C.	540 kc	455 kc	6SK7 Grid	.1 mfd	I. F.
	1500 kc	1500 kc	* note		
	600 kc	600 kc	* note		
S. W.	1500 kc	1500 kc	* note		
	18 mc	18 mc	Ant. Post	RMA Standard	Osc.
			All Wave		Osc.
	16 mc	16 mc	Ant. Post	RMA Standard	Ant.
			All Wave		

NOTE:

If two peaks can be had the correct one is with the trimmer screw further out, the other peak is the image.
 * Connect a piece of insulated wire to the generator output terminal and place the wire near the loop. Do not make a direct connection.

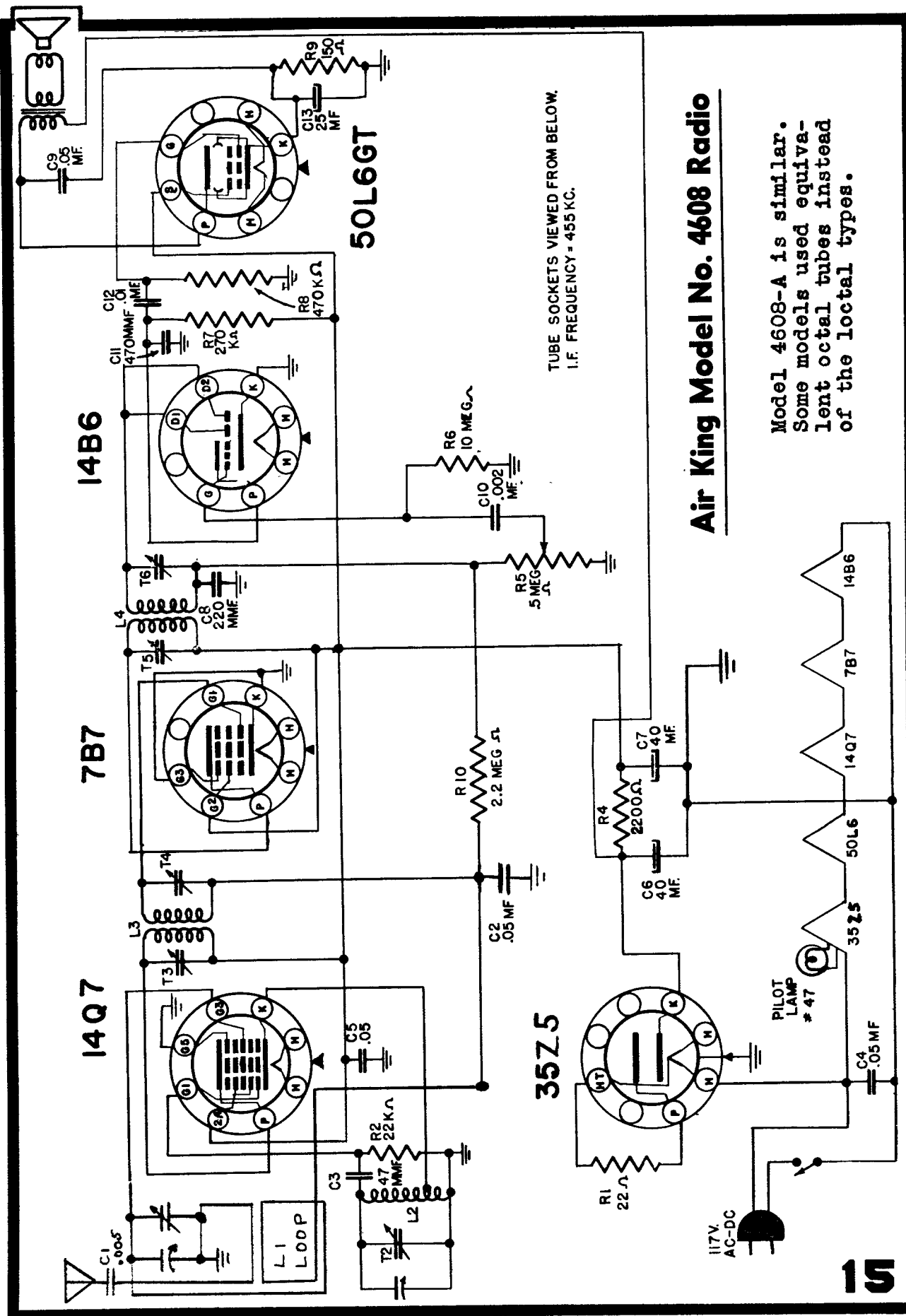

Air King Model No. 4608 Radio

Model 4608-A is similar. Some models used equivalent octal tubes instead of the loctal types.

MANUAL OF 1947 MOST-OFTEN-NEEDED RADIO DIAGRAMS

AIR KING Model 4625 3-Tube Amplified Phonograph

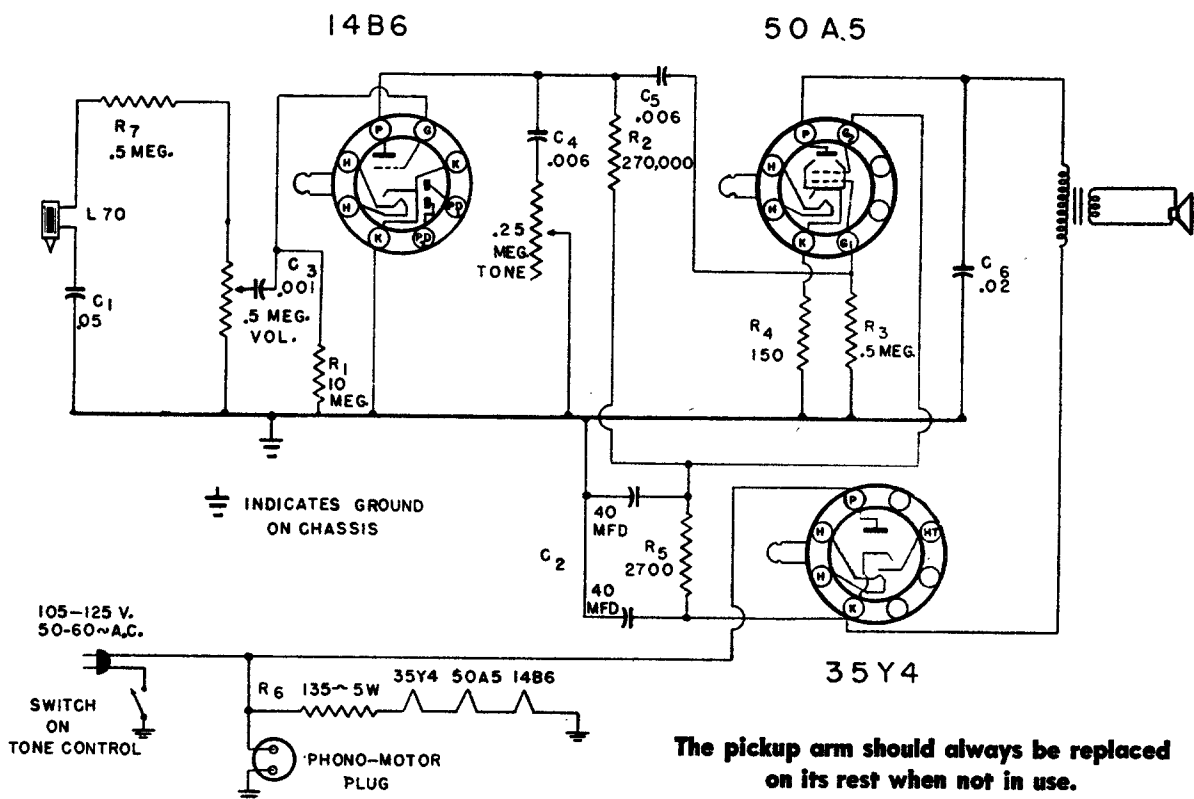

NOISY RECORDS: A background of noise and scratching indicates worn records. Poor tone may be evidence of a worn needle. Some records will wear longer than others, even if kept equally clean. This is due to quality of manufacture, care given the records, and to the kind of music recorded.

CAUTION: The lead wire which emerges from the rear of the tone arm and goes through the motor board is arranged so that it will not restrict the free movement of the tone arm across the record. It is important that this wire be free and loose at all times. Do not attempt to push the excess wire through the panel. Remove clip from stem before placing records on turntable.

PARTS LIST

Schematic Location	Part No.	Description	Schematic Location	Part No.	Description
	T454	Cabinet		18111	Plug, speaker, female
	62180	Cover, back		18112	Plug, motor, male
C4, C5	1971	Condenser, .006 mfd, mica		18113	Plug, motor, female
C1	1967	Condenser, .05 mfd, 200V		18104	Plug, phono, female
C2	2065	Condenser, electrolytic, 40-40 mfd, 150V		1861	Plug, phono, male
C3	1956	Condenser, .001 mfd	R6	2238	Resistor, 135 ohms, 5W, wire wound
C6	1963	Condenser, .02 mfd, 400V	R5	2378	Resistor, 2700 ohms, 1W
	2473	Control, Tone, with switch, 1/4 Meg.	R2	2361	Resistor, 278,000 ohms, 1/2W
	2472	Control, Volume, 1/2 Meg.	R4	2372	Resistor, 150 ohms, 1/2W
	5559	Cord, line	R3, R7	2353	Resistor, 500,000 ohms, 1/4W
	39145	Knob (2)	R1	2335	Resistor, 10 Meg., 1/4W
	6414	Motor	R8	2363	Resistor, 220,000 ohms, 1/4W
	6342	Pick-up arm with cartridge, L78	5855	5855	Speaker, 5", with output trans.
	18103	Plug, speaker, male	6417	6417	Turntable, 9"
			54228	54228	Needle, Fidelity Master

MANUAL OF 1947 MOST-OFTEN-NEEDED RADIO DIAGRAMS

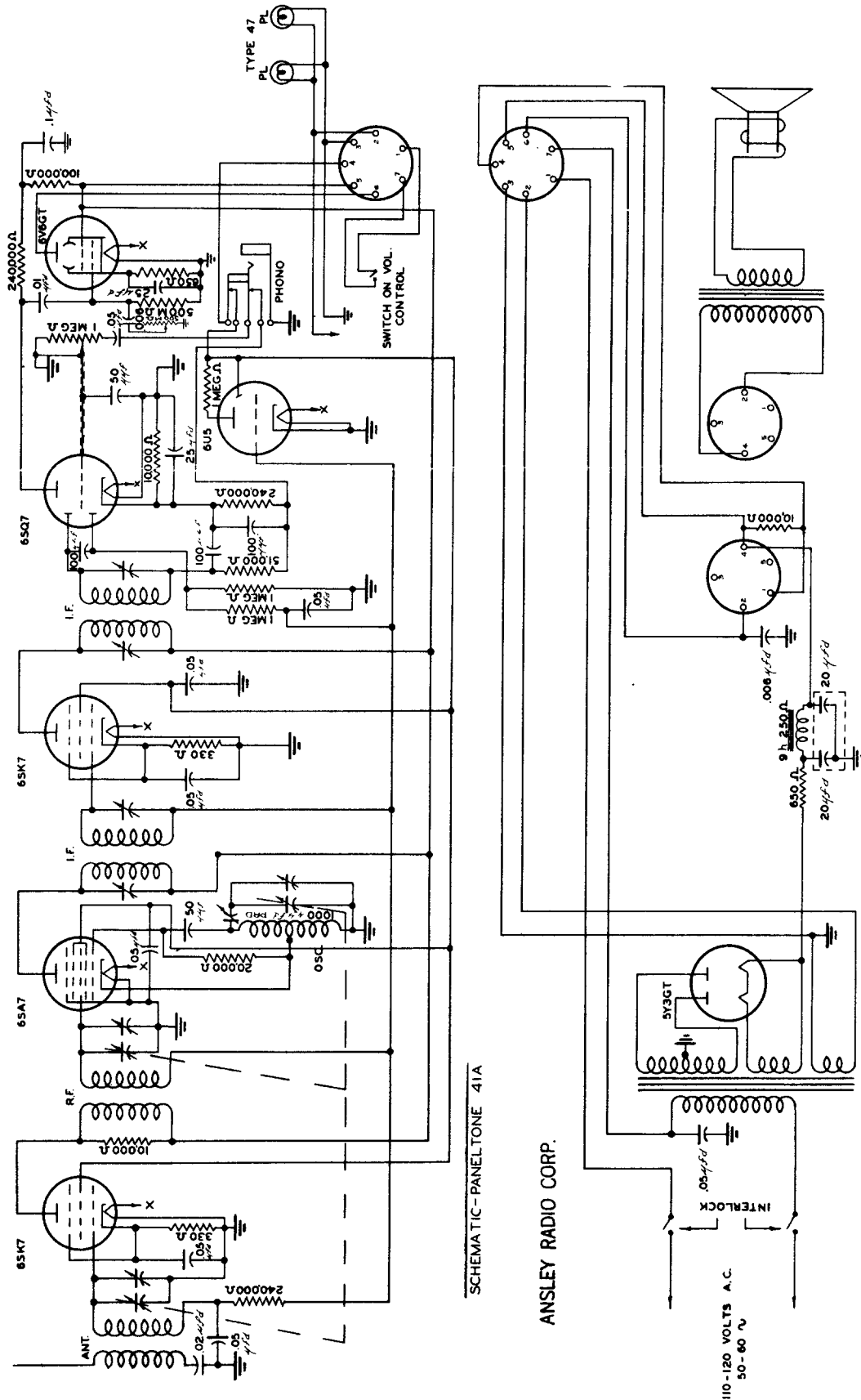

MODEL 5P19

Belmont Radio

1A7GT CONVERTER
1N5GT I.F. AMP.

1H5GT 2ND DET. 19 AUDIO A.L.C.

1A5GT OUTPUT

Intermediate Freq. 455 kc.

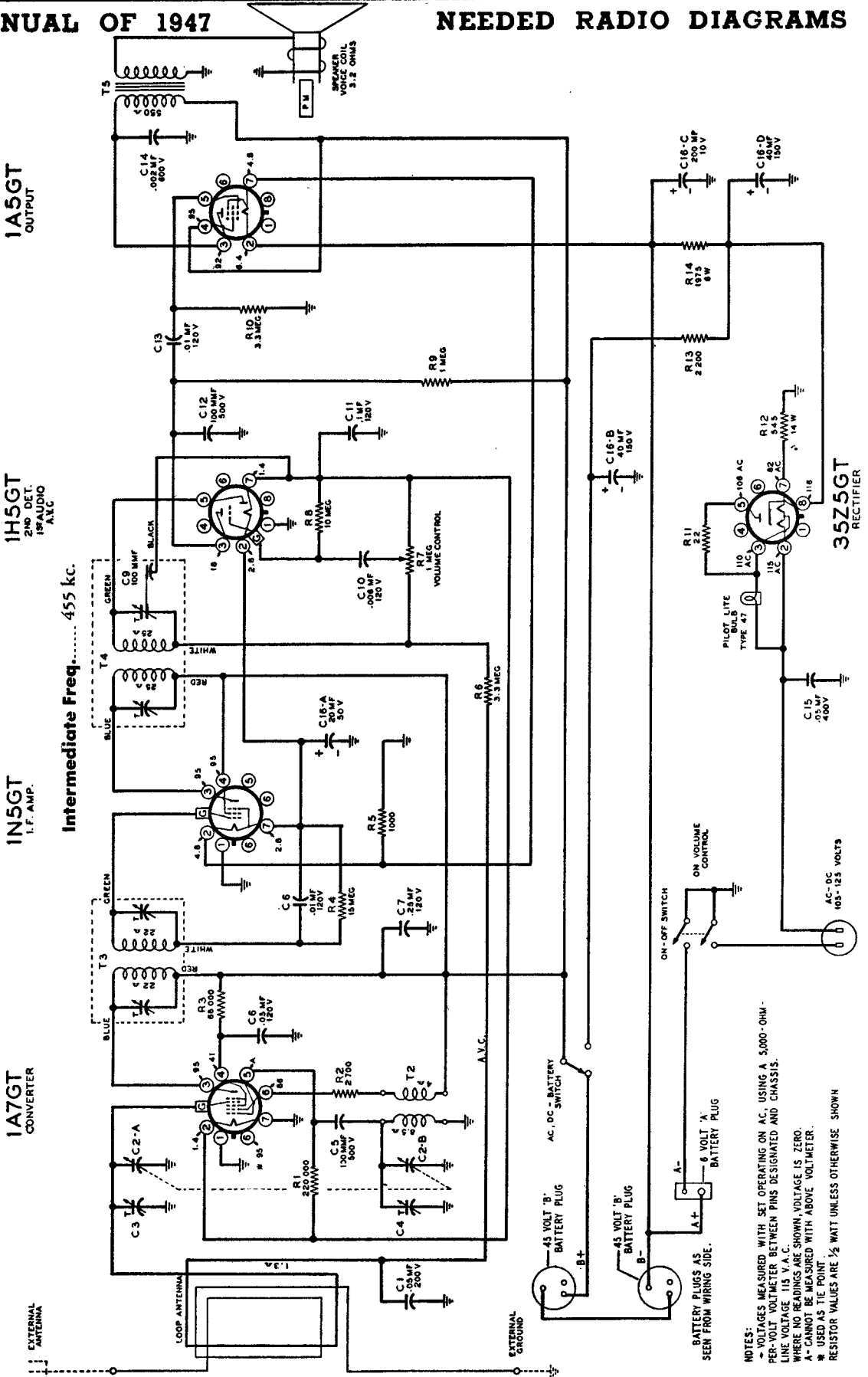

NOTES:
 * VOLTAGES MEASURED WITH SET OPERATING ON AC USING A 5000-OHM-
 PER-VOLT VOLTMETER BETWEEN PINS DESIGNATED AND CHASSIS.
 † LINE VOLTAGE 115 V. A. C.
 ‡ WHERE NO READINGS ARE SHOWN VOLTAGE IS ZERO.
 § A-C CANNOT BE MEASURED WITH ABOVE VOLTMETER.
 ¶ USED AS TIE POINT
 ** RESISTOR VALUES ARE 1/2 WATT UNLESS OTHERWISE SHOWN

Belmont Radio MODEL 5D110

**50B5
OUTPUT**

**12AT6
2ND DET AVC
& 1ST AUDIO**

**12BD6
IF AMP**

**12BE6
CONVERTER**

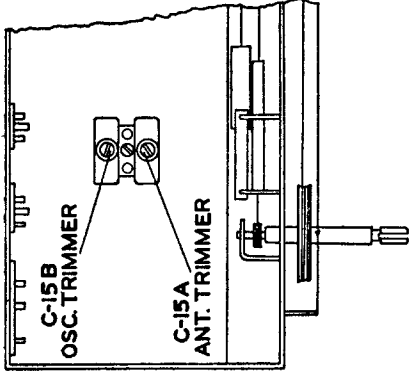
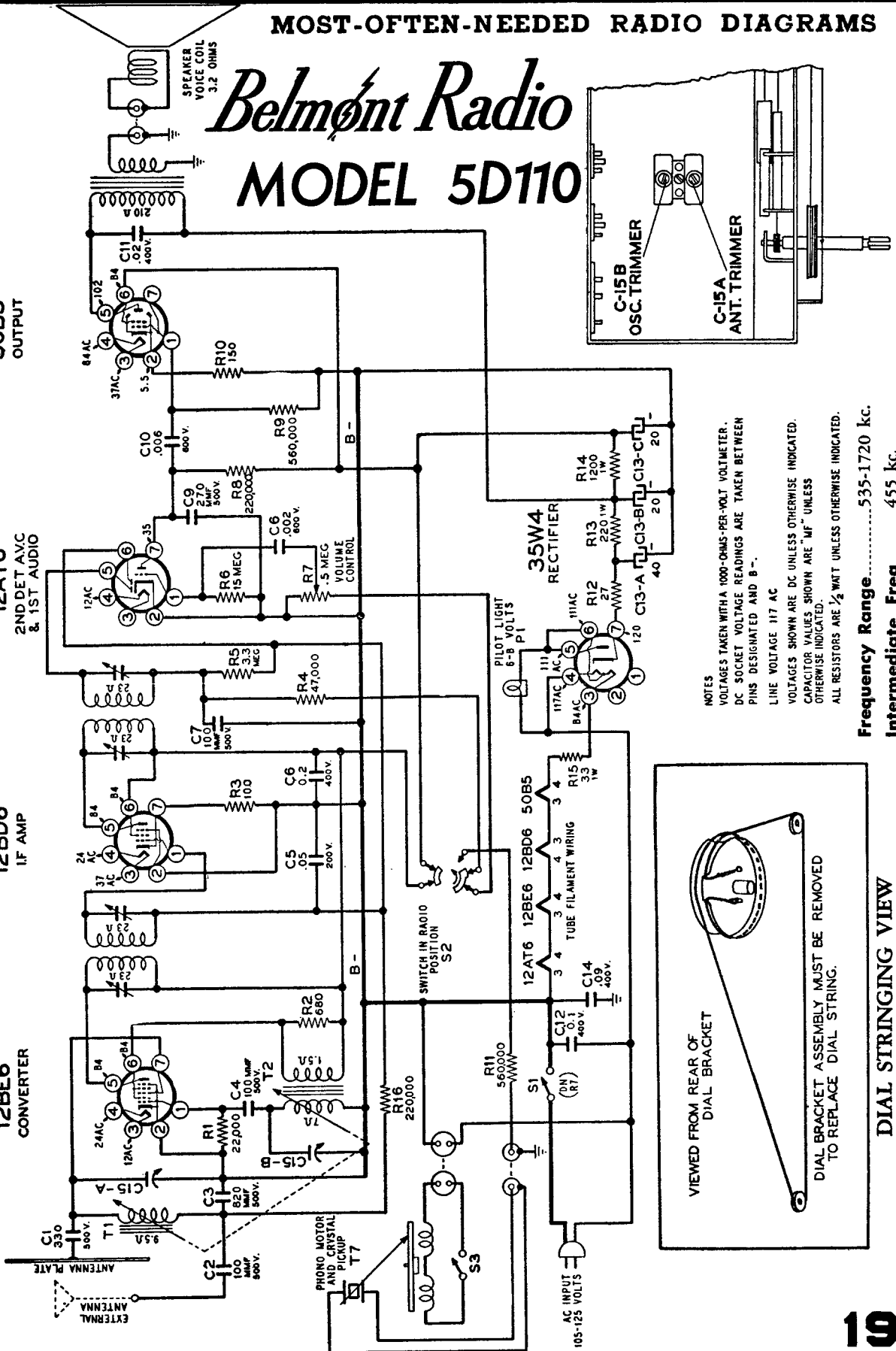

NOTES
 VOLTAGES TAKEN WITH A 1000-OHMS-PER-VOLT VOLTMETER.
 DC SOCKET VOLTAGE READINGS ARE TAKEN BETWEEN PINS DESIGNATED AND B-.
 LINE VOLTAGE 117 AC
 VOLTAGES SHOWN ARE DC UNLESS OTHERWISE INDICATED.
 CAPACITOR VALUES SHOWN ARE "MF" UNLESS OTHERWISE INDICATED.
 ALL RESISTORS ARE 1/2 WATT UNLESS OTHERWISE INDICATED.

Frequency Range 535-1720 kc.
Intermediate Freq. 455 kc.

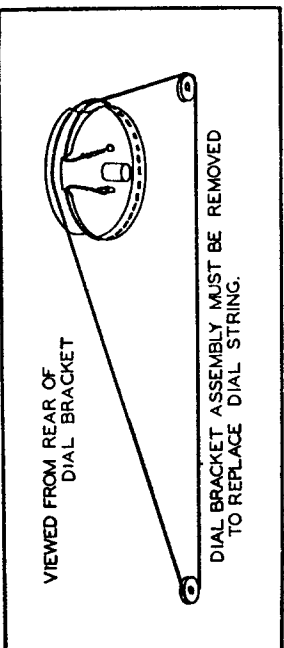

DIAL STRINGING VIEW

Bendix Radio

MODELS 636A 636C, & 636D

CONDITIONS OF MEASUREMENTS
 LINE VOLTAGE 117 A.C. ZERO SIGNAL INPUT VOL. CONT. MIN. SOCKET RESISTANCE TO COMMON BUS ±10% D.C. AT 20,000 Ω/V A.C. AT 1,000 Ω/V

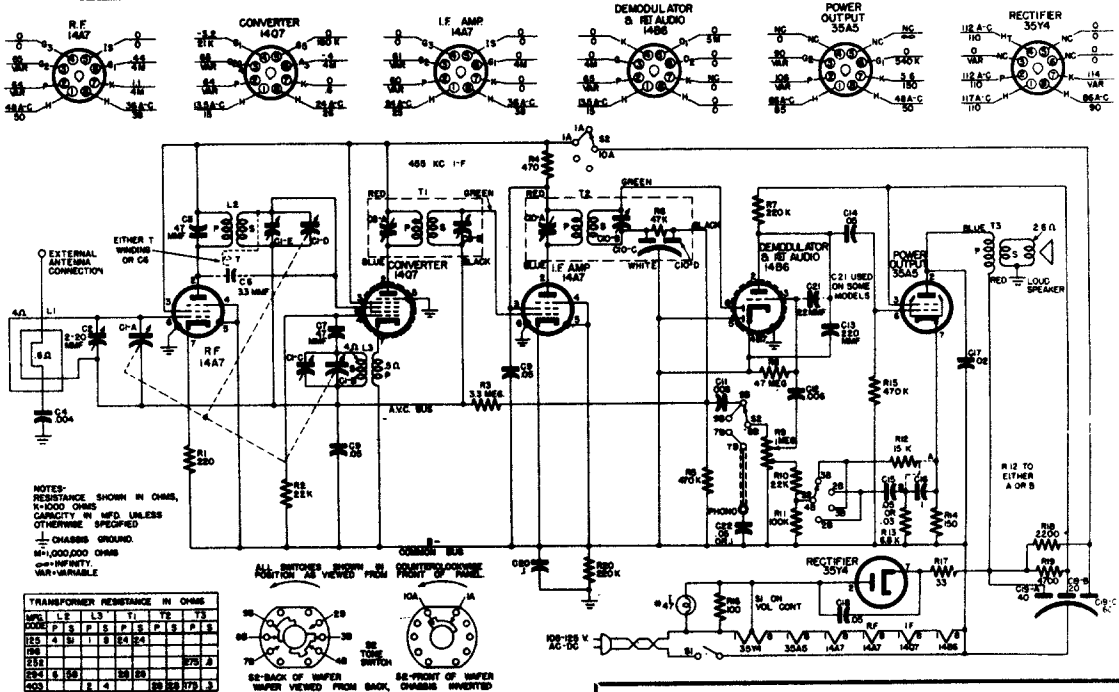

Alignment Procedure

Connect line cord plug to 117 volt, 60 cycles AC power source. Set volume control at maximum clockwise position and tone control (S2) in counterclockwise position. Connect output meter across voice coil. Adjust dial pointer by turning tuning control fully counterclockwise and sliding dial pointer on dial cord until it is exactly 2 3/16" from left end of dial back plate. Make all adjustments in order given in table and for maximum output. Dial Pointer Positions given measured from left hand end of dial back plate. Keep input as low as possible at all times.

Precautions

An isolating transformer should be used between the power supply and the receiver if any of the test equipment is AC operated. The use of isolating capacitors is not recommended as AC through the capacitor may introduce hum modulation, and if the capacitors should break down the test instruments will likely be damaged.

Circuit Aligned	Input Freq:	Dial Pointer Position	Adjustments
IF	*455 KC	Max. to right	C10b, C10a C8b, C8a
OSC.	**1475 KC	6 3/4"	C1c
RF	**1475 KC **965 KC **580 KC	6 3/4" 5 2-23/32"	C1c, C2 Check Calib.

* Applied to Antenna input .1 mfd. or less.

** Applied to Antenna input through 50 mmf. or less.

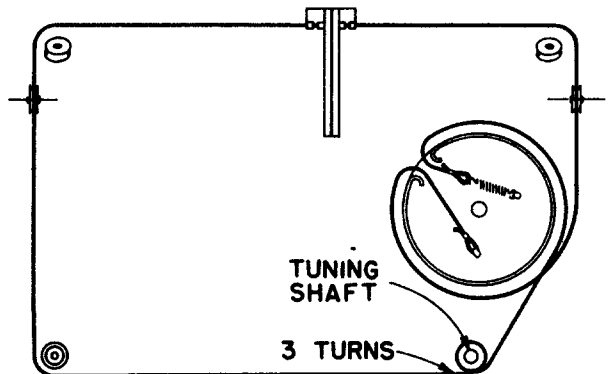
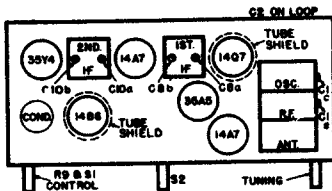

MANUAL OF 1947 MOST-OFTEN-NEEDED RADIO DIAGRAMS



MODEL 6D120

ALIGNMENT PROCEDURE

Output meter across 3.2-ohm output load.
Align for maximum output. Reduce input as needed to keep output near 0.4 volts.
Volume control at maximum for all adjustments.
Connect ground post of signal generator to B- of radio.

Chassis must be removed from cabinet for proper alignment. Slight adjustments of the oscillator and antenna circuits can be made, without removing the chassis, through two holes provided on the bottom of the cabinet. The screws can be reached with a long screwdriver.

SIGNAL GENERATOR			TUNER SETTING	ADJUST FOR MAXIMUM OUTPUT (in order shown)
Frequency	Dummy Antenna	Connection to Radio		
455 kc	.1 mf	Grid (pin 8) of 12SA7	Plates out of mesh	Trimmers on output and input I.F. cans
1650 kc	.1 mf	Grid (pin 8) of 12SA7	Plates out of mesh	Oscillator trimmer C7 on bottom of gang
1400 kc	200 mmf	See note below	Set dial at 1400 kc	Antenna trimmer C4 on bottom of gang

Lay output lead of generator in back of loop antenna. Turn up generator output. Loop will pick up energy.

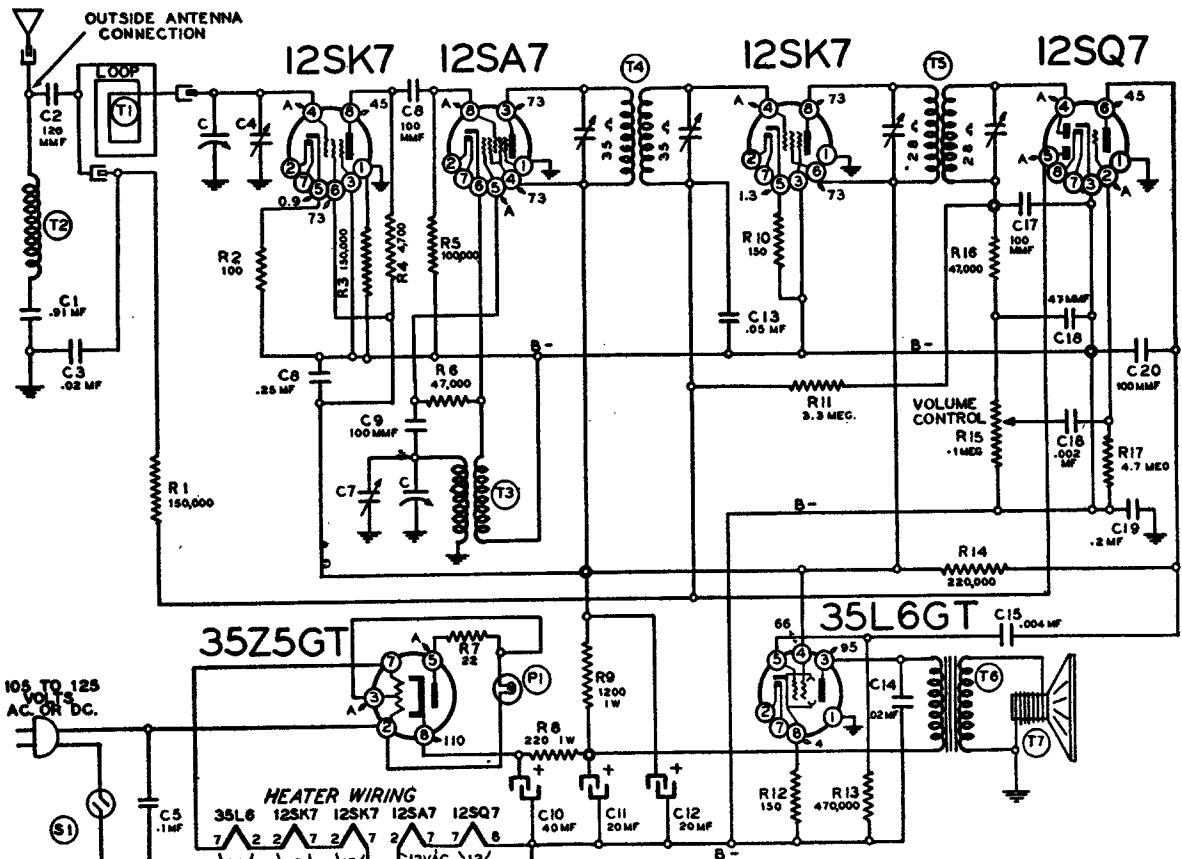

- VOLTAGE MEASURED WITH A 1000-OHM-
PER-VOLT VOLTMETER BETWEEN PINS
DESIGNATED AND B-
- A- CANNOT BE MEASURED.
- LINE VOLTAGE 117 VAC

Bendix Radio

MODELS 676B, 676C, & 676D

CONDITIONS OF MEASUREMENTS
 LINE VOLTAGE 117 A.C. ZERO SIGNAL INPUT VOL. CONT. MIN. SOCKET VOLTAGE RESISTANCE TO COMMON GROUND DC AT 20,000 Ω/V AC AT 1000 Ω/V

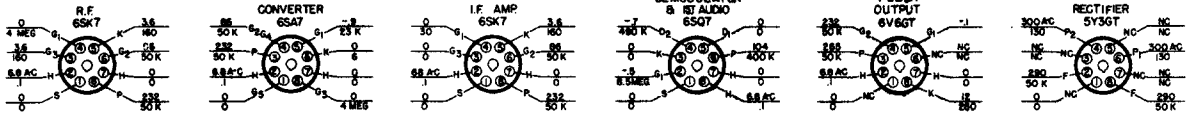

MFG	T 3	T 4
176	17	15
196	15	13
294	15	25
306	23	21

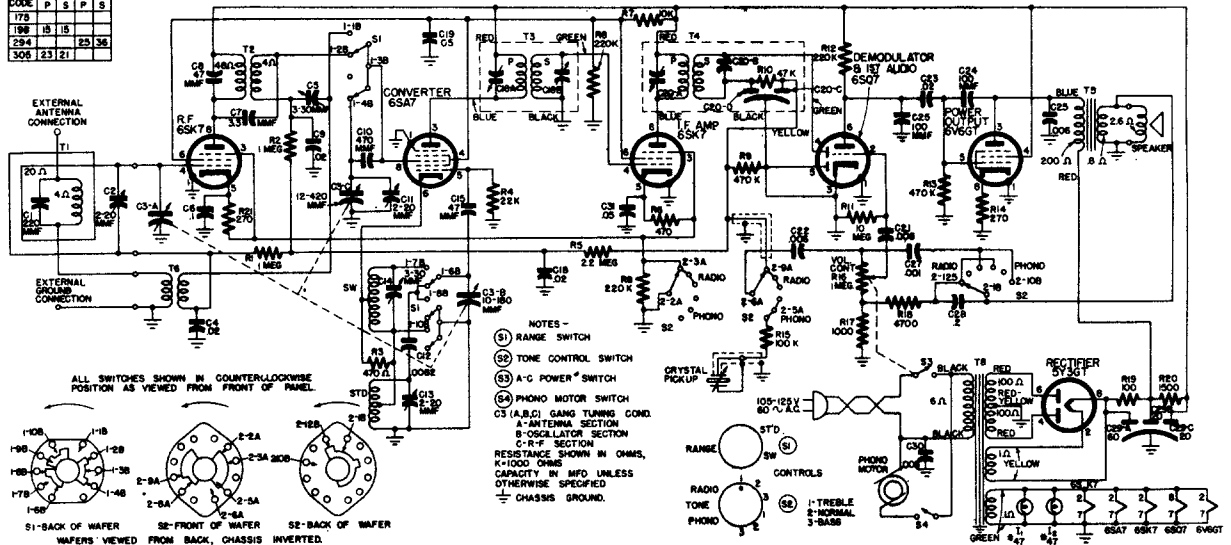

- NOTES -
- (S1) RANGE SWITCH
 - (S2) TONE CONTROL SWITCH
 - (S3) A-C POWER SWITCH
 - (S4) PHONO MOTOR SWITCH
 - C3 (A,B,C) GANG TUNING COND.
 - A-ANTENNA SECTION
 - B-OSCILLATOR SECTION
 - C-R-F SECTION
 - RESISTANCE SHOWN IN OHMS, K-1000 OHMS
 - CAPACITY IN MFD UNLESS OTHERWISE SPECIFIED
 - ⊥ CHASSIS GROUND.

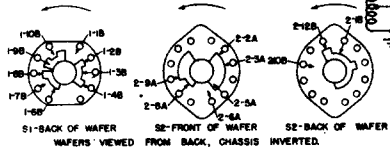

Alignment Procedure

Connect line cord plug to 117 volt, 60 cycles AC power source. Set volume control at maximum clockwise position and tone control (S2) in counterclockwise (Radio 1) position. Connect output meter across voice coil. Adjust dial pointer by turning tuning control fully counterclockwise and sliding dial pointer on dial cord until it is exactly 2 3/4" from left end of dial back plate. Make all adjustments in order given in table and for maximum output. Dial Pointer Positions given measured from left hand end of dial back plate. Keep input as low as possible at all times. Range switch (S1) in ST'D position except as noted in table.

Circuit Aligned	Input Frequency	Dial Pointer Position	Adjustments
IF	* 455KCS	Max. to right	C20B, C20A C16B, C16A
OSC Broadcast	**1475KCS	7 3/4"	C13
RF Broadcast	**1475KCS **965KCS **580KCS	7 3/4" 5 15/16" 3 3/8"	C11, C2 Check Calib.
+OSC Shortwave	**11MCS	7 3/4"	C14
+RF Shortwave	**11MCS 9MCS 6MCS	7 3/4" 6 9/16" 3 1/2"	C5 Check Calib.

*Applied to antenna through .1 mfd. or less.
 **Applied to antenna through 200 mmf. or less.
 +Range switch (S1) in SW position.

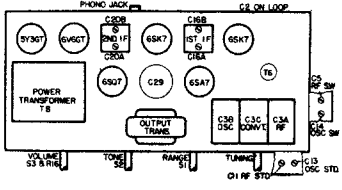
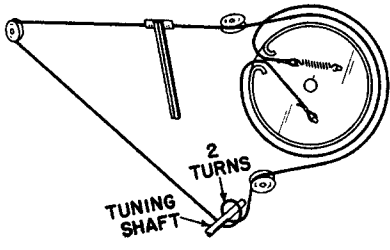

MANUAL OF 1947 MOST-OFTEN-NEEDED RADIO DIAGRAMS

SOCKET VOLTAGE RESISTANCE TO COMMON BUS $\pm 10\%$. LINE VOLTAGE - 117 V. A.C. ZERO SIGNAL INPUT. VOL. CONT. MIN. D.C. AT 20,000 Ω/V . A.C. AT 1,000 Ω/V .

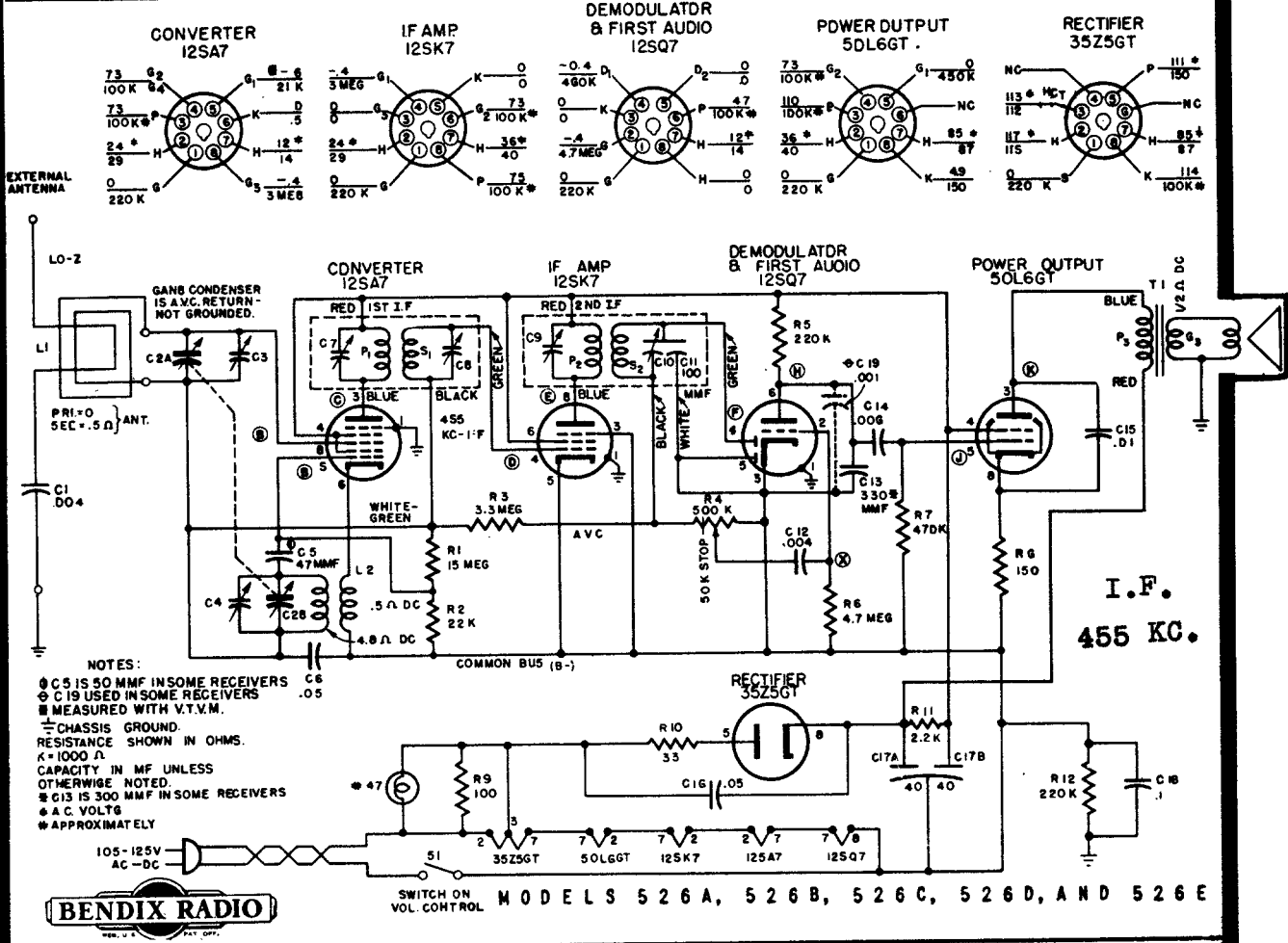

COMPONENTS OF MEASUREMENTS: LINE VOLTAGE $\pm 10\%$ C ZERO SIGNAL INPUT VOL. CONT. MIN. SOCKET VOLTAGE RESISTANCE TO COMMON BUS $\pm 10\%$ D.C. AT 20,000 Ω/V A.C. AT 1,000 Ω/V

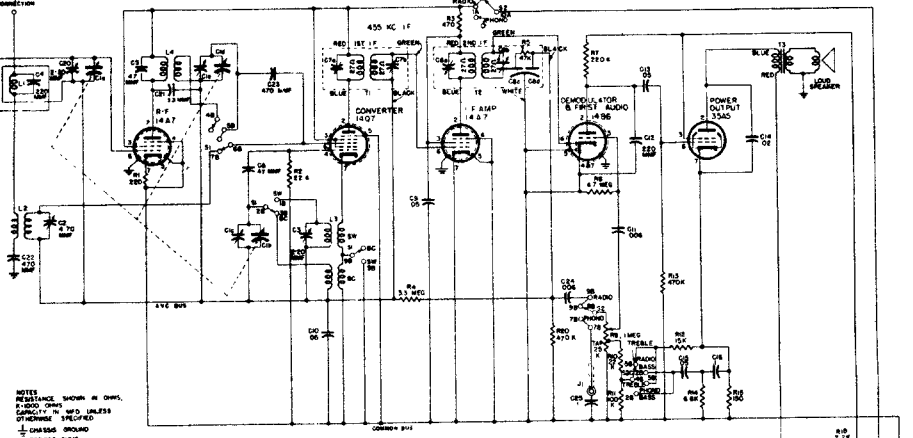
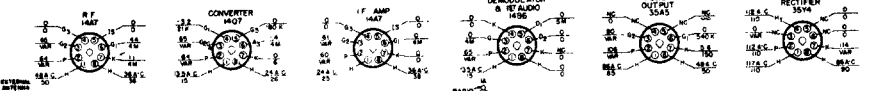

TRANSFORMER RESISTANCE IN OHMS

WINDING	12.5V	17.5V	25V	35V	50V	75V	100V
1-2	12.5	17.5	25	35	50	75	100
1-3	12.5	17.5	25	35	50	75	100
1-4	12.5	17.5	25	35	50	75	100
1-5	12.5	17.5	25	35	50	75	100
1-6	12.5	17.5	25	35	50	75	100
1-7	12.5	17.5	25	35	50	75	100
1-8	12.5	17.5	25	35	50	75	100
1-9	12.5	17.5	25	35	50	75	100
1-10	12.5	17.5	25	35	50	75	100
1-11	12.5	17.5	25	35	50	75	100
1-12	12.5	17.5	25	35	50	75	100

Bendix
Radio
MODEL
626-A

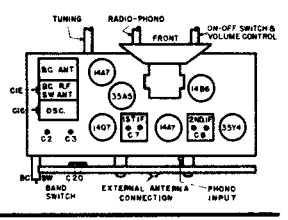

MANUAL OF 1947 MOST-OFTEN-NEEDED RADIO DIAGRAMS

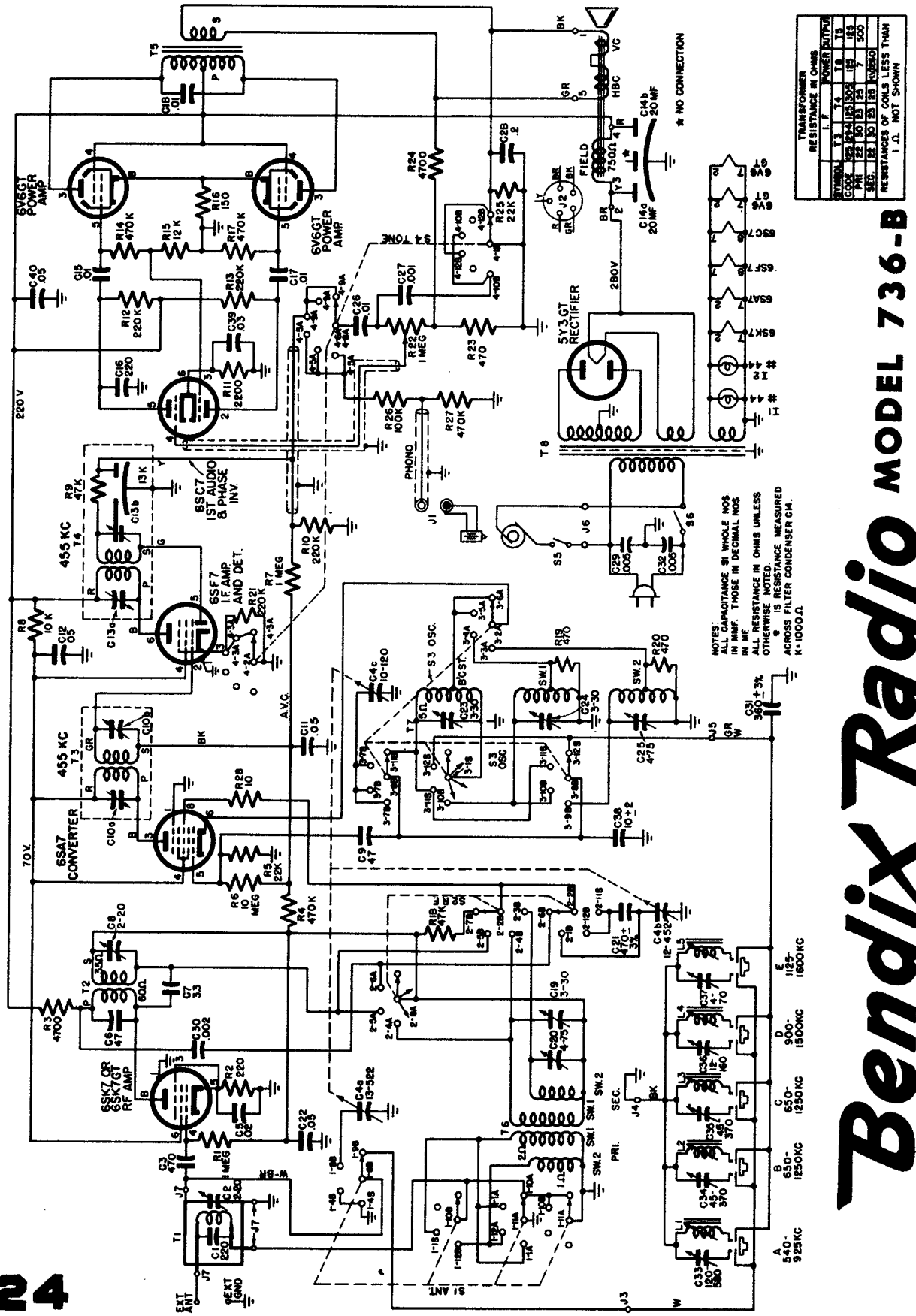

Bendix Radio MODEL 736-B

CROSLEY MODEL 56FC

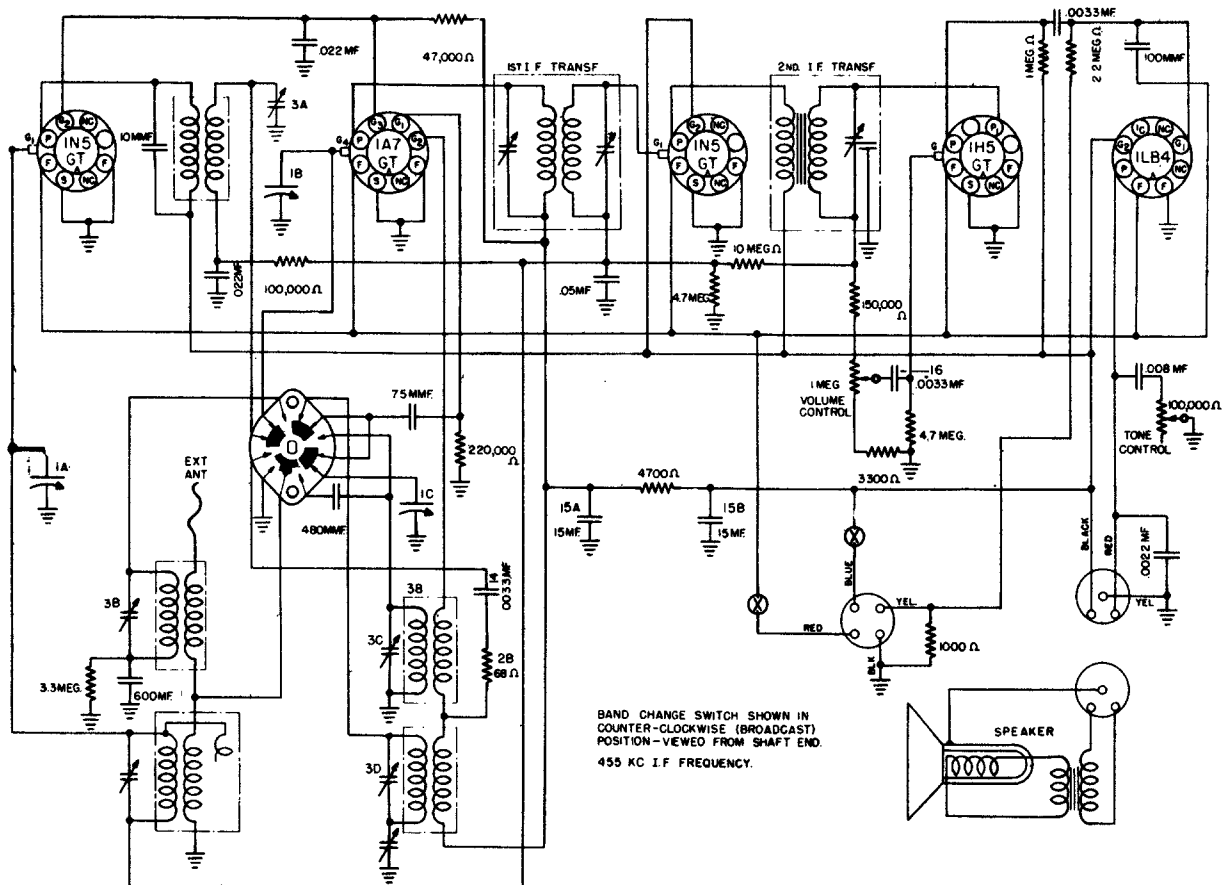

SCHEMATIC DIAGRAM—MODEL 56FC

SOCKET VOLTAGE CHART

1. THESE ARE BOTTOM VIEWS OF SOCKETS
2. MEASURE VOLTAGE FROM SOCKET LUG TO CHASSIS (GROUND).
3. THESE VOLTAGES MEASURED USING AN ELECTRONIC VOLTMETER.
4. WJ - WIRING JUNCTION.
5. NC - NO CONNECTION.
6. SOCKET VOLTAGE TOLERANCE, 10%.

DET. A.V.C. 1ST A.F.

R.F. AMPLIFIER

POWER OUTPUT

I.F. AMPLIFIER

MIXER

MANUAL OF 1947 MOST-OFTEN-NEEDED RADIO DIAGRAMS

CROSLLEY

MODELS: 56 PA, 56 PB

TYPE: Five-tube, combination, battery Portable and AC-DC Superheterodyne.

FREQUENCY RANGE: 540 to 1600 kilocycles.

INTERMEDIATE FREQUENCY: 455 kc.

POWER SUPPLY: AC-DC or BATTERY.

VOLTAGE RATING: AC-DC, 110 to 120 volts.
Battery "A" 7½ volts "B" 90 volts.

POWER OUTPUT: 180 M.W. maximum.

SOCKET VOLTAGE CHART

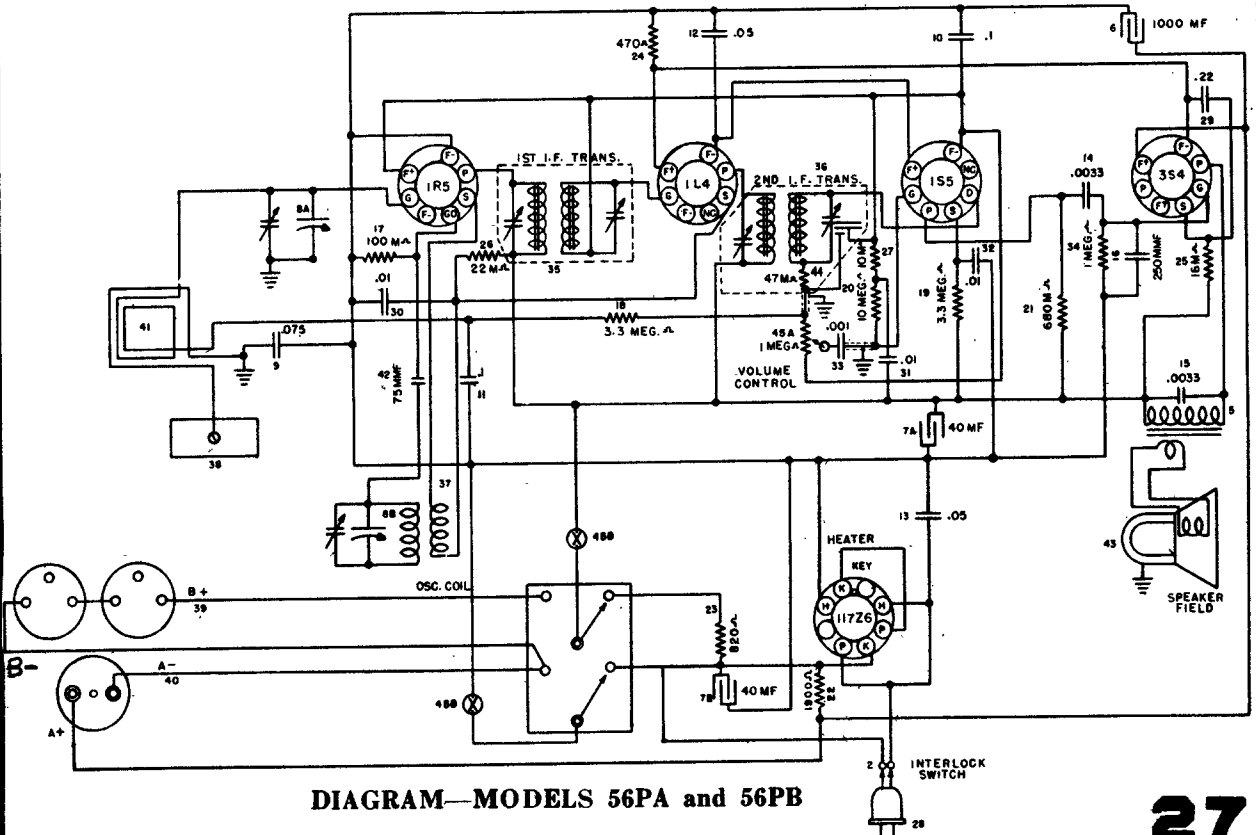
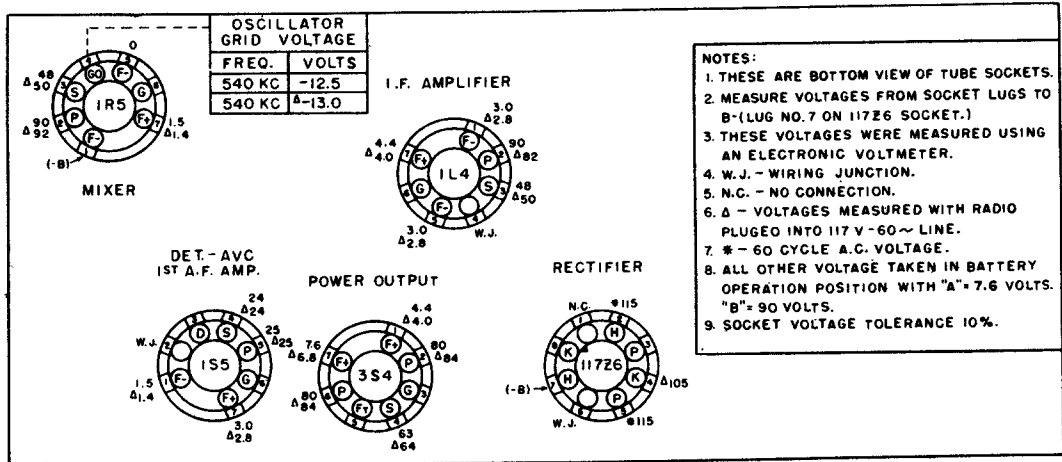

MANUAL OF 1947 MOST-OFTEN-NEEDED RADIO DIAGRAMS

CROSLLEY

MODELS 56PA and 56PB

ALIGNMENT PROCEDURE

Turn the tuning condenser to the completely closed position against the stop and set the dial pointer to the reference line at the end of the dial scale.

Connect the output meter across the speaker voice coil.

Connect the high side of the signal generator to the external antenna wire of the loop, that connects to the terminal screw on the bottom of the cabinet, as indicated in the alignment chart. Connect signal generator ground through a 0.1 mt. condenser to B—. (No. 1 pin on 1R5 tube).

Turn the volume control on full and adjust the signal generator output to produce approximately mid-scale deflection of the output meter, but maintain signal generator output as low as possible to prevent AVC action in the receiver.

Alignment Sequence	Signal Generator Output			Position of Tuning Dial KC	Adjust for Maximum Outout
	Frequency in KC	In Series with	To		
1	455	200 mmf.	Ant.	1620	A & B
2	1620	200 mmf.	Ant.	1620	C
3	1400	200 mmf.	Ant.	1400	*D

***NOTE:** Batteries should be placed against battery stop in front half of cabinet

The material presented on this page has been prepared by and is printed through the courtesy of THE CROSLLEY CORP.

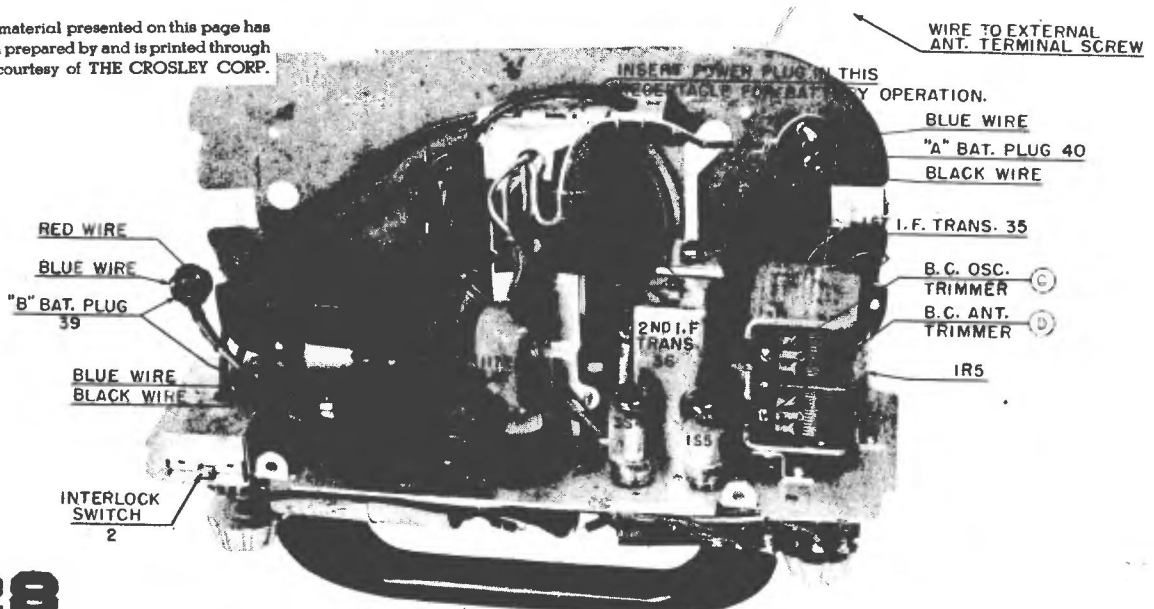

MANUAL OF 1947 MOST-OFTEN-NEEDED RADIO DIAGRAMS

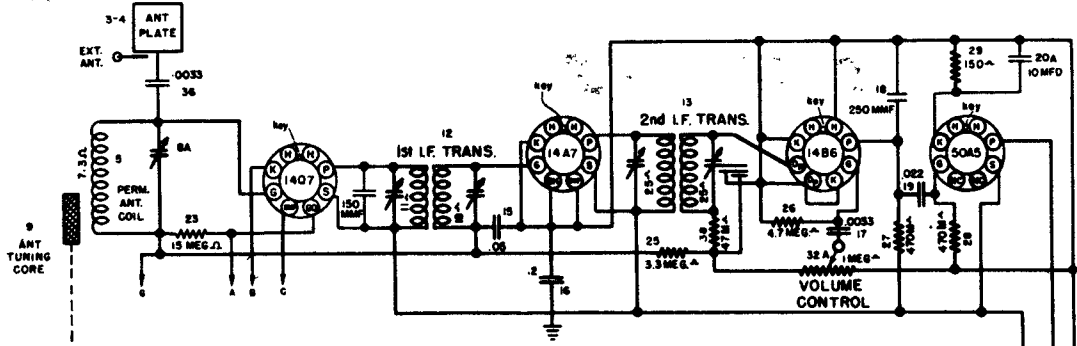

Please refer to the next page.

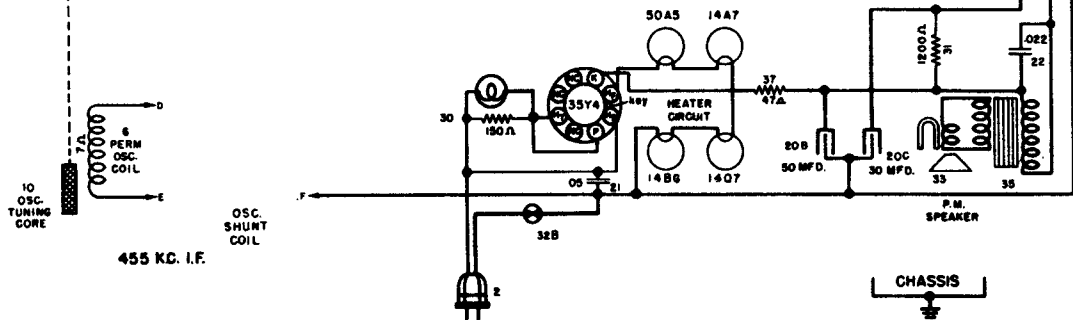

SCHMATIC DIAGRAM—MODEL 56TG, 56TH, 56TJ (LOCTAL)

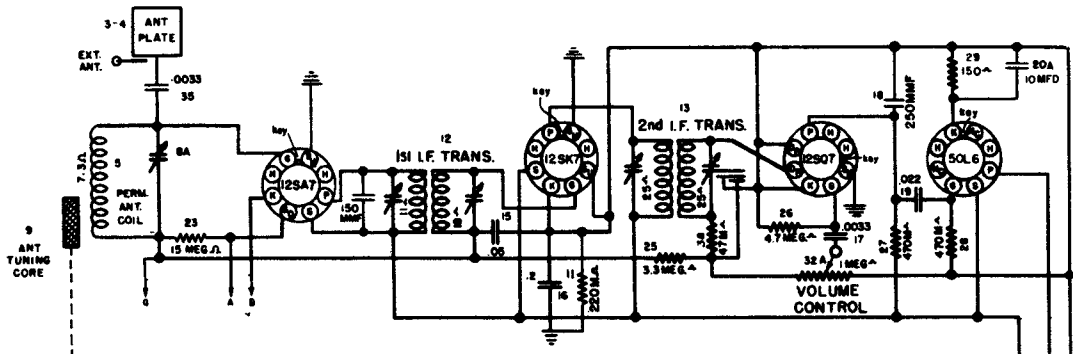

CROSLEY

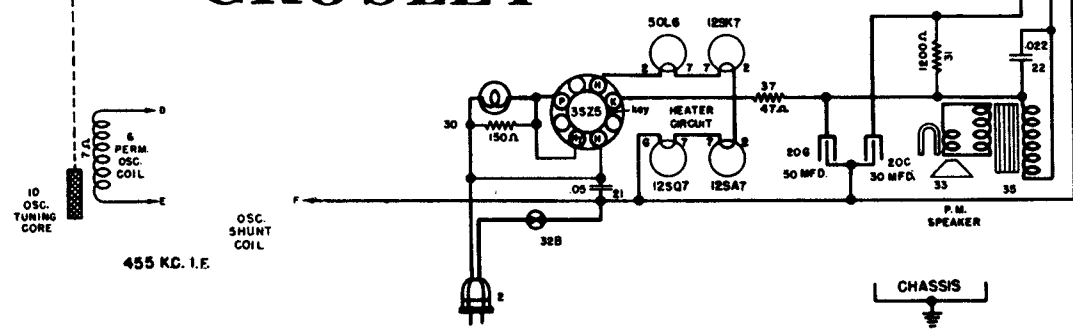

SCHMATIC DIAGRAM—MODEL 56TG-O, 56TH-O, 56TJ-O (OCTAL)

CROSLEY

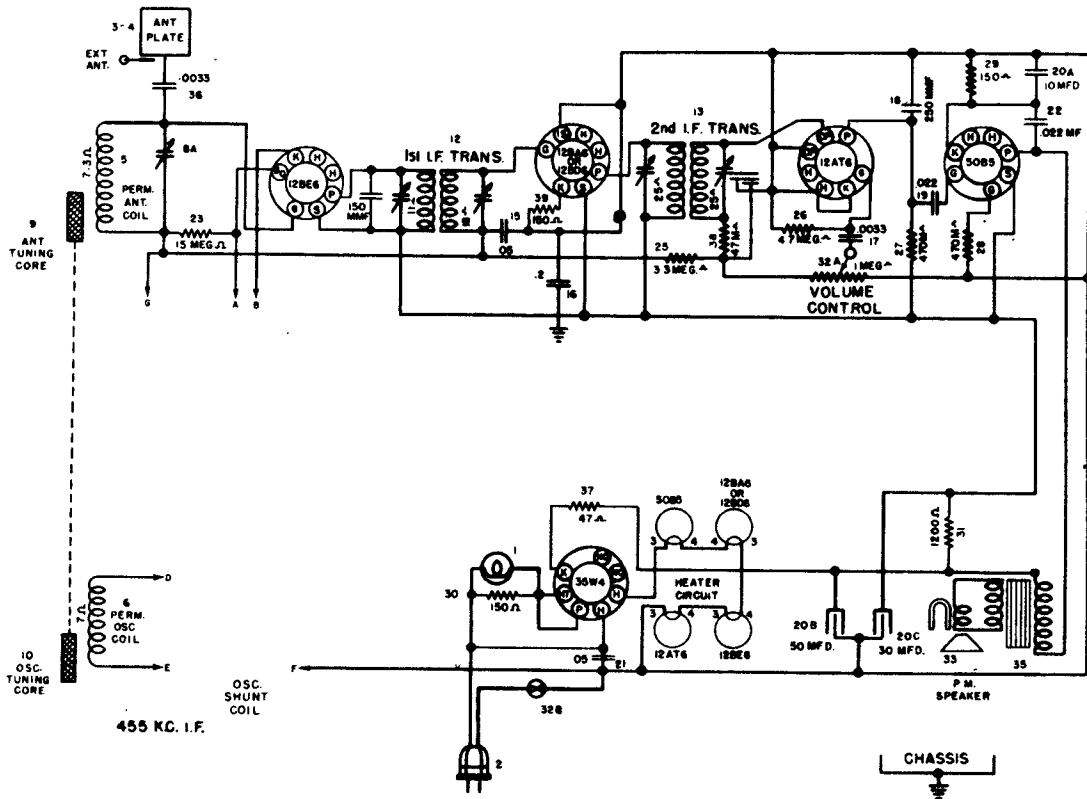

SCHEMATIC DIAGRAM—MODEL 56TG-M, 56TH-M, 56TJ-M (MINIATURE)

Select oscillator shunt coil circuit which corresponds to the model radio you are servicing. Connection G is used in the 3rd production sets.

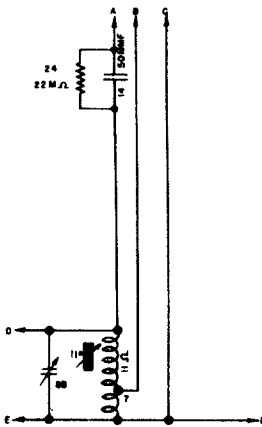

THE ABOVE OSCILLATOR SHUNT COIL IS USED IN THE FIRST PRODUCTION MODELS IT IS MOUNTED ON THE PERMEABILITY TUNER AND USES AN ADJUSTABLE IRON CORE "C" IS NOT USED WITH A MINIATURE OR AN OCTAL TUBE

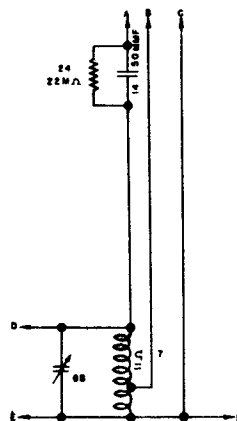

THIS OSCILLATOR SHUNT COIL IS USED IN THE SECOND PRODUCTION MODELS. IT IS MOUNTED ON THE REAR OF THE PERMEABILITY TUNER AND DOES NOT USE AN ADJUSTABLE IRON CORE "C" IS NOT USED WITH A MINIATURE OR AN OCTAL TUBE

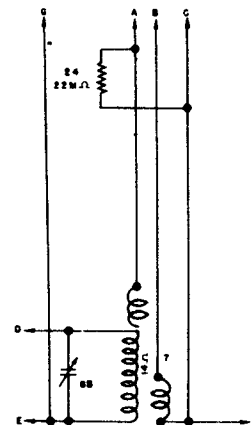

THIS OSCILLATOR SHUNT COIL IS USED IN THE THIRD PRODUCTION MODELS IT IS MOUNTED UNDER THE CHASSIS AND DOES NOT USE AN ADJUSTABLE IRON CORE. "C" IS NOT USED WITH A MINIATURE OR AN OCTAL TUBE

MANUAL OF 1947 MOST-OFTEN-NEEDED RADIO DIAGRAMS

MODEL 56TP

TUBE COMPLEMENT:

FREQUENCY RANGE: American Broadcast Band: 540 to 1600 kc. (Selector switch at A.)

Overseas Short-wave Band: 5.8 to 15 mc. (Selector switch at 0.)

INTERMEDIATE FREQUENCY: 455 kc.

POWER SUPPLY: 60 cycle a.c. only.

VOLTAGE RATING: 105-125 volts.

POWER CONSUMPTION: 35 watts nominal.

POWER OUTPUT: 1.5 watts minimum.

Type	Function
12SA7 (or GT/G)	Mixer
12SK7 (or GT/G)	I.F. Amplifier
12SQ7 (or GT/G)	Detector, AVC, 1st A.F. Amplifier
50L6GT	A.F. Power Output
35Z5GT/G	Rectifier

DIAL BULB: Type 47, 6.3 volts, .15 amp.

NOTE:

BAND	FREQUENCY	VOLTS
AMERICAN	540 KC	- 4.9
OVERSEAS	5.7 MC	- 3.8

I. F. AMPLIFIER

DET.-A.V.C.-1st A.F.

RECTIFIER

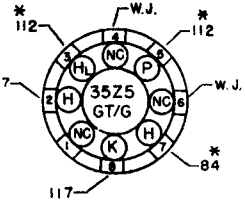
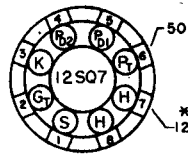
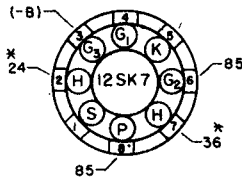

MIXER

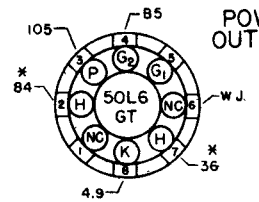
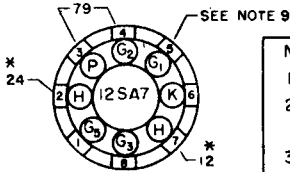

POWER OUTPUT

NOTES:

1. TUBE SOCKETS ARE BOTTOM VIEWS.
2. MEASURE VOLTAGES FROM SOCKET LUG TO -B (PIN 3 ON THE 12SK7).
3. VOLTAGES AS MEASURED WITH AN ELECTRONIC VOLTMETER
4. WJ - WIRING JUNCTION.
5. NC - NO CONNECTION
6. * - AC VOLTAGES
7. VOLTAGE TOLERANCE, 10 %
8. LINE VOLTAGE 117V, 60 AC

VOLTAGE CHART

The material presented on this page has been prepared by and is printed through the courtesy of THE CROSLY CORP.

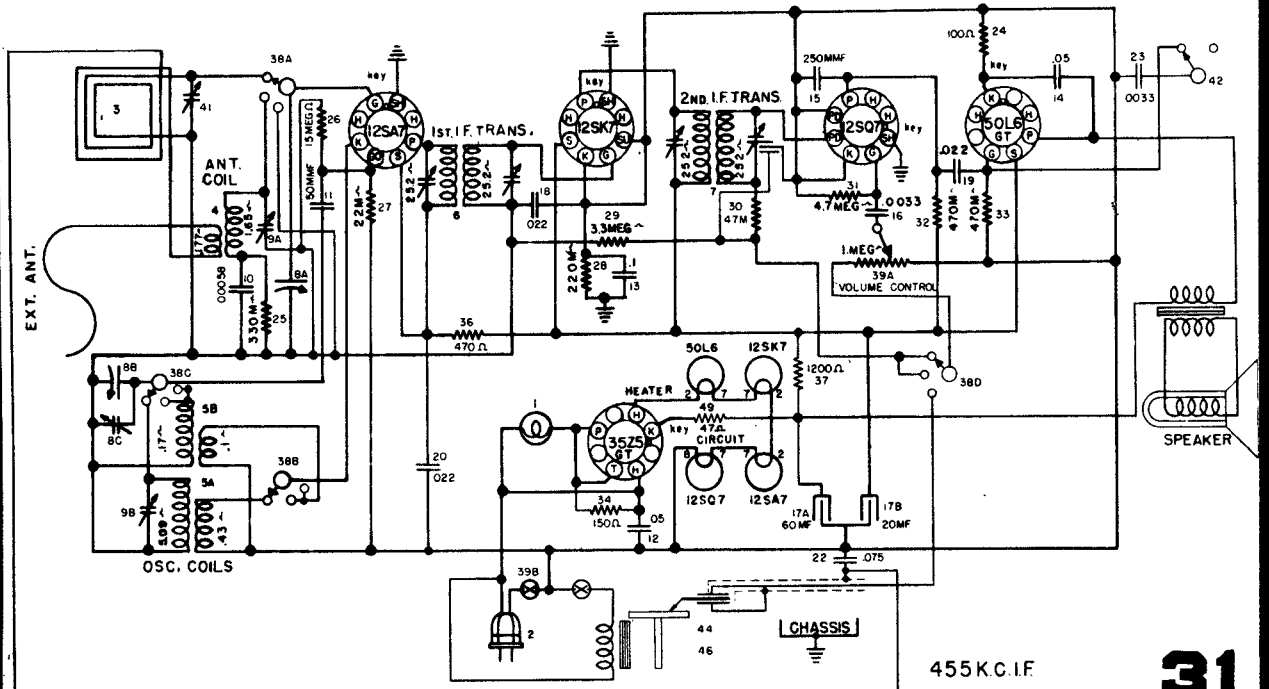

455K.C.IF

31

MANUAL OF 1947 MOST-OFTEN-NEEDED RADIO DIAGRAMS

Alignment Sequence	Signal Generator Output			Position of		Adjust for Maximum Output
	Frequency in kc.	In Series with	To	Band Switch	Tuning Dial	
1	455	200 mmf.	Ant.	Left	1,620	A & B
2	15,800	400 ohms	Ant.	Right	15,800	C
3	15,000	400 ohms	Ant.	Right	15,000	D
4	1,400	200 mmf.	Ant.	Left	1,400	E & F

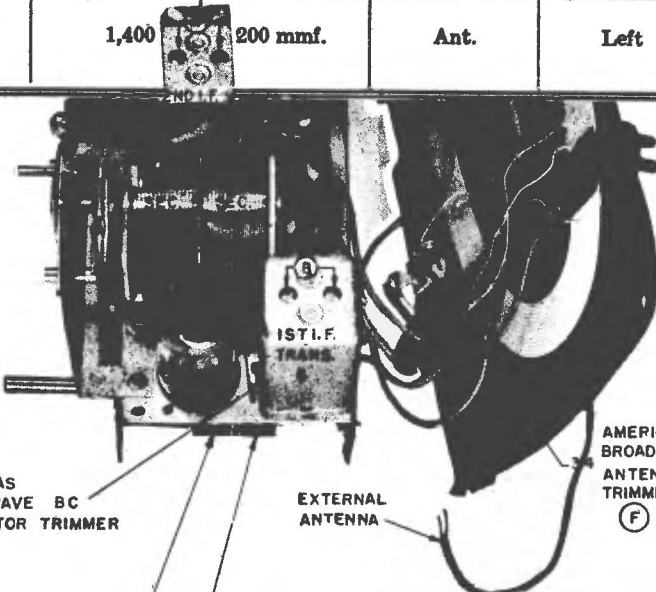

GROSLEY

MODEL: 56TX - L

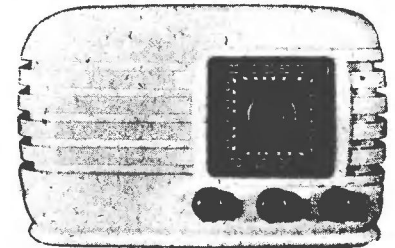

(C) OVERSEAS SHORT WAVE BC OSCILLATOR TRIMMER

(D) OVERSEAS SHORT WAVE ANTENNA TRIMMER

(E) AMERICAN BROADCAST OSCILLATOR TRIMMER

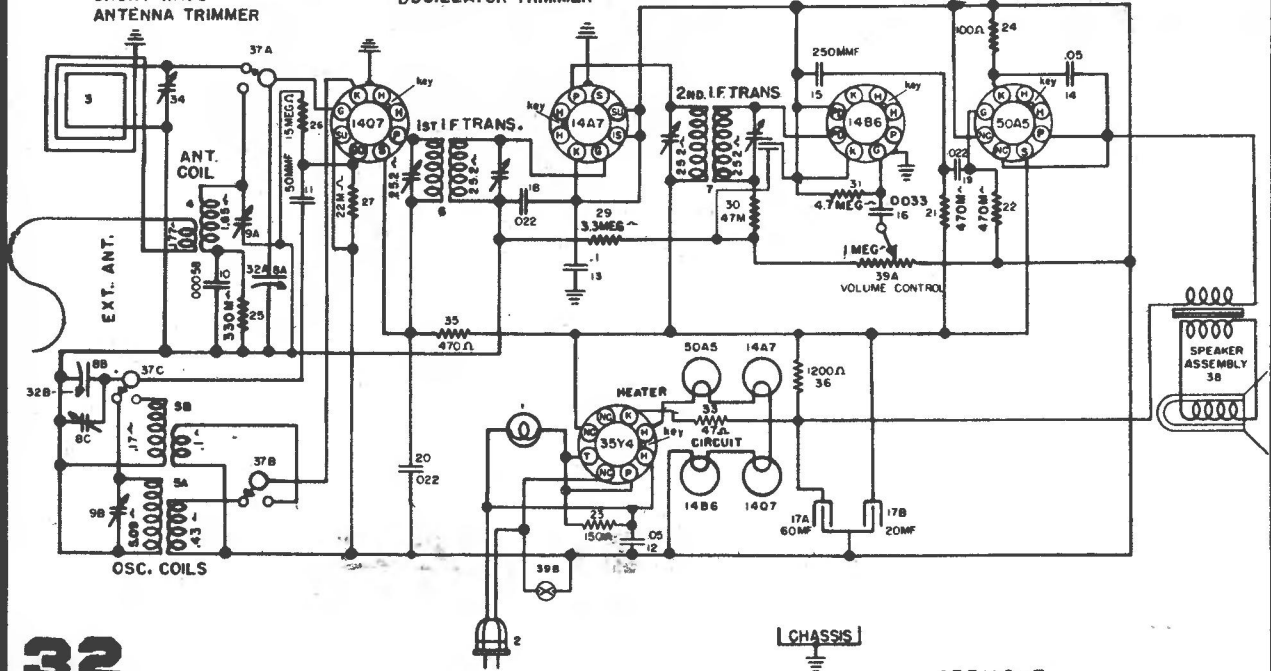

CROSLBY

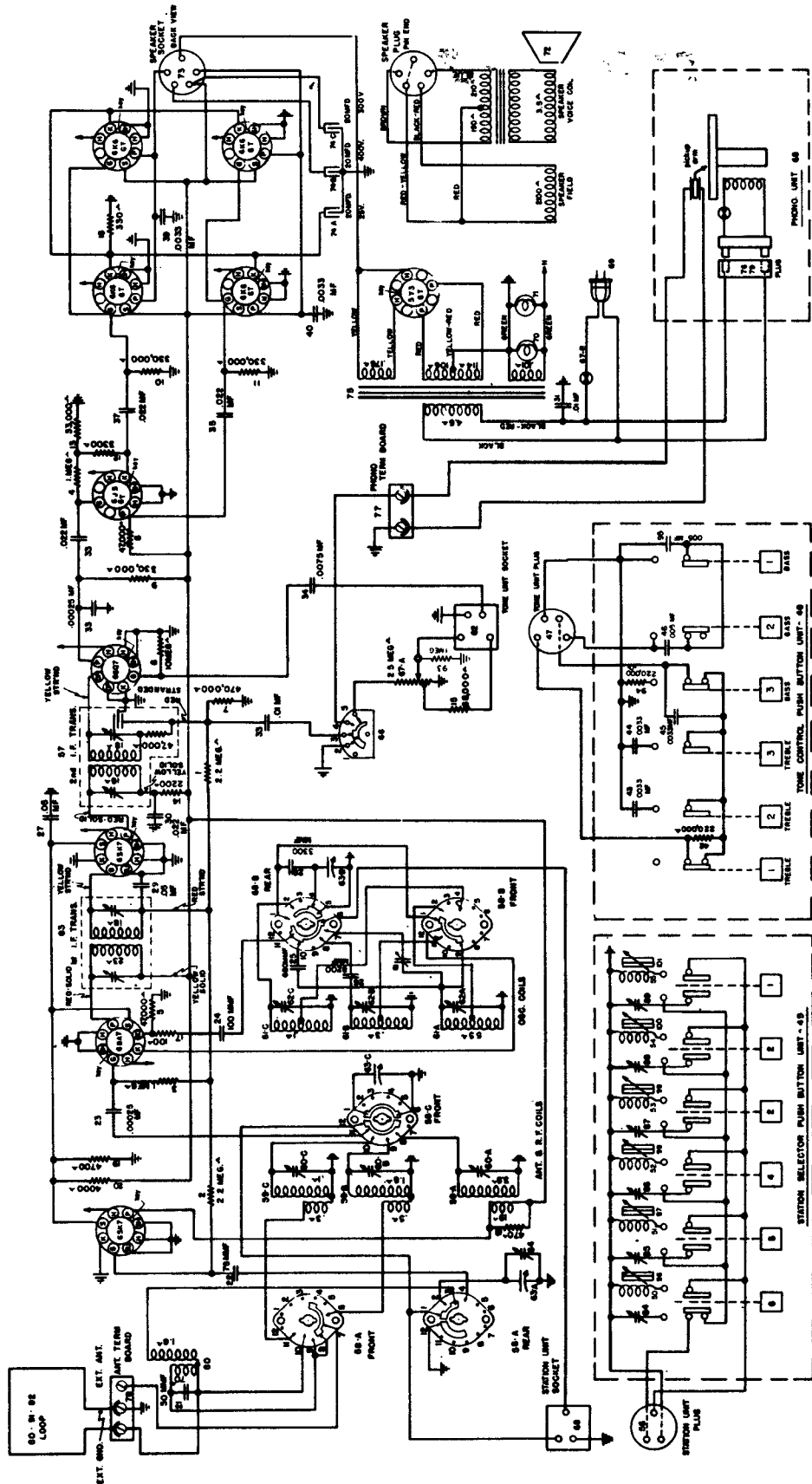

SCHEMATIC DIAGRAM — MODEL 106CP

Alignment information is on the next page.

MANUAL OF 1947 MOST-OFTEN-NEEDED RADIO DIAGRAMS

ALIGNMENT PROCEDURE

MODEL 106CP

Turn the tuning capacitor to the completely closed position against the stop, and set the dial pointer to the reference line at the end of the dial scale.

Set the tone control buttons all the way out.

If the chassis is removed from the cabinet, connect the shorting bar from the volume control (67A) to the coupling capacitor (34) on the tone unit socket.

Connect the output meter across the speaker output transformer connections on the 6K6 tubes.

The r. f. signal input from the signal generator should be connected as indicated in the alignment chart. Connect the low side (ground) of the signal generator to the chassis.

Turn the volume control on full and adjust the signal generator output to produce a noticeable output meter reading.

Alignment adjustment locations are shown in Chassis Top View, at bottom of page.

Alignment Sequence	Signal Generator Output			Position of		Adjust for Maximum Output
	Frequency in kc.	In Series With	To	Band Switch	Tuning Dial	
1	455	200 mmf.	Rear Gang Section	American BC	Fully Open	57 & 83
2	1400	200 mmf.	Ext. Ant.	American BC	1400	62-A
3	1400	200 mmf.	Ext. Ant.	American BC	1400	60--A&6A
4	600	200 mmf.	Ext. Ant.	American BC	600	81
5	6500	400 ohms	Ext. Ant.	Police	Fully Open	62-B
6	6000	400 ohms	Ext. Ant.	Police	6000	60-B
*7	18,300	400 ohms	Ext. Ant.	Overseas	Fully Open	62 C
8	18,000	400 ohms	Ext. Ant.	Overseas	18,000	60-C

The American Broadcast Band must be aligned with the loop antenna connected.

*NOTE: When aligning the short-wave oscillator trimmer (62C), be sure that the circuit is aligned at the correct frequency and not at the image frequency which is 910 kilocycles lower as indicated by the receiving dial. To check: tune in the generator frequency, then increase the generator output and tune in the image frequency. The image frequency should be weaker than the fundamental and audible 910 kilocycles lower on the receiver dial. If the image cannot be tuned in, the oscillator trimmer is adjusted to the wrong peak; i. e., the oscillator trimmer may be adjusted to the image or one of the harmonics instead of the fundamental frequency. The correct peak is the second one heard as the trimmer adjustment screw is opened from the completely closed position.

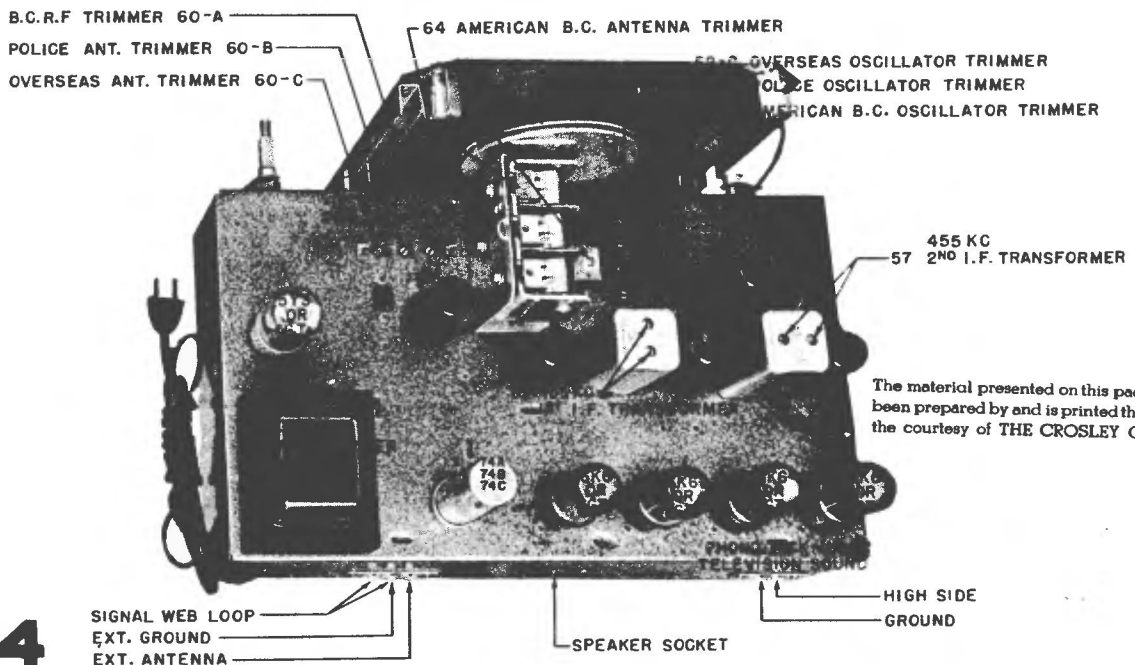

The material presented on this page has been prepared by and is printed through the courtesy of THE CROSLLEY CORP.

MANUAL OF 1947 MOST-OFTEN-NEEDED RADIO DIAGRAMS

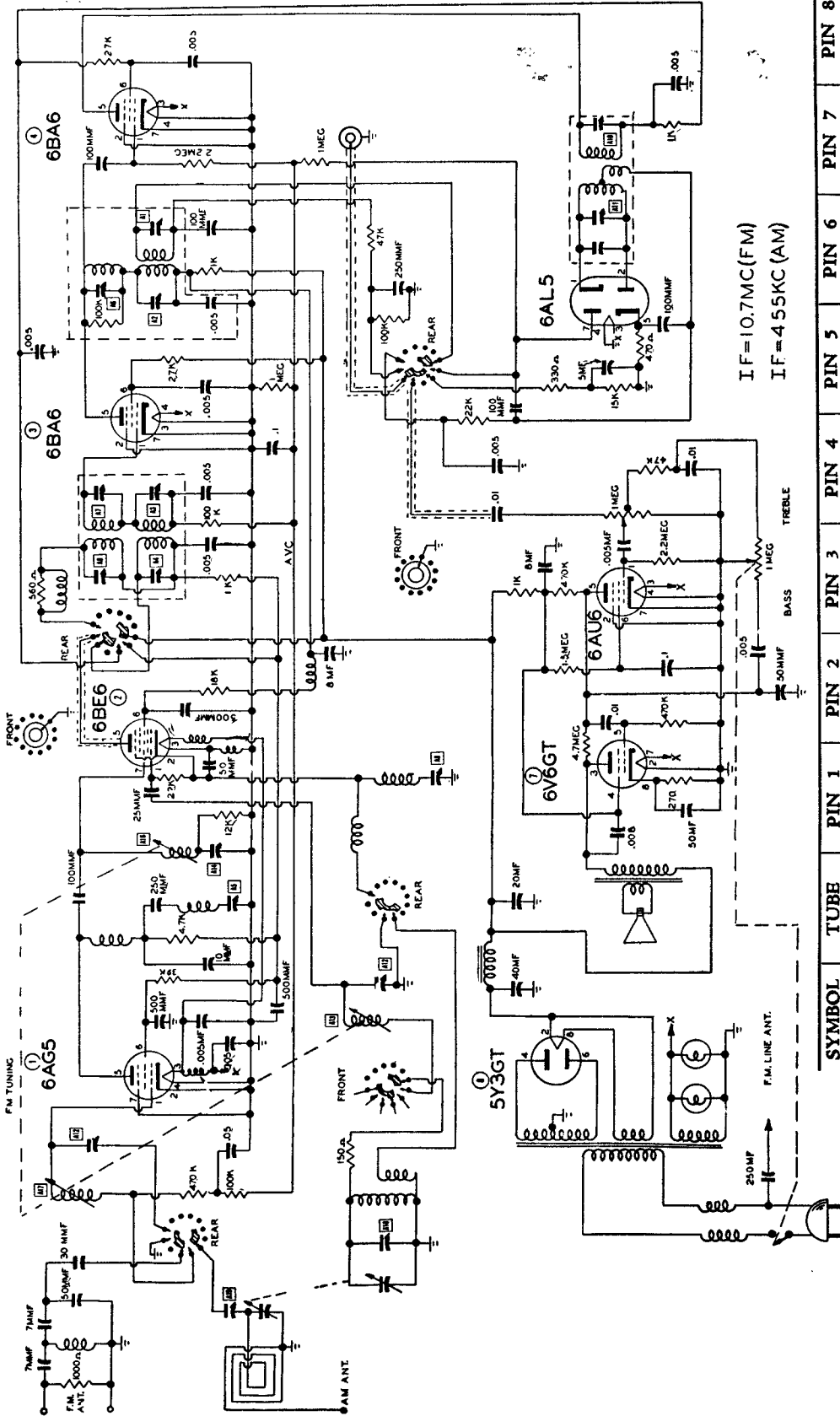

SYMBOL	TUBE	PIN 1	PIN 2	PIN 3	PIN 4	PIN 5	PIN 6	PIN 7	PIN 8
1	6AG5	-0.5 DC	0	6.5 AC	0	225 DC	137 DC	0	
2	6BE6	-0.3 DC	0	0	6.5 AC	270 DC	100 DC	0	
3	6BA6	-0.1 DC	0	0	6.5 AC	260 DC	115 DC	0	
4	6BA6	-0.4 DC	0	6.5 AC	0	0	0	0	
4A	6BA6	-0.3 DC	0	6.5 AC	0	250 DC	110 DC	0	
5	6AL5	0	0	6.5 AC	0	0	0	-0.8 DC	
6	6AU6	-0.8 DC	0	6.5 AC	0	105 DC	32 DC	0	13.5 DC
7	6V6GT	0	0	260 DC	270 DC	0	105 DC	6.5 AC	300 DC
8	5Y3GT	0	300 DC	0	300 AC	0	300 AC	0	300 DC

Emerson Radio
Model 528
Chassis 120038

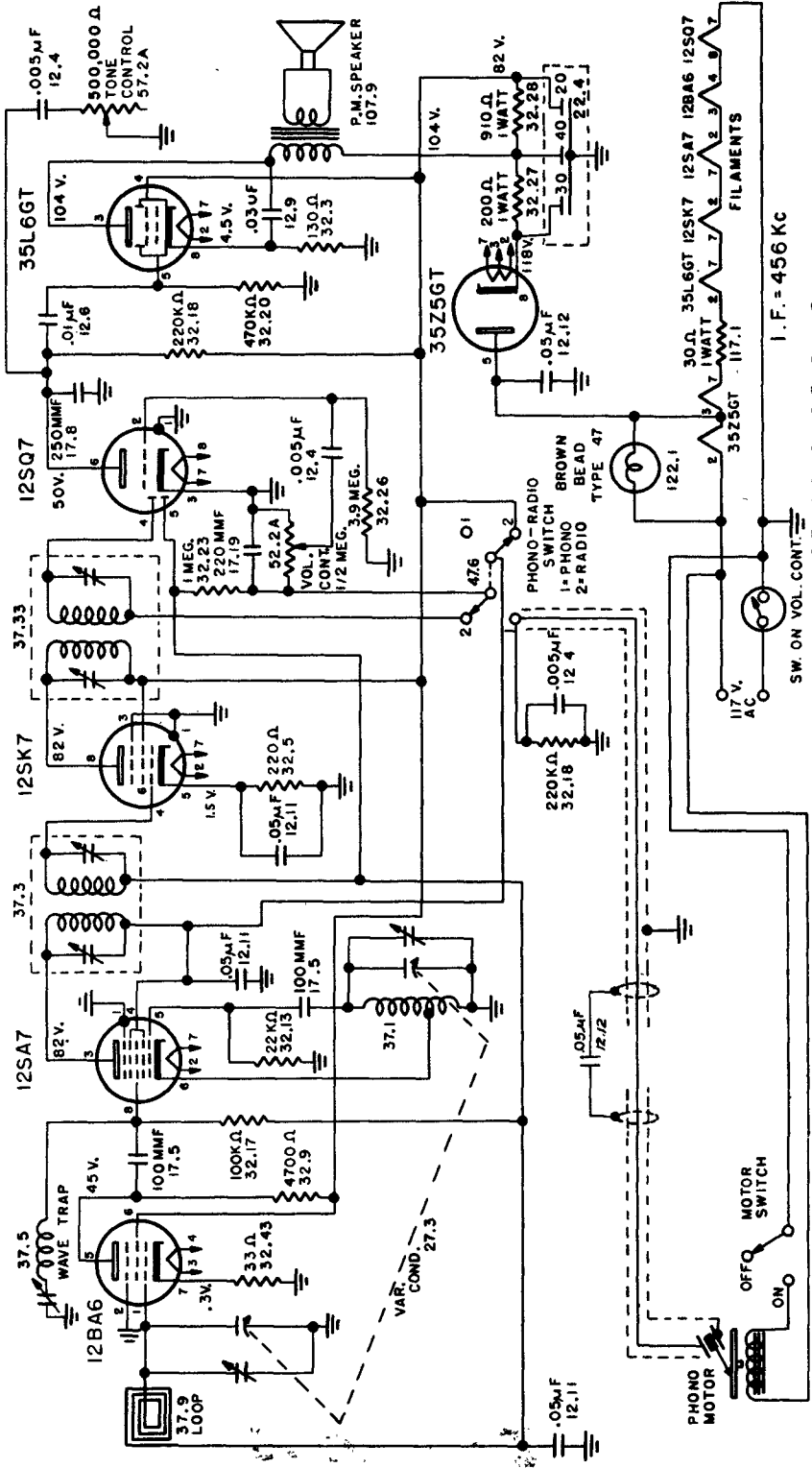

MODEL 637-602
SCHEMATIC
 FADA RADIO & ELECTRIC CO., INC.
 LONG ISLAND CITY, N.Y., U.S.A.

VOLTAGE READINGS TAKEN WITH
 20,000 OHMS PER VOLT METER
 NO SIGNAL CONDITION
 117 VOLT 60 CYCLE LINE
 TUNING RANGE 528-1680 KC

NOTE: K=1000 OHMS | GROUND | CONNECTED WIRES

Power supply 105-125 V 60 cycles A.C. only
 Power consumption 45 Watts Total
 Frequency Range 1680-528 KC
 I.F. Circuits 456 KC

FADA RADIO & ELECTRIC CO., Inc.

MANUAL OF 1947 MOST-OFTEN-NEEDED RADIO DIAGRAMS

Fada Radio Model 1001 ***** Alignment Procedure

Volume Control full on.
 Low range A.C. meter connected across voice coil to indicate output.
 Keep signal generator attenuated so as to maintain 1/2 scale reading on output meter.
 Make certain that dial pointer is exactly on index line (top left side of dial plate) when variable condenser is fully meshed.

Receiver Dial at:	Signal Generator	Dummy Antenna	Connect Signal Generator to:	Refer to Chassis Layout for Location of Trimmers
1 Full Open	Exactly 456 KC	.1 MF	Control Grid 12SA7 Tube Pin No. 8 on 12SA7 Socket	Adjust for Maximum Output T1, T2, T3 & T4
2 Full Open	Exactly 456 KC	.1 MF	Control Grid 12BA6 Tube (R.F.) (Top) Rear Section Variable Condenser	Adjust for Minimum Output T5 Note: On later production this trimmer is eliminated.
3 Full Open	Exactly 1680 KC		Radiating Loop (1/2 meter) 20" from Receiver	Adjust for Maximum Output T6
4 Approx. 1500 KC	Approx. 1500 KC		Radiating Loop (1/2 meter) 20" from Receiver	Adjust for Maximum Output T7
5 Approx. 600 KC	Approx. 600 KC		Radiating Loop (1/2 meter) 20" from Receiver	Check tracking and bend slotted end plate (rear section) of variable if necessary.

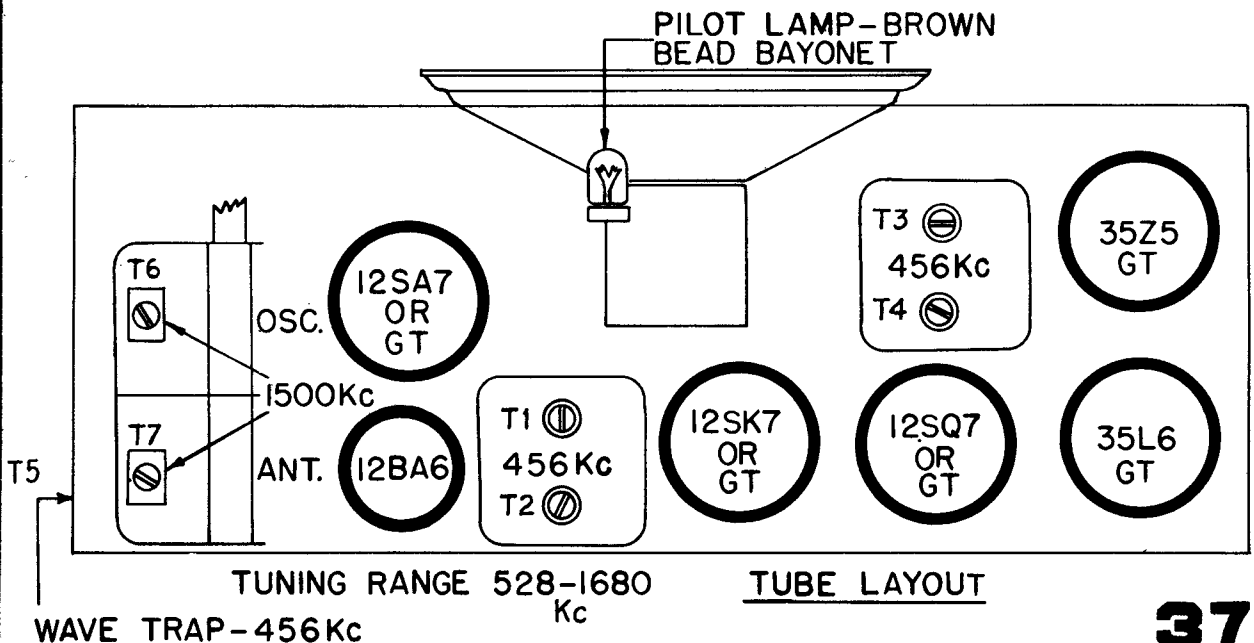

ALL READINGS TAKEN WITH METER HAVING 10 MEGOHMS
INTERNAL RESISTANCE AND TAKEN FROM B-
GAIN PER STAGE READINGS TAKEN WITH 3 VOLTS FIXED NIAS
ALL RESISTANCE READINGS TAKEN WITH VOLUME
CONTROL SWITCH IN "OFF" POSITION

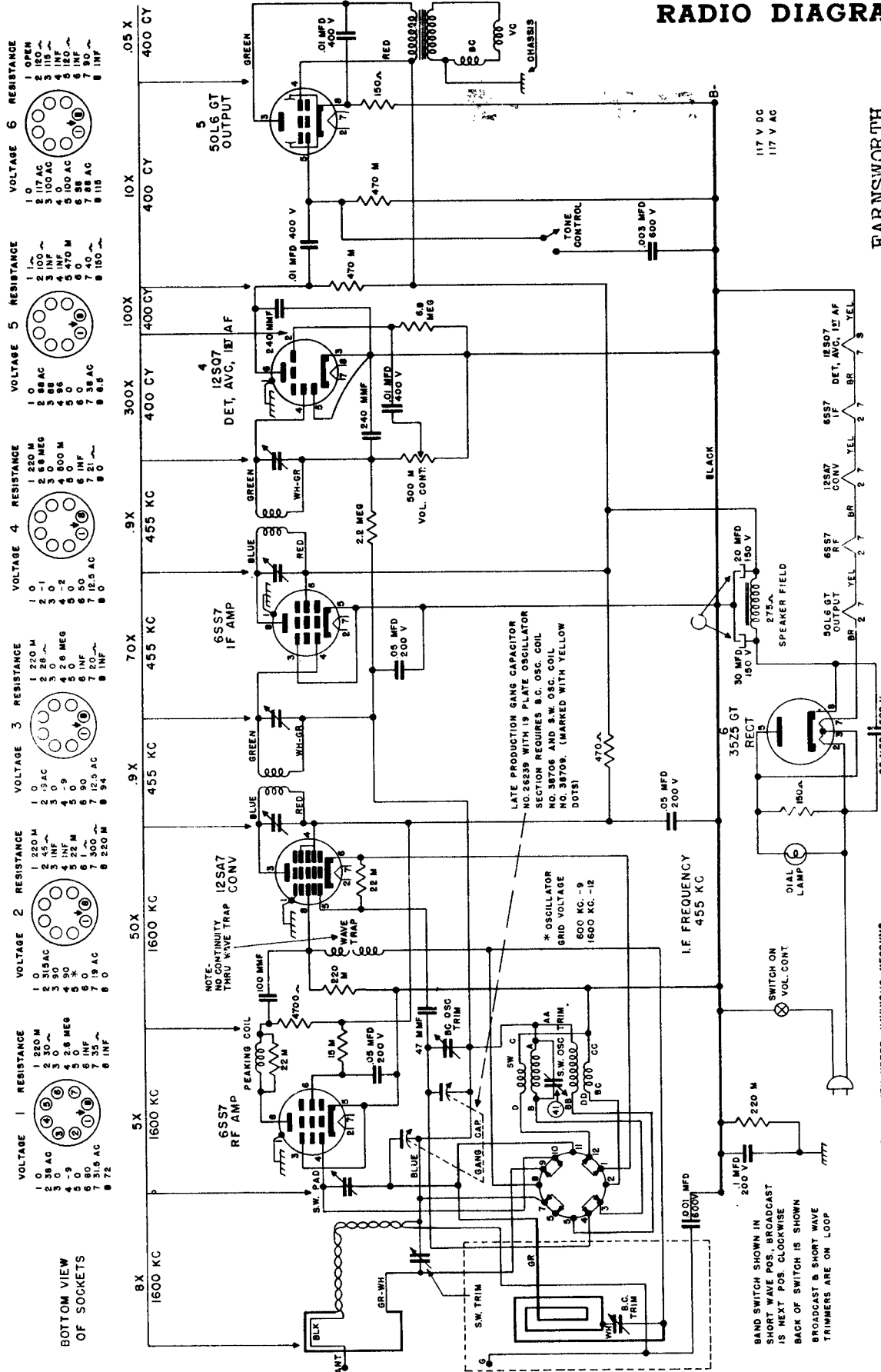

BOTTOM VIEW OF SOCKETS

VOLTAGE	RESISTANCE
1 0	1 220 M
2 38 AC	2 30
3 0	3 30
4 -9	4 2.8 MEG
5 0	5 22 M
6 0	6 10
7 31.5 AC	7 300
8 72	8 220 M

VOLTAGE 1

VOLTAGE	RESISTANCE
1 0	1 220 M
2 31.8 AC	2 45
3 0	3 10
4 -9	4 2.8 MEG
5 0	5 22 M
6 0	6 10
7 19 AC	7 300
8 0	8 220 M

VOLTAGE 2

VOLTAGE	RESISTANCE
1 0	1 220 M
2 31.8 AC	2 45
3 0	3 10
4 -9	4 2.8 MEG
5 0	5 22 M
6 0	6 10
7 12.5 AC	7 20
8 0	8 94

VOLTAGE 3

VOLTAGE	RESISTANCE
1 0	1 220 M
2 1.3 AC	2 28
3 0	3 0
4 -2	4 800 M
5 0	5 0
6 50	6 10
7 12.5 AC	7 21
8 0	8 0

VOLTAGE 4

VOLTAGE	RESISTANCE
1 0	1 220 M
2 0	2 0
3 0	3 0
4 -2	4 800 M
5 0	5 0
6 50	6 10
7 12.5 AC	7 21
8 0	8 0

VOLTAGE 5

VOLTAGE	RESISTANCE
1 0	1 1
2 0	2 0
3 10	3 10
4 86	4 86
5 0	5 0
6 50	6 10
7 0	7 0
8 150	8 150

VOLTAGE 6

VOLTAGE	RESISTANCE
1 OPEN	1 OPEN
2 100 AC	2 100 AC
3 115	3 115
4 0	4 0
5 100 AC	5 100 AC
6 115	6 115
7 0	7 0
8 115	8 115

MANUAL OF 1947 MOST-OFTEN-NEEDED RADIO DIAGRAMS

Farnsworth Models ET-060, ET-061, ET-063, Chassis C-150

EQUIPMENT AND PROCEDURE FOR ALIGNMENT

A Signal Generator calibrated at 455 Kc., 600 Kc., 1000 Kc., 1500 Kc., 15 Mc., 12.5 Mc., and 10 Mc., and an output indicator are required to properly align this receiver. All adjustments should be made with the volume control set for maximum, keeping the signal generator output as low as possible to prevent AVC action and incorrect adjustments.

Connect the low side of the Signal Generator to the chassis through a .1 Mfd. condenser. Connect the high side to antenna lead at rear of set through dummy load of 100 MMF for Broadcast and 400 ohms for Shortwave.

The loop antenna should be placed in approximately the position relative to chassis as when chassis is installed in cabinet.

When aligning the Shortwave Oscillator, use the peak found farthest out from maximum capacity on the oscillator trimmer. Use the peak nearest maximum capacity on the loop trimmer.

TABULATION FOR ALIGNMENT

STEPS	DUMMY ANTENNA	SET GENERATOR AT	SET GANG AT	ADJUST	LOCATED	TO OBTAIN
1	SET VOLUME CONTROL FOR MAXIMUM OUTPUT					
2	100 MMF.	455 Kc.	Minimum Capacity	2nd. I.F. Trimmers	Top of I.F. Transformer	Maximum Output
3				1st. I.F. Trimmers		
4		1500 Kc.	1500 Kc.	B.C. Osc. Trimmer	On Tuning Capacitor	
5		1500 Kc.	1500 Kc.	B.C. Ant. Trimmer	On Loop Antenna	
6		Check Pointer for Calibration at 1000 Kc. and 600 Kc.				
SHORT WAVE BAND						
7	400 Ohms	15 Mc.	Minimum Capacity	S.W. Osc. Trimmer	Chassis Near Rear	Maximum Output
8		12.5 Mc.	12.5 Mc. Rock Gang	S.W. Ant. Trimmer	On Loop	
9	Check	10 Mc.	10 Mc. Rock Gang	S.W. Ant. Padder	Chassis Near Front	

1947 MOST-OFTEN-NEEDED RADIO DIAGRAMS

Federal Telephone & Radio
Models 1030T & 1540T
See next page for
alignment information.

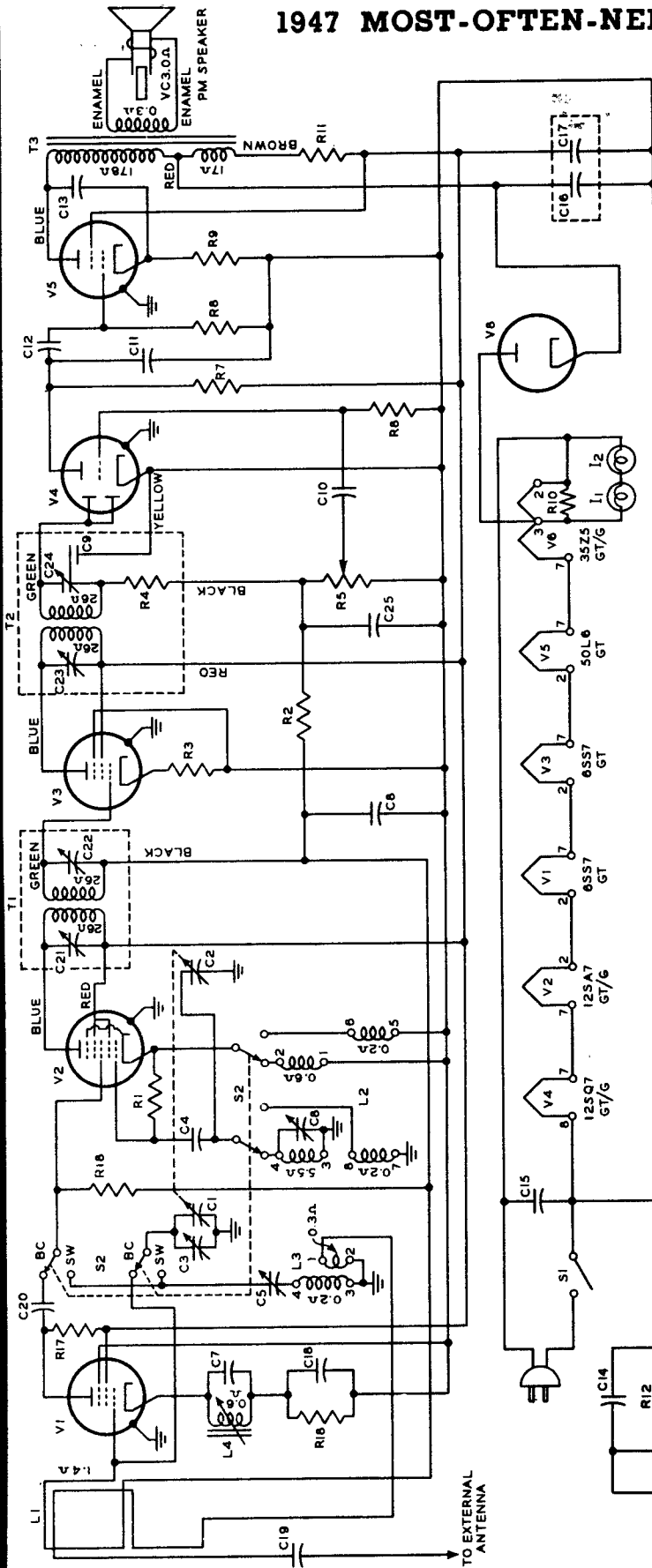

- I1, I2 3.2 v, 160 ma. miniature bayonet base
- L1 200.5 uh \pm 1 uh; dist. cap. 12mmf max.
- L2 2 band pac coil assy.
- L3 SW. RF Coil
- L4 Slug tuned, variation 30-55 uh \pm 10%
- LS1 5* p.m., 3.2 ohm v.c.
- R1 22000 ohms \pm 20%, 1/2 watt carbon
- R2 1.0 megohm \pm 20%, 1/2 watt carbon
- R3 220 ohms \pm 20%, 1/2 watt carbon
- R4 47000 ohms, \pm 20%, 1/2 watt carbon Part of T2
- R5 500,000 ohms taper 50,000 ohms at 1/2 rotation, with "on-off" switch
- R6 10.0 megohm \pm 20%, 1/2 watt carbon
- R7 0.22 megohm \pm 20%, 1/2 watt carbon
- R8 0.47 megohm \pm 20%, 1/2 watt carbon
- R9 170 ohms \pm 10%, 1/2 watt carbon
- R10 270 ohms \pm 10%, 1/2 watt carbon
- R11 1500 ohms \pm 5%, 1 watt carbon
- R12 220,000 ohms \pm 20%, 1/2 watt carbon
- R16 470 ohms \pm 20%, 1/2 watt carbon
- R17 4700 ohms \pm 20%, 1/2 watt carbon
- R18 0.1 megohm \pm 20%, 1/2 watt carbon
- S1 Part of R5
- S2 4 pole, 2 position
- T1 Double tuned, 455 kc.
- T2 Part of R5
- T3 Primary Impedance 2500 ohms, secondary 3.2 ohms.

- C1 2 Gang variable
- C2 Part of C1
- C3 Part of C1
- C4 100 mmfd mica \pm 10% 500 v D.C. working
- C5 Compression trimmer 70-470 mmf (part of C5)
- C6 Compression trimmer 1.6-18 mmf (part of C5)
- C7 3000 mmfd mica \pm 10% 500 v D.C. working
- C8 .05 mfd, tubular, paper, 400 v D.C. working
- C9 .125 mmfd mica, \pm 25% part of T2
- C10 .01 mfd, paper, tubular 400 v D.C. working
- C11 .0015 mfd, mica 20% 500 v C.C. working
- C12 .01 mfd, paper tubular 400 v D.C. working
- C13 .01 mfd, paper tubular 400 v D.C. working
- C14 .2 mfd paper tubular 400 v D.C. working
- C15 .05 mfd paper dielectric 400 v D.C. working
- C16 Electrolytic, 2 section Common cathode
- C17 40 mfd 150 DCWV Sect. 1
- C18 40 mfd 150 DCWV Sect. 2
- C19 Part of C16
- C18 .1 mfd, paper, tubular 400 v D.C. working
- C19 .002 mfd, paper tubular, 600 v D.C. working
- C20 470 mmf. mica \pm 20% 500 v D.C. working
- C21 Part of T1
- C22 Part of T1
- C23 Part of T1
- C24 Part of T2
- C25 100 mmf. mica \pm 10% 500 v D.C. working

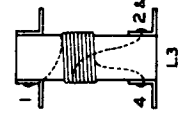
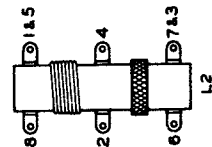

MANUAL OF 1947 MOST-OFTEN-NEEDED RADIO DIAGRAMS

Federal Telephone

MODELS 1030T
AND 1540T

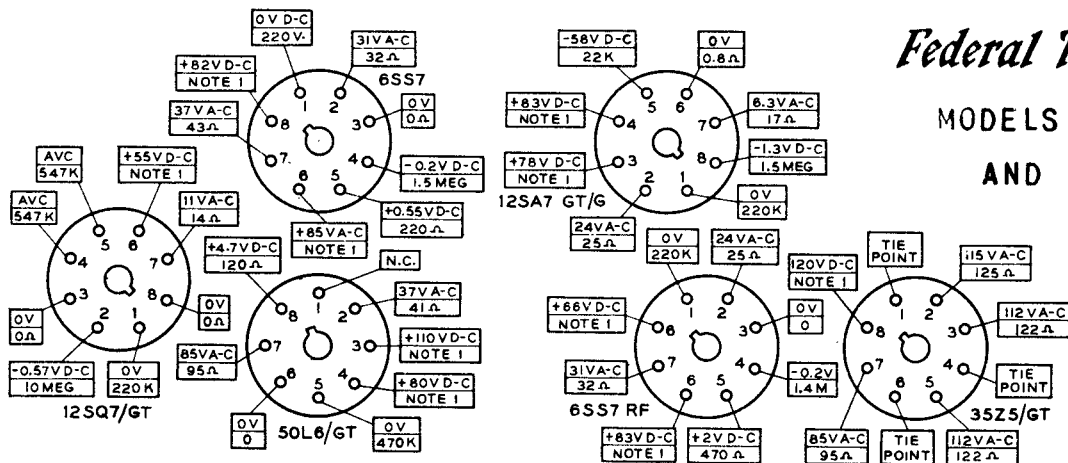

1. Resistance readings at these points will vary since they are in series with the leakage of the electrolytic condensers which is subject to change.
2. All D.C. measurements were made with a meter having a sensitivity of 20,000 ohms per volt. A.C. measurements were made with a 1000 ohms per volt meter.
3. Measured values are from socket pin to circuit ground. (pin 8 of 12SQ7 socket).
4. Tolerances of component values make possible a variation of $\pm 20\%$ in readings

Punch marks are provided on the dial back plate at 600 kc, 1000 kc, 1400 Kc and 1600 Kc for alignment purposes.

With tuning condenser completely open, set dial pointer to 1600 Kc punch mark.

Connect output meter across voice coil terminals on speaker frame.

Connect low side of signal generator lead thru a 0.1 mfd coupling condenser to chassis ground. Connect high side of generator thru proper dummy antenna to the receiver external antenna connection.

Keep signal generator output at lowest practical level and proceed according to table below.

ALIGNMENT CHART

DUMMY ANTENNA	SIGNAL GENERATOR FREQUENCY	BAND SWITCH POSITION	RECEIVER DIAL SETTING	ADJUSTMENT POINTS	OUTPUT METER READING
0.1 MFD.	455 Kc	B.C.	Tuning Condenser Open	C24, C23, C22, C21	Max.
0.1 MFD.	455 Kc	B.C.	Tuning Condenser Open	L4	Min.
200 MMFD.	1600 Kc	B.C.	Tuning Condenser Open	C6	Max.
200 MMFD.	1400 Kc	B.C.	1400 Kc	C3	Max.
200 MMFD.	600 Kc	B.C.	600 Kc	L1	Max.
				(Check, adjust if necessary)	
400 ohms	6 Mc	S.W.	6 Mc	C5	Max.

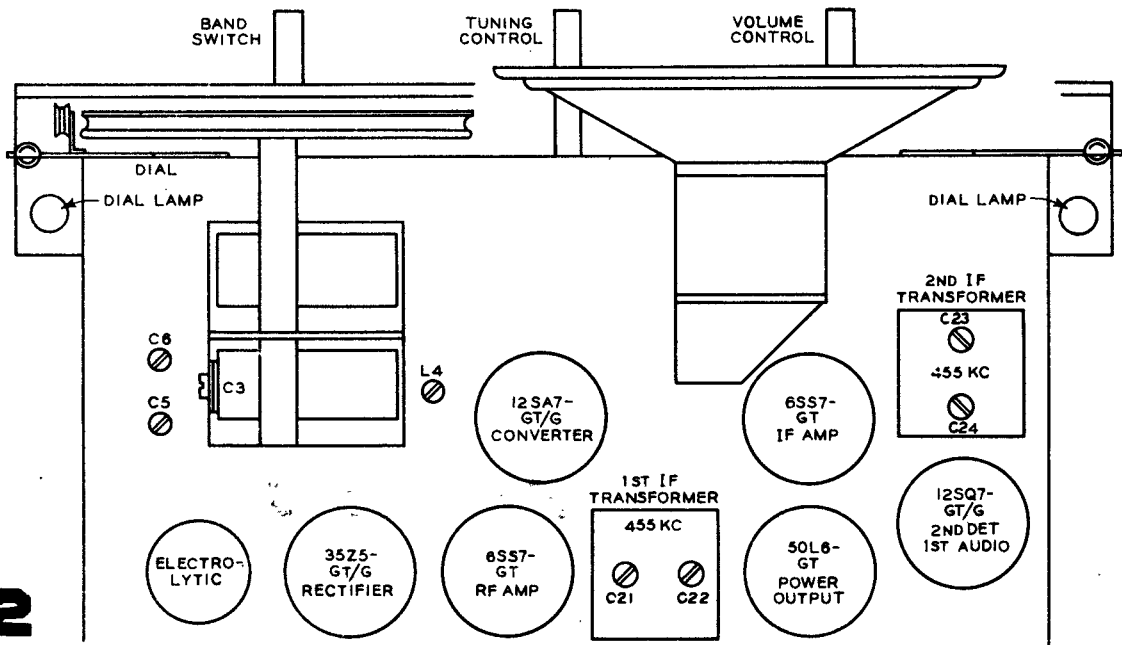

GAROD RADIO

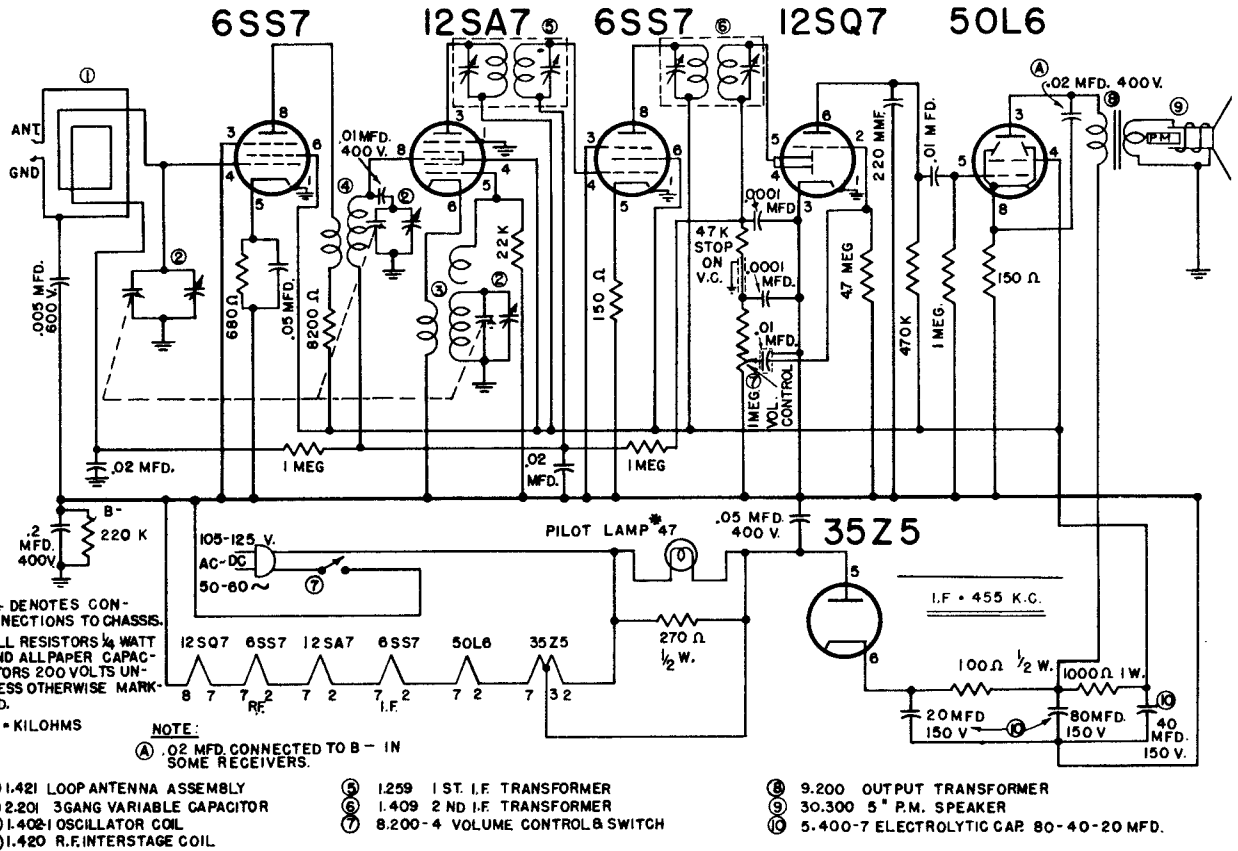

MODEL 6BU-1A

MODEL 45APA

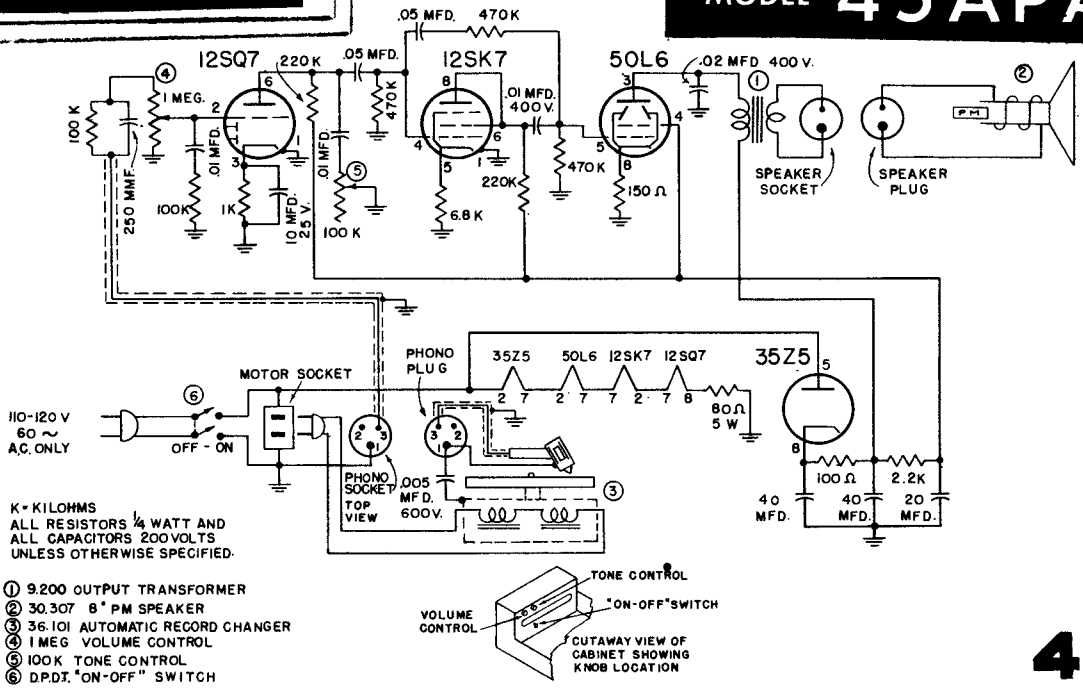

GAROD RADIO



The Sheraton

MODEL **6DPS**

LINE VOLTAGE: This receiver is designed for operation on 105-125 Volts, 50-60 Cycles, Alternating Current (AC) only.

POWER CONSUMPTION INCLUDING RECORD CHANGER: 85 Watts.

TUNING RANGE: Broadcast: 540 to 1650 Kilocycles (180 to 555 Meters)

Short Wave: 5.7 to 18.5 Megacycles (16 to 53 Meters)

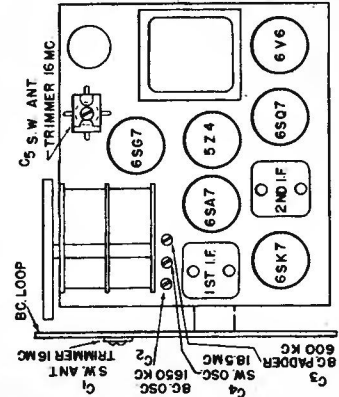
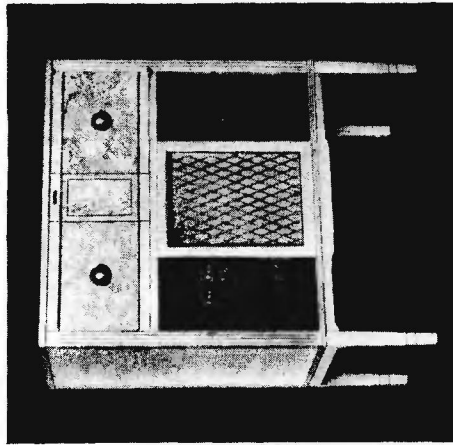

TRIMMER AND TUBE LOCATION DIAGRAM

ALIGNMENT:

Realignment of this receiver should not be attempted unless all other possible causes have been thoroughly investigated. An accurately calibrated signal generator, which will cover the necessary bands, and an output meter for indicating the effect of adjustments are required. During the alignment procedure, all adjustments should be made under the following conditions (refer to Trimmer and Tube Location Diagram below for trimmer location):

- (a) Line voltage as indicated on instruction sheet.
- (b) Volume Control at maximum position.
- (c) Tone Control at extreme left position (brilliant).
- (d) Minimum input from signal generator. This procedure should be adhered to, otherwise adjustments will be broad, due to the action of the automatic volume control.

BROADCAST (Band Switch in extreme left position)

I. F. Adjustment:

(1) Set the signal generator to 455 KC and connect to the lower side of the Loop Antenna Trimmer through a .1 MFD capacitor. Connect the signal generator ground lead to the chassis. Connect a suitable output meter across the speaker voice coil connections. Turn the Variable Capacitor to the extreme clockwise position (minimum capacity).

(2) Adjust the trimmers located at the top of the first and second I. F. Transformers for maximum output as indicated on the output meter.

BC. R. F. Adjustment: It is desirable to align this band on the loop. (1) Couple the signal generator to the receiver loop by means of a two or three turn loop.

(2) With the Variable Capacitor set at the extreme clockwise position (minimum capacity), tune in the 1650 KC signal by means of the broadcast oscillator trimmer (C1).

(3) Set the signal generator to 1500 KC and turn the Tuning Control so that this frequency is indicated on the dial. Adjust the Antenna Trimmer (C2) on the loop for maximum output.

(4) Set the signal generator to 600 KC and turn the Tuning Control so that this frequency is indicated on the dial. Adjust the broadcast oscillator padder capacitor (C3) for maximum response while "rocking" the Variable Capacitor. Recheck the 1500 KC high frequency adjustment trimmer (C2).

SHORT WAVE (Band Switch in the middle position)

(1) Connect the signal generator through a standard short wave dummy antenna to the antenna (green wire) and the ground lead to the chassis of the receiver. Set the signal generator to 18.5 MC.

(2) With the Variable Capacitor set at the extreme clockwise position (minimum capacity), tune in the 18.5 MC signal by means of the S. W. oscillator trimmer (C4).

(3) Set the signal generator to 16 MC and turn the tuning control so that this frequency is indicated on the dial. Adjust the Antenna Trimmer (C5) on the short wave coil for maximum output while rocking the Variable Capacitor from left to right for maximum output. No other adjustments are necessary.

MANUAL OF 1947 MOST-OFTEN-NEEDED RADIO DIAGRAMS

GAROD RADIO MODEL 6DPS

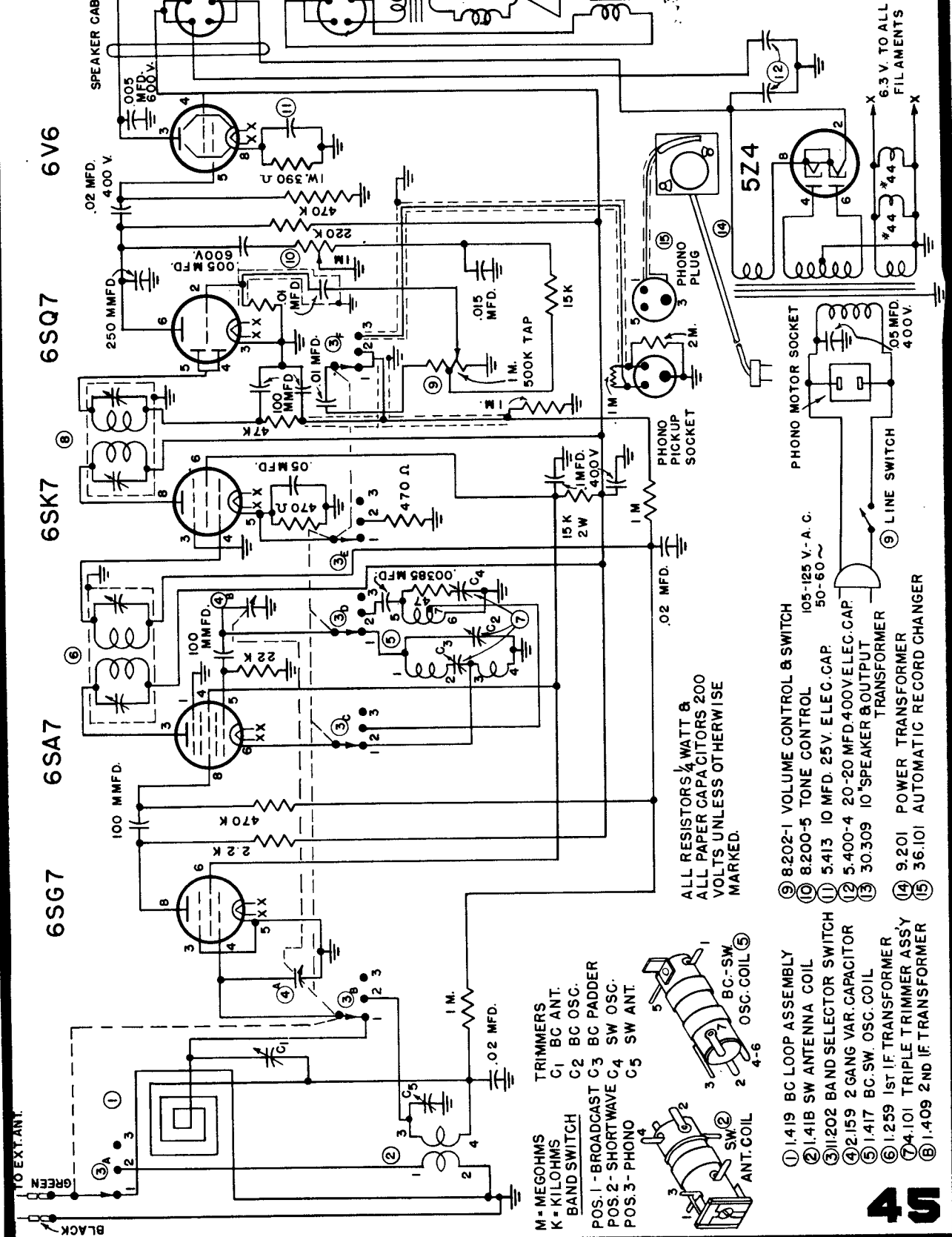

TO EXT. ANT.
GREEN
BLACK

M = MEGOHMS
K = KILOHMS
BAND SWITCH
POS. 1 - BROADCAST C3 BC PADDER
POS. 2 - SHORTWAVE C4 SW OSC.
POS. 3 - PHONO C5 SW ANT.

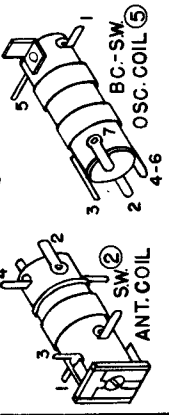

ALL RESISTORS 1/4 WATT &
ALL PAPER CAPACITORS 200
VOLTS UNLESS OTHERWISE
MARKED.

- ① 1.419 BC LOOP ASSEMBLY
- ② 1.41B SW ANTENNA COIL
- ③ 11.202 BAND SELECTOR SWITCH
- ④ 21.159 2 GANG VAR. CAPACITOR
- ⑤ 1.417 BC-SW. OSC. COIL
- ⑥ 1.259 1st IF TRANSFORMER
- ⑦ 4.101 TRIPLE TRIMMER ASSY
- ⑧ 1.409 2nd IF TRANSFORMER

- ⑨ 8.202-1 VOLUME CONTROL & SWITCH
- ⑩ 8.200-5 TONE CONTROL 105-125 V. A. C. 50-60
- ⑪ 5.413 10 MFD. 25V. ELEC. CAP.
- ⑫ 5.400-4 20-20 MFD. 400V. ELEC. CAP.
- ⑬ 30.309 10" SPEAKER & OUTPUT TRANSFORMER
- ⑭ 9.201 POWER TRANSFORMER
- ⑮ 36.101 AUTOMATIC RECORD CHANGER

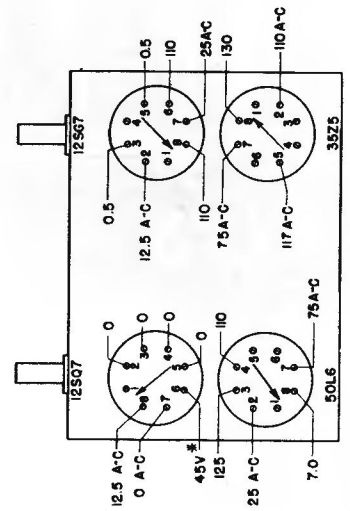
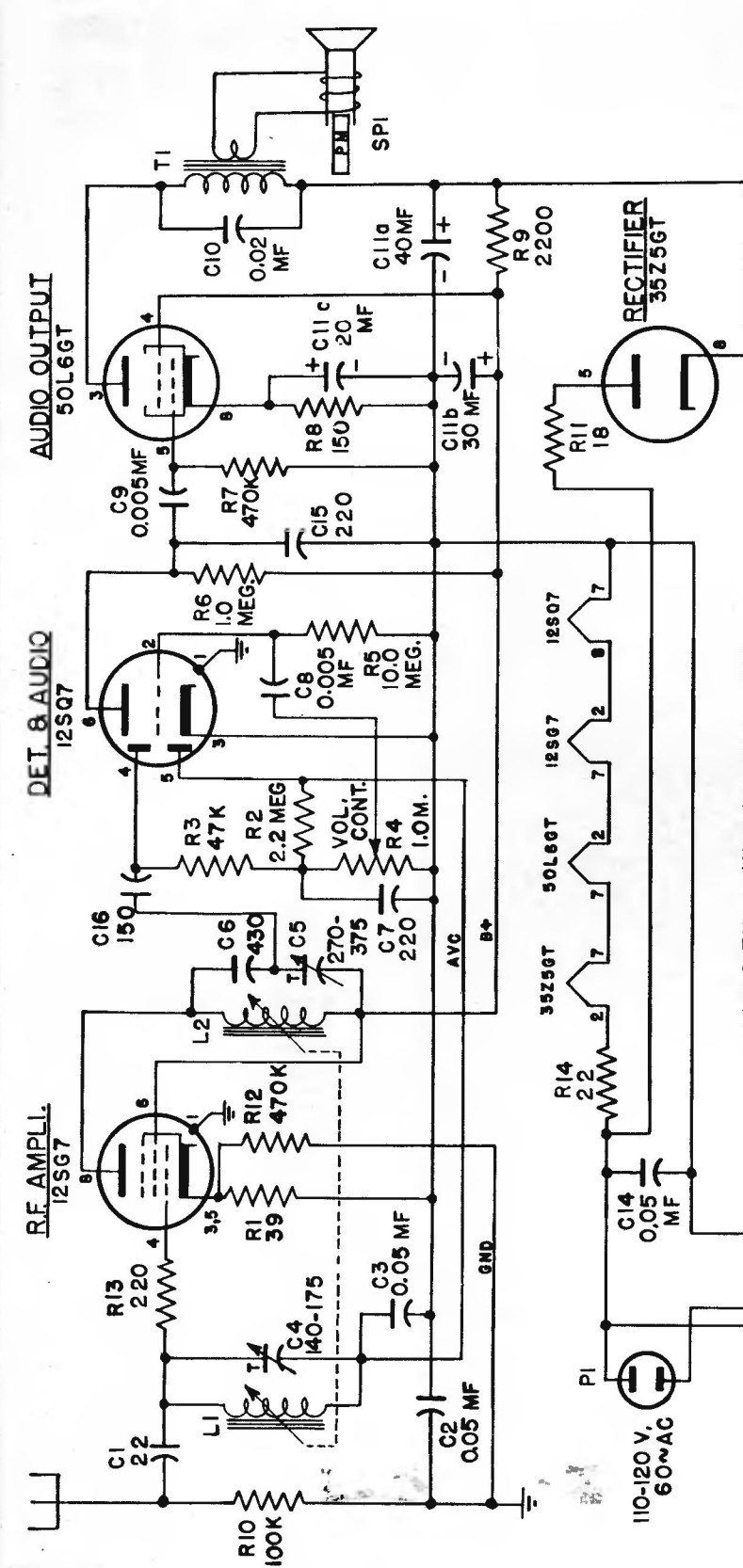

* Measured with 20,000 ohm/volt meter

CAPACITY IN MMF UNLESS NOTED

GENERAL ELECTRIC
RADIO & CLOCK
 SERVICE DATA
 FOR
MODEL 50

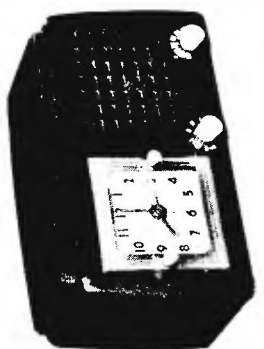
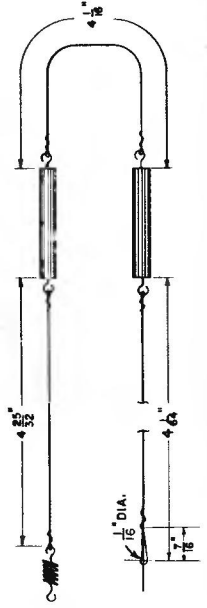

MANUAL OF 1947 MOST-OFTEN-NEEDED RADIO DIAGRAMS

GENERAL ELECTRIC

RADIO SERVICE DATA

FOR MODELS YRB 60-1 AND YRB 60-2

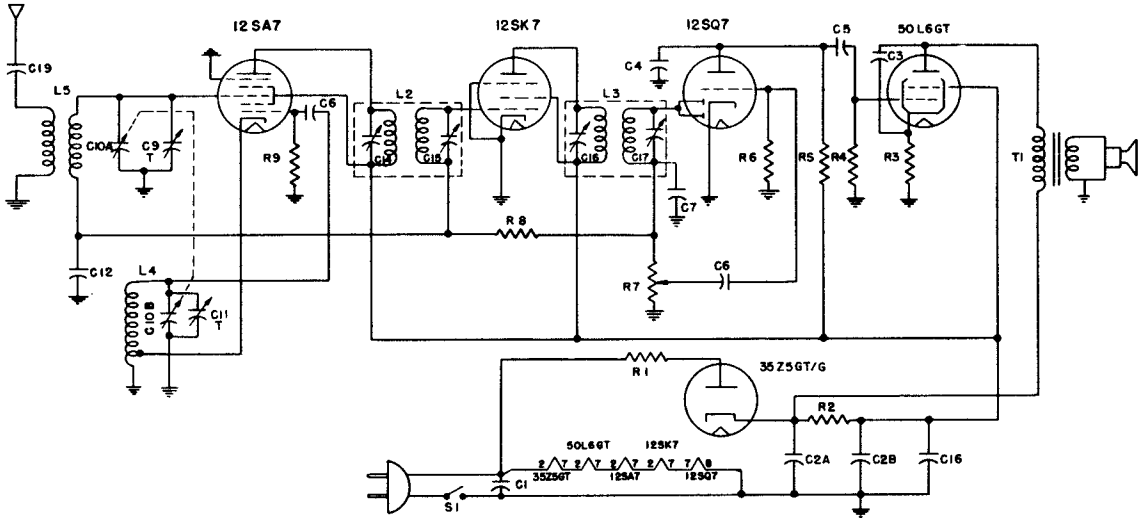
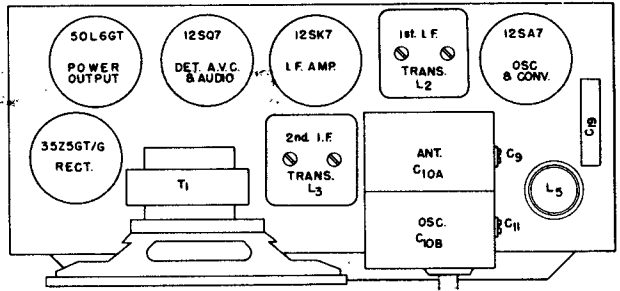

Symbol	Description	Symbol	Description	Symbol	Description
C1	.05 mfd paper capacitor	C10A	Variable condenser, ant. section	R1	18 ohm 1/2 watt carbon resistor
C2A	40 mfd 150 volt electrolytic capacitor	C10B	Variable condenser, osc. section	R2	1500 ohm 2 watt carbon resistor
C2B	40 mfd 150 volt electrolytic capacitor	C11	Oscillator trimmer	R3	150 ohm 1/2 watt carbon resistor
C3	.02 mfd paper capacitor	C12	.05 mfd paper capacitor	R4	470,000 ohm 1/4 watt carbon resistor
C4	330 mmfd mica capacitor	C18	.05 mfd paper capacitor	R5	220,000 ohm 1/4 watt carbon resistor
C5	.01 mfd paper capacitor	C19	.005 mfd paper capacitor	R6	10 megohm 1/4 watt carbon resistor
C6	.005 mfd paper capacitor	L2	1st I.F. transformer	R7	Volume control, 0.5 megohm
C7	330 mmfd mica capacitor	L3	2nd I.F. transformer	R8	2.2 megohm 1/2 watt carbon resistor
C8	47 mmfd mica capacitor	L4	Oscillator coil	R9	22,000 ohm 1/2 watt carbon resistor
C9	Antenna trimmer	L5	Antenna coil	T1	Output transformer

ALIGNMENT PROCEDURE

ALIGNMENT FREQUENCIES

I.F. 455 kc
 R.F. 1725 and 1500 kc
 The location of all trimmers is shown in Fig. 1.

I.F. ALIGNMENT

Connect an output meter across the voice coil. Turn the volume control to maximum. Set test oscillator to 455 kc

and keep the oscillator output as low as a readable meter reading will permit. Apply signal to the converter grid through a .05 mfd capacitor and align progressively the trimmers in the 2nd and 1st I.F. transformer cans.

R.F. ALIGNMENT

Apply the R.F. alignment signals through a standard I.R.E. dummy antenna to the receiver antenna post. With the gang condenser wide open, align the oscillator trimmer (C11) to 1725 kc. Change the generator signal to 1500 kc, tune the receiver to the signal and peak antenna trimmer (C9) for maximum output.

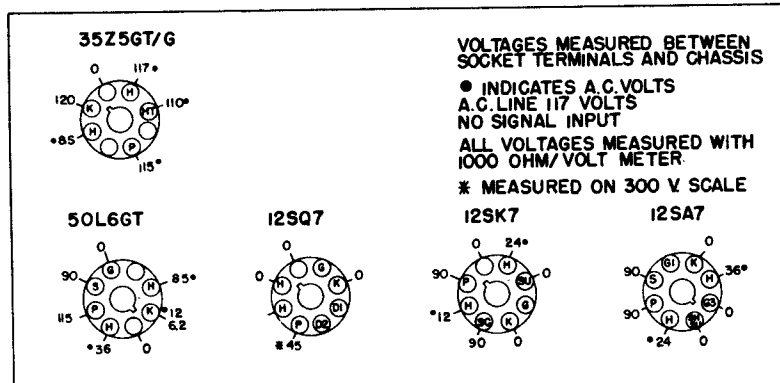

MANUAL OF 1947 MOST-OFTEN-NEEDED RADIO DIAGRAMS

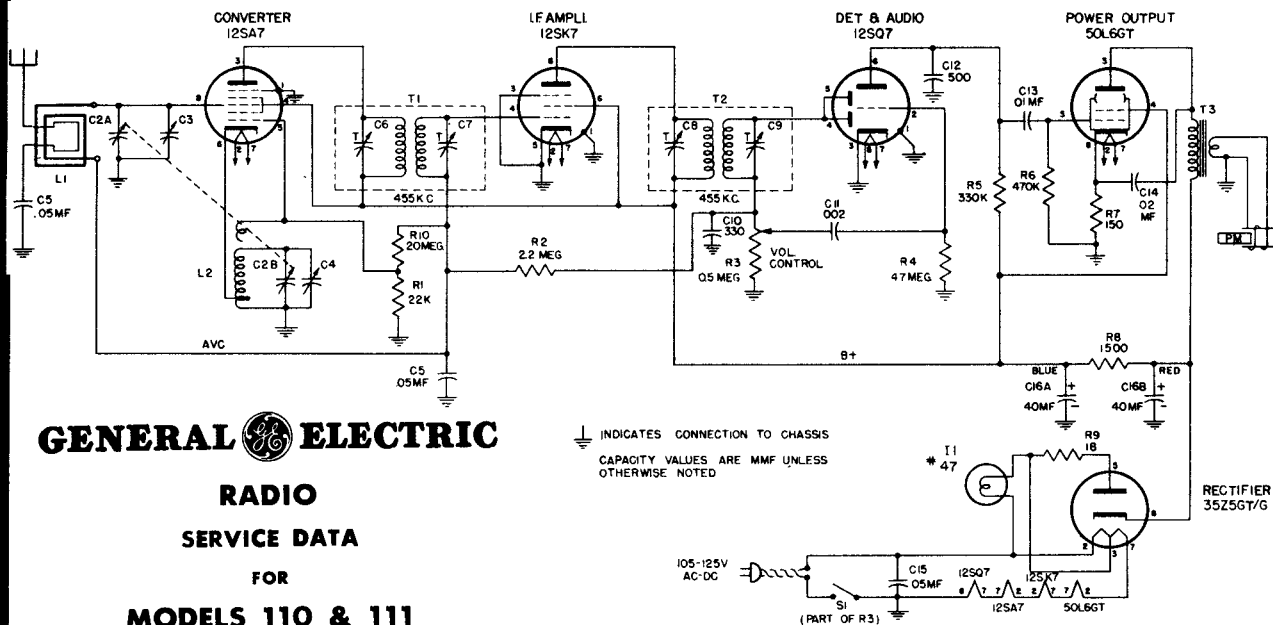

GENERAL ELECTRIC

RADIO

SERVICE DATA

FOR

MODELS 110 & 111

ELECTRICAL CIRCUIT ALIGNMENT

ALIGNMENT FREQUENCIES:

- R-F 1500 kilocycles
- I-F 455 kilocycles

EQUIPMENT REQUIRED:

1. Line isolation transformer.
2. A-c output meter, 1 1/2 volts full scale.
3. Test oscillator with tone modulation.
4. 0.05 mf. paper capacitor.
5. 50 mmf. mica capacitor.
6. Insulated screwdriver.

PROCEDURE—GENERAL. 1. Remove chassis from cabinet. Turn pointer as far counterclockwise as possible. The pointer should set horizontal. If it doesn't, remove the dial window and slip the pointer on its shaft until it is horizontal.

2. Connect the line cord to the line through an isolation 1:1 ratio transformer.
3. Connect output meter across loudspeaker voice coil terminals.
4. Keep radio volume control at maximum and attenuate the test oscillator signal output so that the output meter reading never exceeds 1 volt.
5. For R-F alignment, the Beam-a-scope assembly should be connected and dressed in exactly the same location it would occupy if installed in the cabinet.
6. Connect the capacitor as listed in column 2, between the output "high side" of the test oscillator and the point of input specified.

ALIGNMENT CHART

Step	Connect Test Oscillator to	Test Oscillator Setting	Pointer Setting on Radio	Adjustment for Maximum Output
1	12SQ7 grid in series with 0.05 mf. cap.	455 kc	1500 kc	2nd I-F trans. trimmers
2	12SA7 grid in series with 0.05 mf. cap.	455 kc	1500 kc	1st and 2nd I-F trans. trimmers
3	Ant. post in series with 50 mmf.	1500 kc	1500 kc	C4 (osc.)
4	Ant. post in series with 50 mmf.	1500 kc	1500 kc	C3 (R-F)

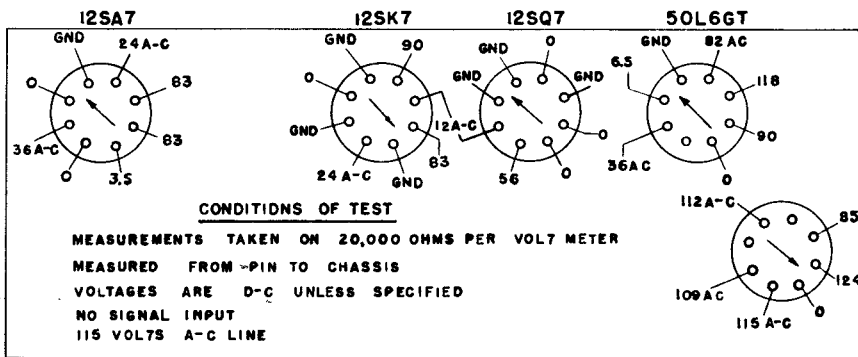
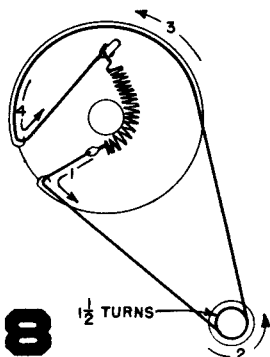
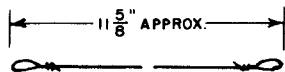
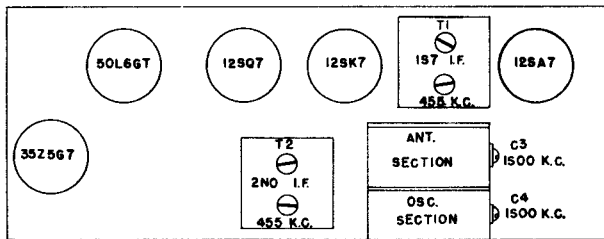

CONDITIONS OF TEST

MEASUREMENTS TAKEN ON 20,000 OHMS PER VOLT METER
 MEASURED FROM -PIN TO CHASSIS
 VOLTAGES ARE D-C UNLESS SPECIFIED
 NO SIGNAL INPUT
 115 VOLTS A-C LINE

BOTTOM VIEW OF CHASSIS

35Z56T

MANUAL OF MOST-OFTEN-NEEDED RADIO DIAGRAMS

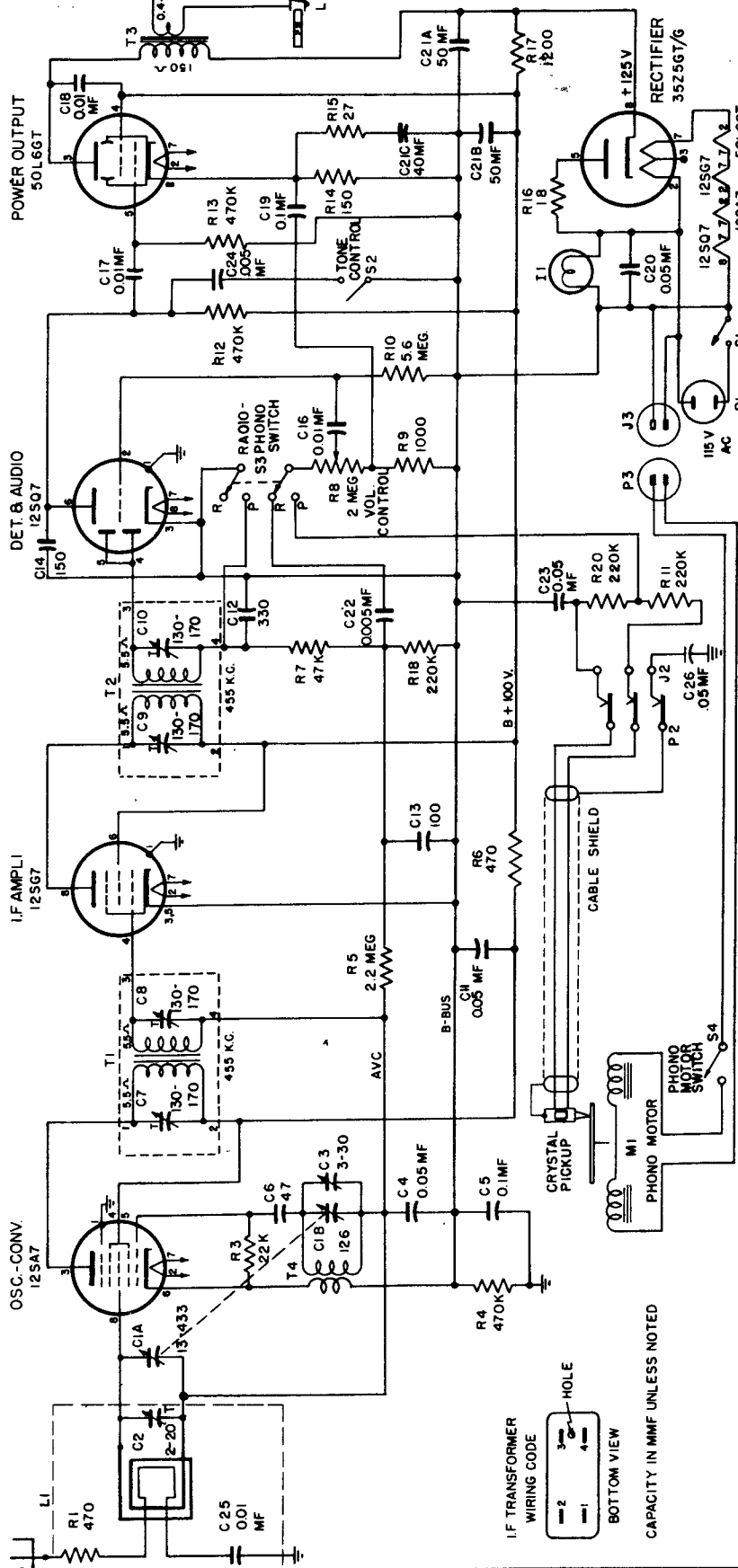

VIEW FROM BOTTOM OF CHASSIS

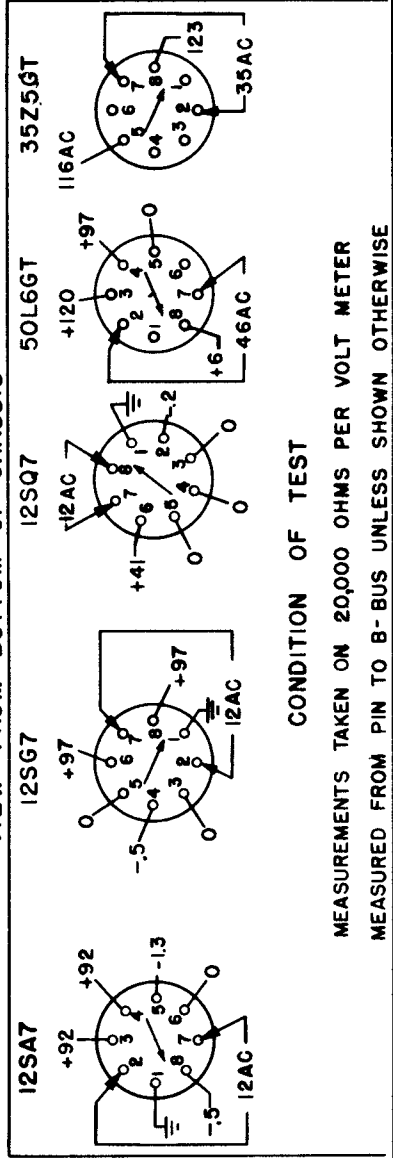

CONDITION OF TEST

MEASUREMENTS TAKEN ON 20,000 OHMS PER VOLT METER
MEASURED FROM PIN TO B-BUS UNLESS SHOWN OTHERWISE

GENERAL ELECTRIC
RADIO-PHONOGRAPH
SERVICE DATA
FOR
MODEL 106

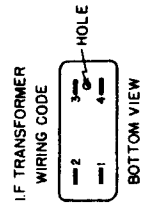

CAPACITY IN MMF UNLESS NOTED

MANUAL OF 1947 MOST-OFTEN-NEEDED RADIO DIAGRAMS

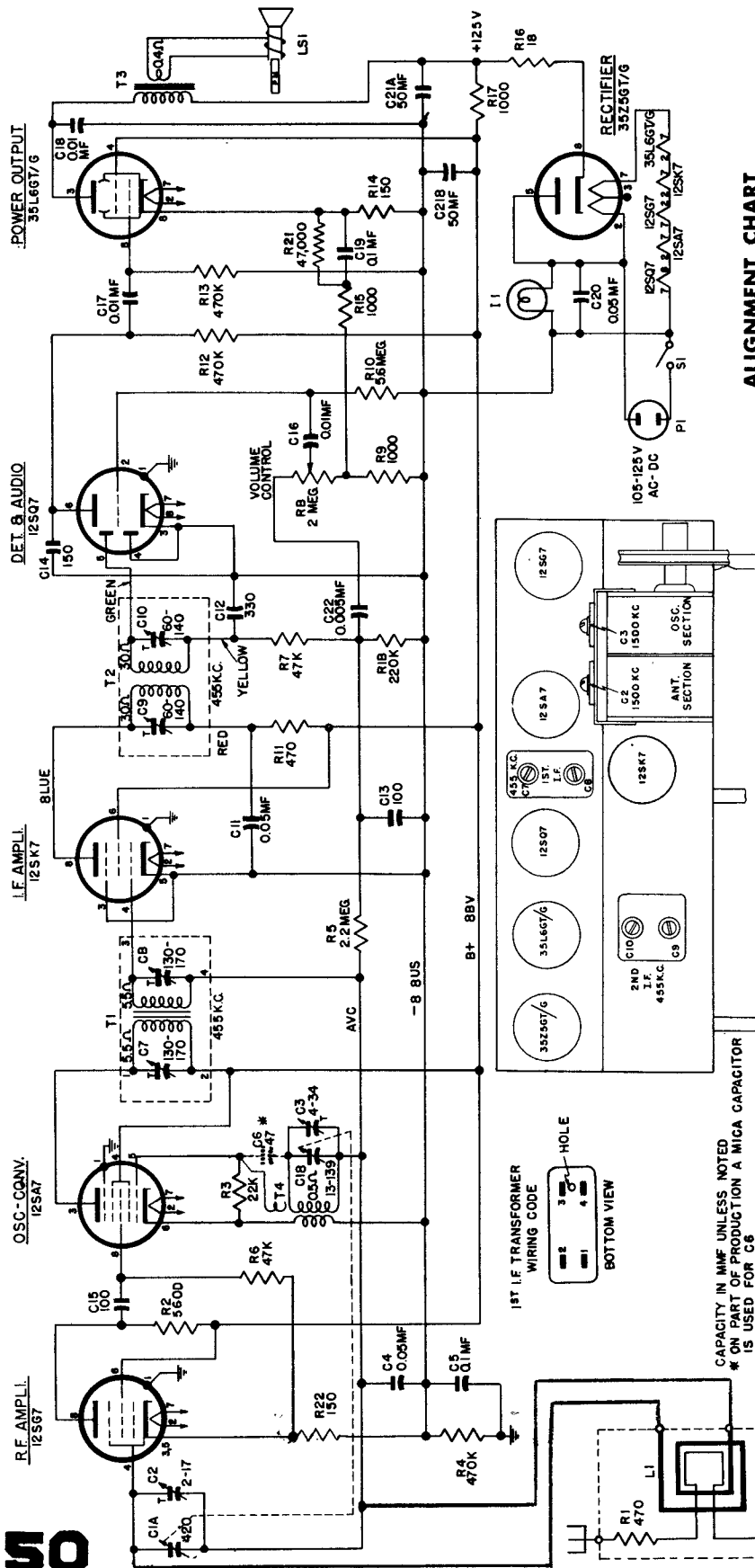

ALIGNMENT CHART

Connect Test Oscillator to	Test Osc. Setting	Pointer Setting on Radio	Adjustment for Maximum Output
12SK7 grid in series with 0.05 mf cap.	455 kc	1500 kc	2nd I-F Trans. Trimmers
12SA7 grid in series with 0.05 mf cap.	455 kc	1500 kc	1st and 2nd I-F Trans. Trimmers
Ant. Post in series with 50 mmf	1500 kc	1500 kc	C3 (Osc.)
Ant. Post in series with 50 mmf	1500 kc	1500 kc	C2 (R-F)

- Turn dial scale pointer as far counterclockwise as possible. The pointer should coincide with the first marking at the left of the scale. If it doesn't, remove chassis and slip pointer on shaft until the pointer is under reference mark when chassis is bolted in place.
- For i-f and r-f alignments, the output meter is connected across the loudspeaker voice coil terminals.
- Keep radio volume control at maximum and attenuate test oscillator signal output so that the output meter reading never exceeds 1.4 volts.
- The chassis must be removed from the cabinet during I-F alignment. For R-F alignment bolt the chassis in the cabinet securely.
- Connect the capacitor as listed in column 2, between the output "High Side" of test oscillator and the point of input specified.

CAPACITY IN MMF UNLESS NOTED
* ON PART OF PRODUCTION A MICA CAPACITOR IS USED FOR C6

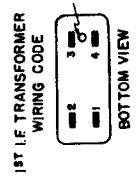

GENERAL ELECTRIC

MODELS 200, 203 & 205

MANUAL OF 1947 MOST-OFTEN-NEEDED RADIO DIAGRAMS

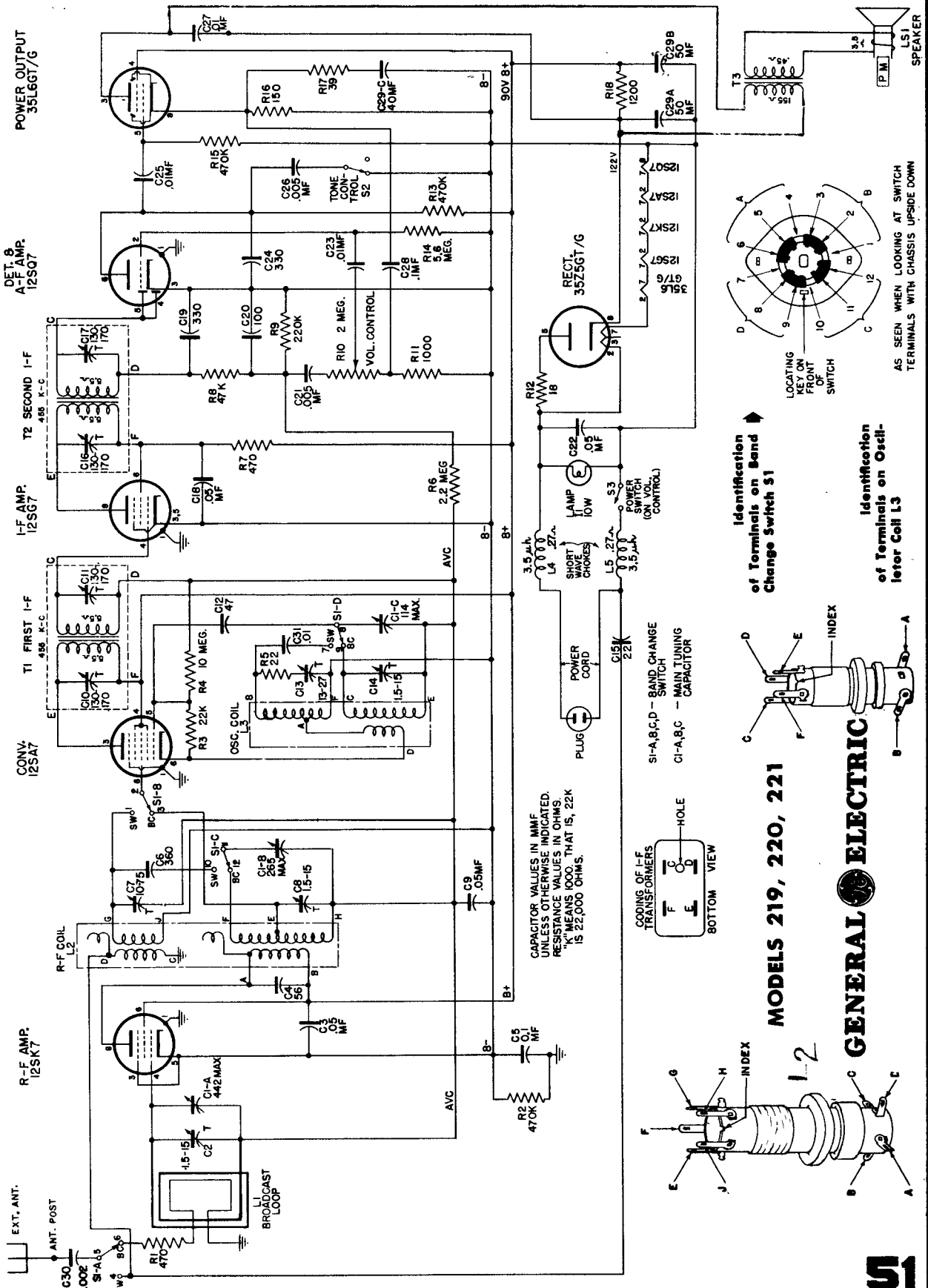

MODELS 219, 220, 221

GENERAL ELECTRIC

MANUAL OF 1947 MOST-OFTEN-NEEDED RADIO DIAGRAMS

GENERAL ELECTRIC

RADIO

TWO-BAND A-C-D-C SUPERHETERODYNE SERVICE DATA

for

MODELS 219, 220, 221

ALIGNMENT

Equipment Needed.

- Signal Generator, modulated 30% with 400 cycles.
- One—60 mmf. capacitor
- One—.05 mf. capacitor
- One—400-ohm resistor
- One—output meter
- One—insulated screw driver.

General.

For a complete alignment, the i-f should be aligned before the r-f.

The i-f sections may be aligned with the chassis removed from the cabinet, but for the final r-f alignment the chassis should be in place, in the cabinet.

Fig. 3 identifies and locates all trimmers.

Be sure the radio has been "on" for at least 10 minutes before making any alignment adjustments.

In order to be sure of frequency stability in the signal generator, follow the manufacturer's recommended procedure for use.

When making connections to the signal generator, avoid any ground connections to the radio unless an isolation transformer is used in the power line.

I-F Alignment.

1. Remove chassis from cabinet.
2. Connect output meter across the speaker voice coil.
3. Set volume control for maximum.
4. Connect output terminal of signal generator through a .05 mf. capacitor to pin 4 of the 12SG7 (i-f amplifier) tube.
5. Set signal generator frequency to 455 kc.
6. Set dial pointer on radio to approximately 1500 kc.
7. Peak second i-f trimmers, C16 and C17, for maximum output.
8. It is important to keep the output reading under 1 1/4 volts by reducing the input or gain control so as to avoid spurious results due to a.v.c. action.

9. Disconnect signal generator from 12SG7 and connect (through .05 mf. capacitor) to pin eight of the 12SA7 converter.
10. Keeping output below 1 1/4 volts as before, peak the first i-f trimmers, C10 and C11, for maximum output.
11. Check second and first i-f trimmer adjustments.

Broadcast R-F Alignment.

When making the following alignment, the Beam-a-Scope (loop antenna) must be mounted to the chassis, and the chassis must be installed in the cabinet. All trimmer adjusting screws are available through the hole in the loop antenna frame.

1. Connect the output of the signal generator through a 60 mmf. capacitor, to the radio antenna post.
2. Set the signal generator and dial pointer to 1500 kc.
3. Adjust C14, C8, and C2 for maximum output. If two peaks are obtained when adjusting C14, the correct point is the one with the trimmer plates the furthest apart.

Shortwave R-F Alignment.

1. Set Band Change switch to SW position.
2. Set dial pointer and signal generator to 9.5 mc.
3. Remove chassis carefully, so as not to disturb the setting of the dial pointer.
4. Connect the output of the signal generator through a .05 mf. capacitor to pin eight of the 12SA7 converter tube.
5. Adjust C13 (under the chassis) for maximum output. Two points of maximum output may be obtained. The correct point is the one with the trimmer plates closest together.
6. Remove the signal generator connection, and connect its output through a 400-ohm resistor to the radio antenna post. Peak C7 for maximum output while rocking-in the main tuning condenser.
7. Replace the chassis in the cabinet, and check the setting of C7.

STAGE GAINS AND VOLTAGE CHECKS

The following information will be useful to servicemen equipped with vacuum tube voltmeters or similar voltage measuring instruments. The stage gain values listed may have a tolerance of 20%.

Stage Gains.

- (1) Antenna terminal* to pin 4 of 12SK7... 4 @ 1000 kc
- (2) Pin 4 of 12SK7† to pin 8 of 12SA7... 10 @ 1000 kc
- (3) Pin 8 of 12SA7† to pin 4 of 12SG7... 35 @ 455 kc
- (4) Pin 4 of 12SG7† to pins 4 or 5 of 12SQ7... 100 @ 455 kc

* Connect to signal generator output through a 60 mmf. capacitor.

† Connect to signal generator output through a .05 mf. capacitor.

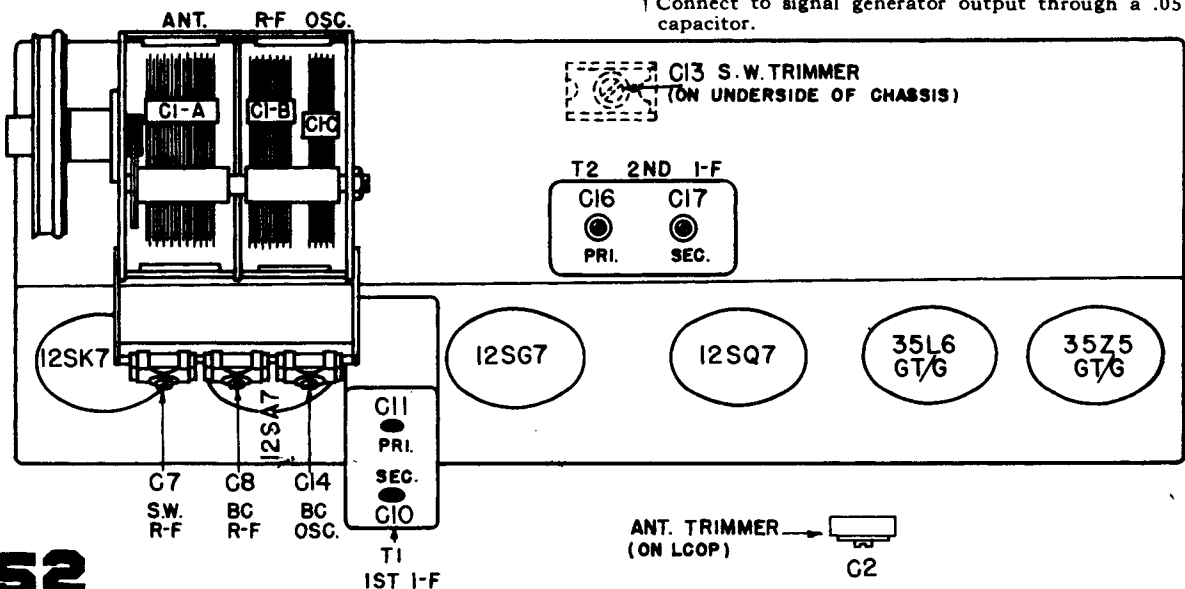

MANUAL OF 1947 MOST-OFTEN-NEEDED RADIO DIAGRAMS

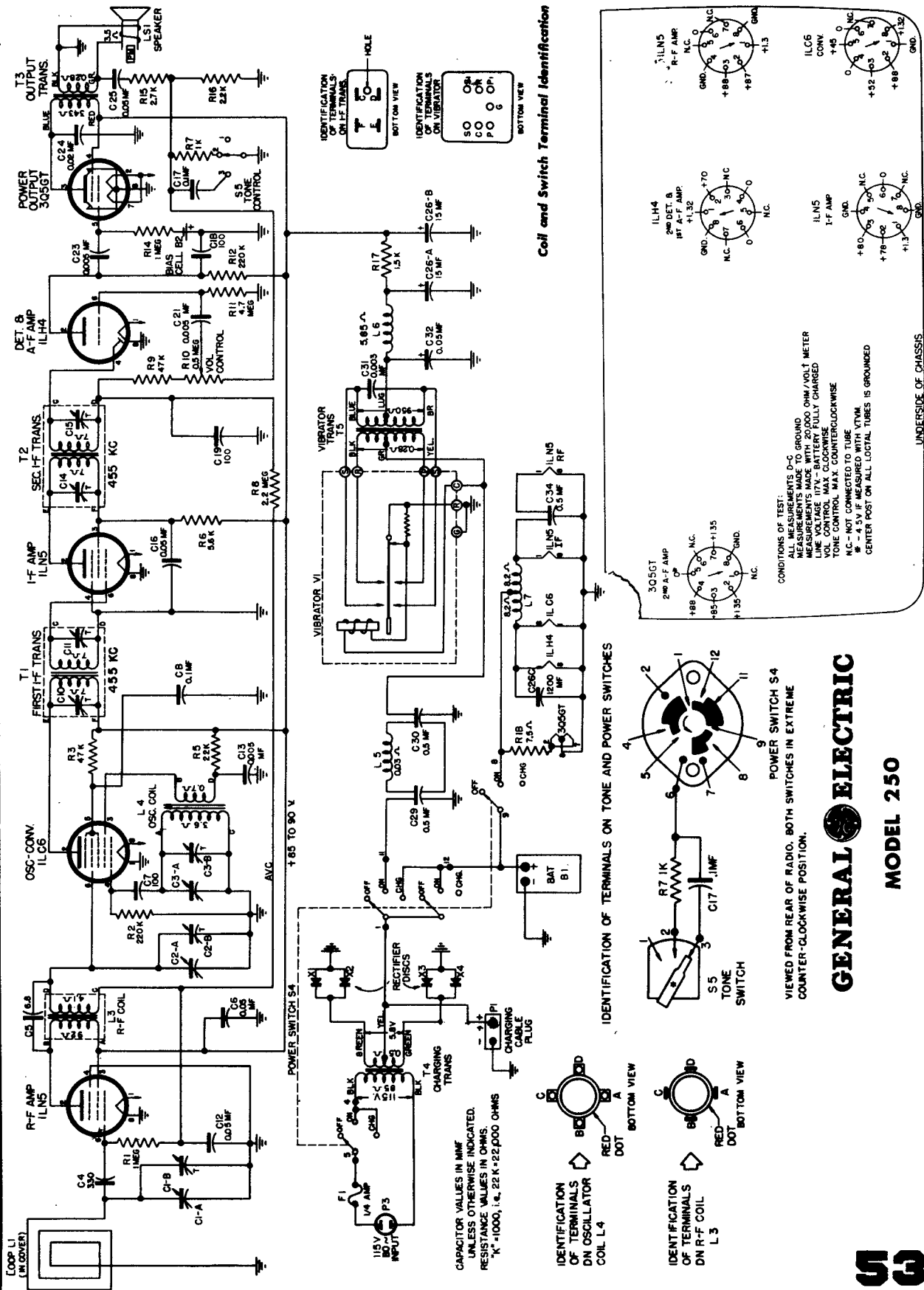

CAPACITOR VALUES IN MMF UNLESS OTHERWISE INDICATED.
 RESISTANCE VALUES IN OHMS.
 "K" - 1000, i.e., 22 K = 22,000 OHMS

IDENTIFICATION OF TERMINALS ON OSCILLATOR COIL L4

IDENTIFICATION OF TERMINALS ON R-F COIL L3

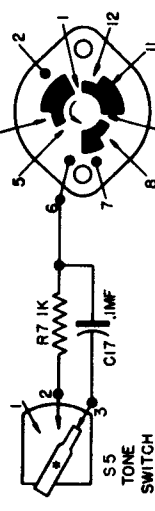
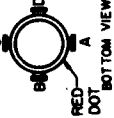

VIEWED FROM REAR OF RADIO. BOTH SWITCHES IN EXTREME COUNTER-CLOCKWISE POSITION.

Coil and Switch Terminal Identification

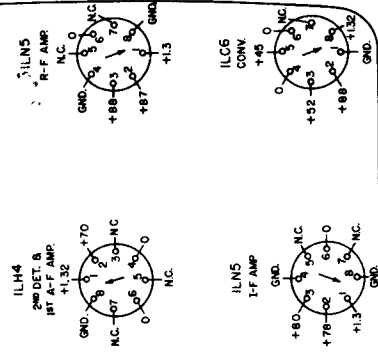
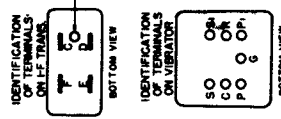

UNDERSIDE OF CHASSIS

MANUAL OF 1947 MOST-OFTEN-NEEDED RADIO DIAGRAMS

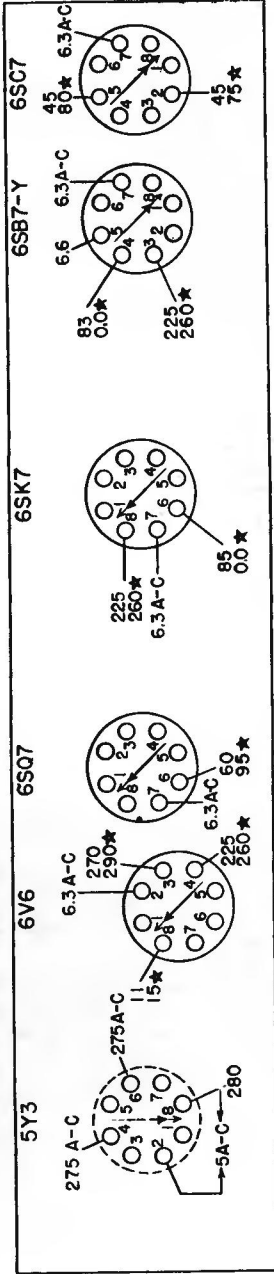
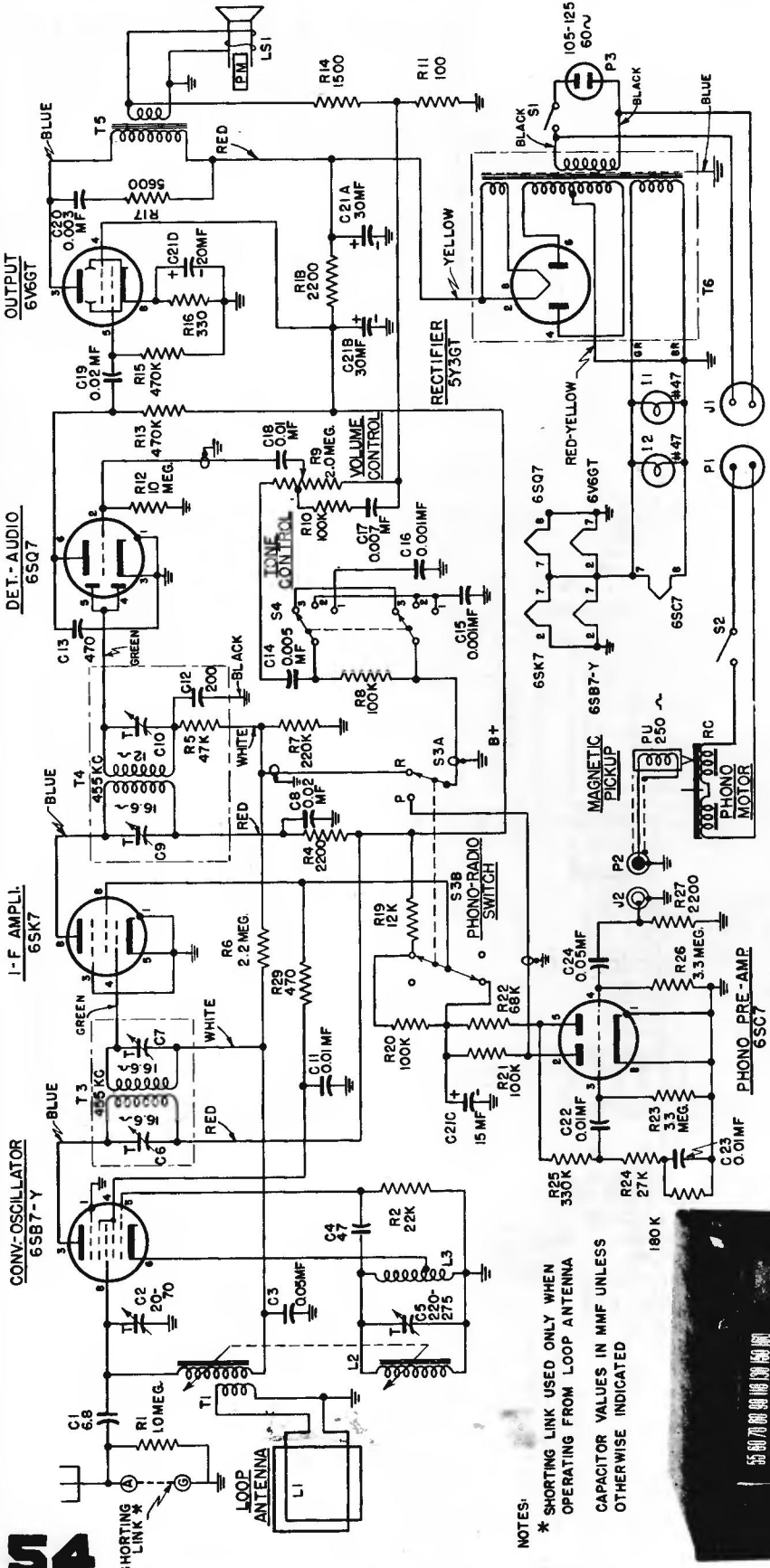

54

NOTES:
 * SHORTING LINK USED ONLY WHEN OPERATING FROM LOOP ANTENNA
 CAPACITOR VALUES IN MMF UNLESS OTHERWISE INDICATED



GENERAL ELECTRIC
RADIO
SERVICE DATA
FOR
MODEL 303

VALUES OBTAINED WITH 20 000 OHMS PER VOLT METER
 READINGS ARE BETWEEN PIN AND CHASSIS WITH A LINE VOLTAGE OF 117 VOLTS
 * VALUES OBTAINED WITH RADIO-PHONO SWITCH IN PHONO POSITION
 ALL READINGS TAKEN WITH RADIO-PHONO SWITCH IN RADIO POSITION UNLESS OTHERWISE INDICATED

MANUAL OF 1947 MOST-OFTEN-NEEDED RADIO DIAGRAMS

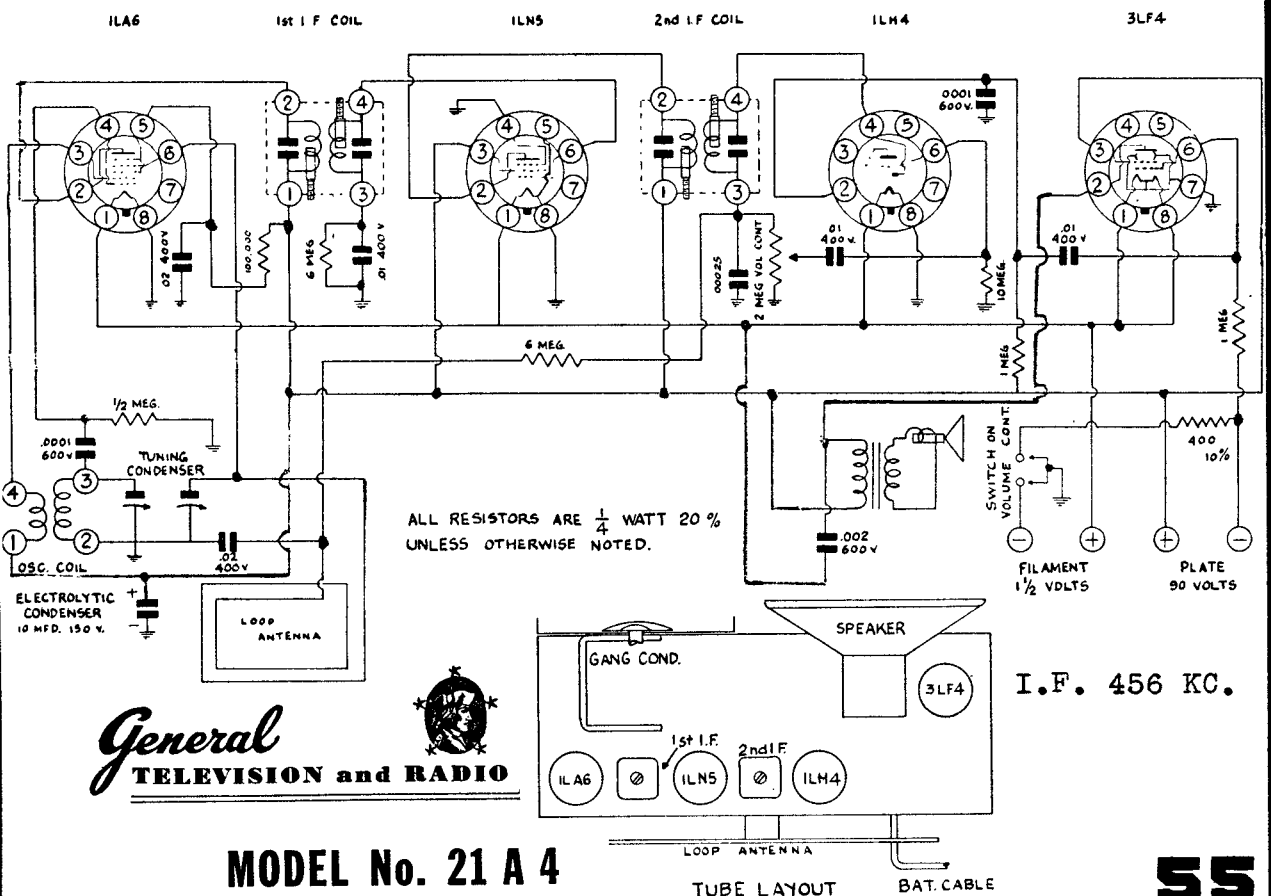
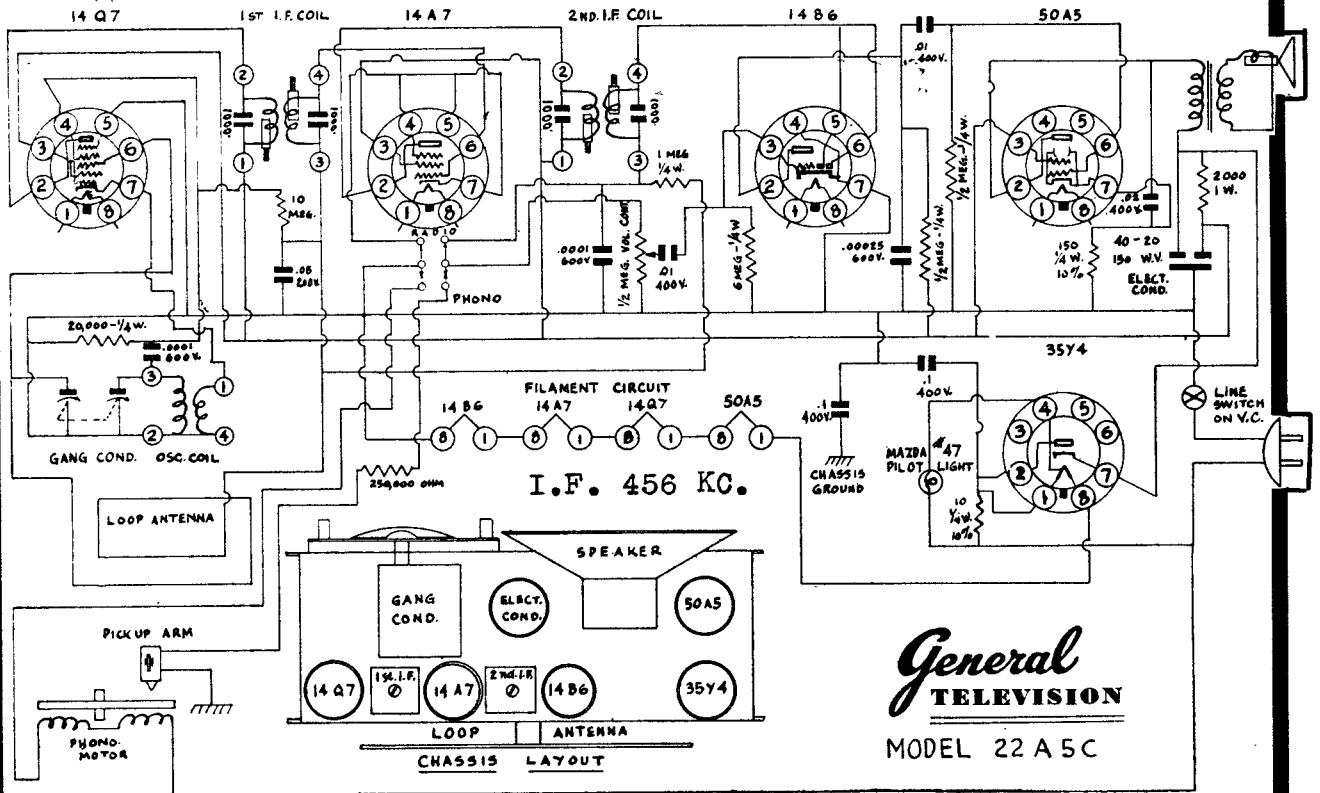

MANUAL OF 1947 MOST-OFTEN-NEEDED RADIO DIAGRAMS

W. T. GRANT COMPANY

Models 500 and 501—Series A

SIGNAL GENERATOR				TUNER SETTING	ADJUST TRIMMERS MAXIMUM OUTPUT (in order shown)
Frequency	Dummy Antenna	Connection to Radio	Ground Connection		
455 kc	.1 mf	Metal antenna plate	12SQ7 Pin 3	Iron cores all the way out	Trimmers on output and input I.F. cans
1720 kc	.1 mf	Metal antenna plate	12SQ7 Pin 3	Iron cores all the way out	Oscillator trimmer C6
1720 kc	200 mmf	External antenna clip	12SQ7 Pin 3	Iron cores all the way out	Antenna trimmer C2
1400 kc	200 mmf	External antenna clip	12SQ7 Pin 3	Turn dial to 1400 kc	Adjust position of ant. coil (see coil assembly view)
1720 kc	200 mmf	External antenna clip	12SQ7 Pin 3	Turn dial to 1720 kc	Antenna trimmer C2

VOLTAGES MEASURED WITH 1000 OHM PER VOLT VOLTMETER BETWEEN SOCKET TERMINALS & B—

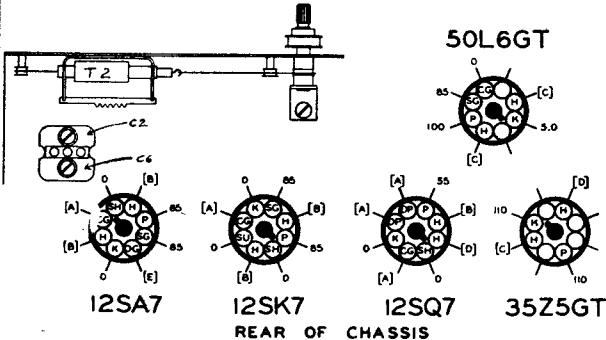

- [A] - CANNOT BE READ WITH VOLTMETER.
 - [B] - 12V A.C. BETWEEN PINS H&M.
 - [C] - 32V A.C. BETWEEN PINS H&H.
 - [D] - 07 V.A.C. BETWEEN PINS D & D.
 - [E] - 9 VOLTS OSCILLATOR GRID VOLTAGE SHOULD BE MEASURED WITH AN RF CHOKER PLACED IN SERIES WITH THE VOLTMETER LEAD DIRECTLY AT PIN OG.
- A.C. LINE VOLTAGE 117 VOLTS POWER CONSUMPTION 30 WATTS.

After the antenna coil has been tracked at 1400 Kc. it is necessary to check the antenna trimmer (C2) adjustment again at 1720 Kc. If no appreciable change in trimmer adjustment is made the coil is in track, if the trimmer requires considerable change it will be necessary to again adjust the position of the antenna coil at 1400 Kc. These two adjustments should be tried several times until no change of trimmer adjustment is required at 1720 Kc.

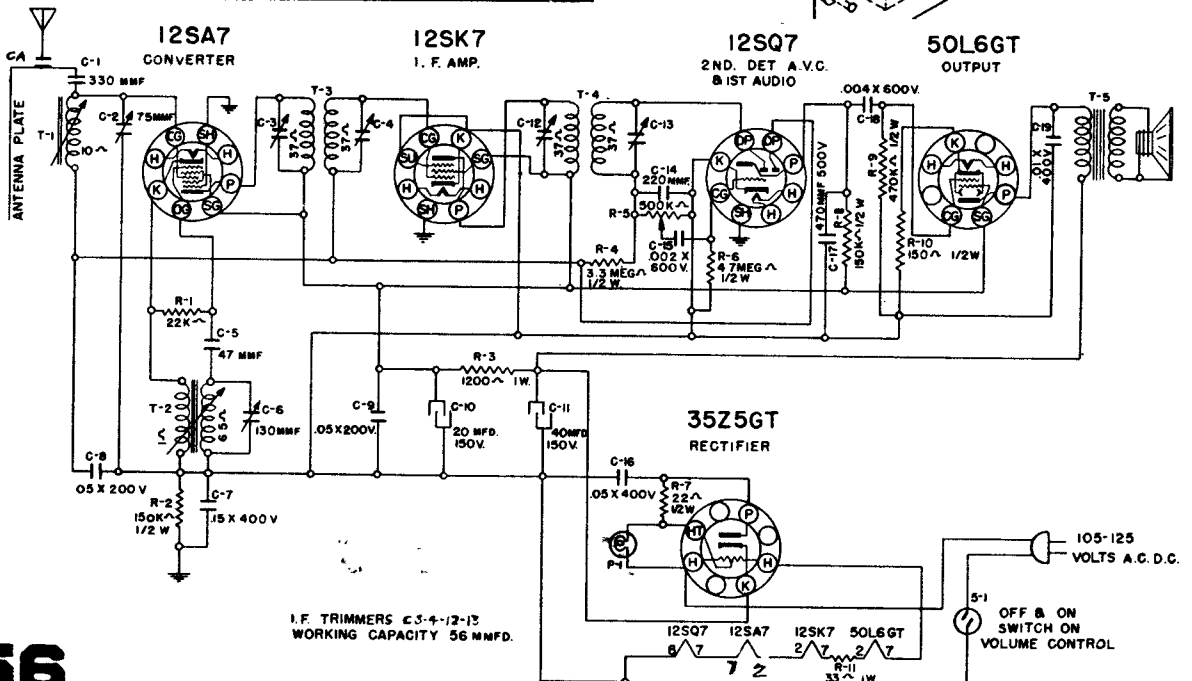
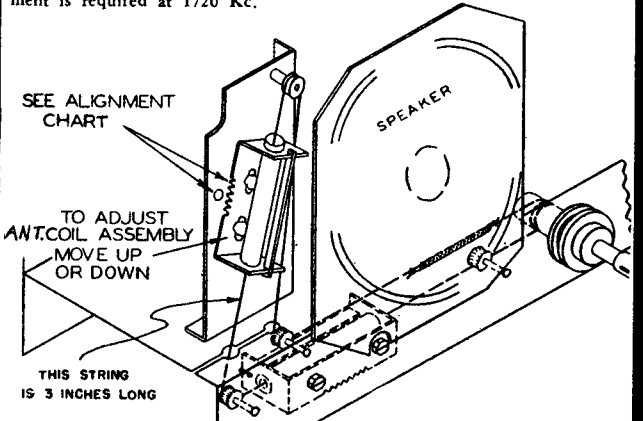

OLYMPIC TRU-BASE RADIO

Models 6-601 W (Walnut) 6-601 V (Ivory) & 6-602 Wood

1947 MOST-OFTEN-NEEDED RADIO DIAGRAMS

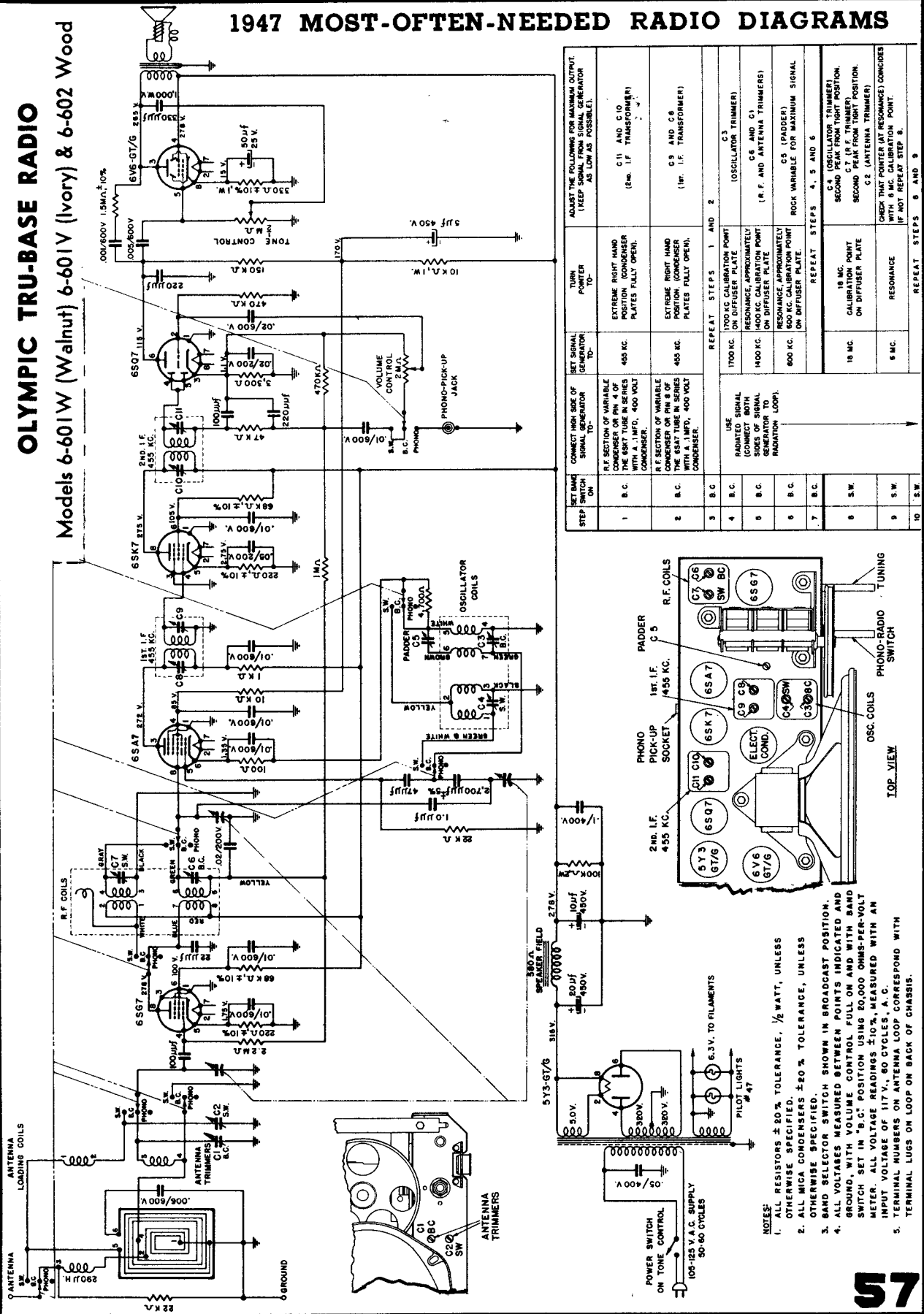

SET DIAGNOSTIC STEP FOLLOW UP ON	CONNECT HIGH SIDE OF SIGNAL GENERATOR TO:	SET SIGNAL GENERATOR TO:	TUNE PIONEER TO:	ADJUST THE FOLLOWING FOR MAXIMUM OUTPUT (KEEP SIGNAL FROM SIGNAL GENERATOR AS LOW AS POSSIBLE).
1 B.C.	R.F. SECTION OF VARIABLE CONDENSER ON PIN 4 OF THE 6SK7 TUBE IN SERIES WITH A .1 MFD. 400 VOLT CONDENSER.	455 KC.	EXTREME RIGHT HAND POSITION CONDENSER PLATES FULLY OPEN.	C11 AUS. C10 (8M. I.F. TRANSFORMER)
2 B.C.	R.F. SECTION OF VARIABLE CONDENSER ON PIN 2 OF THE 6SA7 TUBE IN SERIES WITH A .1 MFD. 400 VOLT CONDENSER.	455 KC.	EXTREME RIGHT HAND POSITION CONDENSER PLATES FULLY OPEN.	C9 AND C8 (1M. I.F. TRANSFORMER)
3 B.C.	USE RADIATED SIGNAL (CONNECT BOTH SIGNAL GENERATOR TO RADIATION LOOP).	REPEAT STEPS 1 AND 2	1700 KC. CALIBRATION POINT ON DIFFUSER PLATE	
4 B.C.		1700 KC.	RESONANCE, APPROXIMATELY	C3 (OSCILLATOR TRIMMER)
5 B.C.		1400 KC.	LOW DIFFUSER PLATE	C6 AND C1 (R.F. AND ANTENNA TRIMMERS)
6 B.C.		600 KC.	RESONANCE, APPROXIMATELY	C5 (PADDER)
7 B.C.		REPEAT STEPS 4, 5 AND 6	800 KC. CALIBRATION POINT ON DIFFUSER PLATE.	ROCK VARIABLE FOR MAXIMUM SIGNAL
8 S.W.		18 MC.	CALIBRATION POINT ON DIFFUSER PLATE	C4 (OSCILLATOR TRIMMER) POSITION SECOND C3 (R.F. TRIMMER)
9 S.W.		6 MC.	RESONANCE	C2 (ANTENNA TRIMMER) CHECK THAT POINTER (AT RESONANCE) COINCIDES WITH 8 MC. CALIBRATION POINT. IF NOT REPEAT STEP 8.
10 S.W.			REPEAT STEPS 6 AND 9	

- NOTES:
- ALL RESISTORS $\pm 20\%$ TOLERANCE, $\frac{1}{2}$ WATT, UNLESS OTHERWISE SPECIFIED.
 - ALL MICA CONDENSERS $\pm 20\%$ TOLERANCE, UNLESS OTHERWISE SPECIFIED.
 - BAND SELECTOR SWITCH SHOWN IN BROADCAST POSITION.
 - ALL VOLTAGES MEASURED BETWEEN POINTS INDICATED AND GROUND WITH VOLUME CONTROL FULL ON AND WITH RADIO SWITCH SET IN "S.C." POSITION USING 20,000 OHMS-PER-VOLT METER. ALL VOLTAGE READINGS $\pm 10\%$, MEASURED WITH AN INPUT VOLTAGE OF 117 V., 60 CYCLES, A.C.
 - TERMINAL NUMBERS ON ANTENNA LOOP CORRESPOND WITH TERMINAL LUGS ON LOOP ON BACK OF CHASSIS.

MANUAL OF 1947 MOST-OFTEN-NEEDED RADIO DIAGRAMS

OLYMPIC RADIO

Model 6-606

HAMILTON RADIO

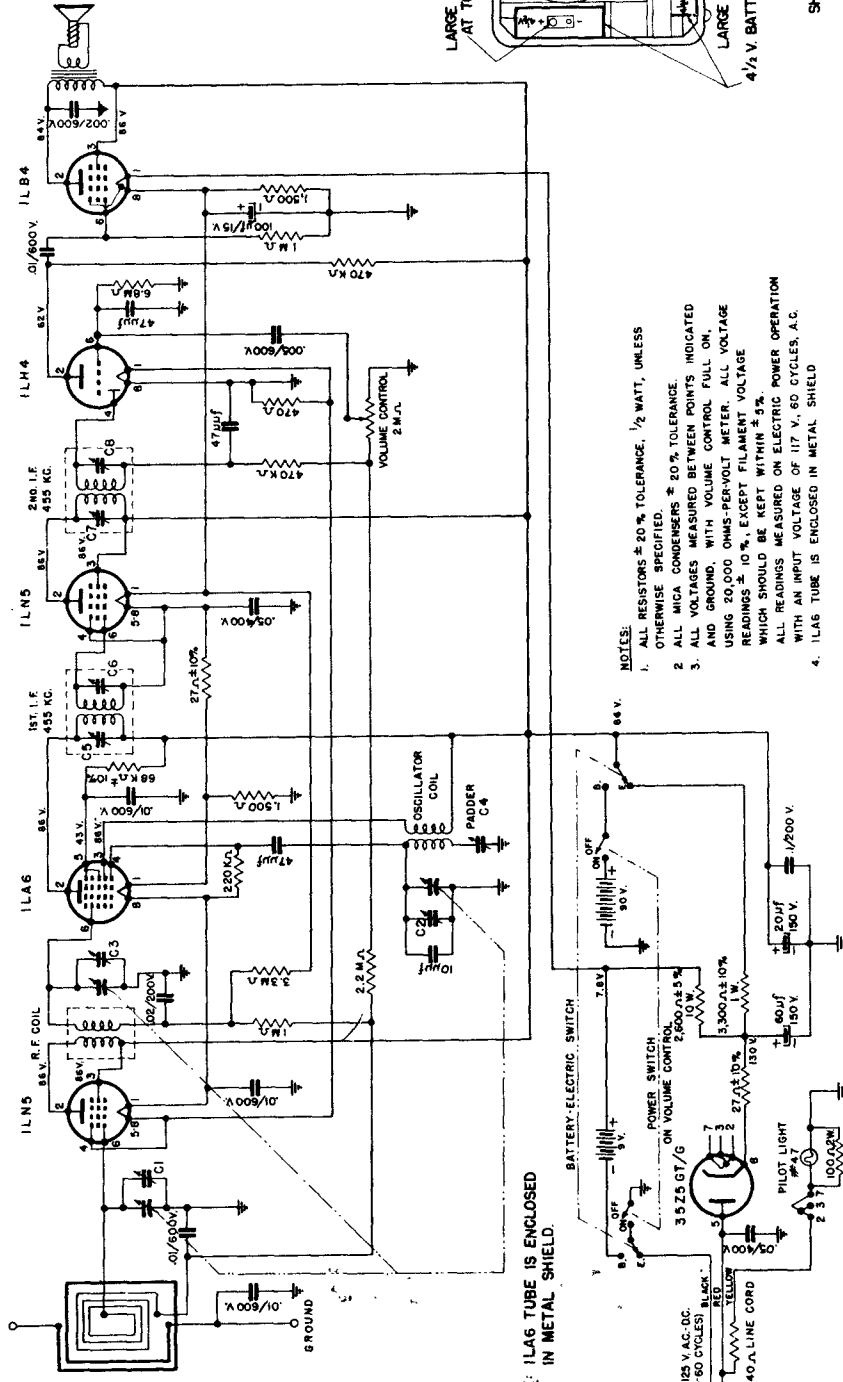

NOTE: 1LA6 TUBE IS ENCLOSED IN METAL SHIELD.

- NOTES:
1. ALL RESISTORS ± 20% TOLERANCE, 1/2 WATT, UNLESS OTHERWISE SPECIFIED.
 2. ALL MICA CONDENSERS ± 20% TOLERANCE.
 3. ALL VOLTAGES MEASURED BETWEEN POINTS INDICATED AND GROUND, WITH VOLUME CONTROL FULL ON, USING 20,000 OHMS-PER-VOLT METER. ALL VOLTAGE READINGS ± 10%, EXCEPT FILAMENT VOLTAGE WHICH SHOULD BE KEPT WITHIN ± 5%.
 4. ALL READINGS MEASURED ON ELECTRIC POWER OPERATION WITH AN INPUT VOLTAGE OF 117 V. 60 CYCLES, A.C.

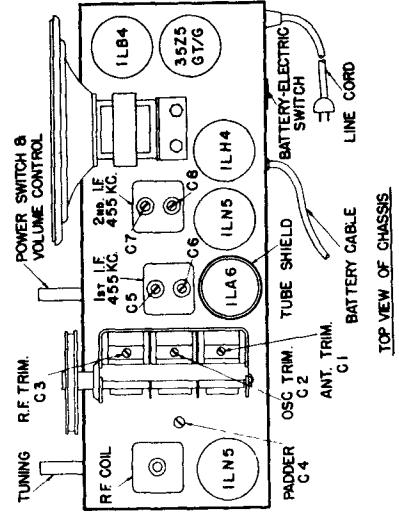
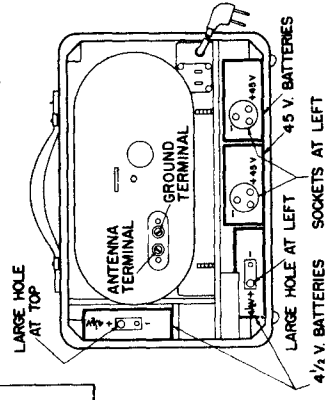

TOP VIEW OF CHASSIS

ALIGNMENT PROCEDURE CHART

STEP	CONNECT HIGH SIDE OF SIGNAL GENERATOR TO -	SET POINTER TO -	ADJUST THE FOLLOWING FOR MAXIMUM OUTPUT. (KEEP SIGNAL FROM SIGNAL GENERATOR AS LOW AS POSSIBLE)
1	R.F. SECTION OF VARIABLE CONDENSER IN SERIES WITH 1MFD. COND.	455 KC.	C8, C7, C6, C5 AND REPEAT IN SAME ORDER (1ST AND 2ND I.F. TRANSFORMERS)
2	ANTENNA TERMINAL OF ANTENNA LOOP IN SERIES WITH 50 MMFD. COND.	1500 KC. (150 ON DIAL)	OSCILLATOR, R.F. AND ANTENNA TRIMMERS C2, C3, C1
3		600 KC. (APPROX. 6D ON DIAL)	C4 PADDER
4			ROCK DIAL FOR MAXIMUM SIGNAL
			REPEAT STEPS 2 AND 3

1947 MOST-OFTEN-NEEDED RADIO DIAGRAMS

OLYMPIC TRU-BASE RADIO

Model 6-604W (Walnut) and 6-604V (Ivory)

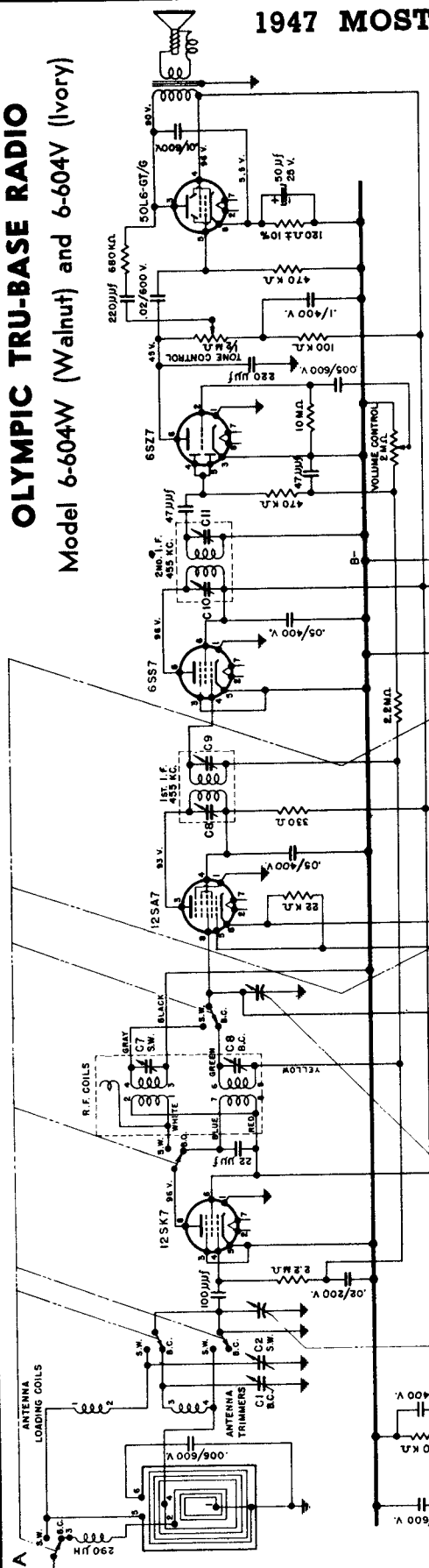

ALIGNMENT PROCEDURE CHART						
STEP	SET BAND SWITCH ON	CONNECT HIGH SIDE OF SIGNAL GENERATOR TO-	SET SIGNAL GENERATOR TO-	TURN POINTER TO-	ADJUST THE FOLLOWING FOR MAXIMUM OUTPUT (KEEP SIGNAL FROM SIGNAL GENERATOR AS LOW AS POSSIBLE).	
1	B.C.	R.F. SECTION OF VARIABLE CONDENSER OR PIN 4 OF THE 6S57 TUBE IN SERIES WITH A .1 MFD., 400 VOLT CONDENSER.	455 KC	EXTREME RIGHT HAND POSITION (CONDENSER PLATES FULLY OPEN).	C11 AND C10 (2nd I.F. TRANSFORMER)	
2	B.C.	R.F. SECTION OF VARIABLE CONDENSER OR PIN 8 OF THE 12SA7 TUBE IN SERIES WITH A .1 MFD., 400 VOLT CONDENSER.	455 KC	EXTREME RIGHT HAND POSITION (CONDENSER PLATES FULLY OPEN).	C9 AND C8 (1st I.F. TRANSFORMER)	
3	B.C.	REPEAT STEPS 1 AND 2				
4	B.C.	USE RADIATED SIGNAL (CONNECT BOTH SIDES OF SIGNAL GENERATOR TO RADATION LOOP).	1700 KC	1700 KC. CALIBRATION POINT ON DIFFUSER PLATE	C3 (OSCILLATOR TRIMMER)	
5	B.C.		1400 KC	1400 KC. CALIBRATION POINT ON DIFFUSER PLATE	C6 AND C1 (R.F. AND ANTENNA TRIMMERS)	
6	B.C.		600 KC.	600 KC. CALIBRATION POINT ON DIFFUSER PLATE.	C5 (PADDER) ROCK VARIABLE FOR MAXIMUM SIGNAL	
7	B.C.		REPEAT STEPS 4, 5 AND 6			
8	S.W.		18 MC.	18 MC. CALIBRATION POINT ON DIFFUSER PLATE	C4 (OSCILLATOR TRIMMER) SECOND PEAK FROM TIGHT POSITION. C7 (R.F. TRIMMER) SECOND PEAK FROM TIGHT POSITION C2 (ANTENNA TRIMMER)	
9	S.W.		6 MC.	RESONANCE	CHECK THAT POINTER (AT RESONANCE) COINCIDES WITH 6 MC. CALIBRATION POINT IF NOT REPEAT STEP 6	
10	S.W.	REPEAT STEPS 8 AND 9				

NOTE: In order to adjust the short wave oscillator trimmer and the short wave r-f trimmer accurately to the fundamental frequency and not to the image signal, turn the trimmers first to the maximum capacity position (fully tight). From this position loosen the trimmer through one peak indication on the outpumper until a second peak is obtained. Adjust for maximum output on this second peak.

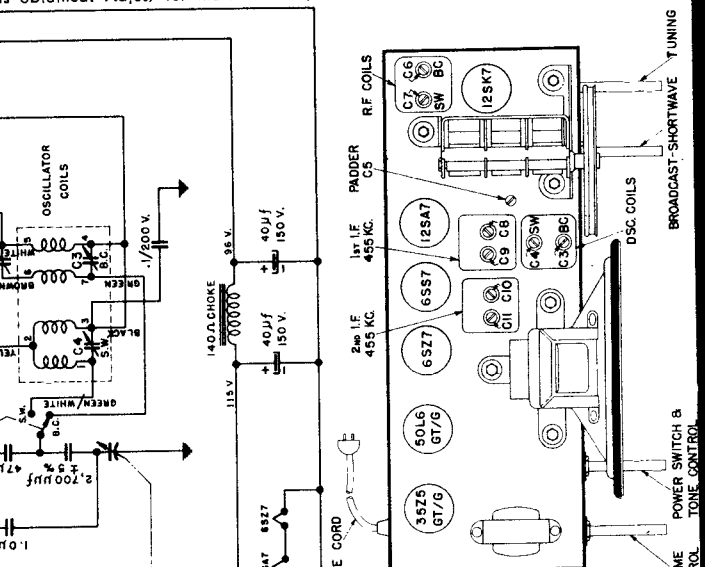

- NOTES:
- ALL RESISTORS ±20% TOLERANCE, 1/2 WATT, UNLESS OTHERWISE SPECIFIED.
 - ALL MICA CONDENSERS ±10% TOLERANCE, UNLESS OTHERWISE SPECIFIED.
 - BAND SELECTOR SWITCH SHOWN IN BROADCAST POSITION. ALL VOLTAGES MEASURED BETWEEN POINTS INDICATED AND B+ WITH VOLUME CONTROL FULL ON AND WITH BAND SWITCH SET IN "B.C." POSITION. USING 20,000 OHMS-PER-VOLT METER. ALL VOLTAGE READINGS ±10%, MEASURED WITH AN INPUT VOLTAGE OF 117 V., 60 CYCLES A.C.
 - TERMINAL NUMBERS ON ANTENNA LOOP CORRESPOND WITH TERMINAL LUGS ON LOOP ON BACK OF CHASSIS.

LEGEND:
 CHASSIS GROUND
 VOLUME CONTROL
 POWER SWITCH & TONE CONTROL
 BROADCAST-SHORTWAVE TUNING

MANUAL OF 1947 MOST-OFTEN-NEEDED RADIO DIAGRAMS

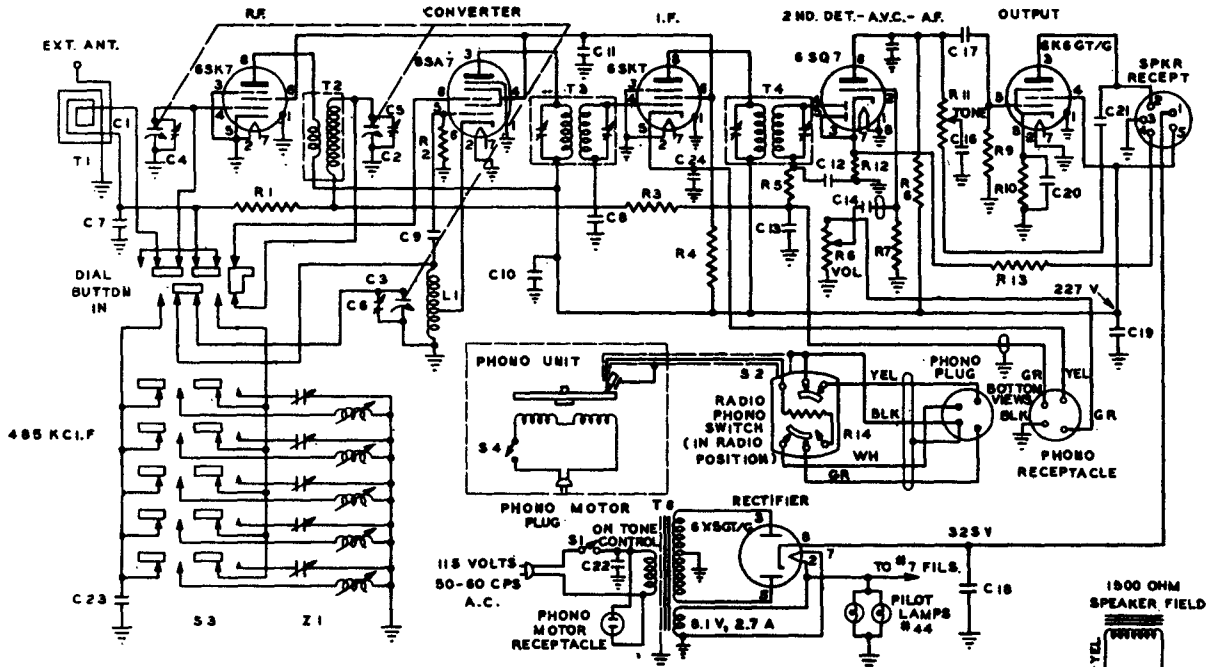

SYMBOL	DESCRIPTION
C1-C3-C8	Three-Section Variable (888-388-180 Mmf.)
C4, C5, C6	Trimmers; Part of Variable Condenser
C7, C8	.05 Mfd, 200 Volt, Tubular Paper
C9, C12	100 Mmf ± 20%, Mica
C13, C15	.05 Mfd, 400 Volt, Tubular Paper
C10, C11, C24	.05 Mfd, 400 Volt, Tubular Paper
C14, C16	.005 Mfd, 600 Volt, Tubular Paper
C17	.01 Mfd, 600 Volt, Tubular Paper
C18-C19-C20	Dry Electrolytic Condenser (20-20-20 Mfd/450-450-25 Volt)
C21	.001 Mfd, 600 Volt, Tubular Paper
C22	.01 Mfd, 600 Volt, Tubular Paper (Metal Can)

C23	500 Mmf ± 5%, Silver Mica
L1	Oscillator Coil
LS	10" Electrodynamic Speaker (with Transformer)
R1, R2, R14	.22 Megohm ± 20%, ½ Watt
R2	22,000 Ohm ± 20%, ½ Watt
R3	2.2 Megohm ± 20%, ½ Watt
R4	10,000 Ohm ± 10%, 2 Watt
R5	47,000 Ohm ± 20%, ½ Watt
R6	.5 Megohm Potentiometer (Volume)
R7	10 Megohm ± 20%, ½ Watt
R9	.47 Megohm ± 20%, ½ Watt
R10	560 Ohm ± 10%, ½ Watt
R11	.25 Megohm Potentiometer With Switch (Tone)
R12	47 Ohm ± 20%, ½ Watt
R13	330 Ohm ± 20%, ½ Watt

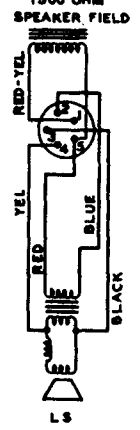

PIN NO.	1	2	3	4	5	6	7	8
6SK7 (R.F.)	0	0	0	-.5	0	+85	6.1A.C.	+227
6SA7	0	0	+227	+85	-7	0	6.1A.C.	-7
6SK7 (I.F.)	0	0	0	-.7	0	+85	6.1A.C.	+227
6SQ7	0	-.5	0	-.25	0	+95	6.1A.C.	0
6K6GT/G	0	0	+217	+227	0	+325 *	6.1A.C.	+15
6X5GT/G	0	6.1A.C.	290A.C.	-	290A.C.	-	0	+325

D.C. voltages measured with 20,000 ohm/volt meter.
 A.C. voltages measured with 1,000 ohm/volt meter.
 All voltages measured with reference to chassis.
 Line voltage 117.5.

* Means tie point.
 NOTE: The above readings are obtained with no signal input to the receiver and the radio-phono switch in the RADIO position.

Hoffman Model A500 with Chassis 107S is electrically identical with Chassis 107 except for the following:

1. Ten-inch P.M. speaker, part number 9010, has been substituted for ten-inch electrodynamic speaker, part number 9012.
2. A 1500-ohm resistor, part number 4701, has been connected in the filter circuit in place of the 1500-ohm speaker field.

Hoffman Radio Corp.
 Model A500, Chassis 107

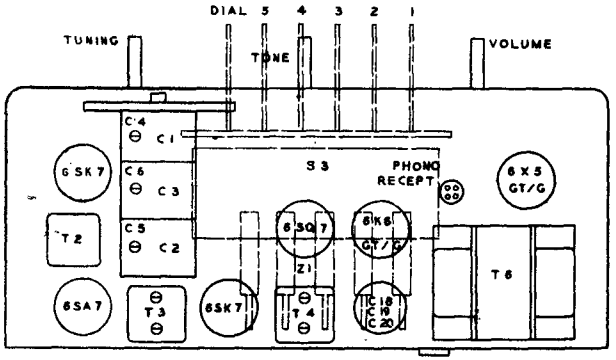

MANUAL OF 1947 MOST-OFTEN-NEEDED RADIO DIAGRAMS

SYMBOL	DESCRIPTION
C1-C2, C3-C4, C5-C6	Three-Section Variable with Split Stator, (160-260, 160-260, 160-260 Mmf.)
C7, C8, C9	Three-Section Trimmer Assembly
C10, C11, C12	Three-Section Trimmer Assembly
C13, C14, C15	Three-Section Trimmer Assembly
C16	110-560 Mmf. Padder, Band "A"
C17, C18	.05 Mfd., 200 Volt, Tubular Paper
C19	500 Mmf. \pm 5%, Silver Mica
C20	47 Mmf. \pm 10%, Mica
C21, C22	.05 Mfd., 400 Volt, Tubular Paper
C23, C24, C25	100 Mmf. \pm 20%, Mica
C26	1050 Mmf. \pm 5%, Mica
C27	2300 Mmf. \pm 5%, Mica
C28	.005 Mfd., 600 Volt, Tubular Paper
C29	10 Mfd., 450 Volt, Tubular Electrolytic
C30	.01 Mfd., 400 Volt, Tubular Paper
C31, C32, C33	
C34	.5 Mfd., 200 Volt, Tubular Paper
C35	.02 Mfd., 400 Volt, Tubular Paper
C36, C37	20-20 Mfd./450-450-25 V. Electrolytic
C38-C39-C40	
C41, C42	.01 Mfd., 600 Volt, Tubular Paper
C43	.01 Mfd., 600 Volt, Tubular Paper (Metal Can)
C44	330 Mmf. \pm 5%, Mica
C45	650 Mmf. \pm 5%, Mica
L1	Loop Antenna
L2-L4	Oscillator Coil (Band "A")
L5	Oscillator Coil (Bands "B" and "C")
L6	5 HY Choke (Base Board)
L7	12-inch Loudspeaker, Permanent Magnet
R1	.1 Megohm \pm 20%, $\frac{1}{2}$ Watt
R2	22,000 Ohm \pm 20%, $\frac{1}{2}$ Watt
R3	2.2 Megohm \pm 20%, $\frac{1}{2}$ Watt
R4	10,000 Ohm \pm 20%, $\frac{1}{2}$ Watt
R5	10 Megohm \pm 20%, $\frac{1}{2}$ Watt
R6	5 Megohm Potentiometer (Volume Control)
R7	.22 Megohm \pm 20%, $\frac{1}{2}$ Watt
R8, R9, R10	1 Megohm \pm 20%, $\frac{1}{2}$ Watt
R11	47,000 Ohm \pm 20%, 1 Watt
R12	47,000 Ohm \pm 20%, $\frac{1}{2}$ Watt
R15, R16	200 Ohm \pm 20%, $\frac{1}{2}$ Watt
R17, R18	10,000 Ohm \pm 20%, $\frac{1}{2}$ Watt
R19	.25 Meg. Pot. with Switch (Treble Control)
R20	50,000 Ohm Potentiometer (Bass Control)
R21, R22	.47 Megohm \pm 20%, $\frac{1}{2}$ Watt
R23	220 Ohm \pm 20%, 3 Watt
R24	500 Ohm \pm 10%, 20 Watt
R25	47,000 Ohm \pm 5%, $\frac{1}{2}$ Watt
R26	22,000 Ohm \pm 5%, $\frac{1}{2}$ Watt
S1	Band Change Switch
S2	Pushbutton Switch Assembly
S3	On-Off Switch (on Trouble Control)
T1	Antenna Coil (Band "A")
T2-T3	Antenna Coil (Bands "B" and "C")
T4	R.F. Coil, Shielded (Band "A")
T5-T6	R.F. Coil (Bands "B" and "C")
T7	Input I.F. Transformer
T8	Output I.F. Transformer
T9	Power Transformer

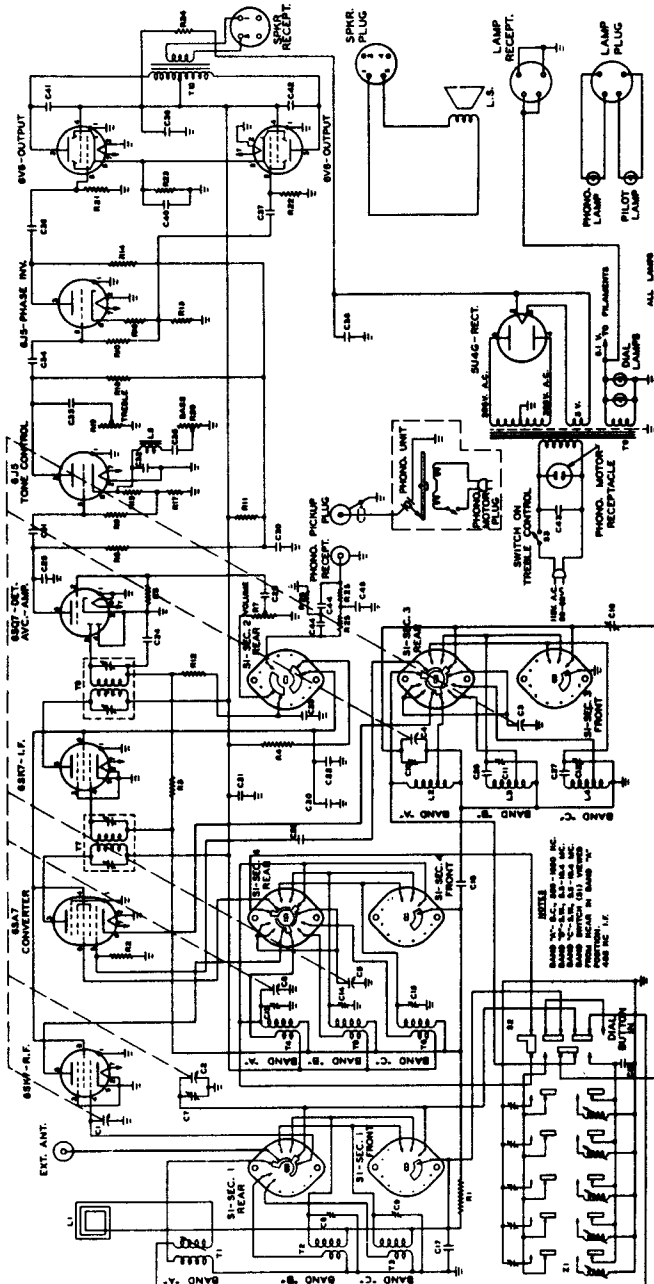

MODEL A 501 CHASSIS No. 1085

Hoffman
RADIO CORP.

LOS ANGELES, CALIFORNIA

TUNING RANGES:	
Band "A"	540 Kc to 1600 Kc.
Band "B"	5.6 Mc to 10.4 Mc
Band "C"	9.4 Mc to 19.4 Mc
Intermediate Frequency	455 Kc

HOWARD RADIO COMPANY

Model 901-AP

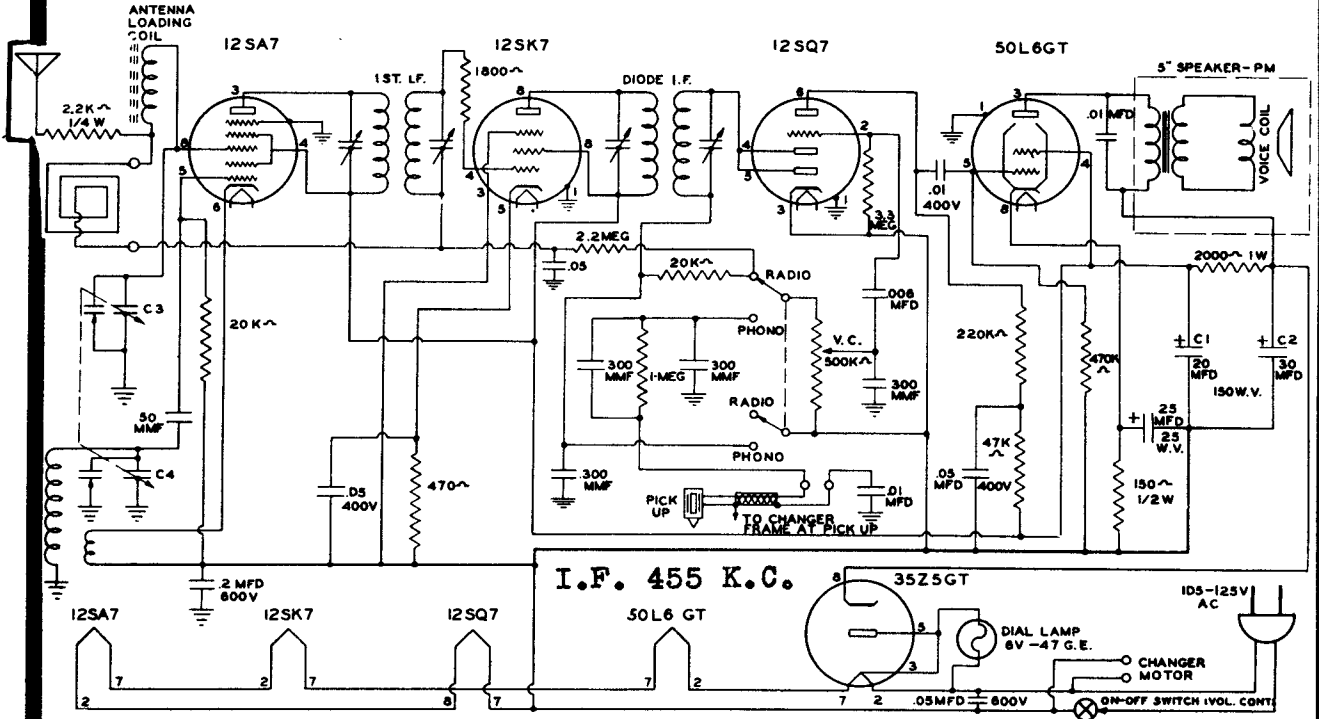

I.F. 455 K.C.

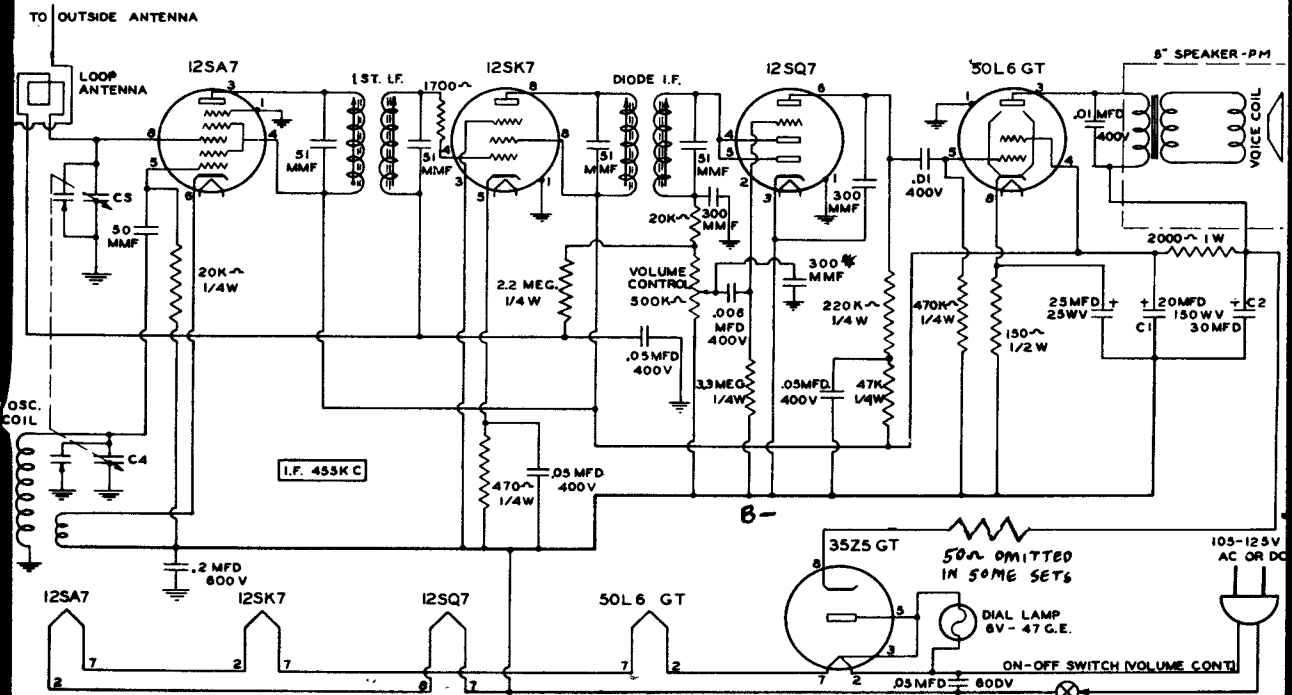

* IN SOME SETS THIS CONDENSER GOES TO B- INSTEAD OF GRN.

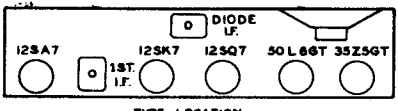

HOWARD RADIO CO.
MODEL 901-A
SD-0001-D

1947 MOST-OFTEN-NEEDED RADIO DIAGRAMS

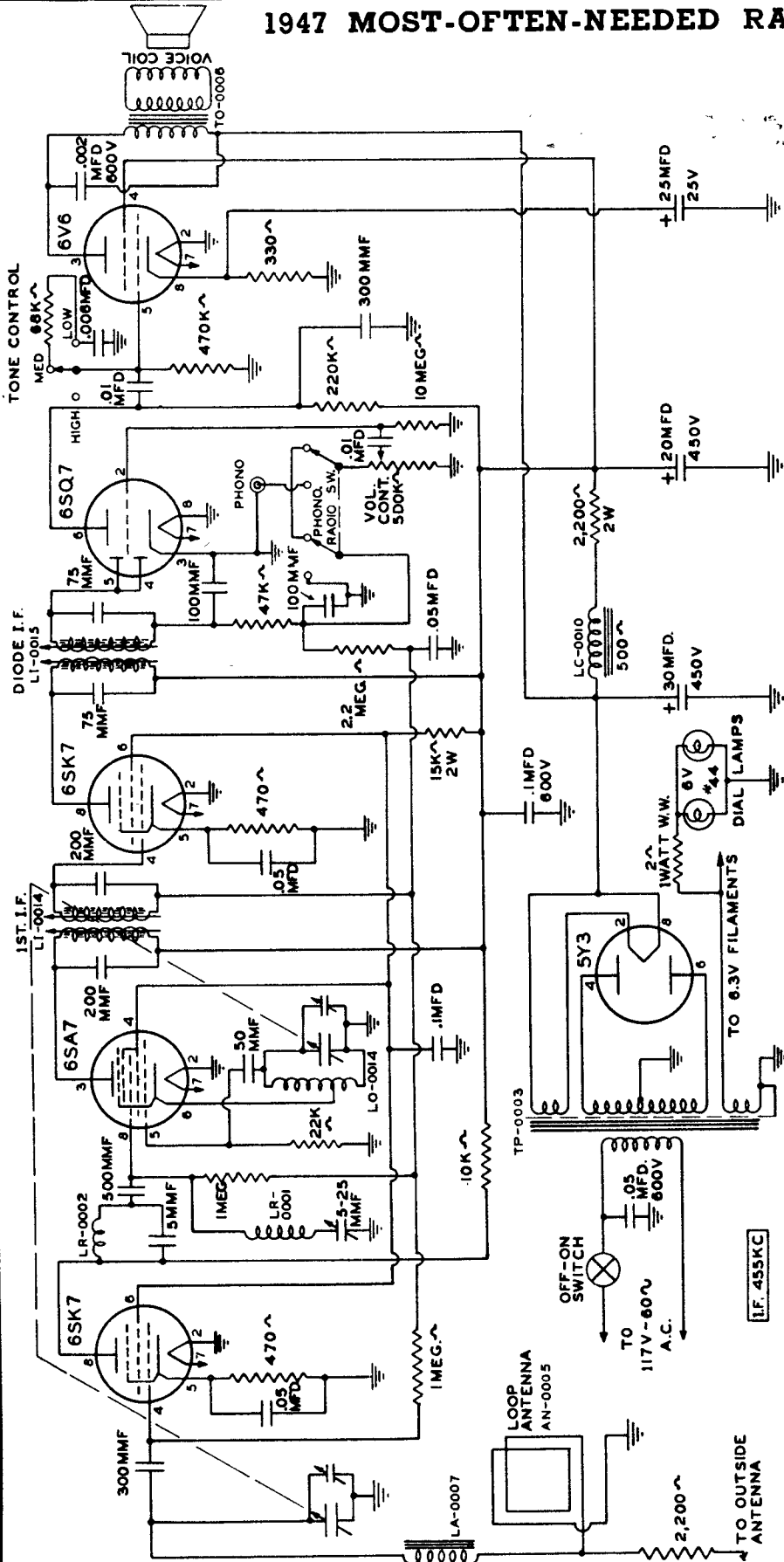

PHONO-RADIO SWITCH SHOWN IN RADIO POSITION.

Voltage measurements from ground using vacuum tube voltmeter.

Tube	Use	Cath.	S.G.	Plate	B+
6SK7	R.F.	1.8	79	210	
6SA7	Converter	79	79	230	
6SK7	I.F.	2.3	79	240	
6SQ7	Det.	11	235	115	
6V6	Out.			225	
5Y3				AC	285

HOWARD RADIO COMPANY

MODEL No. 906



HOWARD RADIO

MODEL 920 BATTERY SET

BATTERIES

1½ Volt "A" Battery
90 Volt "B" Battery
Follow connections
as shown on Battery
Label.

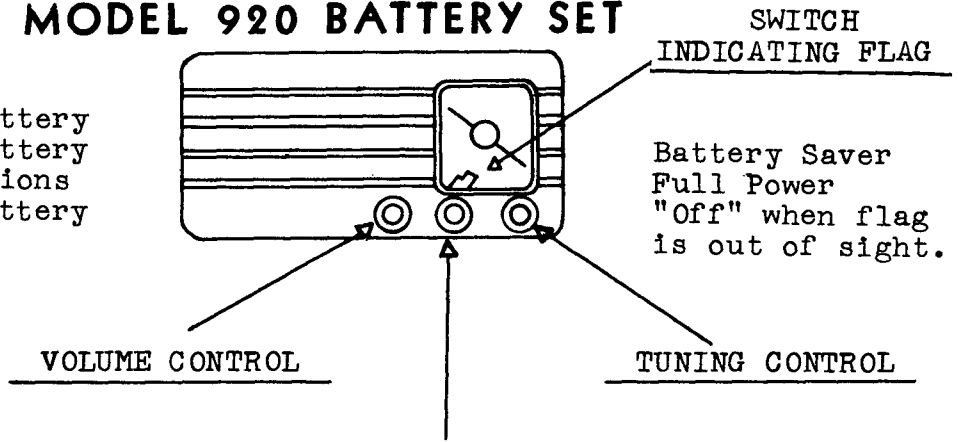

BATTERY CONSERVATION

1. Turn Battery Switch "Off" when set is not in use.
2. Use "Battery Saver" on all strong stations.
3. Use heavy duty pack or batteries.
4. The following batteries are some well known makes that can be used with this instrument;
Burgess No.17GD60
Eveready No.758

BATTERY SWITCH

"OFF POSITION": Switch turned counter-clockwise

"BATTERY SAVER": Switch turned clockwise - one step.

"FULL POWER": Switch turned clockwise - two steps. Flag will indicate "Full Power".

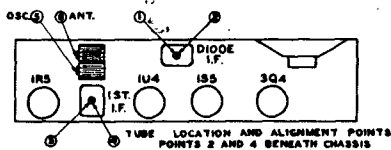
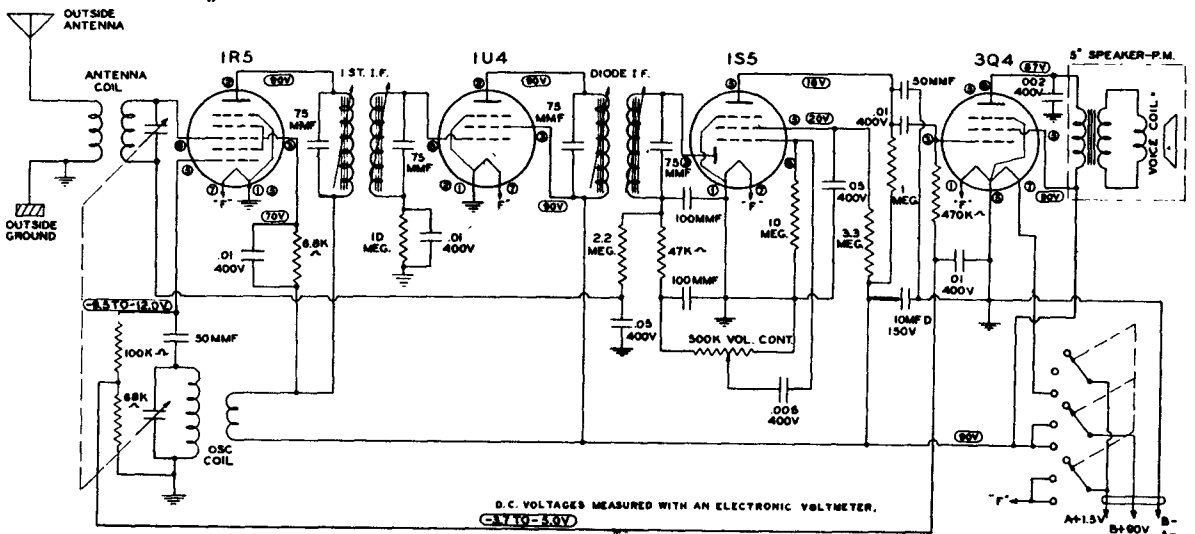

I.F. 455 KC

MANUAL OF 1947 MOST-OFTEN-NEEDED RADIO DIAGRAMS

International Detrola Corp.

FIVE-TUBE, BROADCAST BAND, AC

Radio Chassis Model 558

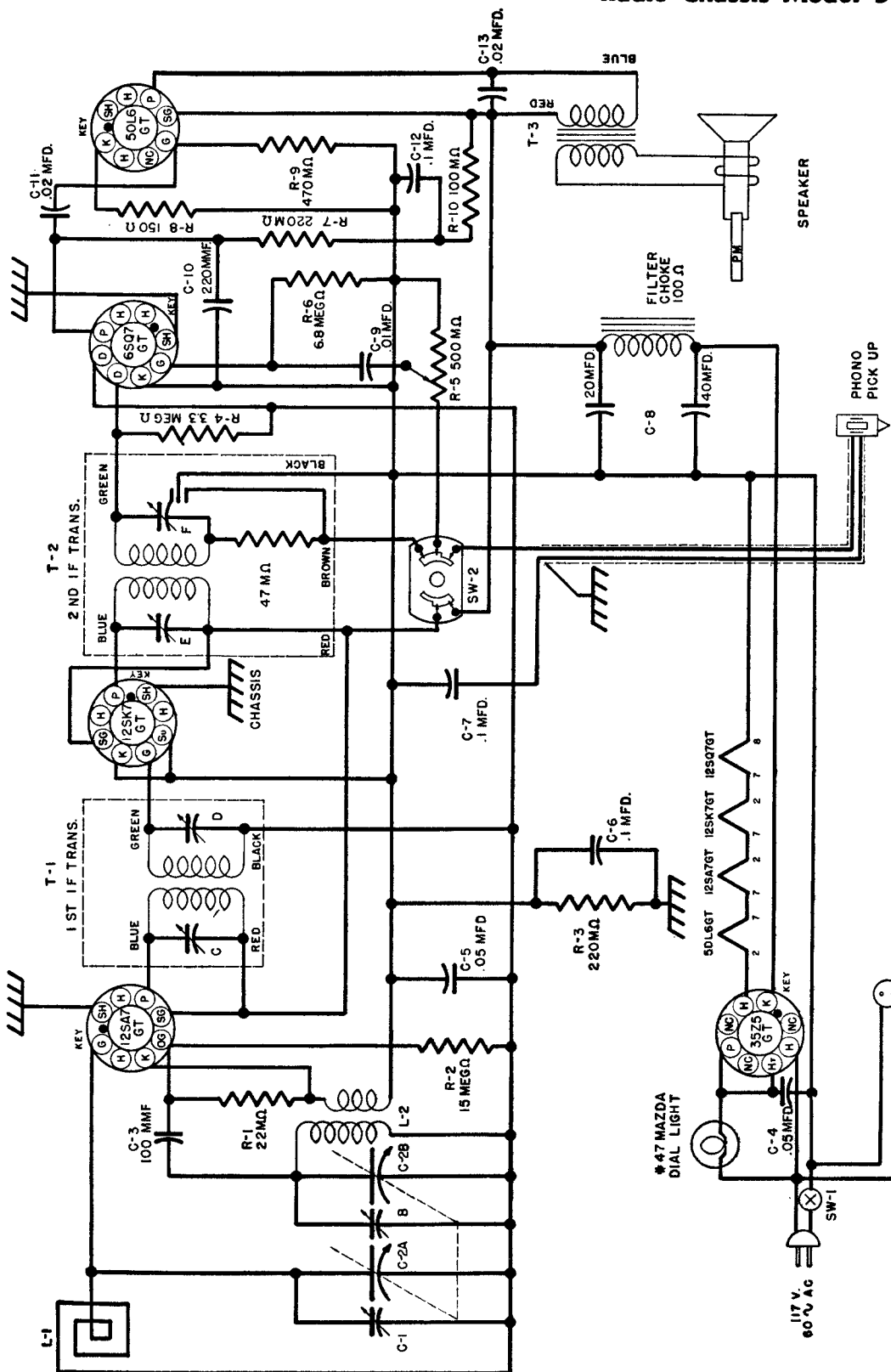

AC TO PHONO MOTOR

455 KC IF

ALL TUBE SOCKETS SHOWN FROM PIN END VIEW. ALL SWITCHES SHOWN IN COUNTERCLOCKWISE POSITION. SHAFT END VIEW

MANUAL OF 1947 MOST-OFTEN-NEEDED RADIO DIAGRAMS

International Detrola Corp.

Radio Chassis Model 558

All DC voltages measured with a 1000 ohm-per-volt meter from ON-OFF switch (—B) to socket contact indicated. All AC voltages are measured from ON-OFF switch (—B) to socket contact indicated.

TUBE	POSITION	1	2	3	4	5	6	7	8
12SA7GT	Converter	0	36.3 AC	108	108	-5.6	0	23.8 AC	0
12SK7GT	IF Amplifier	0	11.4 AC	0	0	0	108	23.8 AC	108
12SQ7GT	Detector—1st Audio	0	0	0	0	0	43	11.4 AC	0
50L6GT	Power Output	0	85 AC	100	108	0	0	36.3 AC	7.3
35Z5GT	Rectifier	0	117 AC	112 AC	0	112 AC	0	85 AC	117

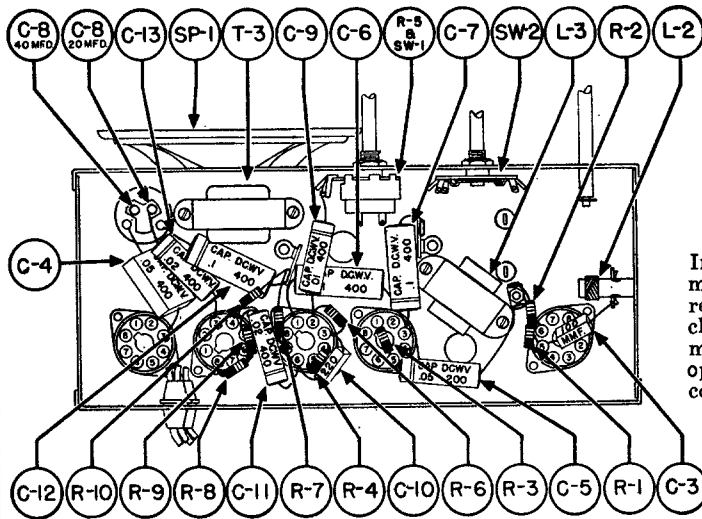

Volume Control full on. No signal.
Line voltage 117 volts AC.

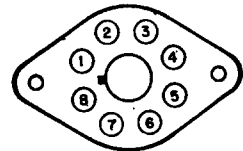

Intermediate Frequency and Oscillator adjustments may be made with the loop disconnected provided a resistor of 10,000 to 50,000 ohms is substituted to close the 12SA7GT grid circuit. The loop alignment must be done with the loop and chassis mounted in operating position in the cabinet. A single turn loosely coupled to loop may be substituted for RMA loop

ALIGNMENT PROCEDURE

GENERATOR	CONNECTION AT RADIO	DUMMY ANTENNA	DIAL	TO TUNE TRIMMERS	REMARKS
IF 455 kc.	12SA7GT grid	.1 mfd.	HF end	IF trimmers C D E F	Tune to max.
1620 kc.	12SA7GT grid	RMA loop	HF end	Osc. trimmer B	Set limit of band
1400 kc.	Through loop*	RMA loop	1400 kc.	Ant. trimmer A	Tune to max.

* Loop trimmer accessible through bottom of cabinet.

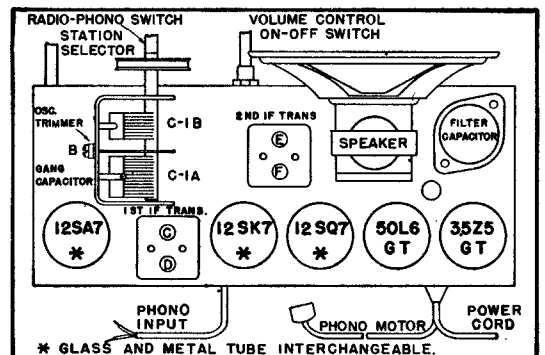
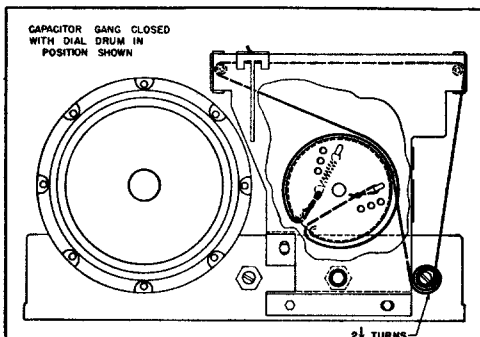

MANUAL OF 1947 MOST-OFTEN-NEEDED RADIO DIAGRAMS

LEAR

MODELS 565 565BL

566, 567, 568

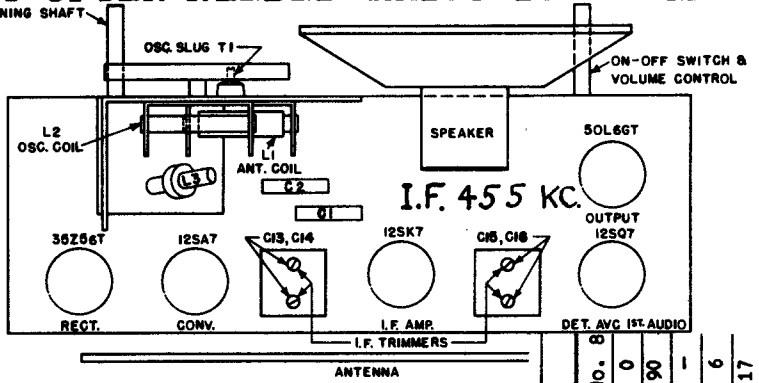
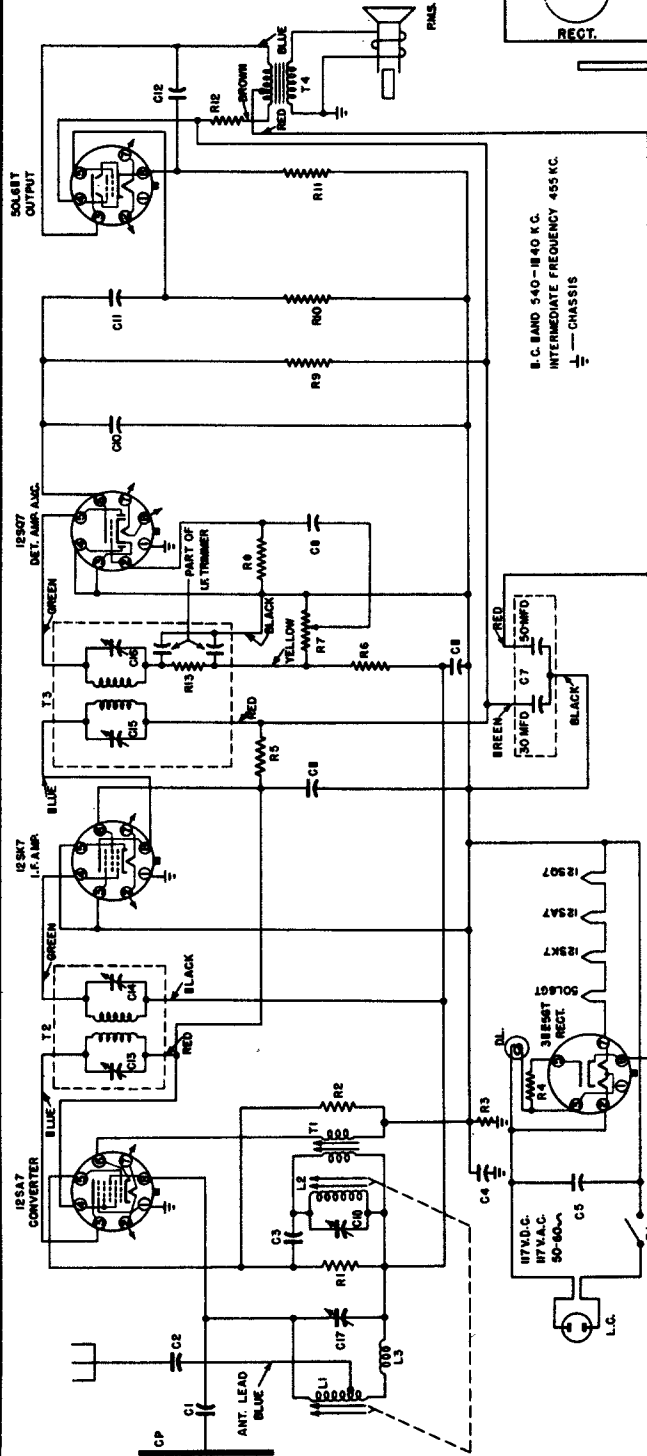

DWL. SYM.	PART NO.	DESCRIPTION	DWL. SYM.	PART NO.	DESCRIPTION
B1	55486	15 meg. 1/2 w. carbon resistor	CP	52378	Antenna Assy. Loop
B2	55479	22,000 ohm 1/2 w. carbon resistor	T1	54282	Oscillator Transformer Assy.
B3	55485	220,000 ohm 1/2 w. carbon resistor	T2	53358	#1 I.F. Transformer Assy.
B4	55460	15 ohm 1/2 w. carbon resistor	T3	53361	#2 I.F. Transformer Assy.
B5	55475	4,700 ohm 1/2 w. carbon resistor	T4	52531	Output Transformer Assy.
B6	55491	2.2 meg. 1/2 w. carbon resistor	C1	50553	22 mmfd. Mica Capacitor
B7, S1	56340	500,000 ohm vol. control & line sw.	C2	50553	47 mmfd. Mica Capacitor
B8	55491	2.2 meg. 1/2 w. carbon resistor	C3	50555	47 mmfd. 400 v. Paper Capacitor
B9	55487	470,000 ohm 1/2 w. carbon resistor	C4	56631	.05 mid. 400 v. Paper Capacitor
B10	55487	470,000 ohm 1/2 w. carbon resistor	C5	56656	.1 mid. 400 v. Paper Capacitor
B11	55466	150 ohm 1/2 w. carbon resistor	C6	56631	.1 mid. 400 v. Paper Capacitor
B12	55674	1,200 ohm 1/2 w. carbon resistor	C7	52326	50 - 30 mid. 150 v. Electrolytic
B13	55481	47,000 ohm 1/2 w. carbon resistor	C8	56600	.15 mid. 200 v. Paper Capacitor
L1, L2	54284	Slug tuner & puller Assy.	C9	56596	220 mmfd. Mica Capacitor
C17, C18	53395	Antenna loading coil	C10	50559	.504 mid. 200 v. Paper Capacitor
L3	53851	Line cord	C11	56533	.85 mid. 400 v. Paper Capacitor
L.C.	53851	Line cord	C12	56673	#3 I.F. Trimmers (Part of Assy.)
D.L.	70535	Dial light, type 47	C13, C14	56673	#4 I.F. Trimmers (Part of Assy.)
P.M.S.	53450	5" Permanent magnet speaker	C15, C16		

TUBE	FUNCTION	Voltage of each socket prong to B- (Prong No. 3 of 12SK7)							
		No. 1	No. 2	No. 3	No. 4	No. 5	No. 6	No. 7	No. 8
12SA7	Oscillator - Converter	0	-	90	90	0	0	-	0
12SK7	I-F Amplifier	0	-	0	0	0	90	-	90
12SQ7	Detector - AVC - 1st. Audio	0	0	0	0	0	28	-	-
50L6	Beam Power Amplifier	0	-	115	90	0	0	-	6
35Z5	Rectifier	-	-	-	-	110 AC	-	-	117

MOST-OFTEN-NEEDED RADIO DIAGRAMS

SCHEMATIC DIAGRAM LEAR SUPERHETERODYNE MODEL 661 BOTTOM VIEWS OF ALL SOCKET CONNECTIONS

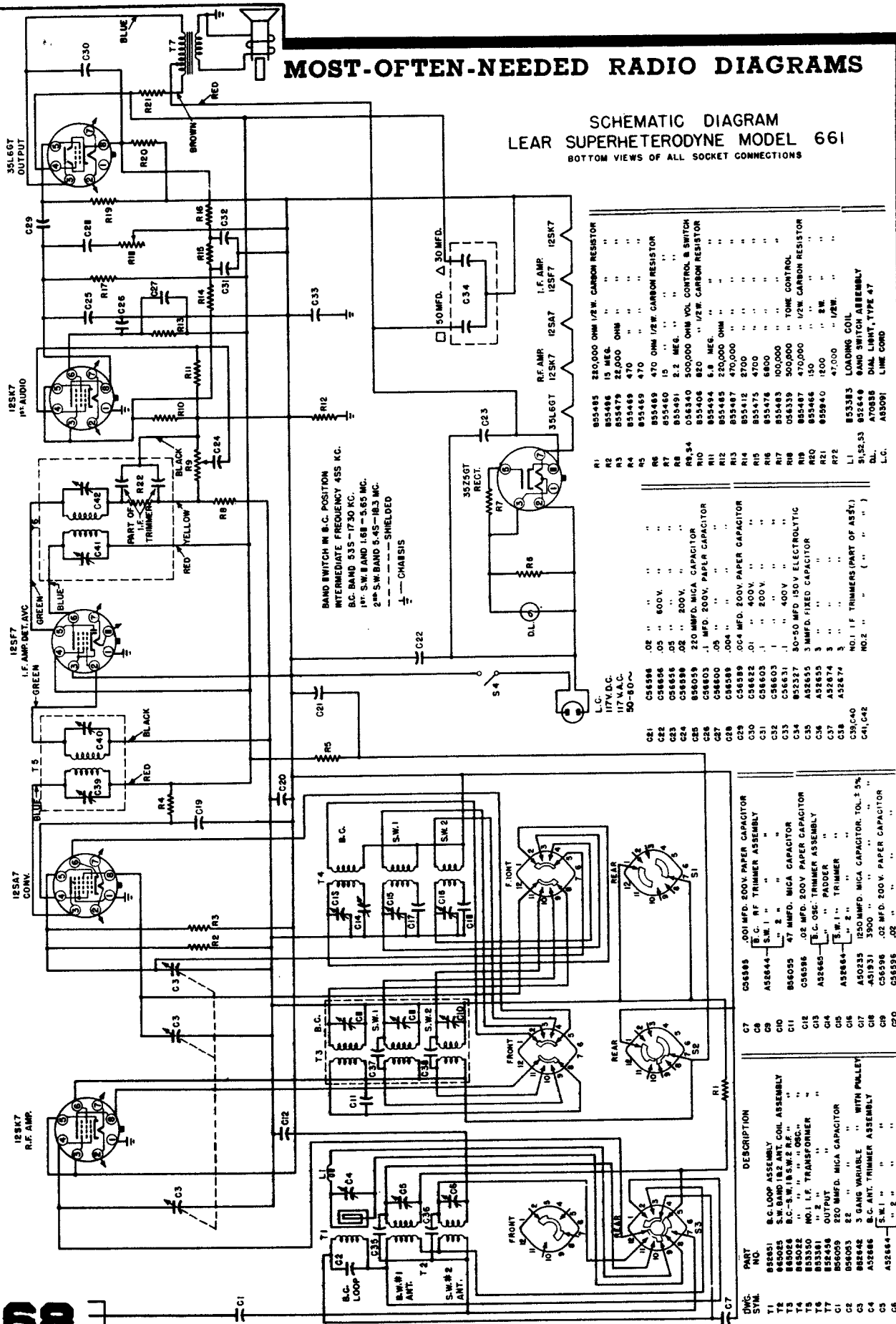

NO.	DESCRIPTION	NO.	DESCRIPTION
T1	B.C. LOOP ASSEMBLY	R1	280,000 OHM 1/2 W. CARBON RESISTOR
T2	S.W. BAND 182 ANT. COIL ASSEMBLY	R2	15 MEG.
T3	B.C. S.W. 18.5 W. 2 R.F.	R3	22,000 OHM
T4	" " " " 05C "	R4	470 "
T5	NO. 1 I.F. TRANSFORMER	R5	470 "
T6	NO. 2 I.F. TRANSFORMER	R6	470 OHM 1/2 W. CARBON RESISTOR
T7	ANT. TRANSFORMER	R7	2.2 MEG.
T8	ANT. TRANSFORMER	R8	500,000 OHM VOL. CONTROL SWITCH
T9	ANT. TRANSFORMER	R9,24	500,000 OHM VOL. CONTROL SWITCH
T10	ANT. TRANSFORMER	R10	820 "/ 1/2 W. CARBON RESISTOR
T11	ANT. TRANSFORMER	R11	5.8 MEG.
T12	ANT. TRANSFORMER	R12	250,000 OHM
T13	ANT. TRANSFORMER	R13	470,000 "
T14	ANT. TRANSFORMER	R14	2700 "
T15	ANT. TRANSFORMER	R15	4700 "
T16	ANT. TRANSFORMER	R16	6800 "
T17	ANT. TRANSFORMER	R17	100,000 "
T18	ANT. TRANSFORMER	R18	500,000 "
T19	ANT. TRANSFORMER	R19	470,000 "/ 1/2 W. CARBON RESISTOR
T20	ANT. TRANSFORMER	R20	150 "
T21	ANT. TRANSFORMER	R21	1200 SW "
T22	ANT. TRANSFORMER	R22	47,000 "/ 1/2 W. "
T23	ANT. TRANSFORMER	R23	53383 LOADING COIL
T24	ANT. TRANSFORMER	R24	532440 BAND SWITCH ASSEMBLY
T25	ANT. TRANSFORMER	R25	470888 DIAL LIGHT, TYPE 47
T26	ANT. TRANSFORMER	R26	470888 DIAL LIGHT, TYPE 47
T27	ANT. TRANSFORMER	R27	470888 DIAL LIGHT, TYPE 47
T28	ANT. TRANSFORMER	R28	470888 DIAL LIGHT, TYPE 47
T29	ANT. TRANSFORMER	R29	470888 DIAL LIGHT, TYPE 47
T30	ANT. TRANSFORMER	R30	470888 DIAL LIGHT, TYPE 47
T31	ANT. TRANSFORMER	R31	470888 DIAL LIGHT, TYPE 47
T32	ANT. TRANSFORMER	R32	470888 DIAL LIGHT, TYPE 47
T33	ANT. TRANSFORMER	R33	470888 DIAL LIGHT, TYPE 47
T34	ANT. TRANSFORMER	R34	470888 DIAL LIGHT, TYPE 47
T35	ANT. TRANSFORMER	R35	470888 DIAL LIGHT, TYPE 47
T36	ANT. TRANSFORMER	R36	470888 DIAL LIGHT, TYPE 47
T37	ANT. TRANSFORMER	R37	470888 DIAL LIGHT, TYPE 47
T38	ANT. TRANSFORMER	R38	470888 DIAL LIGHT, TYPE 47
T39	ANT. TRANSFORMER	R39	470888 DIAL LIGHT, TYPE 47
T40	ANT. TRANSFORMER	R40	470888 DIAL LIGHT, TYPE 47
T41	ANT. TRANSFORMER	R41	470888 DIAL LIGHT, TYPE 47
T42	ANT. TRANSFORMER	R42	470888 DIAL LIGHT, TYPE 47
T43	ANT. TRANSFORMER	R43	470888 DIAL LIGHT, TYPE 47
T44	ANT. TRANSFORMER	R44	470888 DIAL LIGHT, TYPE 47
T45	ANT. TRANSFORMER	R45	470888 DIAL LIGHT, TYPE 47
T46	ANT. TRANSFORMER	R46	470888 DIAL LIGHT, TYPE 47
T47	ANT. TRANSFORMER	R47	470888 DIAL LIGHT, TYPE 47
T48	ANT. TRANSFORMER	R48	470888 DIAL LIGHT, TYPE 47
T49	ANT. TRANSFORMER	R49	470888 DIAL LIGHT, TYPE 47
T50	ANT. TRANSFORMER	R50	470888 DIAL LIGHT, TYPE 47
T51	ANT. TRANSFORMER	R51	470888 DIAL LIGHT, TYPE 47
T52	ANT. TRANSFORMER	R52	470888 DIAL LIGHT, TYPE 47
T53	ANT. TRANSFORMER	R53	470888 DIAL LIGHT, TYPE 47
T54	ANT. TRANSFORMER	R54	470888 DIAL LIGHT, TYPE 47
T55	ANT. TRANSFORMER	R55	470888 DIAL LIGHT, TYPE 47
T56	ANT. TRANSFORMER	R56	470888 DIAL LIGHT, TYPE 47
T57	ANT. TRANSFORMER	R57	470888 DIAL LIGHT, TYPE 47
T58	ANT. TRANSFORMER	R58	470888 DIAL LIGHT, TYPE 47
T59	ANT. TRANSFORMER	R59	470888 DIAL LIGHT, TYPE 47
T60	ANT. TRANSFORMER	R60	470888 DIAL LIGHT, TYPE 47
T61	ANT. TRANSFORMER	R61	470888 DIAL LIGHT, TYPE 47
T62	ANT. TRANSFORMER	R62	470888 DIAL LIGHT, TYPE 47
T63	ANT. TRANSFORMER	R63	470888 DIAL LIGHT, TYPE 47
T64	ANT. TRANSFORMER	R64	470888 DIAL LIGHT, TYPE 47
T65	ANT. TRANSFORMER	R65	470888 DIAL LIGHT, TYPE 47
T66	ANT. TRANSFORMER	R66	470888 DIAL LIGHT, TYPE 47
T67	ANT. TRANSFORMER	R67	470888 DIAL LIGHT, TYPE 47
T68	ANT. TRANSFORMER	R68	470888 DIAL LIGHT, TYPE 47
T69	ANT. TRANSFORMER	R69	470888 DIAL LIGHT, TYPE 47
T70	ANT. TRANSFORMER	R70	470888 DIAL LIGHT, TYPE 47
T71	ANT. TRANSFORMER	R71	470888 DIAL LIGHT, TYPE 47
T72	ANT. TRANSFORMER	R72	470888 DIAL LIGHT, TYPE 47
T73	ANT. TRANSFORMER	R73	470888 DIAL LIGHT, TYPE 47
T74	ANT. TRANSFORMER	R74	470888 DIAL LIGHT, TYPE 47
T75	ANT. TRANSFORMER	R75	470888 DIAL LIGHT, TYPE 47
T76	ANT. TRANSFORMER	R76	470888 DIAL LIGHT, TYPE 47
T77	ANT. TRANSFORMER	R77	470888 DIAL LIGHT, TYPE 47
T78	ANT. TRANSFORMER	R78	470888 DIAL LIGHT, TYPE 47
T79	ANT. TRANSFORMER	R79	470888 DIAL LIGHT, TYPE 47
T80	ANT. TRANSFORMER	R80	470888 DIAL LIGHT, TYPE 47
T81	ANT. TRANSFORMER	R81	470888 DIAL LIGHT, TYPE 47
T82	ANT. TRANSFORMER	R82	470888 DIAL LIGHT, TYPE 47
T83	ANT. TRANSFORMER	R83	470888 DIAL LIGHT, TYPE 47
T84	ANT. TRANSFORMER	R84	470888 DIAL LIGHT, TYPE 47
T85	ANT. TRANSFORMER	R85	470888 DIAL LIGHT, TYPE 47
T86	ANT. TRANSFORMER	R86	470888 DIAL LIGHT, TYPE 47
T87	ANT. TRANSFORMER	R87	470888 DIAL LIGHT, TYPE 47
T88	ANT. TRANSFORMER	R88	470888 DIAL LIGHT, TYPE 47
T89	ANT. TRANSFORMER	R89	470888 DIAL LIGHT, TYPE 47
T90	ANT. TRANSFORMER	R90	470888 DIAL LIGHT, TYPE 47
T91	ANT. TRANSFORMER	R91	470888 DIAL LIGHT, TYPE 47
T92	ANT. TRANSFORMER	R92	470888 DIAL LIGHT, TYPE 47
T93	ANT. TRANSFORMER	R93	470888 DIAL LIGHT, TYPE 47
T94	ANT. TRANSFORMER	R94	470888 DIAL LIGHT, TYPE 47
T95	ANT. TRANSFORMER	R95	470888 DIAL LIGHT, TYPE 47
T96	ANT. TRANSFORMER	R96	470888 DIAL LIGHT, TYPE 47
T97	ANT. TRANSFORMER	R97	470888 DIAL LIGHT, TYPE 47
T98	ANT. TRANSFORMER	R98	470888 DIAL LIGHT, TYPE 47
T99	ANT. TRANSFORMER	R99	470888 DIAL LIGHT, TYPE 47
T100	ANT. TRANSFORMER	R100	470888 DIAL LIGHT, TYPE 47
C1	B.C. LOOP	C21	117 V.D.C.
C2	S.W. #1 ANT.	C22	117 V.A.C.
C3	S.W. #2 ANT.	C23	50-60 ~
C4	ANT. TRANSFORMER	C24	
C5	ANT. TRANSFORMER	C25	
C6	ANT. TRANSFORMER	C26	
C7	ANT. TRANSFORMER	C27	
C8	ANT. TRANSFORMER	C28	
C9	ANT. TRANSFORMER	C29	
C10	ANT. TRANSFORMER	C30	
C11	ANT. TRANSFORMER	C31	
C12	ANT. TRANSFORMER	C32	
C13	ANT. TRANSFORMER	C33	
C14	ANT. TRANSFORMER	C34	
C15	ANT. TRANSFORMER	C35	
C16	ANT. TRANSFORMER	C36	
C17	ANT. TRANSFORMER	C37	
C18	ANT. TRANSFORMER	C38	
C19	ANT. TRANSFORMER	C39,C40	
C20	ANT. TRANSFORMER	C41,C42	
C21	ANT. TRANSFORMER		
C22	ANT. TRANSFORMER		
C23	ANT. TRANSFORMER		
C24	ANT. TRANSFORMER		
C25	ANT. TRANSFORMER		
C26	ANT. TRANSFORMER		
C27	ANT. TRANSFORMER		
C28	ANT. TRANSFORMER		
C29	ANT. TRANSFORMER		
C30	ANT. TRANSFORMER		
C31	ANT. TRANSFORMER		
C32	ANT. TRANSFORMER		
C33	ANT. TRANSFORMER		
C34	ANT. TRANSFORMER		
C35	ANT. TRANSFORMER		
C36	ANT. TRANSFORMER		
C37	ANT. TRANSFORMER		
C38	ANT. TRANSFORMER		
C39,C40	ANT. TRANSFORMER		
C41,C42	ANT. TRANSFORMER		
C43	ANT. TRANSFORMER		
C44	ANT. TRANSFORMER		
C45	ANT. TRANSFORMER		
C46	ANT. TRANSFORMER		
C47	ANT. TRANSFORMER		
C48	ANT. TRANSFORMER		
C49	ANT. TRANSFORMER		
C50	ANT. TRANSFORMER		
C51	ANT. TRANSFORMER		
C52	ANT. TRANSFORMER		
C53	ANT. TRANSFORMER		
C54	ANT. TRANSFORMER		
C55	ANT. TRANSFORMER		
C56	ANT. TRANSFORMER		
C57	ANT. TRANSFORMER		
C58	ANT. TRANSFORMER		
C59	ANT. TRANSFORMER		
C60	ANT. TRANSFORMER		
C61	ANT. TRANSFORMER		
C62	ANT. TRANSFORMER		
C63	ANT. TRANSFORMER		
C64	ANT. TRANSFORMER		
C65	ANT. TRANSFORMER		
C66	ANT. TRANSFORMER		
C67	ANT. TRANSFORMER		
C68	ANT. TRANSFORMER		
C69	ANT. TRANSFORMER		
C70	ANT. TRANSFORMER		
C71	ANT. TRANSFORMER		
C72	ANT. TRANSFORMER		
C73	ANT. TRANSFORMER		
C74	ANT. TRANSFORMER		
C75	ANT. TRANSFORMER		
C76	ANT. TRANSFORMER		
C77	ANT. TRANSFORMER		
C78	ANT. TRANSFORMER		
C79	ANT. TRANSFORMER		
C80	ANT. TRANSFORMER		
C81	ANT. TRANSFORMER		
C82	ANT. TRANSFORMER		
C83	ANT. TRANSFORMER		
C84	ANT. TRANSFORMER		
C85	ANT. TRANSFORMER		
C86	ANT. TRANSFORMER		
C87	ANT. TRANSFORMER		
C88	ANT. TRANSFORMER		
C89	ANT. TRANSFORMER		
C90	ANT. TRANSFORMER		
C91	ANT. TRANSFORMER		
C92	ANT. TRANSFORMER		
C93	ANT. TRANSFORMER		
C94	ANT. TRANSFORMER		
C95	ANT. TRANSFORMER		
C96	ANT. TRANSFORMER		
C97	ANT. TRANSFORMER		
C98	ANT. TRANSFORMER		
C99	ANT. TRANSFORMER		
C100	ANT. TRANSFORMER		

MANUAL OF 1947 MOST-OFTEN-NEEDED RADIO DIAGRAMS

LEAR Model 661

12SK7

12SF7

12SK7

35Z5GT

ALL VOLTAGES SHOWN ARE D.C. MEASUREMENTS TAKEN FROM B-WITH A 1000 OHM PER VOLT METER. SET OPERATING ON 117V, 60~ WITH VOLUME CONTROL ON FULL AND BAND SWITCH IN BC. POSITION. ALLOW ± 10% ON ALL MEASUREMENTS.

12SA7

35L6GT

ALIGNMENT

ALIGNMENT OF	GENERATOR CONNECTED TO	DUMMY ANTENNA	GENERATOR FREQUENCY	BAND SWITCH SETTING	DIAL AND CONDENSER SETTING	TRIMMER	REMARKS
Set dial pointer to last mark at low frequency end of dial with gang condenser closed.							
2nd. IF	12SA7	.05 mf	455 KC	BC	open	C41 & C42	Max. Output
1st. IF	Grid & B-		1500 KC		1500 KC	C39 & C40	Max. Output
BC	Ant. lead and B-	200 mmf.	600 KC	BC	600 KC	C13, C8, C4	Max. Output
						C14	Osc. Padder
Repeat operations 4 and 5 until alignment frequencies fall on correct calibration points.							
SW 1	Ant. lead and B-	400 ohms (res.)	5 MC	1	5 MC	C15, C9, C5	Max. Output
			1800 KC		1800 KC		**
SW 2	Ant. lead and B-	400 ohms (res.)	16 MC	2	16 MC	C16*, C10, C6	Max. Output
			6 MC		6 MC		**

* Rock dial while trimming C16 at 16 MC

** check sensitivity and dial calibration

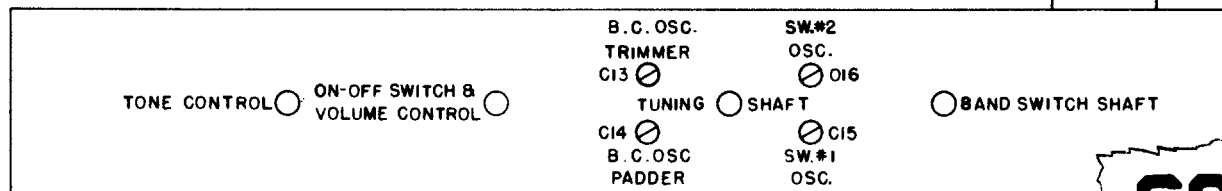
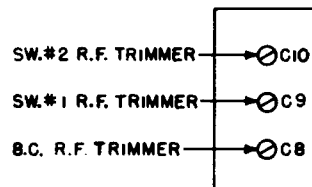
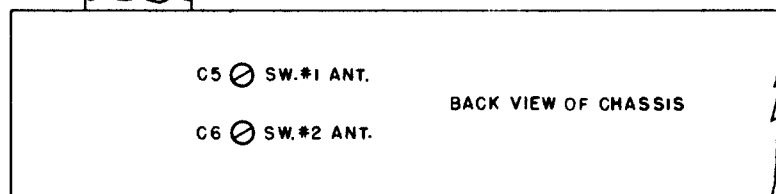
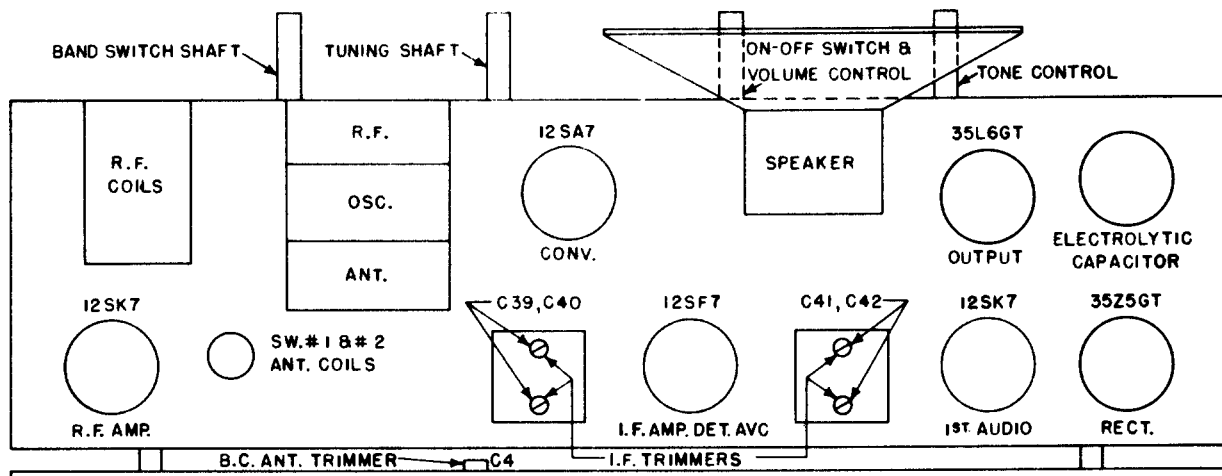

LEAR SUPERHETERODYNE MODELS 6614, 6615, 6616, 6619

BOTTOM VIEWS OF ALL SOCKET CONNECTIONS

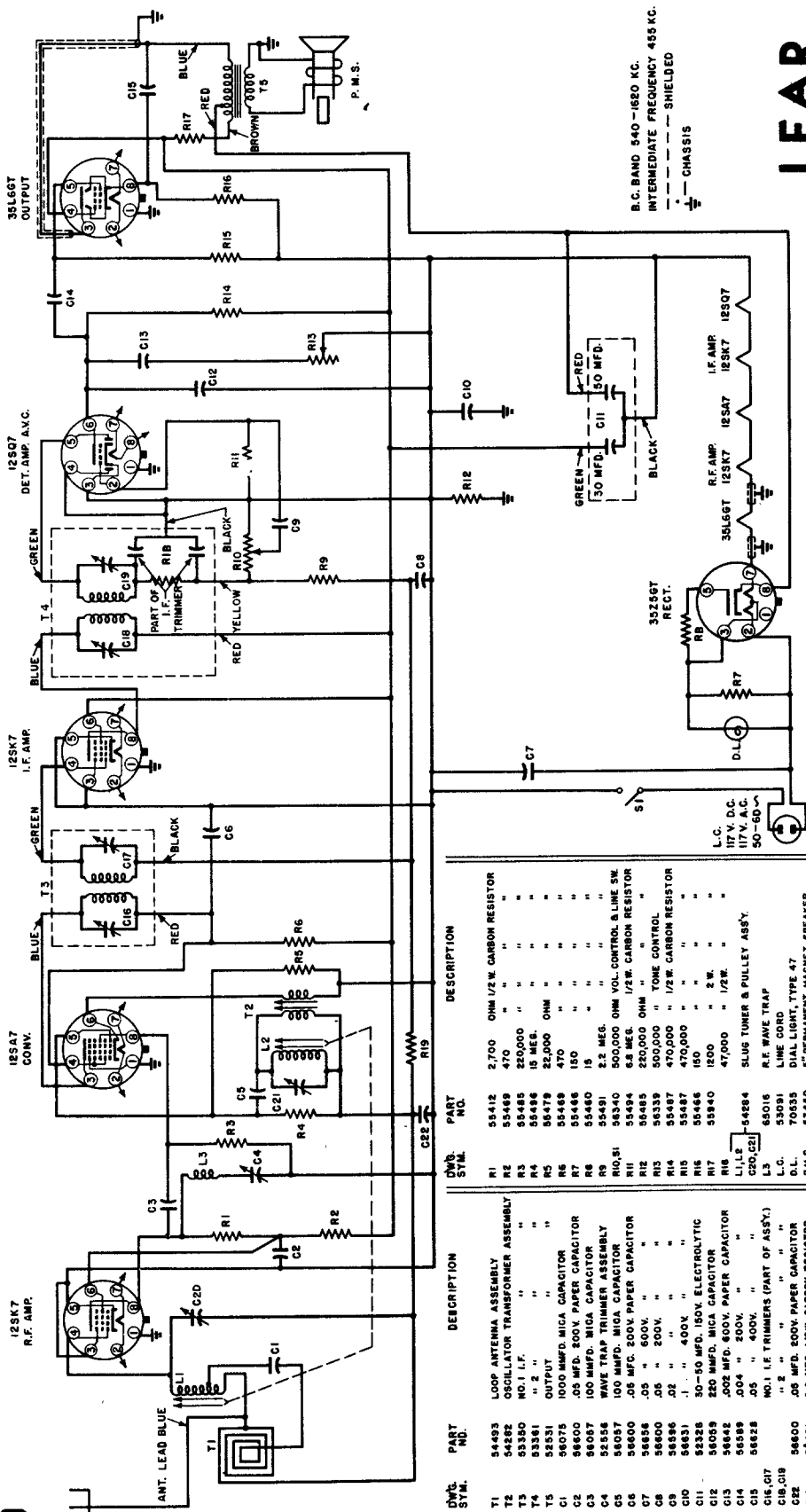

B.C. BAND 540-1650 KC.
INTERMEDIATE FREQUENCY 455 KC.
----- SHIELDED
⊥ CHASSIS

LEAR

I.F. 455 KC.

TUBE	Voltage of each socket prong to B- (Prong No. 3 of 12SK7 IF Tube)							
	No. 1	No. 2	No. 3	No. 4	No. 5	No. 6	No. 7	No. 8
12SK7	0	0	0	0	0	81	0	53
12SA7	0	0	83	82	7	0	0	0
12SK7	0	0	0	0	0	84	0	84
12SQ7	0	6	0	0	0	38	0	0
35L6GT	0	0	110	84	0	0	0	4
35Z5GT					108AC			117

MANUAL OF 1947 MOST-OFTEN-NEEDED RADIO DIAGRAMS

Models 8S452, 8S473
CHASSIS 4810

Majestic

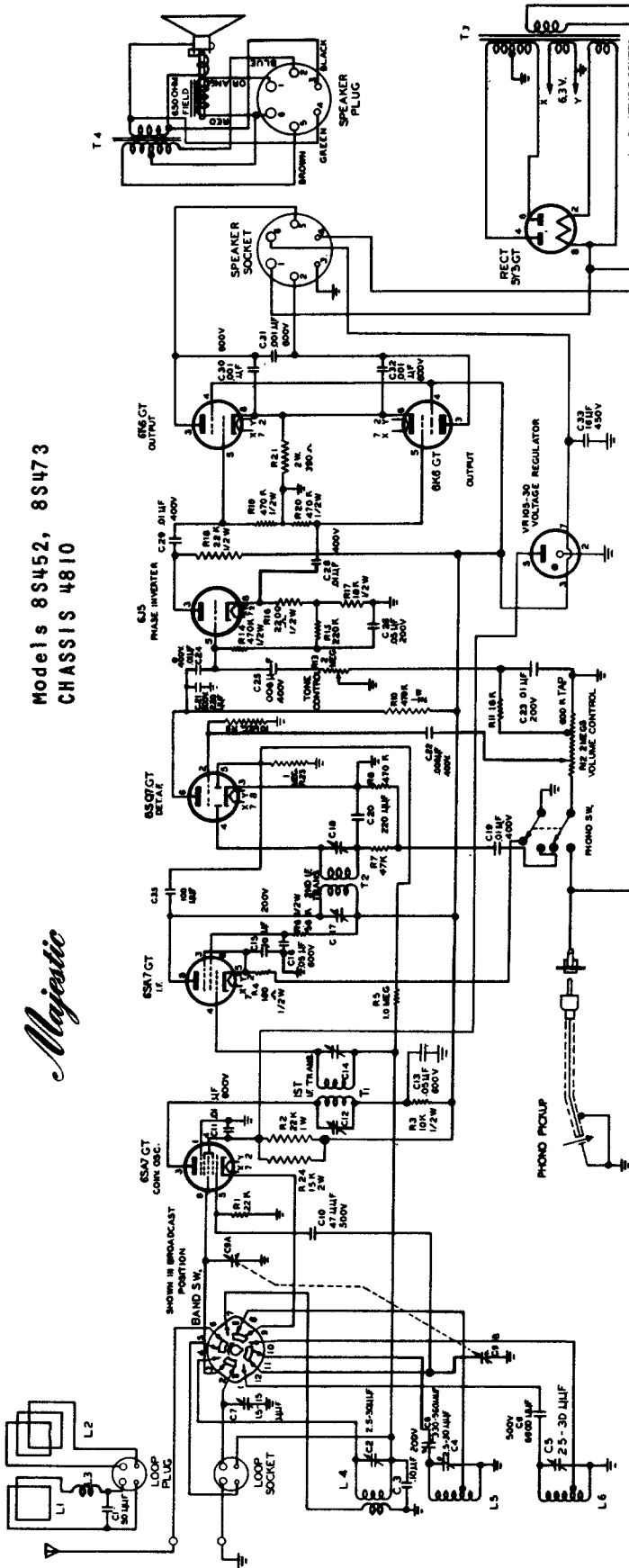

Tube	Plate	Screen	Grid
6SA7 (Conv)	240-265	105	0
6SK7 (I.F.)	282-296	106-122	2.1 - 2.5
6S7 (A.F.)	72-84	-	0
6J5 (Ph. Inv.)	208-220	-	6.0 - 7.5
6K6 (Out)	270-280	280-285	22.5 - 24
VR-105	105	-	-

When permanent magnet speakers are used, Model S-1200 filter box is added to circuit.

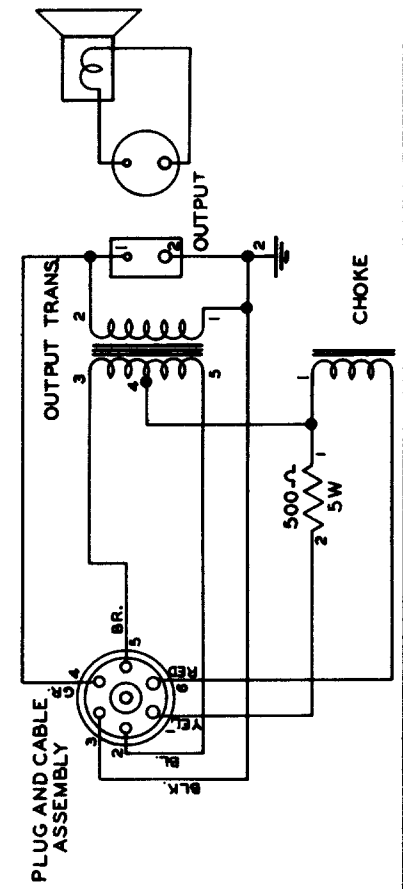

NOTE: All voltages measured to ground with 1,000 ohm per volt meter.

MANUAL OF 1947 MOST-OFTEN-NEEDED RADIO DIAGRAMS

Majestic

Models 8S452, 8S473
CHASSIS 4810

ALIGNMENT

Before aligning, close tuning condenser (plates fully meshed). Set pointer to center of extreme left hand mark on the dial.

When aligning broadcast band, connect to output of the signal generator a loop, about 12 inches in diameter, consisting of two or three turns of wire. Place this loop in a plane parallel to that of the receiver loop antenna and about a foot away from it. The receiver loop antenna should be in about the same position relative to the chassis as it is when installed in the cabinet.

While aligning, turn the volume control full on and keep the signal generator output as low as possible.

Step	Dummy Antenna	Test Oscillator Connection	Test Oscillator Frequency	Receiver Bandswitch	Receiver Dial	Adjust for Maximum	Notes
1	.01 mfd	6SA7 grid	455 kc	B. C.	Any quiet spot	C18, C17 C14, C12	
2	Loop	-	1500 kc	B. C.	150	C4, C7	
3	Loop	-	600 kc	B. C.	60	C8	Note #1
4	400 ohms	Receiver antenna post	17 mc	S. W.	17	C2, C5	

Note #1 - Rock gang while making this adjustment. Then recheck step 2.

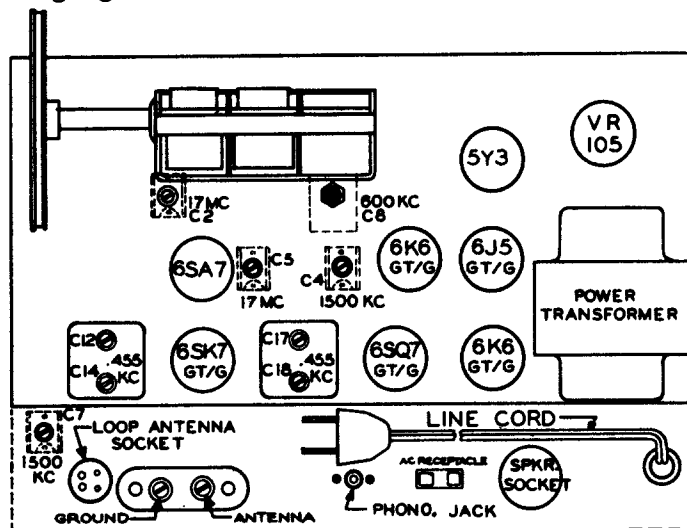

TUBE LAYOUT

MANUAL OF 1947 MOST-OFTEN-NEEDED RADIO DIAGRAMS

Before aligning, make sure that the dial pointer is exactly horizontal when the tuning condenser is closed (plates fully meshed). While aligning the receiver, turn the volume control full on and keep the signal generator output as low as possible, to prevent AVC action and false readings.

Band-switch positions are extreme right for Broadcast, center for 3.6 to 8.5 mc., extreme left for 8.5 to 19 mc.

STEP	DUMMY ANT.	TEST. OSC. CONNECTION	TEST. OSC. FREQUENCY	RECEIVER BANDSWITCH	RECEIVER DIAL	ADJUST IN ORDER SHOWN	NOTES
1	.01 mfd	1L06 grid (pin 6)	455 KC.	Right	Any Quiet Spot	T8, T7	#1
2	200 mmfd	ANT. post	600 KC.	Right	.6	"C"	#2
3	200 mmfd	ANT. post	1400 KC.	Right	1.4	Osc. Trimmer	
4	200 mmfd	ANT. post	1400 KC.	Right	1.4	Osc. Trimmer	
5	400 ohms	ANT. post	4 MC.	Center	4	Ant. Trimmer	#3
6	400 ohms	ANT. post	8 MC.	Center	8	"B"	#2
7	400 ohms	ANT. post	8 MC.	Center	8	R.F. Trimmer	#4
8	400 ohms	ANT. post	9 MC.	Left	9	"A"	#2
9	400 ohms	ANT. post	18 MC.	Left	18	Osc. Trimmer	#4
10	400 ohms	ANT. post	18 MC.	Left	18	R.F. Trimmer	

NOTE #1 - Ground oscillator grid (1L06 pin 4) while adjusting I.F. transformers.

NOTE #2 - "Rock" tuning gang while making this adjustment.

NOTE #3 - Carefully repeat steps 1 through 4.

NOTE #4 - When making short wave oscillator adjustments, take great care to see that alignment is not made on the image. When the trimmer is correctly adjusted, a weaker peak will be noticed at a receiver dial adjustment which is 910 KC lower than the aligning frequency.

MAJESTIC
MODELS G1-426, G1-426Y
CHASSIS 4807, 4808

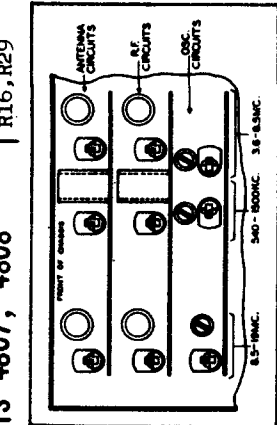
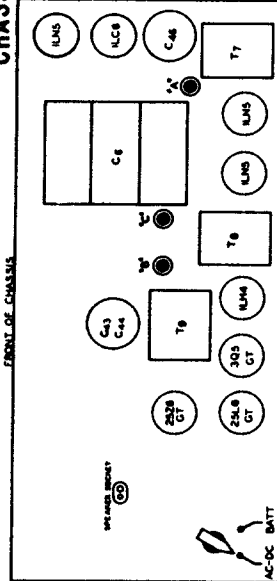

ITEM DESCRIPTION

- C1, C28, C30, C48
- C2, C8
- C3, C9, C10, C38, C39, C40
- C4, C5, C11
- C6A, C6B, C6C
- C7
- C12, C13, C21, C25, C31, C49
- C14
- C15
- C16, C23
- C17, C19
- C18
- C20
- C22
- C24
- C26, C27, C41
- C29
- C33, C45
- C35
- C36
- C37
- C46

- .006 mfd +20% 600 v molded paper
- .05 mfd +20% -10% 200 v molded paper
- Ceramic Trimmer 7-35 mmfd
- Ceramic Trimmer 34-72 mmfd
- Variable, 3 gang
- 15 mmfd +20% 500 v fixed ceramic
- .1 mfd +40% -10% 400 v molded paper
- .0022 mfd 10% 500 v mica
- 150 mmfd 5% 500 v mica
- 82 mmfd 5% 500 v mica
- .02 mfd +40% -10% 200 v molded paper
- .01 mfd +20% -10% 400 v molded paper
- 220 mmfd 20% 400 v fixed ceramic
- 51 mmfd 5% 500 v mica
- .05 mfd +40% -10% 600 v molded paper
- 100 mmfd 20% 500 v molded mica
- 470 mmfd 20% 500 v molded paper
- .01 mfd +40% -10% 600 v molded paper
- 40-40 mfd 250 v dual electrolytic
- 430 mmfd 2% 500 v molded mica
- 2200 mmfd 5% 500 v molded mica
- .003 mfd 5% 500 v molded mica
- 1000 mfd 15 v electrolytic
- Phone jack
- Line filter choke coil
- R.F. choke
- Speaker, P.M. 6"
- Speaker receptacle
- Speaker plug
- 270 ohm 10% 1/2 watt carbon
- 3.3 megohms 10% 1/2 watt carbon
- 3.9 megohms 10% 1/2 watt carbon
- 220,000 ohm 20% 1/2 watt carbon
- 68,000 ohm 10% 1/2 watt carbon
- 1,000 ohm 20% 1/2 watt carbon
- 22,000 ohm 10% 1/2 watt carbon
- 470,000 ohm 20% 1/2 watt carbon
- 47,000 ohm 20% 1/2 watt carbon
- 330 ohm 10% 1/2 watt carbon
- 1 megohm 20% variable with switch
- 100,000 ohm 20% 1/2 watt carbon
- 470,000 ohm 10% 1/2 watt carbon
- 62 ohm 5% 1/2 watt carbon
- 10 ohm 20% 1/2 watt carbon
- 220 ohms 5% 30 watt wirewound
- 43 ohm 5% 8 watt wirewound
- 2200 ohm 10% 1/2 watt carbon
- 260 ohm 5% 60 watt wirewound
- 4700 ohm 10% 1/2 watt carbon
- 820 ohm 10% 1/2 watt carbon
- 27 ohm 10% 1/2 watt carbon
- 12 megohms 10% 1/2 watt carbon

- J1
- L1
- L2
- LS1
- S01
- PL1
- R2
- R3, R8, R10
- R4
- R5
- R6
- R7, R13
- R9, R11
- R12, R15, R18
- R14
- R16, R29
- R17
- R19
- R20
- R21
- R22
- R23
- R24
- R25
- R26
- R27
- R28
- R30
- R31

1947 MOST-OFTEN-NEEDED RADIO DIAGRAMS

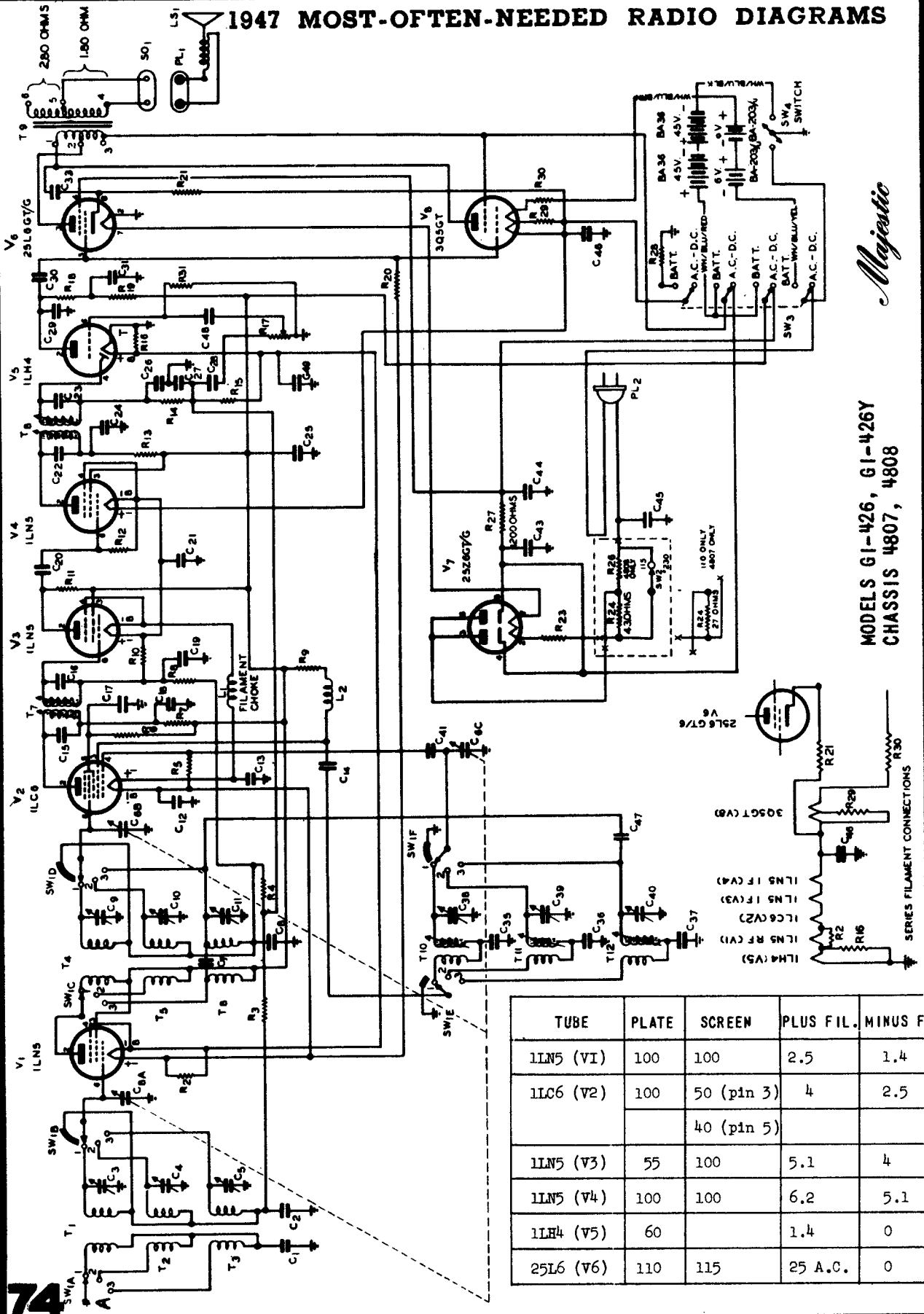

Majestic

MODELS GI-426, GI-426Y
CHASSIS 4807, 4808

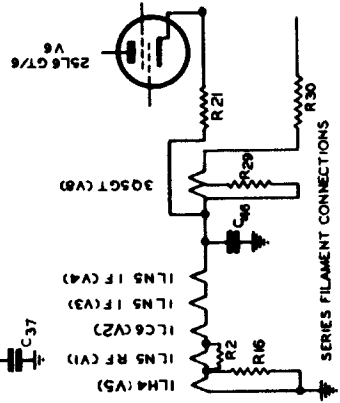

TUBE	PLATE	SCREEN	PLUS FIL.	MINUS F
11N5 (V1)	100	100	2.5	1.4
11C6 (V2)	100	50 (pin 3)	4	2.5
		40 (pin 5)		
11N5 (V3)	55	100	5.1	4
11N5 (V4)	100	100	6.2	5.1
11LH4 (V5)	60		1.4	0
25L6 (V6)	110	115	25 A.C.	0

1947 MOST-OFTEN-NEEDED RADIO DIAGRAMS

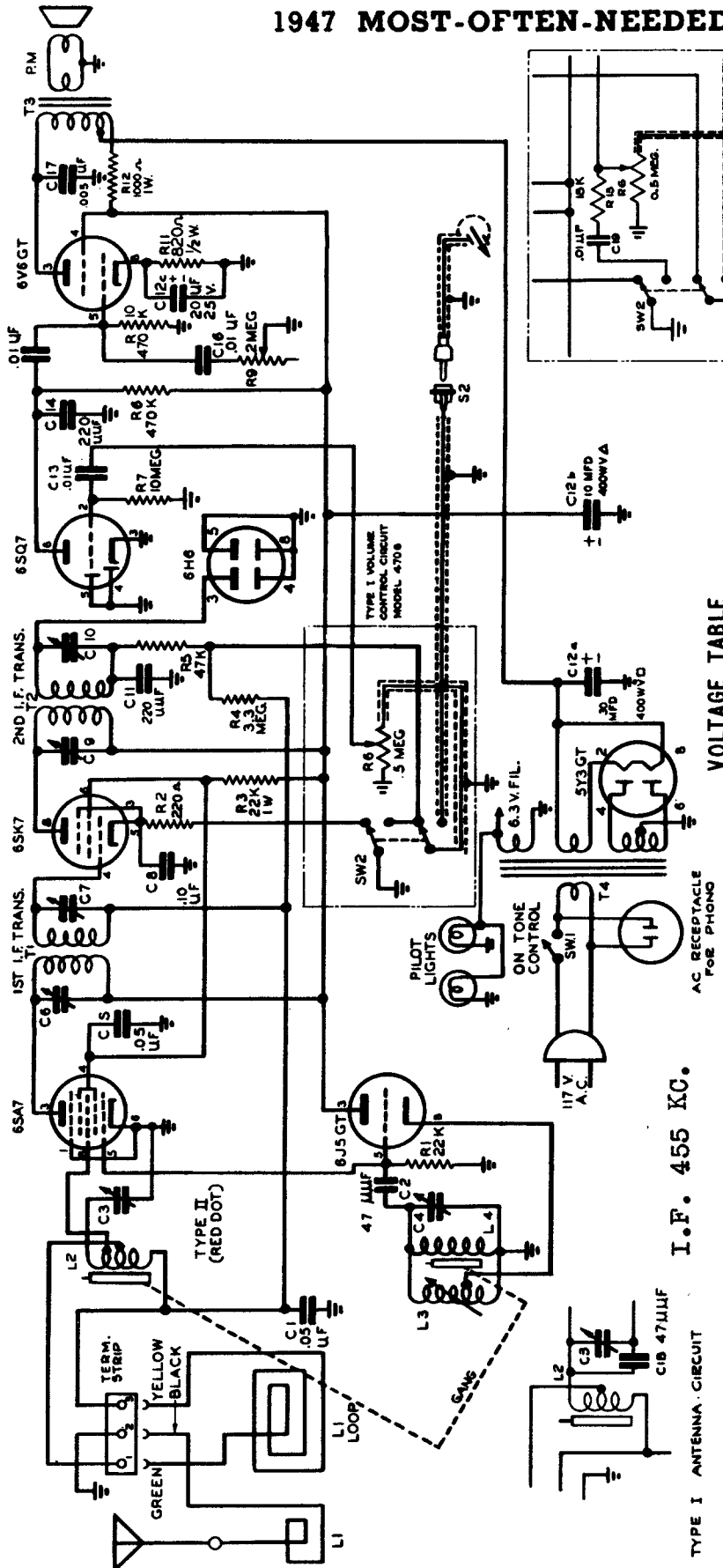

TYPE I ANTENNA CIRCUIT I.F. 455 KC.

VOLTAGE TABLE

TUBE	PLATE	SCREEN	CATHODE
6SA7 (CONV.)	244	74	--
6J5 (OSC.)	244	--	--
6SK7 (I.F.)	244	74	1.6
6SQ7 (A.F.)	75		
6V6 (OUT)	268	243	11

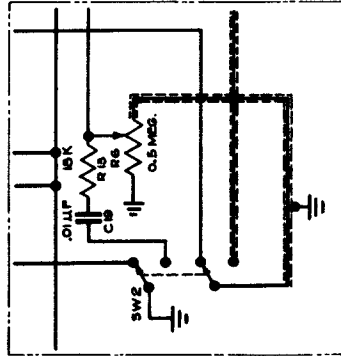

TYPE II VOLUME CONTROL CIRCUIT MODELS 4707, 4708

Majestic

MODELS 7C432, 7C447
CHASSIS 4706, 4707, 4708.

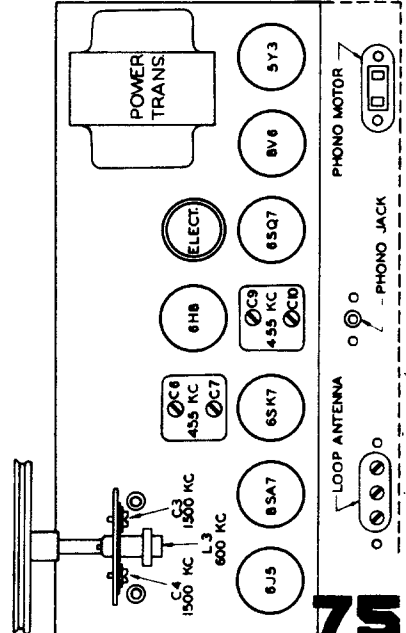

MANUAL OF 1947 MOST-OFTEN-NEEDED RADIO DIAGRAMS

McMurdo Silver Co., Inc.



PARTS LIST

- D.C. volts 3, 12, 30, 120, 300 and 1200 at 51 megohms constant input resistance (1 megohm in capacity-isolating test prod). Same six ranges in reverse polarity by shift of FUNCTION knob. Accuracy $\pm 3\%$.
- D.C. volts 7.5, 30, 75, 300, 750 and 3000 at 126 megohms constant input resistance (obtained at $\sqrt{x2.5}$ and COM-GND jacks). Same six ranges in reverse polarity by shift of FUNCTION knob. Accuracy $\pm 3\%$.
- A.C. volts 3, 12, 30, 120, 300 and 1200 volts at circuit loading equivalent to 6.6 megohms shunted by 50 mmfd. (diode probe plugged into panel socket). Accuracy $\pm 5\%$.
- R.F. volts same as A.C. volts but at circuit loading equivalent to 6.6 megohms shunted by 8 mmfd. (diode probe withdrawn for direct contacting to circuit to be measured). Accuracy $\pm 5\%$.
- OHMS: Six resistance ranges, all zero-left, of 2,000, 20,000, 200,000 ohms and 2, 20 and 2,000 megohms. Accuracy $\pm 2\%$ of full scale, $\pm 1\%$ of indicated resistance.
- DECIBELS: Three db. ranges (0 db. = 1 milliwatt in 600 ohms) of -10/+10, +10/+30 and +30/+50 db.
- CURRENT: Six direct current ranges of 1.2, 30, 120, 300 1200 milliamperes and 12 amperes.

- C1 — 0.0005-ufd. silver-mica
- C2 — 0.001-ufd. mica
- C3 — 0.03-ufd. 3000-volt tubular oil
- C4 — 0.005-ufd. mica
- C5, C6 — 8-ufd. 350-volt electrolytic
- R1 — 20-megohm, ± 5 per cent, $\frac{1}{4}$ -watt carbon resistor
- R2, R9 — 7.5 megohms, $\frac{1}{2}$ watt metalized resistors*
- R3 — 1.5 megohms, $\frac{1}{2}$ watt metalized resistors*
- R4, R11 — 750,000 ohms, $\frac{1}{2}$ watt metalized resistors*
- R5 — 250,000 ohms $\frac{1}{2}$ watt metalized resistors*
- R6, R7, R8 — 37.5 megohms, — watt metalized resistors*
- R10 — 3.75 megohms, $\frac{1}{2}$ watt metalized resistors*
- R12 — 375,000 ohms, $\frac{1}{2}$ watt metalized resistors*
- R13 — 125,000 ohms, $\frac{1}{2}$ watt metalized resistors*
- R14 — 10-ohm, 1 per cent $\frac{1}{2}$ watt wire-wound
- R15 — 100 ohms, $\frac{1}{2}$ watt metalized resistors*
- R16 — 1,000 ohms, $\frac{1}{2}$ watt metalized resistors*
- R17 — 10,000 ohms, $\frac{1}{2}$ watt metalized resistors*
- R18 — 100,000 ohms, $\frac{1}{2}$ watt metalized resistors*
- R19 — 10 megohms, $\frac{1}{2}$ watt metalized resistors*
- R20, R21, R41 — 5.1 megohm, ± 5 per cent, $\frac{1}{2}$ watt metalized
- R22, R23, R24, R25, R26 — 3000 ohm wire-wound potentiometer
- R-27 — 258.4 ohm, 1 per cent wire-wound resistor
- R28 — 1.758 ohm, 1 per cent wire-wound resistor
- R29 — 0.423 ohm, 1 per cent wire-wound resistor
- R30 — 0.161 ohm, 1 per cent wire-wound resistor
- R31 — 0.028 ohm, 1 per cent wire-wound resistor
- R32 — Special-Set in test to give 12-ampere range
- R33 — 10,000 ohm, wire-wound potentiometer with s.p.s.t. switch
- R34 — 3000 ohm wire-wound potentiometer
- R35, R36, R37, R40 — 43,000 ohms, ± 5 per cent, 2 watt
- R38, R39 — 4,300 ohm, ± 5 per cent, $\frac{1}{2}$ watt metalized resistors.
- R42 — 10 megohm potentiometer
- S1 — 5-position, 6-circuit, 3-section ceramic switch
- S2 — 5-circuit, 6-position, 5-section ceramic switch (front section shorting)
- T — Power Transformer; 115-volt, 50/60 primary; 5-volts, 2 amp.; 6.3 volts, 1.6 amp.; 640 volts, 50 ma.

*Pairs of I.R.C. BT- $\frac{1}{2}$ resistors matched in series to give specified values.

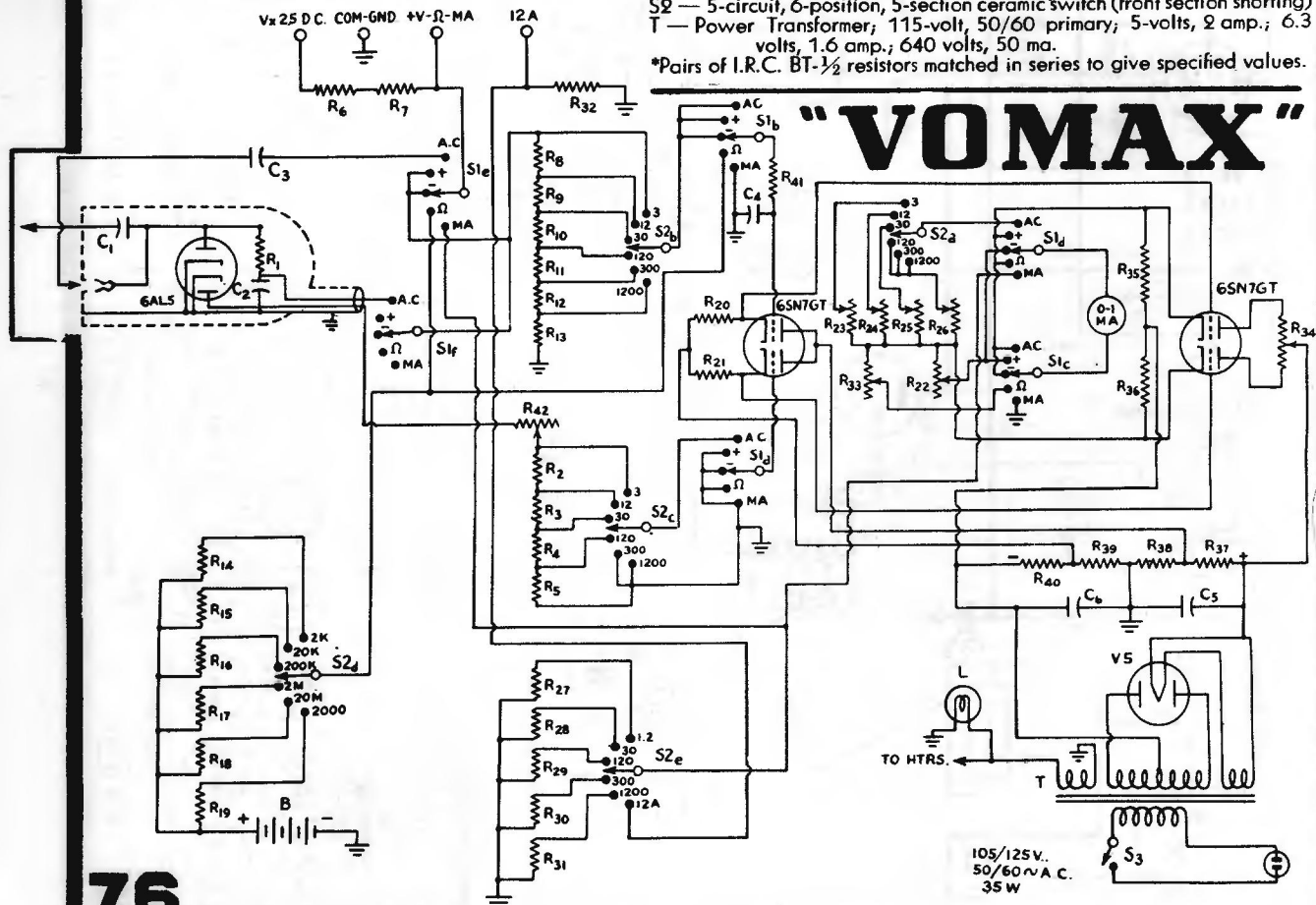

105/125V.
50/60 A.C.
35 W

MANUAL OF 1947 MOST-OFTEN-NEEDED RADIO DIAGRAMS

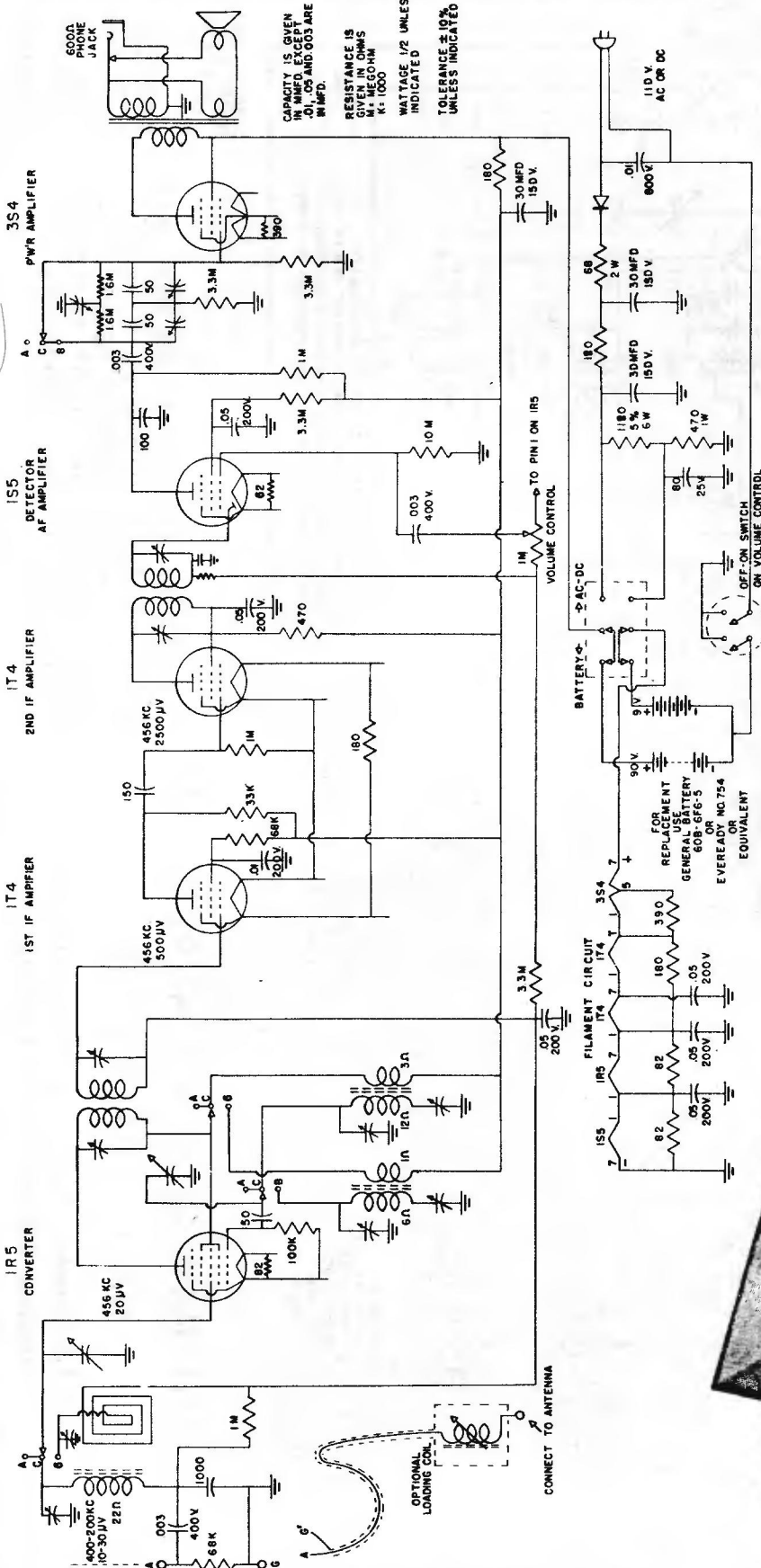

CAPACITY IS GIVEN IN MMFD EXCEPT .01, .05 AND .005 ARE IN μ FD.
RESISTANCE IS GIVEN IN OHMS M. MEGOHM K. 1000
WATTAGE 1/2 UNLESS INDICATED
TOLERANCE $\pm 10\%$ UNLESS INDICATED

ALIGNMENT. A VVM should be used to read avc voltage when aligning this receiver; for 50 milliwatts audio avc voltage is approximately 0.6. The schematic shows various sensitivities which can be used to trace any lack of gain.

Connection	Signal Band	Dial Adjustment
Through .05 mfd to converter grid.	B 1000 KC	Peak 1st and 3rd IF transformer trimmers.
Through 50 mfd. to antenna post	C 400 KC	Peak C RF and Oscillator trimmers.
	C 200 KC	Peak C oscillator padder.
None		Use local stations at either end. Peak B oscillator padder on low end and peak B RF and oscillator trimmers at the high end.

MIDWEST MODEL P-6, PB-6

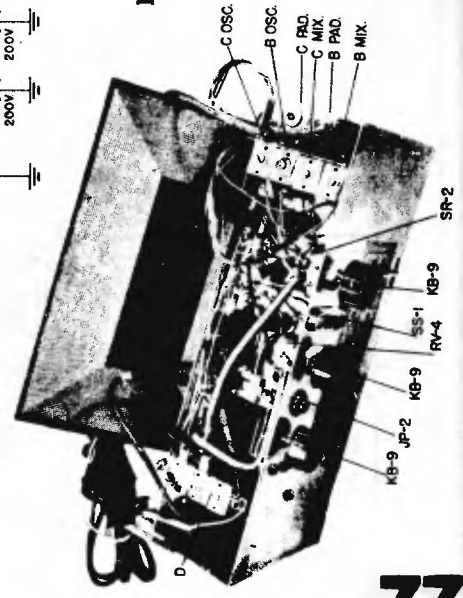

MANUAL OF 1947 MOST-OFTEN-NEEDED RADIO DIAGRAMS

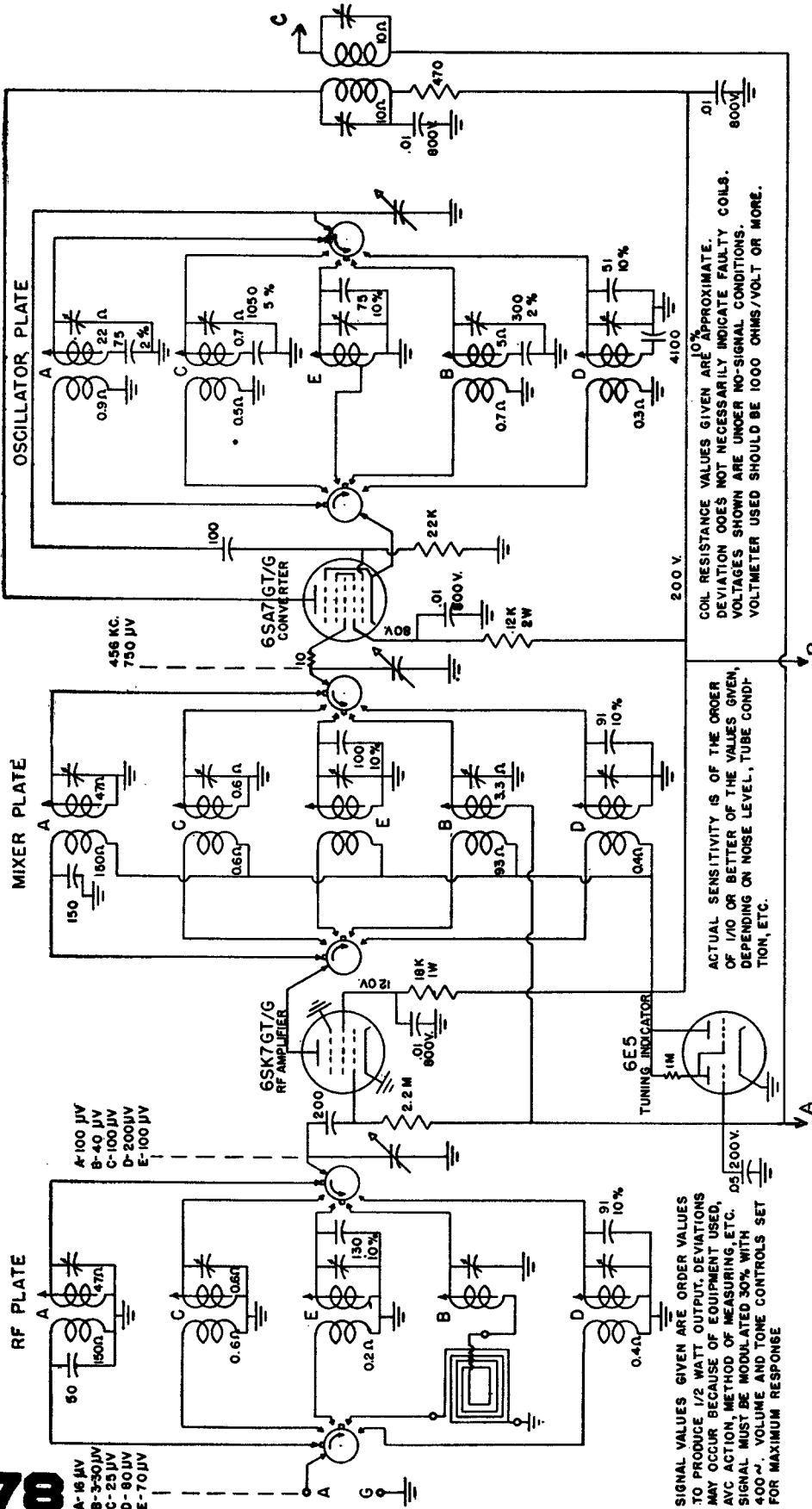

CAPACITY IS GIVEN IN MMFD. EXCEPT .01, .02 & .05 ARE MFD.

RESISTANCE IS GIVEN IN OHMS * = 1000 OHMS

WATTAGE IS 1/2 EXCEPT WHERE INDICATED

TOLERANCE IS $\pm 20\%$ UNLESS INDICATED

Balance of circuit is on the next page. Points marked A, B, and C, connect to corresponding points. Where applicable, notes apply to both parts of the schematic.

MIDWEST SERIES 8 SUPER AM RADIO RECEIVER

1947 Models - S-8, ST-8, TM-8 and other Midwest Models using STM-8 Chassis

MANUAL OF 1947 MOST-OFTEN-NEEDED RADIO DIAGRAMS

ALIGNMENT — The schematic includes the various signal strengths necessary for standard output of 0.5 watt. The output indicator may be an audio frequency meter across the voice coil or a vacuum tube voltmeter at the avc. For 0.5 watt the voltage at the voice coil is 1.2 volts or 2.5 to 3.5 volts avc. if a 30% modulated signal is used. I.F. alignment should be made with band switch on "B," pointer tuned to 1000 kc. and signal to mixer grid through a .05 mfd. condenser. Trim both I.F. transformers for maximum reading.

R. F. alignment should be made in the usual manner. There is no inter-action between bands. The only precaution is that a dummy antenna be used between the generator and the antenna post on the receiver. This may be simply a 200 micro micro farad condenser in series with a 400 ohm resistor. The B band RF paddler, 550 KC, is very broad and should not be adjusted. The loop must be plugged in when adjusting the B band RF trimmer, 1600 kc.

Coupling	Signal	Band Switch	Dial	Adjustment
To converter grid thru .05 mfd capacitor	456 KC	B	1000 KC	Peak 1st and 2nd IF trimmers.
To "A" on antenna-ground terminal strip through 200 mmfd. and 400 ohms in series.	400 KC	A	400 KC	Peak RF, converter and oscillator trimmers marked "A".
	150 KC	A	150 KC	Peak RF, converter and oscillator cores marked "A".
	1600 KC	B	1600 KC	Peak "B" trimmers. Loop must be plugged in.
	550 KC	B	550 KC	Peak "B" cores except RF. Loop must be plugged in.
	4.7 MC	C	4.7 MC	Peak "C" trimmers.
	1.6 MC	C	1.6 MC	Peak "C" cores.
	10 MC	D	10 MC	Peak "D" trimmers.
	5 MC	D	5 MC	Peak "D" cores.
	22 MC	E	22 MC	Peak "E" trimmers.
	11.5 MC	E	11.5 MC	Peak "E" cores.

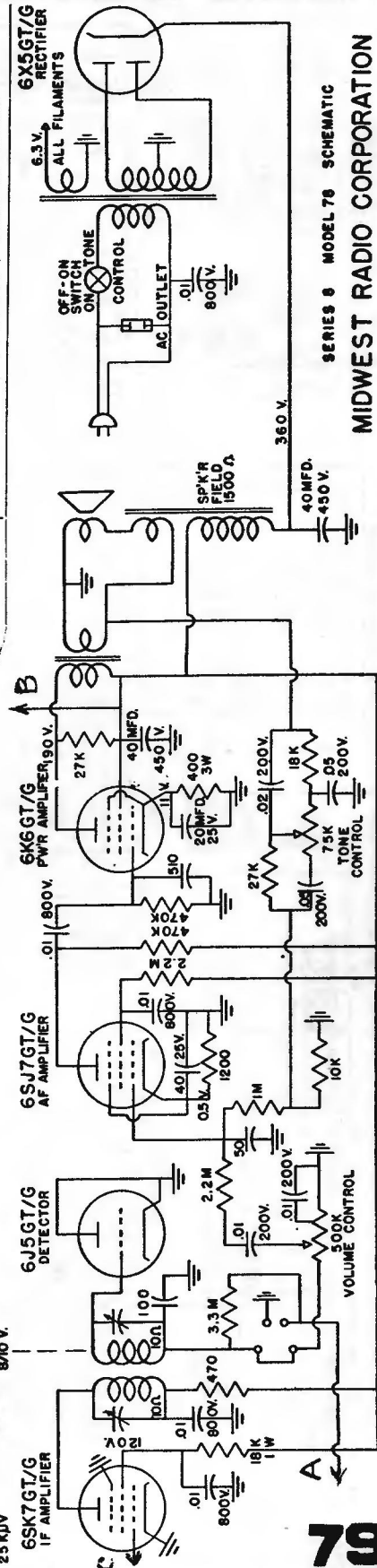
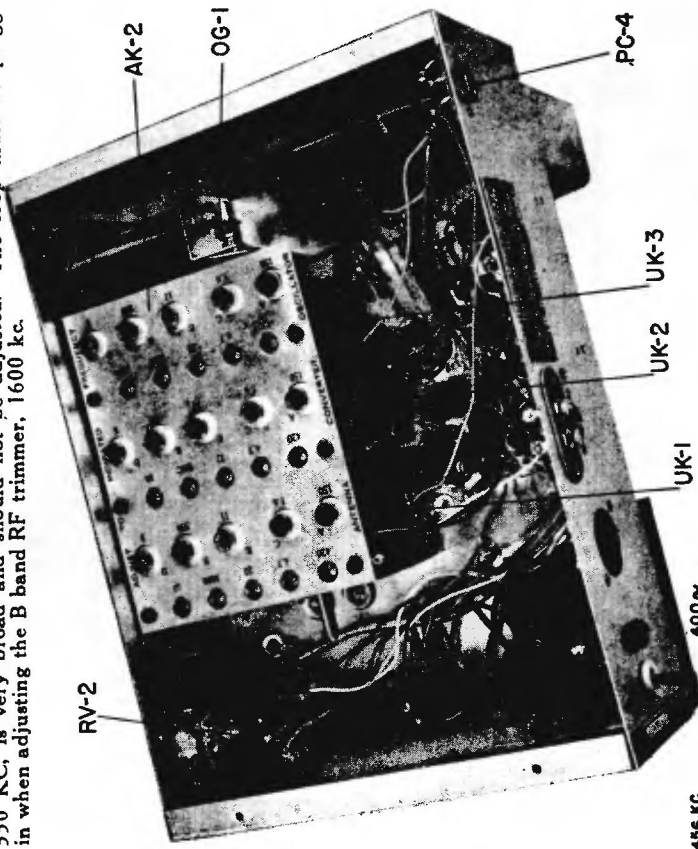

SERIES 8 MODEL 78 SCHEMATIC
MIDWEST RADIO CORPORATION

MANUAL OF 1947 MOST-OFTEN-NEEDED RADIO DIAGRAMS

CAPACITY IS GIVEN IN MFD EXCEPT WHERE INDICATED OTHERWISE.
RESISTANCE IS GIVEN IN OHMS, K = 1000 OHMS.
WATTAGE IS 1/2 EXCEPT WHERE INDICATED.
TOLERANCE IS ±20% UNLESS INDICATED.

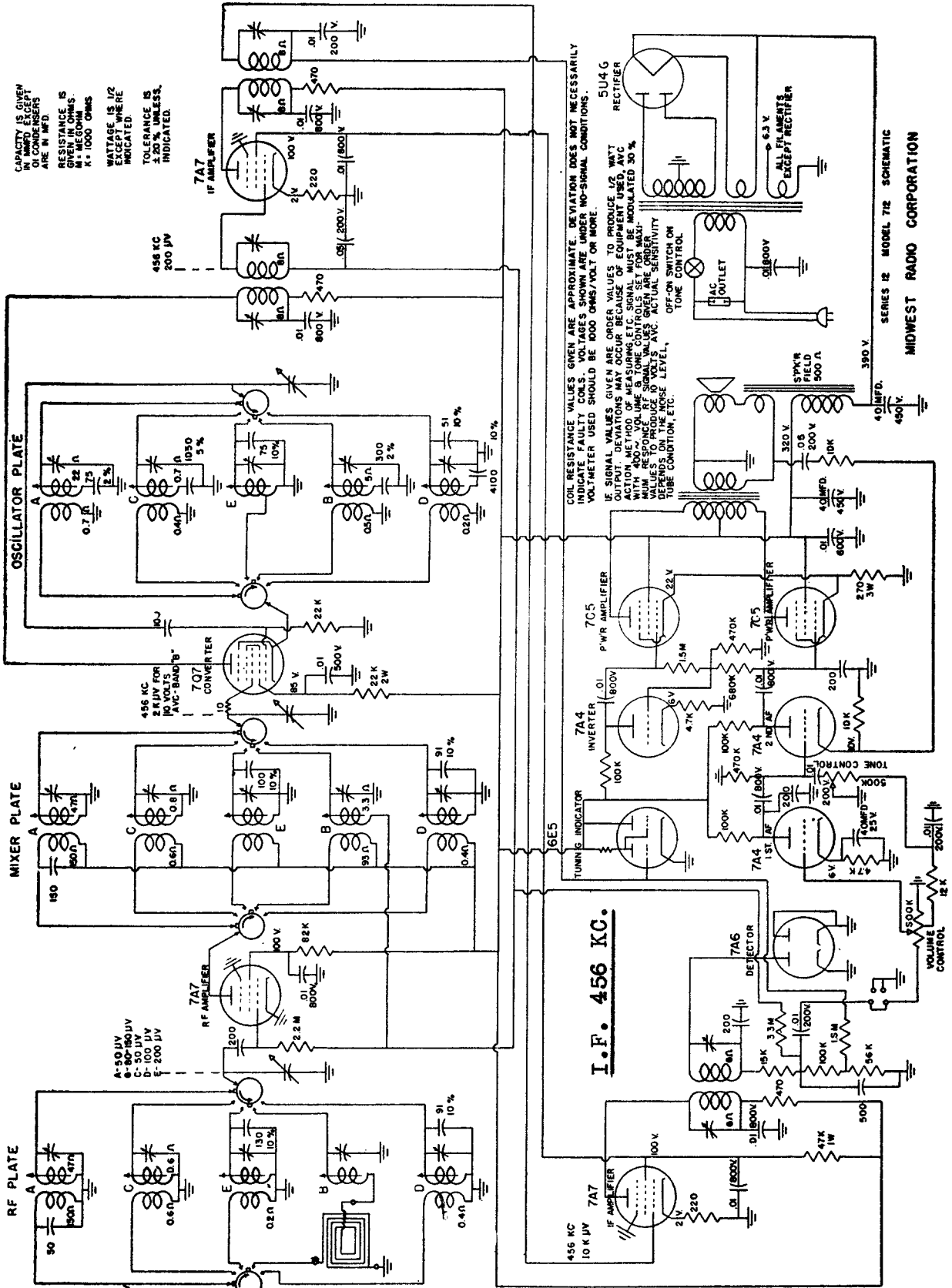

COIL RESISTANCE VALUES GIVEN ARE APPROXIMATE. DEVIATION DOES NOT NECESSARILY INDICATE FAULTY COILS. VOLTAGES SHOWN ARE UNDER NO-SIGNAL CONDITIONS.
IF SIGNAL VALUES GIVEN ARE ORDER VALUES TO PRODUCE 1/2 WATT OUTPUT. DEVIATIONS MAY OCCUR BECAUSE OF EQUIPMENT USED. AVC ACTION METHOD OF MEASURING ETC. SIGNAL MUST BE MODULATED 30% MIN. IN RESPONSE TO SIGNALS. COILS FOR MAXIMUM ACTUAL SENSITIVITY VALUES TO PRODUCE 10 VOLTS AVC. ACTUAL SENSITIVITY TUBE CONDITION ETC. LEVEL, TONE CONTROL, OFF-ON SWITCH ON TONE CONTROL.

IF SIGNAL VALUES GIVEN ARE ORDER VALUES TO PRODUCE 1/2 WATT OUTPUT. DEVIATIONS MAY OCCUR BECAUSE OF EQUIPMENT USED. AVC ACTION METHOD OF MEASURING ETC. SIGNAL MUST BE MODULATED 30% MIN. IN RESPONSE TO SIGNALS. COILS FOR MAXIMUM ACTUAL SENSITIVITY VALUES TO PRODUCE 10 VOLTS AVC. ACTUAL SENSITIVITY TUBE CONDITION ETC. LEVEL, TONE CONTROL, OFF-ON SWITCH ON TONE CONTROL.

SERIES 12 MODEL 72 SCHEMATIC
MIDWEST RADIO CORPORATION

WARDS

MODELS 54 WG-2700A, 64 WG-2700A
64 WG-2700B

54WG-2500A is similar.

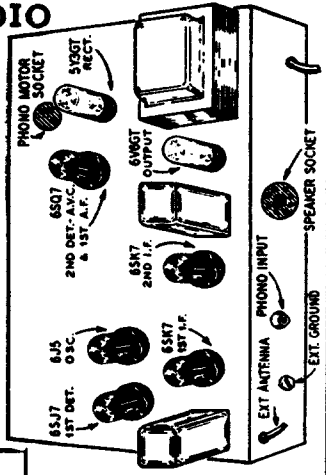
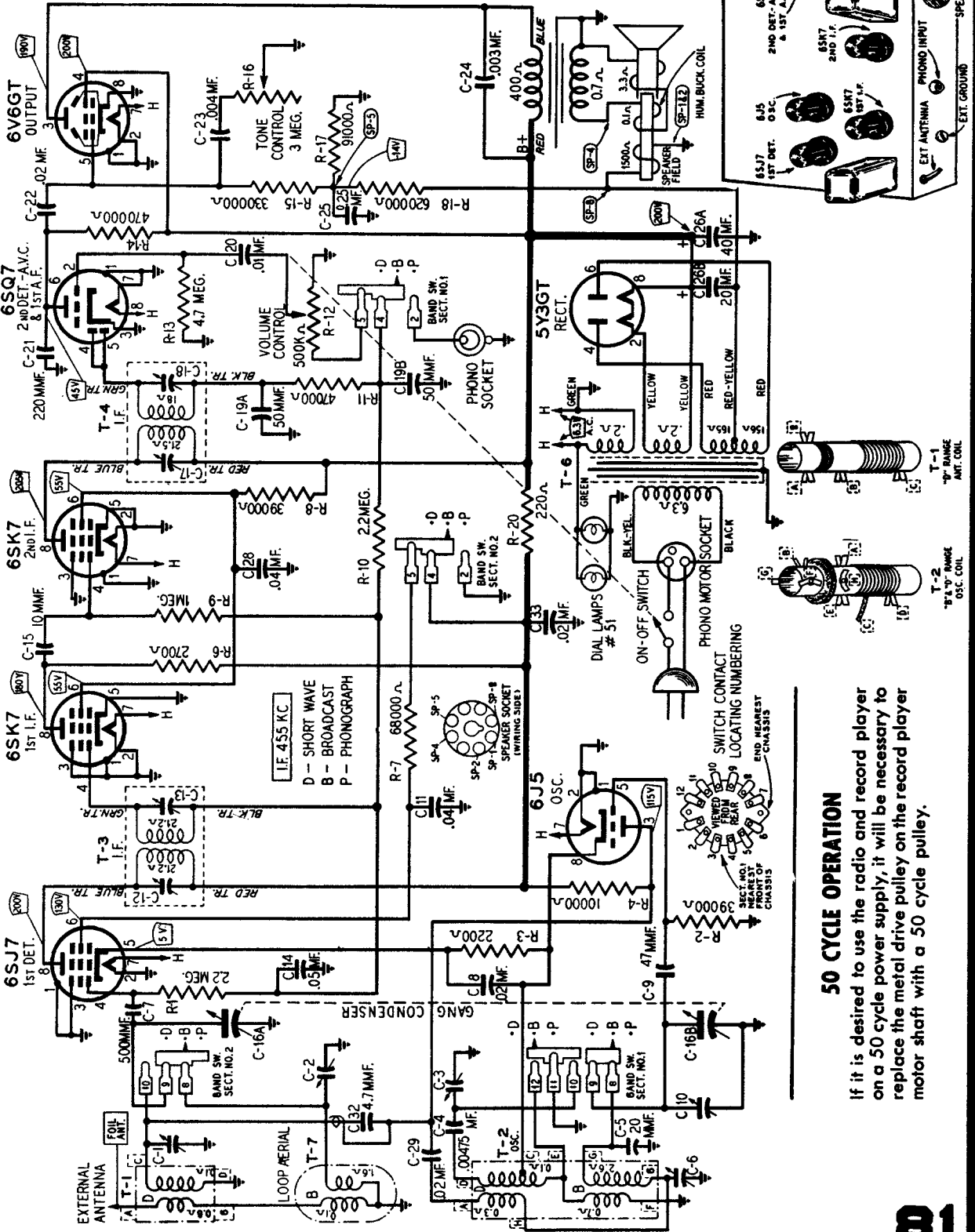

50 CYCLE OPERATION

If it is desired to use the radio and record player on a 50 cycle power supply, it will be necessary to replace the metal drive pulley on the record player motor shaft with a 50 cycle pulley.

MANUAL OF 1947 MOST-OFTEN-NEEDED RADIO DIAGRAMS

ALIGNMENT PROCEDURE

Volume Control—Maximum All Adjustments.
 Connect Radio Chassis to Ground Post of Signal Generator with a Short Heavy Lead.
 Allow Chassis and Signal Generator to "Heat Up" for several Minutes.

The following equipment is required for aligning:
 An All Wave Signal Generator which will provide an accurately calibrated signal at the test frequencies as listed.
 Output Indicating Meter; Non-Metallic Screwdriver.
 Dummy Antennas—.1 mf., 100 mmf., and 400 ohms.

	SIGNAL GENERATOR		Dummy Antenna	Band Switch Setting	Condenser Setting	ADJUST TRIMMERS TO MAXIMUM
	Frequency Setting	Connection at Radio				
I-F	455 kc	6SJ7, Pin 4	.1 mf	B Range	Turn Rotor to Full Open	2nd I-F (C17) & (C18) 1st I-F (C12) & (C13)
RANGE B	1600 kc	Antenna Lead	100 mmf	B Range	Turn Rotor to Full Open	Oscillator Range B (C10)
	1400 kc	Antenna Lead	100 mmf	B Range	Turn Rotor to Max. Output Set Indicator to 1400 KC See Note A	Antenna Range B (C2)
	600 kc	Antenna Lead	100 mmf	B Range	Turn Rotor to Max. Output	600 kc (C6) Rock Rotor—See Note B

Repeat above oscillator adjustments at 1600 and 600 kc until readjusting the oscillator Range B Trimmer (C10) causes no further improvement in output.

RANGE D	18,300 kc	Antenna Lead	400 Ohm	D Range	Turn Rotor to Full Open	Oscillator Range D (C3)
	17,000 kc	Antenna Lead	400 Ohm	D Range	Turn Rotor to Max. Output	Antenna Range D (C1) Rock Rotor—See Note B
LOOP RANGE B	Reassemble chassis in cabinet. 1400 kc	Antenna Lead	100 mmf	B Range	Turn Rotor to Max. Output	Antenna Range B (C2)

After each range is completed, repeat the procedure as a final check.

NOTE A—If the pointer is not at 1400 KC on the dial, re-set

pointer at the 1400 KC mark on the dial scale.
 NOTE B—Turn the rotor back and forth and adjust the trimmer until the peak of greatest intensity is obtained.

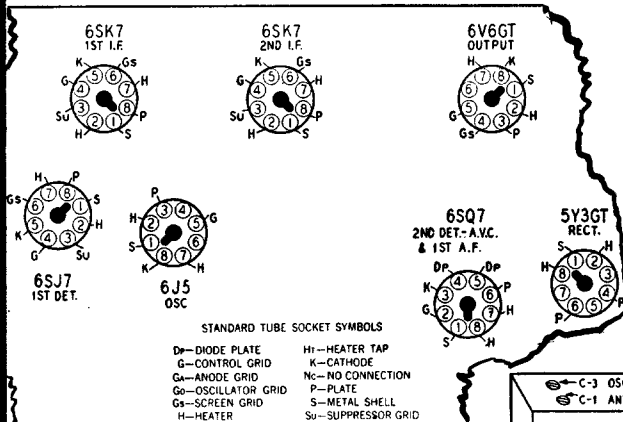

Turn the gang condenser to the fully open position. Use a new drive cord 46" long and tie one end to the tension spring. Hook the other end of the tension spring to the tab on the drive pulley. Pass the cord through the slot in the drive pulley rim and continue one half turn counterclockwise around the drive pulley. Then pass the cord around idler stud A and wind three turns clockwise around the tuning shaft (turns must progress away from chassis). Pass cord through string guide B, over pulleys C and D and around idler stud E. Wrap 3/4 turn counterclockwise around drive pulley, stretch the tension spring and tie free end of the cord to spring. Cut off any excess string.

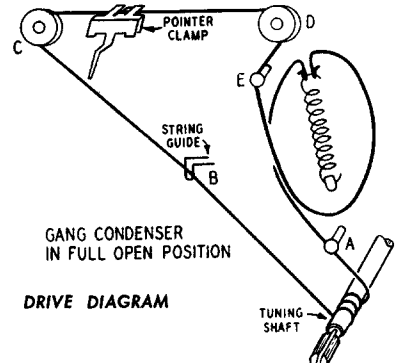
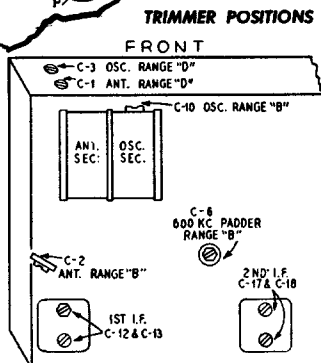

Montgomery Ward & Co.
 Models 54 WG-2700A,
 64 WG-2700A, & -B

WARDS

MODEL 64BR-916A

Power supply . . . 105 to 125 volts AC, 60 cycles, 60 watts
 Power output of amplifier 1.5 watts maximum
 Sensitivity (for 1 watt output) 0.25 volts average

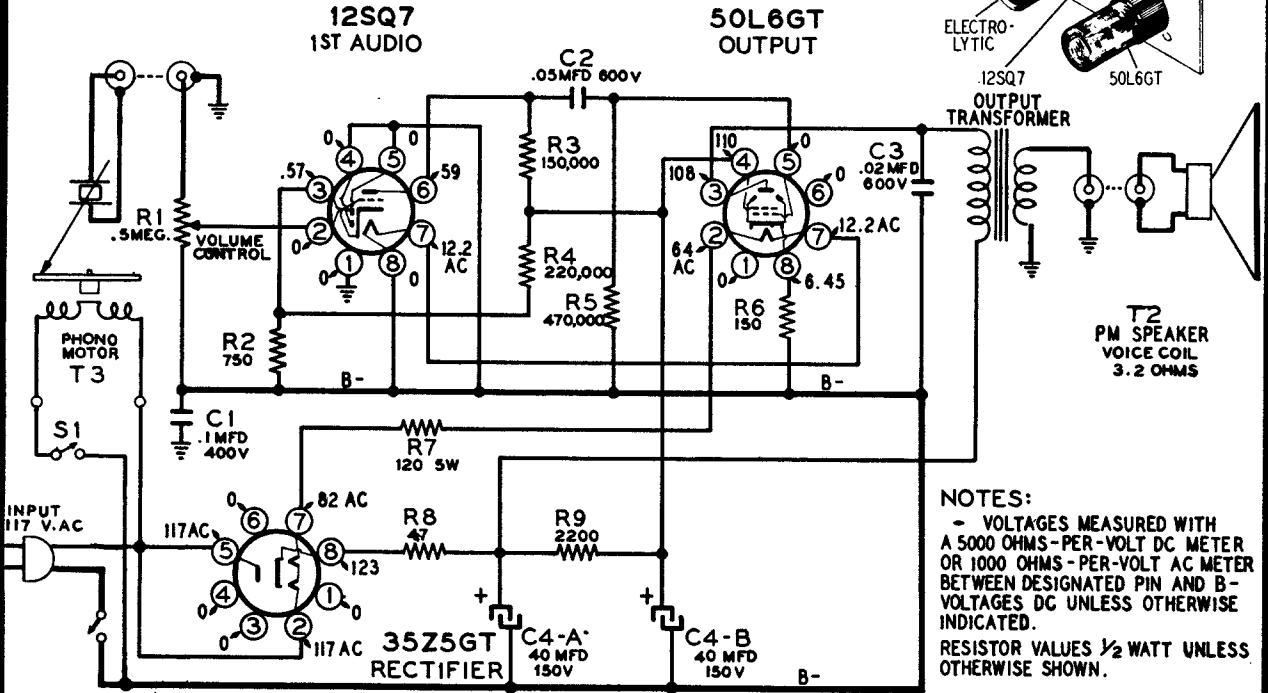
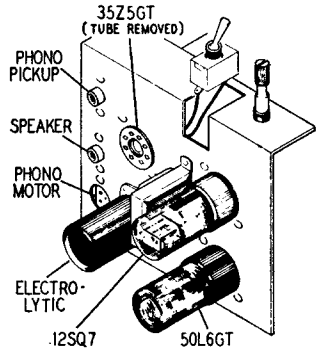

MODEL 64BR-917B

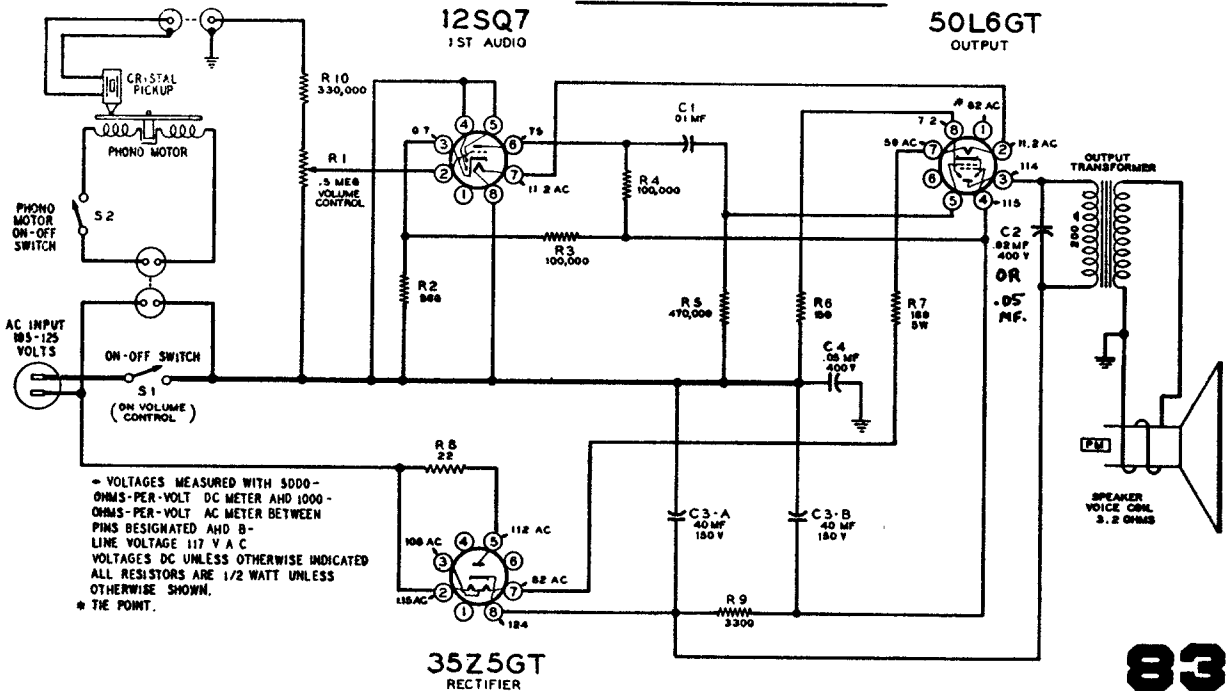

MOST-OFTEN-NEEDED RADIO DIAGRAMS

1S5
2ND DET., A.V.C.
& 1ST AUDIO

MODELS 64BR-1205A, 1206A

1T4
I.F. AMP

1R5
CONVERTER

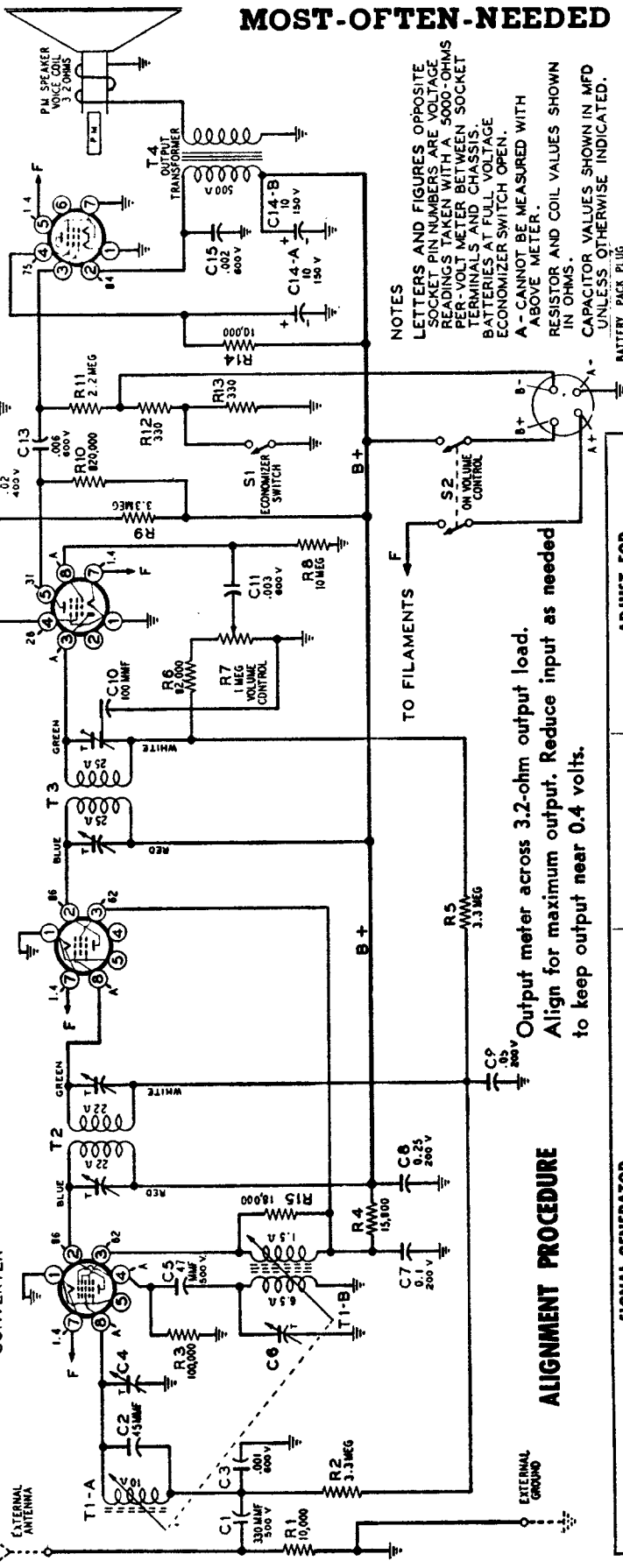

NOTES
LETTERS AND FIGURES OPPOSITE SOCKET PIN NUMBERS ARE VOLTAGE READINGS TAKEN WITH A 5000-OHMS PER-VOLT METER BETWEEN SOCKET TERMINALS AT FULL VOLTAGE. BATTERIES AND CHASSIS. ECONOMIZER SWITCH OPEN.
A - CANNOT BE MEASURED WITH ABOVE METER.
RESISTOR AND COIL VALUES SHOWN IN OHMS.
CAPACITOR VALUES SHOWN IN MFD UNLESS OTHERWISE INDICATED.
BATTERY PACK PLUG AS SEEN FROM WIRING SIDE

Output meter across 3.2-ohm output load. Align for maximum output. Reduce input as needed to keep output near 0.4 volts.

ALIGNMENT PROCEDURE

Frequency	SIGNAL GENERATOR		TUNER SETTING	ADJUST FOR MAXIMUM OUTPUT (in order shown)
	Coupling Capacitor	Connection to Radio		
455 kc	.1 mf	Grid (pin 6) of 1R5	Iron cores all the way out	Trimmers on output and input I. F. cans
1700 kc	.1 mf	Grid (pin 6) of 1R5	Iron cores all the way out	Oscillator trimmer C6
1700 kc	200 mmf	Antenna lead	Iron cores all the way out	Antenna trimmer C4
1400 kc	200 mmf	Antenna lead	Turn dial to 1400 kc	Adjust position of ant. coil (see coil view)*

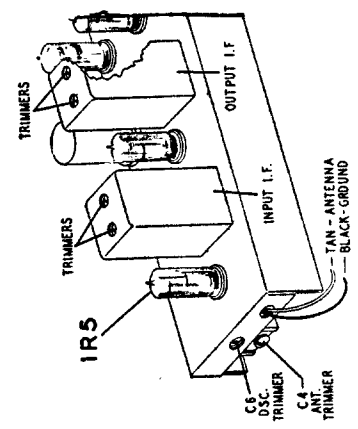

*This adjustment and the previous adjustment are interlocking; therefore repeat the two adjustments alternately for best results.

MANUAL OF 1947 MOST-OFTEN-NEEDED RADIO DIAGRAMS

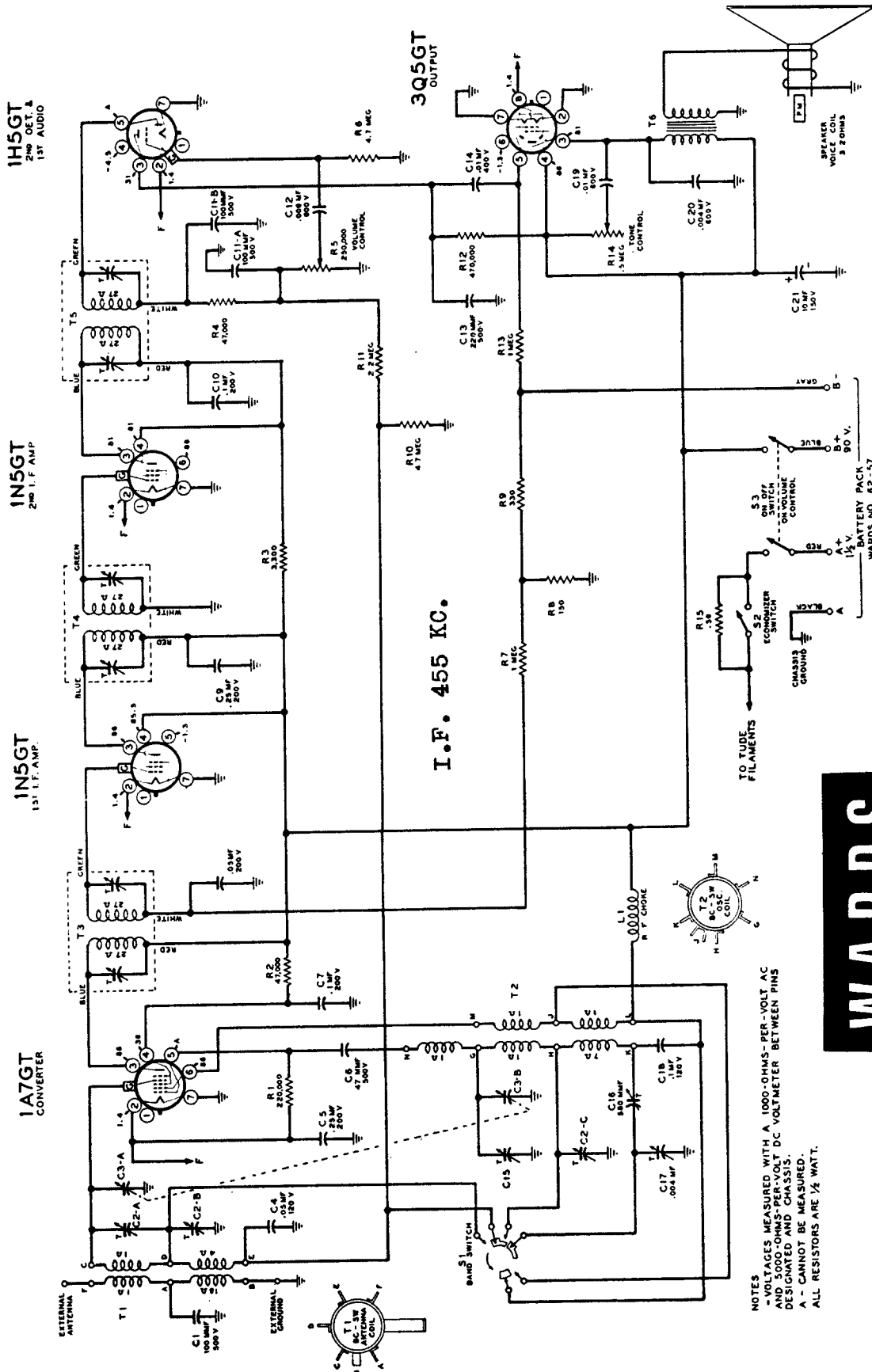

WARDS

MODELS 64BR-1208A, 64BR-2200A

WARDS

MODELS 64BR-1513A, 1514A

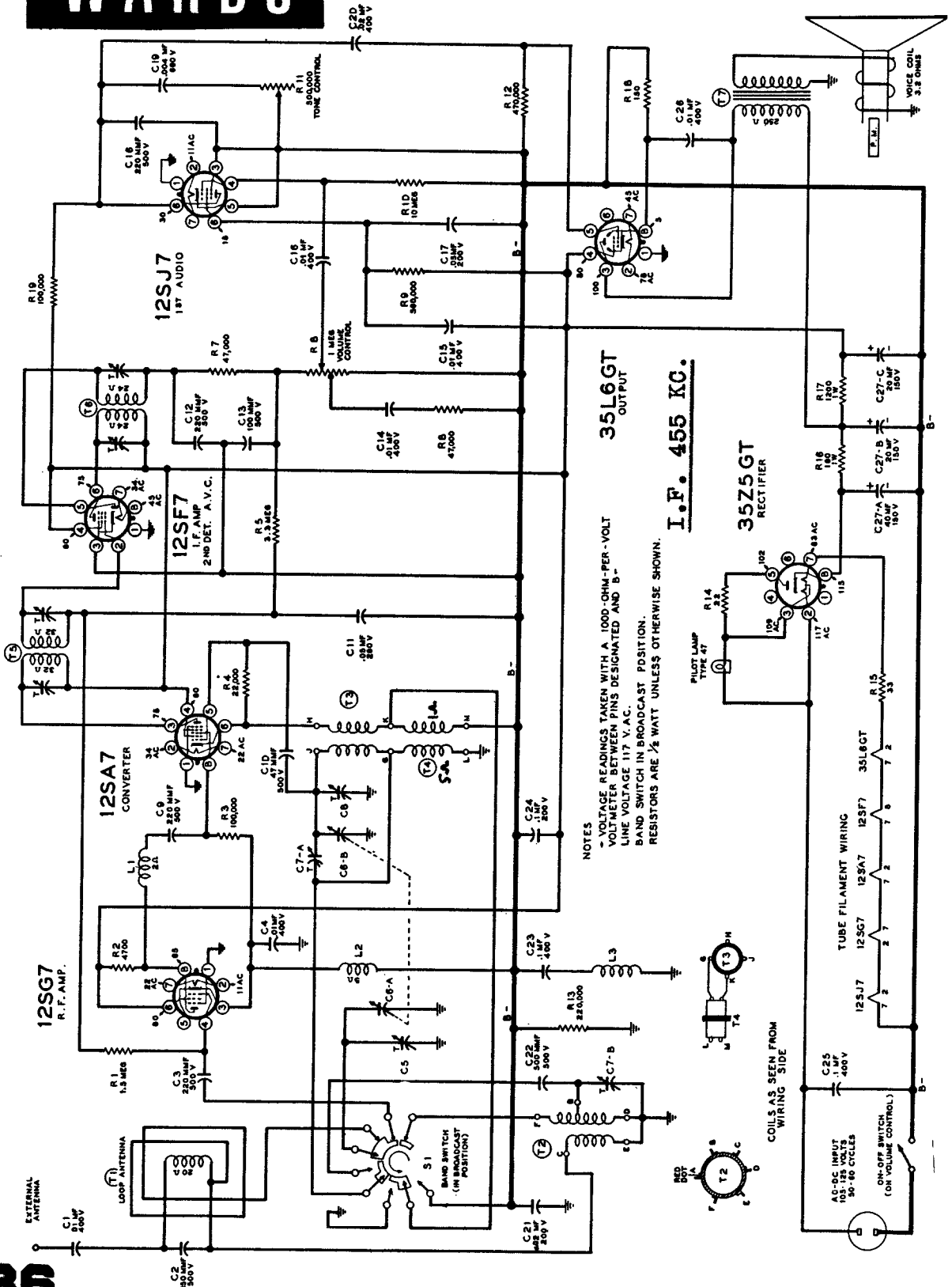

1947 MOST-OFTEN-NEEDED RADIO DIAGRAMS

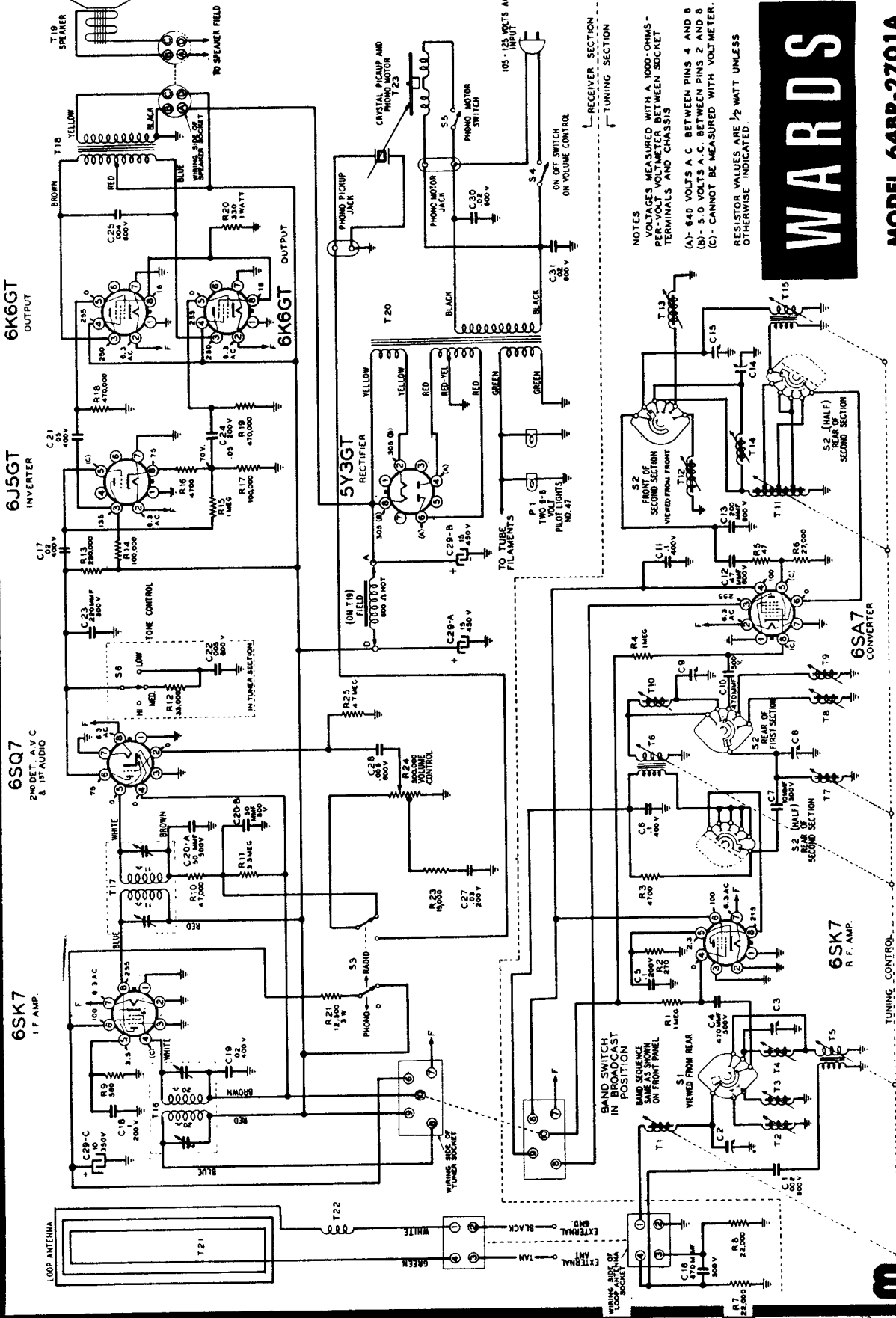

NOTES
 VOLTAGES MEASURED WITH A 1000-OHMS - PER-VOLT VOLTMETER BETWEEN SOCKET TERMINALS AND CHASSIS
 (A) - 640 VOLTS A.C. BETWEEN PINS 4 AND 6
 (B) - 5.0 VOLTS A.C. BETWEEN PINS 2 AND 8
 (C) - CANNOT BE MEASURED WITH VOLTMETER.
 RESISTOR VALUES ARE 1/2 WATT UNLESS OTHERWISE INDICATED.

WARDS

MODEL 64BR-2701A

MANUAL OF 1947 MOST-OFTEN-NEEDED RADIO DIAGRAMS

M O N T G O M E R Y W A R D

MODEL 64BR-2701A

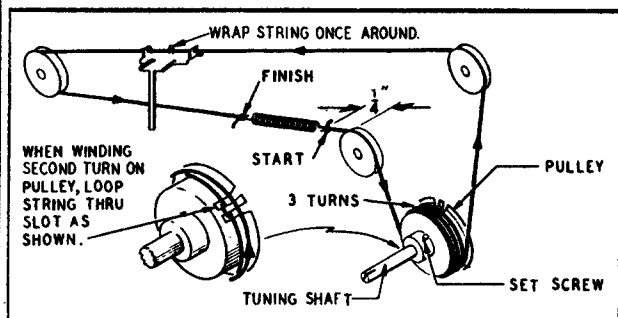

Replacing Dial Pointer Drive Cord

After stringing, spring must be $1/4$ " from idler when tuning shaft is in extreme counterclockwise position. To do this: Loosen set screw; hold tuning shaft firm and turn pulley by hand until spring is $1/4$ " from idler; tighten screw.

MECHANICAL ADJUSTMENT—The core tuning bar (see illustration of coils below) and dial pointer must be adjusted mechanically before any electrical alignment is attempted. Rotate the manual tuning control until the core bar is farthest from the coils. For proper adjustment the bar should be approximately $1/32$ of an inch from the two rod guide angles.

With the core bar in this position, adjust the dial pointer to coincide with 1600 kc on the dial scale (see pointer alignment diagram).

Rotate the core of each of the three broadcast coils (see illustration) until the end of the core is $1-5/32$ " from the end of the coil form. Rotate the three 9-mc cores until this dimension is $1-1/6$ " for these coils.

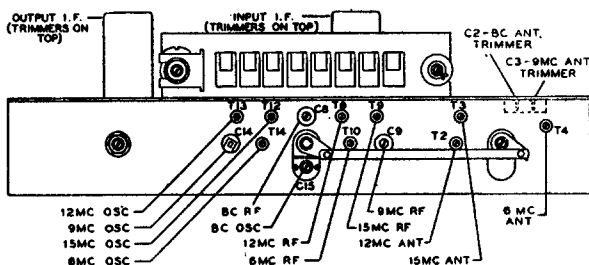
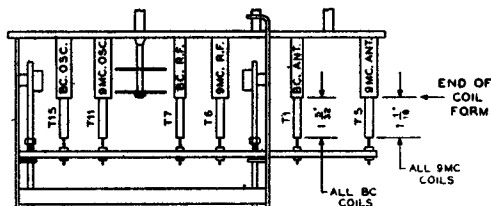

ELECTRICAL ADJUSTMENT—To align the set make the following preliminary adjustments: Set the tone pushbutton for treble tone; set the volume control at maximum; connect the ground post of the signal generator to the radio chassis; connect the output meter across a 3.2-ohm output load; and allow the receiver and signal generator to warm up for several minutes.

Align the set according to the sequence given in the chart. The indicated coupling capacitor is to be connected in series between the signal generator output lead and the receiver. Adjust the set for maximum output; reduce the input as needed to keep the output near 1.3 volts.

BAND SWITCH SETTING	SIGNAL GENERATOR			DIAL POINTER SETTING	ADJUST TO MAXIMUM OUTPUT IN ORDER SHOWN
	Frequency	Coupling Capacitor	Connection to Receiver		
Broadcast (for I. F.)	455 kc	.1 mf	Grid (pin 8) of converter (6SA7)	1600 kc	Trimmers on output and input I. F. cans
Broadcast	1600 kc	200 mmf	Antenna lead	1600 kc	BC Osc. trimmer C15 BC R. F. trimmer C8 BC Ant. trimmer C2
	1400 kc	200 mmf	Antenna lead	1400 kc	Rotate cores of BC R. F. coil T7 and BC Ant. coil T1
31 Meter	9.6 mc	400 ohms	Antenna lead	9.6 mc	9 mc Osc. trimmer C14 9 mc R. F. trimmer C9 9 mc Ant. trimmer C3
49 Meter	6.1 mc	400 ohms	Antenna lead	6.1 mc	6 mc Osc. coil T14 6 mc R. F. coil T10 6 mc Ant. coil T4
25 Meter	11.8 mc	400 ohms	Antenna lead	11.8 mc	12 mc Osc. coil T13 12 mc R. F. coil T8 12 mc Ant. coil T2
19 Meter	15.2 mc	400 ohms	Antenna lead	15.2 mc	15 mc Osc. coil T12 15 mc R. F. coil T9 15 mc Ant. coil T3

WARDS - Airline AMPLIFIER

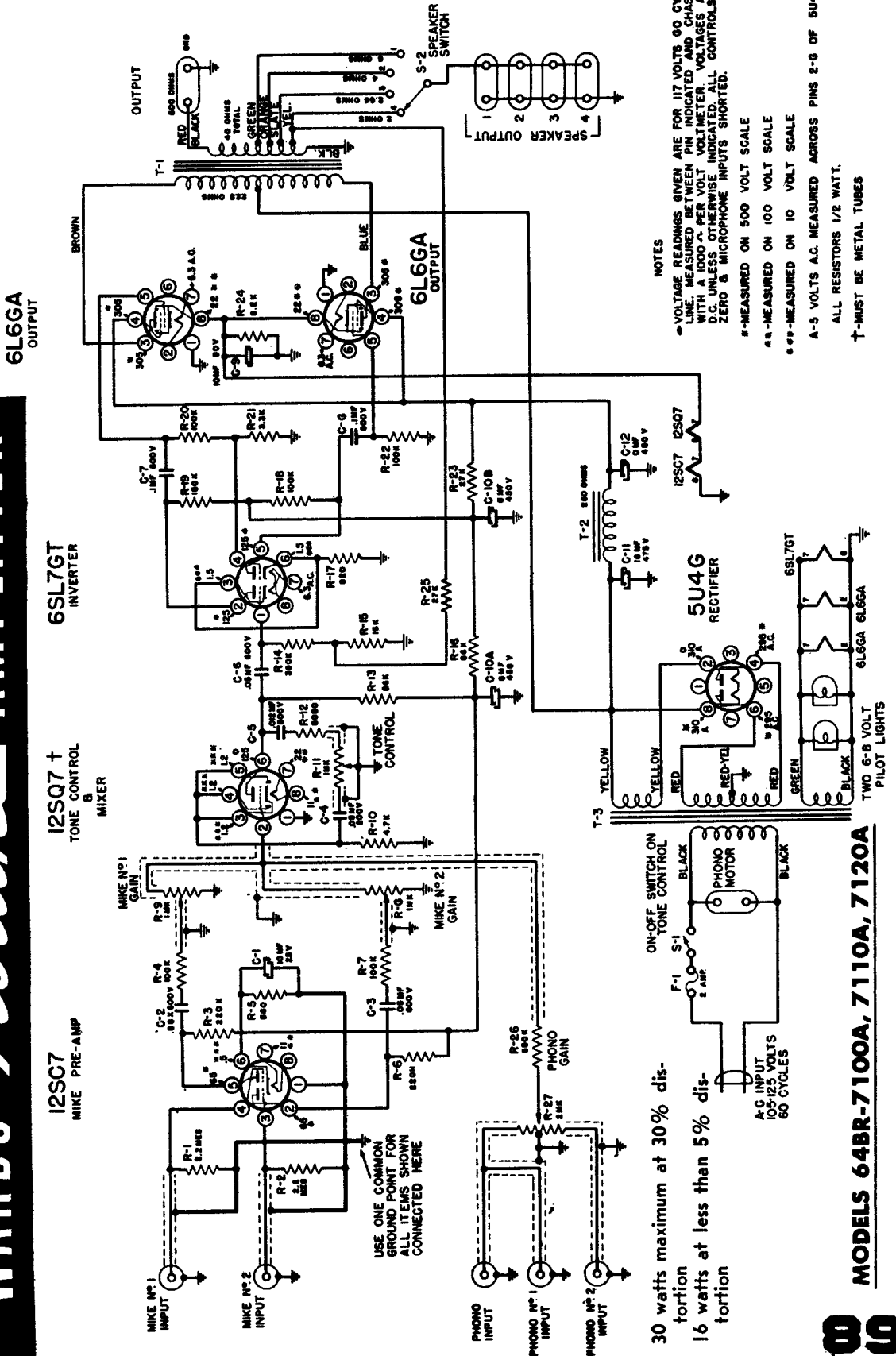

MODELS 64BR-7100A, 7110A, 7120A



MANUAL OF 1947 MOST-OFTEN-NEEDED RADIO DIAGRAMS

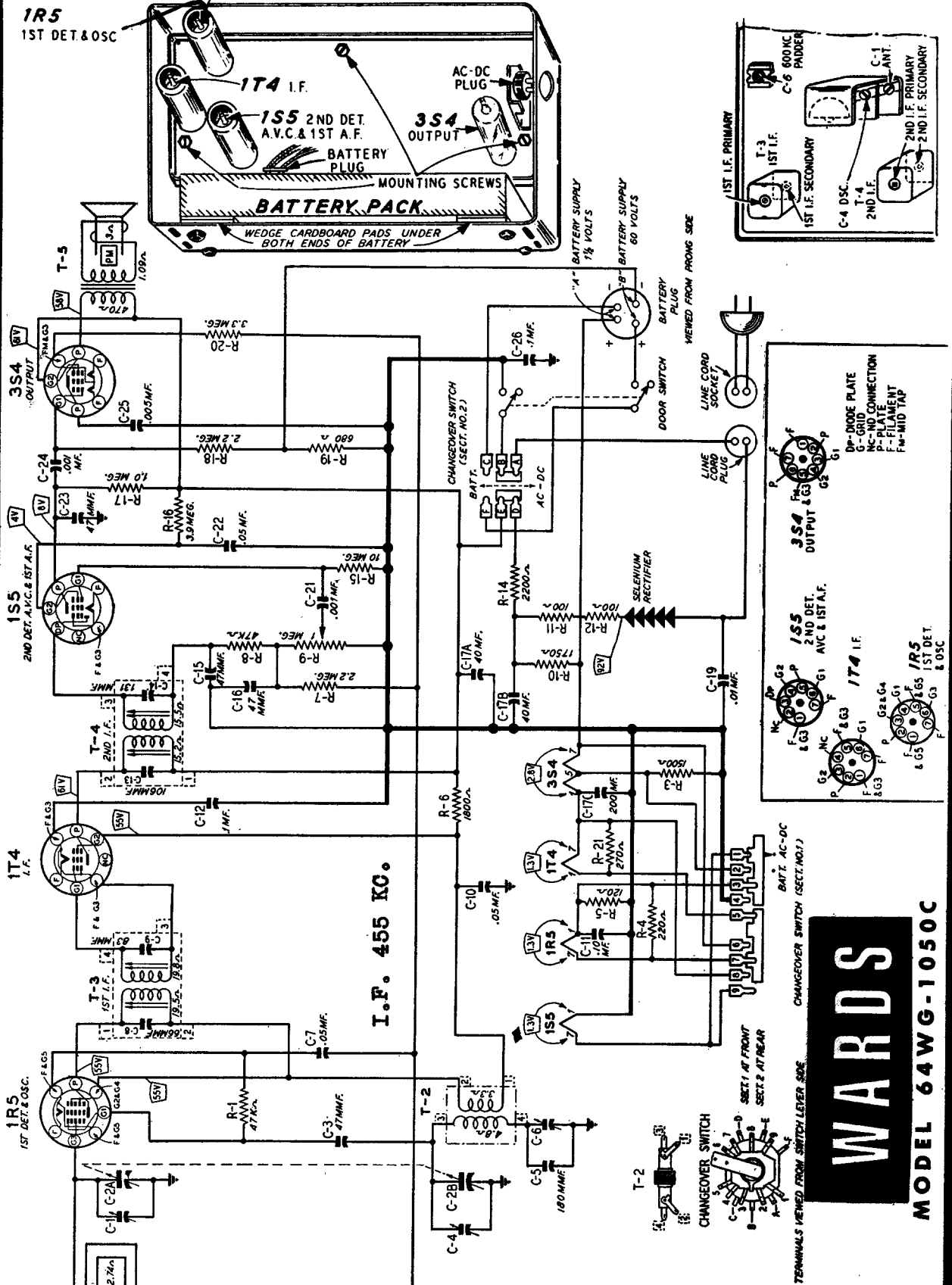

MANUAL OF 1947 MOST-OFTEN-NEEDED RADIO DIAGRAMS

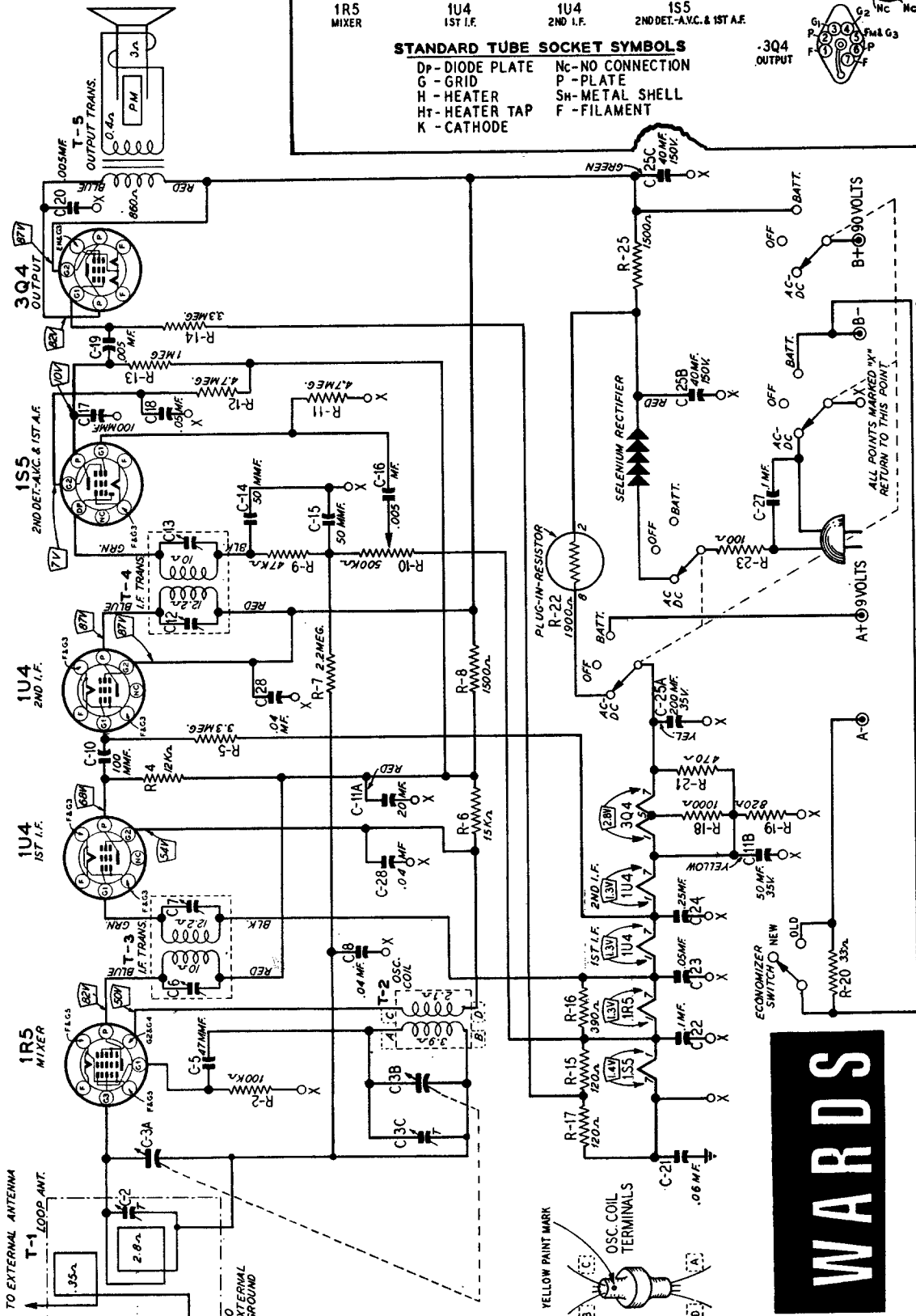
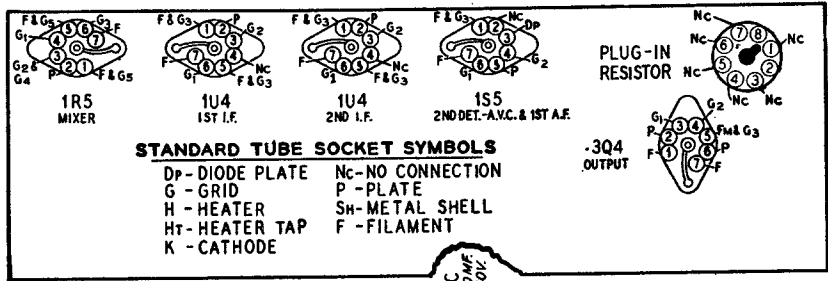

WARDS

MODEL 64 WG-1052A

MANUAL OF 1947 MOST-OFTEN-NEEDED RADIO DIAGRAMS

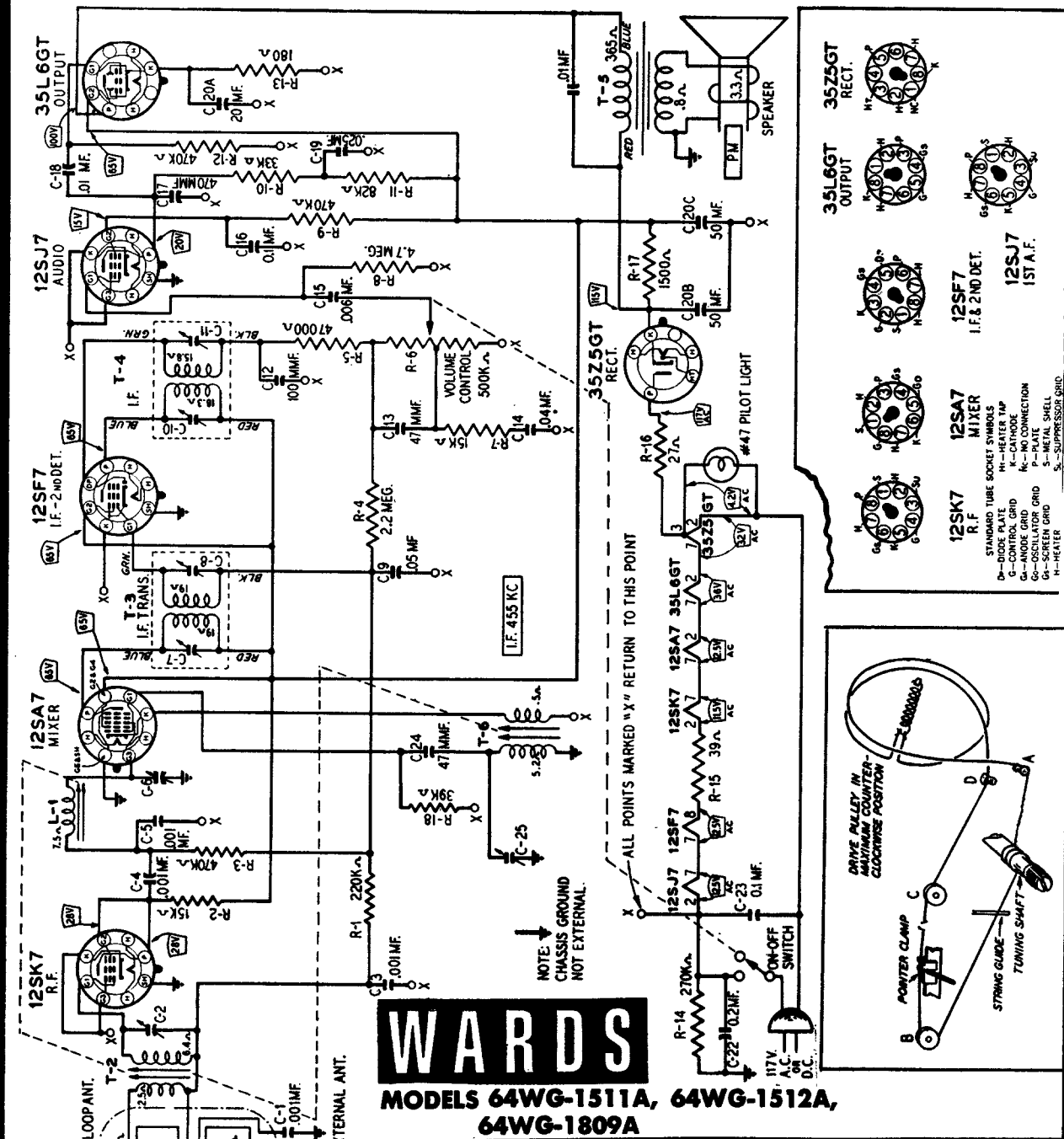

WARDS

MODELS 64WG-1511A, 64WG-1512A, 64WG-1809A

SIGNAL GENERATOR

Frequency Setting	Connection to Receiver	Ground Connection	Coupling Capacitor	DIAL SETTING	ADJUST TRIMMERS TO MAXIMUM OUTPUT IN ORDER SHOWN (See Trimmer Illustration)
455 kc	Control Grid 12SF7-I-F (Prong No. 2)	Point "X" 12SK7-R-F (Prong No. 3)	.1 mf	1600 kc	2nd I-F (C10) & (C11)
455 kc	Control Grid 12SA7-1st Det. (Prong No. 8)	Same as above	.1 mf	1600 kc	1st I-F (C7) & (C8)
1400 kc	Control Grid 12SA7-1st Det. (Prong No. 8)	Same as above	.1 mf	1400 kc Index Line. See Note A	Oscillator (C25)
1400 kc	External Antenna Clip on Loop	Chassis	50 mmf	1400 kc Index Line. See Note A	R-F (C-6) Antenna (C-2)

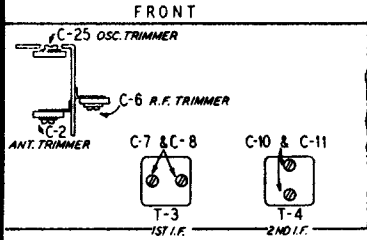

WARDS

MODEL 64 WG-1207B

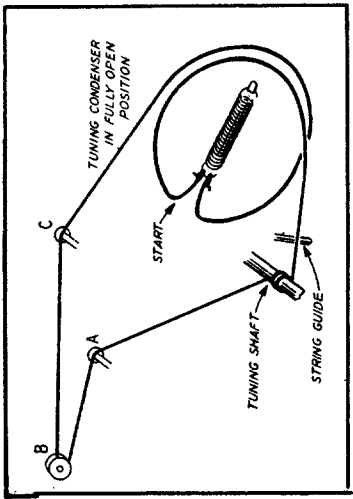
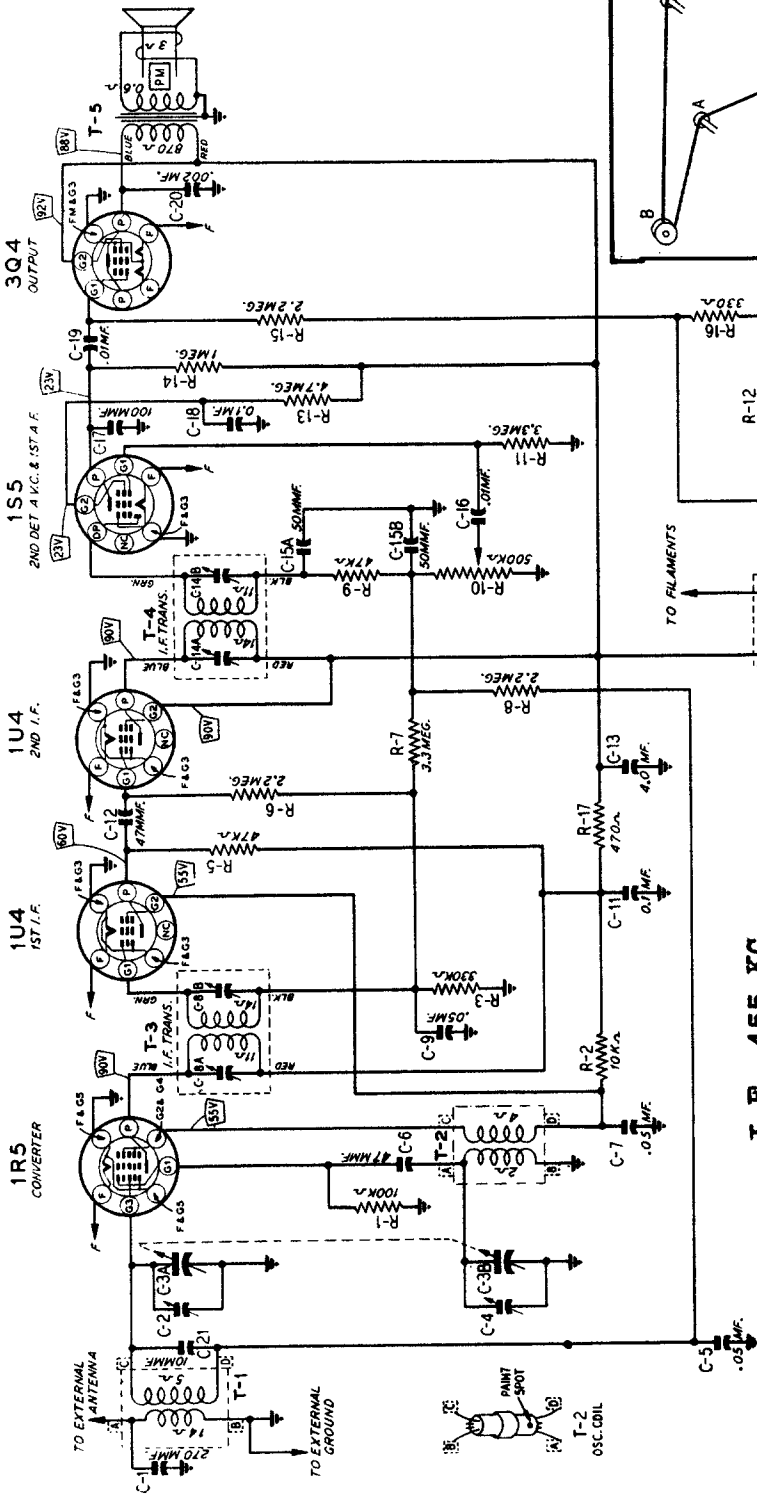

Socket voltages are shown on the schematic diagram at the tube socket terminals. All voltages are between the socket terminal and the chassis. All readings, except those for the 1S5 tube, were taken with a 1000 ohm-per-volt meter and read on a 500 volt scale. The plate and screen voltages for the 1S5 tube were read with a vacuum tube voltmeter. Conditions of measurement are:

Battery voltages under load..... B, 90 volts
 A, 1 1/2 Volts

Volume control..... maximum
 Signal input..... none

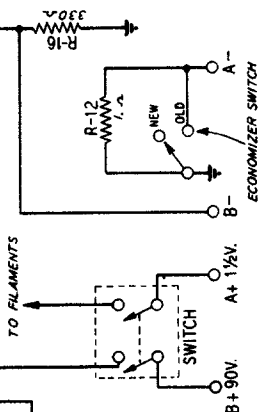

I. F. 455 KC.

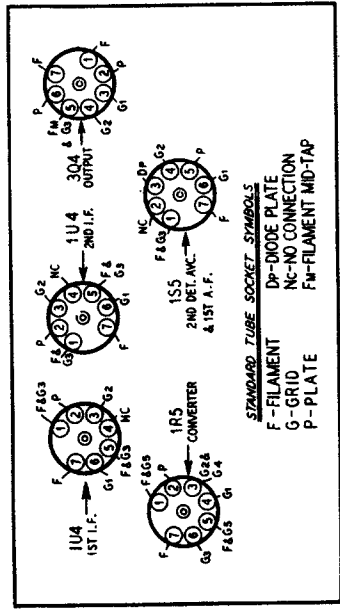

MANUAL OF 1947 MOST-OFTEN-NEEDED RADIO DIAGRAMS

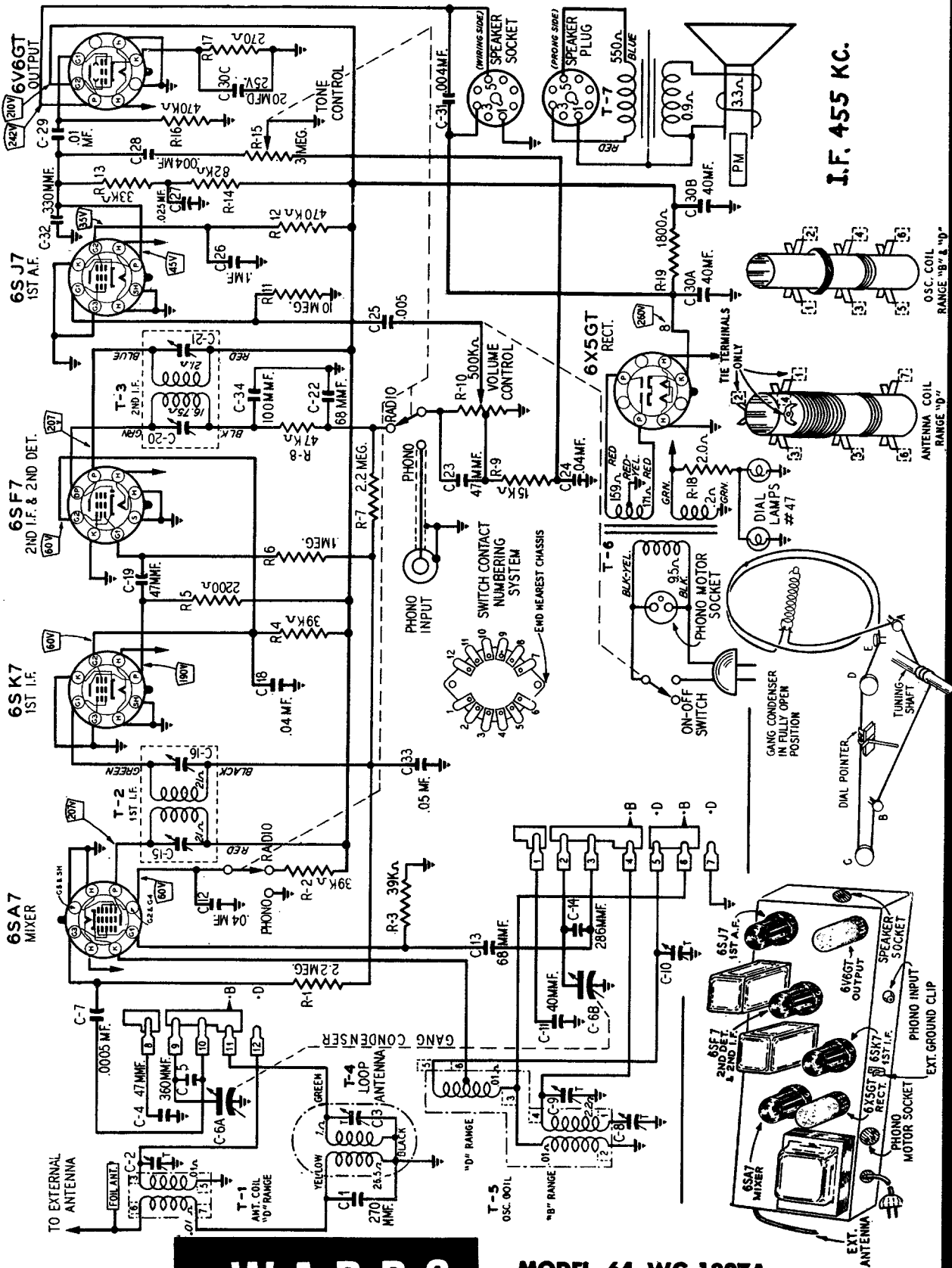

I.F. 455 KC.

MANUAL OF 1947 MOST-OFTEN-NEEDED RADIO DIAGRAMS

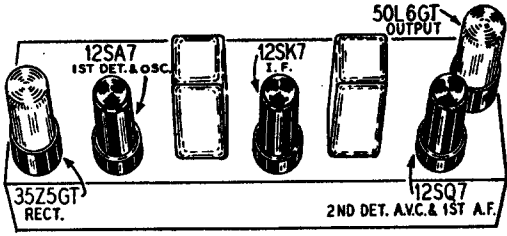

DRIVE
CORD
DIAGRAM

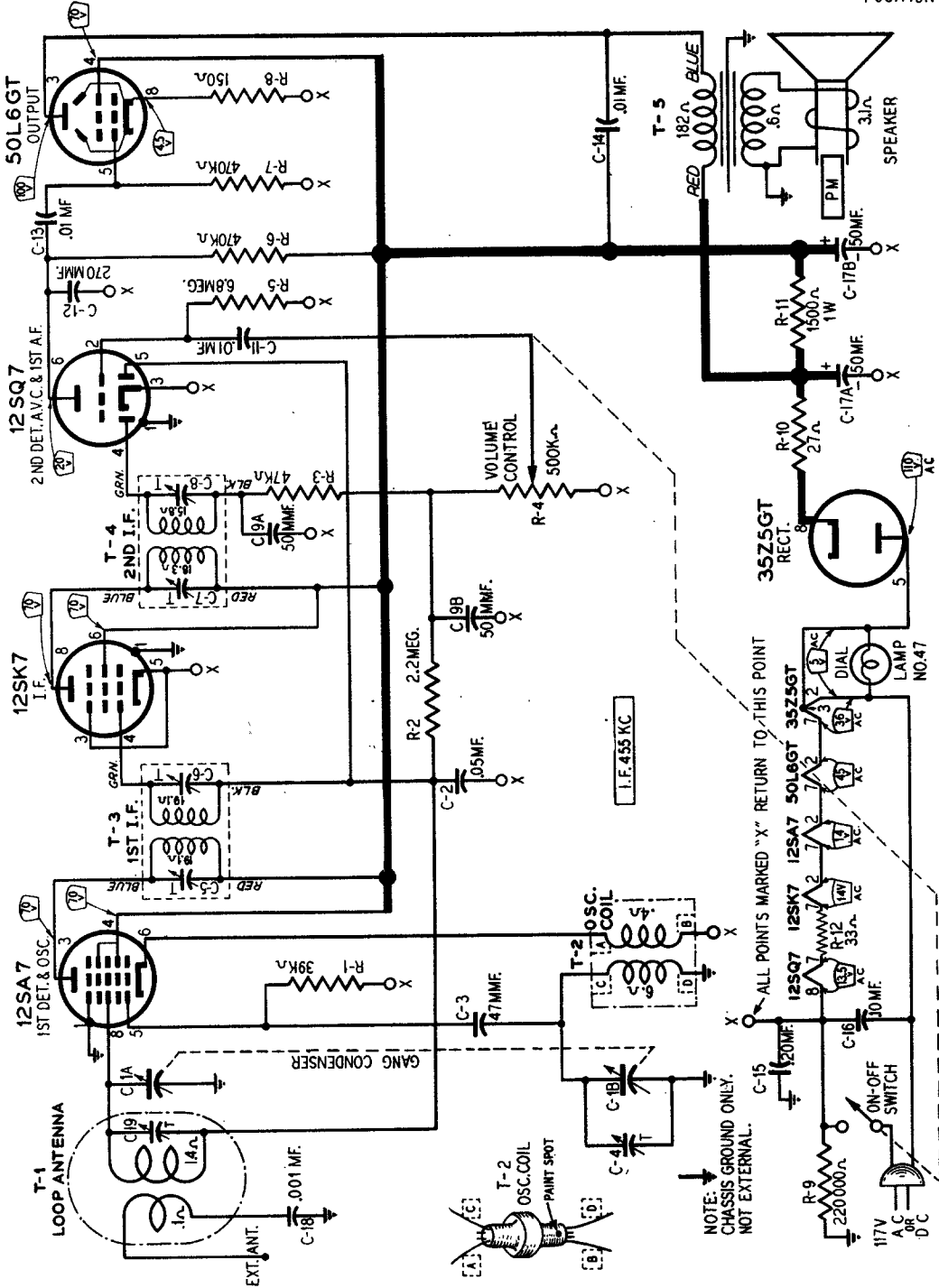

MODELS 64 WG-1801C

WARDS

MANUAL OF 1947 MOST-OFTEN-NEEDED RADIO DIAGRAMS

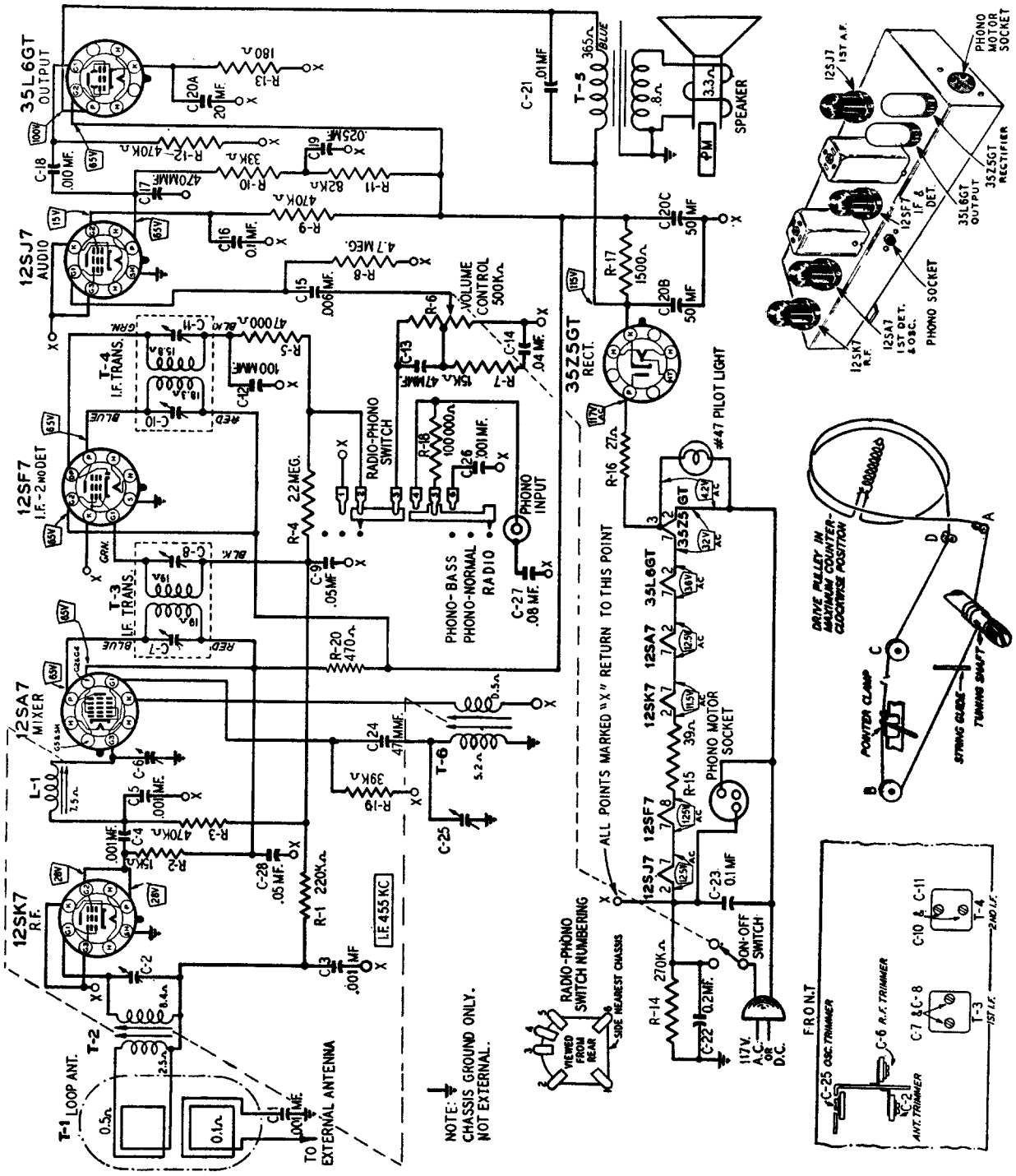

MODEL 64 WG-2009B

WARDS

Frequency Range.....540-1600 KC
 Intermediate Frequency 455 KC

WARDS

MODEL 64 WG-2500B

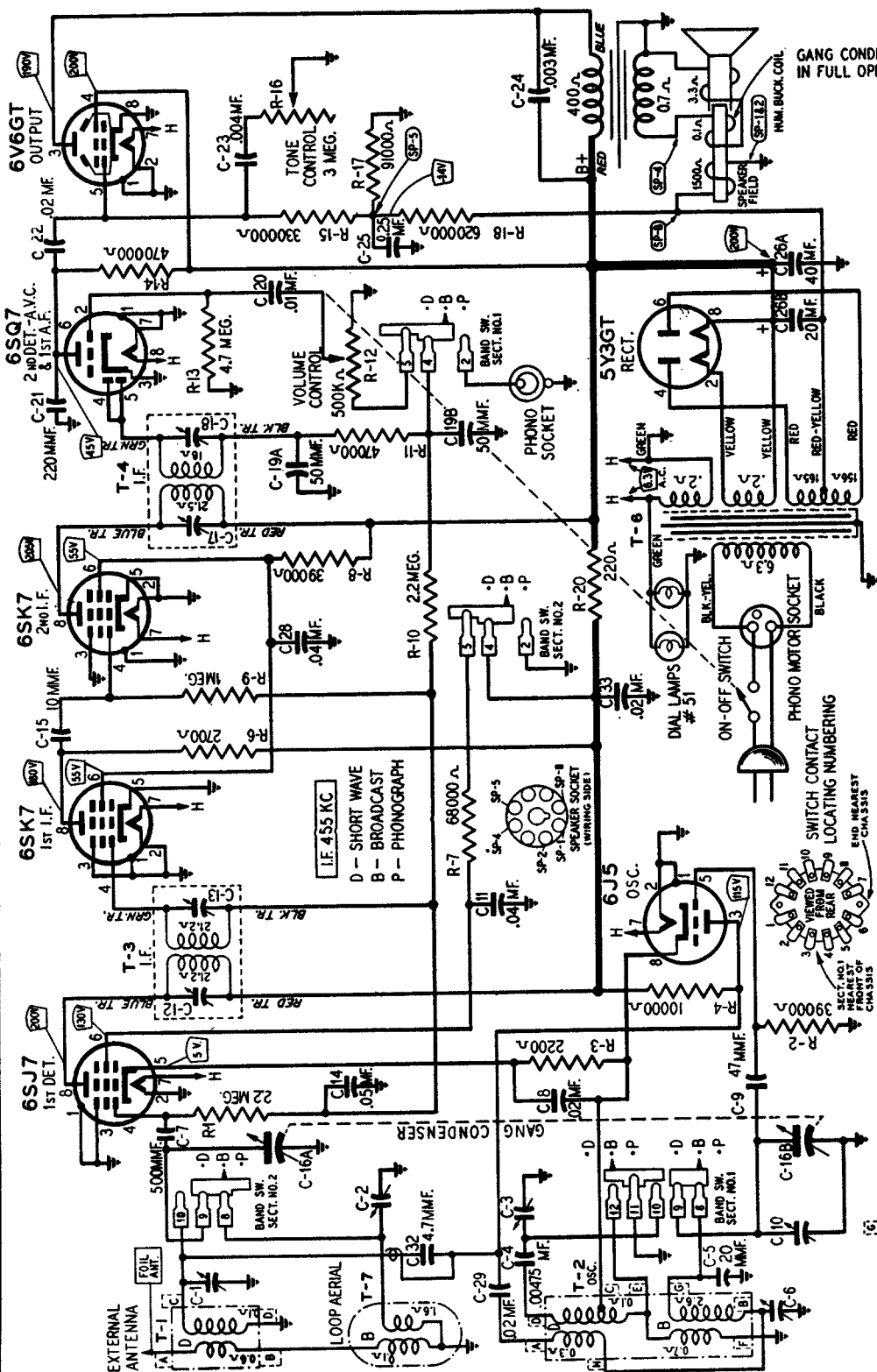
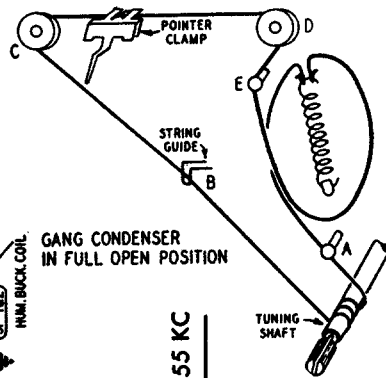

Intermediate Frequency .455 KC

TUBE SOCKET VOLTAGES

Socket voltages are shown on the schematic diagram at the tube socket terminals. All voltages are between the socket terminal and chassis ground. The readings were taken with a 1000 ohm per volt meter and all plate and screen voltages read on a 500 volt scale.

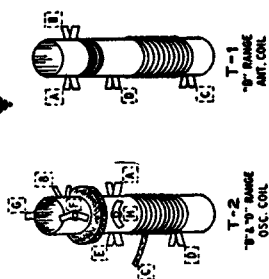

Motorola **AUTO** Radio

MODEL CR6

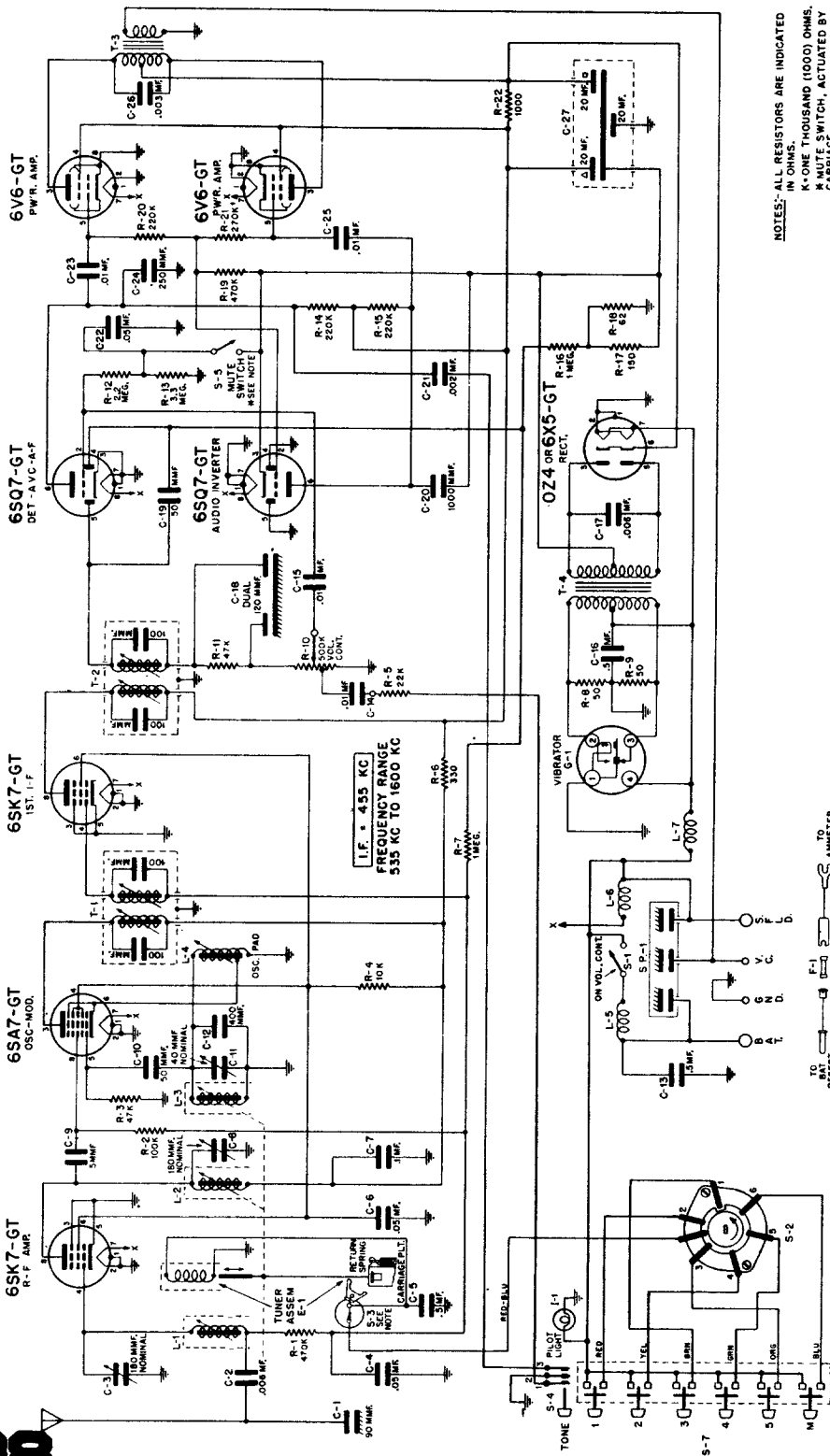

NOTES: ALL RESISTORS ARE INDICATED IN OHMS.
 K-ONE THOUSAND (1000) OHMS.
 M-ONE MILLI (1000) OHMS.
 SWITCH, ACTUATED BY CARRIAGE
 SWITCH S-3 (ON TUNER) IS ACTUATED BY CARRIAGE PLATE WHEN ELECTRICALLY TUNED.
 S-4 TONE SWITCH
 S-5 POSITION #1 OPEN
 S-5 POSITION #2 CONTACTS CLOSED.
 S-5 POSITION #1-2-3 CONTACTS CLOSED.
 R-18 CHANGED TO 56 OHMS IN LATE MODELS.
 C-22 CHANGED TO .1 MF IN LATE MODELS.



Motorola Model CR6 is an 8 tube automotive type superheterodyne radio receiver specifically designed for installation in 1946 Plymouth, Dodge, DeSoto and Chrysler cars.

Alignment information on Model CR6 is on the next page.

MANUAL OF 1947 MOST-OFTEN-NEEDED RADIO DIAGRAMS

Motorola **AUTO** Radio

MODEL CR6 ALIGNMENT TABLE

STEP	TUNER POSITION SET TO	DUMMY ANTENNA	SIGNAL GENERATOR LEAD CONNECTED TO	-SIG.GEN. SET AT	ADJUST FOR PEAK ON OUTPUT METER
1.	High frequency end (cores out)	.1 mfd. at Sig. Gen.	Osc.-Mod. grid (#5 pin)	455 Kc	#1 and 2 P & S in T-1 #3 and 4 P & S in T-2
2.	High frequency end, tuning shaft against stop. Cores should be set to project 1-1/8" from cans.	60 mmf. at Sig.Gen. in series in 21" long coax lead.	Antenna Receptacle	1600 Kc	#5 Osc. trimmer C-11 #6 R.F. trimmer C-8 #7 Ant. trimmer C-3
3.	EXACTLY one full turn in from high frequency end. Use knob set screw as an indicator. Start measuring turn the moment tuner carriage starts moving inward.	"	"	1425 Kc	#8 Osc. Core of L-3 #9 R.F. Core of L-2 #10 Ant. Core of L-1
4.	EXACTLY four more full turns in (as indicated by knob setscrew)	"	"	Power turned OFF	#11 Osc.Pad core of L-4 for maximum noise.
5.	Assemble and install receiver in car and connect car antenna. Turn the dial to approximately 1400 Kc (not to a local station) and adjust antenna trimmer for maximum noise.				

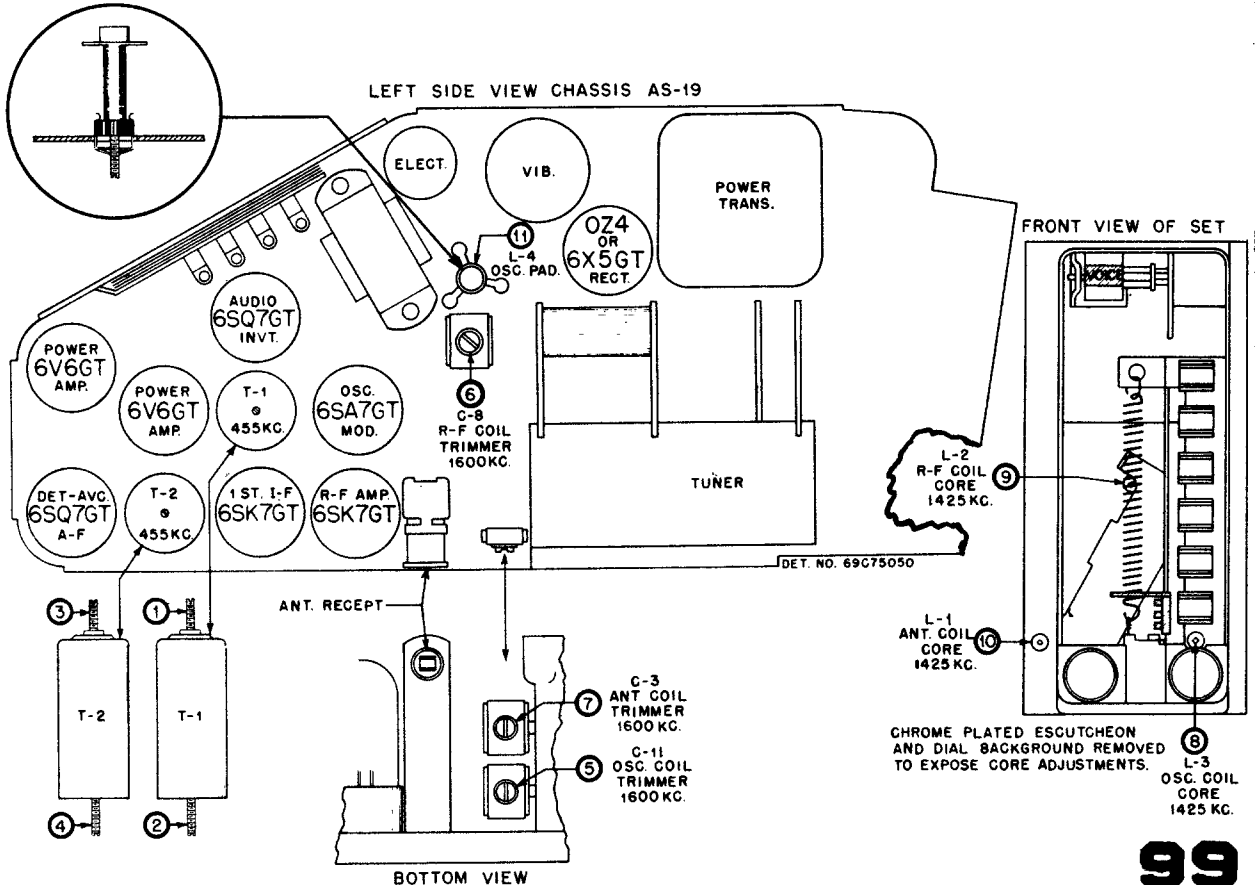

Motorola HOME Radio

6J5GT
RECT.

6SK7GT
OSC-MOD.

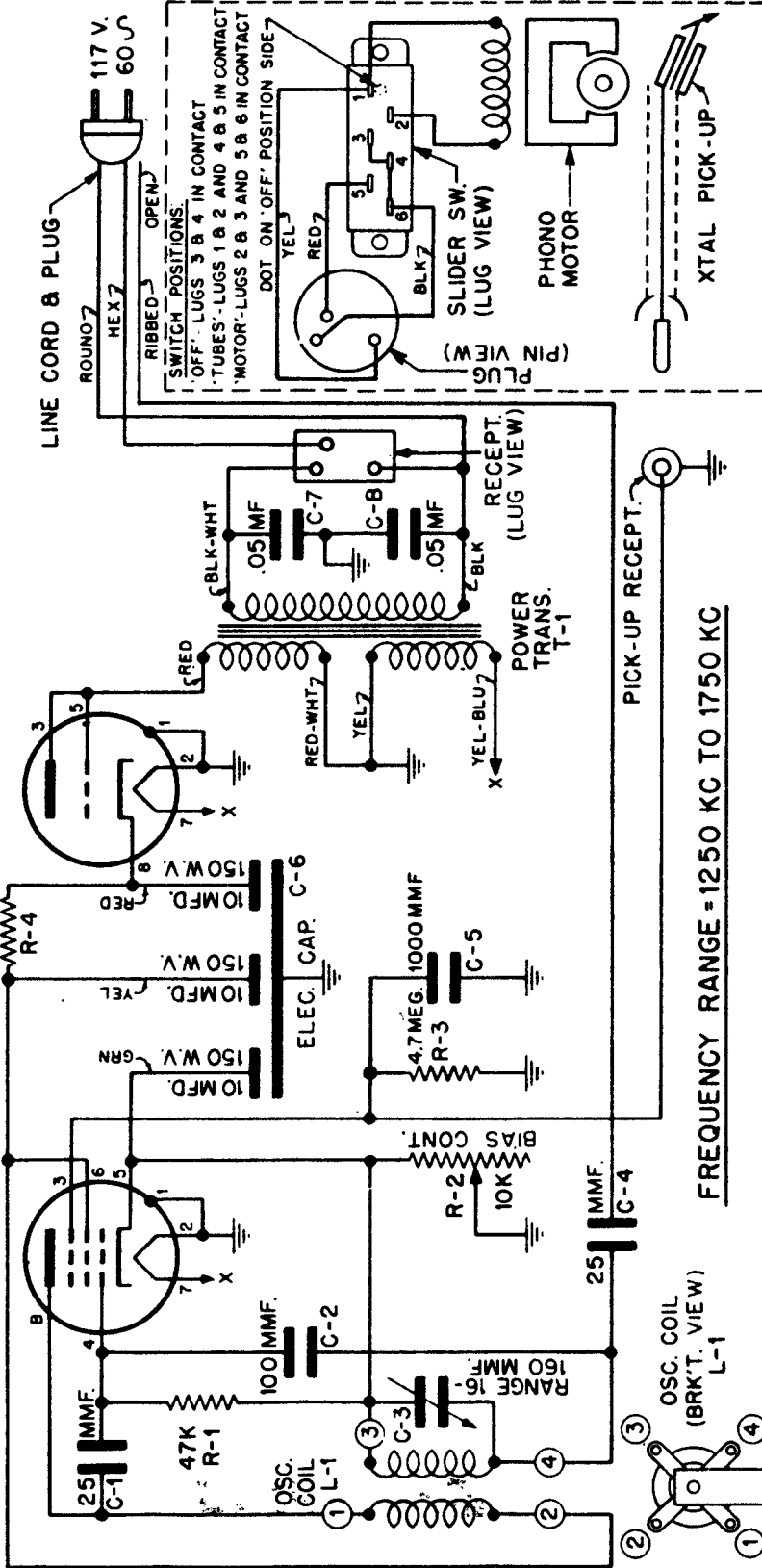

FREQUENCY RANGE = 1250 KC TO 1750 KC

NOTE: ALL RESISTORS ARE MEASURED IN OHMS UNLESS OTHERWISE SPECIFIED.

NOTE: ALL VOLTAGES MEASURED WITH A 1,000 OHM PER VOLT VOLTMETER TO CHASSIS. * VARIES WITH SETTING OF BIAS CONTROL.

CHASSIS HS-18

MODEL WR6, 7 & 8

B-25-RC RECORD CHANGER

BOTTOM VIEW OF CHASSIS

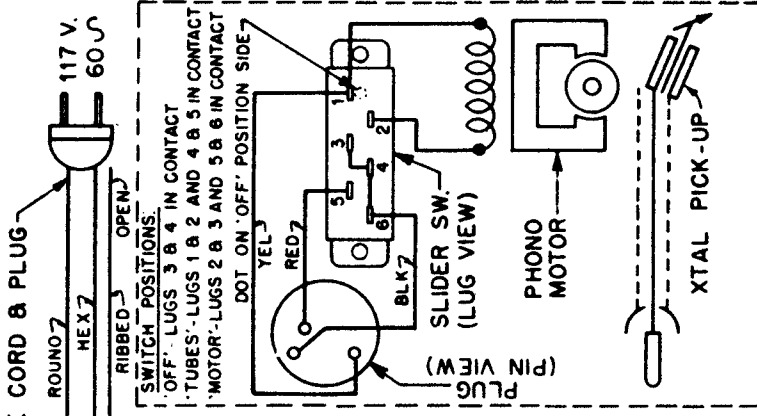
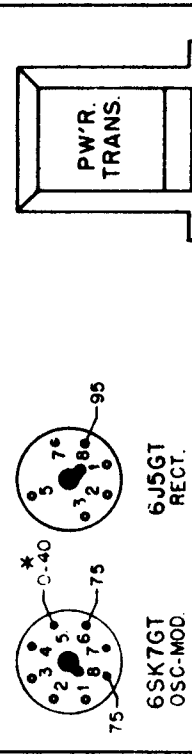

XTAL PICK-UP

GALVIN MANUFACTURING CORPORATION

Motorola HOME Radio

Motorola

Model 55F11
Chassis HS-30

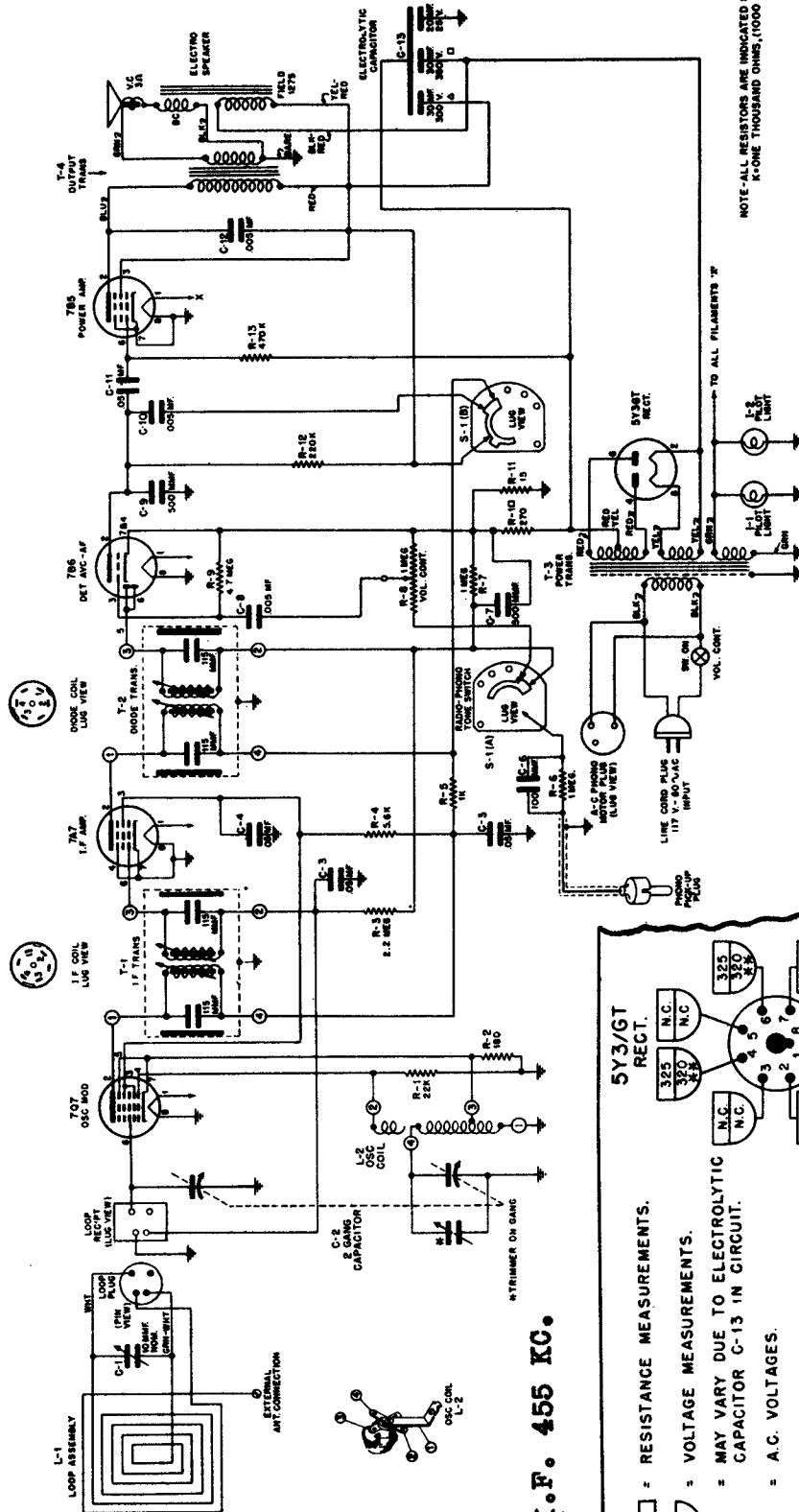

NOTE-ALL RESISTORS ARE INDICATED IN OHMS
K-ONE THOUSAND OHMS,(1,000 OHMS).

NOTE: A VTVM WAS USED TO MAKE VOLTAGE MEASUREMENTS.
ALL MEASUREMENTS ARE MADE FROM TUBE BASE 'PIN'
TERMINALS TO CHASSIS.

I.F. 455 KC.

- = RESISTANCE MEASUREMENTS.
- = VOLTAGE MEASUREMENTS.
- * = MAY VARY DUE TO ELECTROLYTIC CAPACITOR C-13 IN CIRCUIT.
- ** = A.C. VOLTAGES.

PHONO-RADIO SWITCH IN RADIO POSITION
VOLUME CONTROL ON FULL, DIAL SET TO L.
AND NO STATION TUNED IN.
VOLTAGE TOLERANCE ± 10%.
RESISTANCE TOLERANCE ± 20%.

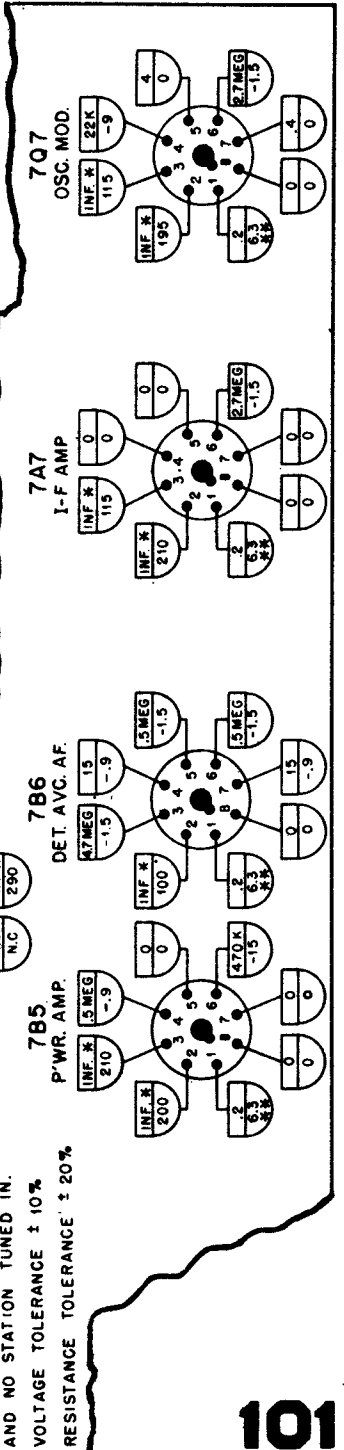

MANUAL OF 1947 MOST-OFTEN-NEEDED RADIO DIAGRAMS

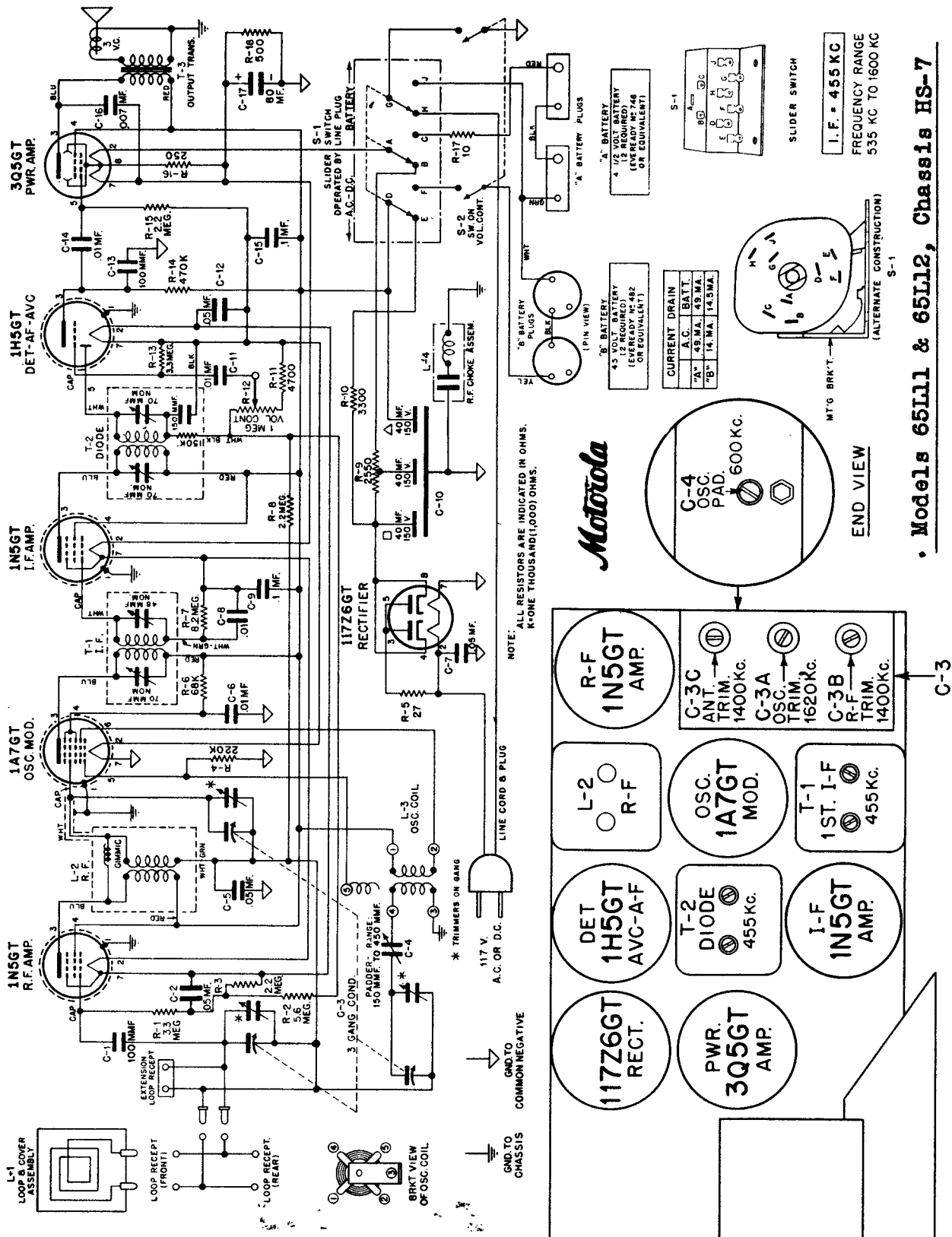

MANUAL OF 1947 MOST-OFTEN-NEEDED RADIO DIAGRAMS

Motorola Models
 55X11, 55X12, 55X13, 55X11-A,
 55X12-A, & 55X13-A.
 Chassis HS-1, HS-50.

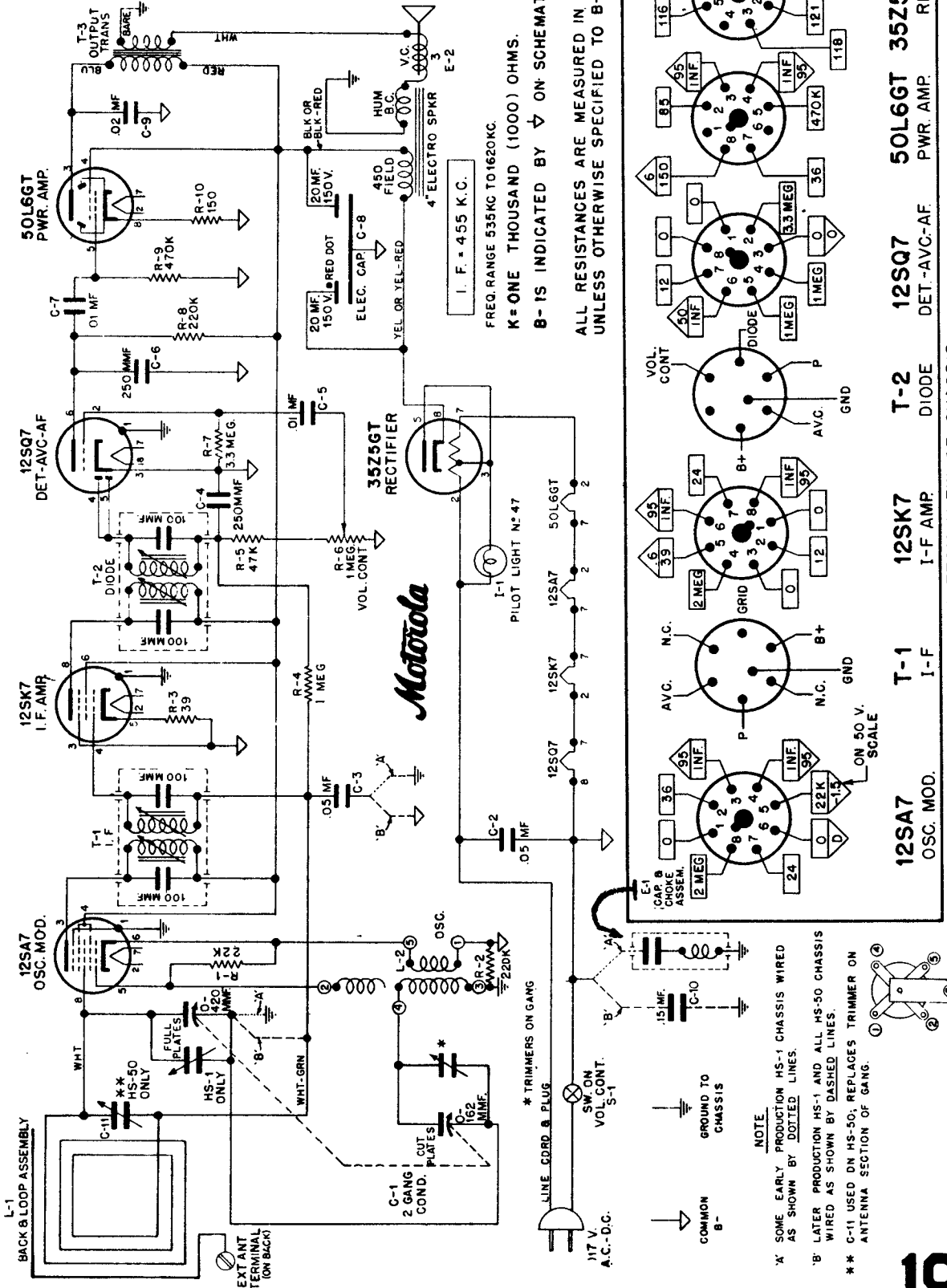

I. F. = 455 K. C.
 FREQ. RANGE 535 KC TO 1620 KC.
 K = ONE THOUSAND (1000) OHMS.
 B - IS INDICATED BY ▽ ON SCHEMATIC DIAG.
 ALL RESISTANCES ARE MEASURED IN OHMS
 UNLESS OTHERWISE SPECIFIED TO B -.

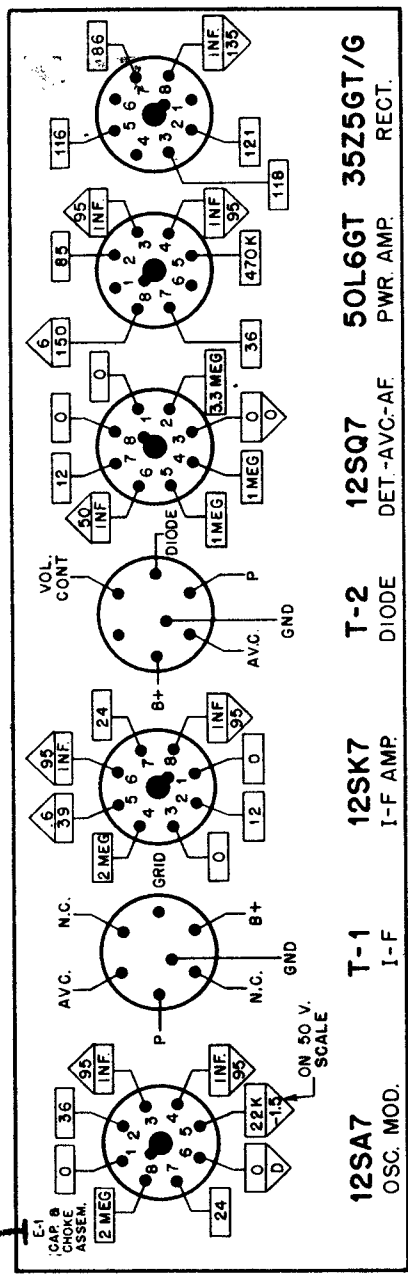

BOTTOM VIEW OF CHASSIS
 NOTE: ALL VOLTAGES MEASURED ON A 20,000 OHM PER VOLT VOLTMETER TO B -
 T-1 I-F OSC. MOD.
 T-2 DIODE
 T-3 DET.-AVC-AF
 12SA7 OSC. MOD.
 12SK7 I-F AMP.
 12SQ7 DET.-AVC-AF
 50L6GT PWR. AMP.
 35Z5GT/G RECT.
 □ = RESISTANCE MEASUREMENTS
 ▽ = VOLTAGE MEASUREMENTS

* TRIMMERS ON GANG
 * SOME EARLY PRODUCTION HS-1 CHASSIS WIRED AS SHOWN BY DOTTED LINES.
 * LATER PRODUCTION HS-1 AND ALL HS-50 CHASSIS WIRED AS SHOWN BY DASHED LINES.
 * C-11 USED ON HS-50; REPLACES TRIMMER ON ANTENNA SECTION OF GANG.
 NOTE:
 CAP & CHOKE ASSEMBLY
 ON 50 V. SCALE
 COMMON B -
 GROUND TO CHASSIS
 SW. ON VOL. CONT. S-1
 LINE CORR. & PLUG
 117 V. A.C.-D.C.
 BRACKET VIEW OF OSC. COIL L-2

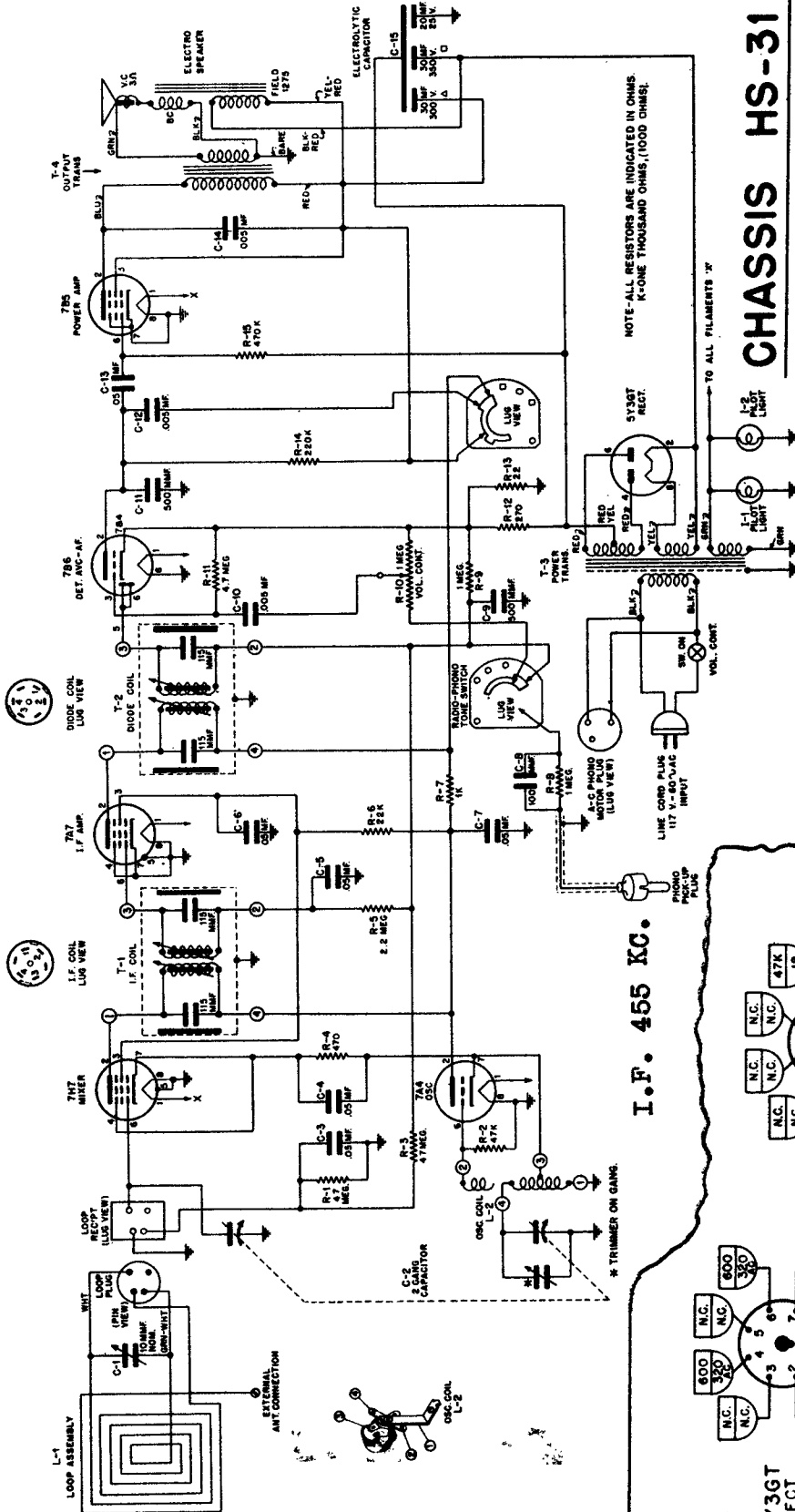

CHASSIS HS-31

MODELS 65F11 and 65F12



NOTE: A VTVM WAS USED TO MAKE MEASUREMENTS. IF A 20,000 OHM PER VOLT METER IS USED ALL GRID & AVG VOLTAGES WILL READ LOWER.

MEASUREMENTS ARE MADE FROM TUBE BASE PIN TERMINALS TO CHASSIS.

PHONO-RADIO SWITCH IN RADIO POSITION. VOLUME CONTROL ON FULL, DIAL SET TO L. F. END AND NO STATION TUNED IN.

VOLTAGE TOLERANCE ± 10%.
RESISTANCE TOLERANCE ± 20%.
= RESISTANCE MEASUREMENTS.
= VOLTAGE MEASUREMENTS.

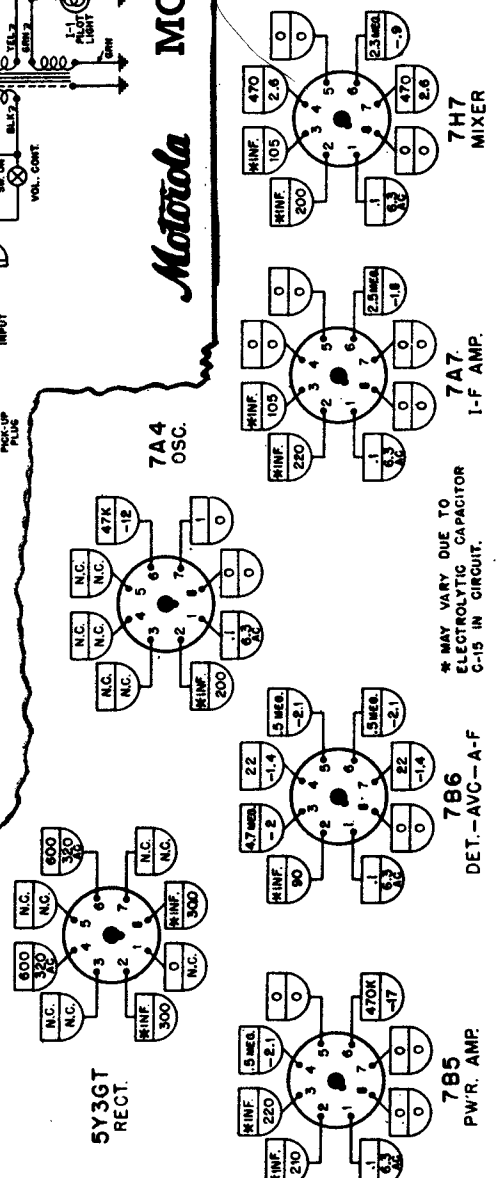

MANUAL OF 1947 MOST-OFTEN-NEEDED RADIO DIAGRAMS

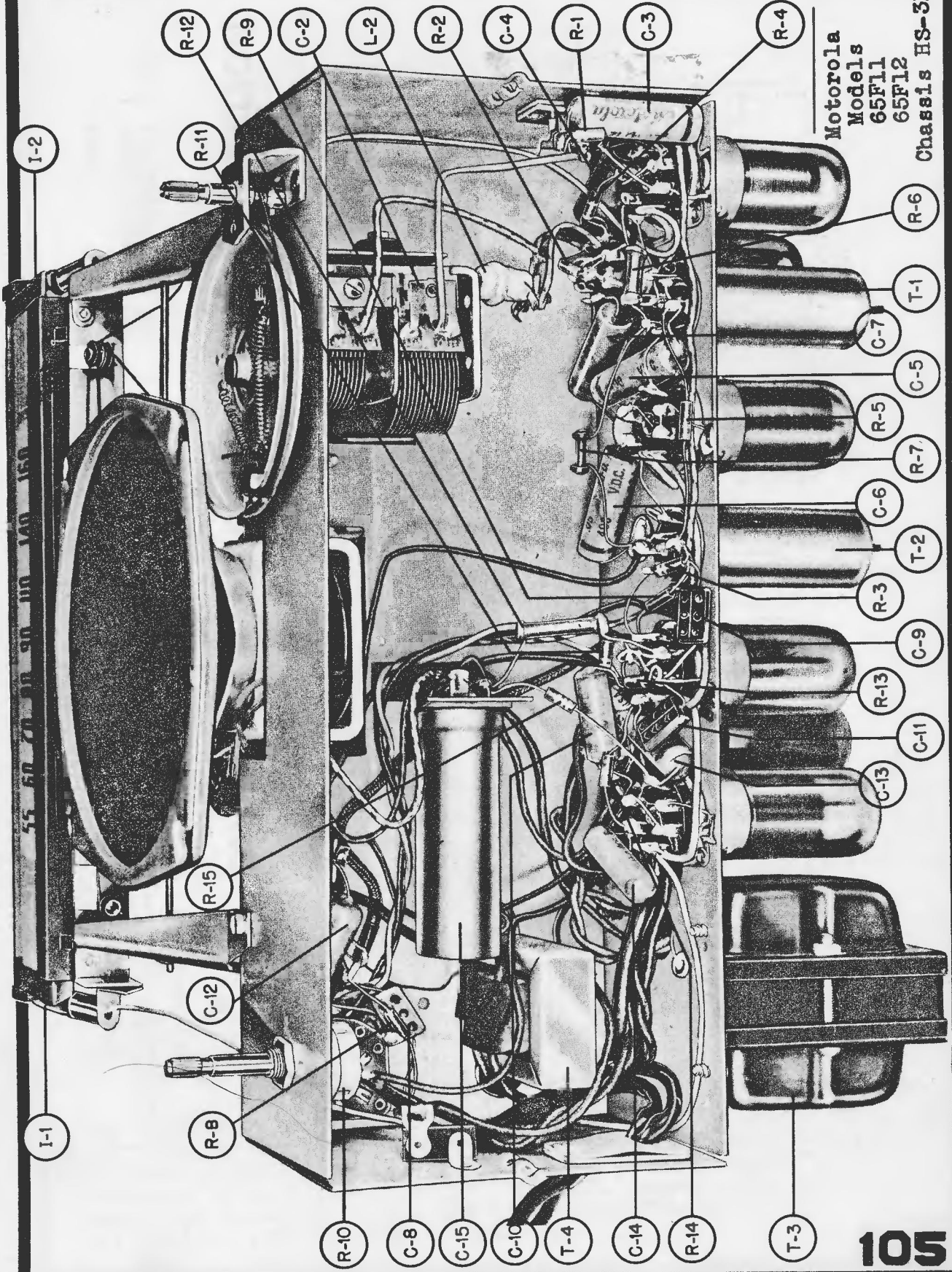

GALVIN MANUFACTURING CORPORATION

CHASSIS
HS-32
HS-67

MODELS 65T21 AND 65T21B



NOTE - ALL RESISTORS ARE INDICATED IN OHMS.
K=ONE THOUSAND OHMS, (1,000 OHMS)

1-F-455 KC
BC-1620-535 KC
SW-12.2-5.6 MC

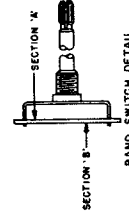
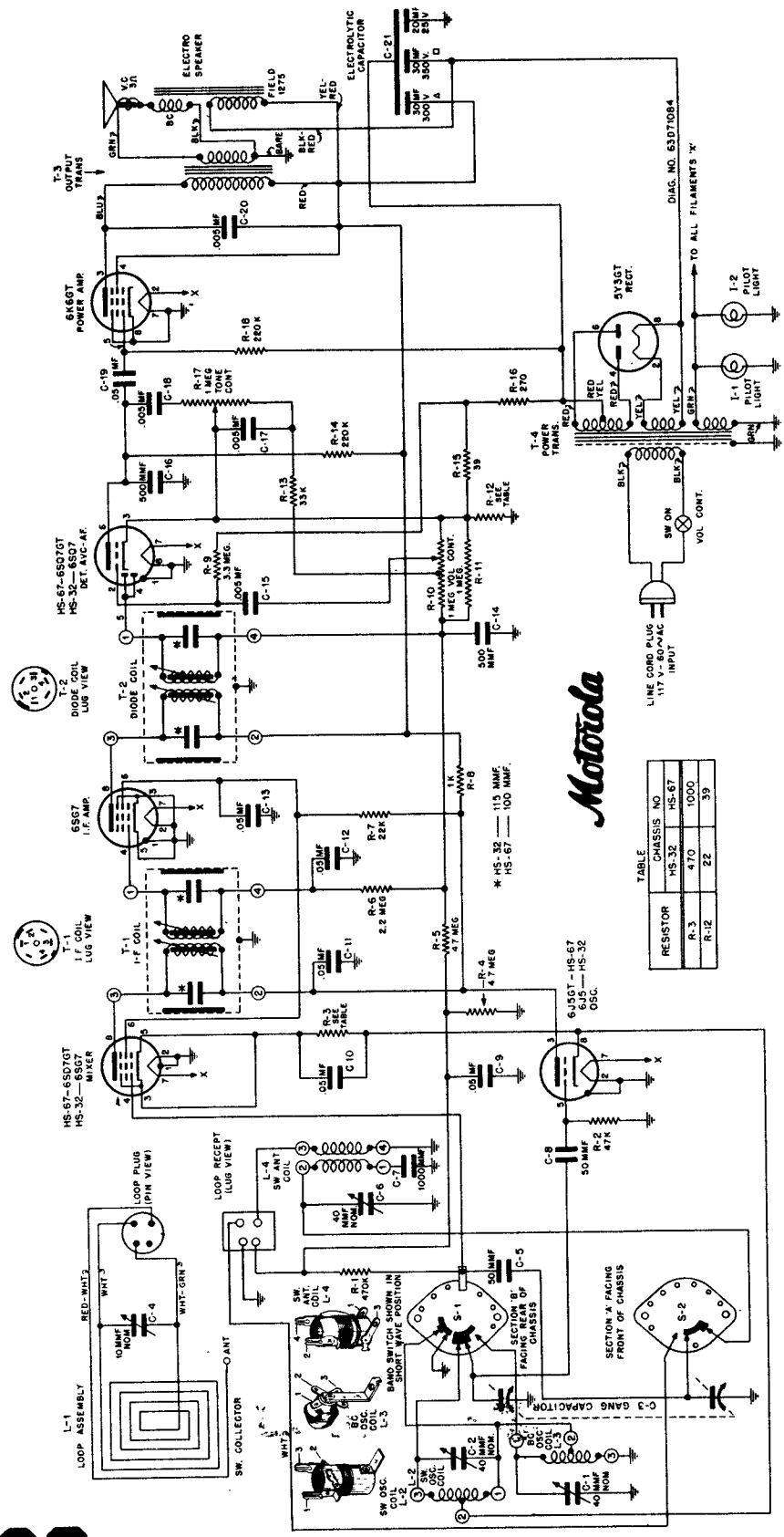

BAND SWITCH DETAIL



MANUAL OF 1947 MOST-OFTEN-NEEDED RADIO DIAGRAMS

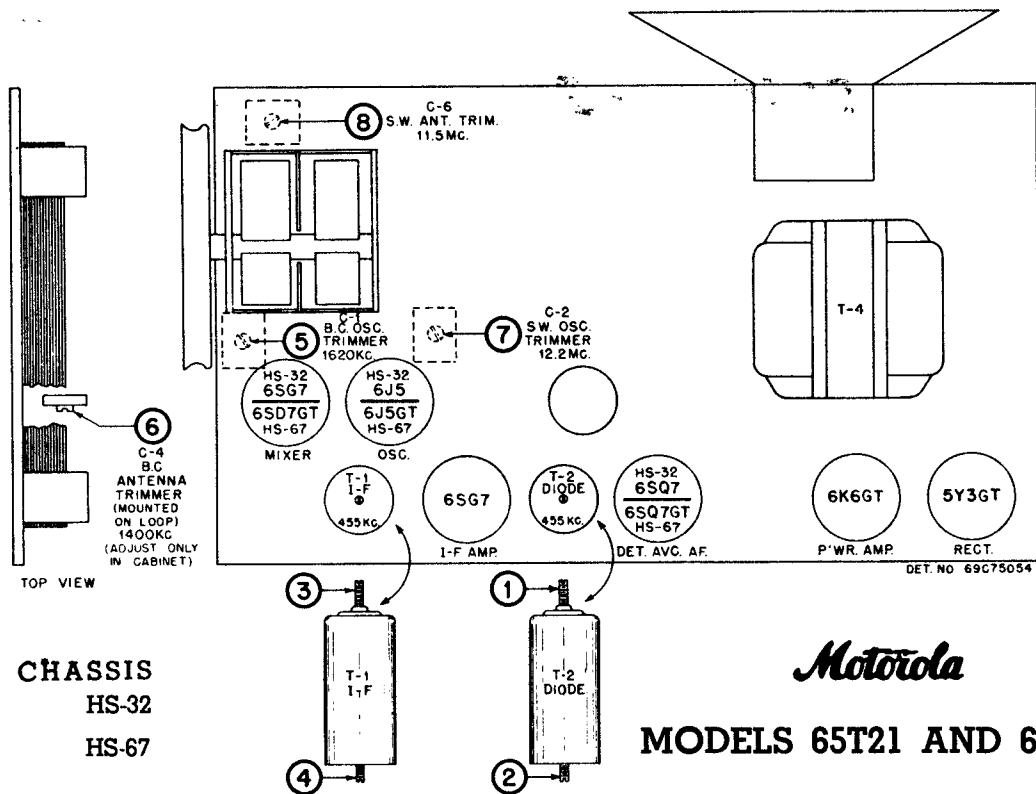

ALIGNMENT AND SENSITIVITY CHART

Connect output meter across speaker voice coil (.38V = .05 watts)
Volume control set at maximum for all operations.

OPERATION IN ORDER	GANG CAPACITOR SET AT	BAND SWITCH SET AT	DUMMY ANTENNA	GENERATOR CONNECTED TO	ADJUST TRIMMER OR SET AT IRON CORE	GENERATOR SET AT (400% MODULATED)	AVERAGE INPUT FOR .38V OUTPUT
1. Adjust I. F.'s Minimum for maximum		B. C.	.1 mf	Osc. - Mod. grid	1-2-3-4	455 Kc	900 microvolts to I. F. grid 4.5 microvolts to Osc.-Mod. grid (455 Kc)
2. Set B. C. Oscillator trimmer	1620 Kc	B. C.	None	Radiation loop*	5 B. C. Osc. trimmer C-1	1620 Kc	
3. Adjust B. C. loop trimmer for maximum	1400 Kc	B. C.	None	Radiation loop*	6 B. C. loop trimmer C-4 (on loop) should be adjusted with set in cabinet	1400 Kc	6.5 microvolts to Osc.-Mod. grid through .1 mf dummy
4. Set S. W. Oscillator trimmer	12.2 Mc	S. W.	50 mmf.	Antenna terminal	7 S. W. Osc. trimmer C-2	12.2 Mc	
5. Adjust S. W.	11.5 Mc	S. W.	50 mmf.	Antenna terminal	8 S. W. Antenna trimmer C-6	11.5 Mc	5 microvolts to Antenna terminal
6. Repeat above steps for maximum accuracy							.045 volt to 1st A. F. grid (400% cycle audio)

*Connect signal generator to a 5" dia., 3 turn loop. Distance between loops always over 12". Adjust distance and generator output to maintain output of 50 milliwatts (.38v on output meter).

MANUAL OF 1947 MOST-OFTEN-NEEDED RADIO DIAGRAMS

Galvin Manufacturing Corporation

Motorola Models 65T21 and 65T21B

Chassis HS-32 & HS-67

Circuit diagram on previous page.

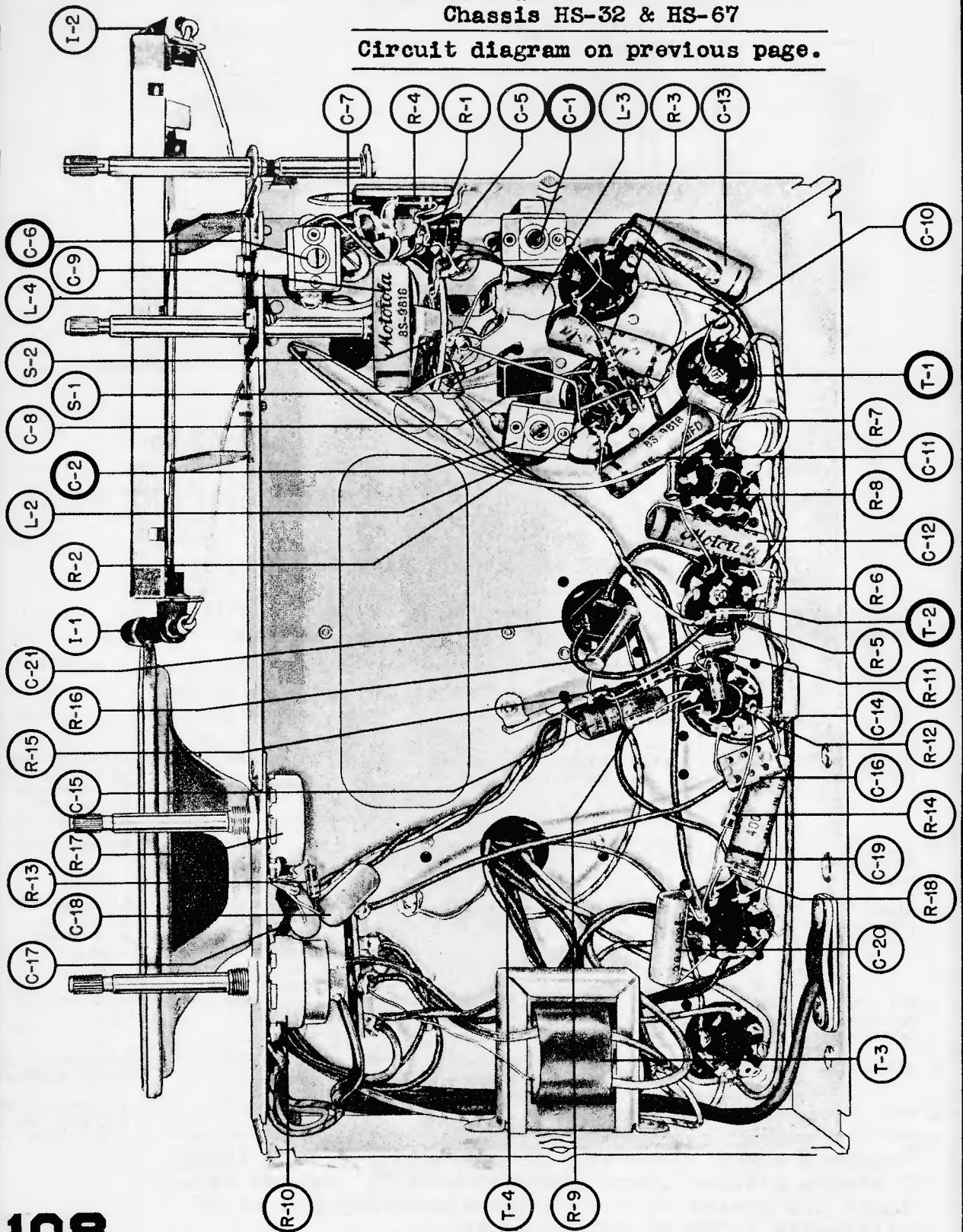

GALVIN MANUFACTURING CORPORATION

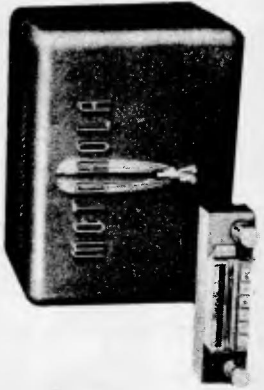
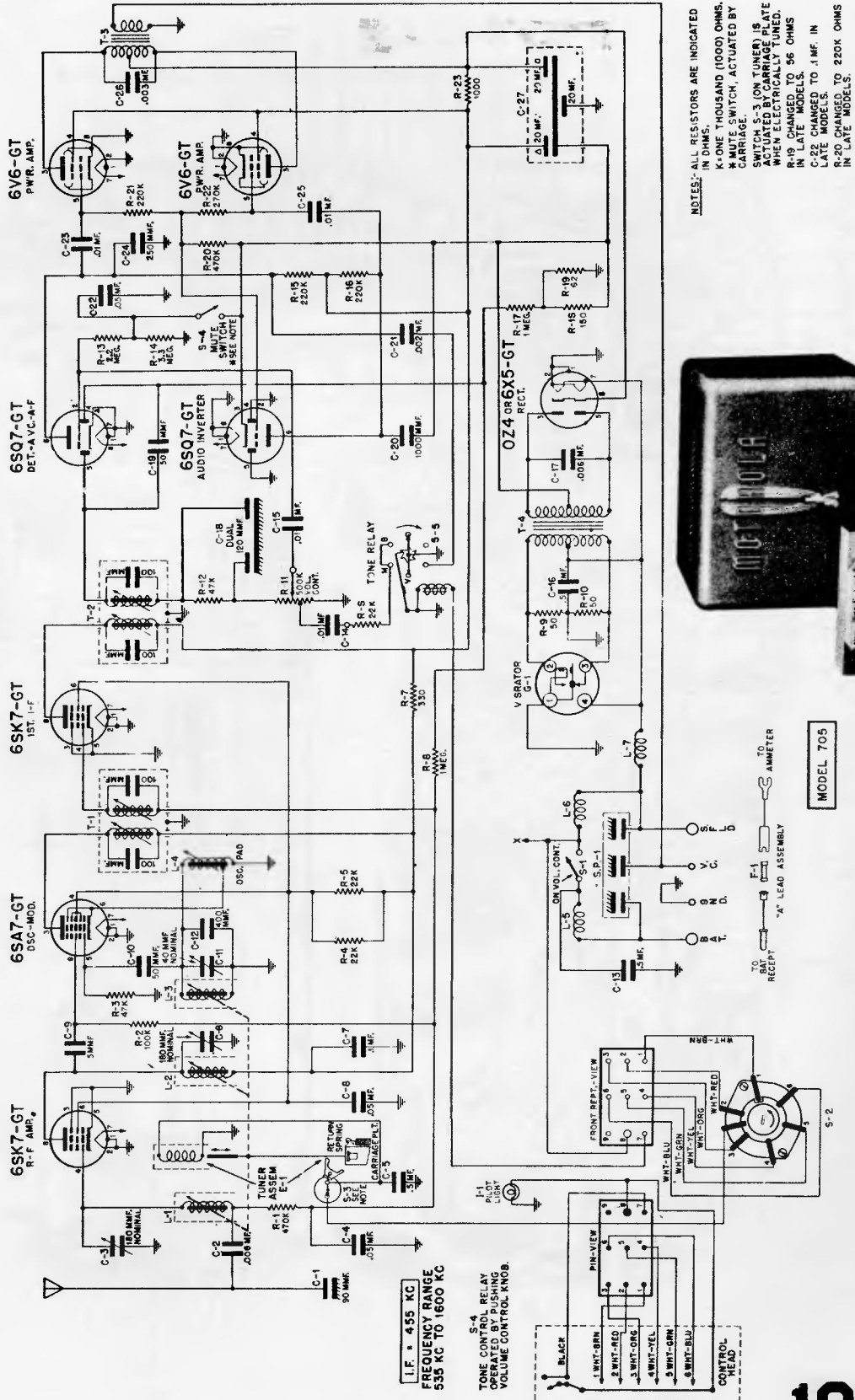

MANUAL OF 1947 MOST-OFTEN-NEEDED RADIO DIAGRAMS

Motorola Model 705 Auto Radio *- Circuit on previous page.

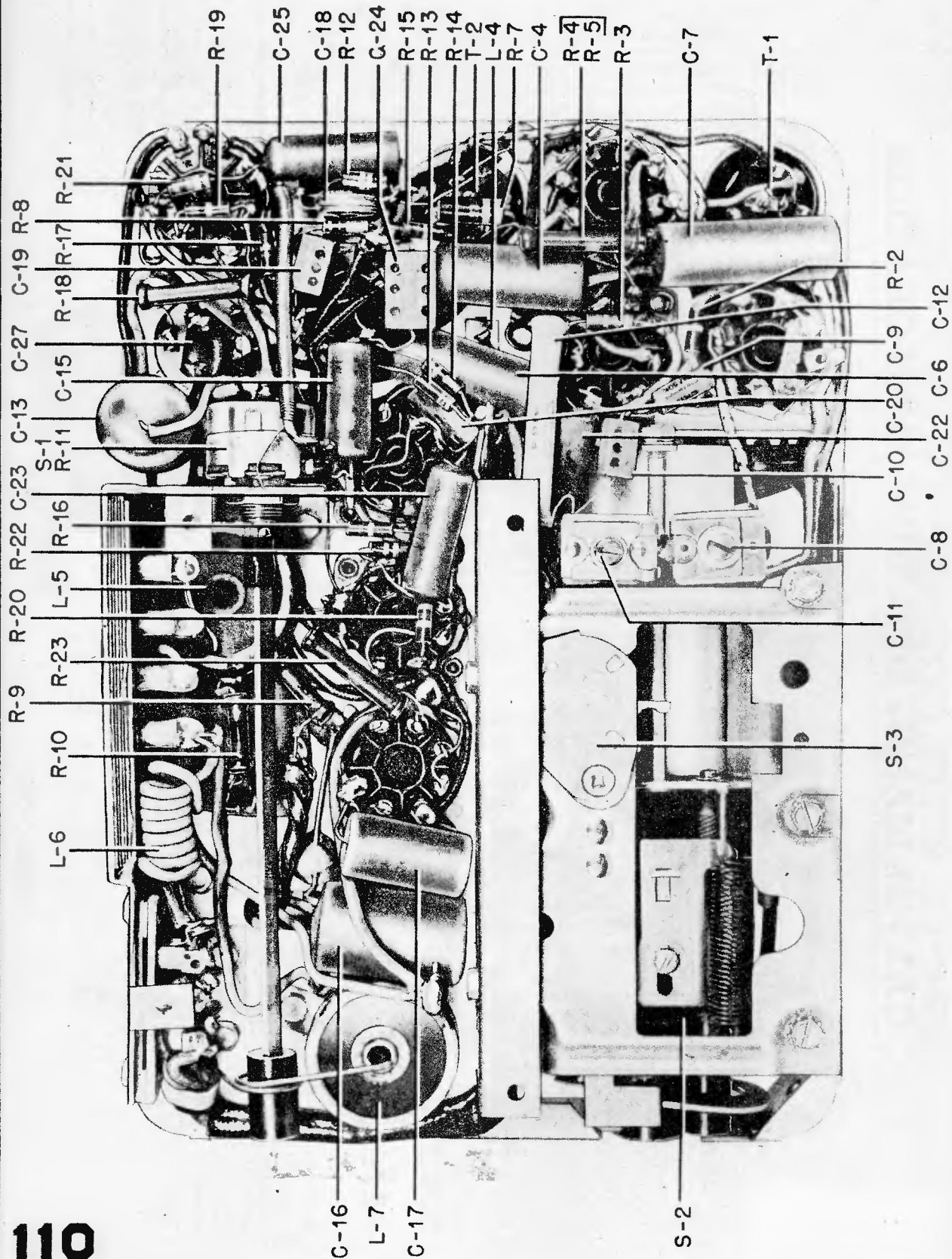

MANUAL OF 1947 MOST-OFTEN-NEEDED RADIO DIAGRAMS

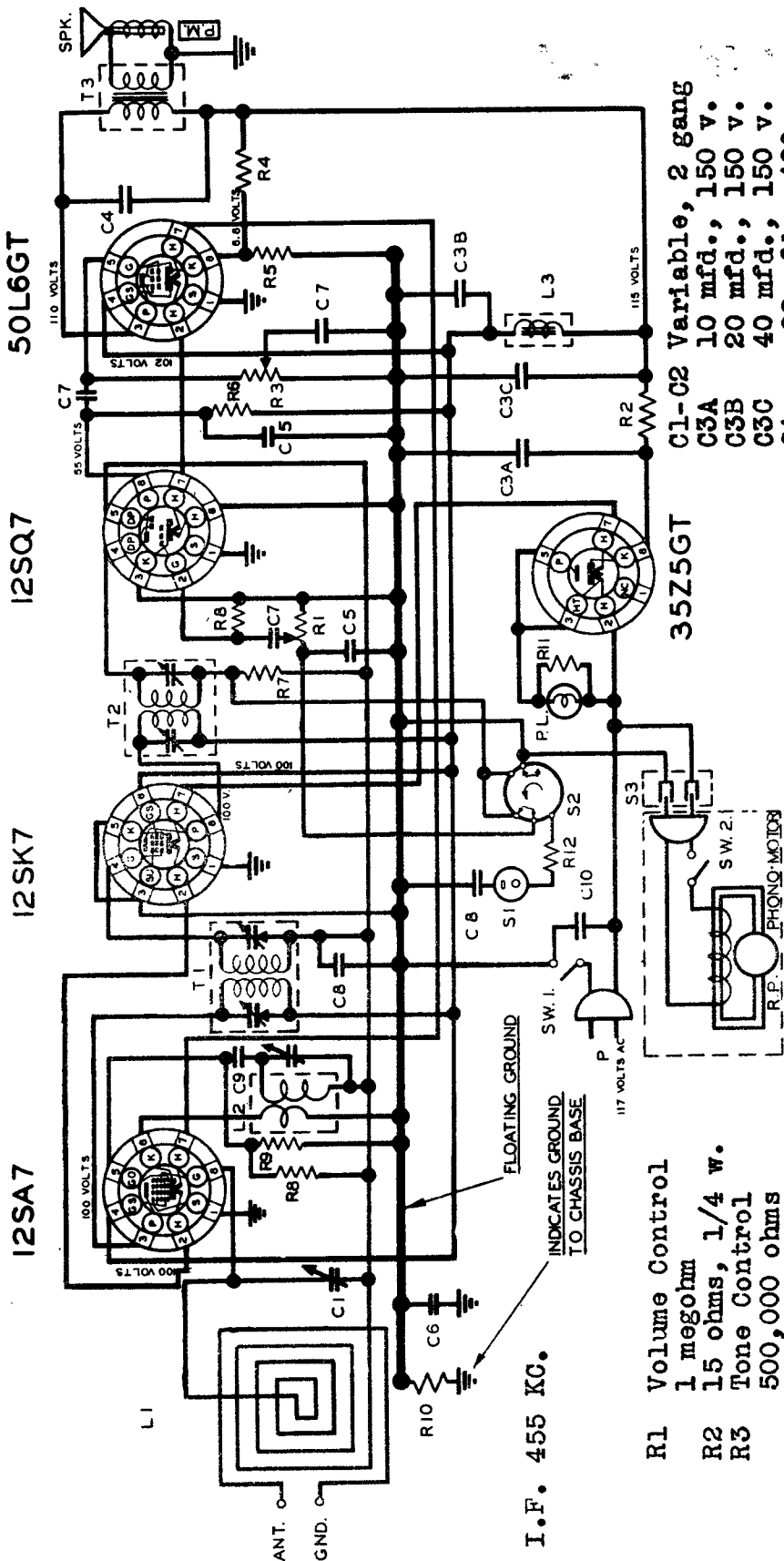

- C1-C2 Variable, 2 gang
- C3A 10 mfd., 150 v.
- C3B 20 mfd., 150 v.
- C3C 40 mfd., 150 v.
- C4 .02 mfd., 400 v.
- C5 500 mmfd., 500 v.
- C6 .2 mfd., 400 v.
- C7 .002 mfd., 600 v.
- C8 .05 mfd., 200 v.
- C9 50 mmfd., 500 v.
- C10 .05 mfd., 400 v.

TUBE SOCKETS ARE VIEWED FROM UNDER SIDE OF CHASSIS.
 VOLTAGE READINGS SHOWN AT SOCKET PRONGS ARE TO FLOATING GROUND AND ARE TAKEN WITH NO SIGNAL.
 A.C. LINE VOLTAGE AT 117 VOLTS. WHERE NO READING IS GIVEN, THE VOLTAGE IS ZERO OR TOO LOW TO READ.

- R1 Volume Control 1 megohm
- R2 15 ohms, 1/4 w.
- R3 Tone Control 500,000 ohms (Early sets used 50,000 ohms in plate circuit)
- R4 12,000, 1 watt
- R5 150 ohms, 1/4 w.
- R6 470,000, 1/4 w.
- R7 2.2 megohms, "
- R8 15 megohms, "
- R9 22,000 ohms, "
- R10 330,000 ohms
- R11 680 ohms, 1/4 w.
- R12 1 megohm, 1/4 w.

ARVIN RADIO - MODEL 558 CHASSIS RE - 204
 5 TUBE AC-DC RADIO-PHONO COMBINATION
 MANUFACTURED BY NOBLITT - SPARKS INDUSTRIES, INC., COLUMBUS IND.



MANUAL OF 1947 MOST-OFTEN-NEEDED RADIO DIAGRAMS

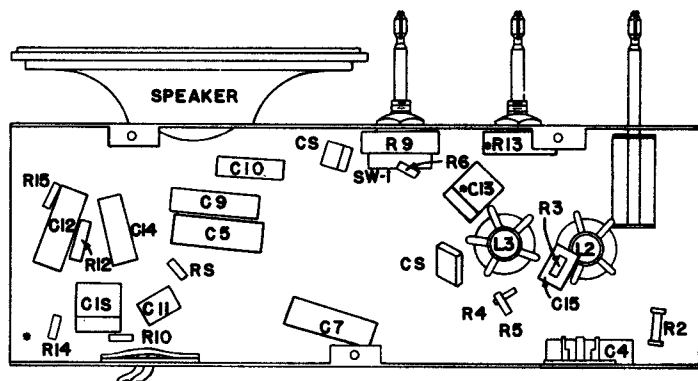

LOCATION OF PARTS UNDER CHASSIS

ARVIN RADIO

Noblitt-Sparks Industries

Models 664 & 664-A

RE-206-1

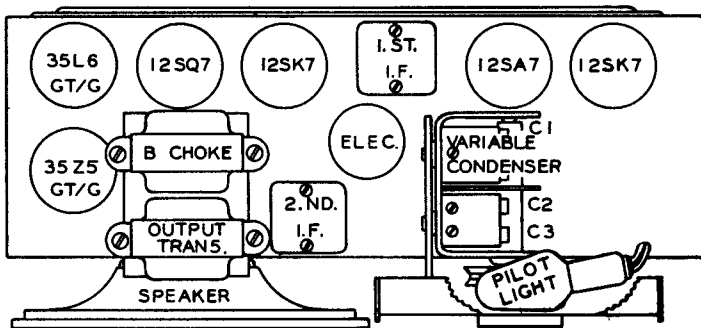

TUBE LAYOUT

Intermediate frequency—455 Kc. I-f and r-f measurements made at 200 milliwatts output—approximately .8 volt on a rectifier type voltmeter connected across the voice coil. Dummy load for r-f—50 ufd condenser in series with generator lead, or standard alignment loop. Dummy load for i-f—.05 ufd condenser in series with generator lead. To calibrate, set pointer vertical with gang closed. Trim osc. mixer and antenna circuits only at 1400 Kc.

Approximate max. sensitivities for standard output: I-f—125 uv. R-f with standard loop: at 600 Kc—150 uv/m; at 1000 Kc—125 uv/m; at 1400 Kc—75 uv/m. R-f at antenna clip: at 600 Kc—25 uv; at 1000 Kc—15 uv; at 1400 Kc 15 uv.

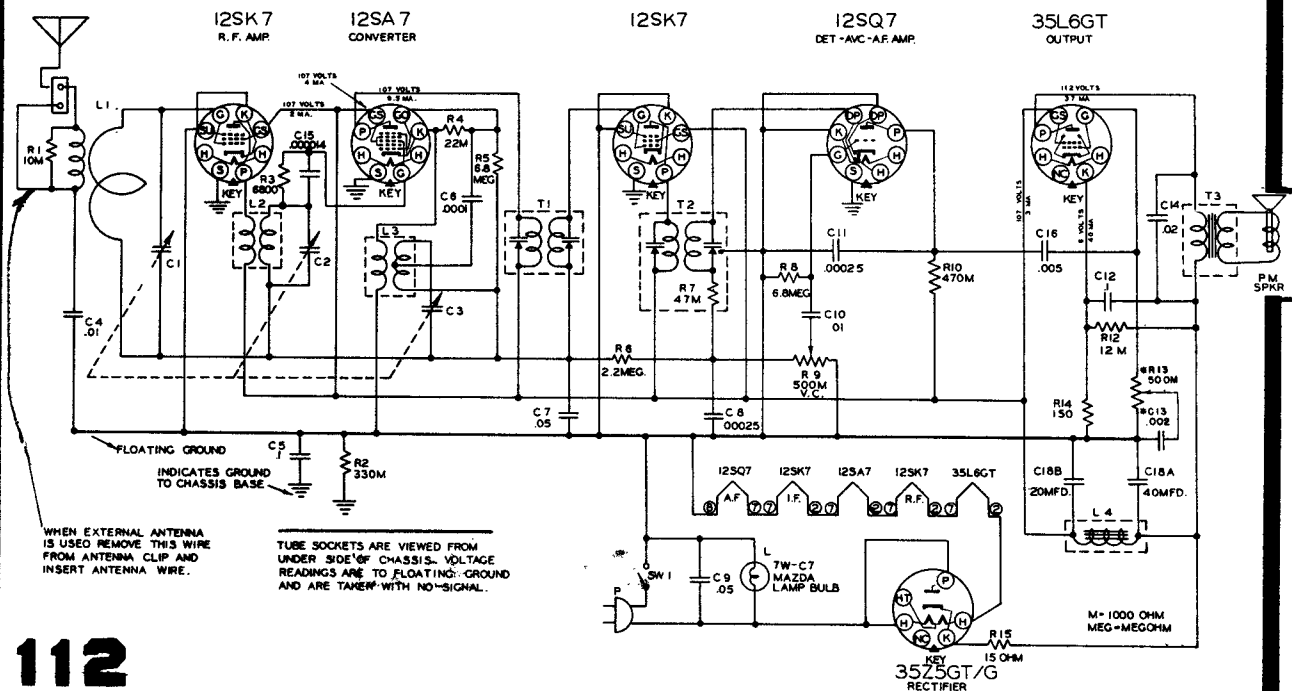

MANUAL OF 1947 MOST-OFTEN-NEEDED RADIO DIAGRAMS

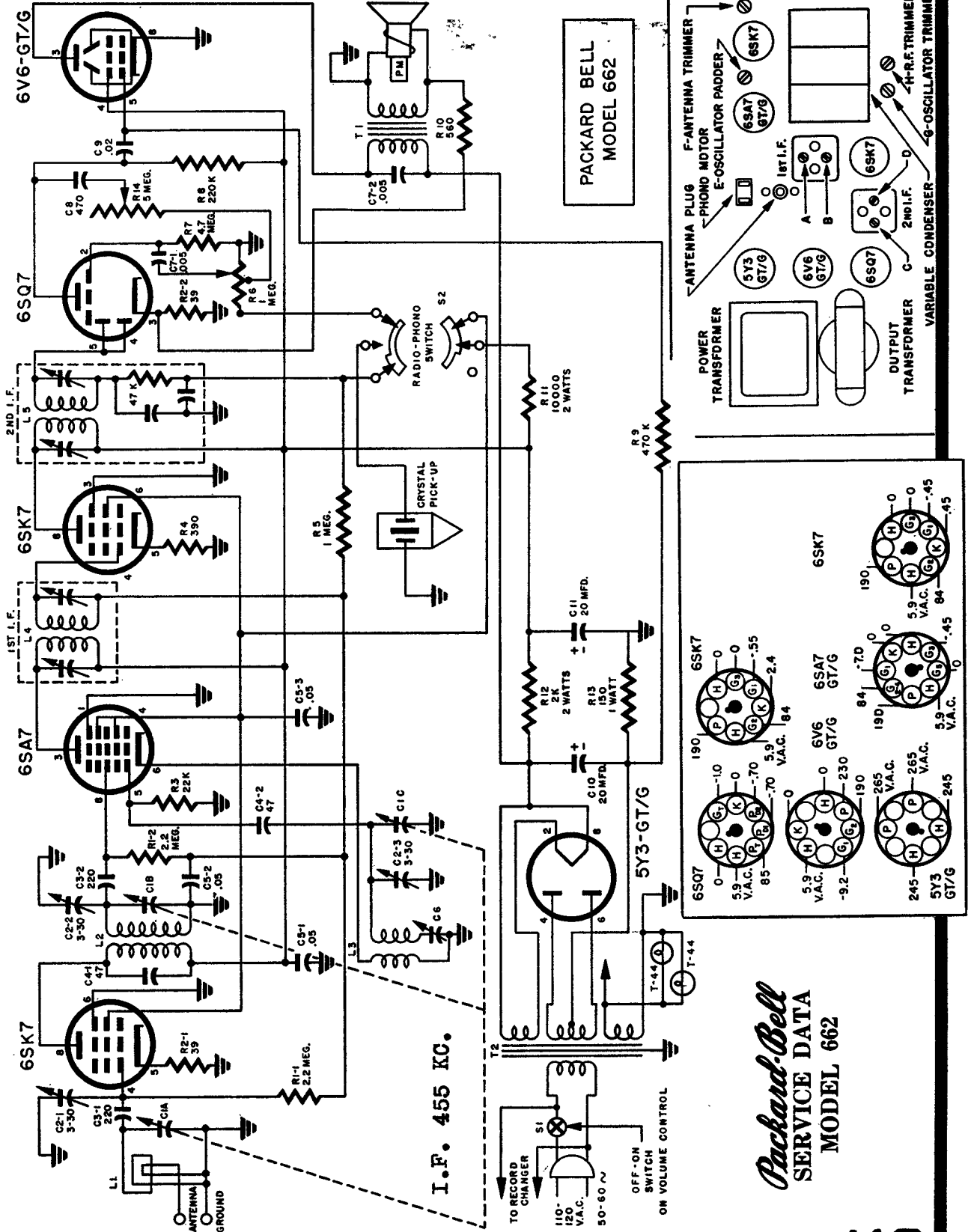

Packard-Bell
SERVICE DATA
MODEL 662

MANUAL OF 1947 MOST-OFTEN-NEEDED RADIO DIAGRAMS

MODEL 563 COMBINATION RADIO-PHONOGRAPH

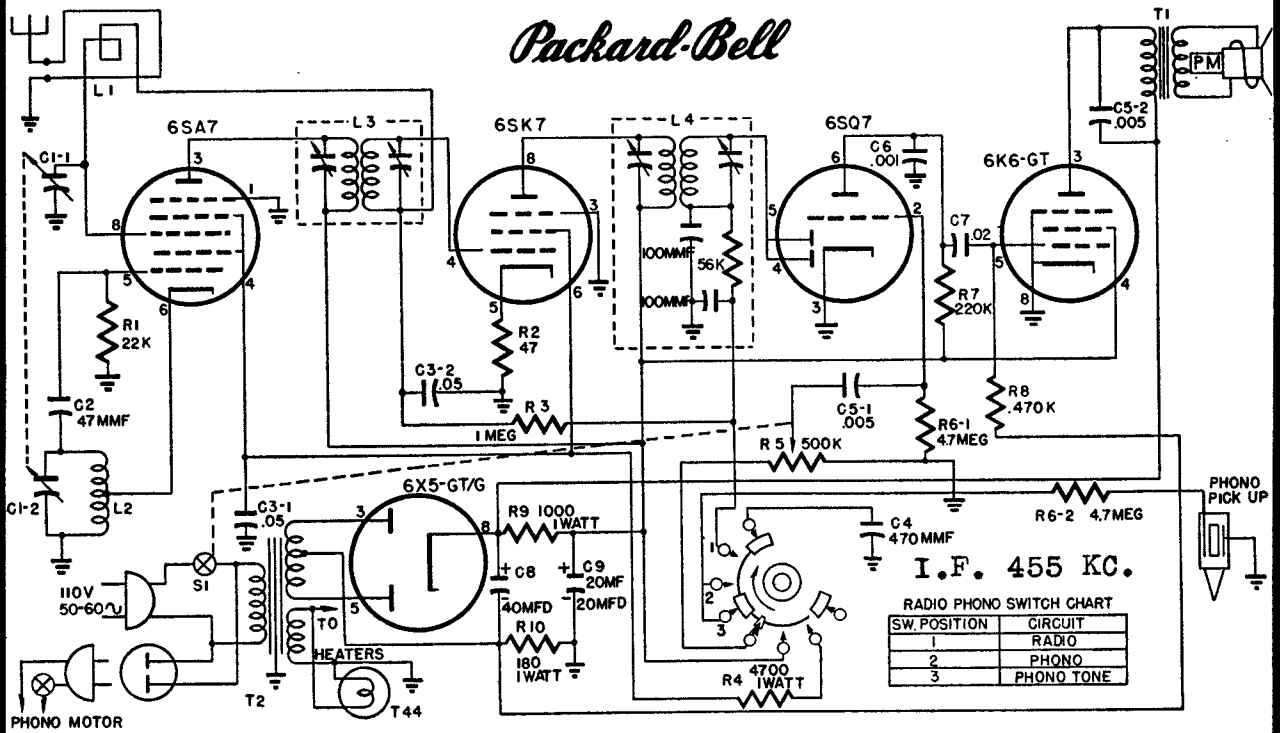

Packard-Bell

PHONOGRAPH MODEL C-1461



MODEL U-24

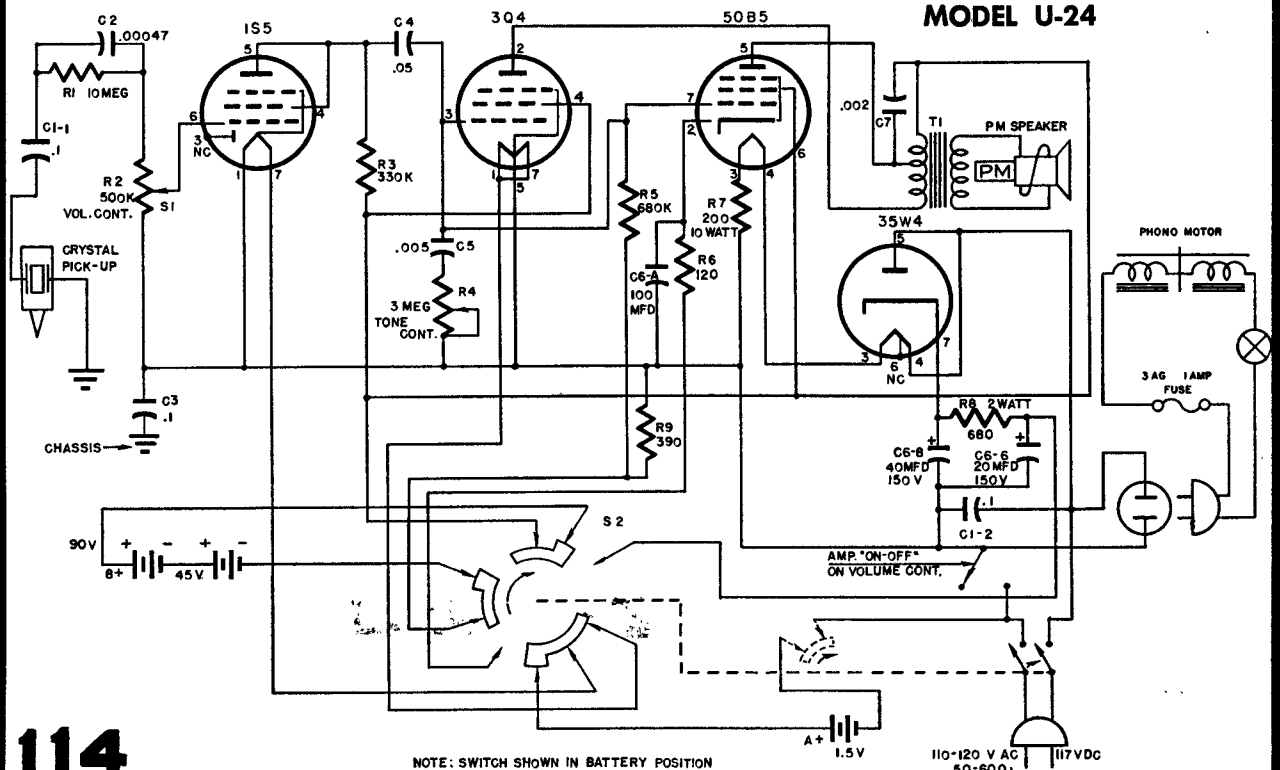

MANUAL OF 1947 MOST-OFTEN-NEEDED RADIO DIAGRAMS

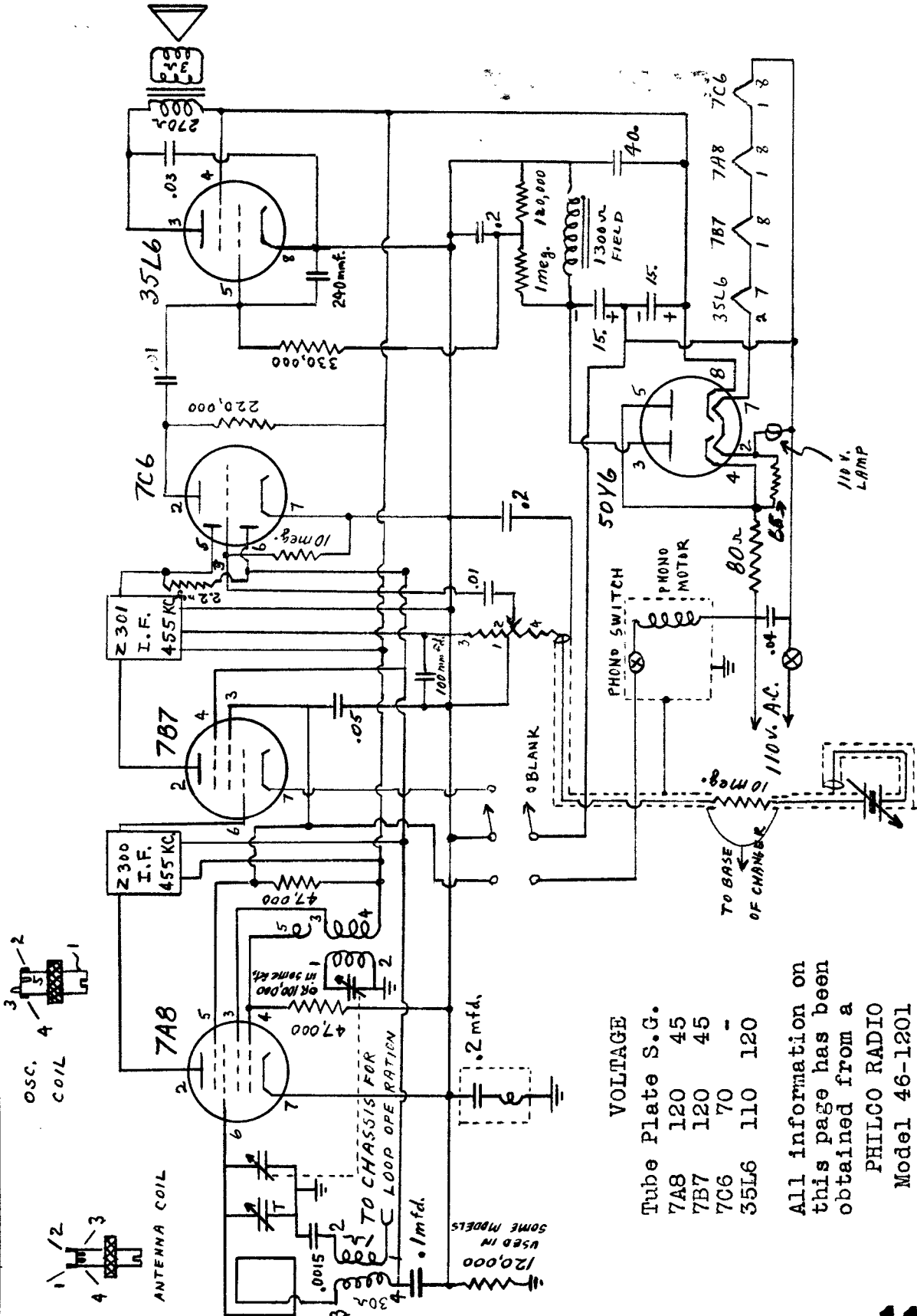

VOLTAGE

Tube	Plate S.G.	Voltage
7A8	45	120
7B7	45	120
7C6	-	70
35L6	110	120

All information on this page has been obtained from a

PHILCO RADIO
Model 46-1201

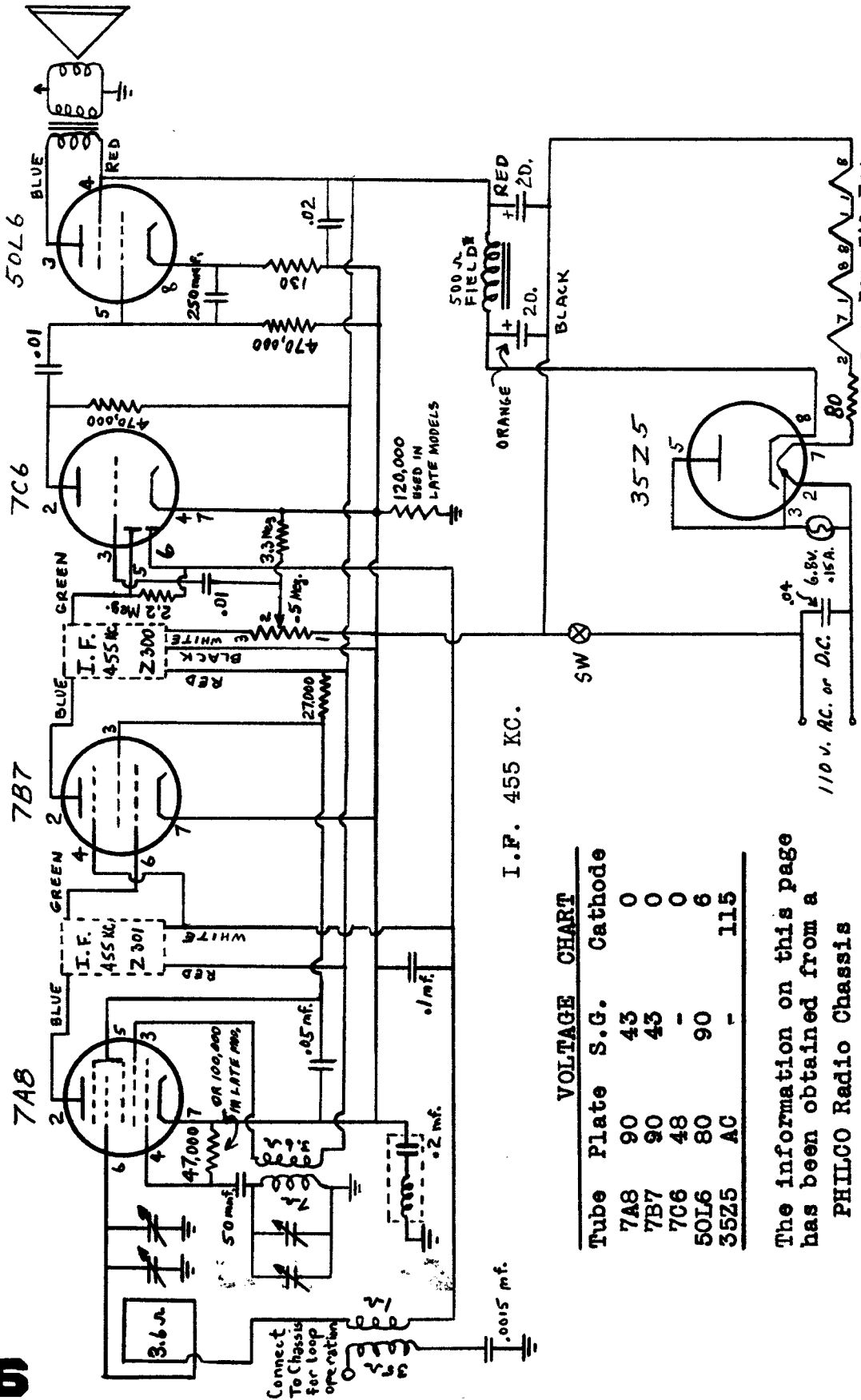

VOLTAGE CHART

Tube	Plate	S.G.	Cathode
7A8	90	43	0
7B7	90	43	0
7C6	48	-	0
50L6	80	90	6
35Z5	AC	-	115

The information on this page has been obtained from a

PHILCO Radio Chassis

used in Models 46-200, 46-201, 46-202, 46-203.

* Some later models used a PM speaker with 220 and 1200 ohm resistors instead of-the field; filter condenser 30-25-20.

MANUAL OF 1947 MOST-OFTEN-NEEDED RADIO DIAGRAMS

RCA VICTOR

64F1, 64F2, 64F3 (RC-1037) (RC1037) (RC1037A) and CV45 ELECTRIFIER (R. R. 1001) Mfr. No. 274

Alignment Procedure

Cathode Ray Alignment is the preferable method. Connections for the oscillograph are shown in the diagram.

Output Meter Alignment.—If this method is used, connect the meter across the voice coil and turn the receiver volume control to maximum.

Test Oscillator.—For all alignment operations, connect the low side of the test oscillator to the receiver chassis, and keep the output as low as possible to avoid AVC action.

Pre-Setting Dial.—With gang condenser in full mesh, the pointer should be set at the left-hand end dial calibration mark.

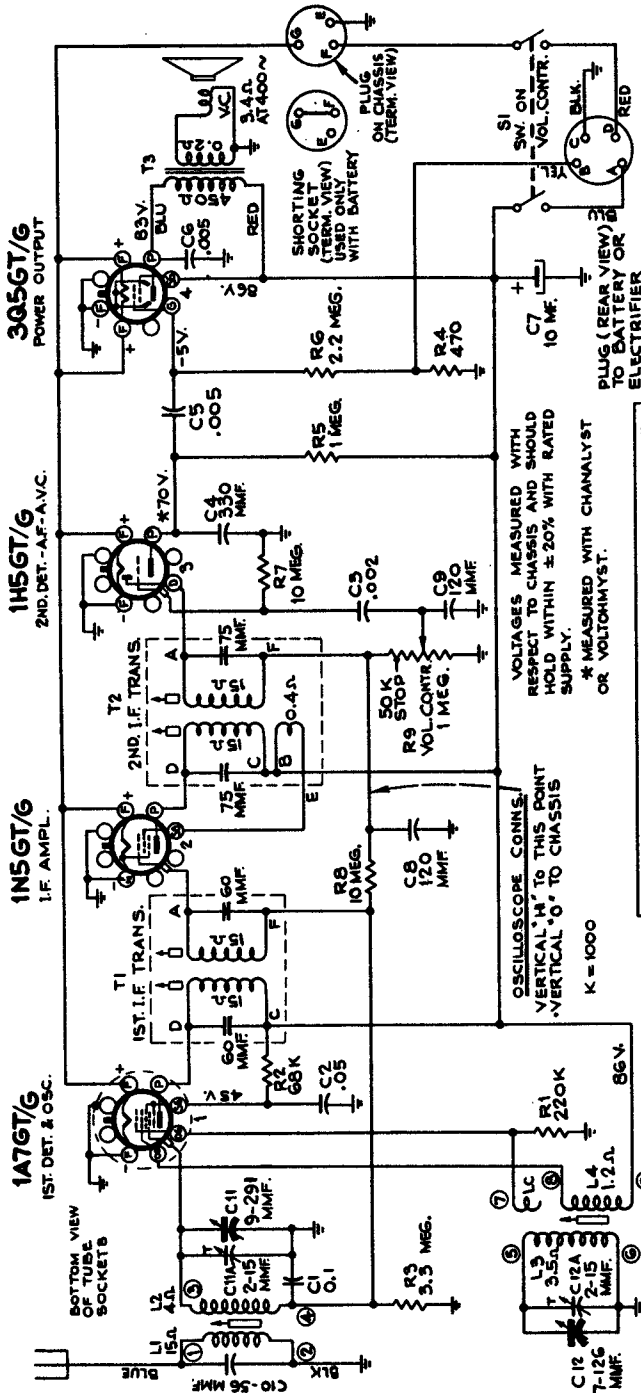

Steps	Connect high side of the test oscillator to—	Tune test osc. to—	Turn radio dial to—	Adjust following for maximum peak output
1	L.F. (IN5) grid in series with .1 mfd.	455 kc	Quist point at the low freq. end of the dial	2nd L.F. trans.*
2	1A7 grid in series with .1 mfd.			1st L.F. trans.
3	Antenna lead (blue) in series with 200 mmf.	1300 kc	1300 kc	C12A (osc.) C11A (ant.)
4		600 kc	600 kc	(Osc.) and (ant.) slugs
5	Repeat steps 3 and 4 for exact alignment.			

*Do not repeat step 1.

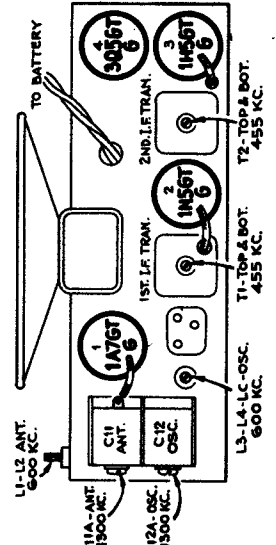
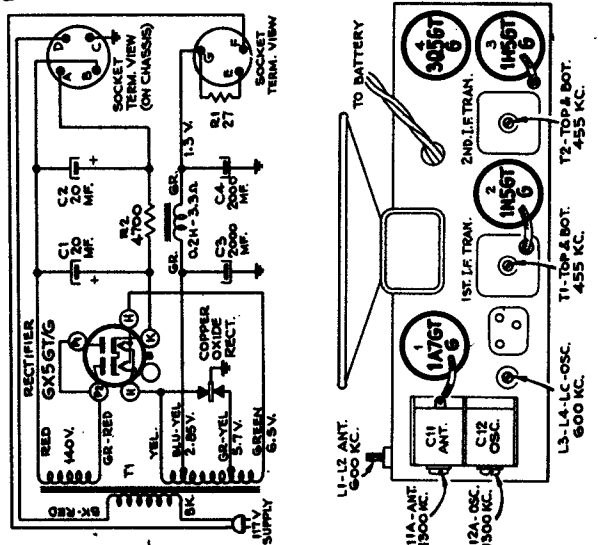

MANUAL OF 1947 MOST-OFTEN-NEEDED RADIO DIAGRAMS

RCA VICTOR

65U, 65AU

Chassis No. RC1017A

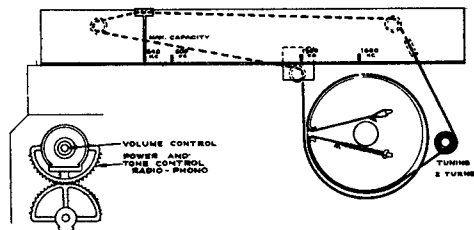

Dial Pointer Adjustment.—Rotate tuning condenser fully counter-clockwise (plates fully meshed). Adjust indicator pointer to left (max. cap.) mark on dial back plate.

CAUTION.—CLOSE TUNING CONDENSER PLATES COMPLETELY (C-C-W) BEFORE REMOVING CHASSIS FROM CABINET.

Take off both wooden strips on bottom of cabinet by removing wood-screws before loosening chassis bolts.

Test Oscillator.—Connect high side of test oscillator as shown in chart. Connect low side through a .01 mf capacitor to common "—B". Keep the output signal as low as possible to avoid a-v-c action.

Output Meter.—Connect meter across speaker voice coil. Turn volume control clockwise to radio maximum high position (3) for alignment.

Steps	Connect the high side of test-oscillator to—	Tune test-osc. to—	Turn radio dial to—	Adjust the following for max. peak output
1	I.F. grid in series with .01 mfd.	455 kc	Quiet point 1,600 kc end of dial	L8 and L9 2nd I.F. transformer
2	1st Det. grid in series with .01 mfd.			L6 and L7 1st I.F. transformer *
NOTE.—ANTENNA LOOP AND RECORD CHANGER MUST BE IN CABINET				
3	Antenna terminal in series with 220 mmfd.	1600 kc	Gang at minimum	C19 (osc.)
4	Radiated signal 1300 kc		Signal Frequency	C17 (ant.)
5	Repeat steps 3 and 4.			

*Do not readjust L8 or L9 when test oscillator is connected to 1st Det.

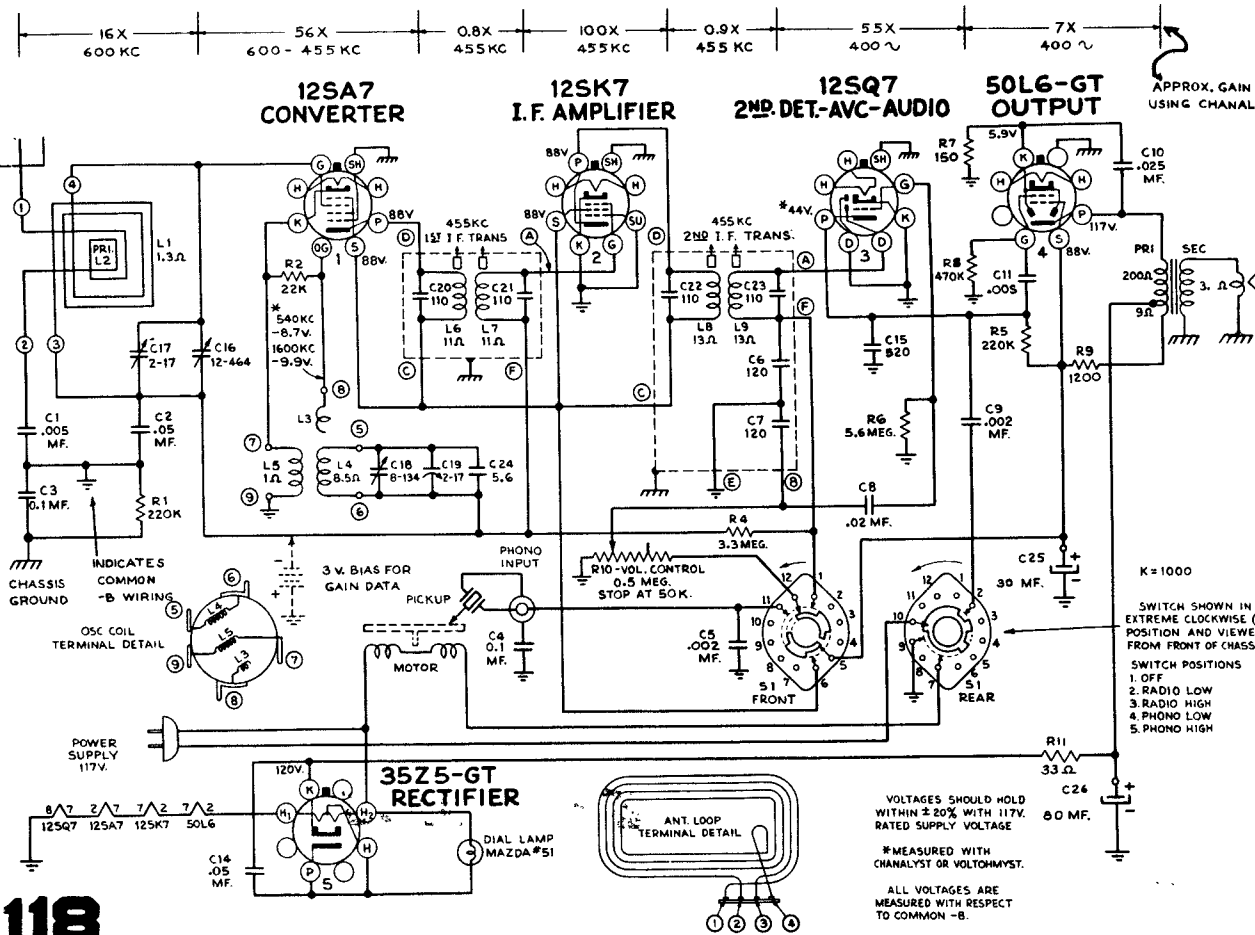
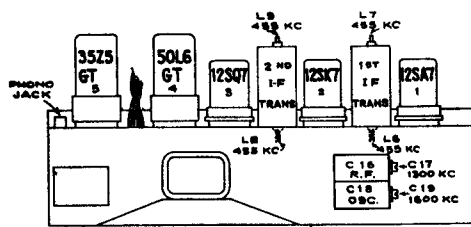

MANUAL OF 1947 MOST-OFTEN-NEEDED RADIO DIAGRAMS

Radiola Model 66-1 (RC-1004E)

Alignment Procedure

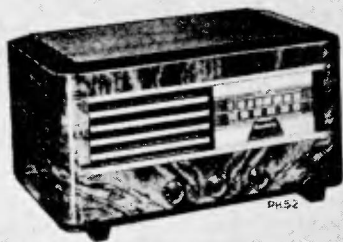

Model 66-1

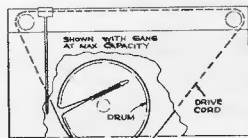

Dial Cord Assembly

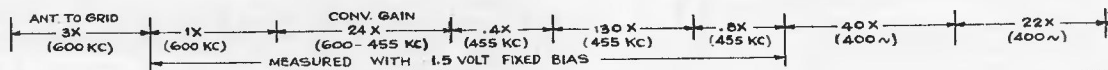
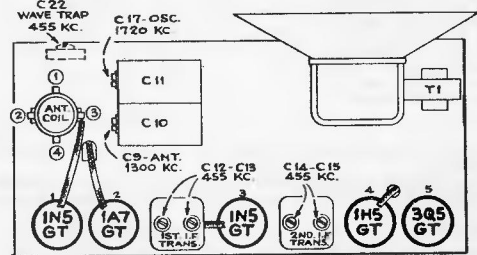

Cathode Ray Alignment is the preferable method. Connections for the oscillograph are shown in the diagram.

Output Meter Alignment.—If this method is used, connect the meter across the voice coil and turn the receiver volume control to maximum.

Test Oscillator.—For all alignment operations, connect the low side of the test oscillator to the receiver chassis, and keep the output as low as possible to avoid AVC action.

Pre-Setting Dial.—With gang condenser in full mesh, the pointer should be set at the left-hand end calibration mark.

Step	Connect high side of the test oscillator to—	Tune test osc. to—	Turn radio dial to—	Adjust the following for maximum peak output
1	I-F grid in series with .01 mfd.	455 kc	Quiet point between 550 and 750 kc	C14, C15 (2nd I-F Trans.)
2	1A7GT grid in series with .01 mfd.			C12, C13 (1st I-F Trans.)
3		1,720 kc	Tuning condenser rotor plates all out	C17 (osc.)
4	Antenna terminal in series with 200 mmfd.	1,300 kc	1,300 kc signal	C9 (ant.)
5		455 kc	Quiet point between 550 and 750 kc	Adjust C22 for minimum output on strong 455 kc signal

Precautionary Lead Dress.—

1. The lead from the 3Q5 plate to output transformer should be dressed under clip and away from audio input leads.
2. All filament wires should be dressed close to chassis.
3. Keep AVC lead connecting C1 (0.1 mfd. filter) to antenna coil away from the 1A7GT plate.
4. Keep blue plate leads coming from I.F. transformers short and close to chassis.
5. Keep yellow leads connected to oscillator coil away from trap coil.
6. Keep grid lead of 1N5GT RF tube away from 1A7GT grid.
7. Keep green lead from second I.F. transformer short and close to ground.

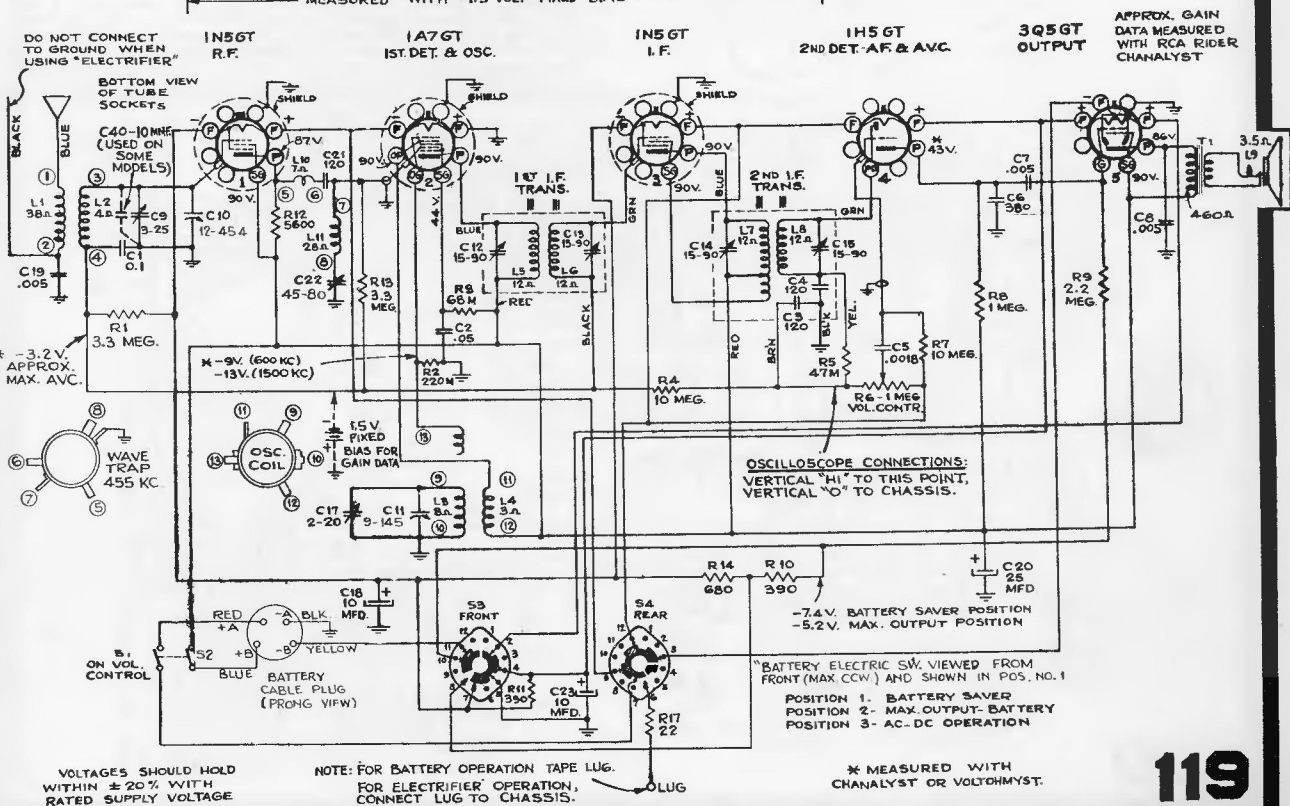

MANUAL OF 1947 MOST-OFTEN-NEEDED RADIO DIAGRAMS

66BX PORTABLE

Chassis No. RC-1040; RC-1040A

Alignment Procedure

Cathode Ray Alignment is the preferable method. Connections for the oscilloscope are shown on the schematic diagram.

Output Meter Alignment.—If this method is used, connect the meter across the voice coil and turn the receiver volume control to maximum.

Test Oscillator.—For all alignment operations, connect the low side of the test oscillator to the receiver chassis and keep the oscillator output as low as possible to avoid AVC action.

Calibration Scale.—The calibrated dial scale is permanently connected to chassis. It can therefore be used directly as a reference for alignment.

With the gang at full mesh set the dial pointer so that the left hand edge of the pointer is $\frac{1}{4}$ inches to the right of the point indicated in the dial cord drawing.

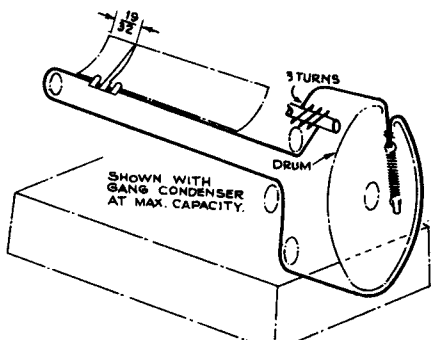
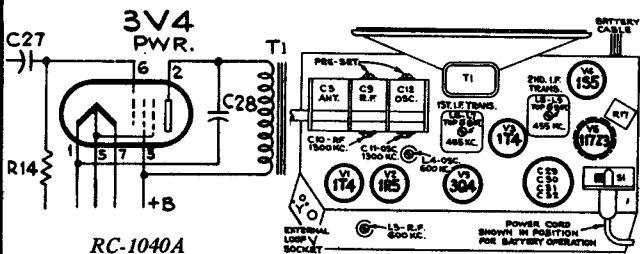
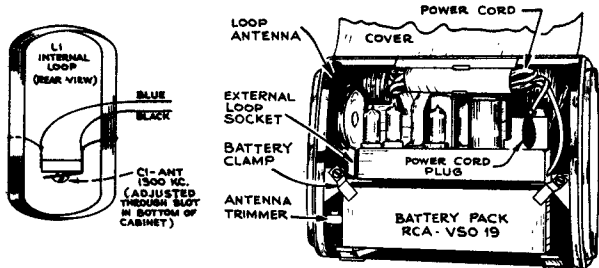

Steps	Connect the high side of test-oscillator to—	Tune test-osc. to—	Turn radio dial to—	Adjust the following for max. peak output
1	High side of loop (Blue lead) in series with 0.1 mfd.	455 kc	Gang at max. cap.	L5, L9 (2nd I.F. Trans.)* L6, L7 (1st I.F. Trans.)
2	High side of loop (Blue lead) in series with 0.1 mfd. (Bottom shield cover in place and chassis out of cabinet)	1300 kc	1300 kc	C11—(osc.) C10—(R.F.)
3		600 kc	600 kc	L4 (osc.) L3 (R.F.)
** 4	220 mmf. in series with a single turn loop 4x2 in., approx. 3 in. from receiver loop. (Chassis in cabinet C-1 connected and rear lid of cabinet closed)	1300 kc	1300 kc	C1 (loop)

*If two peaks are found with top slugs use the one with stud in the outer position.

**Adjust C-1 loop cap with back cover of case closed. Access to trimmer is made through small slot in case provided for cable of external loop.

AC-DC Operation.

This receiver will operate on 105 to 125 volts, AC 50 or 60 cycles, or DC.

A power cord is stored in the fiber tube which is clamped above the chassis inside the cabinet. To open the cabinet, slide the two plastic feet in the rear of the cabinet toward each other, and raise the back cover upward on its hinges. Then pull the power cord plug out of the socket on the top of the chassis as shown, and take out and unroll the power cord. A slot in the bottom of the cabinet allows the closing of the cabinet with the power cord passing through. Close the cabinet with the cord extending through the slot and insert the plug into a convenient electrical outlet.

When returning to battery operation, be sure to replace the power plug in its socket inside the case with the cord stored in the fiber tube.

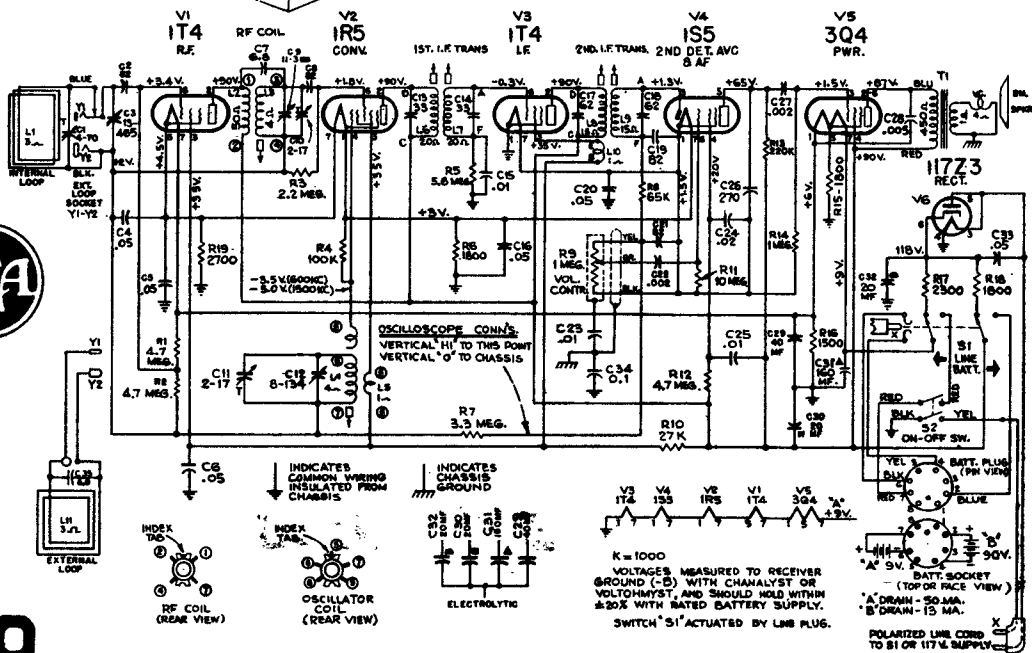

MANUAL OF 1947 MOST-OFTEN-NEEDED RADIO DIAGRAMS

Alignment Procedure

RCA VICTOR

MODELS 66X1, 66X2, 66X3, 66X4, 66X9

Chassis No. RC-1038

Test Oscillator.—Connect high side of test oscillator as shown in chart. Connect low side through a 0.1-mf. capacitor to common “-B.” Keep the output signal as low as possible to avoid A.V.C. action.

Output Meter.—Connect meter across speaker voice coil. Turn volume control to maximum clockwise position, station selector switch to broadcast maximum high position (pos. 2), for broadcast alignment and to position 3 for high frequency band.

Dial Pointer Adjustment.—Rotate tuning condenser fully counter-clockwise (plates fully meshed). Adjust indicator to 2 1/4 in. from end of backplate as indicated in drawing.

On models 66X1 and 2 the dial indicator is accessible for adjustment by removing the metal strip below the dial glass. (Lift and swing the top forward).

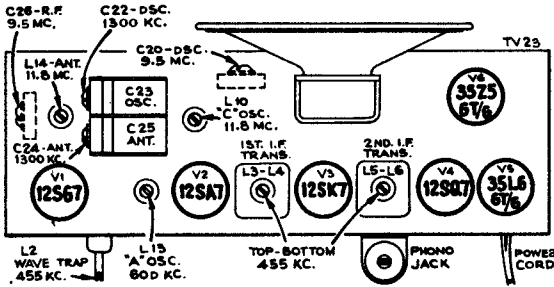

CATHODE CURRENTS—

12S67	8.7 MA.
12SA7	7.1
12SK7	11.5
12SQ7	11.5
35L6/G	51.5
35Z6/G	51.5

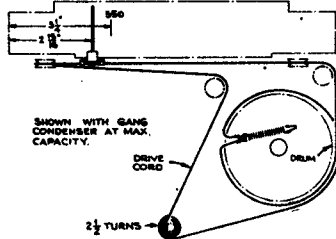

Steps	Connect high side of the test oscillator to—	Tune test osc. to—	Turn radio dial to—	Adjust the following for maximum peak output
1	Pin #4 (signal grid) 12SK7 IF tube in series with 0.1 mfd.			T2† 2nd I-F trans.
2	Pin #8 (signal grid) 12SA7 1st det. in series with 0.1 mfd.	455 kc	Quiet point at 1600 kc end of the dial	T1 1st I-F trans.
3				L2 for minimum output (Wave trap)
4	Antenna in series with 200 mmf.	1300 kc	1300 kc	C22 (osc.) C24 (ant.)
5		600 kc	600 kc	L13 While rocking gang
6	Repeat steps 4 and 5.			
7		9.5 mc.	9.5 mc.	C20 (Osc.)*
8	Antenna in series with 50 mmf.	9.5 mc.	9.5 mc.	C26 Ant. while rocking gang
9				L10 (Osc.)**
10		11.8 mc.	11.8 mc.	L14 while rocking gang
11	Repeat steps 9 and 10.			

*If two peaks are obtained use minimum cap peak.
**If two peaks are obtained use minimum inductance peak.
†Do not repeat step No. 1.

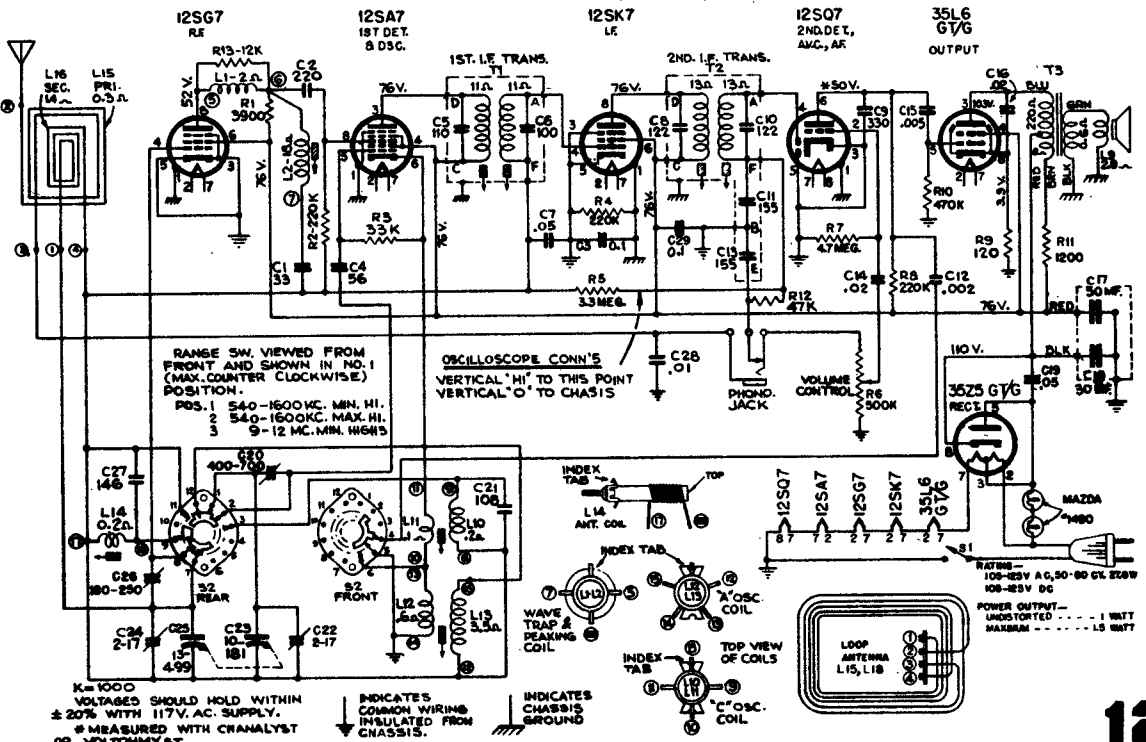

RCA VICTOR

MODEL 66E

Victrola
Chassis No. RS-126

VIBRATION OF LID HOLD

A small piece of spring material is fastened on the inside of the cabinet in such a position as to apply force against the lid hold and keep it from vibrating when the lid is closed.

When servicing the instrument, make certain this spring is in position and serving its purpose.

Removal of Speaker and Jewel Pilot Light

The bottom front and the inside sloped panels are removable, making it convenient for removal of speaker and jewel pilot light.

CRITICAL LEAD DRESS

1. All leads and parts connected to the 6J5 socket should have sufficient slack to insure flexibility of socket.
2. The green lead from the center terminal of R10 volume control to terminal #2 of the 6SQ7 socket should be dressed up and away from all other leads and parts.

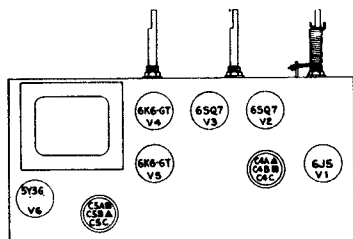

ADJUSTMENT OF VOLUME CONTROL LOCK

This instrument is provided with a Volume Control Lock, which can be adjusted in such a manner that will permit the control to be operated from zero to some pre-determined "Maximum" level to which it has been locked.

1. While instrument is in operation, remove Volume control knob.
2. The ends of two different weight springs can be seen in the Volume control shaft opening in the cabinet.
3. Turn Control "Maximum" clockwise until it is against stop.
4. To INCREASE desired maximum Volume level—
 - (a) Apply just enough force (to unlock volume control shaft) with the eraser end of a pencil, on the end of the light weight spring, in direction indicated in sketch "B"



- (b) Rotate volume control shaft in direction indicated until desired level is reached.
 - (c) Releasing force on spring automatically locks control so it can be operated from zero to the level where it has been locked.
5. To DECREASE desired maximum Volume level—
 - (a) Apply force with the eraser end of a pencil on the heavy weight spring as indicated in sketch (c).



- (b) Rotate to a very low level, then proceed as in step 4.

NOTE: The procedure in step (5b) is necessary to prevent possible error that may be introduced due to backlash.

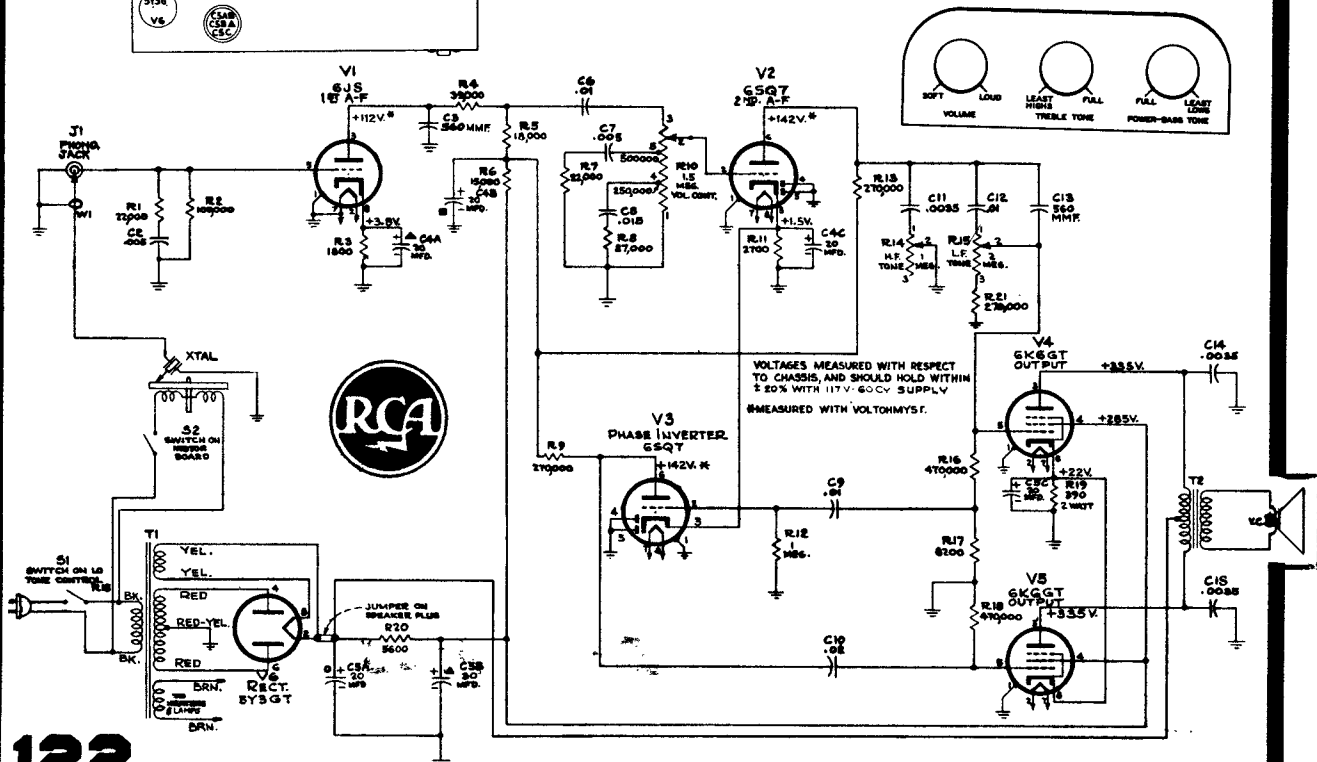

APPROX. GAIN DATA

3X KC 600 - 455 KC 0.7X - 455 KC 220X 455 KC 0.6X - 455 KC 60X 400V 9X 400V

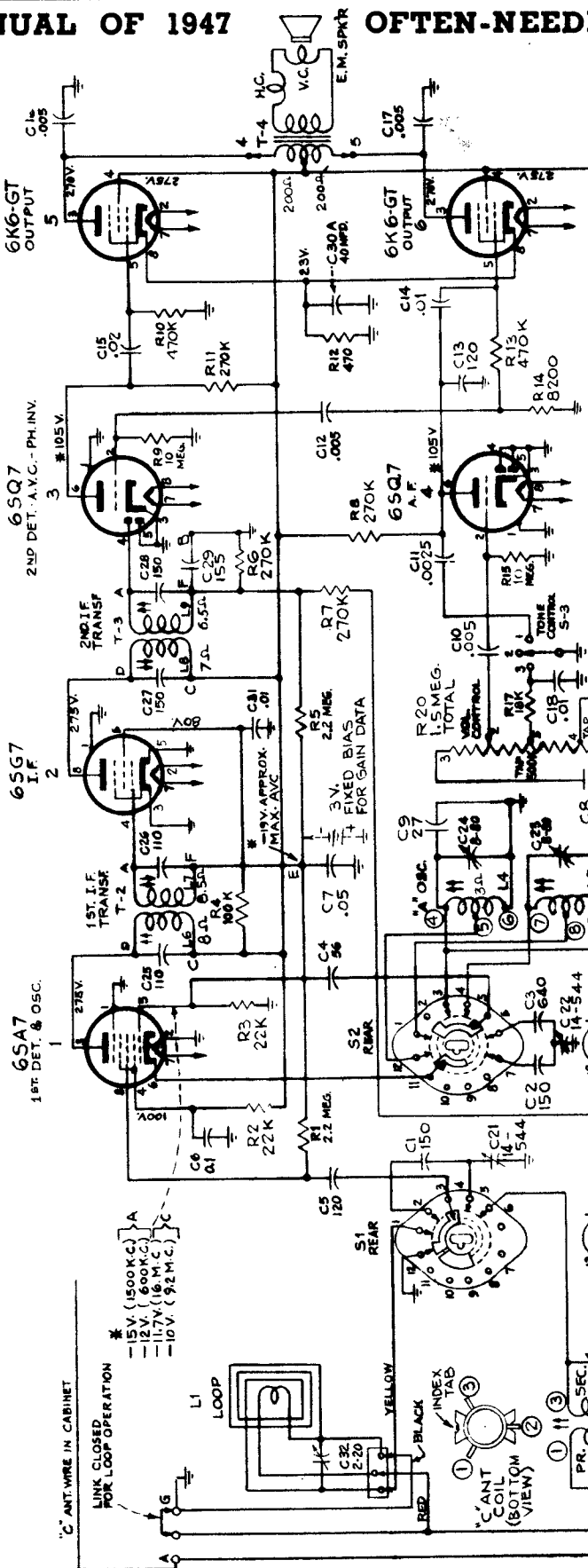

CATHODE CURRENTS

(1) 6SA7	9.8 MA.
(2) 6SQ7	8.8 MA.
(3) 6SQ7	0.7 MA.
(4) 6SQ7	0.7 MA.
(5) 6K6GT	24.5 MA.
(6) 6K6GT	24.5 MA.
(7) 5Y3GT	6.9 MA.

RCA Victor
Models 67V1, 67AV1
Chassis No. RC-606

RANGE SWITCH VIEWED FROM FRONT & SHOWN IN "PHONO" POSITION. (MAX. COUNTERWISE POSITION)

VOLTAGES SHOULD HOLD WITHIN ± 20% WITH 117V. AC. SUPPLY.

* MEASURED WITH CHANALYST OR VOLTOHMYST.

K=1000

RCA VICTOR

VICTROLA 67VI, 67AVI

Radio-Phonograph Combination

Chassis No. RC-606,

FOR AUTOMATIC CHANGER INFORMATION
REFER TO SERVICE DATA FOR MODEL 960260-1

Output Meter Alignment.—If this method is used, connect the meter across the voice coil, and turn the receiver volume control to maximum.

Test Oscillator.—For all alignment operations, connect the low side of the test-oscillator to the receiver chassis, and keep the oscillator output as low as possible to avoid a-v-c action

Calibration Scale.—The dial scale printed in this service note may be temporarily attached to the chassis for quick reference during alignment.

Using Printed Dial Scale.—

1. Cut out the printed dial scale, or, better still, make a tracing of the scale.
2. With gang at full mesh the pointer should be set to the second reference mark from the left hand end of the dial backing plate.
3. Place the printed dial scale or the tracing under the pointer so that the extreme left scale graduations coincide with the pointer. Use scotch tape to hold the dial scale in place.

Note.—It is not recommended that the glass dial scale in the cabinet be removed as an alignment reference. This glass dial scale is fastened to the bezel with sheet metal lugs bent over the scale to hold it in place. Removing the glass dial scale will necessitate bending the lugs, resulting in their weakening and subsequent breakage.

"C" Band Reception.—For best reception on "C" band with an outside antenna, adjust the trimmer-screw of C20 on the antenna coil. Turn screw carefully with an insulated screwdriver (RCA Stock No: 31031) while the receiver is tuned to a station in the 31-meter band. If returning to internal antenna at any time, close the link on the center terminal and readjust "C" band antenna trimmer C20 for best reception on 31-meter band.

For additional information, refer to booklet, "RCA Victor Receiver Alignment."

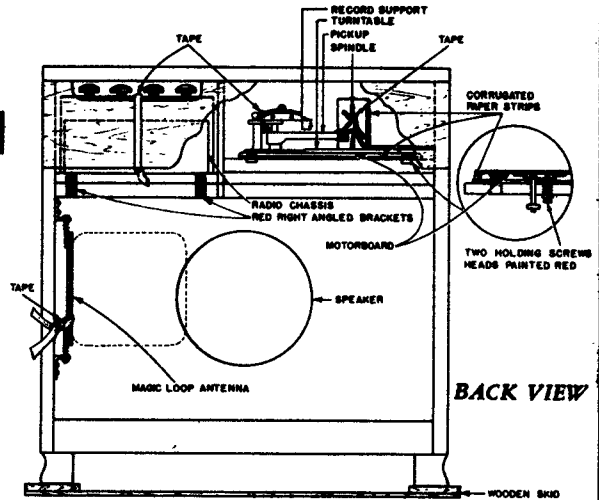

Critical Lead Dress:

1. Dress speaker cable leads down next to chassis.
2. Dress output plate capacitors next to chassis.
3. Dress plate lead of output tube away from grid of audio amplifier.
4. Dress all a-c leads away from volume control down next to chassis.
5. Dress R16 away from a-c leads at on-off switch.
6. Dress R2 away from side of chassis.

Note.—In order to remove the chassis from the cabinet, remove the knobs and the connecting cables, then unscrew the four slotted hex head screws from the two "L" brackets bolted to the rear of the chassis. The chassis may then be slid out toward the bottom rear of the cabinet. Do not remove the hinge screws or the two large nuts in the rear of the chassis. When replacing the chassis, make sure that the tapered pins on the front of the chassis fit into the holes on the metal runners screwed to the cabinet door.

Steps	Connect high side of test oscillator to—	Tune test oscillator to—	Turn radio dial to—	Adjust the following for maximum peak output
1	6SG7 grid in series with .01 mfd.	455 kc.	Broadcast Quiet Point at 550 kc. end of dial	L8, L9 (2nd I-F Trans.)
2	6SA7 grid in series with .01 mfd.	1,400 kc.	Broadcast 1400 kc.	L8, L7 (1st I-F Trans.)
3	Yellow lead on loop in series with 200 mfd. (link closed)	600 kc.	Broadcast 600 kc.	L4 (osc.) Rock gang
4		Repeat steps 3 and 4.		
5	Antenna terminal in series with 47 mmfd.	15.2 mc.	Short Wave 15.2 mc.	C23 (osc.)* C20 (ant.)
6		9.5 mc.	Short Wave 9.5 mc.	L5 (osc.) L9 (ant.)
7		Repeat steps 6 and 7		
8	Install and connect chassis in cabinet with link closed. Tune in a radiated signal of 1400 kc. on broadcast band and peak C22 on loop.			

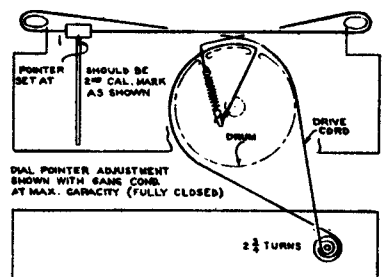
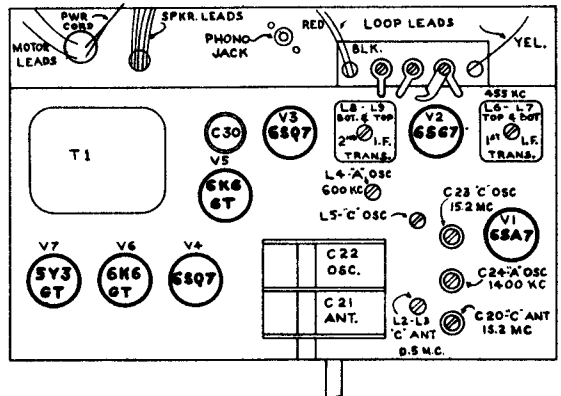

* Use minimum capacity peak if two can be obtained. Check for selection of correct peak by tuning the receiver to approximately 14.3 mc., where a weaker signal should be received.

Oscillator tracks 455 kc. above signal on both bands.

MANUAL OF 1947 MOST-OFTEN-NEEDED RADIO DIAGRAMS

RCA VICTOR 65X1, 65X2

Chassis No. RC-1034

Steps	Connect the high side of test-oscillator to—	Tune test-osc. to—	Turn radio dial to—	Adjust the following for max. peak output
1	12SK7 I-F grid through 0.1 mfd. capacitor	455 kc	Quiet-point 1,600 kc end of dial	C8 and C9 2nd I-F transformer
2	Stator of C2 through 0.1 mfd.			*C6 and C7 1st I-F transformer
3	Ant. lead in series with 200 mmfd.	1,300 kc	1,300 kc	C3 (osc.) C1 (ant.)
4		600 kc	600 kc "A" Band	L5 (osc.) Rock gang
5	Repeat steps 3 and 4			

* Do not readjust C8 or C9 when test oscillator is connected to C2.

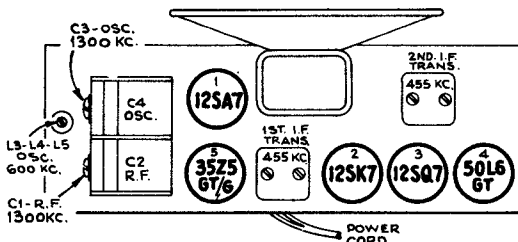

Output Meter Alignment.—If this method is used, connect the meter across the voice coil, and turn the receiver volume control to maximum.

Test-Oscillator.—For all alignment operations, connect the low side of the test-oscillator to the receiver chassis, and keep the oscillator output as low as possible to avoid a-v-c action.

Calibration Scale.—The glass tuning dial may be removed from the cabinet and mounted above the pointer for reference during alignment. The extreme left hand mark of the Standard Broadcast scale must be in line with the left hand mark on the dial backing plate.

Dial Backing Plate.—In the event that only the chassis is returned for service, the marks on the dial backing plate may be used during alignment; refer to the Dial Indicator and Drive Mechanism drawing for corresponding frequencies.

Dial Pointer.—With the gang condenser in full mesh the dial pointer should be set to the left hand reference mark on the dial backing plate.

For additional information refer to booklet "RCA Victor Receiver Alignment."

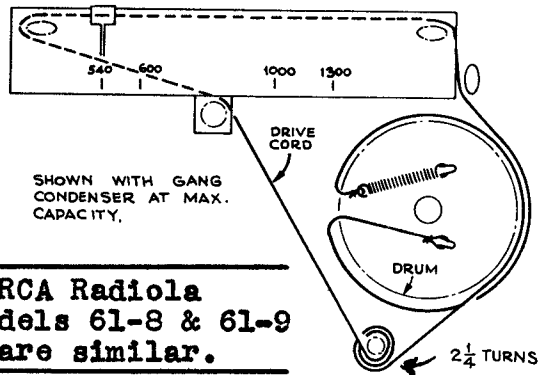

SHOWN WITH GANG CONDENSER AT MAX. CAPACITY.

RCA Radiola
Models 61-8 & 61-9
are similar.

Dial-Indicator and Drive Mechanism

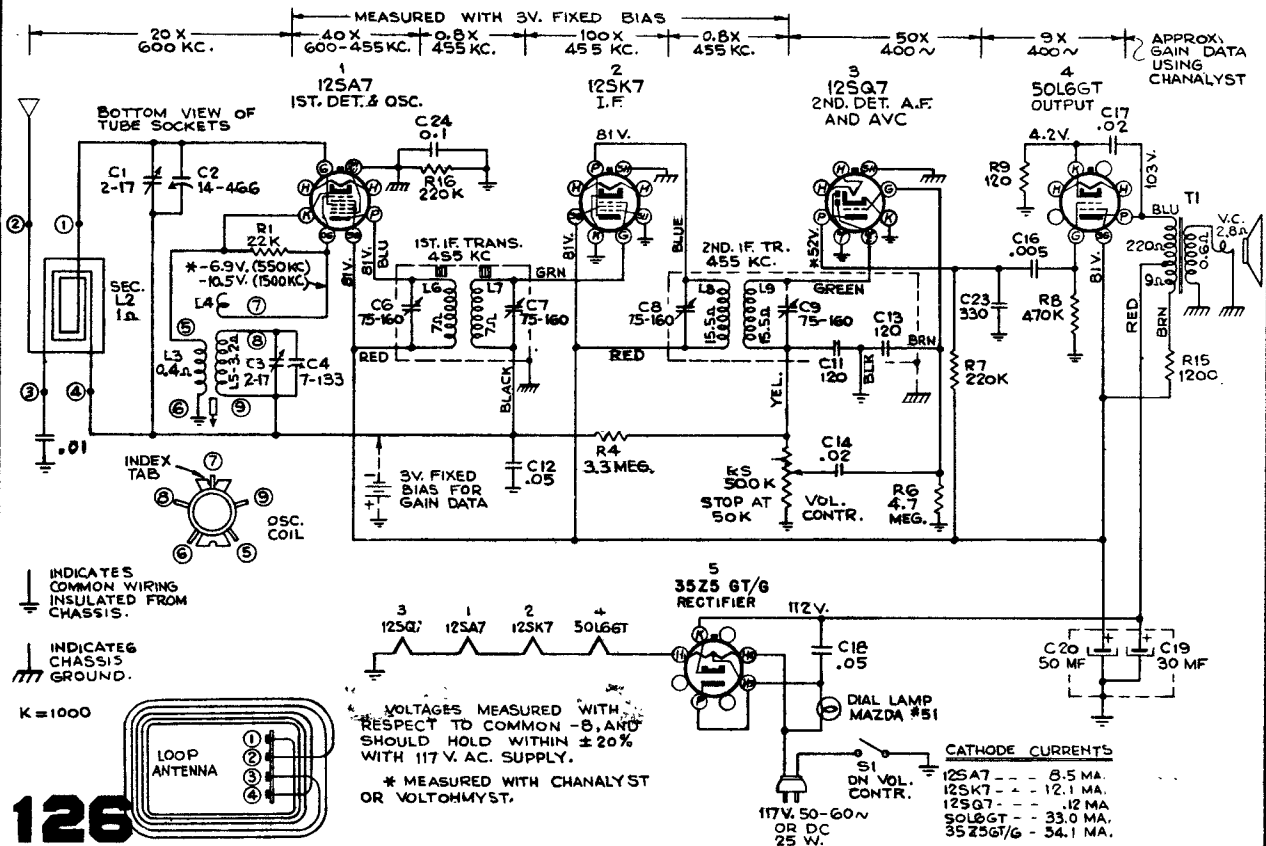

MANUAL OF 1947 MOST-OFTEN-NEEDED RADIO DIAGRAMS

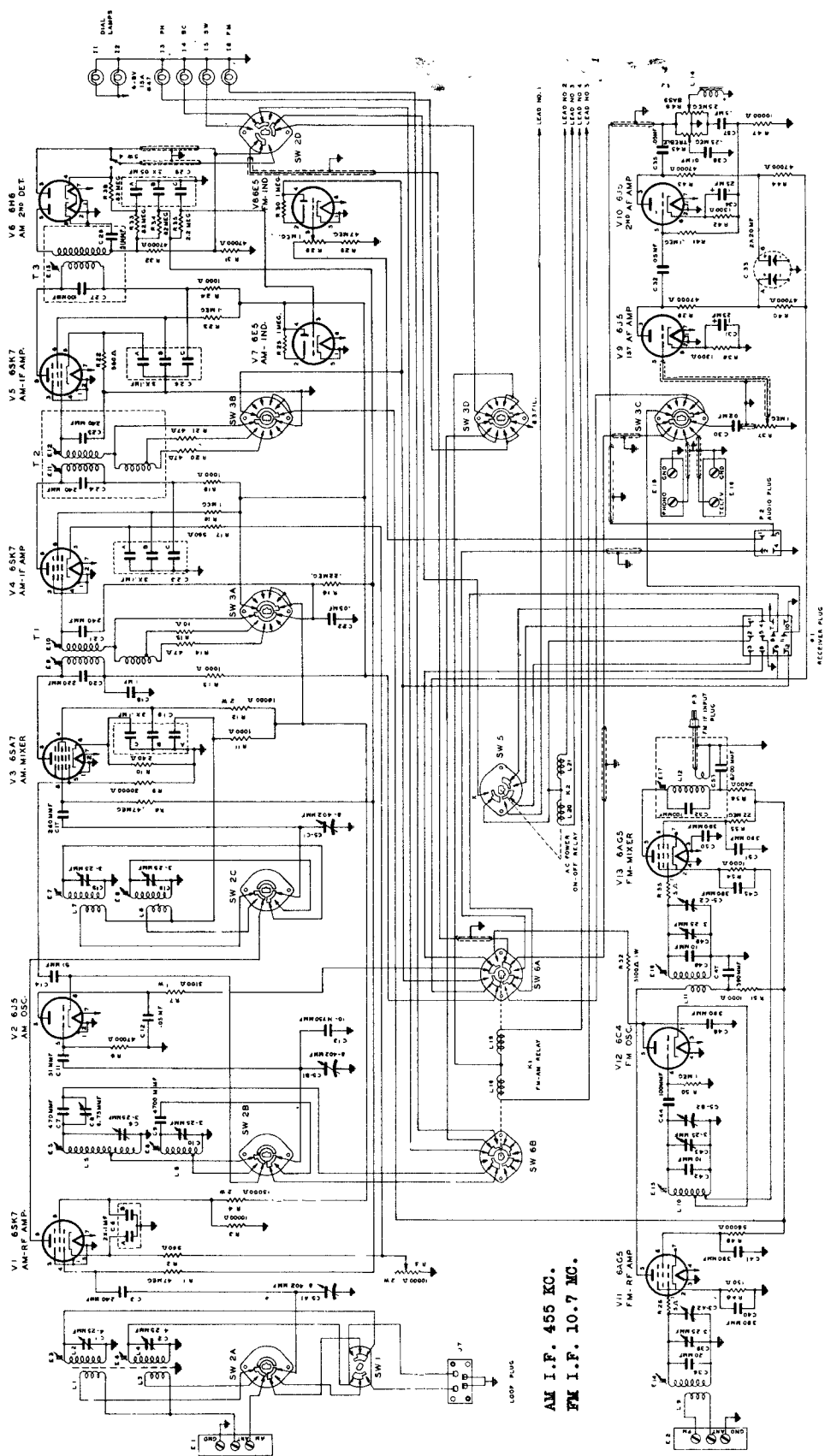

AM I.F. 455 KC.
FM I.F. 10.7 MC.

SCOTT RADIO LABORATORIES INC.
CHICAGO 40 ILLINOIS

Revised Schematic Diagram Model 800-B Receiver Chassis

MANUAL OF 1947 MOST-OFTEN-NEEDED RADIO DIAGRAMS

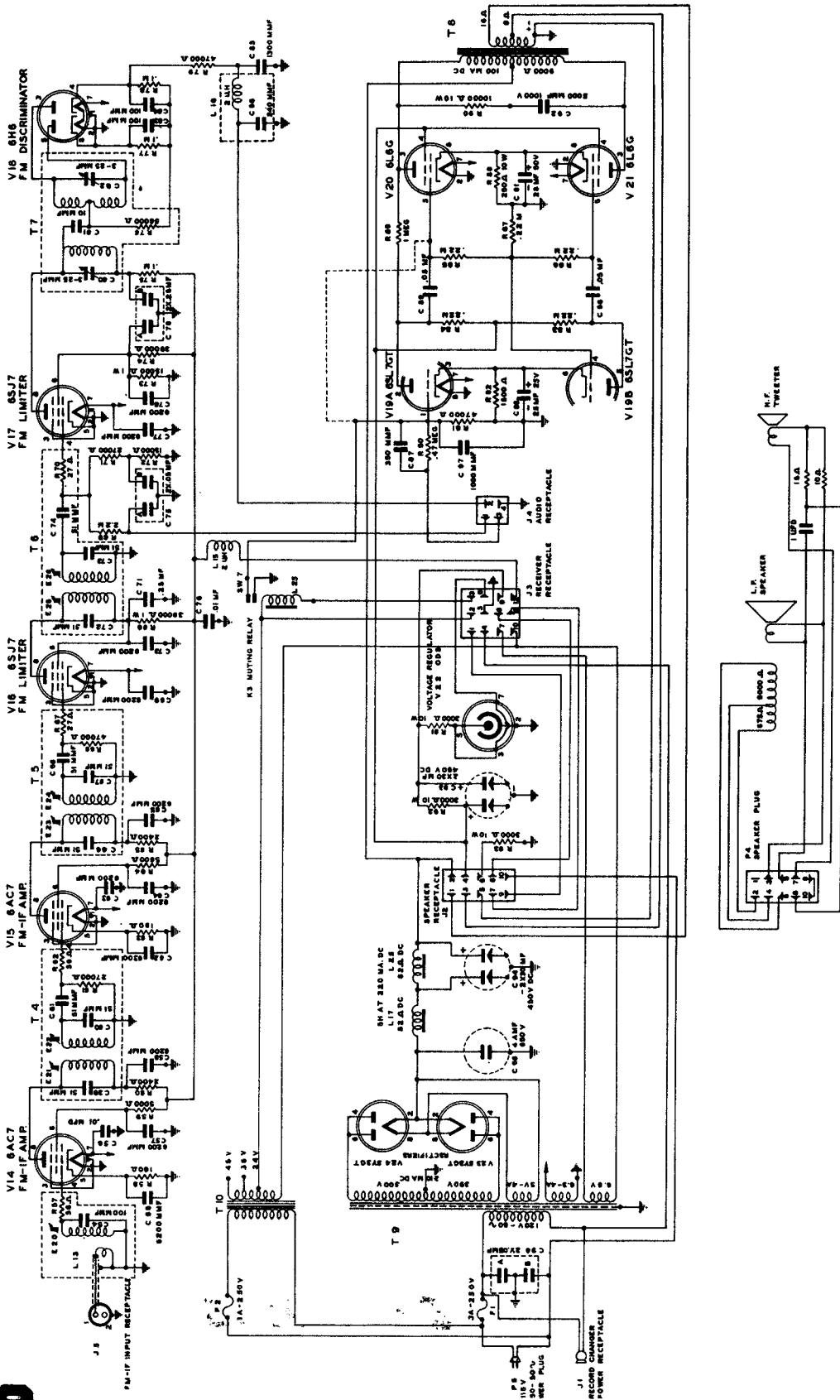

SCOTT RADIO LABORATORIES INC.
CHICAGO 40 ILLINOIS

Revised Schematic Diagram Model 800-B Power Supply

MANUAL OF 1947 MOST-OFTEN-NEEDED RADIO DIAGRAMS

Sears, Roebuck & Co. Models 6050, 132.825-4
 Models 6071, 132.826-1, similar but with phone.

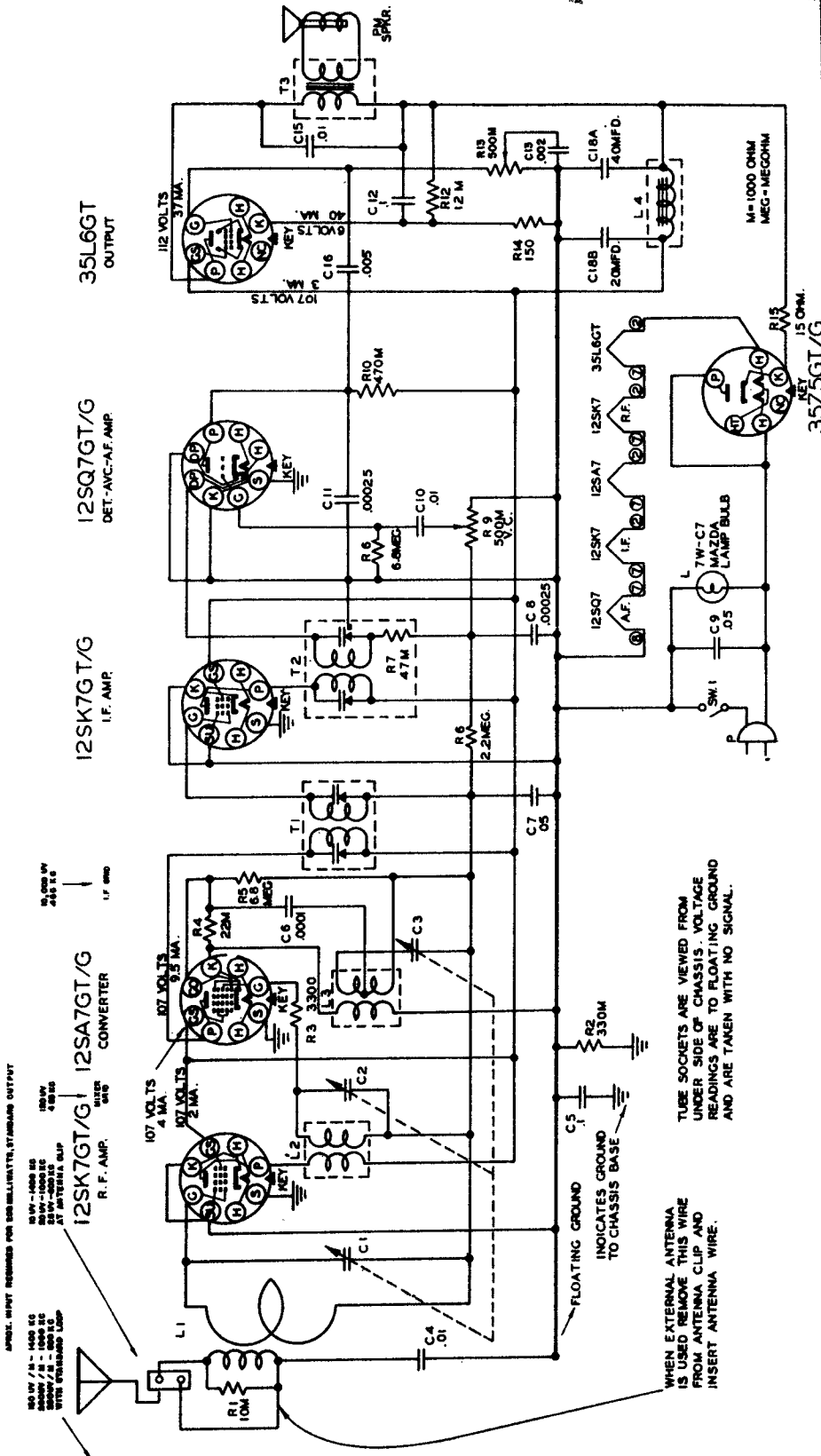

ALIGNMENT DATA

With variable condenser closed set pointer horizontal.

Position of Variable	Generator Frequency	Dummy Ant.	Generator Connection	Generator Connection	Adjust Trimmers (In order shown)	Trimmer Function
Open	455 Kc	.05 mfd	(high)	(low)	T2-T1	I-F
1400	1400	50 mmfd	Mixer grid	Chassis	C3-C2-C1	Osc.-Mixer R-f

NOTE: Trimmer C3 (oscillator) is located either above or below, depending upon the type of variable condenser used in any particular receiver.

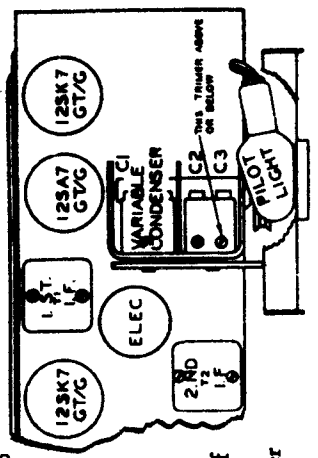

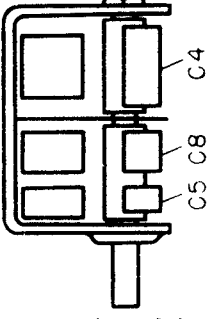
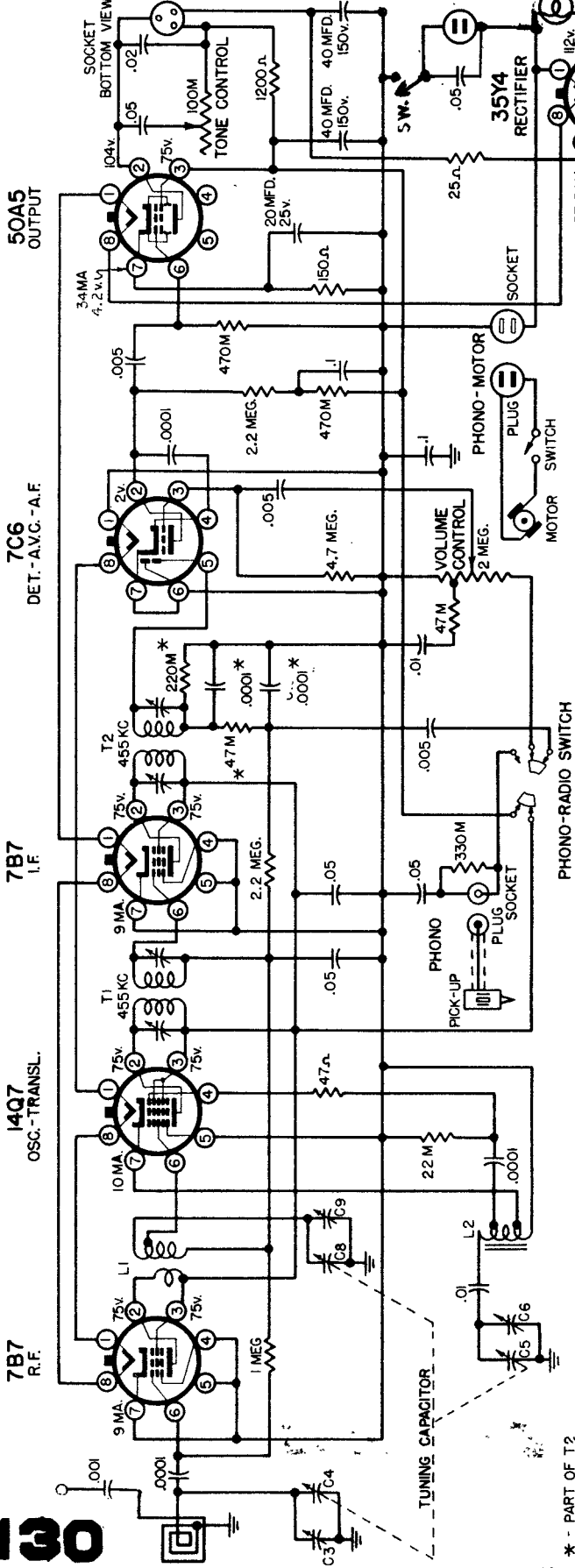

ALIGNMENT PROCEDURE

Output meter connection.....Across loud speaker voice coil
 Generator ground lead connection.....I.F. alignment-negative 'B' lead
 Dummy antenna value: to be in series with generator output.....R.F. alignment-receiver chassis
 Connection of generator output lead.....See chart below
 Generator Modulation.....See chart below
 Position of Volume Control.....30%, 400 cycles
 Position of Tuner.....Fully on
 Position of pointer with tuner fully closed.....Last line below 540 calibration mark

POSITION OF TUNER	GENERATOR FREQUENCY	DUMMY ANTENNA	GENERATOR CONNECTION	TRIMMERS (ADJ. IN ORDER SHOWN)
Closed	455 Kc.	0.1 mfd.	Transl.-Gr id	T2 - T1
1500 Kc.	1500 Kc.	200 mmfd.	Ant.	C5
1500 Kc.	1500 Kc.	200 mmfd.	Ant.	C8
1500 Kc.	1500 Kc.	200 mmfd.	Ant.	C4

Sears, Roebuck & Co.
 Models 7080, 7100, 101.811,
 Phono & Switch omitted on
 Models 7054, 101.808,
 and 7090, 101.810.

TUBE SOCKETS ARE VIEWED FROM UNDER SIDE OF CHASSIS. VOLTAGE READINGS SHOWN AT SOCKET PRONGS ARE TO NEG. 'B', AND ARE TAKEN WITH NO SIGNAL, WITH PHONO-RADIO SWITCH IN RADIO POSITION, AND WITH LINE VOLTAGE AT 117 VOLTS. WHERE NO READING IS GIVEN THE VOLTAGE IS ZERO OR TOO LOW TO READ.

MANUAL OF 1947 MOST-OFTEN-NEEDED RADIO DIAGRAMS

Sears, Roebuck & Co. Models 7115, 7116, 7117, 101.825

Preliminary APPROXIMATE F.M. I.F. ALIGNMENT

Indicating meter connection.....DC voltmeter connected across R24
 Generator ground lead connection.....Chassis
 Generator output lead connection.....See Chart Below
 Generator modulation.....Off
 Position of volume control.....Fully on
 Position of tone control.....Treble (fully clockwise)
 Position of pointer with tuner fully closed.....Last line below 88 Mc.

Wave Band Switch Position	Position of Tuner	Generator Frequency	Dummy Antenna	Generator Connection	Trimmer Adjustments (in order shown)	Trimmer Function
F.M. (Counter- clockwise)	Closed	10.7 Mc.	0.1 mfd.	Transl. Grid	C41, C40, C32 C29, C25, C22	I.F.

Adjust for a maximum reading on DC voltmeter. As trimmers are adjusted, decrease the output of the generator to maintain approximately 2 volts.

FINAL A.M. ALIGNMENT

Output meter connection.....Across loudspeaker voice coil
 Generator ground lead connection.....Chassis
 Dummy antenna value to be in series with generator output.....See Chart
 Connection of generator output lead.....See Chart
 Generator modulation.....30%, 400 cycles
 Position of volume control.....Fully on
 Position of tone control.....Treble (Fully clockwise)
 Position of pointer with tuner fully closed.....Last line below 540 calibration mark
 AM ant. selector switch in "up" position.....

Wave Band Switch Position	Position of Tuner	Generator Frequency	Dummy Antenna	Generator Connection	Trimmer Adjustments (in order shown)	Trimmer Function
BC (center)	Closed	455 Kc.	0.1 mfd.	Transl. Grid	C33, C30, C26, C23	I.F.
BC	1500 Kc.	1500 Kc.	200 mmfd.	Ant.	C13	Osc.
BC	1500 Kc.	1500 Kc.	200 mmfd.	Ant.	C11	R.F.

Continued on the next page

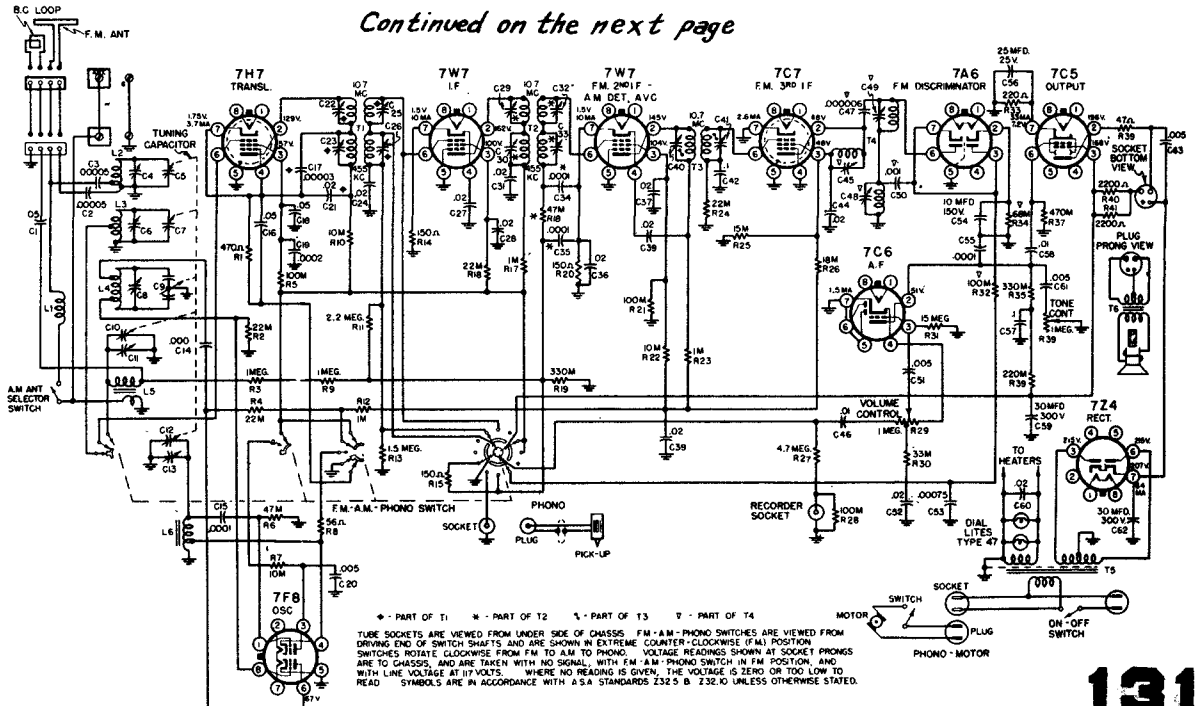

MANUAL OF 1947 MOST-OFTEN-NEEDED RADIO DIAGRAMS

Sears, Roebuck & Co. Models 7115, 7116, 7117, 101.825

FINAL F.M. ALIGNMENT

- A. If a 10.7 Mc. frequency modulated generator is available, connect to translator grid through e 270 to 500 ohm resistor and proceed to Section C.
- B. If no 10.7 Mc. frequency modulated generator is available, connect an R.F. - F.M. generator to the F.M. antenna terminals.
- C. Connect 5000 ohms (if generator sweep frequency is 60 cycles) to ground in parallel with R24. For lower frequency sweep increase the 5000 ohm resistor proportionately. Connect the Y-axis (vertical) amplifier of an oscilloscope across R24 to ground. Put a 10,000 to 100,000 ohm resistor in series with oscilloscope lead (at receiver end) to provide R.F. filterings.
- D. Connect the sweep output of the generator to the X-axis (horizontal) amplifier of the oscilloscope.
- E. Adjust modulation for a 300 Kc. deviation and touch up alignment of C41, C40, C32, C29, C25 and C22 for a symmetrical pattern on oscilloscope. Use full gain of the oscilloscope Y-axis amplifier and only as much output from the generator as is necessary. See FIG. 1A, (PAGE 11) for approximate pattern.
- F. Remove the oscilloscope and the two resistors that were added in Section C above. (Restore receiver to normal operating condition).
- G. Connect the Y-axis (vertical) amplifier of the oscilloscope to the ungrounded side of C53 through 10,000 to 100,000 ohms at receiver end of lead.
- H. Adjust C45 for maximum output, vertically. Adjust C48 and C49 until the center of the pattern becomes a straight line diagonally across the oscilloscope screen. Re-peak these three trimmers to obtain a symmetrical pattern of maximum vertical amplitude. See oscilloscope pattern, FIG. 1B, (PAGE 11).
- I. Remove the generator. Remove the oscilloscope and resistor from C53, and replace across R24 as described in Section C above.
- J. Connect an R.F. F.M. generator to the terminals marked F.M. antenna through two 120-ohm resistors, one in series with each terminal of the generator. Adjust the generator for 300 Kc. deviation.
- K. Tune the generator to 109 Mc. Set pointer to 109 Mc. Adjust C8 to obtain 3rd. I.F. oscilloscope pattern. See FIG 1A (PAGE 11). (If two such points are found by tuning C8, use the higher frequency.) (Lowest capacity setting of C8).
- L. Tune the generator and receiver to 106 mc. and peak C6 and C4 for maximum vertical amplitude on the oscilloscope. (See FIG. 1A below).
- M. Remove the signal generator, oscilloscope and resistors, restoring the receiver to normal operating condition.

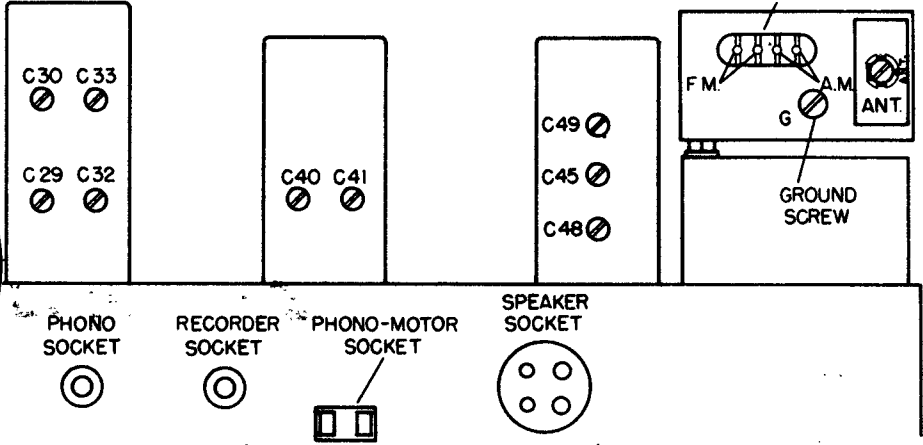
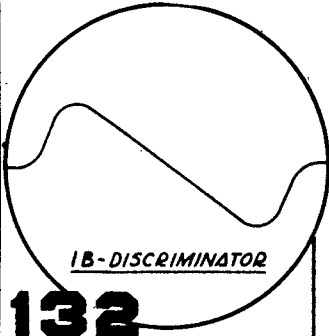
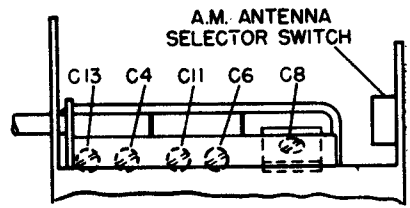
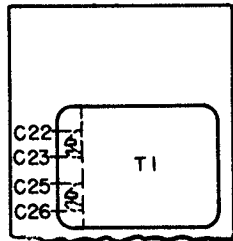
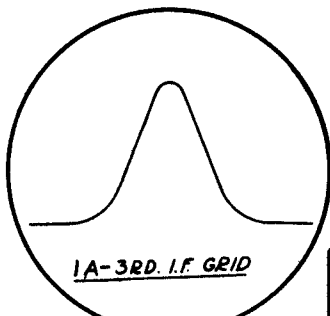

MANUAL OF 1947 MOST-OFTEN-NEEDED RADIO DIAGRAMS

SEARS, ROEBUCK AND CO.

Models 6011, 6012, 132.816, 132.816A.

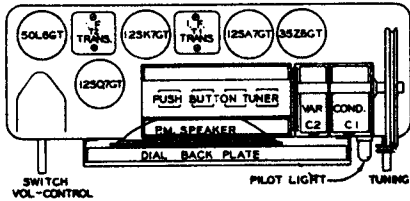

Tuning range 540 Kc to 1600 Kc. Intermediate frequency—455 Kc. RF and IF measurements made at 50 milliwatts output—approximately .38 volt on a rectifier type voltmeter connected across the voice coil.

Approximate inputs for 50 MW output: IF—75 uv. RF with standard loop: at 600 Kc—400 uv/m; at 1000 Kc—350 uv/m; at 1400 Kc—350 uv/m. RF at antenna clip: at 600 Kc—50 uv; at 1000 Kc—40 uv; at 1400 Kc—40 uv.

ALIGNMENT DATA

Position of Variable	Generator Frequency	Dummy Ant.	Generator Connection (high side)	Generator Connection (low side)	Adjust Trimmers (In order shown)	Trimmer Function
Open	455 Kc	.05 mfd.	Mixer grid	Float. Gnd.	T2-T1	IF
Open	1620 Kc	50 mmfd.	Ant. clip	Chassis	C2	Osc.
1400	1400 Kc	50 mmfd.	Ant. clip	Chassis	C1	Ant.

TO RESET POINTER: With the receiver tuned to a 1400 Kc signal, attach pointer to dial cord so as to align with inverted "V" notch on lower ledge of dial backing plate.

This radio receiver is equipped with a built-in antenna which will be satisfactory for local reception. If you are located some distance from a station, or local noise from electrical equipment is bothersome, reception will be greatly improved by the installation of an outside antenna. Provision is made for connection of an external antenna at the rear of the chassis. Figure 2 indicates the location of the clip to which connection should be made. Be sure to remove the black wire from the clip before attaching the external antenna.

This receiver is designed to operate without a ground connection and no attempt should be made to use one.

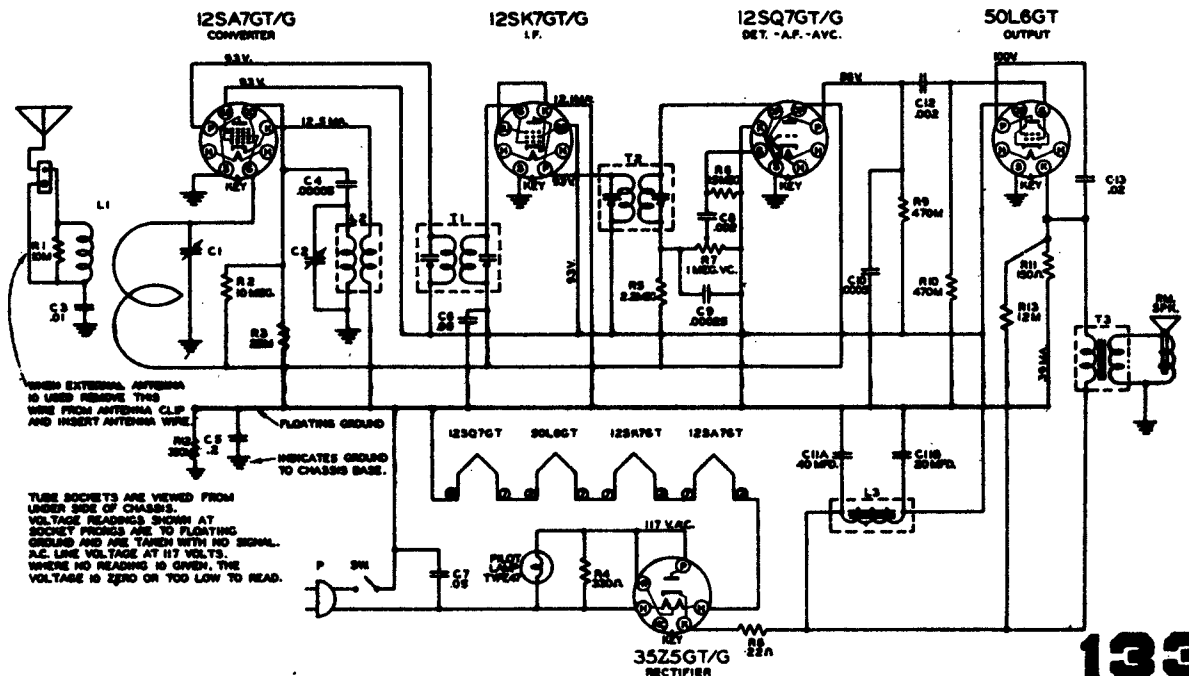
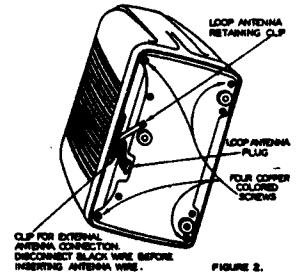

MANUAL OF 1947 MOST-OFTEN-NEEDED RADIO DIAGRAMS

Sonora

Clear as a Bell

Models

RG1MF/RGMFU (212 & 230)

LOOP

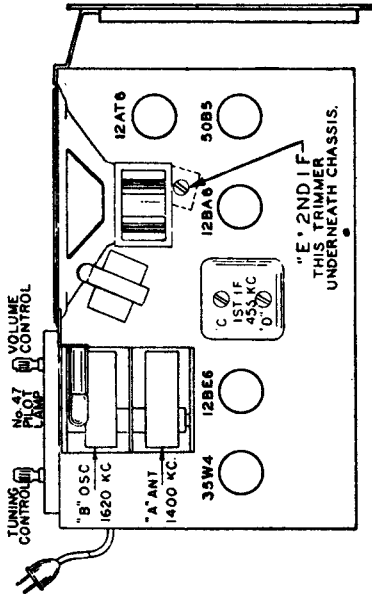
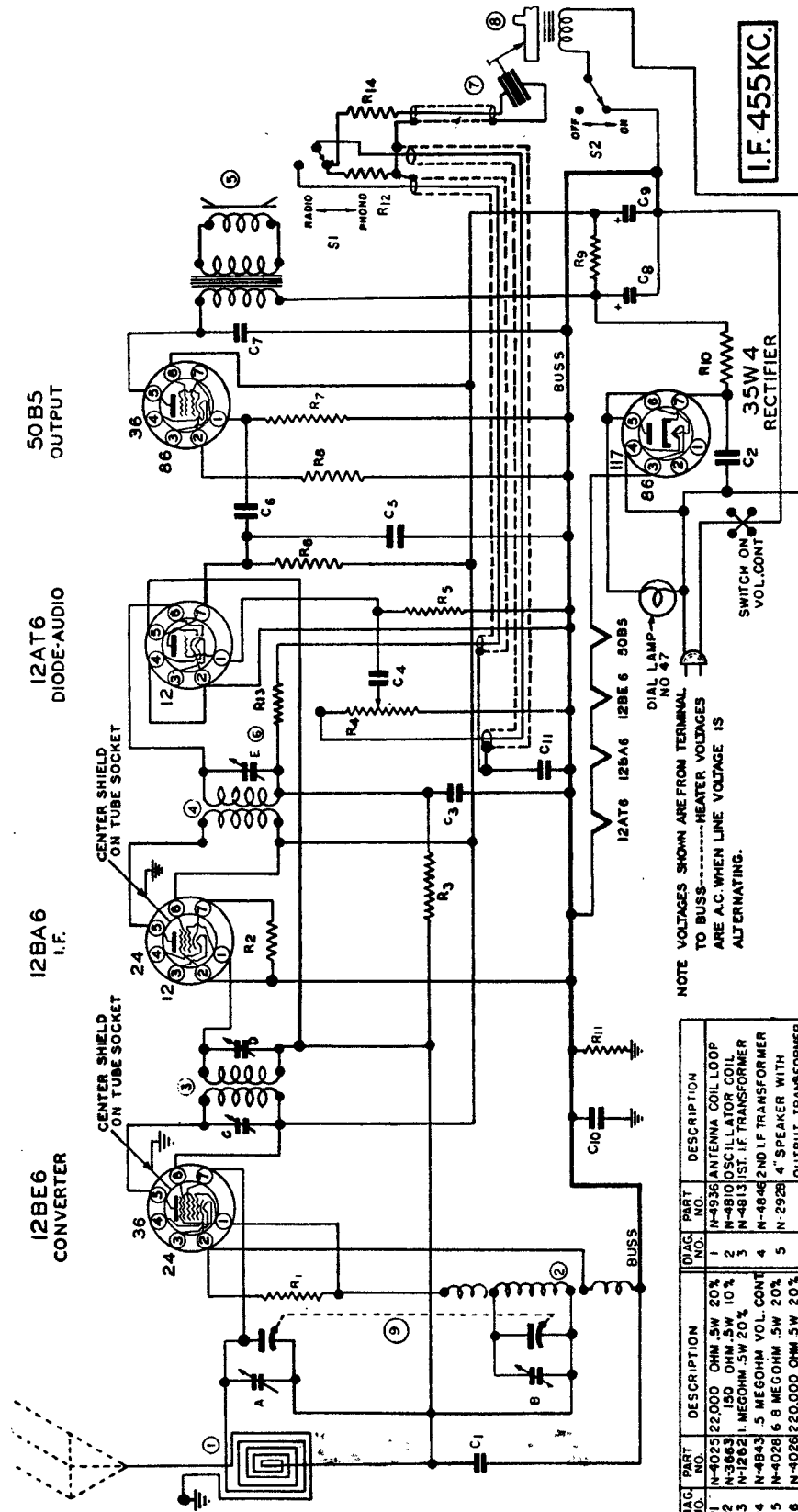

DIAG. PART NO.	PART NO.	DESCRIPTION
R1	N-4025	22,000 OHM .5W 20%
R2	N-3663	150 OHM .5W 10%
R3	N-1262	1 MEG OHM .5W 20%
R4	N-4843	.5 MEG OHM VOL. CONT
R5	N-4028	6.8 MEG OHM .5W 20%
R6	N-4026	220,000 OHM .5W 20%
R7	N-4027	470,000 OHM .5W 20%
R8	N-4024	220 OHM .5W 10% INHUL
R9	N-5359	1000 OHM 1/4 W 10% INHUL
R10	N-5403	33 OHM .5W 20% INHUL
R11	N-4026	220,000 OHM .5W 20%
R12	N-4988	220,000 OHM .5W 20% INHUL
R13	N-4067	47,000 OHM .5W 20% INHUL
R14	N-5405	470,000 OHM .5W 20% INHUL
C1	N-1345	.05 MFD 200V
C2	N-1346	.05 MFD 400V
C3	N-1374	.0001 MFD 500V
C4	N-4894	.005 MFD 600V
C5	N-2306	.0002 MFD 500V
C6	N-1344	.01 MFD 400V
C7	N-1376	.02 MFD 400V
C8	N-4986	40 MFD 150V ELECT.
C9	N-1345	.05 MFD 150V ELECT.
C10	N-1345	.05 MFD 200V
C11	N-1345	.05 MFD 200V

NOTE: VOLTAGES SHOWN ARE FROM TERMINAL TO BUSS—HEATER VOLTAGES ARE AC WHEN LINE VOLTAGE IS ALTERNATING.

MANUAL OF 1947 MOST-OFTEN-NEEDED RADIO DIAGRAMS

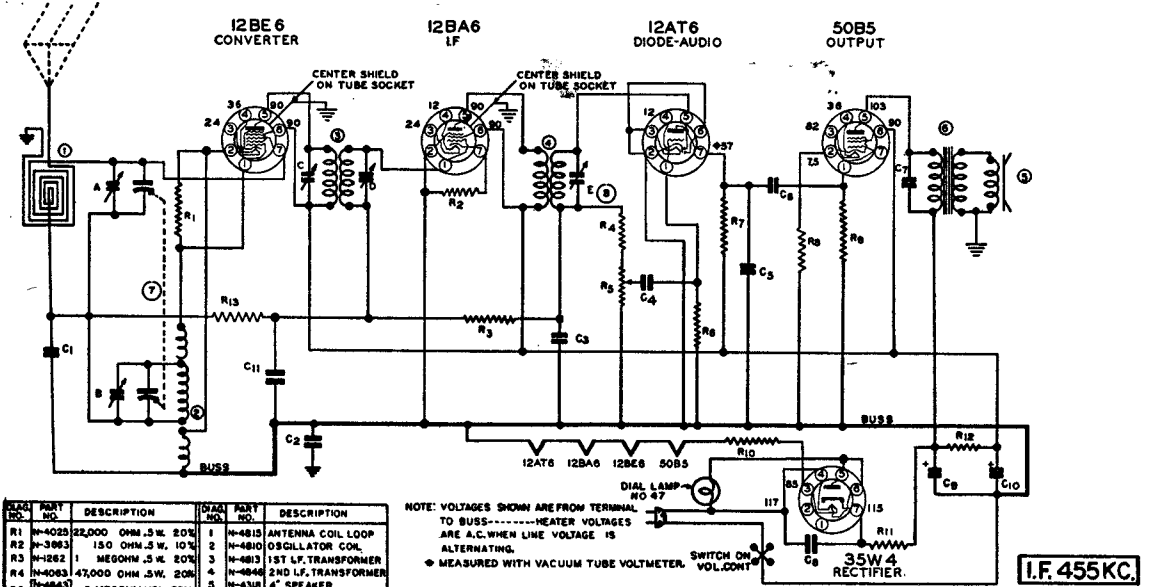

DIAG. NO.	PART NO.	DESCRIPTION	DIAG. NO.	PART NO.	DESCRIPTION
R1	N-4023	22,000 OHM .5 W. 20%	1	N-4815	ANTENNA COIL LOOP
R2	N-3831	150 OHM .5 W. 10%	2	N-4810	OSCILLATOR COIL
R3	N-1282	1 MEGOHM .5 W. 20%	3	N-4813	1ST I.F. TRANSFORMER
R4	N-4063	47,000 OHM .5 W. 20%	4	N-4848	2ND I.F. TRANSFORMER
R5	N-4843	.5 MEGOHM VOL. CONT.	5	N-4318	4" SPEAKER
R6	N-4028	6.8 MEGOHM .5 W. 20%	6	N-3899	OUTPUT TRANSFORMER
R7	N-5532	220 OHM .5 W. 10%	7	N-4046	2 GANG CONDENSER
R8	N-4027	220 OHM .5 W. 20%	8		
R9	N-4027	470,000 OHM .5 W. 20%	9		
R10	N-3831	22 OHM L.W. 10%	10		
R11	N-4022	33 OHM .5 W. 20%	11		
R12	N-5338	1000 OHM L.W. 10%	12		
R13	N-4027	470,000 OHM .5 W. 20%	13		
C1	N-1345	.05 MFD. 200 V.			
C2	N-1345	.05 MFD. 200 V.			
C3	N-1374	100 MFD. MICA			
C4	N-4864	.005 MFD. 400 V.			
C5	N-4890	.0005 MFD. 400 V.			
C6	N-1344	.01 MFD. 400 V.			
C7	N-1378	.02 MFD. 400 V.			
C8	N-1346	.05 MFD. 400 V.			
C9	N-3302	.35 MFD. 150 V. ELECT.			
C10	N-1346	.05 MFD. 400 V.			

NOTE: VOLTAGES SHOWN ARE FROM TERMINAL TO BUSS-----HEATER VOLTAGES ARE A.C. WHEN LINE VOLTAGE IS ALTERNATING.
 * MEASURED WITH VACUUM TUBE VOLTMETER. SWITCH ON VOL. CONT.

I.F. 455 KC.

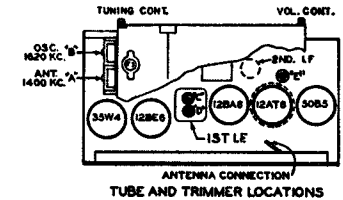

Sonora Radio & Television
 Models REM/REMU

RBMU

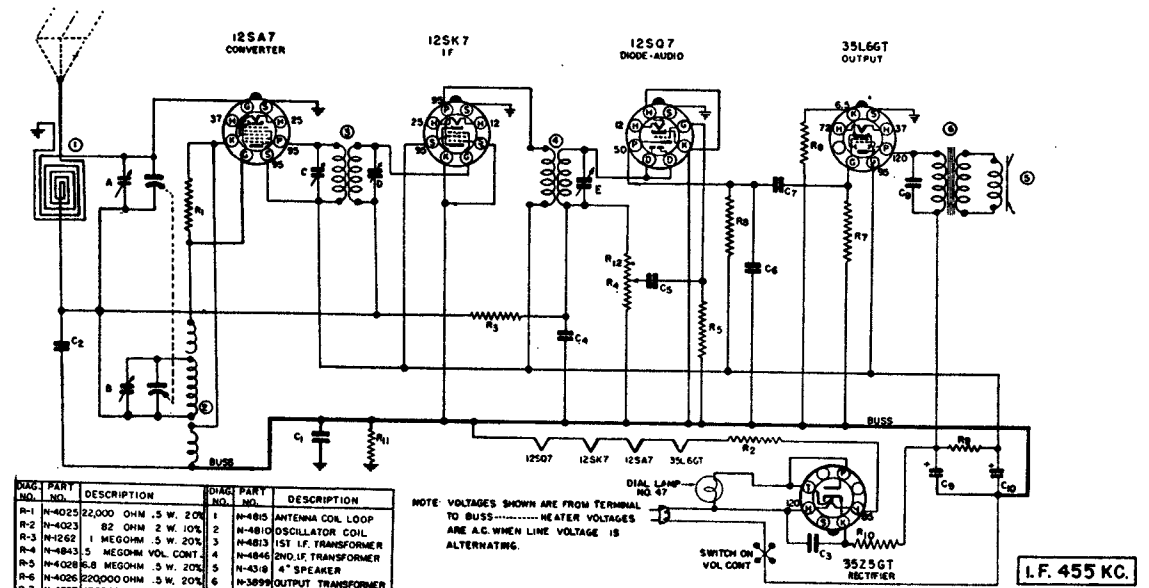

DIAG. NO.	PART NO.	DESCRIPTION	DIAG. NO.	PART NO.	DESCRIPTION
R1	N-4023	22,000 OHM .5 W. 20%	1	N-4815	ANTENNA COIL LOOP
R2	N-4023	82 OHM 2 W. 10%	2	N-4810	OSCILLATOR COIL
R3	N-1282	1 MEGOHM .5 W. 20%	3	N-4813	1ST I.F. TRANSFORMER
R4	N-4843	.5 MEGOHM VOL. CONT.	4	N-4848	2ND I.F. TRANSFORMER
R5	N-4028	6.8 MEGOHM .5 W. 20%	5	N-4318	4" SPEAKER
R6	N-4026	220,000 OHM .5 W. 20%	6	N-3899	OUTPUT TRANSFORMER
R7	N-4027	470,000 OHM .5 W. 20%			
R8	N-4021	220 OHM .5 W. 10%			
R9	N-3341	1000 OHM .5 W. 10%			
R10	N-4022	33 OHM .5 W. 20%			
R11	N-4026	220,000 OHM .5 W. 20%			
R12		(IN VOLUME CONTROL)			
C1	N-1345	.05 MFD. 200 V.			
C2	N-1345	.05 MFD. 200 V.			
C3	N-1346	.05 MFD. 400 V.			
C4	N-4874	100 MFD. MICA			
C5	N-2712	.004 MFD. 400 V.			
C6	N-4447	.0005 MFD. 400 V.			
C7	N-1344	.01 MFD. 400 V.			
C8	N-1378	.02 MFD. 400 V.			
C9	N-3302	.35 MFD. 150 V. ELECT.			
C10					

NOTE: VOLTAGES SHOWN ARE FROM TERMINAL TO BUSS-----HEATER VOLTAGES ARE A.C. WHEN LINE VOLTAGE IS ALTERNATING.
 * MEASURED WITH VACUUM TUBE VOLTMETER. SWITCH ON VOL. CONT.

I.F. 455 KC.

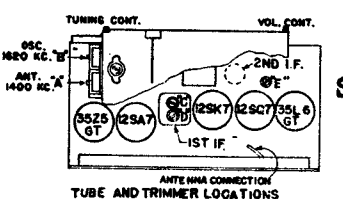

Sonora Radio & Television
 Model REU

MANUAL OF 1947 MOST-OFTEN-NEEDED RADIO DIAGRAMS

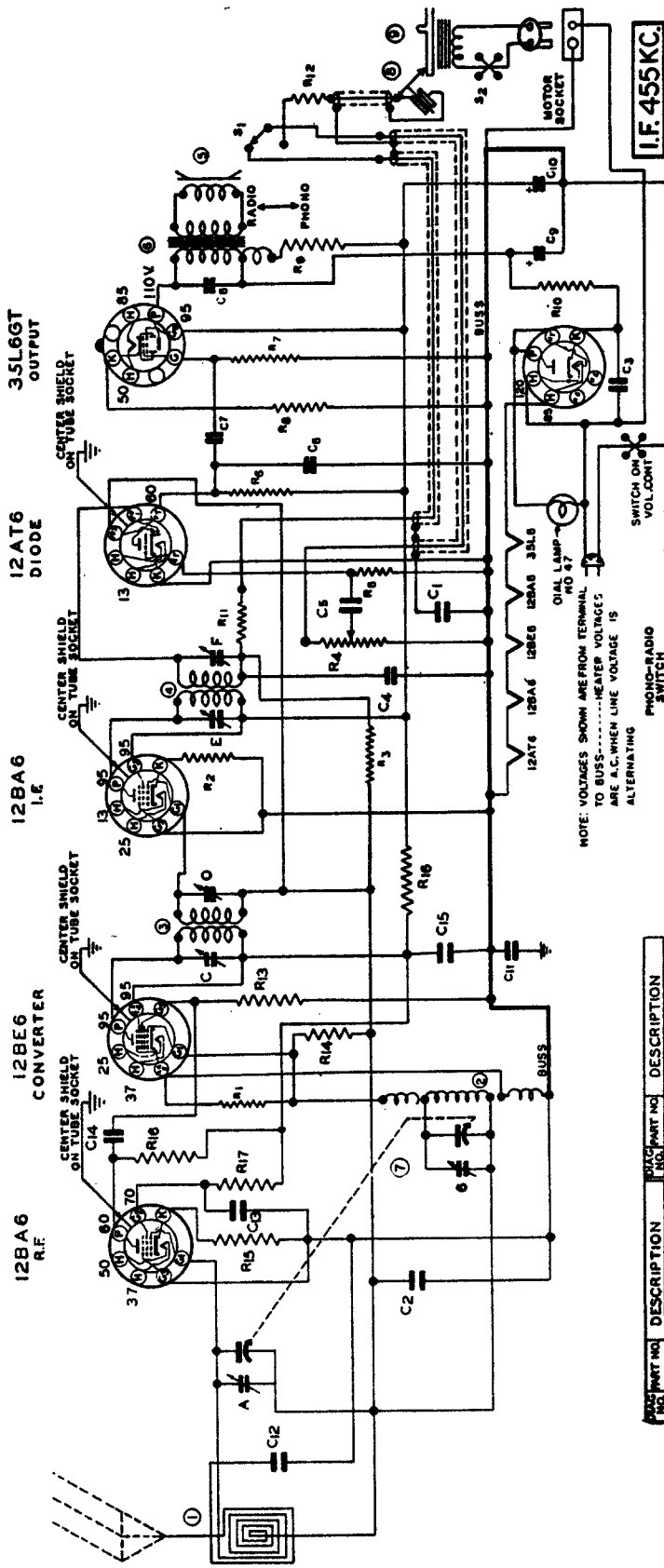

Models
RKR/RKRU (215)

PART NO.	DESCRIPTION	QTY.	PART NO.	DESCRIPTION
R1	22,000 OHM 3 W 20%	1	C7	.01 MFD 400V
R2	150 OHM 3 W 10%	1	C8	.02 MFD 400V
R3	33 MEG OHM 3 W 10%	1	C9	40 MFD 150V ELECT.
R4	5 MEG OHM 3 W 20%	1	C10	40 MFD 150V ELECT.
R5	68 MEG OHM 3 W 20%	1	C11	2 MFD 200V
R6	220,000 OHM 3 W 20%	1	C12	.01 MFD 400V
R7	470,000 OHM 3 W 20%	1	C13	.05 MFD 200V
R8	100 OHM 3 W 10%	1	C14	.00015 MFD MICA
R9	1000 OHM 1 W 10%	1	C15	.1 MFD 200V
R10	33 OHM 3 W 20%	1		
R11	47,000 OHM 3 W 20%	1		
R12	1 MEG OHM 3 W 20%	1		
R13	47,000 OHM 3 W 20%	1		
R14	100 MEG OHM 3 W 20%	1		
R15	150 OHM 3 W 10%	1		
R16	4700 OHM 3 W 10%	1		
R17	22,000 OHM 3 W 20%	1		
R18	220 OHM 3 W 20%	1		
C1	.00 MFD 200V	1		
C2	.05 MFD 200V	1		
C3	.03 MFD 100V	1		
C4	.0001 MFD MICA	1		
C5	.0003 MFD	1		
C6	.0003 MFD	1		

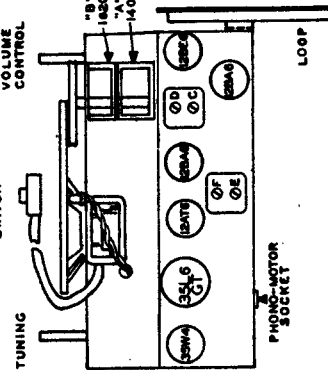

MANUAL OF 1947 MOST-OFTEN-NEEDED RADIO DIAGRAMS

Sonora

Clear as a Bell

Models
RQ/RQU (222)

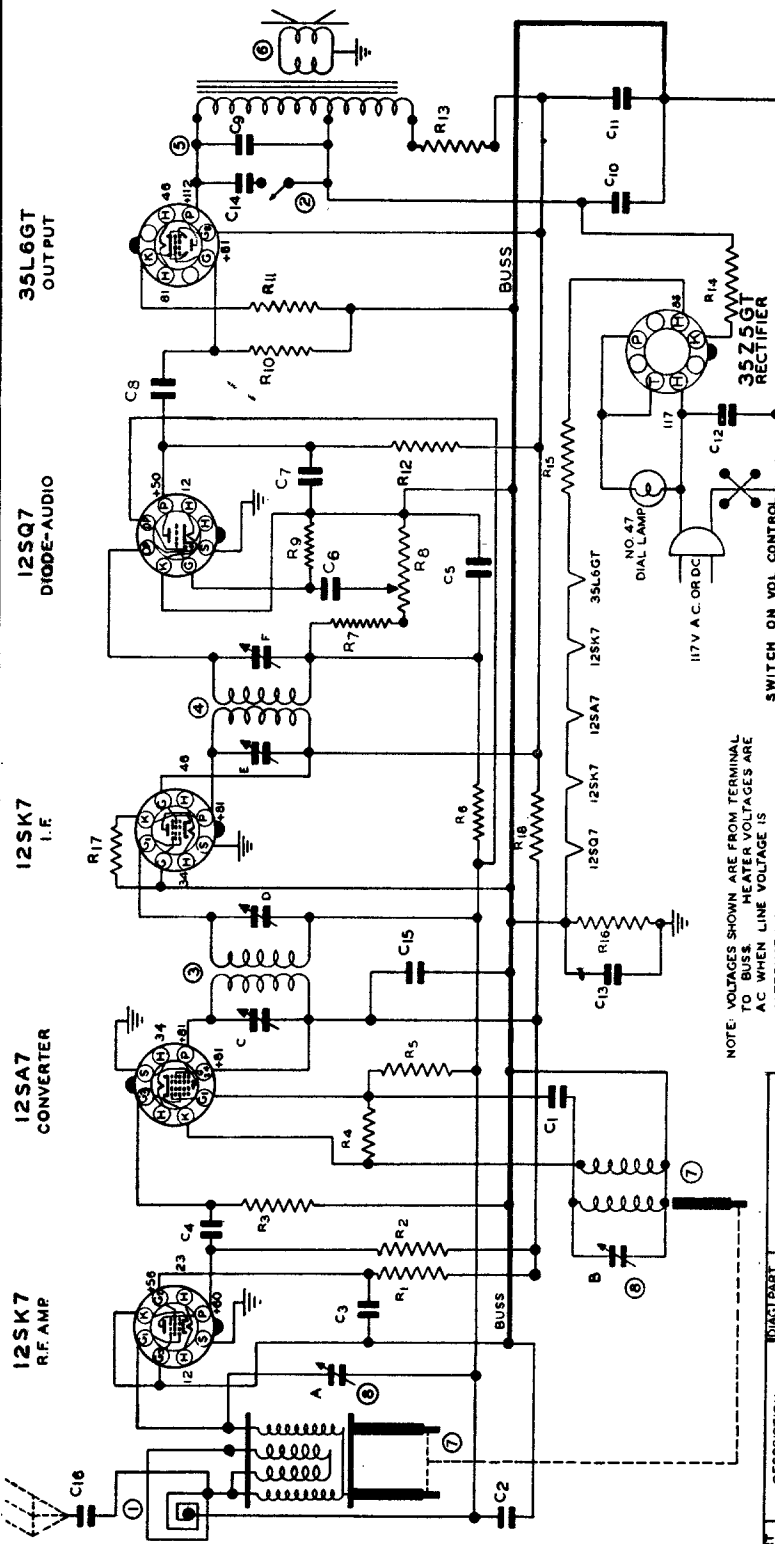

I.F. 455 K.C.

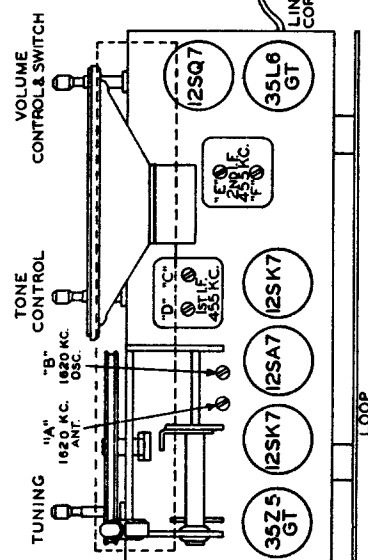

TUBE & TRIMMER LOCATIONS

NOTE: VOLTAGES SHOWN ARE FROM TERMINAL TO B.U.S.S. WHEN LINE VOLTAGE IS ALTERNATING.

COMP. PART NO.	DESCRIPTION	COMP. PART NO.	DESCRIPTION
C1 N-1342	50 MMFD MICA	N-4082	3.3 MEGOHM .5W 20%
C2 N-1345	.05 MFD 200V	N-4083	47,000 OHM .5W 20%
C3 N-1345	.05 MFD 200V	N-5026	0.5 MEGOHM VOL. CONT.
C4 N-2283	150 MMFD MICA	N-4081	47 MEGOHM .5W 20%
C5 N-1374	100 MMFD MICA	N-4027	47,000 OHM .5W 20%
C6 N-4894	.005 MFD 600V -15x40x4	N-4067	180 OHM .5W 10%
C7 N-4890	.0005 MFD 600V -25x60x8	N-4888	220,000 OHM .5W INS. 20%
C8 N-1344	.01 MFD 400V	N-5823	1500 OHM 1W 10%
C9 N-1344	.01 MFD 400V	N-4022	33 OHM .5W 20%
C10 N-3658	40 MMFD 150WV ELECTRO	N-4629	33 OHM 1W 10%
C11 N-3658	40 MMFD 150WV LYTIC	N-4028	220,000 OHM .5W 20%
C12 N-1346	.05 MFD 400V	N-4022	33 OHM .5W 20%
C13 N-5160	.2 MFD 200V -10x10x5	N-4022	33 OHM .5W 20%
C14 N-1346	.05 MFD 400V	N-4068	470 OHM .5W 10%
C15 N-1351	.1 MFD 200V -10x20x5		
C16 N-1342	50 MMFD MICA	1 N-3374	LOOP COIL
R1 N-5351	22,000 OHM .5W INS. 20%	2 N-4842	1ST I.F. TRANSFORMER
R2 N-4276	4,700 OHM .5W 10%	3 N-5371	2ND I.F. TRANSFORMER
R3 N-4087	47,000 OHM .5W INS. 20%	4 N-4875	OUTPUT TRANSFORMER
R4 N-5351	22,000 OHM .5W INS. 20%	5 N-4868	15 SPEAKER
R5 N-4824	15 MEGOHM .5W INS. 20%	6 N-5552	2 SECTION TRIMMER

Sentinel Radio

MODEL 292K

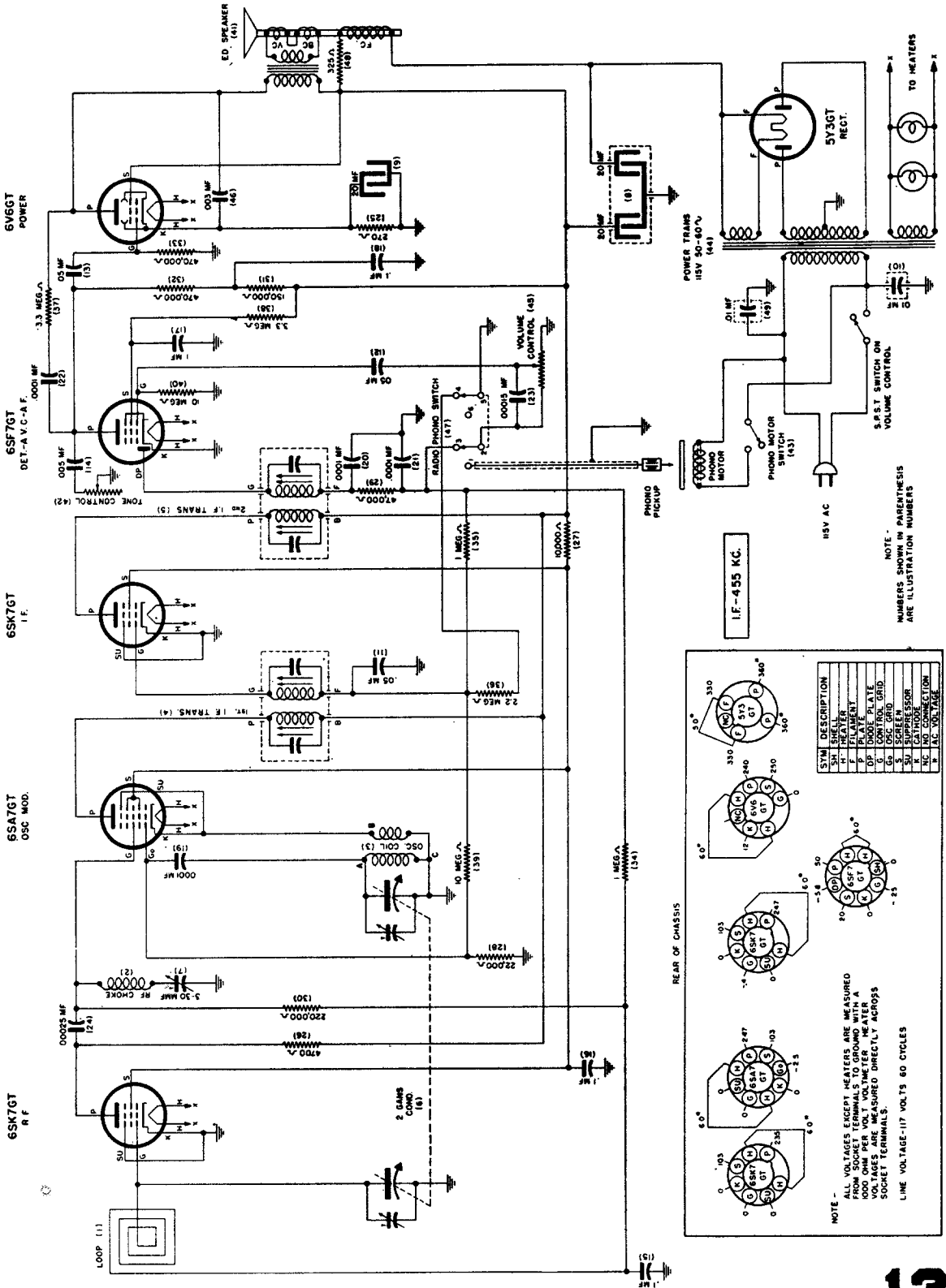

NOTE -
NUMBERS SHOWN IN PARENTHESES
ARE ILLUSTRATION NUMBERS

REAR OF CHASSIS

SYM	DESCRIPTION
S	5Y3 RECT.
P	6V6GT
F	6SA7GT
G	6SK7GT
DP	DOCK PLATE
D	OSC GRID
G	OSC GRID
S	SCREEN GRID
K	CONTROL GRID
W	WAX TUBES
HC	HEATER CONNECTION
HE	HEATER
AC	AC VOLTAGE

NOTE -
ALL VOLTAGES EXCEPT METERS ARE MEASURED
WITH A 100 OHM PER VOLT METER ACROSS
VOLTAGE ARE MEASURED DIRECTLY ACROSS
SOCKET TERMINALS.
LINE VOLTAGE-117 VOLTS 60 CYCLES

VOLTAGE TABLE
(BOTTOM VIEW OF CHASSIS)

Sentinel

MODEL 292K

For Alignment procedure read tabulations from left to right, and make the adjustment marked (1) first, (2) next, (3) third. **IMPORTANT: BEFORE ALIGNING, HAVE LOOP ANTENNA IN THE SAME POSITION IT WILL BE IN WHEN THE SET IS IN THE CABINET. BE SURE THAT IT DOES NOT MOVE WHILE ALIGNING.**

When adjusting 1650 kilocycle oscillator trimmer, 455 K.C. R.F. trimmer and 1400 kilocycle antenna trimmer, connect test oscillator to loop external antenna and ground connections with a .0002 Mfd. capacitor in series with antenna lead.

TEST OSCILLATOR			
Set receiver dial to:	Adjust test oscillator frequency to:	Use dummy antenna in series with output of test oscillator consisting of:	Attach output of test oscillator to
550 g.			Refer to parts layout diagram for location of trimmers mentioned below:
Any point where no interfering signal is received	Exactly 455 K. C.	0.2 Mfd. Condenser	High side to grid of 6SA7 Tube. Low side to chassis.
1 Rotate gang condenser to maximum capacity	Exactly 455 K. C.	.0002 Mfd. Condenser	To loop external antenna and ground connections
2 Rotate gang condenser to minimum capacity	Exactly 1650 K. C.	.0002 Mfd. Condenser	To loop external antenna and ground connections
3 Approximately 1400 K. C.	Approx. 1400 K. C.	.0002 Mfd. Condenser	To loop external antenna and ground connections
			Adjust R.F. coil trimmer for <u>minimum</u> 455 K. C. signal.
			Adjust 1650 K. C. oscillator trimmer for maximum output.
			Adjust 1400 K. C. antenna trimmer for maximum output.

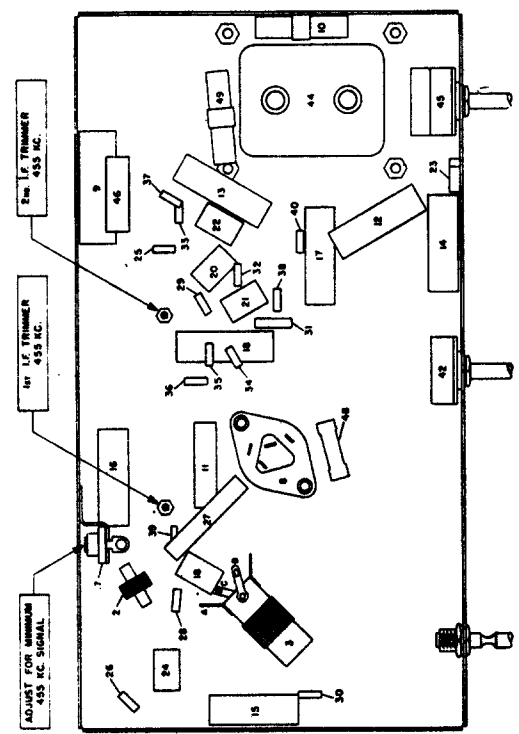
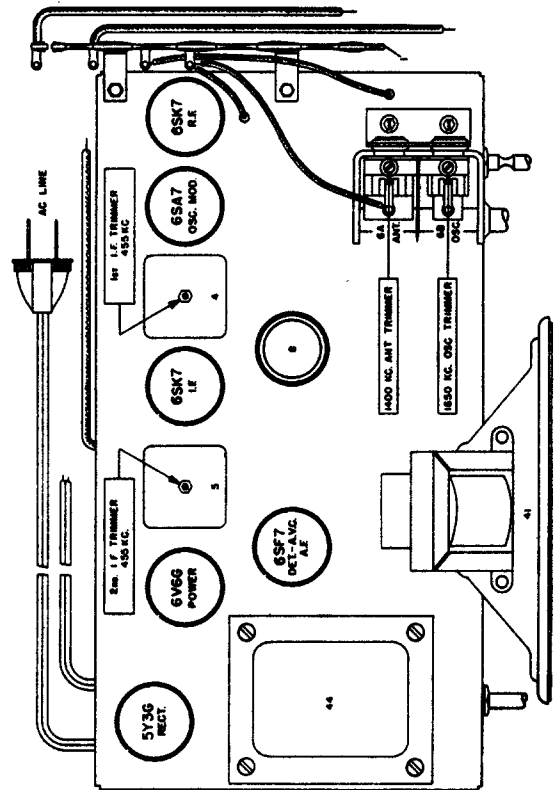

MANUAL OF 1947 MOST-OFTEN-NEEDED RADIO DIAGRAMS

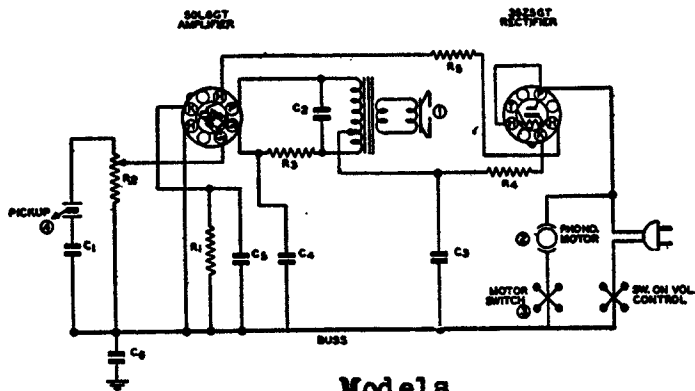

**Models
RWF/RWFU (78 & 238)**

PART NO.	DESCRIPTION	PART NO.	DESCRIPTION
R1	100 OHM 5.0% 10%	①	4" PM DYNAMIC SPKR.
R2	10-2000 470 OHM 5.0% 10%	②	OUTPUT TRANSF.
R3	10-2000 470 OHM 5.0% 10%	③	PHONE MOTOR
R4	10-2000 100 OHM 5% 10%	④	ALTERN.
R5	10-2000 200 OHM 5% 10%	⑤	MOTOR SWITCH
		⑥	PHONE PICKUP
		⑦	ALTERN.
C1	10-1000 .05 MFD.	200V	
C2	10-1000 .05 MFD.	400V	
C3	10-1000 .05 MFD.	400V	
C4	10-2000 .05 MFD. ELECT.	500V	
C5	10-2000 .05 MFD.	500V	
C6	10-2000 .05 MFD.	500V	

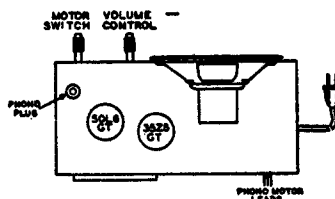

ALIGNMENT

Operation	Connect Oscillator To:	Dummy Ant.	Set Osc. To:	Set Dial To:	Adjust Trimmers	Purpose
1	Converter Grid	.05 MFD.	455 KC	Min. Cap.	C, D, E	Align IF
2	Antenna	100 MMF.	1620 KC	Min. Cap.	B	Set Oscillator
3	Antenna	100 MMF.	1400 KC	1400 KC	A	Adjust Ant.
4	Antenna	100 MMF.	600 KC	600 KC	Check Calibration



**Models
RYM/RYMU (224)**

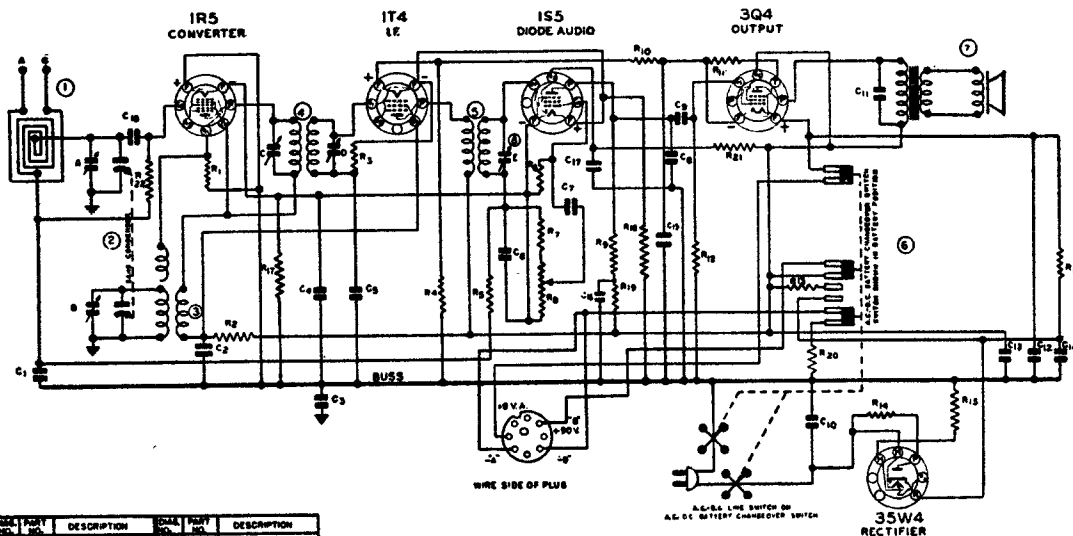

PART NO.	DESCRIPTION	PART NO.	DESCRIPTION
C1	10-2000 .05 MFD. 500V 20%	R1	10-2000 100,000 OHM 5% 10%
C2	10-2000 .05 MFD. 1000V 20%	R2	10-2000 10,000 OHM 5% 10%
C3	10-2000 .05 MFD. 200V 10%	R3	10-2000 50 MEG OHM 5% 20%
C4	10-2000 .05 MFD. 200V 10%	R4	10-2000 500 OHM 5% 10%
C5	10-2000 .05 MFD. 200V 10%	R5	10-2000 20 MEG OHM 5% 20%
C6	10-2000 .05 MFD. 200V 10%	R6	10-2000 10 MEG OHM 5% 20%
C7	10-2000 .05 MFD. 200V 10%	R7	10-2000 47,000 OHM 5% 20%
C8	10-2000 .05 MFD. 200V 10%	R8	10-2000 100 OHM 5% 10%
C9	10-2000 .05 MFD. 200V 10%	R9	10-2000 100,000 OHM 5% 10%
C10	10-2000 .05 MFD. 200V 10%	R10	10-2000 15 OHM 5% 10%
C11	10-2000 .05 MFD. 200V 10%	R11	10-2000 330 OHM 5% 10%
C12	10-2000 .05 MFD. 200V 10%	R12	10-2000 22 MEG OHM 5% 20%
C13	10-2000 .05 MFD. 200V 10%	R13	10-2000 1,500 OHM 5% 10%
C14	10-2000 .05 MFD. 200V 10%	R14	10-2000 50 OHM 5% 10%
C15	10-2000 .05 MFD. 200V 10%	R15	10-2000 200 OHM 5% 10%
C16	10-2000 .05 MFD. 200V 10%	R16	10-2000 1,500 OHM 5% 10%
C17	10-2000 .05 MFD. 200V 10%	R17	10-2000 1,500 OHM 5% 10%
C18	10-2000 .05 MFD. 200V 10%	R18	10-2000 2,200 OHM 5% 20%
C19	10-2000 .05 MFD. 200V 10%	R19	10-2000 100,000 OHM 5% 10%
C20	10-2000 .05 MFD. 200V 10%	R20	10-2000 10 OHM 5% 10%
C21	10-2000 .05 MFD. 200V 10%	R21	10-2000 20 MEG OHM 5% 20%
C22	10-2000 .05 MFD. 200V 10%	R22	10-2000 10 OHM 5% 10%
C23	10-2000 .05 MFD. 200V 10%	R23	10-2000 22 MEG OHM 5% 20%

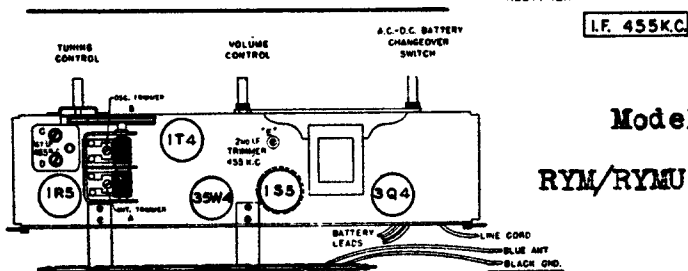

**Models
RYM/RYMU (224)**

MANUAL OF 1947 MOST-OFTEN-NEEDED RADIO DIAGRAMS

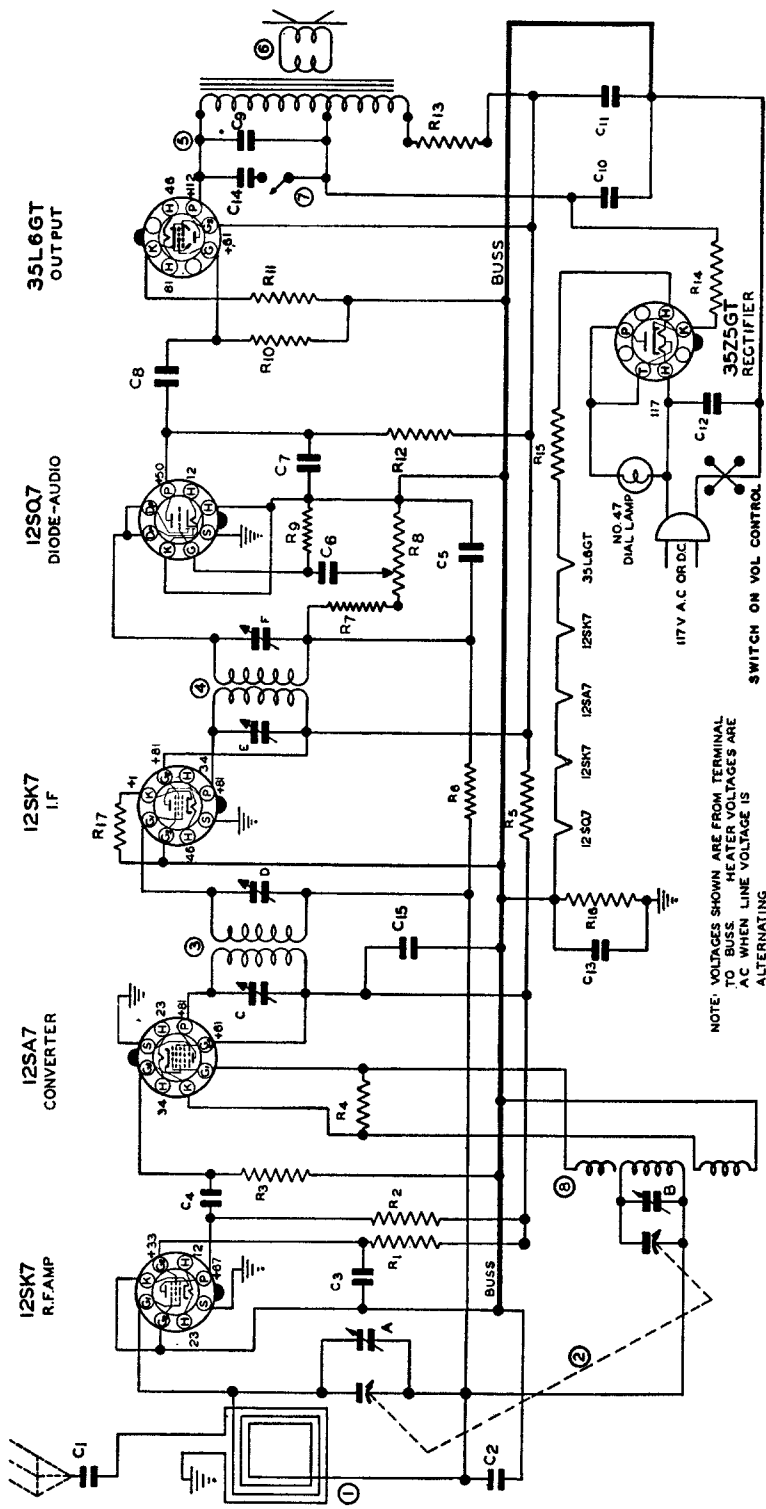

NOTE: VOLTAGES SHOWN ARE FROM TERMINAL TO BUSS. HEATER VOLTAGES ARE AC WHEN LINE VOLTAGE IS ALTERNATING

DIAL PART NO.	DESCRIPTION	DIAL PART NO.	DESCRIPTION
C1	.01 MFD 400V	N-1282	1 MEG OHM .5W 20%
C2	.05 MFD 200V	N-4063	47,000 OHM .5W 10%
C3	.05 MFD 200V	N-5026	0.5 MEG OHM VOL. CONT.
C4	150 MMFD MICA	N-4061	47 MEG OHM .5W 20%
C5	100 MMFD MICA	N-4027	470,000 OHM .5W 20%
C6	N-4894 .005 MFD 600V	N-4067	180 OHM .5W 10%
C7	N-4890 .0005 MFD 600V	N-4989	220,000 OHM .5W INS. 10%
C8	N-1344 .01 MFD 400V	N-4900	1200 OHM 1W 10%
C9	N-1344 .01 MFD 400V	N-4022	33 OHM .5W 20%
C10	40 MFD 150 W.V. ELECTRO	R 15	N-4638 33 OHM 1W 10%
C11	N-1346 .05 MFD 400V	R 16	N-4029 220,000 OHM .5W 20%
C12	N-5160 .2 MFD 200V	R 17	N-5857 82 OHM .5W 10%
C13	N-1346 .05 MFD 400V	R 18	N-5937 LOOP COIL
C14	N-1346 .05 MFD 400V	R 19	N-4061 GANG CONDENSER
C15	N-1351 1 MFD 200V	(1)	N-5765 LOOP COIL
R1	N-4063 47,000 OHM .5W 10%	(2)	N-5936 2 GANG CONDENSER
R2	N-4896 2200 OHM .5W 10%	3	N-4872 1ST I.F. TRANSFORMER
R3	N-4087 47,000 OHM .5W INS. 20%	4	N-5371 2ND I.F. TRANSFORMER
R4	N-5351 22,000 OHM .5W INS. 20%	5	N-4875 OUTPUT TRANSFORMER
R5	N-4068 470 OHM .5W 10%	6	N-4866 5 SPEAKER
		7	N-4942 TONE SWITCH
		8	N-4810 OSCILLATOR COIL

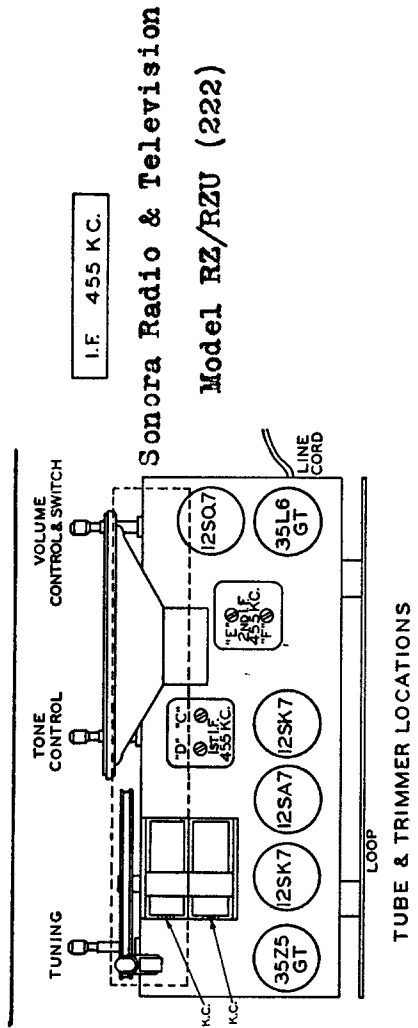

Sonora Radio & Television
Model RZ/RZU (222)

TUBE & TRIMMER LOCATIONS

MANUAL OF 1947 MOST-OFTEN-NEEDED RADIO DIAGRAMS

SPARTON SUPERHETERODYNE MODEL 7-46 & 7-46 PA. & 846 & 846 PA
INTERMEDIATE FREQUENCY 456 K.C.

BOTTOM VIEWS OF ALL SOCKET CONNECTIONS

WAVE BAND SWITCH-FB42002
SHOWN IN BC POSITION

SWITCH WAFERS IDENTIFIED BY
NUMBERING FROM SHOWN AND
BY LETTERS AS INDICATED
BY LETTERS A REAR VIEW BY
LETTER W

RE AMP
7A7

OSC. & CONK.
7B7

IF AMP
7A7

DET AVCA/1ST AUDIO
7B6

PUSH PULL OUTPUT
TWO 6F60/OT

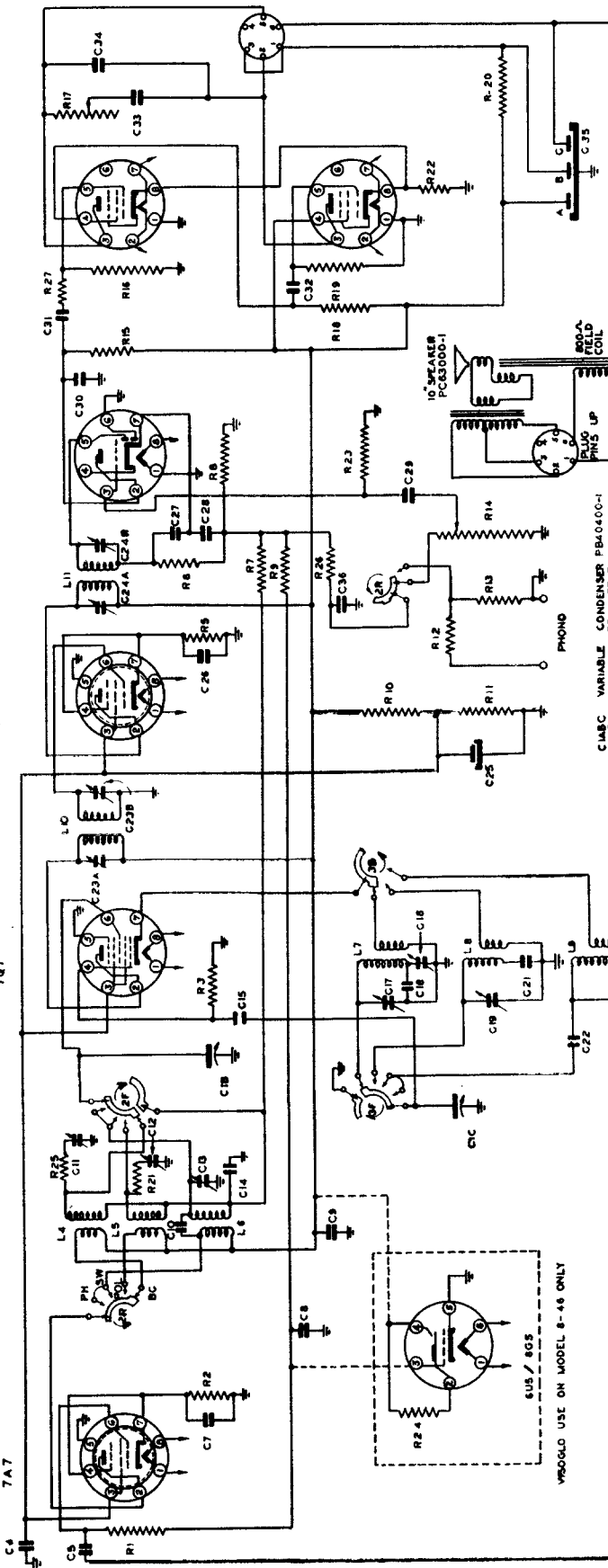

- | | | |
|------|----------|------------|
| C18C | VARIABLE | FBL040C-1 |
| C2 | BC ANT | PA435B-1 |
| C3 | TRIMMER | MC60G-241 |
| C4 | TRIMMER | PC40HL-503 |
| C5 | TRIMMER | PC40HK-503 |
| C6 | TRIMMER | PC40HL-503 |
| C7 | TRIMMER | MC60G-080 |
| C8 | TRIMMER | MICA |
| C9 | TRIMMER | MICA |
| C10 | TRIMMER | PA435B-2 |
| C11 | TRIMMER | PC40HK-503 |
| C12 | TRIMMER | MC60G-241 |
| C13 | TRIMMER | MC60G-510 |
| C14 | TRIMMER | MC60G-510 |
| C15 | TRIMMER | MC60G-510 |
| C16 | TRIMMER | MC60G-510 |
| C17 | TRIMMER | MC60G-510 |
| C18 | TRIMMER | MC60G-510 |
| C19 | TRIMMER | MC60G-510 |
| C20 | TRIMMER | MC60G-510 |
| C21 | TRIMMER | MC60G-510 |
| C22 | TRIMMER | MC60G-510 |
| C23 | TRIMMER | MC60G-510 |
| C24 | TRIMMER | MC60G-510 |
| C25 | TRIMMER | MC60G-510 |
| C26 | TRIMMER | MC60G-510 |
| C27 | TRIMMER | MC60G-510 |
| C28 | TRIMMER | MC60G-510 |
| C29 | TRIMMER | MC60G-510 |
| C30 | TRIMMER | MC60G-510 |
| C31 | TRIMMER | MC60G-510 |
| C32 | TRIMMER | MC60G-510 |
| C33 | TRIMMER | MC60G-510 |
| C34 | TRIMMER | MC60G-510 |
| C35 | TRIMMER | MC60G-510 |
| C36 | TRIMMER | MC60G-510 |
| C37 | TRIMMER | MC60G-510 |
| C38 | TRIMMER | MC60G-510 |
| C39 | TRIMMER | MC60G-510 |

- | | |
|-----|------------|
| R1 | 1 MEGOHM |
| R2 | 500K OHM |
| R3 | DELTA |
| R4 | 500 OHM |
| R5 | 3.3 MEGOHM |
| R6 | 100K OHM |
| R7 | 3.3 MEGOHM |
| R8 | 100K OHM |
| R9 | 100K OHM |
| R10 | 200K OHM |
| R11 | 200K OHM |
| R12 | 200K OHM |
| R13 | 200K OHM |
| R14 | 200K OHM |
| R15 | 200K OHM |
| R16 | 200K OHM |
| R17 | 200K OHM |
| R18 | 200K OHM |
| R19 | 200K OHM |
| R20 | 100K OHM |
| R21 | 100K OHM |
| R22 | 100K OHM |
| R23 | 100K OHM |
| R24 | 100K OHM |
| R25 | 330 OHM |
| R26 | 100K OHM |
| R27 | 100K OHM |
| R28 | 100K OHM |
| R29 | 100K OHM |
| R30 | 100K OHM |
| R31 | 100K OHM |
| R32 | 100K OHM |
| R33 | 100K OHM |
| R34 | 100K OHM |
| R35 | 100K OHM |
| R36 | 100K OHM |
| R37 | 100K OHM |
| R38 | 100K OHM |
| R39 | 100K OHM |

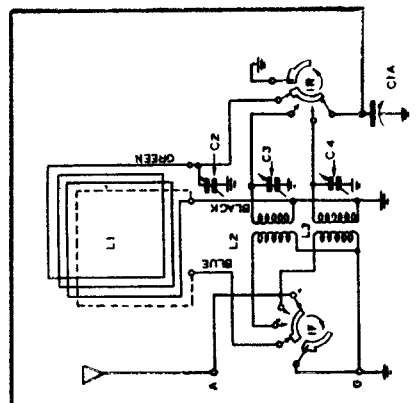

PROGLO USE ON MODEL 8-46 ONLY

MANUAL OF 1947 MOST-OFTEN-NEEDED RADIO DIAGRAMS

Sparton Superheterodyne Model 7-46 & 7-46-PA & 846 & 846-PA

OPERATION	ALIGNMENT OF	GENERATOR CONNECTED TO	DUMMY ANTENNA	GENERATOR FREQUENCY	BAND SWITCH SETTING	TUNING CONDENSER SETTING	TRIMMERS	REMARKS
1	I.F.	*	1-mf cond.	450KC	BC	Open	C24 A&B C25 A&B	Peak Accurately " "
2	Broadcast Band	Ant.	See note	1500KC	BC	1500KC	C17 Osc.Trim C11 Det.Trim	" " " "
3				600KC	BC	600KC	C2 Ant.Trim	" "
4							C18 Osc.Pad	Rock **
5								(Repeat operation 3).
6								Check Calibration at 600 KC, 1000 KC and 1500 KC.
7	Police Band	Ant.	See note	5 MC	Police Band	5 MC	C19 Osc.Trim C12 Det.Trim C3 Ant.Trim	Peak Accurately Rock ** Rock **
8							C21 Osc.Pad	See operation #8
9								Oscillator Padder C21 is precision set at the factory and should not be readjusted in the field. (Repeat operation 7).
10								Check Calibration at 1.8 MC and 5 MC.
11	SW Band	Ant.	See note	18 MC	SW Band	18 MC	C20 Osc.Trim C15 Det.Trim C4 Ant.Trim	Peak Accurately Rock ** Rock **
12							C22 Osc.Pad	See operation #12
13								Oscillator Padder C22 is precision set at the factory and should not be readjusted in the field. (Repeat operation 11).
14								Check Calibration and at 6 MC and 18 MC.
15								Check operations 1 to 11 inclusive.

NOTES: Use Dummy Antenna as described.
* Connect generator to pin #6 on 7Q7 Osc-conv. tube.
** Rock dial while adjusting for maximum output.

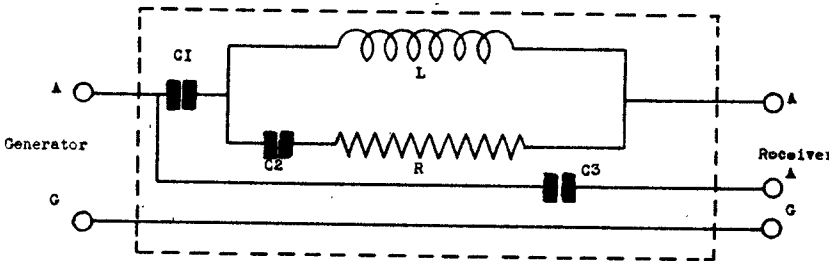
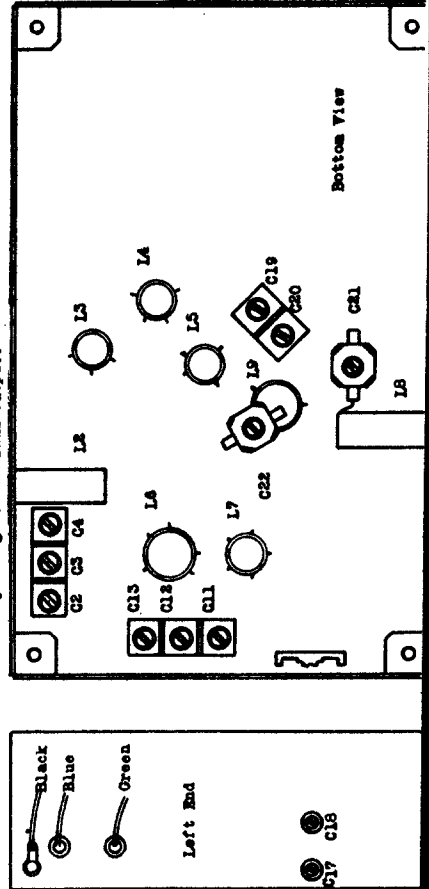

DUMMY ANTENNA

- C1 - 200 mmf. Condenser 400 V.D.C.
- C2 - 400 mmf. Condenser 400 V.D.C.
- C3 - .02 mmf. Condenser 400 V.D.C.
- R - 100 Ohms Resistor 1/4 Watt
- L - 20 Microhenryss Choke

---- Case Shield
Choke Coil Specifications
Tubing - 3/8" diameter bakelite
Wire - No. 38 Enameled
Turns - 59 closely wound (Impregnated)

TUBE		FUNCTION	Voltage of socket prongs to Gnd, See prong on schematic dia.							
			No. 1	No. 2	No. 3	No. 4	No. 5	No. 6	No. 7	No. 8
Line Voltage: 117 Volts A.C.			Position of Volume Control: Full with dial tuned to Quiet Channel							
			Position of Band Switch: Broadcast							
7A7	R. F. Amp.		0	230	63	2.8	0	**	2.8	6*
7Q7	Osc-Conv.		0	230	63	-6	0	-.6	"	6*
7A7	I. F. Amp.		0	230	63	2.3	0	**	2.3	6*
7B6	Det-AVC-1st Audio		0	100	**	0	**	0	0	6*
6F6	Push Pull Output		0	0	247	220	**	**	6*	14
6F6	Push Pull Output		0	0	247	227	**	0	6*	14
5Y3	Rectifier		0	325	0	320*	0	320*	0	325

NOTES: Voltage readings are for schematic diagram in this bulletin. Allow 15% + or - on all measurements. Always use meter scale which will give greatest deflection within scale limits. All DC measurements made with 20,000 ohms per volt voltmeter. All AC voltages made with rectifier type voltmeter.
* AC Volts.
** Cannot be measured with 20,000 Ohms per volt voltmeter.

MANUAL OF 1947 MOST-OFTEN-NEEDED

SPARTON SUPERHETERODYNE MODEL 526 526X & 526PS. INTERMEDIATE FREQUENCY 456 KC. BOTTOM VIEW OF ALL SOCKET CONNECTIONS

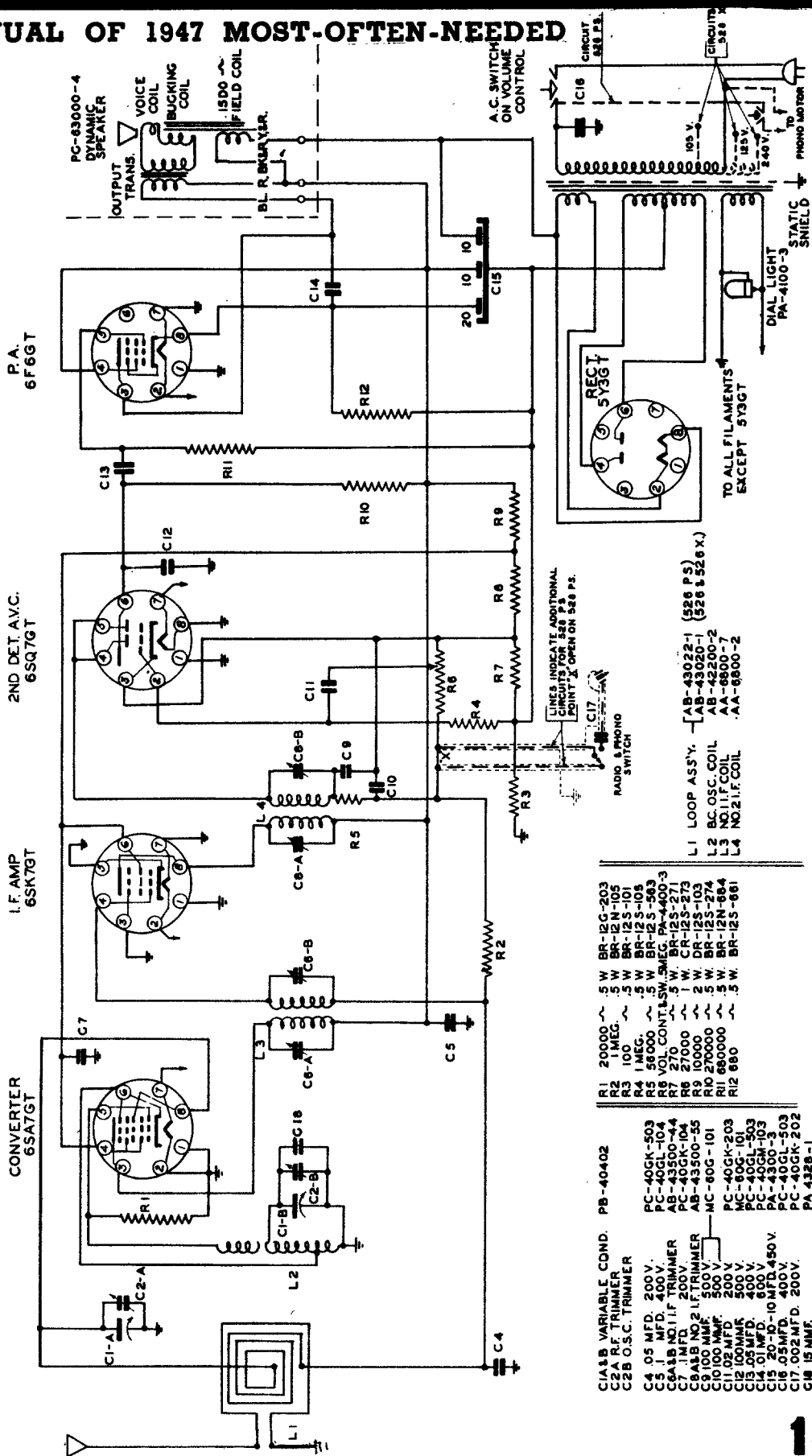

- C1A 1/2 VARIABLE COND. PB-40402
 C2A 1/2 TRIMMER
 C2B O.S.C. TRIMMER
 C4 .05 MFD. 200V.
 C5 1 MFD. 400V.
 C6A 1/2 MFD. 200V.
 C6B 1/2 MFD. 200V.
 C7 100 MFD. 50V.
 C8 100 MFD. 50V.
 C9 100 MFD. 50V.
 C10 .01 MFD. 500V.
 C11 .02 MFD. 200V.
 C12 .005 MFD. 500V.
 C13 .01 MFD. 500V.
 C14 .01 MFD. 500V.
 C15 .01 MFD. 500V.
 C16 .01 MFD. 500V.
 C17 .002 MFD. 200V.
 C18 .15 MFD.
- PB-40402
 PC-40GK-503
 PC-40GL-104
 AB-43500-44
 PC-40GK-104
 AB-43500-35
 MC-60G-101
 PC-40GK-203
 MC-60G-101
 PC-40GL-503
 PC-40GM-103
 PC-40CO-203
 PC-40GK-202
 PA-4328-1
- R1 20000 ~ 5 W BR-12G-203
 R2 1 MEG. ~ 5 W BR-12M-105
 R3 100 ~ 5 W BR-12S-101
 R4 1 MEG. ~ 5 W BR-12S-105
 R5 56000 ~ 5 W BR-12S-503
 R6 VOL. CONT. SW. SMEG. PA-4400-3
 R7 270 ~ 5 W BR-12S-271
 R8 27000 ~ 1 W CR-12S-273
 R9 150000 ~ 2 W DR-12S-274
 R10 270000 ~ 5 W BR-12N-664
 R11 680000 ~ 5 W BR-12S-661
 R12 880 ~ 5 W BR-12S-661
- L1 LOOP ASS'Y. [AB-43022-1 (526 PS)
 AB-43020-1 (526 & 526X.)
 L2 BC OSC. COIL AB-42200-2
 L3 NO. 11 F. COIL AA-6800-7
 L4 NO. 2 I.F. COIL AA-6800-2

THE SPARKS-WITHINGTON COMPANY

SERVICE DATA FOR STEWART-WARNER MODELS 51T46, 51T56

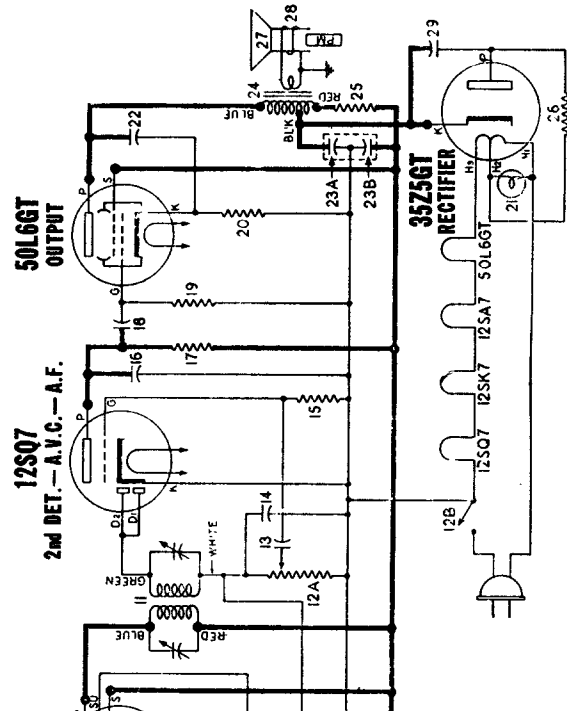

SOCKET VOLTAGES

Measured with voltmeter having sensitivity of 1000 ohms per volt except where indicated by (*).

VOLUME ON FULL WITH NO SIGNAL DIAL TUNED TO 540 KC.

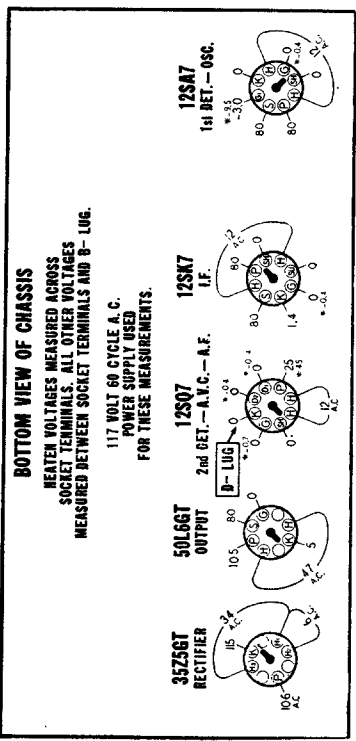

REAR OF CHASSIS

*—Measured with vacuum tube voltmeter

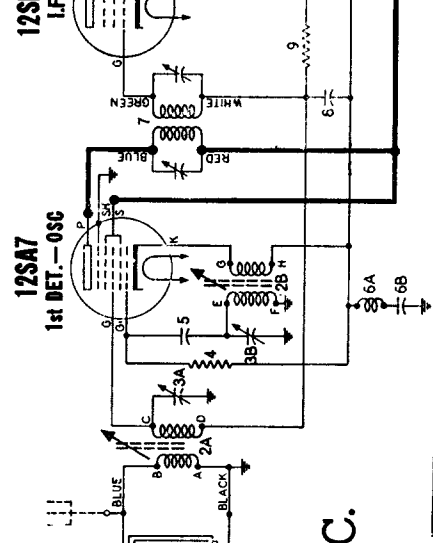

I.F. 455 KC.

DIA-GRAM NO.	PART NO.	DESCRIPTION
3A, B	.504330	Condenser—metal assembly A-20 to 270 Mmfd. B-40 to 370 Mmfd.
5	.502981	Condenser—100 Mmfd. 500 volt.
6B	.502158	Condenser—2 Mfd. 400 volt.
8	.502153	Condenser—.05 Mfd. 200 volt.
13	.502156	Condenser—.004 Mfd. 400 volt.
14	.502882	Condenser—.220 Mmfd. 500 volt.
16	.502470	Condenser—.0008 Mfd. 400 volt.
18	.502156	Condenser—.004 Mfd. 400 volt.
22	.502152	Condenser—.02 Mfd. 400 volt.
23-A, B	.500256	Condenser—electrolytic A-40 Mfd. 150 volt. B-20 Mfd. 150 volt.
29	.502157	Condenser—.05 Mfd. 400 volt.
4	.502130	Resistor—carbon 22,000 ohms 1/4 watt.
6	.502135	Resistor—carbon 2.2 Meg. 1/4 watt.
10	.502134	Resistor—carbon 47 ohms 1/4 watt.
12A, B	.502828	Volume control—with switch, 1 Meg.
17	.502136	Resistor—carbon 10 Meg. 1/4 watt.
19	.502134	Resistor—carbon 470,000 ohms 1/4 watt.
20	.502134	Resistor—carbon 470,000 ohms 1/4 watt.
23	.502823	Resistor—carbon 1,500 ohms 1 watt.
26	.502374	Resistor—carbon 33 ohms 1/2 watt.
1	.504348	COILS AND TRANSFORMERS Loop antenna
2-A, B	.504335	Tuning unit; complete assembly
2A	.504760	Coil—antenna (less slug)
2-B	.504212	Coil—oscillator (less slug)
504211		Slug for Ant. coil (yellow end)
504213		Slug for Osc. coil (white end)
6A		Choke; three turns of #22 insulated wire closely wound on condenser 6B.
7	.502926	Transformer—1st I.F.
11	.502927	Transformer—2nd I.F.
24	.502817	Transformer—output for C-502816 speaker.
24	.504583	Transformer—output for W-502816 speaker.
21	.118921	Lamp—dial (Mazda 47) 6-8V. 150 Ma.

Lettered terminals in illustrations correspond to similarly lettered terminals on the circuit diagram.

DIAL AND POINTER DRIVE CORD ARRANGEMENT

To string dial cord, turn the main drive drum to maximum counter-clockwise position and use following parts:
 114955 Clip on end of cord
 117057 Cord (54 inches)
 119087 Ring for dial cord
 161384 Tension Spring

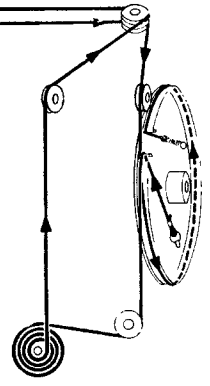

STEWART-WARNER MODELS 51T126, 51T136, 51T146, 51T176

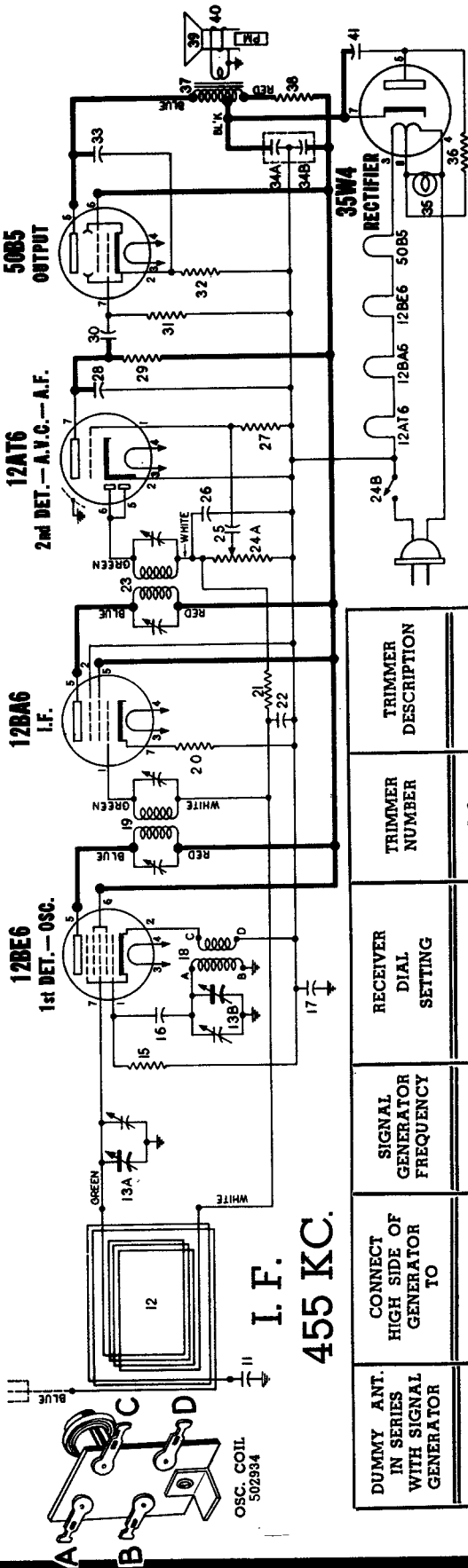

DUMMY ANT. IN SERIES WITH SIGNAL GENERATOR	CONNECT HIGH SIDE OF GENERATOR TO	SIGNAL GENERATOR FREQUENCY	RECEIVER DIAL SETTING	TRIMMER NUMBER	TRIMMER DESCRIPTION
200 MMFD. Mica Condenser	Trimmer on rear section of gang.	455 KC	Any point where it does not affect the signal.	1-2	2nd I.F.
200 MMFD. Mica Condenser	External antenna lead on loop.	1500 KC	1500 KC	3-4	1st I.F.
200 MMFD. Mica Condenser	External antenna lead on loop.	1500 KC	Tune to 1500 KC generator signal.	5	Broadcast Oscillator
				6	Broadcast Antenna

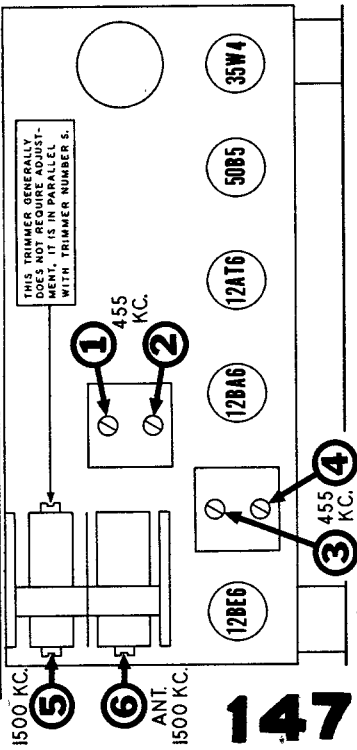

DIA. GRAM NO.	PART NO.	DESCRIPTION
CONDENSERS		
11	502151	Condenser--01 Mfd. 400 volt.
13-A, B	502925	Condenser-variable gang (with drum)
16	502929	Condenser-mica 47 Mmfd. 500 volt.
17	502158	Condenser--2 Mfd. 400 volt.
22	502153	Condenser--05 Mfd. 200 volt.
25	502156	Condenser--004 Mfd. 400 volt.
26	502982	Condenser--220 Mmfd. 500 volt.
28	502970	Condenser--0008 Mfd. 400 volt.
30	502156	Condenser--004 Mfd. 400 volt.
33	502152	Condenser--02 Mfd. 400 volt.
34-A, B	500236	Condenser-electrolytic A-40 Mfd. 150 volt B-20 Mfd. 150 volt
41	502157	Condenser--05 Mfd. 400 volt.
RESISTORS		
15	502130	Resistor-carbon 22,000 ohms 1/4 watt.
20	502456	Resistor-carbon 220 ohms 1/4 watt.
21	502135	Resistor-carbon 2.2 Meg. 1/4 watt.
24-A, B	502928	Volume control--with switch: 1 Meg.
27	502136	Resistor-carbon 10 Meg. 1/4 watt.
29	502134	Resistor-carbon 470,000 ohms 1/4 watt.
31	502134	Resistor-carbon 470,000 ohms 1/4 watt.
32	502932	Resistor-carbon 150 ohms 1 watt.
36	502374	Resistor-carbon 35 ohms 1/2 watt.
38	502933	Resistor-carbon 150 ohms 1 watt.
OTHER ELECTRICAL PARTS		
35	118921	Lamp-dial (Merida 47) 6-8V. 150 Ma.
39	504584	Cone & voice coil for W-502816 speaker
40	502818	Cone & voice coil for C-502816 speaker
	502816	Speaker--P.M. dynamic (4 inch).

DATA FOR STEWART-WARNER MODELS 61TR36, 61TR46

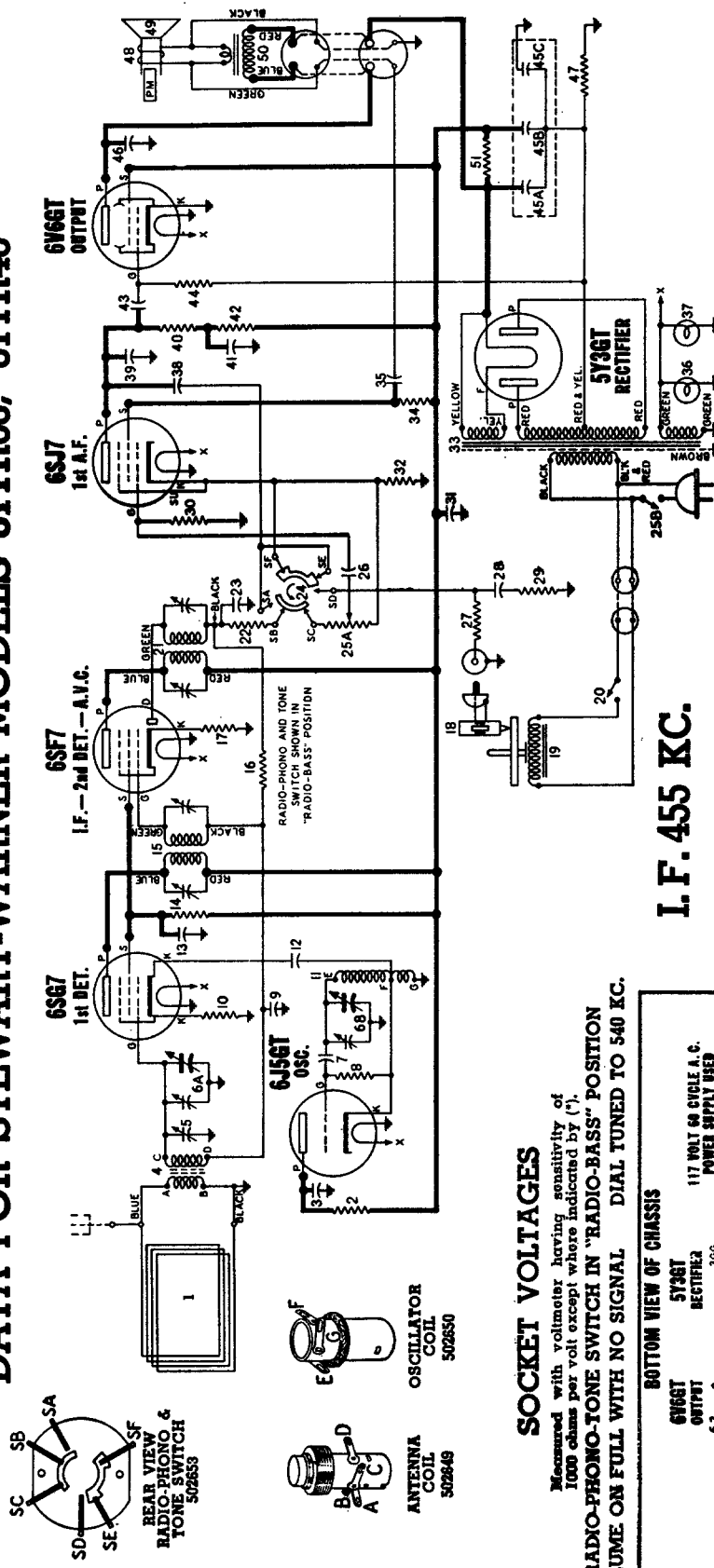

I. F. 455 KC.

SOCKET VOLTAGES

Measured with voltmeter having sensitivity of 1000 ohms per volt except where indicated by (*).

RADIO-PHONO-TONE SWITCH IN "RADIO-BASS" POSITION
VOLUME ON FULL WITH NO SIGNAL DIAL TUNED TO 540 KC.

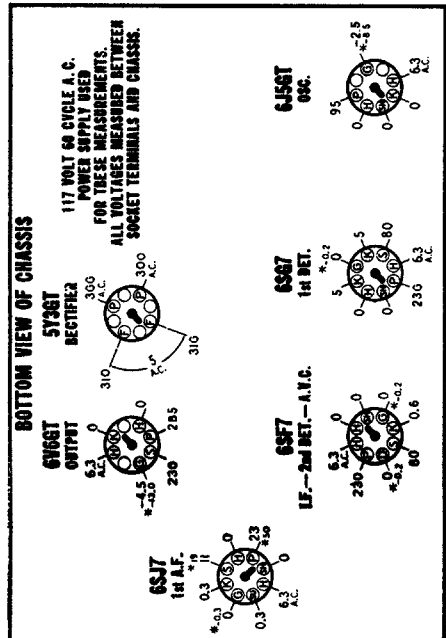

*—Measured with vacuum tube voltmeter.

NOTE:—The 6V6GT grid bias of—13 volts can be measured across resistor No. 47.

DIA. GRAM NO.	PART NO.	DESCRIPTION
3	502151	Condenser—.01 Mfd. 400 volt.
5	502651	Condenser—trimmer 12 to 18 Mmfd.
6A, B,	502652	Condenser—variable gang and drum.
7	502160	Condenser—mic.—110 Mmfd. 500 volt.
9	502153	Condenser—.05 Mfd. 200 volt.
12	502151	Condenser—.01 Mfd. 400 volt.
13	502157	Condenser—.05 Mfd. 400 volt.
23	502160	Condenser—mic 110 Mmfd. 500 volt.
26	502156	Condenser—.004 Mfd. 400 volt.
28	502479	Condenser—.006 Mfd. 600 volt.
31	502157	Condenser—.05 Mfd. 400 volt.
35	502405	Condenser—.25 Mfd. 400 volt.
38	502150	Condenser—.004 Mfd. 600 volt.
39	502271	Condenser—mic.—260 Mmfd. 500 volt.
41	502410	Condenser—.1 Mfd. 400 volt.
43	502152	Condenser—.02 Mfd. 400 volt.
45A, B, C,	502207	Condenser—electrolytic A — 20 Mfd. 400 volt B — 10 Mfd. 400 volt C — 20 Mfd. 25 volt
46	502156	Condenser—.004 Mfd. 400 volt.
2	502468	Resistor—carbon—33,000 ohms 1 watt.
6	502131	Resistor—carbon—47,000 ohms 1/4 watt.
10	502514	Resistor—carbon—3,300 ohms 1/4 watt.
14	502288	Resistor—carbon—47,000 ohms 1/4 watt.
17	502265	Resistor—carbon—33 Meg. 1/4 watt.
18	502264	Resistor—carbon—47,000 ohms 1/4 watt.
22	502133	Resistor—carbon—47,000 ohms 1/4 watt.
25A, B,	502134	Volume control—47,000 ohms 1/4 watt.
27	502153	Resistor—carbon—270,000 ohms 1/4 watt.
29	502468	Resistor—carbon—58,000 ohms 1/4 watt.
30	502468	Resistor—carbon—47 Meg. 1/4 watt.
32	502468	Resistor—carbon—1,500 ohms 1/4 watt.
34	502468	Resistor—carbon—2.5 Meg. 1/4 watt.
40	502133	Resistor—carbon—220,000 ohms 1/4 watt.
42	502133	Resistor—carbon—220,000 ohms 1/4 watt.
44	502134	Resistor—carbon—470,000 ohms 1/4 watt.
47	502453	Resistor—wire wound—200 ohms 2 watt.
51	504771	Resistor—carbon—3,300 ohms 2 watt.
1	502697	Loop antenna and cabinet back.
4	502649	Coil—antenna
11	502650	Coil—oscillator
15	502657	Transformer—1st I.F.
21	502658	Transformer—2nd I.F.
33	502174	Transformer—power

RESISTORS

CONDENSERS

COILS AND TRANSFORMERS

SERVICE DATA FOR STEWART-WARNER MODEL 62T36

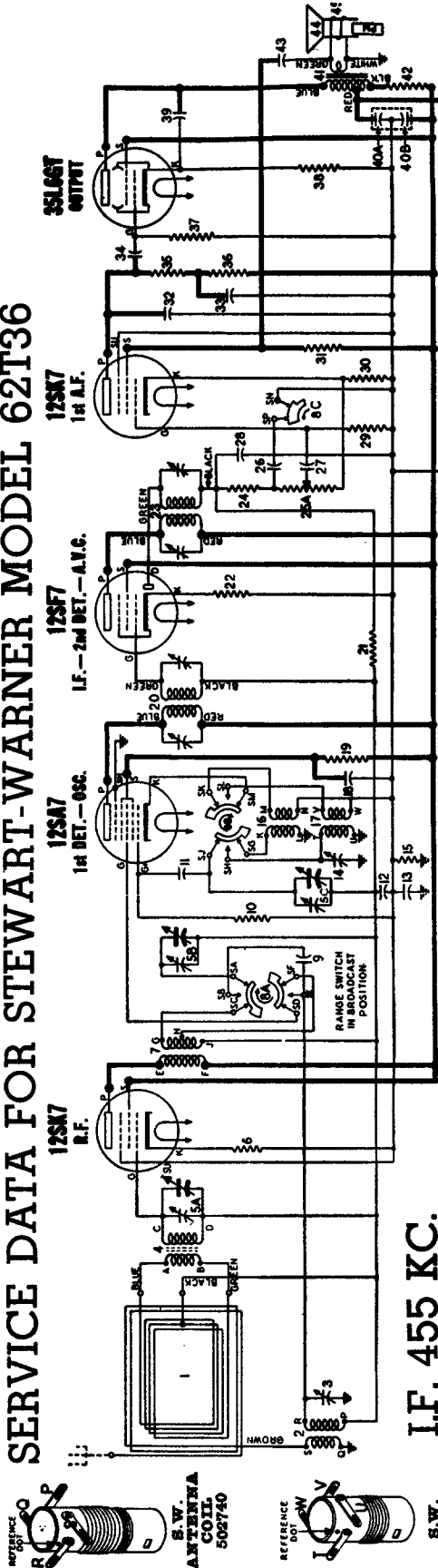

I.F. 455 KC.

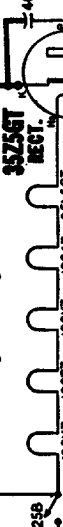

Lettered terminals in illustrations correspond to similar terminals on the circuit diagram.

SOCKET VOLTAGES

Measured with voltmeter having sensitivity of 1000 ohms per volt except where indicated by (*).

VOLUME ON FULL WITH NO SIGNAL DIAL TUNED TO 540 KC.

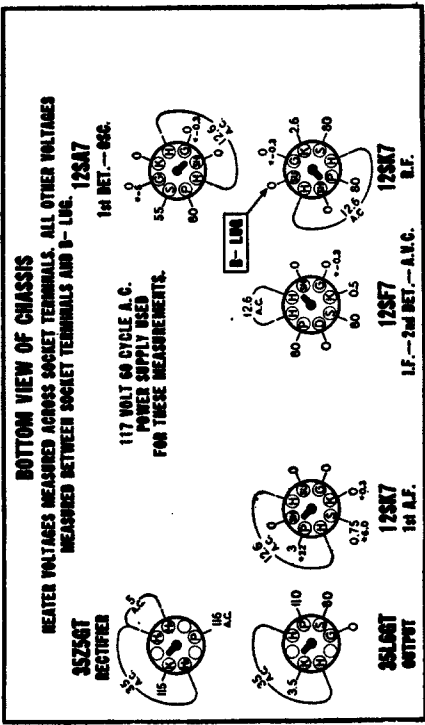

CONDENSERS	
3	502172 Condenser—trimmer: 25 to 100 Mmfd.
5A, 5B-5C	502123 Condenser—variable gang (with drum)
9	Condenser—315 Mmfd. 500 volt.
11	502159 Condenser—mica—50 Mmfd. 500 volt.
12	Condenser—1 Mfd. 200 volt.
13	502158 Condenser—2 Mfd. 400 volt.
14	502172 Condenser—trimmer: 25 to 100 Mmfd.
18	502262 Condenser—25 Mfd. 200 volt.
26	502470 Condenser—002 Mfd. 400 volt.
27	502453 Condenser—002 Mfd. 400 volt.
28	502160 Condenser—mica—110 Mmfd. 500 volt.
32	502160 Condenser—mica—110 Mmfd. 500 volt.
33	502153 Condenser—05 Mfd. 200 volt.
34	502156 Condenser—004 Mfd. 400 volt.
36	502151 Condenser—01 Mfd. 400 volt.
40A-40B	500256 Condenser—electrolytic { A-40 Mfd. 150 v. } B-20 Mfd. 150 v. }
43	502152 Condenser—02 Mfd. 400 volt.
46	502157 Condenser—05 Mfd. 400 volt.
RESISTORS	
6	502140 Resistor—carbon 390 ohms 1/4 watt
10	502130 Resistor—carbon 22,000 ohms 1/4 watt
15	502133 Resistor—carbon 220,000 ohms 1/4 watt
18	502281 Resistor—carbon 4700 ohms 1/4 watt
21	502268 Resistor—carbon 3.3 Meg. 1/4 watt
22	502264 Resistor—carbon 47 ohms 1/4 watt
24	502131 Resistor—carbon 47 ohms 1/4 watt
25A-25B	502145 Volume control 500,000 ohms (with switch)
28	502136 Resistor—carbon 10 Meg. 1/4 watt
30	502128 Resistor—carbon 2200 ohms 1/4 watt
31	502135 Resistor—carbon 2.2 Meg. 1/4 watt
35-36	502133 Resistor—carbon 220,000 ohms 1/4 watt
37	502134 Resistor—carbon 470,000 ohms 1/4 watt
38	502130 Resistor—carbon 130 ohms 1/4 watt
42	502468 Resistor—carbon 1500 ohms 1/4 watt
48	502574 Resistor—carbon 33 ohms 1/2 watt

*—Measured with vacuum tube voltmeter

DATA FOR STEWART-WARNER MODELS 9001-C, D, E, F

NOTE: A very small quantity of early production chassis utilized a circuit which differs from the one shown here. These differences may be summarized as follows:

- Terminal "D" of BC Antenna Coil No. 2 and terminal "P" of S.W. Antenna Coil No. 3 were connected to ground and not to A.V.C. as shown below.
 - Condenser No. 68 and resistor 69 were omitted.
 - Resistor No. 18 was rated at 680 ohms 1/4 watt.
- Improved sensitivity on Push-Button tuning and Short Wave operation may be obtained on these early production chassis by connecting coils No. 2 and No. 3 as shown in the circuit on this page and adding parts No. 68 and No. 69. Changing resistor No. 18 from 380 ohms to 220 ohms will improve sensitivity for Manual tuning on the Broadcast Band.

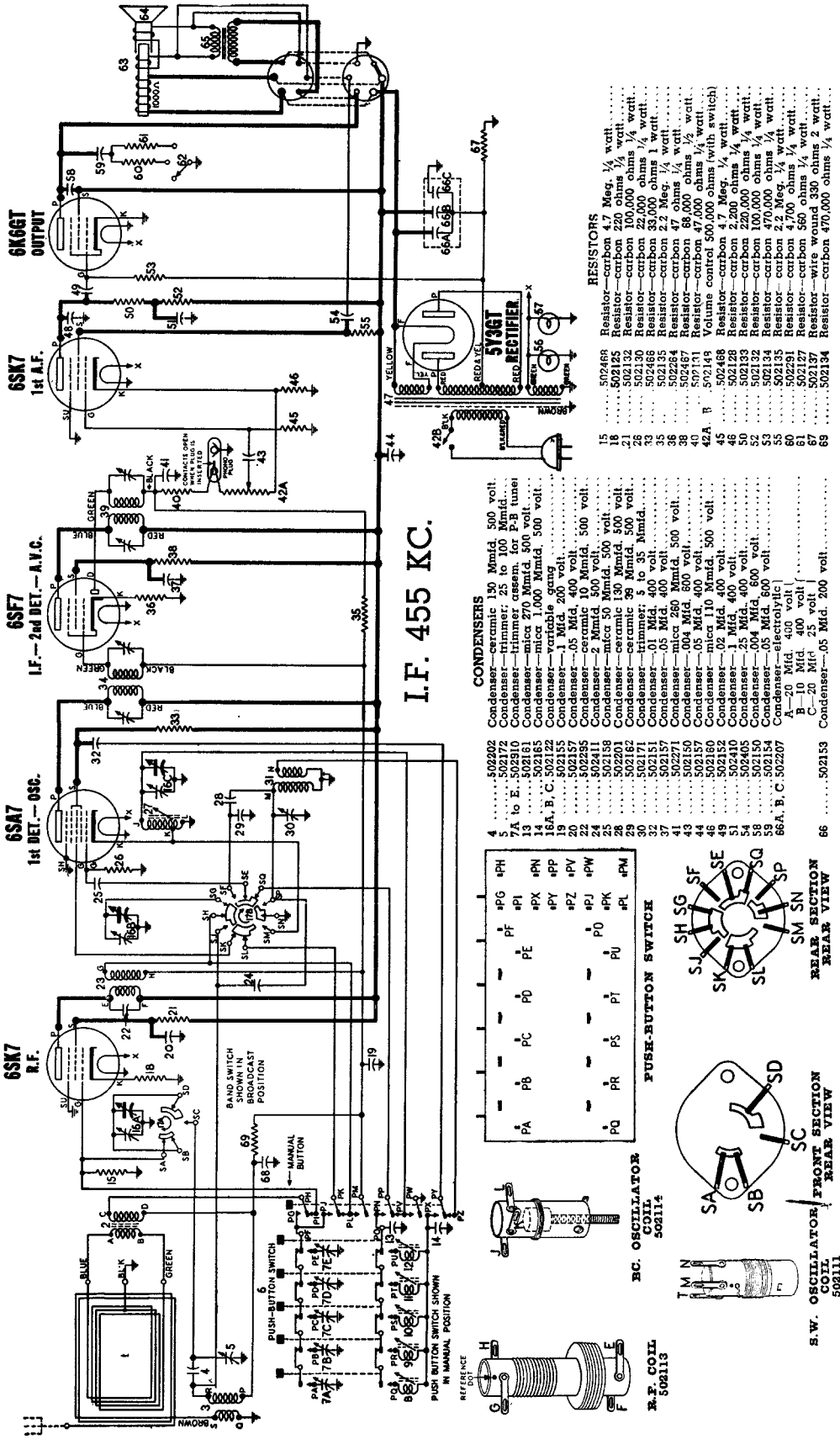

I.F. 455 KC.

CONDENSERS

- Condenser—ceramic 150 Mmfd. 500 volt.
- Condenser—trimmer. 25 to 100 Mmfd.
- Condenser—mica 270 Mmfd. 500 volt.
- Condenser—mica 1000 Mmfd. 500 volt.
- Condenser—mica 1000 Mmfd. 500 volt.
- Condenser—1 Mfd. 200 volt.
- Condenser—.05 Mfd. 400 volt.
- Condenser—.05 Mfd. 10 Mmfd. 500 volt.
- Condenser—.2 Mfd. 500 volt.
- Condenser—mica 30 Mmfd. 500 volt.
- Condenser—.01 Mfd. 600 volt.
- Condenser—ceramic 30 Mmfd. 500 volt.
- Condenser—trimmer. 5 to 35 Mmfd.
- Condenser—.01 Mfd. 400 volt.
- Condenser—.05 Mfd. 400 volt.
- Condenser—mica 280 Mmfd. 500 volt.
- Condenser—.04 Mfd. 600 volt.
- Condenser—.04 Mfd. 600 volt.
- Condenser—.02 Mfd. 500 volt.
- Condenser—.02 Mfd. 400 volt.
- Condenser—.1 Mfd. 400 volt.
- Condenser—.25 Mfd. 400 volt.
- Condenser—.04 Mfd. 600 volt.
- Condenser—.05 Mfd. 600 volt.
- Condenser—.05 Mfd. 600 volt.
- A—20 Mfd. 400 volt.
- B—10 Mfd. 400 volt.
- C—20 Mfd. 25 volt.
- Condenser—.05 Mfd. 200 volt.

RESISTORS

- 502469 Resistor—carbon 2.7 Meg. 1/4 watt.
- 502125 Resistor—carbon 100,000 ohms 1/4 watt.
- 502130 Resistor—carbon 22,000 ohms 1/4 watt.
- 502468 Resistor—carbon 33,000 ohms 1 watt.
- 502135 Resistor—carbon 47 ohms 1/4 watt.
- 502284 Resistor—carbon 68,000 ohms 1/4 watt.
- 502131 Resistor—carbon 100,000 ohms 1/4 watt.
- 502149 Resistor—carbon 470,000 ohms 1/4 watt.
- 502468 Resistor—carbon 4.7 Meg. 1/4 watt.
- 502128 Resistor—carbon 2,200 ohms 1/4 watt.
- 502133 Resistor—carbon 220,000 ohms 1/4 watt.
- 502132 Resistor—carbon 100,000 ohms 1/4 watt.
- 502134 Resistor—carbon 270,000 ohms 1/4 watt.
- 502131 Resistor—carbon 470,000 ohms 1/4 watt.
- 502127 Resistor—carbon 560 ohms 1/4 watt.
- 502137 Resistor—write wound 330 ohms 2 watt.
- 502134 Resistor—carbon 470,000 ohms 1/4 watt.

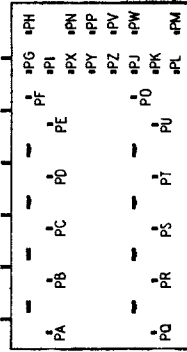

PUSH-BUTTON SWITCH

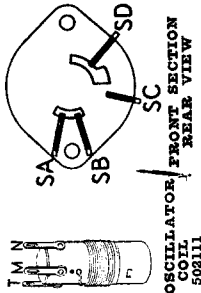

R.E. COIL 502113

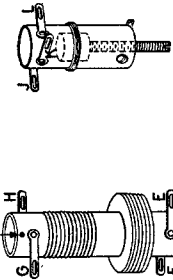

R.C. OSCILLATOR COIL 502115

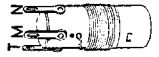

S.W. OSCILLATOR COIL 502111

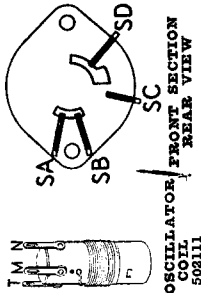

SC FRONT SECTION REAR VIEW

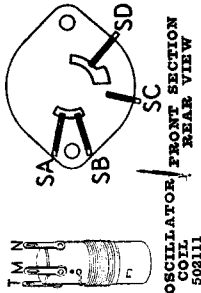

REAR SECTION REAR VIEW

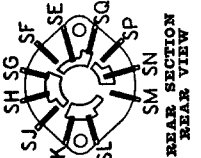

MANUAL OF 1947 MOST-OFTEN-NEEDED RADIO DIAGRAMS

STEWART-WARNER 9001-C, D, E, F

ALIGNMENT PROCEDURE

Remove chassis and loop antenna from cabinet (do not remove loop of wire stapled to cabinet). After chassis has been removed, replace loop antenna in cabinet. Stand the chassis on one end and space it approximately same distance from loop as when installed in cabinet. Then reconnect all leads to loop antenna and to loop of wire stapled on cabinet.

With the gang condenser fully meshed, dial pointer should be in the position indicated by the last division below 55 on the dial. If it is set incorrectly, release pointer clip on dial cord and reposition pointer.

Connect output meter across speaker voice coil or from plate of 6K6GT tube to chassis through a .1 Mfd. condenser.

Connect the ground lead of the signal generator to the receiver chassis.

Set volume control at maximum volume position and use a weak signal from the signal generator.

Push in the manual button and leave it in that position throughout the alignment procedure.

Align this receiver in exactly the order shown below. Broadcast band must be aligned before short wave band.

DUMMY ANT. IN SERIES WITH SIGNAL GENERATOR	CONNECT HIGH SIDE OF SIGNAL GENERATOR TO	SIGNAL GENERATOR FREQUENCY	BAND SWITCH POSITION	RECEIVER DIAL SETTING	TRIMMER NUMBER	TRIMMER DESCRIPTION	TYPE OF ADJUSTMENT
.1 MFD. Condenser	Trimmer on rear section of gang	455 KC	Broadcast (Clockwise)	Any point where it does not affect the signal.	1-2	2nd I.F.	Adjust for maximum output. Then repeat adjustment.
					3-4	1st I.F.	
500 MMFD. Mica Condenser	External Antenna Clip on Loop Frame	1500 KC	Broadcast (Clockwise)	1500 KC	5	Broadcast Oscillator (Shunt)	Adjust for maximum output.
500 MMFD. Mica Condenser	External Antenna Clip on Loop Frame	1500 KC	Broadcast (Clockwise)	Tune to 1500 Kc. generator signal.	6	Broadcast R.F.	Adjust for maximum output.
500 MMFD. Mica Condenser	External Antenna Clip on Loop Frame	1500 KC	Broadcast (Clockwise)	Tune to 1500 Kc. generator signal.	7	Broadcast Antenna	Adjust for maximum output.
500 MMFD. Mica Condenser	External Antenna Clip on Loop Frame	600 KC	Broadcast (Clockwise)	Tune to 600 Kc. generator signal.	8	Adjustable core of Broadcast Oscillator Coil.	Adjust for maximum output. Try to increase output by rotating core in and out and retuning receiver dial until maximum output is obtained.
500 MFD. Mica Condenser	External Antenna Clip on Loop Frame	Repeat adjustment of trimmers 5, 6 and 7 at 1500 Kc. Then re-check adjustment of trimmer 8 at 600 Kc.					
400 OHM Carbon Resistor	External Antenna Clip on Loop Frame	12 MC	Short wave (Counter-Clockwise)	12 MC	9	S.W. Oscillator	Adjust for maximum output. Check to see if proper peak was obtained by tuning in image at approx. 11.1 MC. If image does not appear, realign at 12 MC, with trimmer screw farther out. Recheck image.
400 OHM Carbon Resistor	External Antenna Clip on Loop Frame	12 MC	Short wave (Counter-Clockwise)	Tune to 12 MC. generator signal.	10	S.W. Antenna	Adjust for maximum output. Try to increase output by detuning trimmer and retuning receiver dial until maximum output is obtained.

TOP VIEW OF CHASSIS

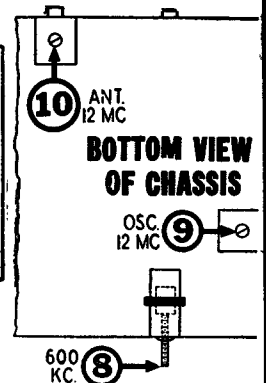
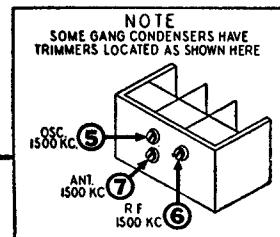
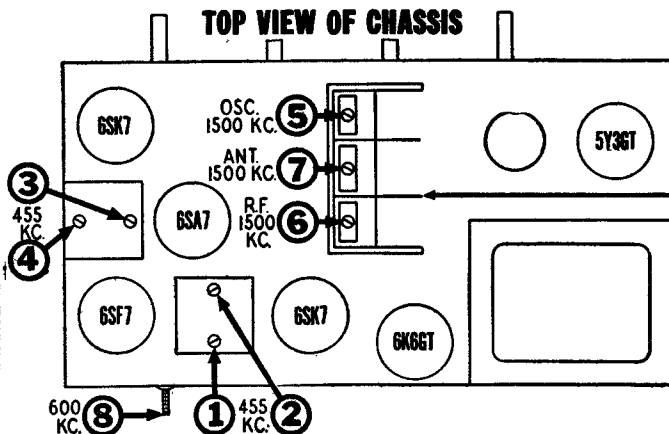

MANUAL OF 1947 MOST-OFTEN-NEEDED RADIO DIAGRAMS

STEWART-WARNER MODEL 9013-A

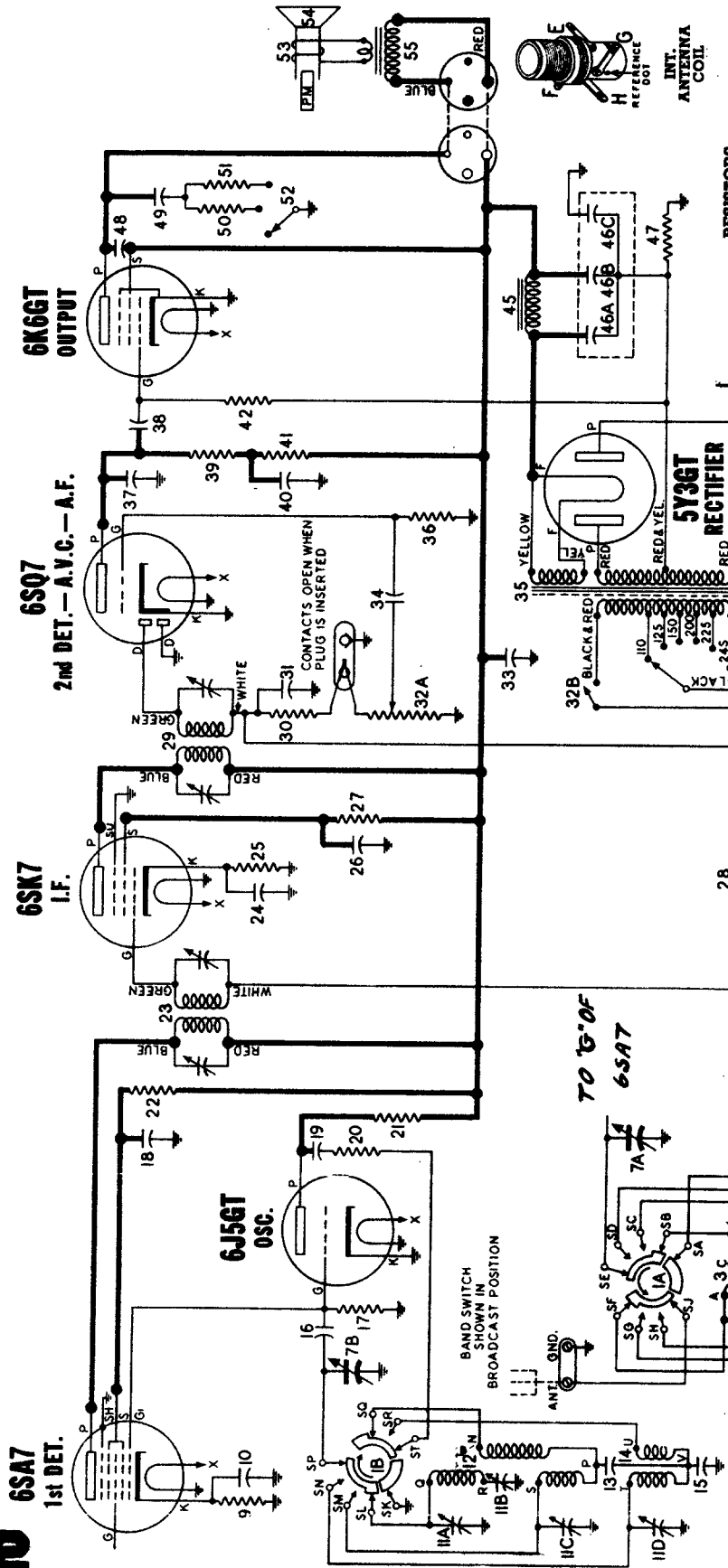

RESISTORS

9	Resistor—carbon 220 Ohms 1/4 watt
17	Resistor—carbon 22,000 Ohms 1/4 watt
20	Resistor—carbon 88 Ohms 1/4 watt
21	Resistor—carbon 22,000 Ohms 1/2 watt
22	Resistor—carbon 33,000 Ohms 1 watt
25	Resistor—carbon 220 Ohms 1/4 watt
27	Resistor—carbon 220 Ohms 1/4 watt
28	Resistor—carbon 2.2 Meg. 1/4 watt
30	Resistor—carbon 47,000 Ohms 1/4 watt
32A, B	Volume control 1 Meg. (with switch)
36	Resistor—carbon 10 Meg. 1/4 watt
39	Resistor—carbon 20 Meg. 1/4 watt
41	Resistor—carbon 100,000 Ohms 1/4 watt
42	Resistor—carbon 470,000 Ohms 1/4 watt
47	Resistor—wire wound 330 Ohms 2 watt
50	Resistor—carbon 4,700 Ohms 1/4 watt
51	Resistor—carbon 560 Ohms 1/4 watt

CONDENSERS

2	Condenser—mica 100 Mmfd
4A, B, C	Condenser—trimmer assembly
A	1-6 to 18 Mmfd.
B	1-6 to 18 Mmfd.
C	3 to 35 Mmfd.
7A, B	Condenser—variable gang
8	Condenser—.05 Mfd. 200 volt
10	Condenser—.05 Mfd. 200 volt
11	Condenser—trimmer assembly
A	3 to 35 Mmfd
B	300 to 600 Mmfd.
C	1-6 to 18 Mmfd.
D	1-6 to 18 Mmfd.
13	Condenser—mica 4,300 Mmfd.
15	Condenser—mica 47 Mmfd.
16	Condenser—.05 Mfd. 400 volt
18	Condenser—.01 Mfd. 400 volt
24	Condenser—.05 Mfd. 200 volt
26	Condenser—.05 Mfd. 400 volt
31	Condenser—mica 100 Mmfd.
33	Condenser—.1 Mfd. 600 volt
34	Condenser—.004 Mfd. 400 volt
37	Condenser—mica 200 Mmfd.
38	Condenser—.02 Mfd. 400 volt
40	Condenser—electrolytic
46A, B, C	Condenser—electrolytic
A	10 Mfd. 400 volt
B	10 Mfd. 400 volt
C	20 Mfd. 25 volt
48	Condenser—.004 Mfd. 400 volt
49	Condenser—.05 Mfd. 600 volt

TO 6SA7

2	502931
4A, B, C	504030
7A, B	504026
8	502806
10	502806
11	504031
13	504049
15	504049
16	502929
18	502807
18	502804

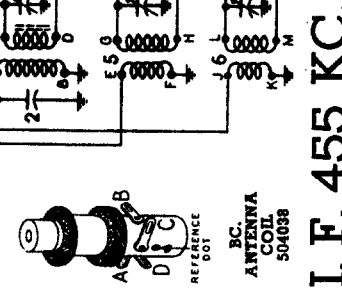

I. F. 455 KC.

MANUAL OF 1947 MOST-OFTEN-NEEDED RADIO DIAGRAMS

SERVICE DATA FOR MODEL 9013-A

ALIGNMENT PROCEDURE

When gang condenser is fully meshed, dial pointer should be in the position indicated by the last division below 55 on the dial. If it is set incorrectly, release pointer clip on dial cord and reposition pointer.

Connect on output meter across the speaker voice coil or from the plate of the 6K6GT tube to chassis through a 0.1 Mfd. condenser.

Connect the ground lead of the signal generator to the receiver chassis.

Set volume control to maximum volume position and use a weak signal from the signal generator.

DUMMY ANT. IN SERIES WITH SIGNAL GENERATOR	CONNECT HIGH SIDE OF SIGNAL GENERATOR TO	SIGNAL GENERATOR FREQUENCY	BAND SWITCH POSITION	RECEIVER DIAL SETTING	TRIMMER NUMBER	TRIMMER DESCRIPTION	TYPE OF ADJUSTMENT
1 MFD. Condenser	Lug on front section of gang.	455 KC	Broadcast (counter-clockwise)	Any point where it does not affect the signal.	1-2	2nd I.F.	Adjust for maximum output. Then repeat adjustment.
					3-4	1st I.F.	
200 MMFD. Mica Condenser	"ANT" terminal at rear of chassis.	1500 KC	Broadcast (counter-clockwise)	1500 Kc.	5	Broadcast Oscillator (Shunt)	Adjust for maximum output.
200 MMFD. Mica Condenser	"ANT" terminal at rear of chassis.	1500 KC	Broadcast (counter-clockwise)	Tune to 1500 Kc. generator signal.	6	Broadcast Antenna	Adjust for maximum output.
200 MMFD. Mica Condenser	"ANT" terminal at rear of chassis.	600 KC	Broadcast (counter-clockwise)	Tune to 600 Kc. generator signal.	7	Broadcast Oscillator (Series Pad)	Adjust for maximum output. Try to increase output by detuning trimmer and retuning receiver dial until maximum output is obtained.
400 OHM Carbon Resistor	"ANT" terminal at rear of chassis.	6.5 MC	Intermediate (middle)	6.5 Mc.	8	Intermediate Oscillator	Adjust to bring in signal. Check to see if proper peak was obtained by tuning in image at approx. 5.6 Mc. If image does not appear, realign at 6.5 Mc. with trimmer screw farther out. Recheck image.
400 OHM Carbon Resistor	"ANT" terminal at rear of chassis.	6.5 MC	Intermediate (middle)	Tune to 6.5 Mc. generator signal.	9	Intermediate Antenna	Adjust for maximum output. Try to increase output by detuning trimmer and retuning receiver dial until maximum output is obtained.
400 OHM Carbon Resistor	"ANT" terminal at rear of chassis.	21 MC	Short wave (clockwise)	21 Mc.	10	S.W. Oscillator	Adjust for maximum output. Check to see if proper peak was obtained by tuning in image at approx. 20.1 Mc. If image does not appear, realign at 21 Mc. with trimmer screw farther out. Recheck image.
400 OHM Carbon Resistor	"ANT" terminal at rear of chassis.	21 MC	Short wave (clockwise)	Tune to 21 Mc. generator signal.	11	S.W. Antenna	Adjust for maximum output. Try to increase output by detuning trimmer and retuning receiver dial until maximum output is obtained.

TOP VIEW OF CHASSIS

BOTTOM VIEW OF CHASSIS

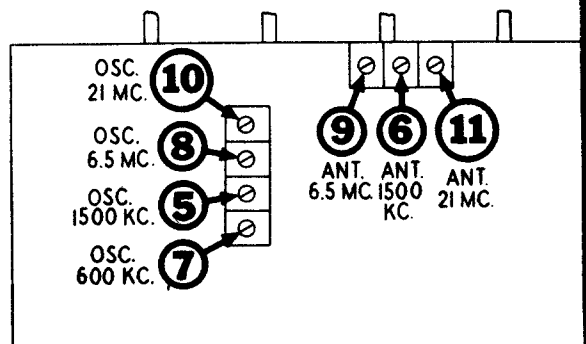
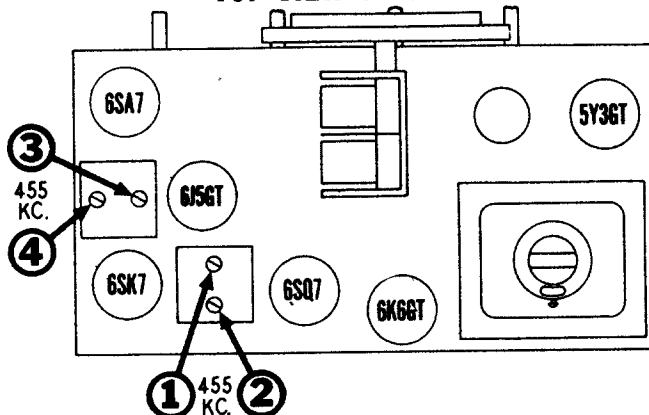

MANUAL OF 1947 MOST-OFTEN-NEEDED RADIO DIAGRAMS

STROMBERG-CARLSON RECEIVER NO. 1101

SERIES NOS. 10-11

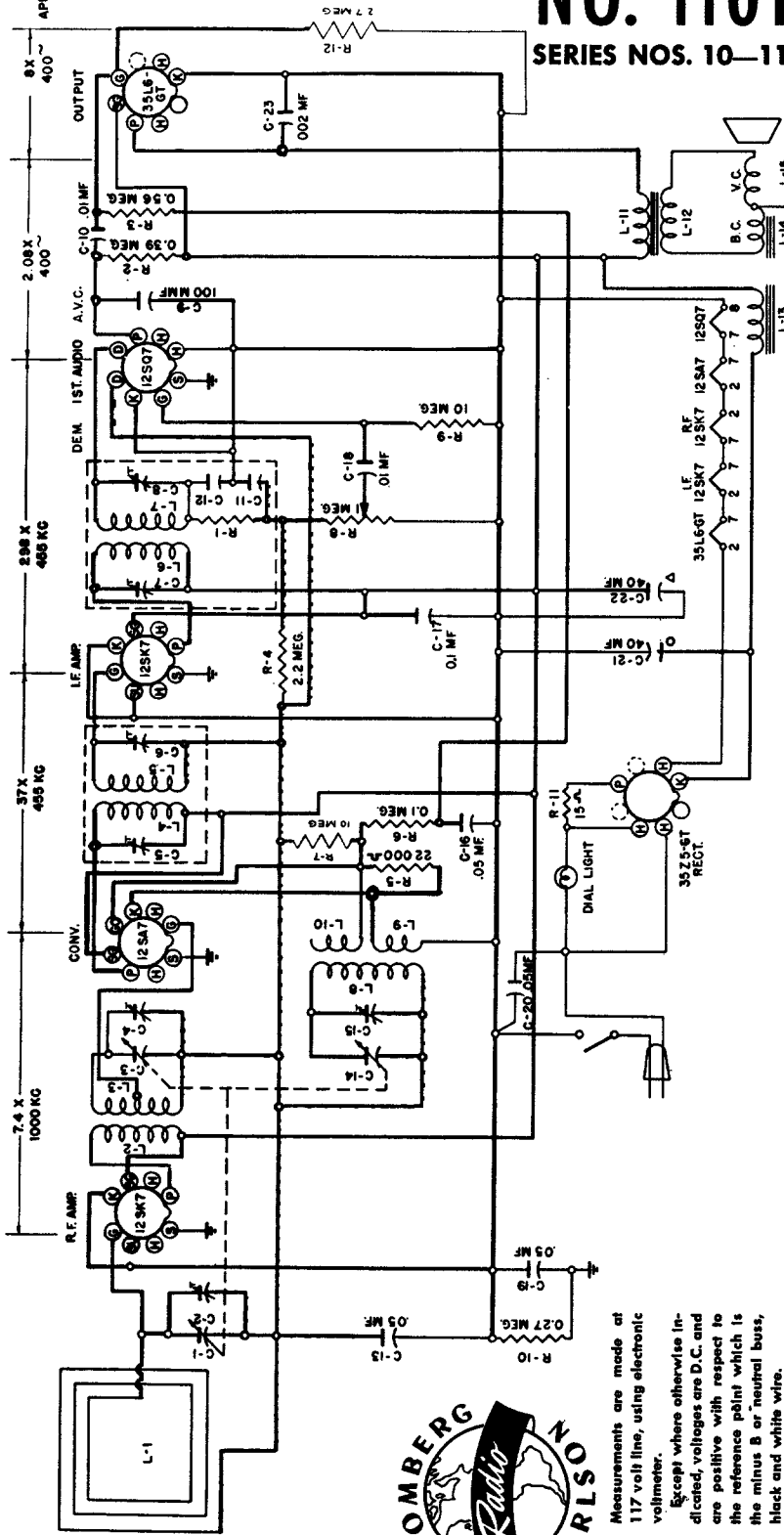

Measurements are made at 117 volt line, using electronic voltmeter. Except where otherwise indicated, voltages are D.C. and are positive with respect to the reference point which is the minus B or neutral buss, black and white wire.

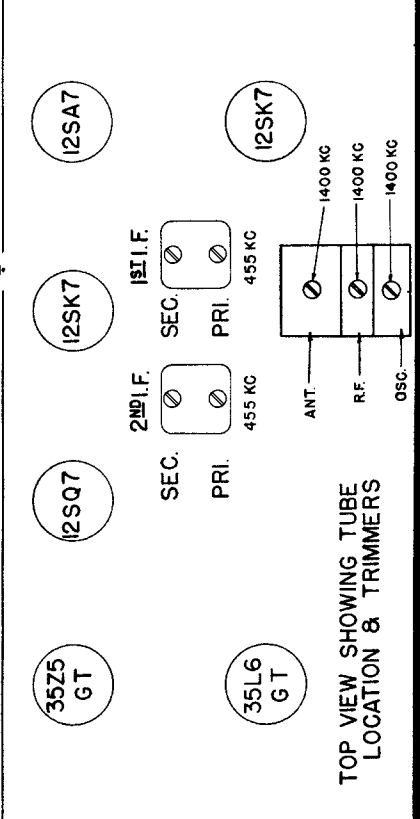

TOP VIEW SHOWING TUBE LOCATION & TRIMMERS

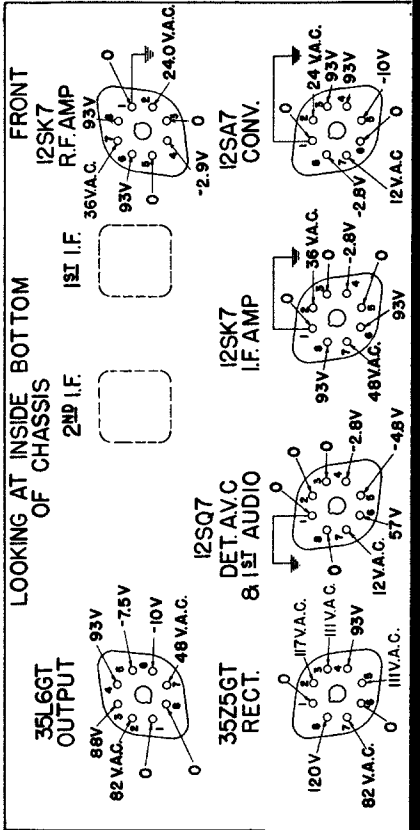

LOOKING AT INSIDE BOTTOM OF CHASSIS

FRONT



MANUAL OF 1947 MOST-OFTEN-NEEDED RADIO DIAGRAMS

STROMBERG-CARLSON CO., ROCHESTER 3, N. Y.
 Model No. 1101, Series Nos. 10-11

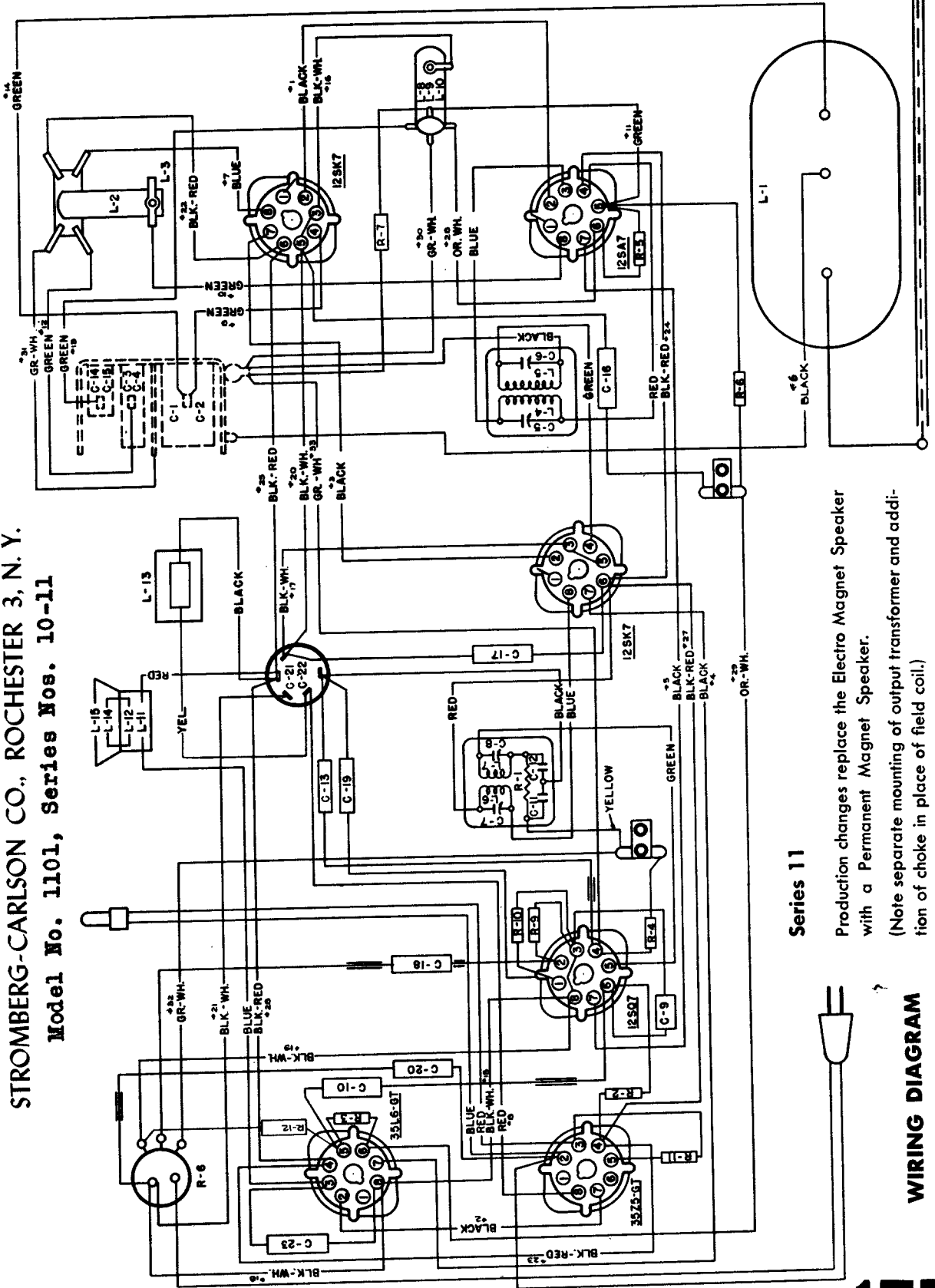

Series 11

Production changes replace the Electro Magnet Speaker with a Permanent Magnet Speaker.
 (Note separate mounting of output transformer and addition of choke in place of field coil.)



WIRING DIAGRAM

MANUAL OF 1947 MOST-OFTEN-NEEDED RADIO DIAGRAMS

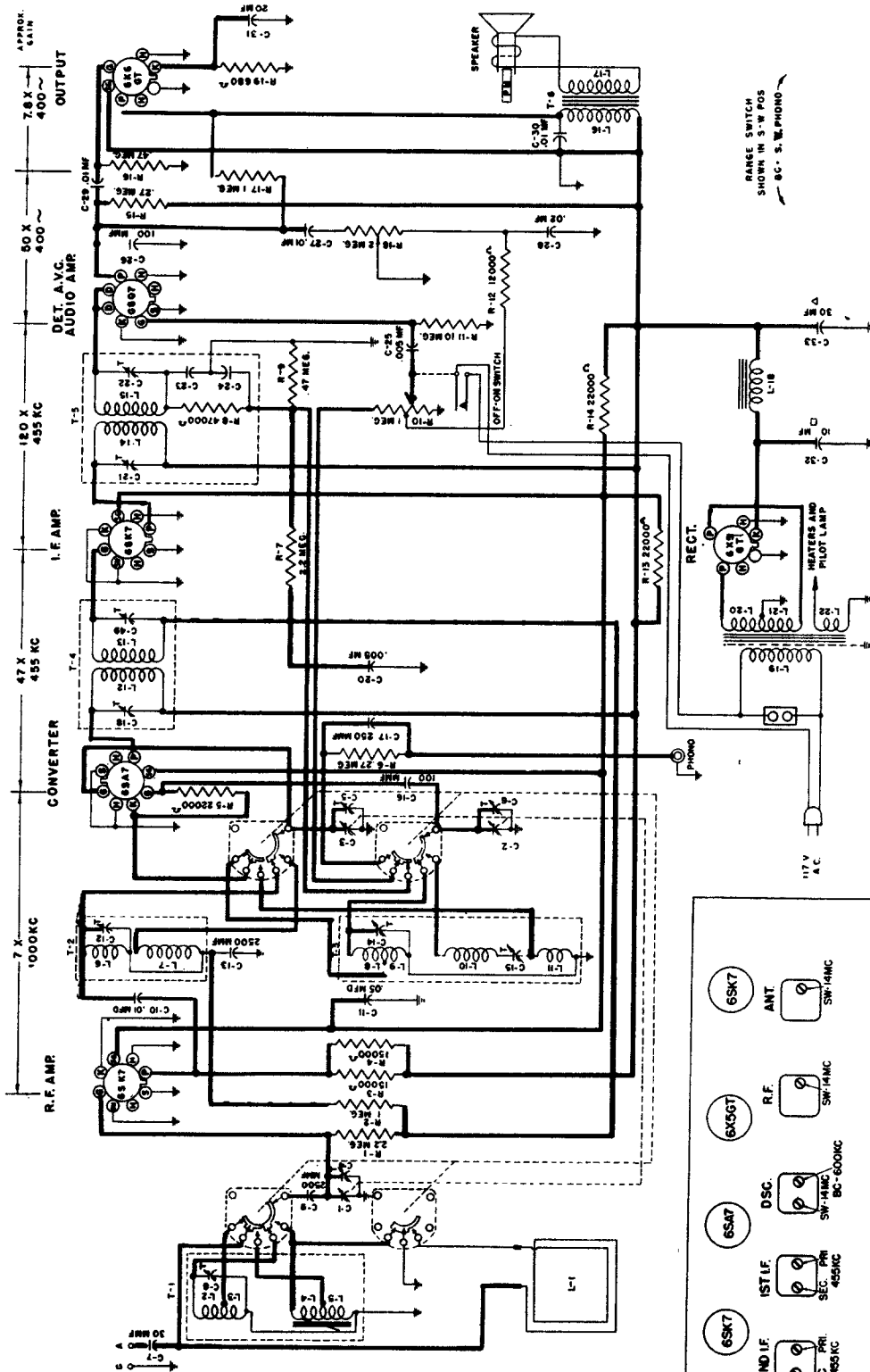

STROMBERG-CARLSON RADIO RECEIVER NO. 1110 SERIES NO. 10

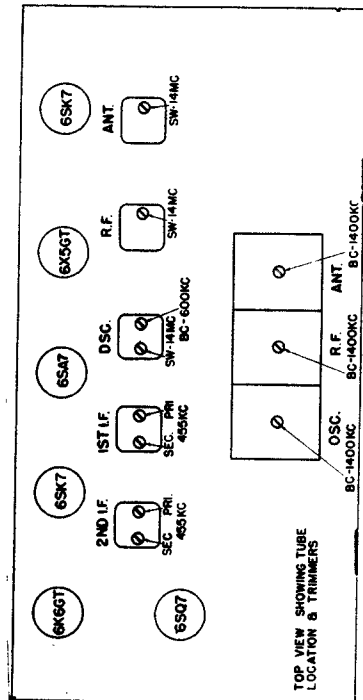

STROMBERG-CARLSON CO.

MANUAL OF 1947 MOST-OFTEN-NEEDED RADIO DIAGRAMS

STROMBERG-CARLSON CO.

Model 1110 * Series 10

ALIGNING

Never realign unless absolutely necessary.

Use a good signal generator modulated at 400 or 1,000 cycles, with variable output voltage and a sensitive output meter across the voice coil of the speaker.

Always align using the lowest possible input from the signal generator. A strong signal makes adjustments approximate.

Always have the volume control "full on."

Aligning Procedure (follow this order exactly)

Intermediate Frequency Adjustments.

1. Set range switch to Standard Broadcast Position.
2. Tune set to extreme high frequency end of dial.
3. Connect the ground terminal of the signal generator to the ground terminal of the chassis.
4. Introduce a modulated signal of 455 KC. to the grid of the 6SA7 Converter tube (middle section of gang condenser) using a 0.1 mfd. capacitor in series with the output lead of the signal generator.
5. Adjust the I.F. aligners for maximum output in the following order:
 - a. Secondary of second I.F. transformer.
 - b. Primary of second I.F. transformer.
 - c. Secondary of first I.F. transformer.
 - d. Primary of first I.F. transformer.

Dial Pointer Adjustment

With plates of the gang tuning capacitor fully engaged make certain that the dial pointer is in a horizontal position directly on the calibration marks located at the low frequency end of dial scale. Adjust the dial pointer if necessary.

Radio Frequency Adjustments

Standard Broadcast Range.

Antenna must remain connected for R.F. adjustments.

1. With the signal generator output lead connected to the Antenna and Ground terminal of the receiver, tune the signal generator frequency and receiver tuning dial to 1400 KC.
2. Adjust the oscillator, R.F. and antenna trimmers of the gang condenser for maximum signal.
3. Set the signal generator frequency and receiver tuning dial to 600 KC.
4. Adjust the 600 KC. padding condenser in oscillator coil shield for maximum signal.
5. Adjust the iron core in antenna transformer for maximum output. (Underside of chassis)
6. Repeat the above procedure until no further change is required.

Radio Frequency Adjustments

Short Wave Range

1. Set the range switch to Short Wave position.
2. Set the signal generator frequency and receiver tuning dial to 14 MC.
3. Connect the output of the signal generator to the antenna terminal on the chassis.
4. Adjust the oscillator, R.F. and antenna trimmers for maximum output.
5. Repeat the above procedure until no further change is required.

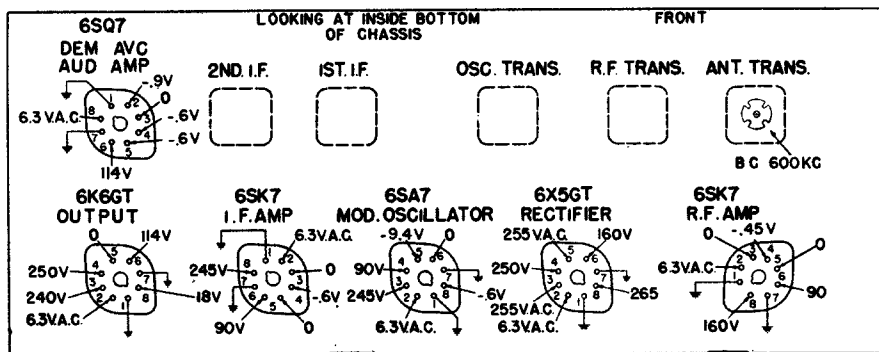

DIAL CORDING DIAGRAM

SPECIFICATIONS

Voltage Rating 105-125 Volts
 Type of Circuit Superheterodyne
 Tuning Range. . . S.W. 8.7—15.5 MC. Broadcast 540 KC.—1600 KC.
 Intermediate Frequency 455 KC.
 Speaker Voice Coil Impedance at 400 Cycles 3.5 Ohms
 Power Output 2 Watts

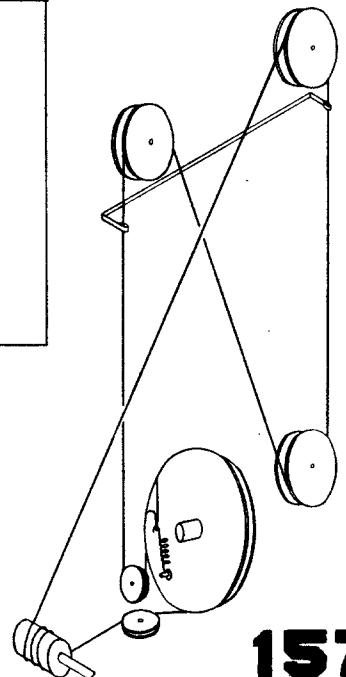
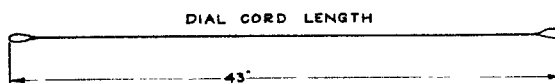

MANUAL OF 1947 MOST-OFTEN-NEEDED RADIO DIAGRAMS

STROMBERG-CARLSON

NO. 1121
SERIES NOS. 10-11-12

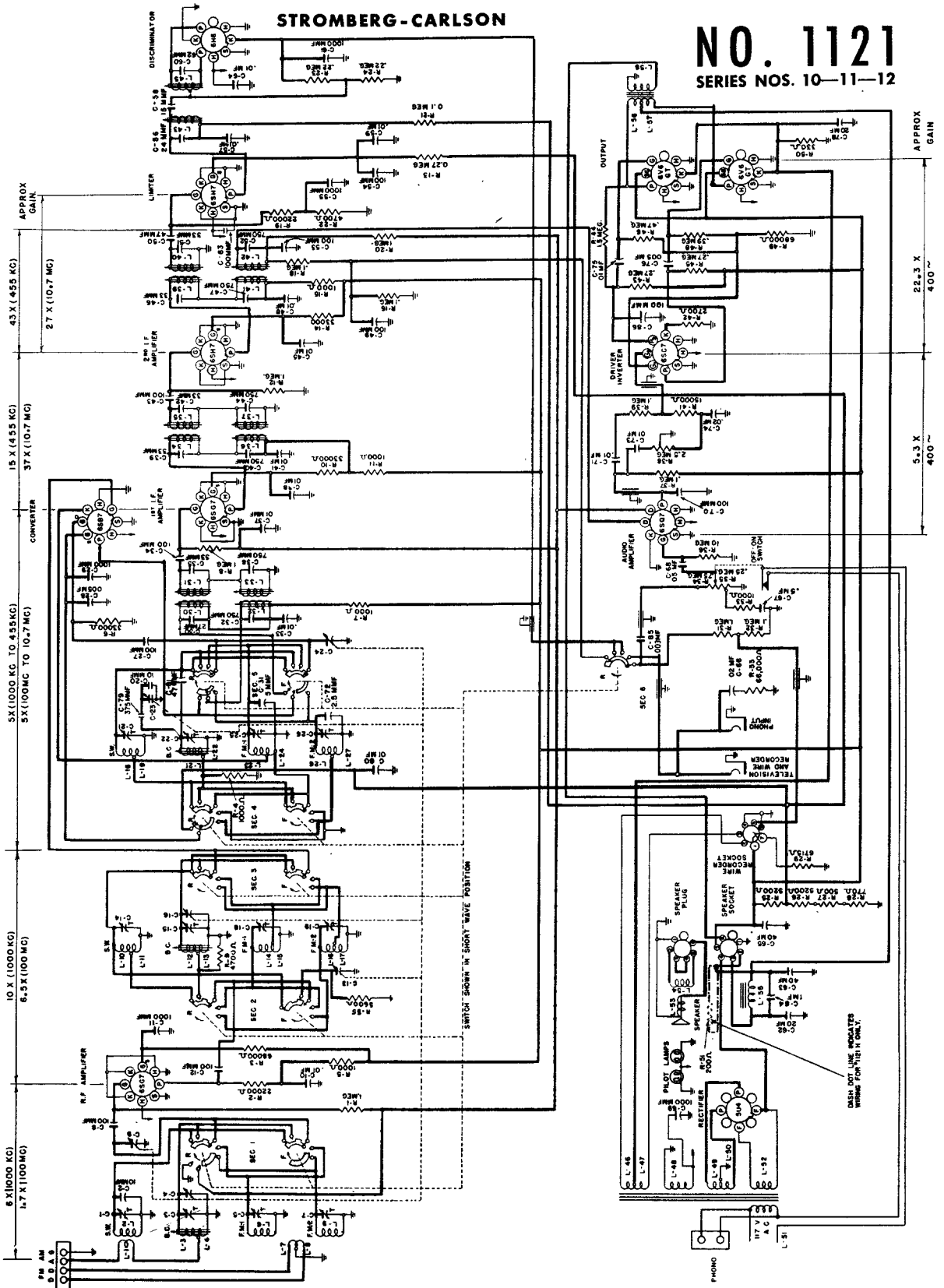

APPROX GAIN

43 X (455 KC)
27 X (10.7 MC)

15 X (455 KC)
37 X (10.7 MC)

5X (1000 KC TO 455 KC)
5X (100 MC TO 10.7 MC)

10 X (1000 KC)
6.5 X (100 MC)

6 X (1000 KC)
1.7 X (100 MC)

APPROX GAIN

22.3 X
400

5.3 X
400

MANUAL OF 1947 MOST-OFTEN-NEEDED RADIO DIAGRAMS

STROMBERG-CARLSON

Model 1121 (Continued)

Always align using the smallest possible input from the signal generator. A strong signal makes adjustments approximate.

Always have volume full on.

The required equipment is: 1 Electronic Voltmeter, 1 Output Meter, 1 Standard Signal Generator, 1 High Frequency Signal Generator, 1 No. 80777 Aligning Tool.

Aligning Procedure (follow this order exactly)

Intermediate Frequency Adjustments Amplitude Modulation

The I.F. aligners that are used to adjust the amplitude modulation (AM) channel are found on the top side of the chassis. They consist of 6 adjustable iron cores used to tune the inductance of the 1st, 2nd & 3rd I.F. transformers (161202, 161200, 161201). These cores are found inside the plastic tubes protruding from the top of the I.F. transformers and are equipped with small screwdriver slots.

1. Connect the signal generator to the modulator grid, terminal number 8 of the 6SB7 converter tube which is connected to the wave band switch, and is identified by a blue dot.
2. Connect the output meter across the voice coil of the speaker (green and black wires from cable).
3. Adjust the signal generator to 455 KC. Use 30% modulation at 400 cycles.
4. Adjust volume control full on.
5. Adjust tone control to maximum high (counter clockwise).
6. Adjust range switch to standard broadcast band, (second position clockwise.)
7. Adjust the tuning selector to approximately 600 KC.
8. Adjust I.F. cores for maximum output with a reduced signal input.

Frequency Modulation

The I.F. Aligners may be found from the underside of the chassis. The adjusters are 6 Iron cores used to tune the inductance of the high frequency coils.

1. Connect the signal generator to the modulator grid, terminal number 8 of the 6SB7 converter tube, which is connected to the wave band switch, and is identified by a blue dot.
2. Connect the electronic voltmeter to the junction of the 22,000 and the 4,700 ohm resistors in the limiter grid circuit, identified by a green dot.
3. Adjust the voltmeter to the lowest negative voltage scale.
4. Turn the range switch to the 2nd F.M. band (fourth position clockwise).
5. Adjust the tuning selector to approximately 21 on this band.
6. Adjust the signal generator to 10.7 megacycles. No modulation is required.
7. Adjust the cores for maximum output of the voltmeter. Reduce the input signal and readjust until the maximum output is secured for minimum input.

Discriminator Alignment (FM)

1. Connect the signal generator to the grid of the second I.F. tube, terminal No. 4 of the 6SH7.
2. Connect the electronic voltmeter to the center of the diode load resistors at the point indicated by the orange dot.
3. Adjust the primary for maximum output with the signal generator set at 10.7 megacycles.
4. Switch the electronic voltmeter to the high side of the diode load resistors, identified by a red dot.
5. Adjust the secondary for zero output.
6. Swing generator to 75 KC higher and 75 KC lower in frequency and note the plus and minus voltage. If these voltage values are not approximately equal, repeat operations 3, 4 and 5.

Dial Pointer Adjustment

Check dial pointer to see that it is aligned through the center of the 2 in the number 201 of FM Band (1) when the variable capacitor plates are completely engaged.

R.F. Adjustment — Amplitude Modulation

The Broadcast band should be adjusted first.

The built-in loop should remain connected to the antenna and ground terminals.

1. Connect the signal generator to the antenna terminal, using a 200 mmf. capacitor. Use 30% modulation at 400 cycles.
2. Adjust the signal generator to 1500 KC.
3. Adjust station selector to 1500 KC.
4. Adjust range switch to AM Broadcast. (Second position clockwise.)
5. Adjust the oscillator, R.F. and antenna trimmer for maximum output.
6. Reduce the input signal and readjust the trimmers until the maximum output is secured for minimum input.
7. Adjust station selector to 600 KC.
8. Set signal generator to 600 KC.
9. Adjust iron cores in oscillator, R.F. and antenna coils for maximum output.
10. Repeat 1500 KC and 600 KC alignments until no further change is required.

R.F. Adjustment — Short Wave

The built-in loop should remain connected to the antenna and ground terminals.

1. Connect the signal generator to the antenna and ground terminals of the receiver using a 400 ohm resistor.
2. Set the dial pointer to 9.5 megacycles.
3. Adjust signal generator to 9.5 megacycles.
4. Adjust range switch to Short Wave (first position clockwise).
5. Adjust oscillator, R.F., and antenna trimmer for maximum output. (No further alignment is required on this band.)

MANUAL OF 1947 MOST-OFTEN-NEEDED RADIO DIAGRAMS

**Stromberg
Carlson
Model 1121**

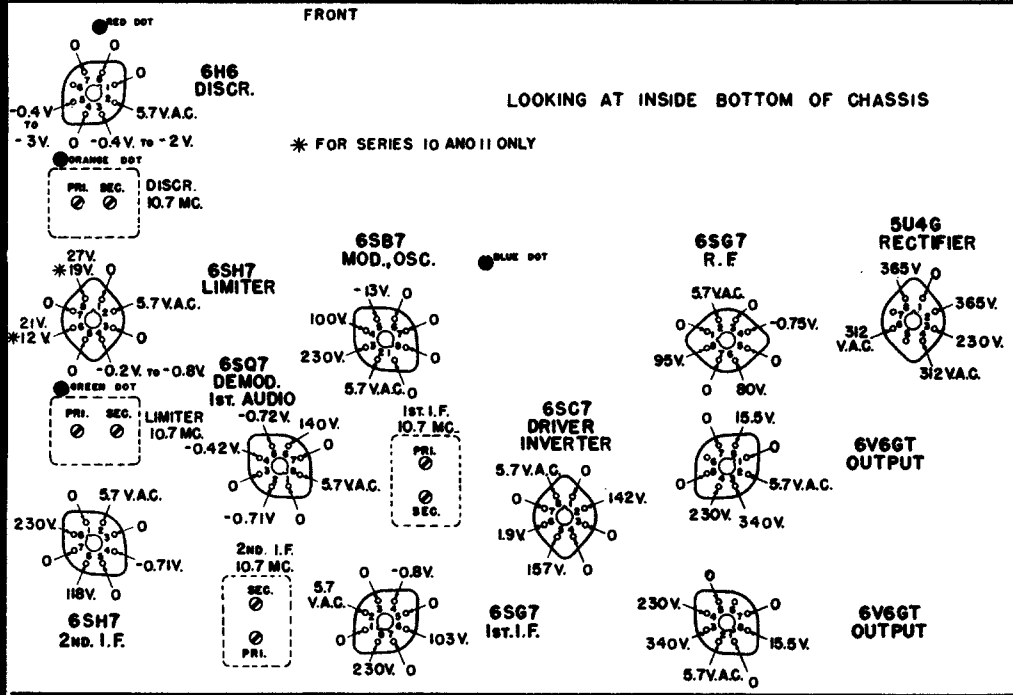

R.F. Adjustments — Frequency Modulation

Align the FM (2) Band first.

1. Set the dial pointer to 61.
2. Connect the signal generator to FM dipole terminals using 39 ohm resistors as indicated. (Disconnect dipole antenna.) Connect Signal Generator ground to chassis ground.
3. Set signal generator to 46.1 megacycles.

4. Adjust range switch to FM (2) (fourth position clockwise).
5. Connect the electronic voltmeter to the junction of the 22,000 and 4,700 ohm resistors in the limiter grid circuit. (Identified by green dot.)
6. Adjust oscillator R.F. and antenna trimmers for maximum output on electronic voltmeter.

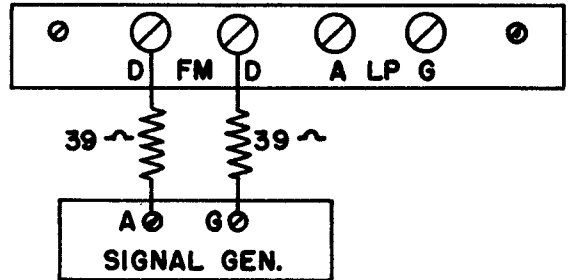
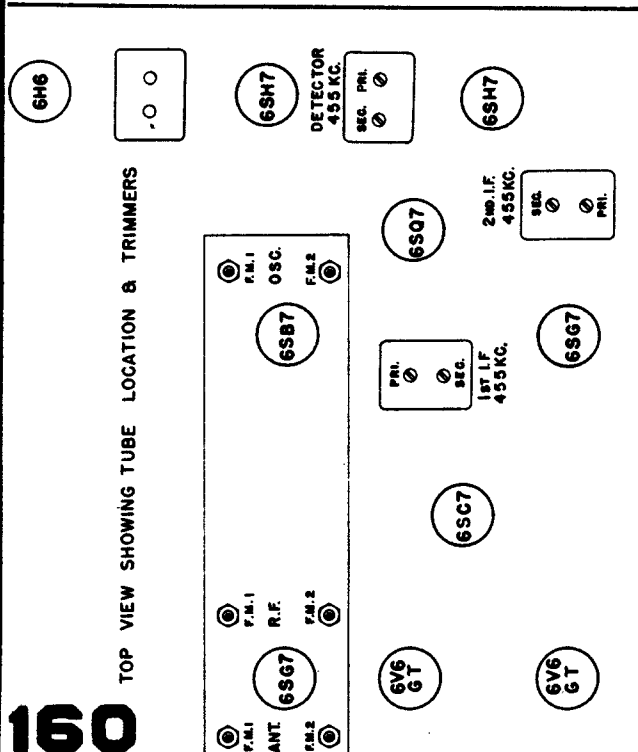

FM (1) Band

Adjust the same as the FM (2) band using 100.1 megacycles, setting the dial pointer to 261. Connect the generator to the dipole input using 39 ohm resistors as indicated. Connect Signal Generator ground to chassis ground. Note reversed Signal Generator connection.

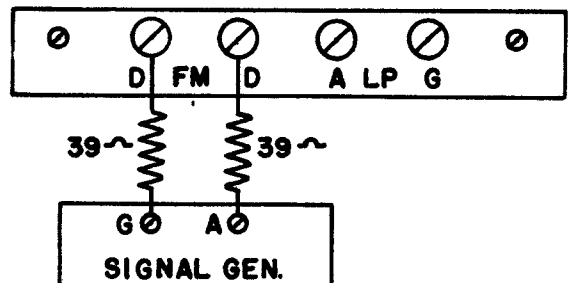

MANUAL OF 1947 MOST-OFTEN-NEEDED RADIO DIAGRAMS

STROMBERG-CARLSON

**Stromberg-Carlson
Model 1121**

FRONT VIEW OF CHASSIS

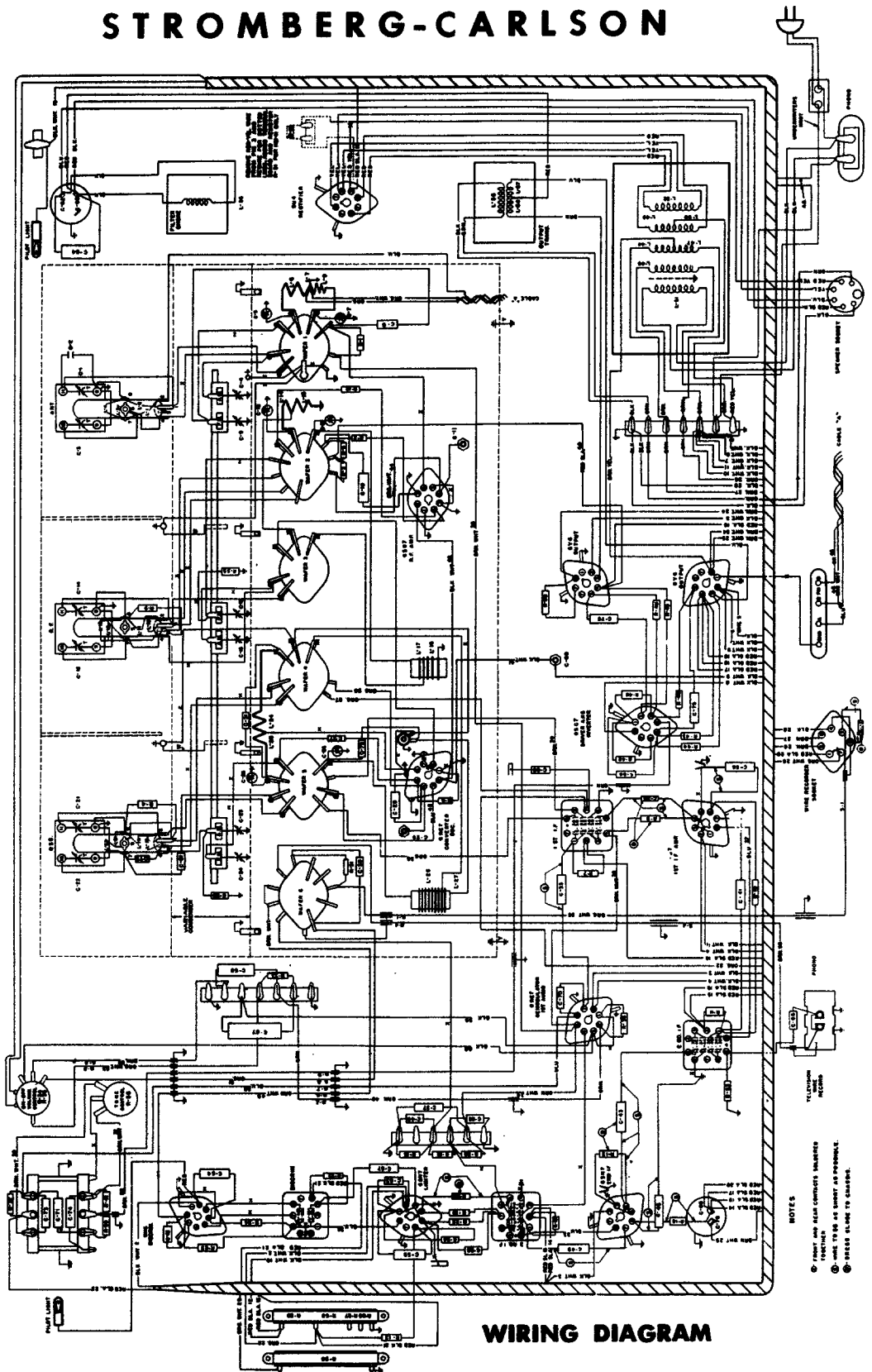

WIRING DIAGRAM

NOTES
 1. FRONT AND REAR CONNECTOR INDICATES FUNCTION.
 2. WIRE TO BE AS SHOWN AS POSSIBLE.
 3. WIRE TO BE AS SHOWN AS POSSIBLE.
 4. WIRE TO BE AS SHOWN AS POSSIBLE.

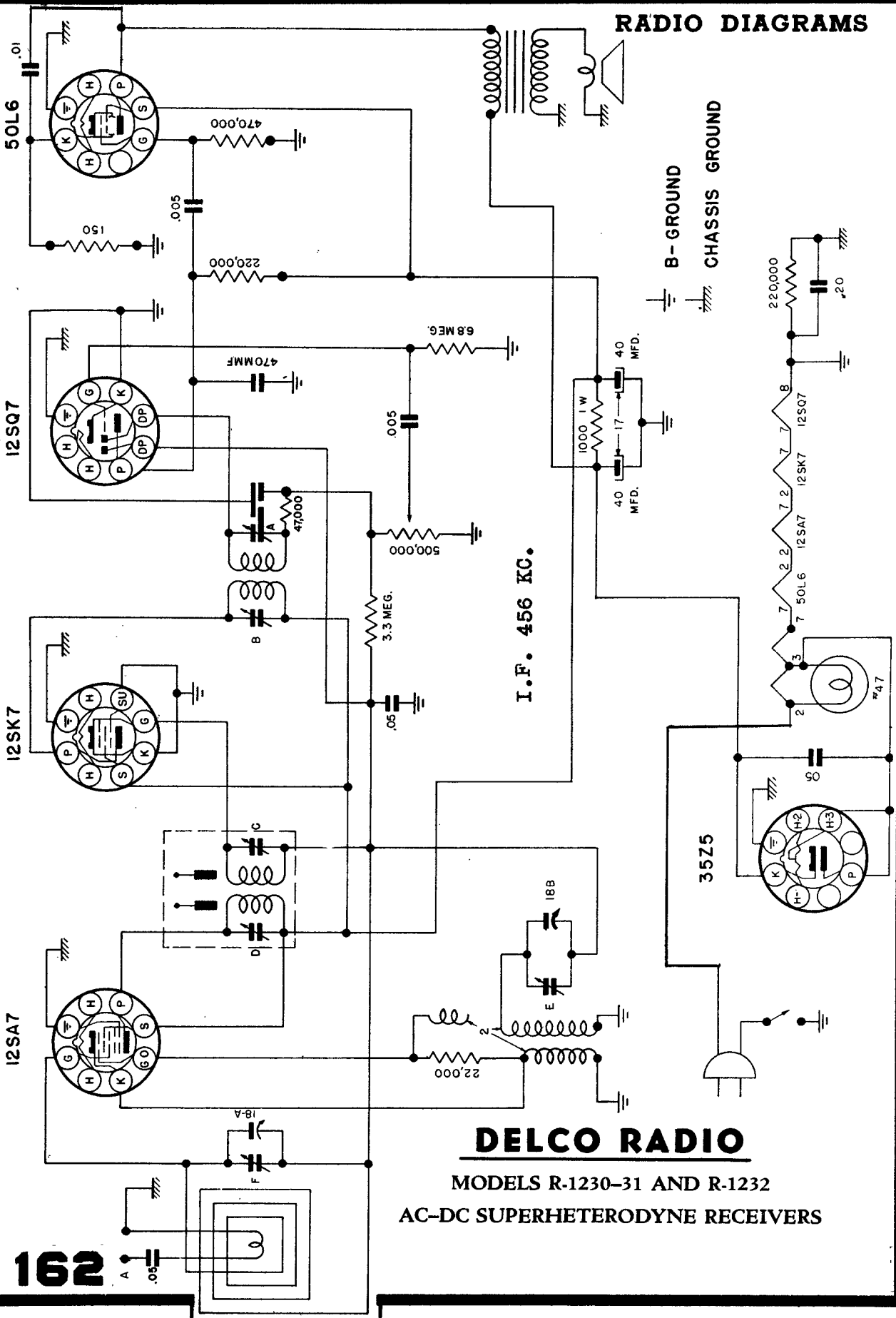

I.F. 456 KC.

B-GROUND
CHASSIS GROUND

DELCO RADIO

MODELS R-1230-31 AND R-1232

AC-DC SUPERHETERODYNE RECEIVERS

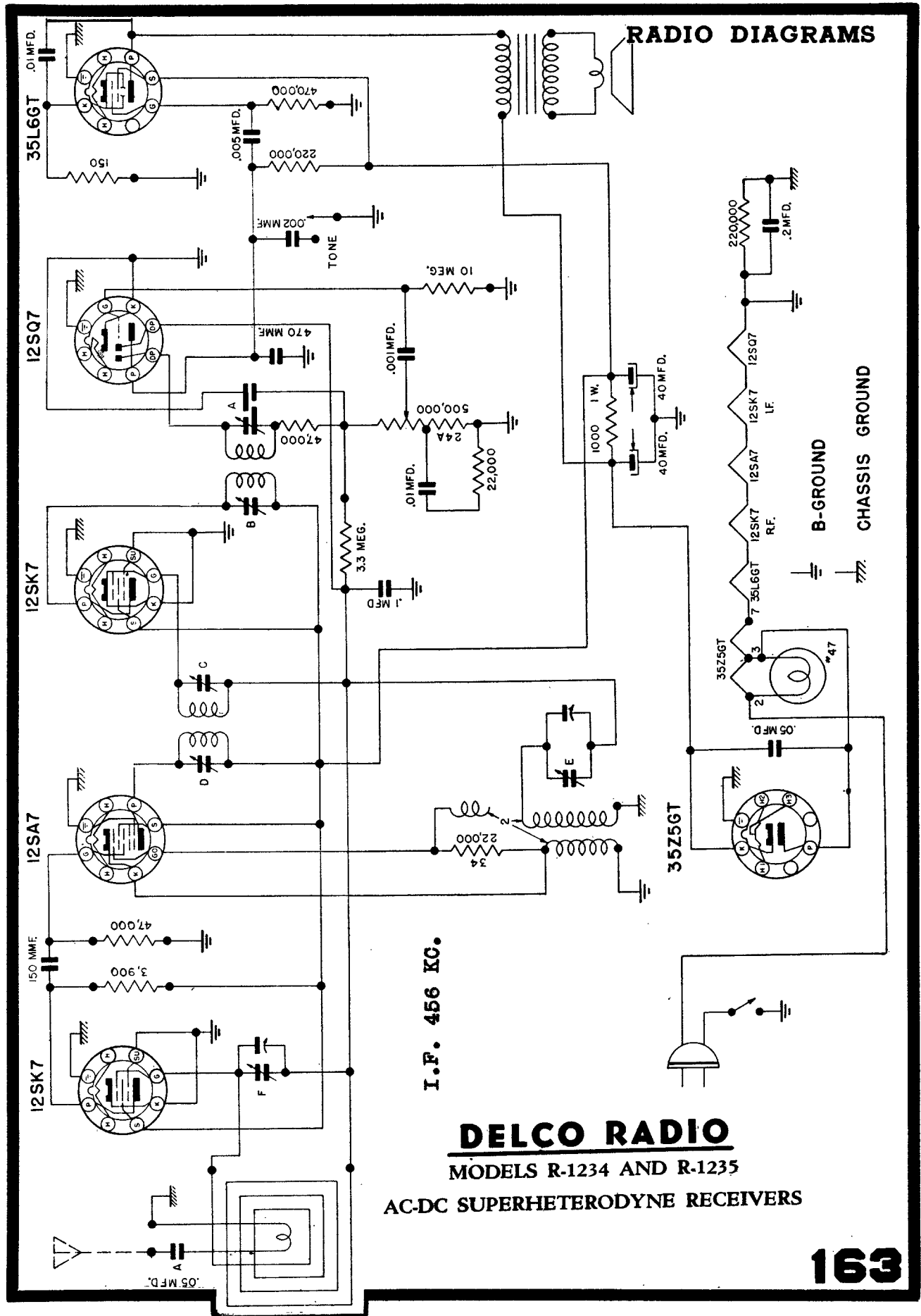

I.F. 456 KC.

DELCO RADIO
MODELS R-1234 AND R-1235
AC-DC SUPERHETERODYNE RECEIVERS

MANUAL OF 1947 MOST-OFTEN-NEEDED RADIO DIAGRAMS

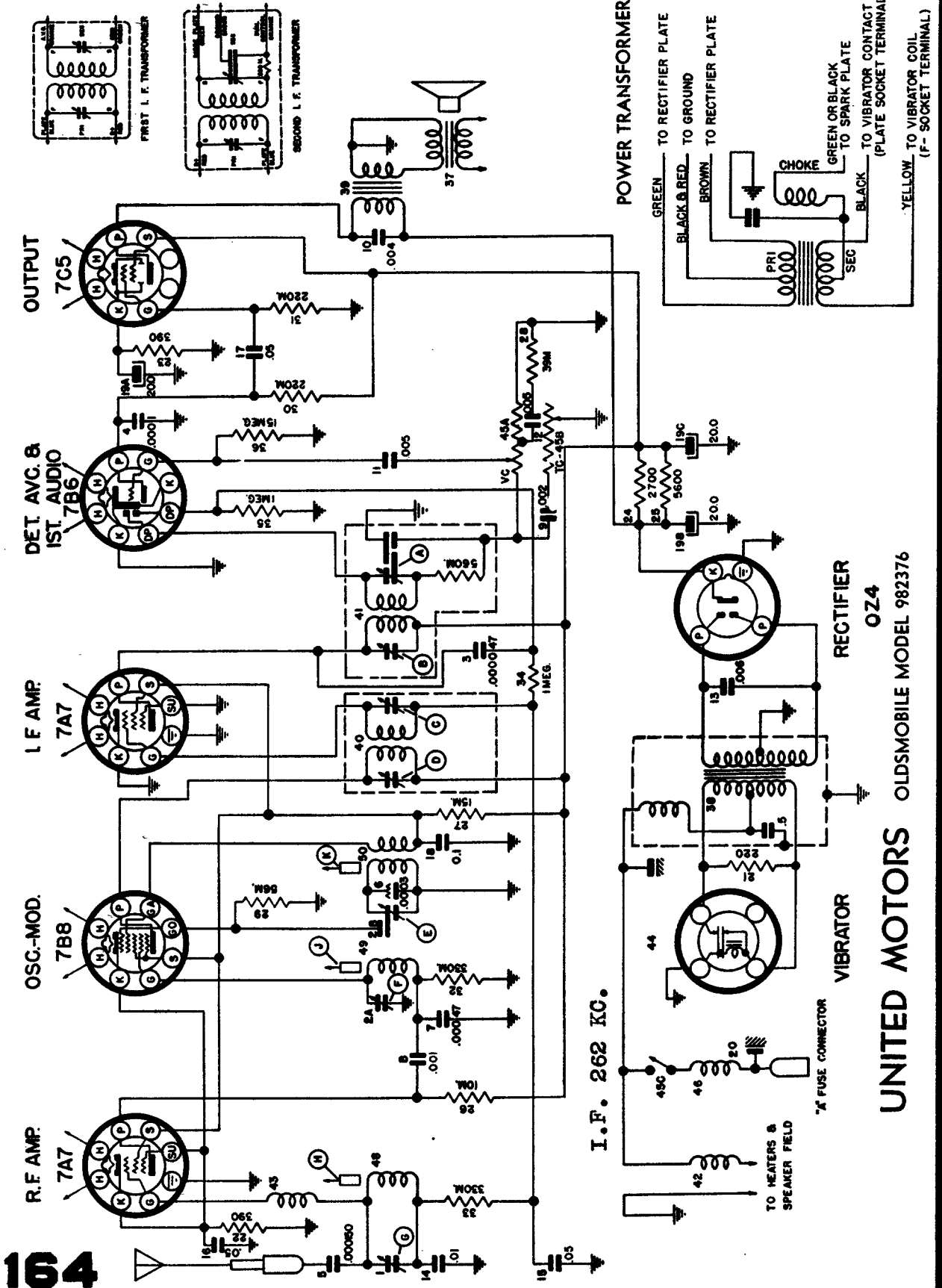

UNITED MOTORS OLDSMOBILE MODEL 982376

MANUAL OF 1947 MOST-OFTEN-NEEDED RADIO DIAGRAMS

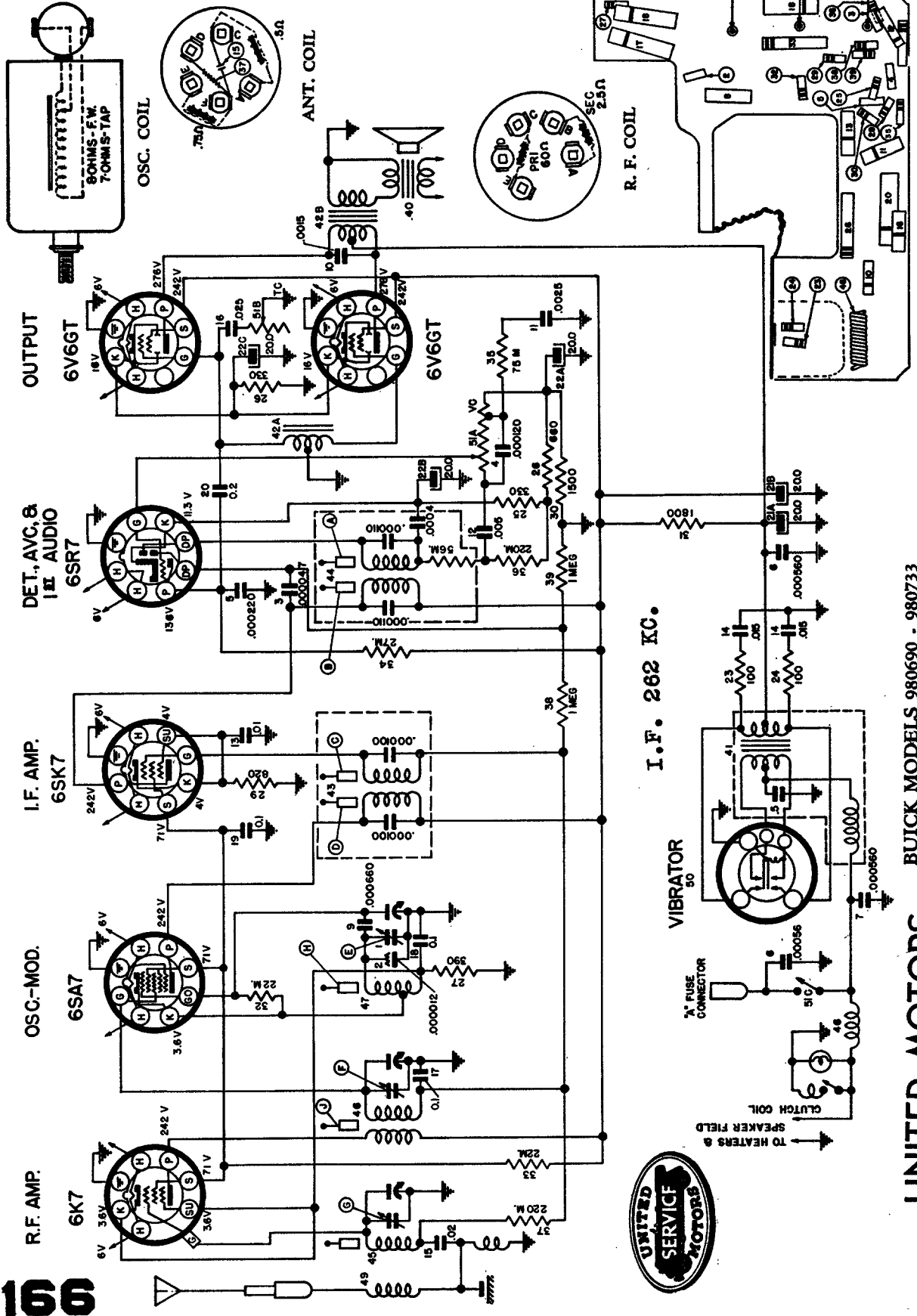

PARTS LAYOUT - CHASSIS VIEW

BUICK MODELS 980690 - 980733

UNITED MOTORS



MANUAL OF 1947 MOST-OFTEN-NEEDED RADIO DIAGRAMS

UNITED MOTORS

Pontiac 1946 Model 984172

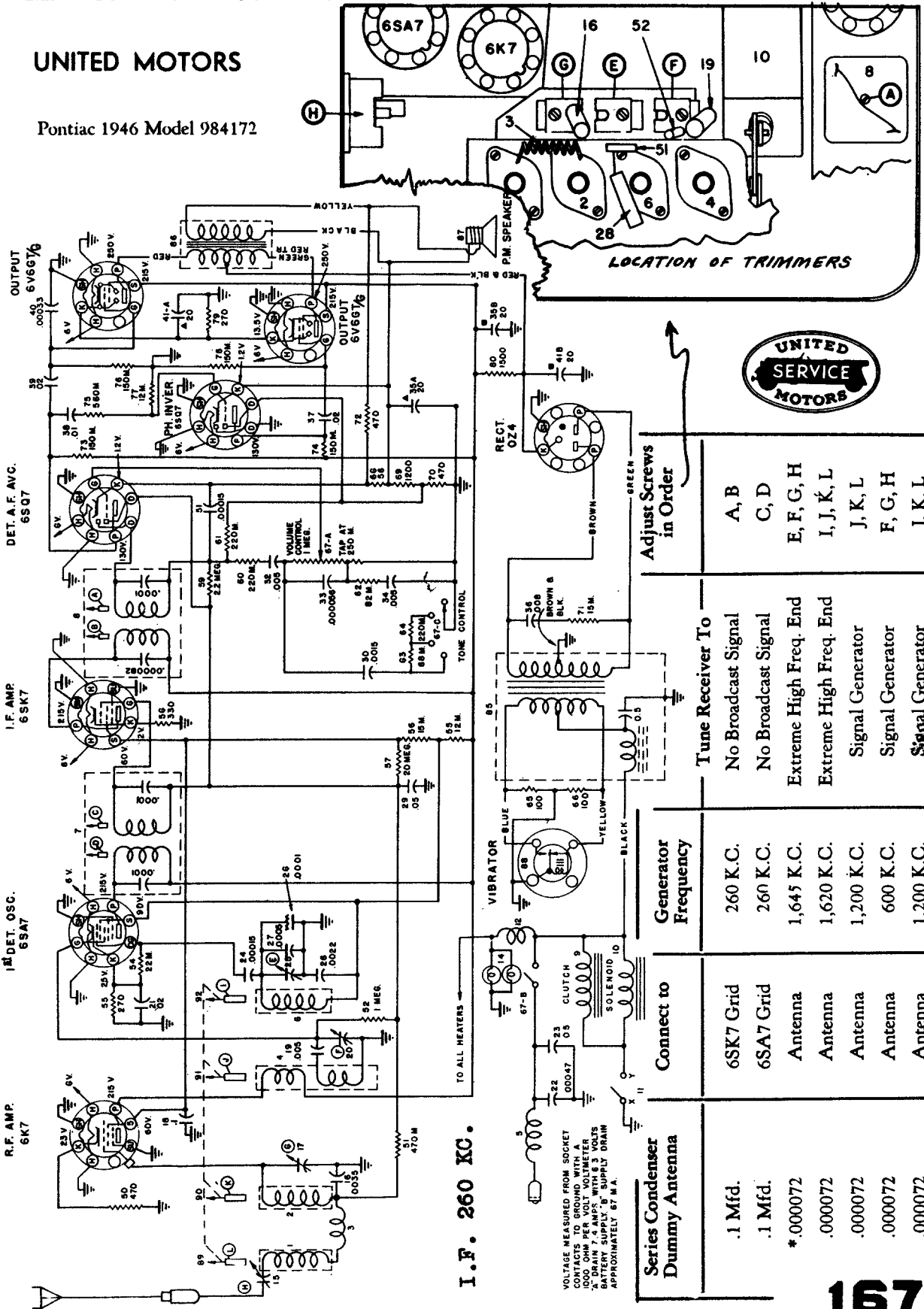

Series Condenser Dummy Antenna	Connect to	Generator Frequency	Tune Receiver To	Adjust Screws in Order
.1 Mfd.	6SK7 Grid	260 K.C.	No Broadcast Signal	A, B
.1 Mfd.	6SA7 Grid	260 K.C.	No Broadcast Signal	C, D
*.000072	Antenna	1,645 K.C.	Extreme High Freq. End	E, F, G, H
.000072	Antenna	1,620 K.C.	Extreme High Freq. End	I, J, K, L
.000072	Antenna	1,200 K.C.	Signal Generator	J, K, L
.000072	Antenna	600 K.C.	Signal Generator	F, G, H
.000072	Antenna	1,200 K.C.	Signal Generator	J, K, L

I.F. 260 KC.

VOLTAGE MEASURED FROM SOCKET CONTACTS TO GROUND WITH A 1000 OHM PER VOLT VOLTMETER * DRAIN 7-8 AMPS. WITH 6.3 VOLTS BATTERY SUPPLY. B. SUPPLY DRAIN APPROXIMATELY 67 M.A.

MANUAL OF 1947 MOST-OFTEN-NEEDED RADIO DIAGRAMS

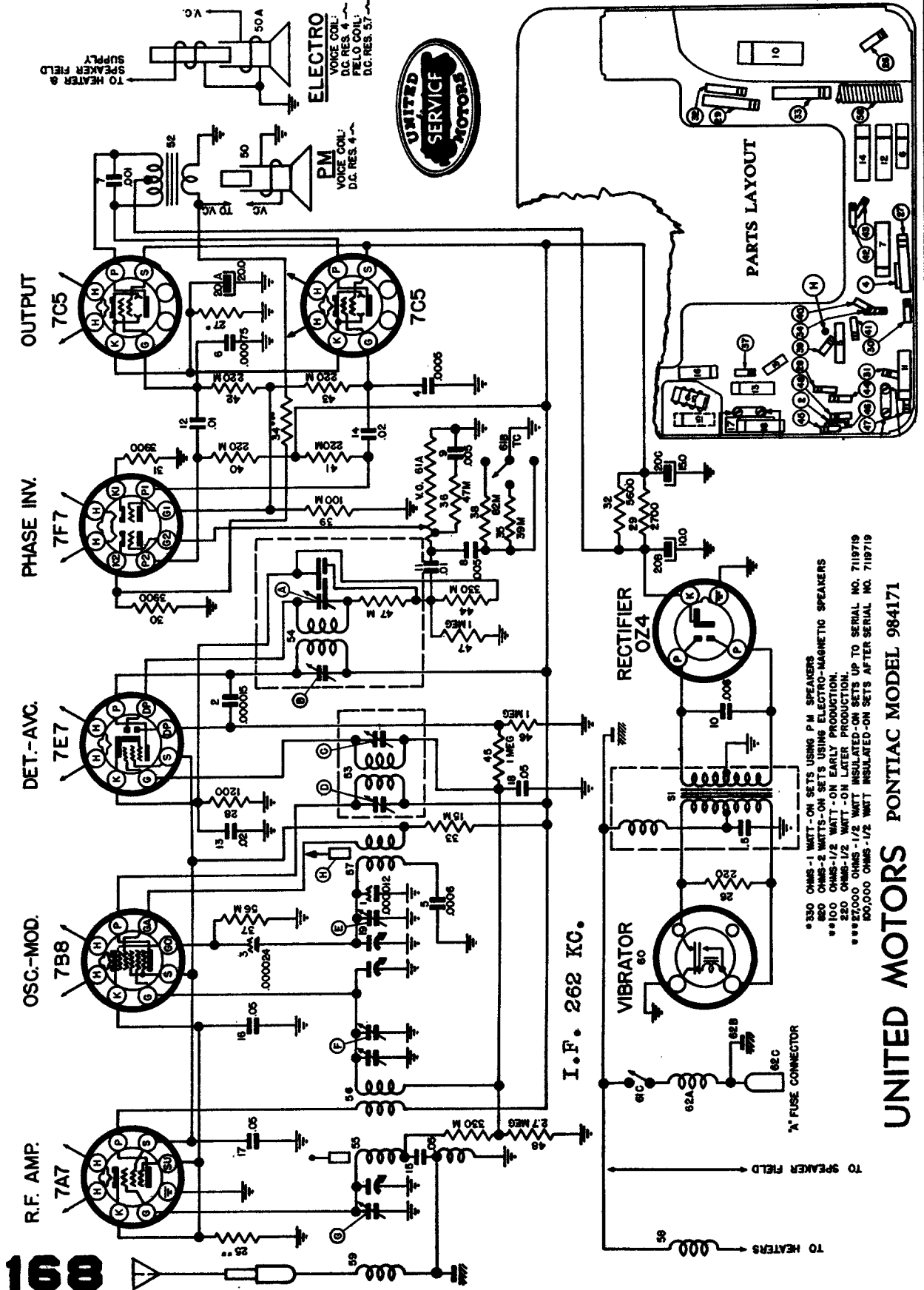

- **330 OHMS - 1 WATT - ON SETS USING P.M. SPEAKERS
- **800 OHMS - 2 WATTS - ON SETS USING ELECTRO-MAGNETIC SPEAKERS
- **100 OHMS - 1/2 WATT - ON EARLY PRODUCTION.
- **220 OHMS - 1/2 WATT - ON LATER PRODUCTION.
- ***27,000 OHMS - 1/2 WATT INSULATED-ON SETS UP TO SERIAL NO. 7119719
- ***50,000 OHMS - 1/2 WATT INSULATED-ON SETS AFTER SERIAL NO. 7119719

MANUAL OF 1947 MOST-OFTEN-NEEDED RADIO DIAGRAMS

BLUE TO 6V6 PLATE
GREEN TO VOICE COIL

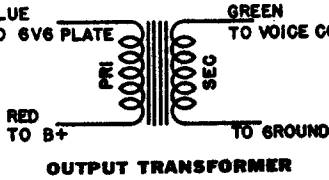

OUTPUT
6V6GT

DET., AVC., &
1ST. AUDIO AMP.
6SQ7

I.F. AMP.
6SK7

OSC.-MOD.
6SA7

R.F. AMP.
6SK7

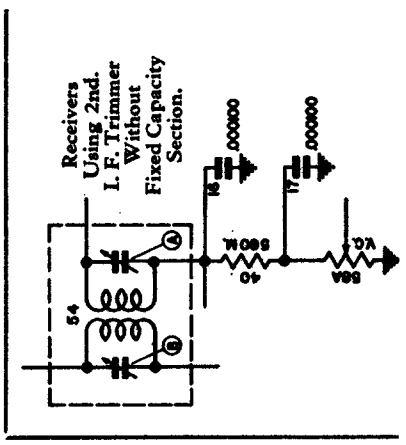
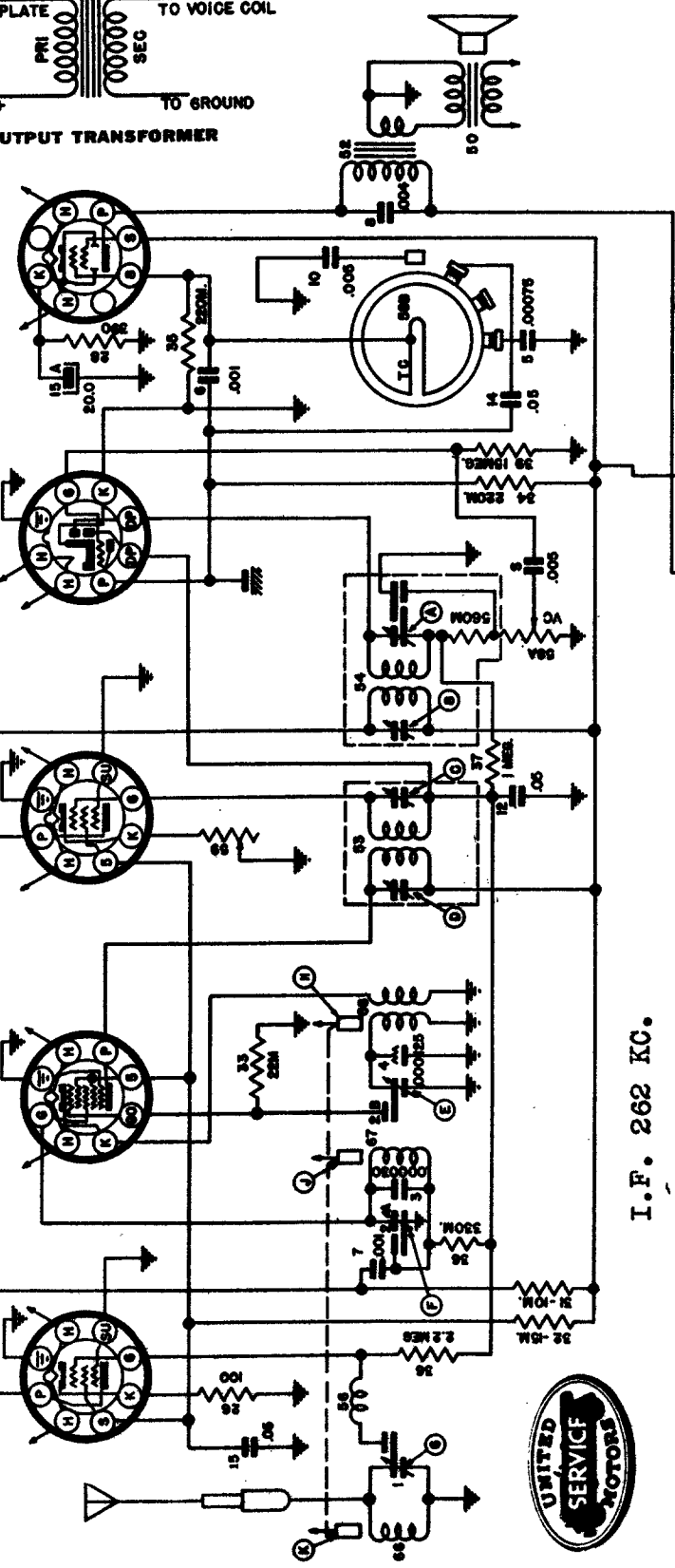

I.F. 262 KC.

RECTIFIER
OZ4

VIBRATOR
57

UNITED MOTORS CHEVROLET MODEL 985793



MANUAL OF 1947 MOST-OFTEN-NEEDED RADIO DIAGRAMS

WARWICK MANUFACTURING CORPORATION

Model C102

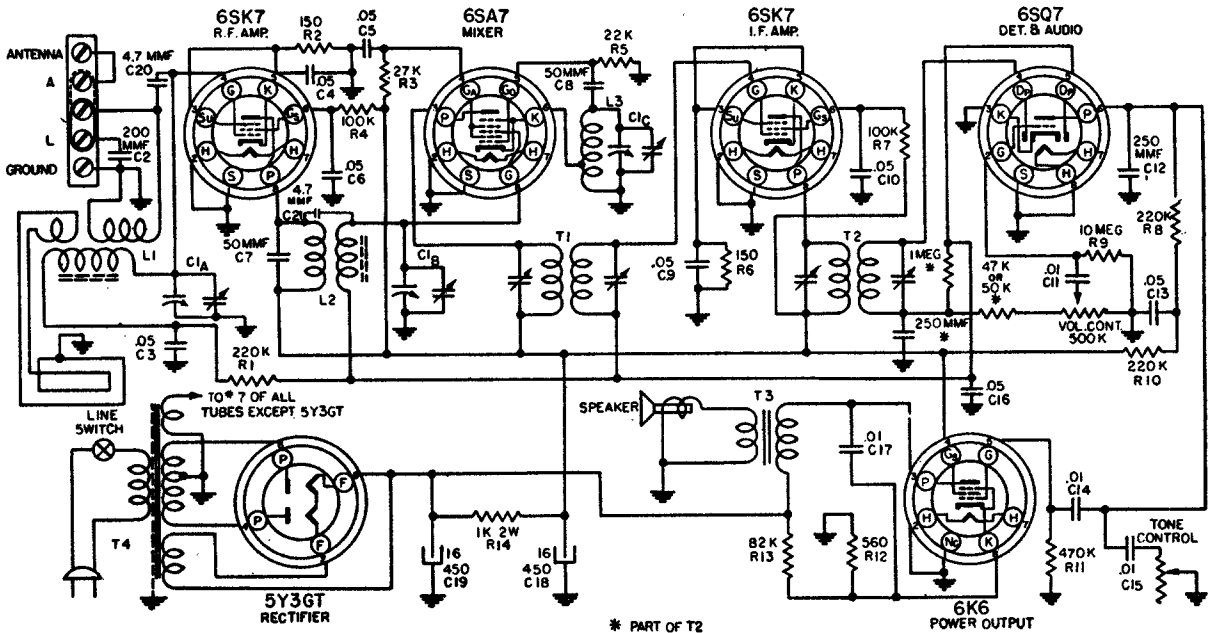
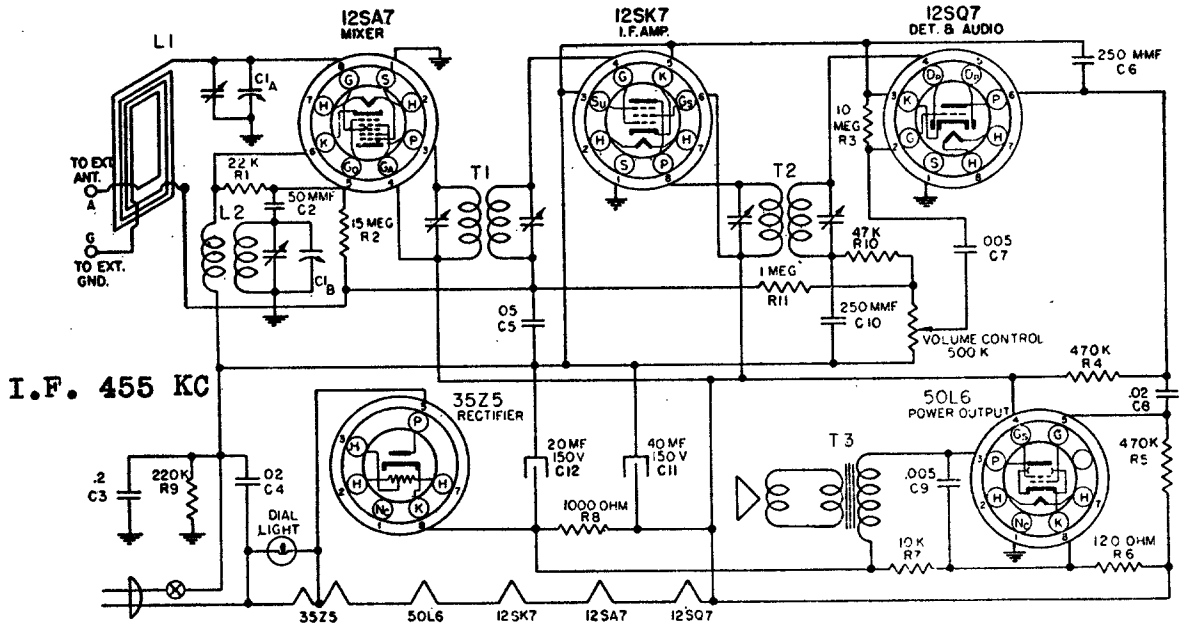

Position of Variable	Generator Freq.	Dummy Ant. mfd.	Generator Connections	Trimmer Adjustment	Trimmer Function
Fully Open	455 KC	.1	6SA7 Grid (Stator of C1B)	T1 T2	I. F.
Fully Open	1725 KC	.00025	Ant. Terminal on Loop	C1C	Osc.
Tune in signal from Generator	1500 KC	.00025	Ant. Terminal on Loop	C1B	R. F.
Tune in signal from Generator	1500 KC	.00025	Ant. Terminal on Loop	C1A	Ant.

MODEL C103

MANUAL OF 1947 MOST-OFTEN-NEEDED RADIO DIAGRAMS

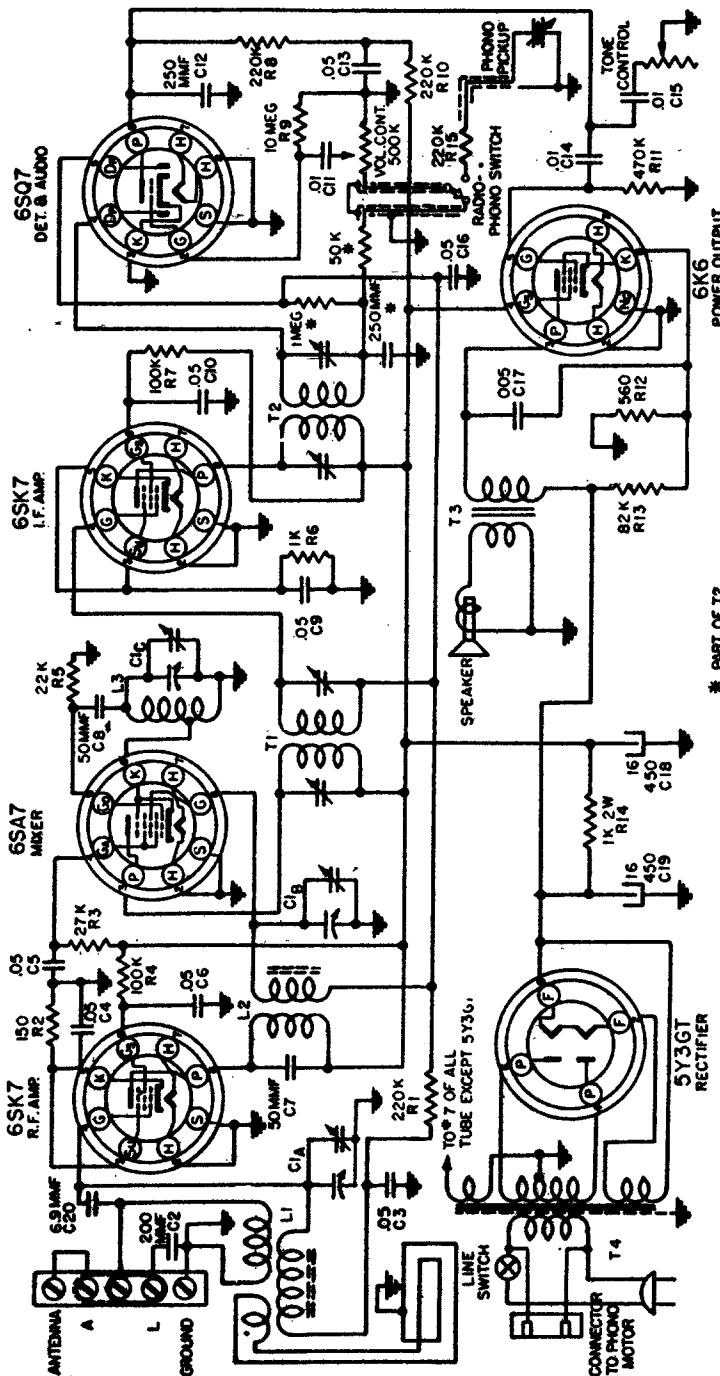

Position of Variable	Generator Frequency	Dummy Ant. Imp.	Generator Connections	Trimmer Adjustment	Trimmer Function
Minimum Capacity (Fully Opened)	455 K.C.	.1	6SA7 Grid (Stator of C1B)	T1 T2	I. F.
Minimum Capacity (Fully Opened)	1725 K.C.	.00025	* Ant. Terminal on Loop	C1C	Osc.
Tune in signal From Generator	1500 K.C.	.00025	* Ant. Terminal on Loop	C1B	R. F.
Tune in signal From Generator	1500 K.C.	.00025	* Ant. Terminal on Loop	C1A	Ant.

*Be sure coupling link is in correct position for external antenna operation. See illustration



CONNECT ANTENNA LEAD HERE

CONNECT GROUND WIRE HERE

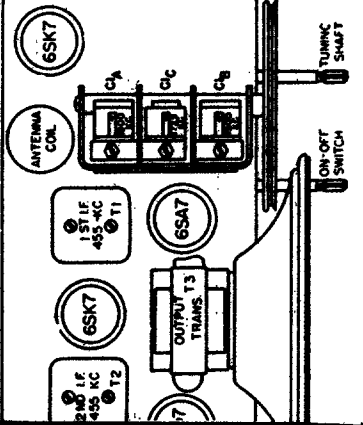
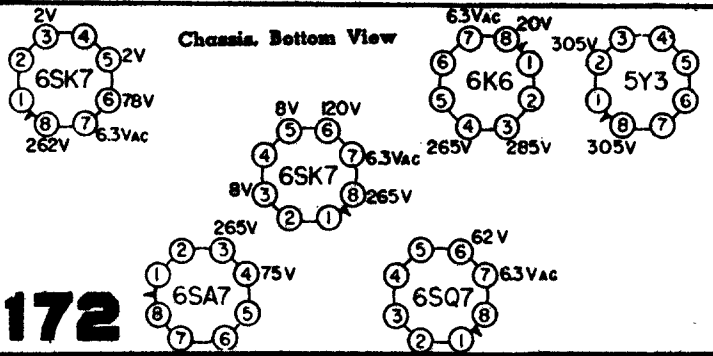

Factory Number P108D

TRUETONE MODEL D-1644

Truetone Model D1645

Factory Model 26A76-650

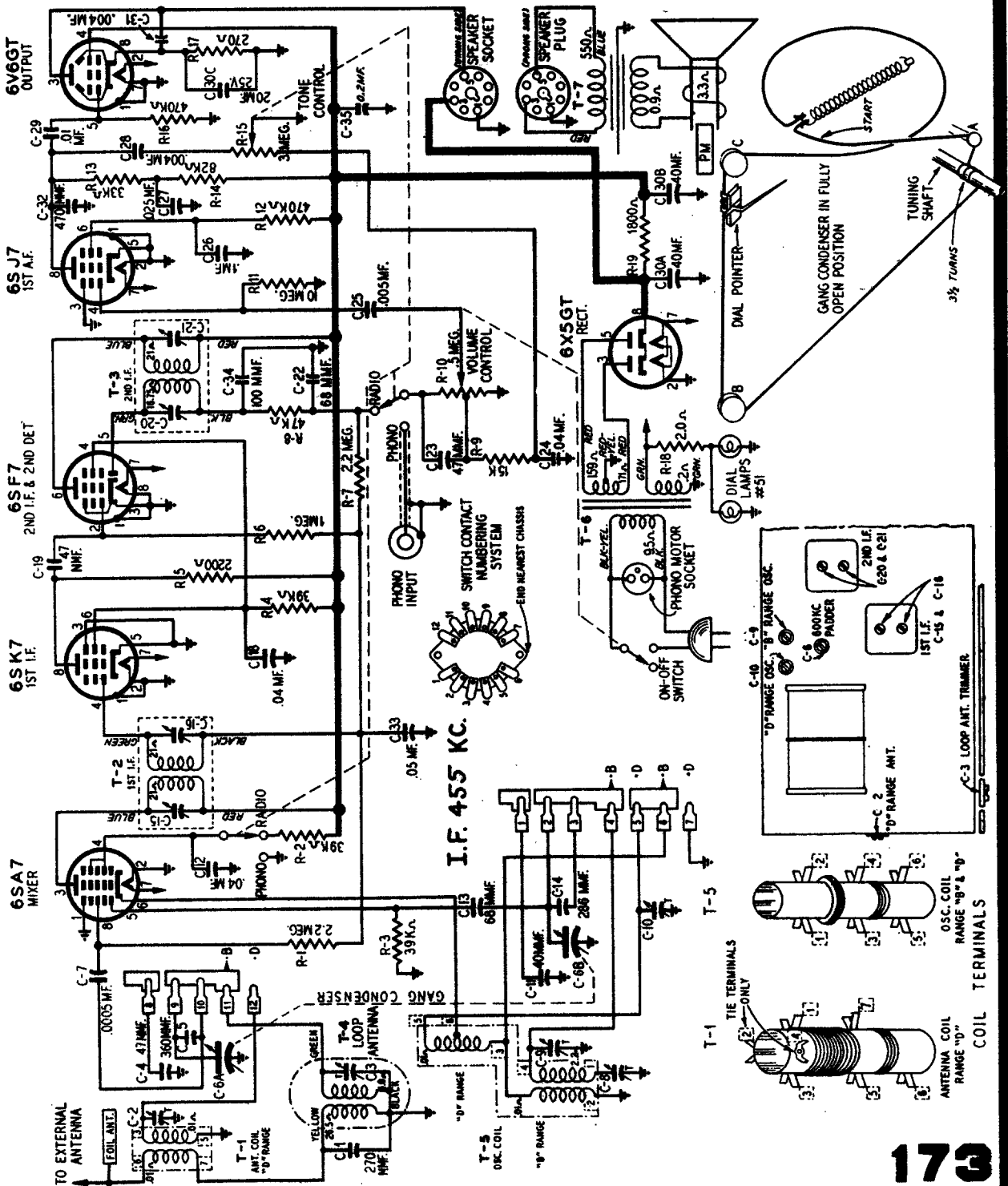

MANUAL OF 1947 MOST-OFTEN-NEEDED RADIO DIAGRAMS

TRUETONE

MODEL D2622

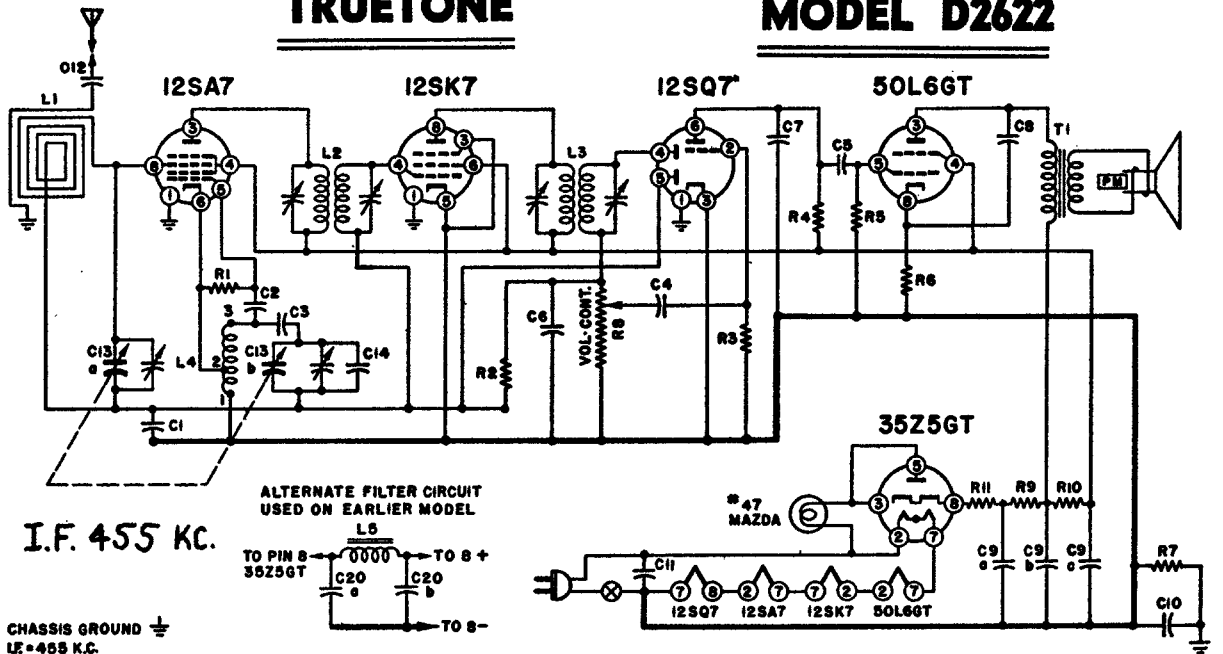

I.F. 455 KC.

ALTERNATE FILTER CIRCUIT USED ON EARLIER MODEL

CHASSIS GROUND \perp
IF=455 KC.

CONDENSERS

Symbol	Capacity	Type
C1.....	.1	mfd.200 V.
C2.....	.00005	mfd.Mica
C3.....	.02	mfd.400 V.
C4.....	.01	mfd.400 V.
C5.....	.01	mfd.400 V.
C6.....	.00025	mfd.Mica
C7.....	.0005	mfd.Mica
C8.....	.02	mfd.400 V.
C9a.....	.30.	mfd. (Elect.)..150 V.
C9b.....	.30.	mfd. (Elect.)..150 V.
C9c.....	.20.	mfd. (Elect.)..150 V.
C10.....	.2	mfd.400 V.
C11.....	.05	mfd.400 V.
C12.....	.005	mfd.600 V.
C13a.....	.00042	mfd. (max.)...Var.
C13b.....	.00018	mfd. (max.)...Var.
C14.....	.00002	mfd.Mica
C20a.....	.30.	mfd. (Elect.)..150 V.
C20b.....	.50.	mfd. (Elect.)..150 V.

RESISTORS

Symbol	Resistance	Type
R1.....	22,000 ohmsC1/2W
R2.....	470,000 ohmsC1/2W
R3.....	10 megohmsC1/2W
R4.....	220,000 ohmsC1/2W
R5.....	470,000 ohmsC1/2W
R6.....	150 ohmsC1/2W
R7.....	150,000 ohmsC1/2W
R8.....	1 megohm	Volume Control
R9.....	150 ohmsC1W
R10.....	1,000 ohmsC1W
R11.....	33 ohmsC1W

VOLTAGE DATA:—

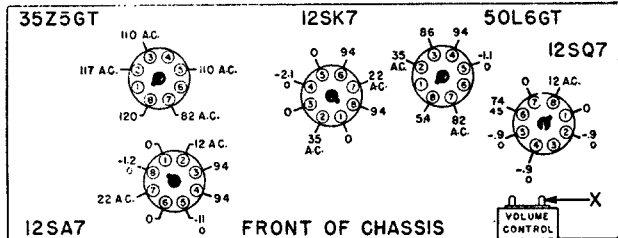

Bottom View of Chassis, Showing Voltages

All readings made between Tube Socket Terminals and Switch Lug on volume control (Point "X" on drawing). Measured on a 117 Volt A.C. line. Volume control full on. Dial tuned to low frequency end, no signal. Voltages indicated obtained on Vacuum Tube voltmeter. A second voltage reading is shown made with a 1000 ohm-per-volt meter when use of this instrument would result in appreciably lower readings.

COILS

Symbol	Description
L1.....	Loop
L2.....	1st I. F. Trans.
L3.....	2nd I. F. Trans.
L4.....	Osc. Coil
L5.....	Choke, Filter

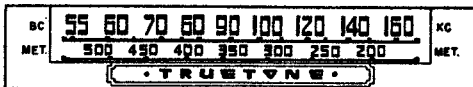
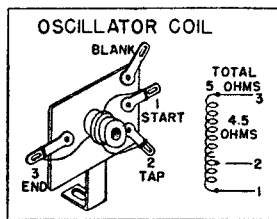

VOLUME CONTROL AND ON-OFF SWITCH

STATION SELECTOR CONTROL

MODEL D2622

DIAL STRINGING AND POINTER SETTINGS:—

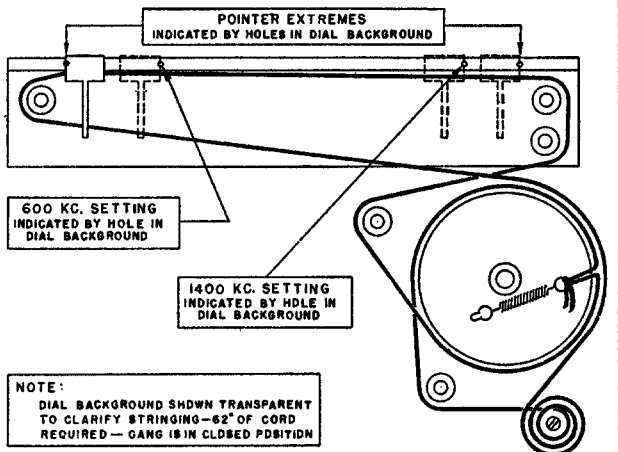

NOTE:
DIAL BACKGROUND SHOWN TRANSPARENT TO CLARIFY STRINGING—62" OF CORD REQUIRED—GANG IS IN CLOSED POSITION

MANUAL OF 1947 MOST-OFTEN-NEEDED RADIO DIAGRAMS

35L6GT
POWER
OUTPUT

12S17
1ST AUDIO

12SF7
2ND DET. AVC

12SA7
CONVERTER

12SK7
R.F. AMP

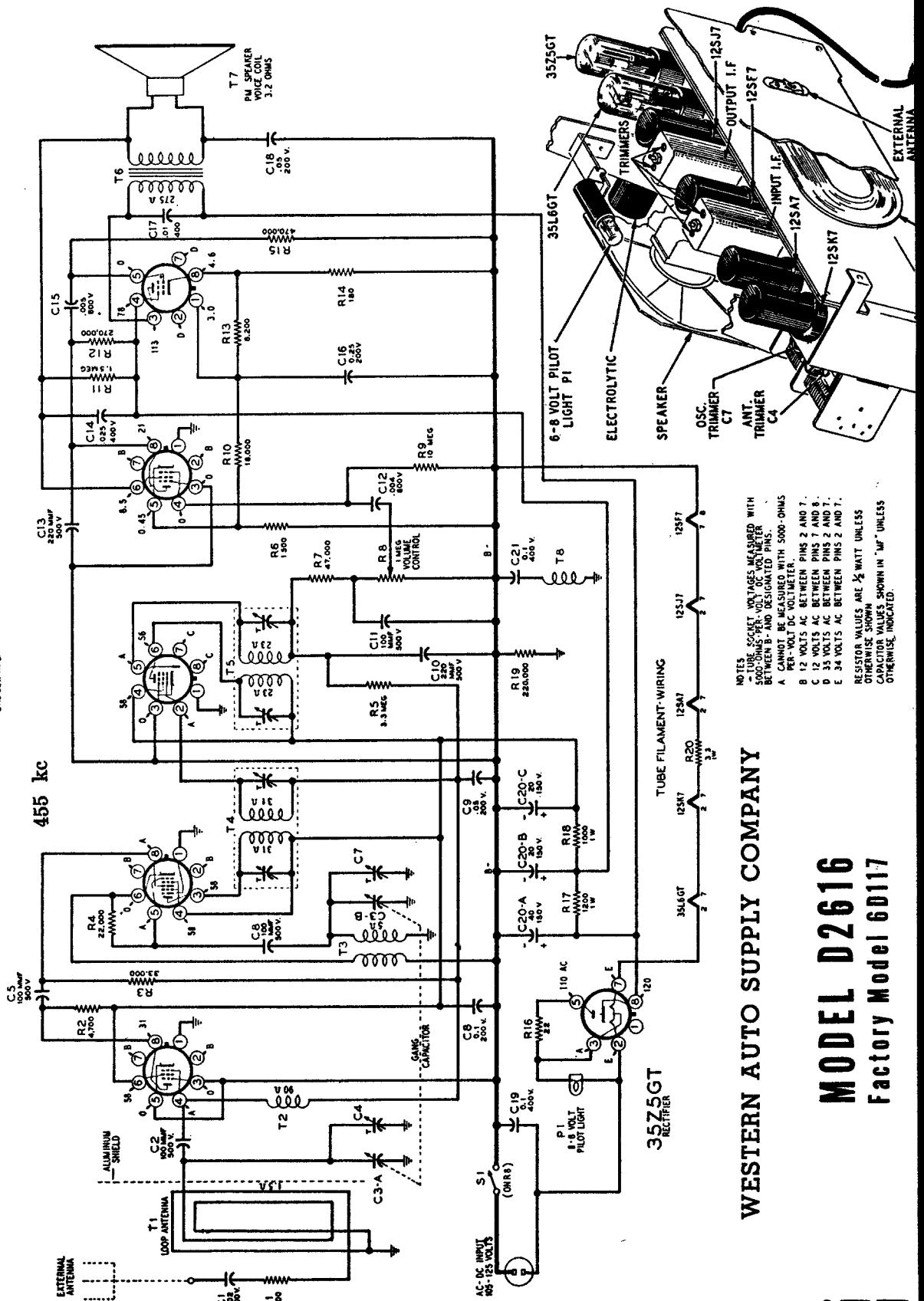

NOTES
 1. ALL VOLTAGE VALUES MEASURED WITH 500 OHM PER VOLT RESISTANCE BETWEEN B- AND DESIGNATED PINS.
 A. CANNOT BE MEASURED WITH 5000-OHMS PER-VOLT DC VOLTMETER.
 B. 12 VOLTS AC BETWEEN PINS 2 AND 7.
 C. 12 VOLTS AC BETWEEN PINS 7 AND 8.
 D. 35 VOLTS AC BETWEEN PINS 2 AND 7.
 E. 34 VOLTS AC BETWEEN PINS 2 AND 7.
 RESISTOR VALUES ARE 1/2 WATT UNLESS OTHERWISE SHOWN
 CAPACITOR VALUES SHOWN IN "UF" UNLESS OTHERWISE INDICATED.

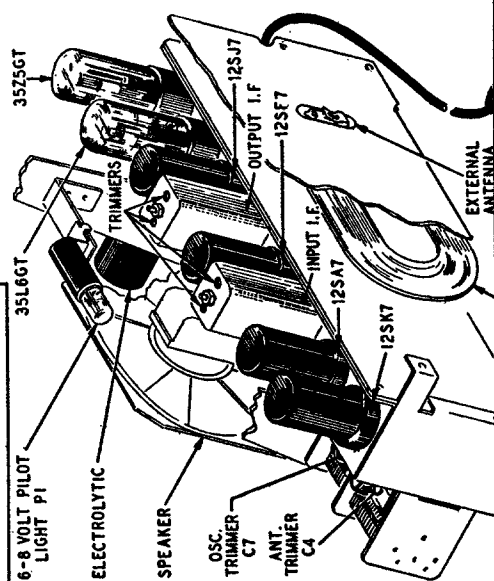

WESTERN AUTO SUPPLY COMPANY

MODEL D2616
Factory Model 6D117

MANUAL OF 1947 MOST-OFTEN-NEEDED RADIO DIAGRAMS

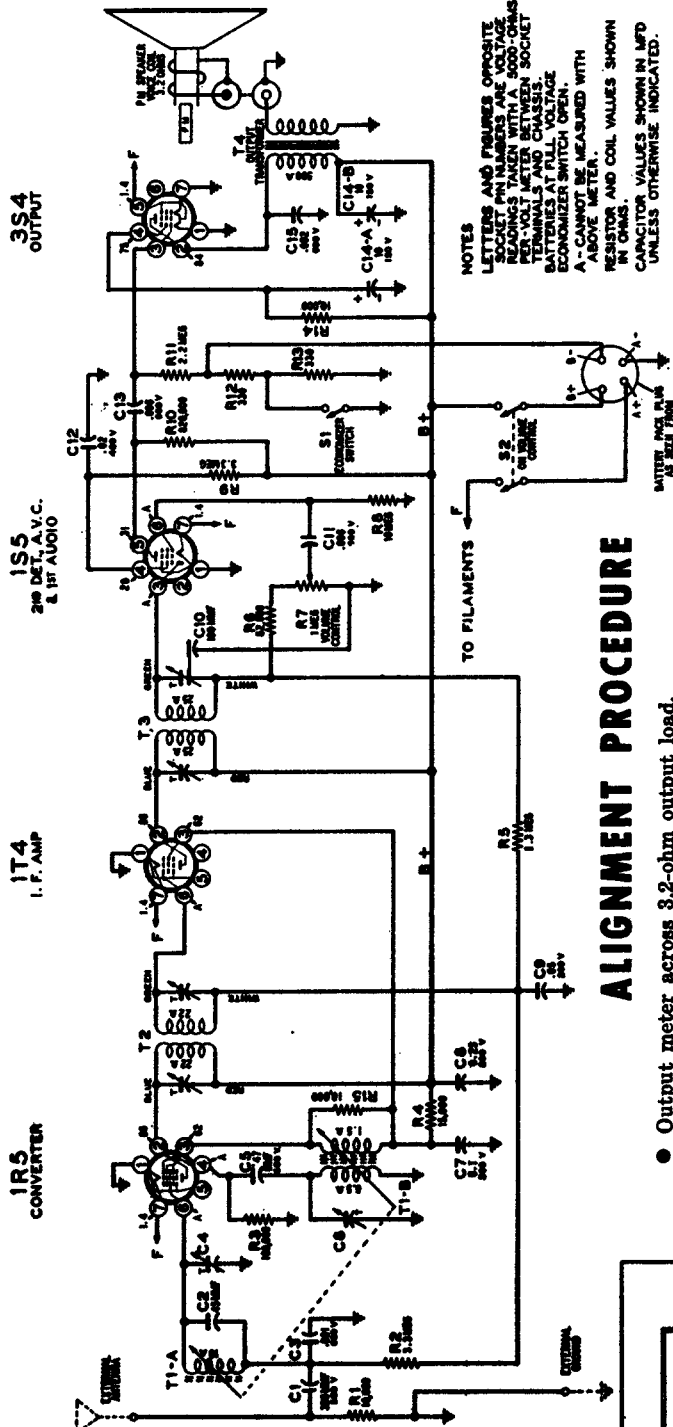

NOTES
 LETTERS AND FIGURES OPPOSITE SOCKET PIN NUMBERS ARE VOLTAGE READINGS TAKEN WITH A 5000-OHM PER-VOLT METER BETWEEN SOCKET TERMINALS AT FULL VOLTAJE ECONOMIZER SWITCH OPEN.
 A-CANNOT BE MEASURED WITH ABOVE METER.
 RESISTOR AND COIL VALUES SHOWN IN OHMS.
 CAPACITOR VALUES SHOWN IN MFD UNLESS OTHERWISE INDICATED.

ALIGNMENT PROCEDURE

- Output meter across 3.2-ohm output load.
- Align for maximum output. Reduce input as needed to keep output near 0.4 volts.
- Connect ground post of signal generator to radio chassis.

SIGNAL GENERATOR		Tuner Setting	Adjust for Maximum Output (in order shown)
Frequency	Coupling Capacitor		
455 kc	.1 mf	Iron cores all the way out	Trimmers on output and input I.F. cans
1700 kc	.1 mf	Iron cores all the way out	Oscillator trimmer C6
1700 kc	200 mmf	Iron cores all the way out	Antenna trimmer C4
1400 kc	200 mmf	Turn dial to 1400 kc	Adjust position of ant. coil (see coil view) *

COIL VIEW

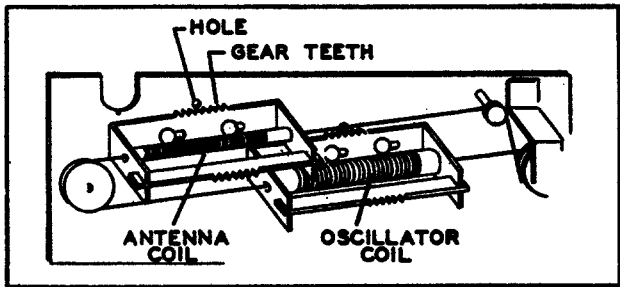

The antenna coil assembly is movable left or right. When making the adjustment as required in the alignment procedure, move the coil assembly very slowly, either by hand or by pivoting one edge of a screwdriver blade in the hole and engaging the blade in the gear teeth of the coil form.

*This adjustment and the previous adjustment are interlocking; therefore repeat the two adjustments alternately for best results.

WESTERN AUTO SUPPLY
MODEL D2665

Factory Model 4B114 - Series A

Jruetone Model D3615

Factory Model 25BD2-606

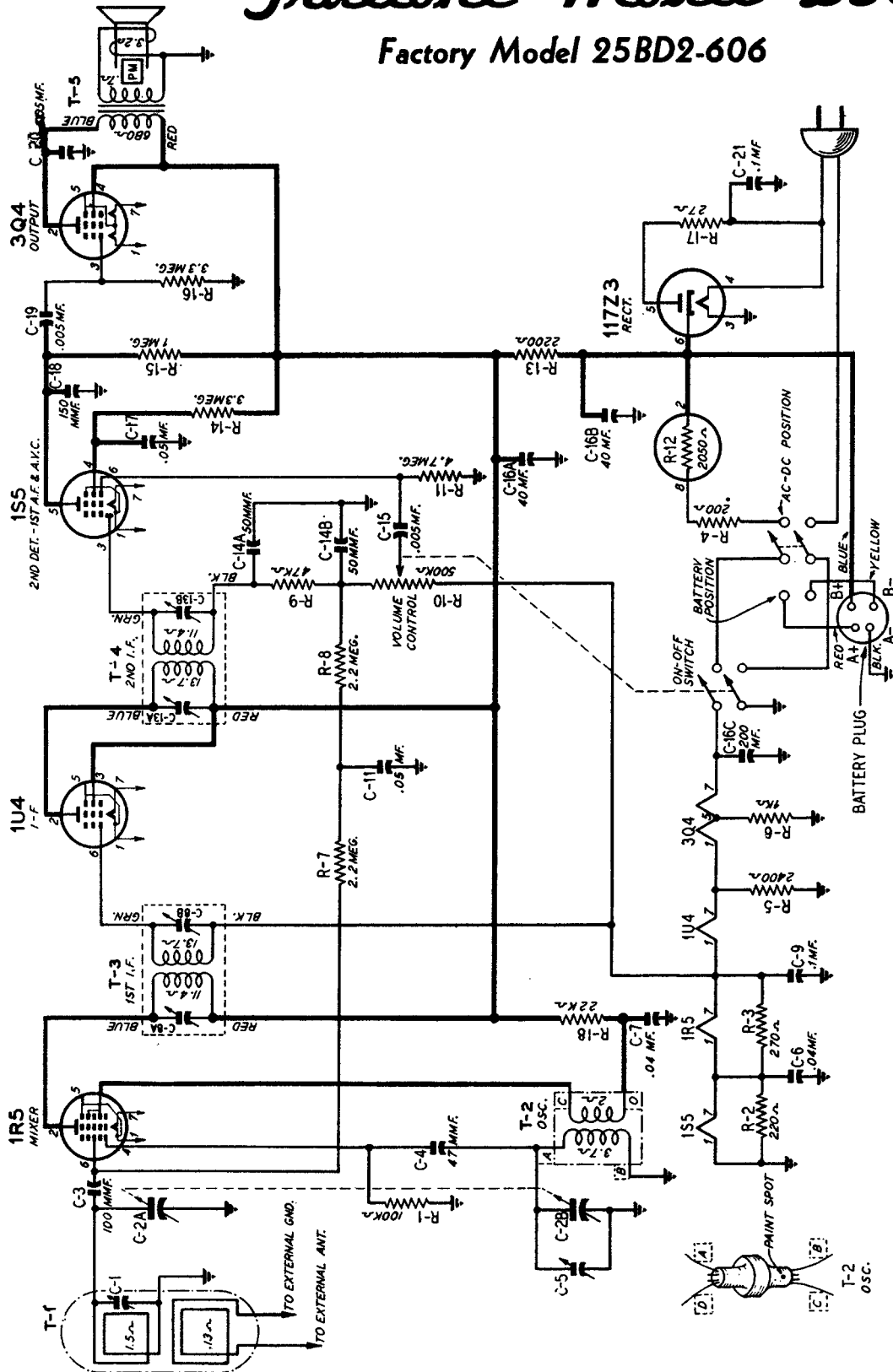

"A" Battery Supply—7½ volts
50 Mc.
"B" Battery Supply—90 volts 13
Mc.

Intermediate Frequency.....455 KC
Selectivity.....at 1000 KC, 41 KC wide at 1000 times signal

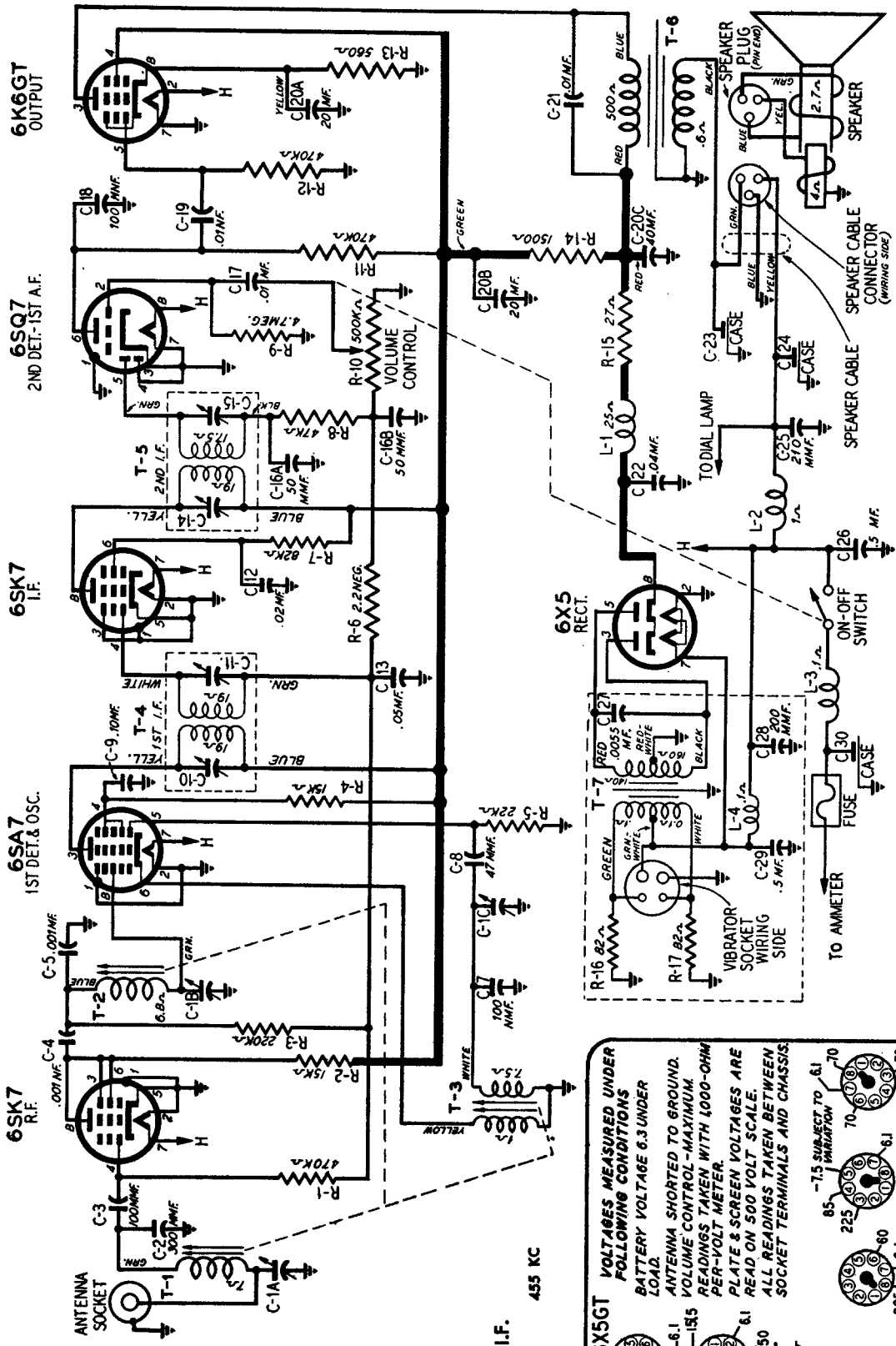

6X5 or 6X5GT RECT.

VOLTAGES MEASURED UNDER FOLLOWING CONDITIONS:
 BATTERY VOLTAGE 6.3 UNDER LOAD.
 ANTENNA SHORTED TO GROUND.
 VOLUME CONTROL-MAXIMUM READINGS TAKEN WITH 1000-OHM PER-VOLT METER.
 PLATE & SCREEN VOLTAGES ARE READ ON 500 VOLT SCALE.
 ALL READINGS TAKEN BETWEEN SOCKET TERMINALS AND CHASSIS.

270	6.1	85	-7.5 SUBJECT TO 6.1	70	6SK7 R.F.
225	250	225	PARA-PHON	80	6SA7 1ST DET. & OSC.
6.1	6.1	225	L 6.1	70	6SK7 I.F.
6.1	6.1	70	L 70	80	6SK7 2ND DET. / 1ST A.F.

Tru-tone Model D4630

Factory Model 26C19-61

3Q5GT
OUTPUT

1H5GT
2ND DET.
1ST AUDIO
A.V.C.

1N5GT
I.F. AMP.

1A7GT
CONVERTER

EXTERNAL
ANTENNA

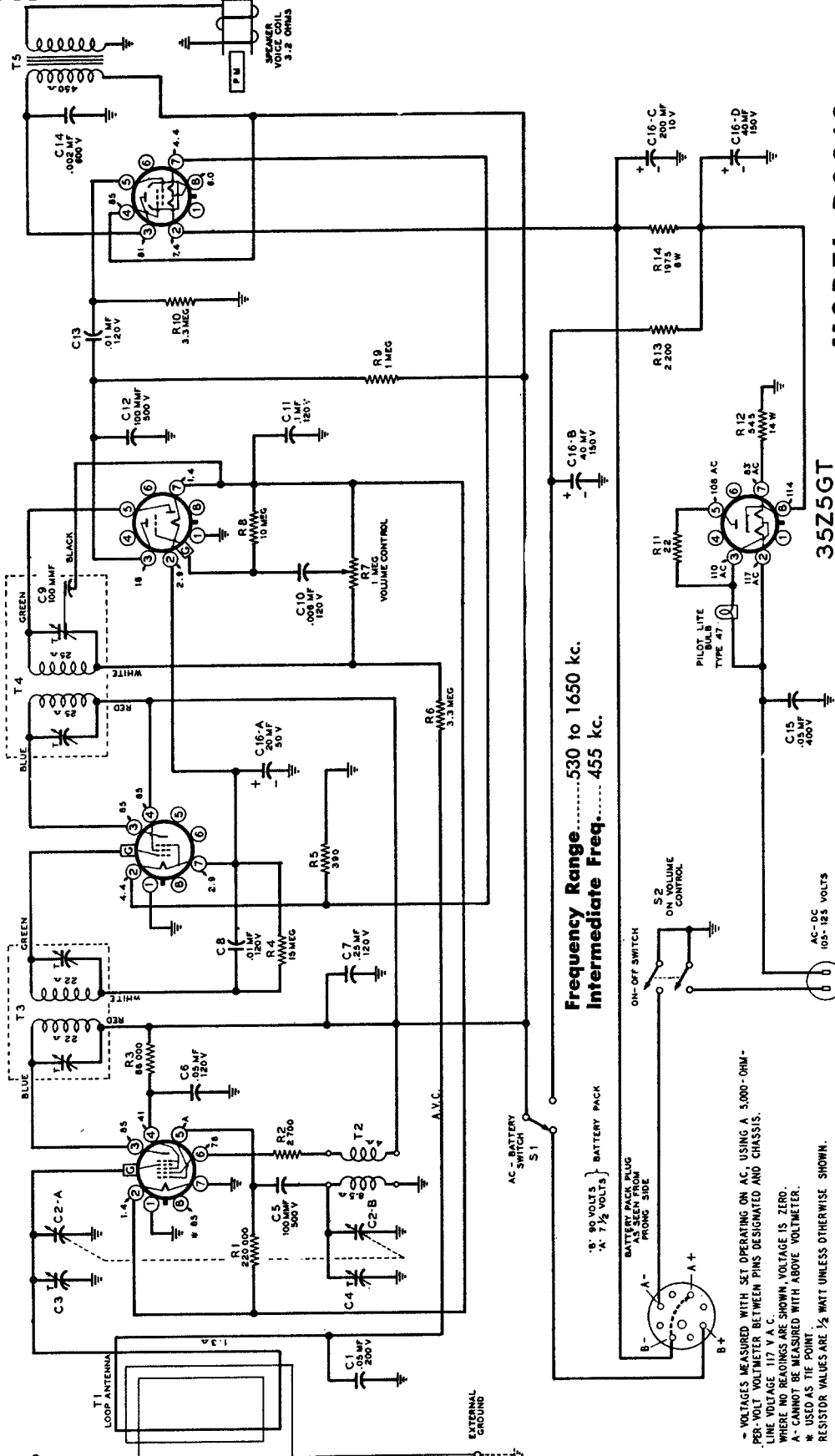

Frequency Range.....530 to 1650 kc.
Intermediate Freq.....455 kc.

MODEL D3619
Factory Model 5P110

3Z55GT
RECTIFIER

TRUETONE RADIO

- VOLTAGES MEASURED WITH SET OPERATING ON AC, USING A 5,000- Ω -IMP. PER-VOLT VOLTMETER BETWEEN PINS DESIGNATED AND CHASSIS.
- LINE VOLTAGE 117 V. A. C.
- WHERE NO READINGS ARE SHOWN VOLTAGE IS ZERO.
- A- CANNOT BE MEASURED WITH ABOVE VOLTMETER.
- * USED AS TIE POINT.
- RESISTOR VALUES ARE 1/2 WATT UNLESS OTHERWISE SHOWN.

Truetone Model D2607

Factory Model 23P1-634

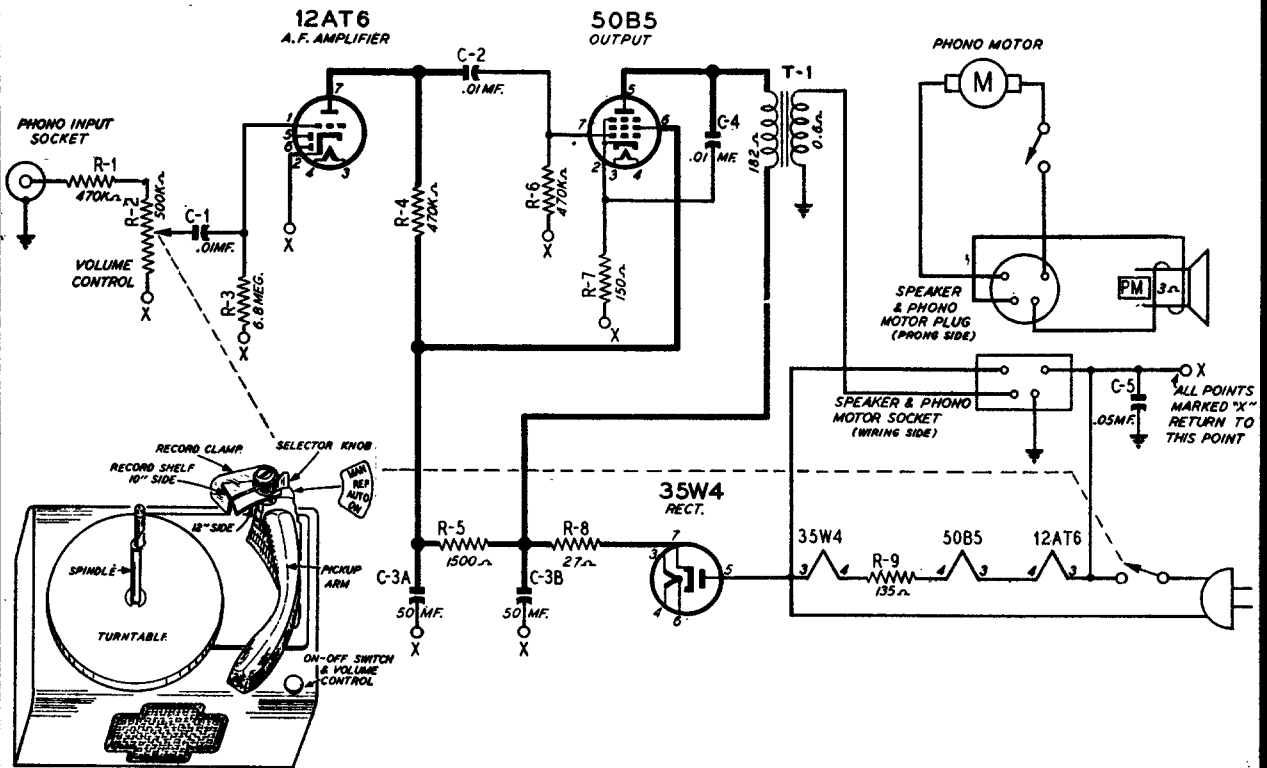

TRUETONE

MODEL D2605

Factory Model 2AW2

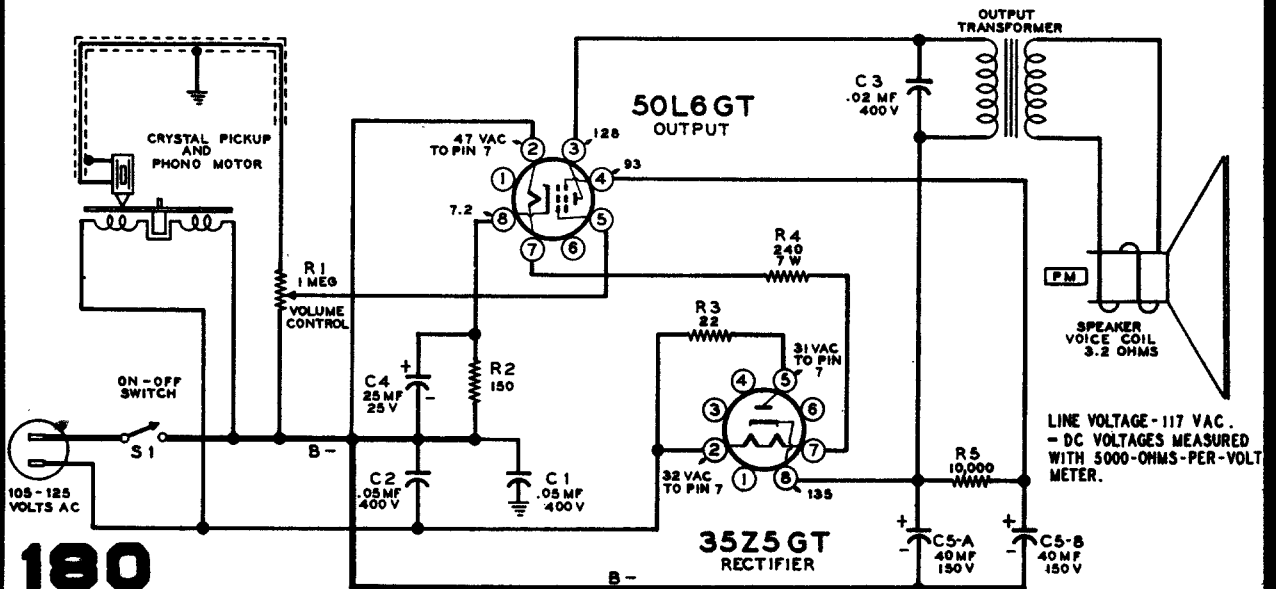

MANUAL OF 1947 MOST-OFTEN-NEEDED RADIO DIAGRAMS

Westinghouse Electric

H-104
MAHOGANY

H-105
WALNUT

H-107
MAHOGANY

H-108
WALNUT

Steps	Connect Signal Generator to—	Adjust Signal Generator to—	Tune Radio Dial to —	Adjust
1	6SK7, i-f amplifier, control grid through a 0.1 mfd. capacitor	455 kc	550 kc	secondary trimmer of 2nd i-f transformer for maximum output
2	6SK7, i-f amplifier, control grid through a 0.1 mfd. capacitor	455 kc	550 kc	primary trimmer of 2nd i-f transformer for maximum output
3	6SA7, converter, control grid through a 0.1 mfd. capacitor	455 kc	550 kc	secondary trimmer of 1st i-f transformer for maximum output
4	6SA7, converter, control grid through a 0.1 mfd. capacitor	455 kc	550 kc	primary trimmer of 1st i-f transformer for maximum output
5	6SA7, converter, control grid through a 0.1 mfd. capacitor	455 kc	550 kc	"peak" all i-f trimmers for maximum output
6	6SK7, r-f amplifier, control grid through a 0.1 mfd. capacitor	455 kc	550 kc	i-f rejection trap trimmer for minimum output
7	"B.C." antenna terminal through a 200 mmfd. capacitor	600 kc	600 kc	broadcast band "oscillator padder" for maximum output
8	"B.C." antenna terminal through a 200 mmfd. capacitor	1620 kc	minimum capacity stop	broadcast band "oscillator trimmer" for maximum output
9	recheck steps 7 and 6 in order given			
10	radiated signal (no actual connection)	1400 kc	1400 kc	broadcast band "antenna trimmer" for maximum output
11	set phono-band switch on position "4"			
12	"S.W." antenna terminal through 400 ohm resistor	16.5 mc	minimum capacity stop	short wave "oscillator trimmer" for maximum output
13	radiated signal (no actual connection)	16 mc	16 mc	short wave "antenna trimmer" for maximum output

PUSH BUTTONS

Push buttons 1 to 3 are designed to receive stations from 900 to 1600 kc; push buttons 4 to 6 are designed to receive stations from 540 to 900 kc.

1. Turn on radio and allow it to warm up for five minutes.
2. Set the phono-band switch on "BROADCAST." Tune in the desired station in the frequency range 900 to 1600 kc.
3. Reset the phono-band switch on "PUSH BUTTON" and depress the first push button (right button, viewed from the front). Adjust L14, using a small long-handled screwdriver, to receive the station. Adjust C42 for maximum volume on the station.
4. Return the band switch to "BROADCAST" to make sure that the push button has been set to the desired station.
5. Adjust remaining push buttons in the same manner.

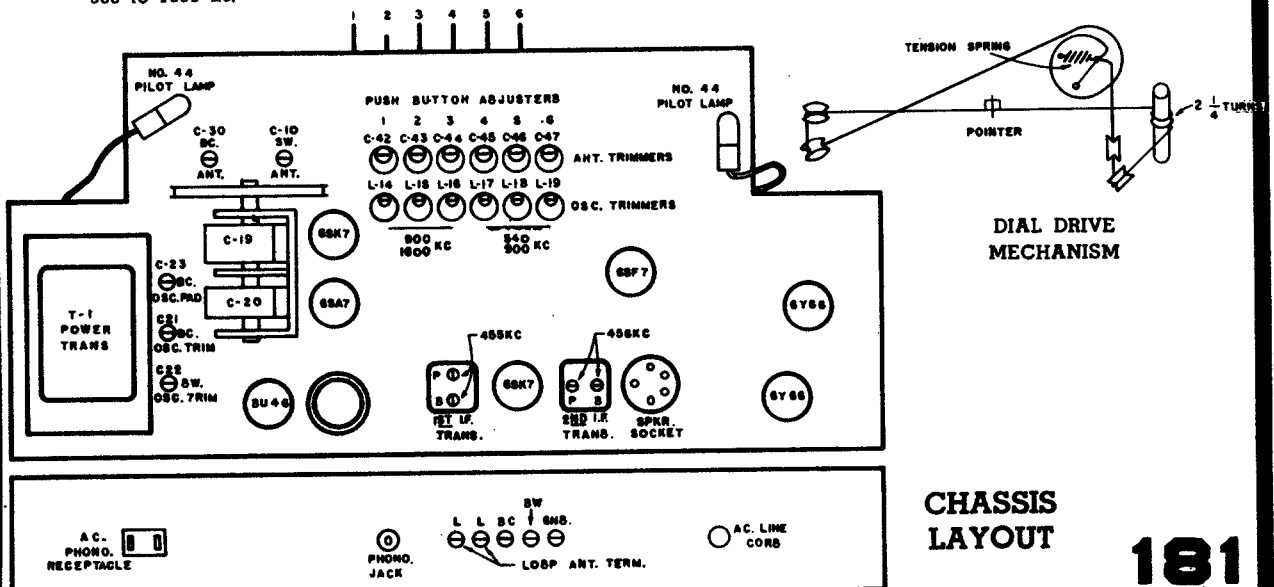

MANUAL OF 1947 MOST-OFTEN-NEEDED RADIO DIAGRAMS

Westinghouse Electric
Models H-104, H-105,
H-107, H-108.
Chassis for models
H-110, H-111, H-137,
& H-138 are similar
to the above models.

H-104 & H-105

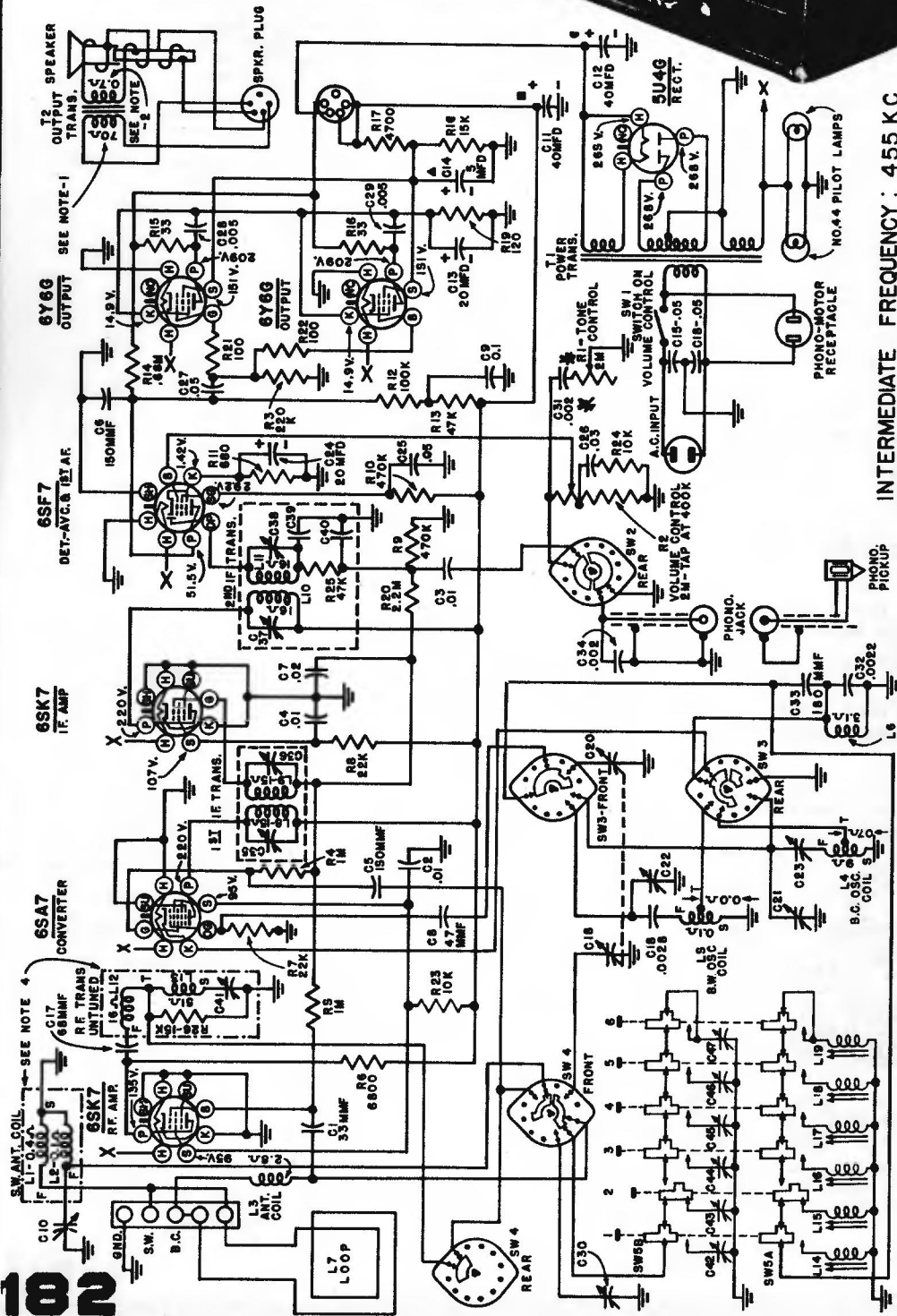

INTERMEDIATE FREQUENCY: 455 KC

4. DOT-DASH LINE DEMOTES ASSEMBLY OF COMPONENT PARTS UNSHIELDED.
5. ALL VOLTAGES MEASURED FROM CHASSIS (END.) USING 20,000 OHMS/VOLT METER.
LINE VOLTAGE 117 V. A.C. MAX. VOLUME CONTROL SETTING AT NO SIGNAL CONDITIONS.
READINGS SHOULD APPROXIMATE THE VALUES SHOWN WITHIN 20 PERCENT.

*R1-C31 in some later models were wired across R14 for tone control action.

H-104 H-105 H-107 H-108
MAHOAGNY WALNUT MAHOAGNY WALNUT

NOTES -
1. SPEAKER PLUG REMOVED.
2. VOICE COIL DISCONNECTED.
3. SWITCH SW2-3 & 4 SHOWN AS VIEWED FROM FRONT OF SET IN P.B.-B.C. POSITION.
EXTREME COUNTER CLOCKWISE POSITION IS PHONO.
SECOND POSITION CLOCKWISE IS P.B.-B.C. BAND.
THIRD POSITION CLOCKWISE IS MANUAL B.C. BAND.
FOURTH POSITION CLOCKWISE IS S.W. BAND.

MANUAL OF 1947 MOST-OFTEN-NEEDED RADIO DIAGRAMS

WILCOX GAY CORPORATION — CHARLOTTE, MICHIGAN

Models 6B10-6B20-6B30-6B32

Schematic Diagram—Serial Numbers 701, 752 to 703, 631

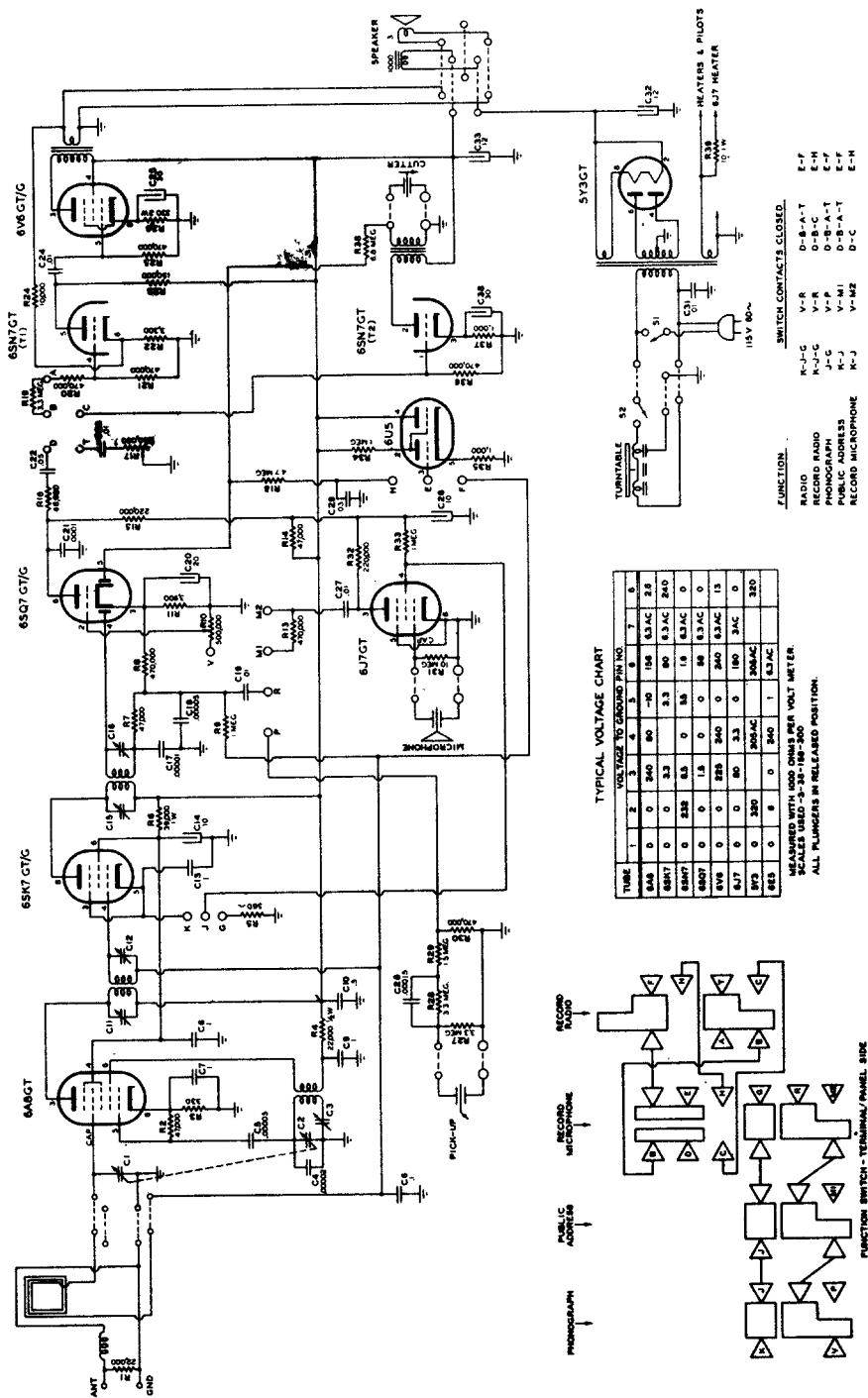

TYPICAL VOLTAGE CHART

TUBE	1	2	3	4	5	6	7	8
6A8	0	240	90	10	14	63 AC	2.8	
6S7	0	2.3	0	3.3	80	63 AC	240	
6K7	0	2.3	0	6.5	18	63 AC	0	
6V6	0	1.8	0	0	0	63 AC	15	
5Y3	0	0	280	240	0	240	63 AC	0
6J7	0	0	80	3.3	0	180	3 AC	0
6E5	0	330	0	240	1	63 AC	320	

MEASURED WITH 400 OHMS PER VOLT METER
 SCALES USED—5-30-100-300
 ALL PLUMBERS IN RELEASED POSITION.

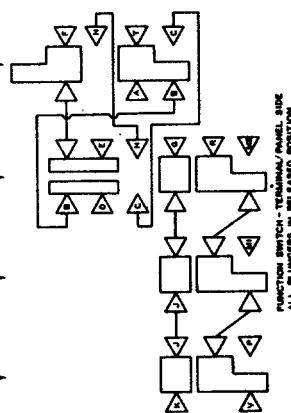

An OUTPUT METER or other indication device should be used for accuracy in making ganging adjustments. If an output meter is not available, the tuning indicator may be used as an output indicator. Resonance of the circuits will be indicated by the maximum closing of the tuning eye.

Alignment data continued on the next page.

MANUAL OF 1947 MOST-OFTEN-NEEDED RADIO DIAGRAMS

Alignment Data Models 6B10, 6B20, 6B30, 6B32, 6B40

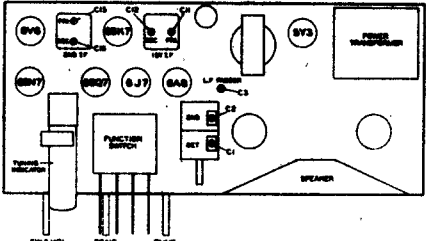
1. Connect signal generator to control grid of 6A8 tube
 2. Set volume control to near maximum.
 3. Set tuning dial at 1500 K.C.
- 

4. Set signal generator at 456 K.C.
5. Align trimmers in the following order:

- | | |
|-----------------------------|-----------------------------|
| 1. Secondary 2nd I.F. (C16) | 3. Secondary 1st I.F. (C12) |
| 2. Primary 2nd I.F. (C15) | 4. Primary 1st I.F. (C11) |

Repeat procedure to obtain greatest accuracy in the adjustment of the trimmer condensers.

6. Connect signal generator to the ANT and GND leads.
7. Turn condenser gang to full maximum capacity and check position of dial pointer with reference line on the scale which is the last graduation below the 550 K.C. calibration.

SIGNAL GENERATOR
FREQUENCY

DIAL
SETTING

TRIMMER

600 K.C.
1400 K.C.
1400 K.C.

600 K.C.
1400 K.C.
1400 K.C.

L.F. Pad (C3)
Osc. (C2)
Det. (C1)

Models 6A10-6A20 Schematic Diagram

WILCOX GAY CORPORATION

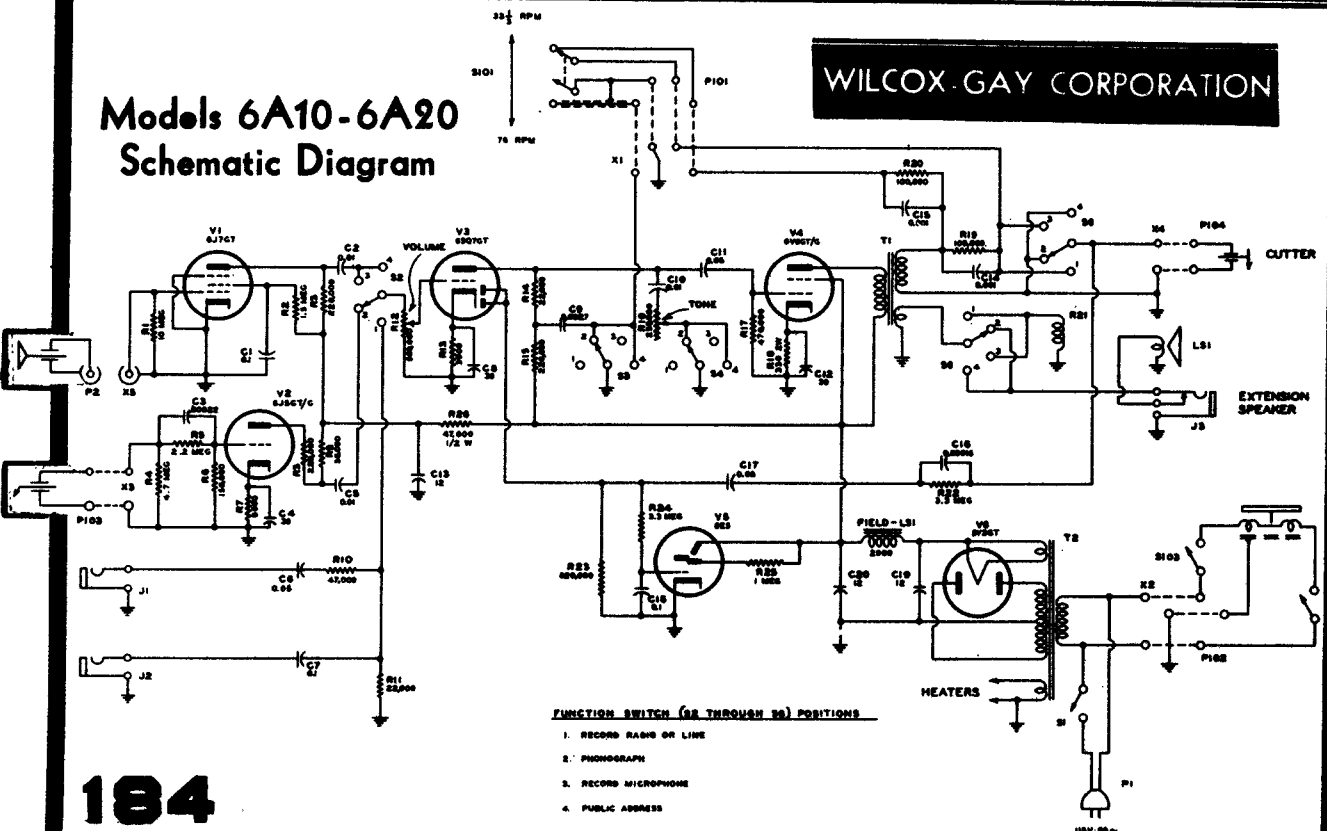

- FUNCTION SWITCH (S1 THROUGH S4) POSITIONS**
1. RECORD RADIO OR LINE
 2. PHONOGRAPH
 3. RECORD MICROPHONE
 4. PUBLIC ADDRESS

MANUAL OF 1947 MOST-OFTEN-NEEDED RADIO DIAGRAMS

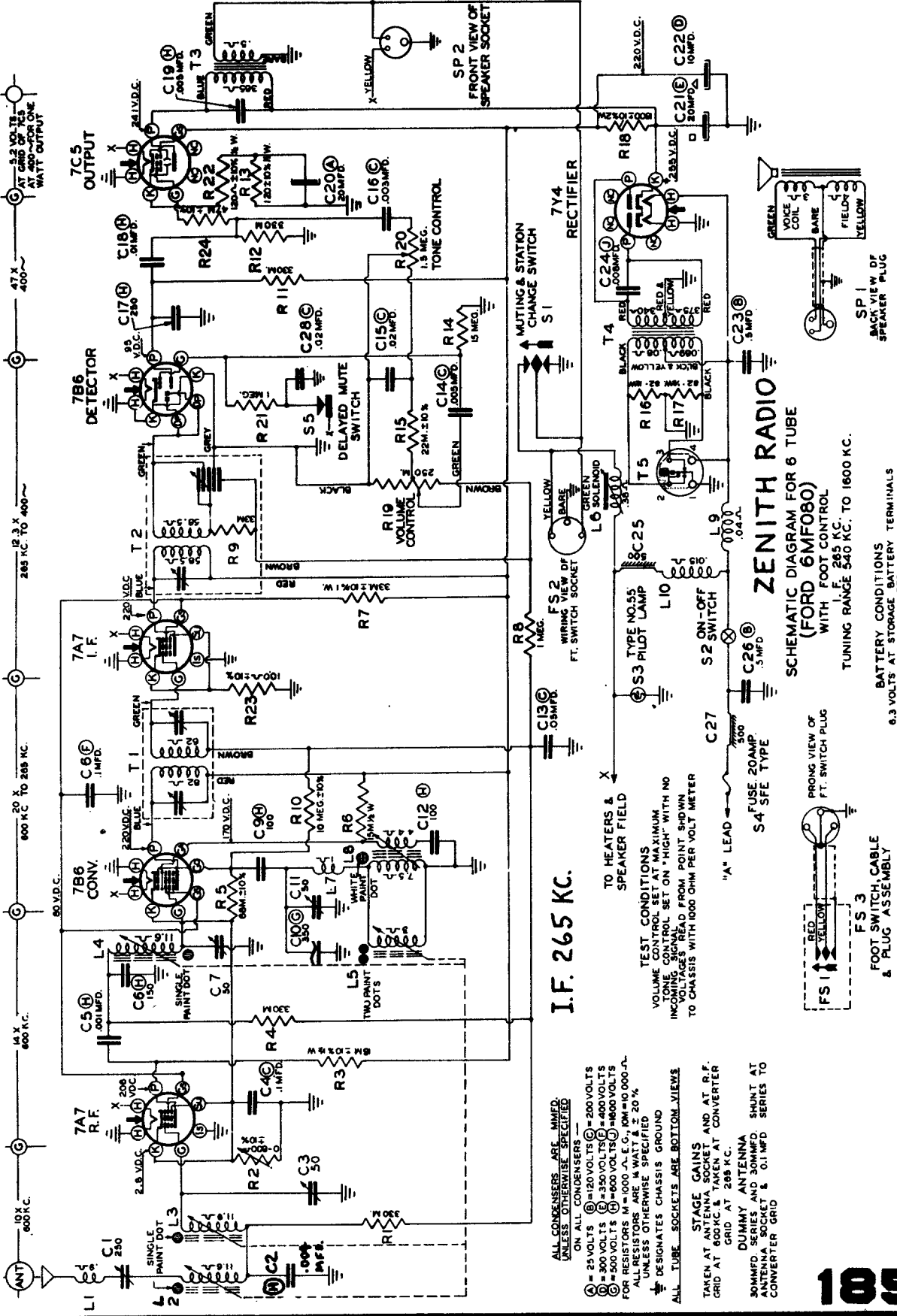

I.F. 265 KC.

ZENITH RADIO (FORD 6MFO80) WITH FOOT CONTROL

TUNING RANGE 540 KC. TO 1600 KC.

- ALL CONDENSERS ARE MIMED UNLESS OTHERWISE SPECIFIED
- ON ALL CONDENSERS
- Ⓐ = 25 VOLTS Ⓑ = 50 VOLTS Ⓒ = 100 VOLTS Ⓓ = 200 VOLTS Ⓔ = 350 VOLTS Ⓕ = 500 VOLTS Ⓖ = 600 VOLTS Ⓗ = 800 VOLTS Ⓙ = 1000 VOLTS
- FOR RESISTORS ARE WAT. 1% UNLESS OTHERWISE SPECIFIED 20%
- ⚡ DESIGNATES CHASSIS GROUND
- ALL TUBE SOCKETS ARE BOTTOM VIEWS
- STAGE GAINS AND AT R.F. GRID AT 600 KC. & TAKEN AT CONVERTER GRID AT 265 KC.
- DUMMY ANTENNA SHUNT AT ANTENNA SOCKET & 0.1 MFD SERIES TO CONVERTER GRID

MANUAL OF 1947 MOST-OFTEN-NEEDED RADIO DIAGRAMS

Zenith Radio Corp.

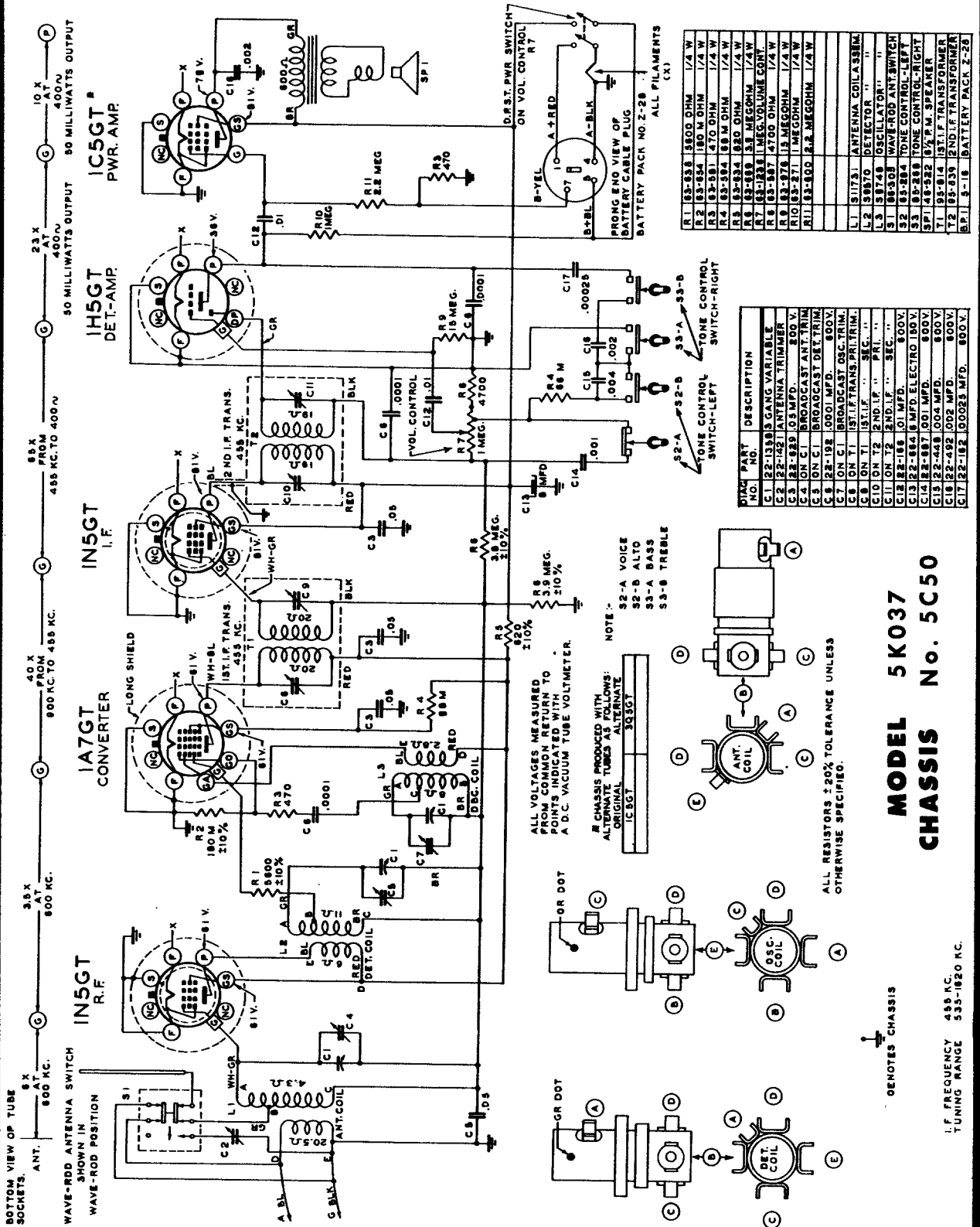

MANUAL OF 1947 MOST-OFTEN-NEEDED RADIO DIAGRAMS

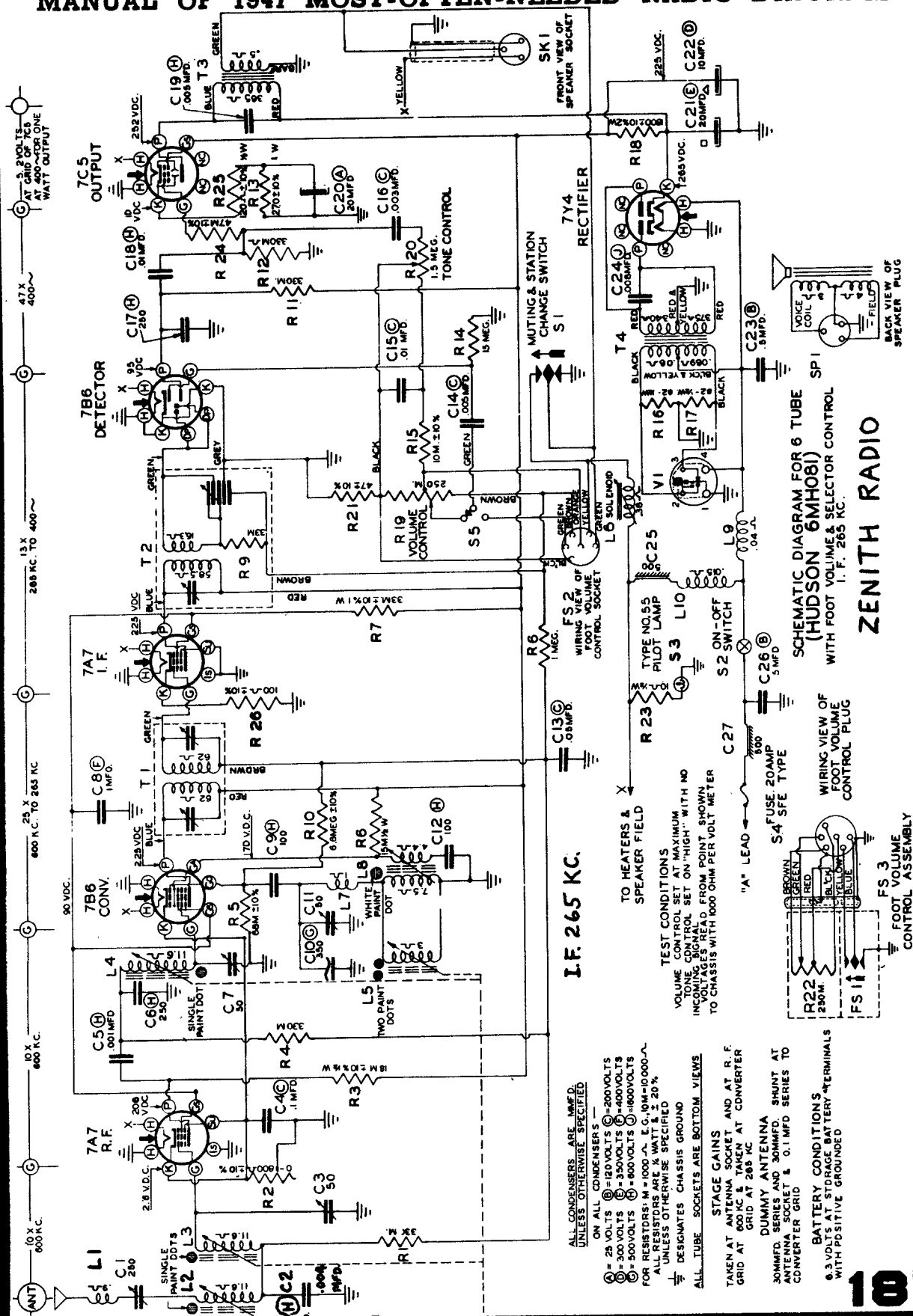

SCHEMATIC DIAGRAM FOR 6 TUBE (HUDSON 6MH081) WITH FOOT VOLUME & SELECTOR CONTROL I. F. 265 KC.

ZENITH RADIO

MANUAL OF 1947 MOST-OFTEN-NEEDED RADIO DIAGRAMS

Zenith Radio Corp.

MODELS 6D014-6D029

CHASSIS No. 6C01

ALIGNMENT PROCEDURE

CONNECT OSCILLATOR TO	DUMMY ANTENNA	INPUT SIG. FREQUENCY	SET DIAL AT	TRIMMERS	PURPOSE
Converter Grid	.5 Mfd.	455 Kc.	600 Kc.	C-8, C-9, C-11, C-12	Align I. F.
{ One Turn Loop Coupled Loosely to Wave Magnet }	--	1600 Kc.	1600 Kc.	C-7	Set Oscillator to Dial Scale.
	--	1400 Kc.	1400 Kc.	C-5	Align detector
	--	1400 Kc.	1400 Kc.	C-2	Align antenna stage

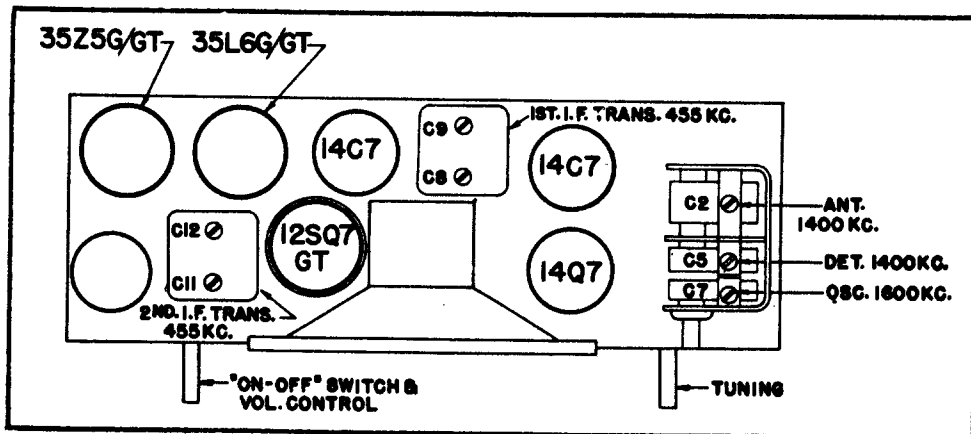

TUBE AND TRIMMER LOCATION

Chassis 6C01 features a high gain tuned R.F. circuit ahead of a conventional superheterodyne circuit, with feedback in the audio circuit, and a new filter circuit to reduce hum to a minimum.

Part of the audio voltage from the voice coil is fed back to the first audio grid (12SQ7) in phase through resistor R10 and R7 to a tap on the volume control R6. Capacitor C15 bypasses highs to ground. One side of the output transformer secondary is grounded. The side grounded determines the phase relationship of the feedback voltage, therefore, when replacing the output transformer be certain the proper end of the secondary is grounded or degeneration will result. The overall result of this arrangement is to boost the base tones.

The filter circuits of chassis 6C01 incorporate new features that should be well understood by the service man. An examination of the schematic drawing will show the output transformer tapped slightly off center. This tap is the B+ connection from filter resistor R11 and capacitor C20 off the cathode of the rectifier 35Z5 to the 35L6 plate. The lower connection of the output transformer feeds B+ to the rest of the tubes in the receiver. Current flowing through the upper windings of the output transformer to the 35L6 produces a magnetic field which is 180° out of phase with the magnetic field produced by current flowing in the opposite direction through the output transformer to the rest of the receiver, therefore, most of the AC hum is cancelled. Further reduction of hum is accomplished by filtering through resistors R12 and R13 and capacitors C18 and C19.

This development in filtering systems allows a higher effective plate voltage on the 35L6 for increased power output.

MANUAL OF 1947 MOST-OFTEN-NEEDED RADIO DIAGRAMS

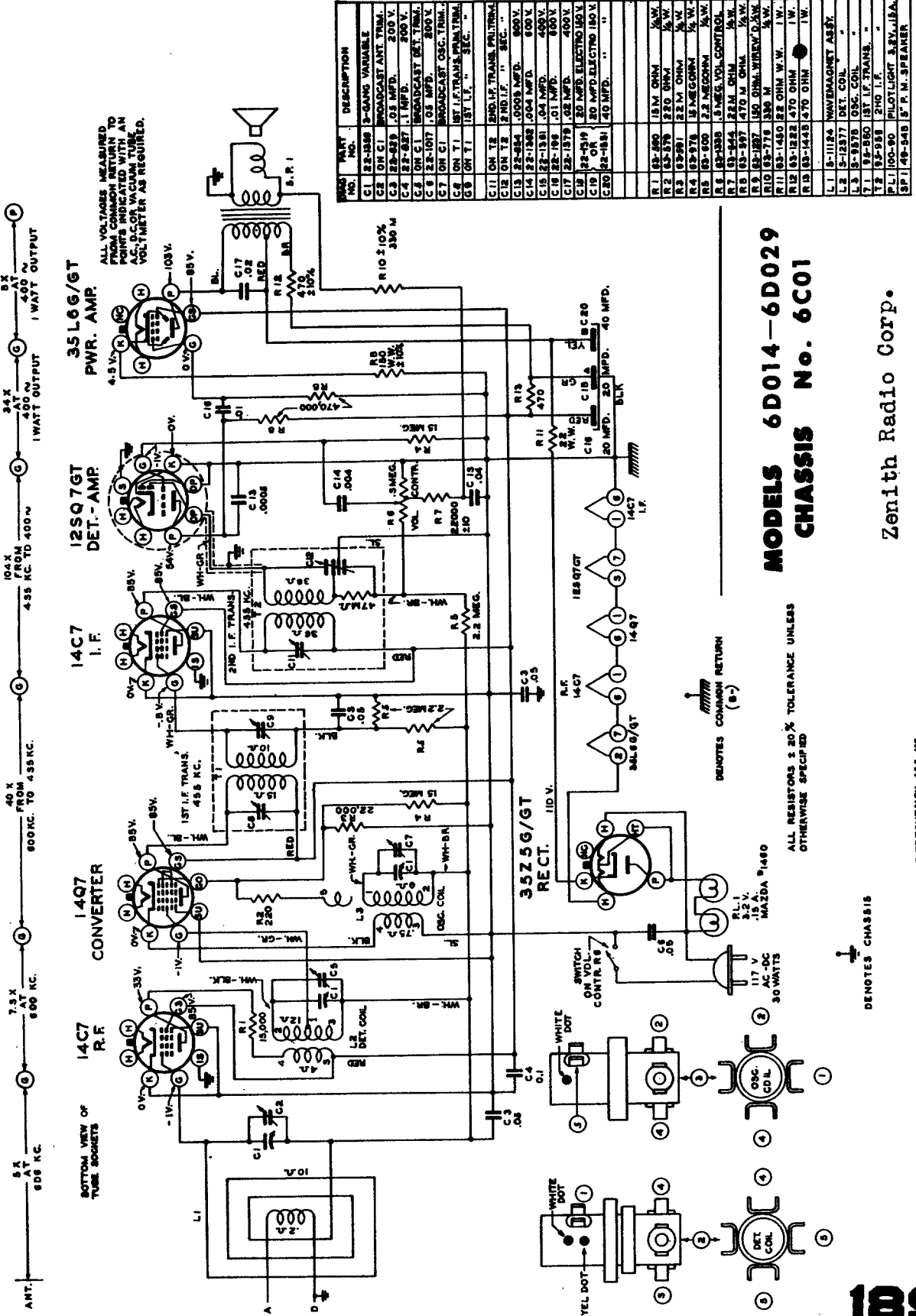

MODELS 6D014-6D029 CHASSIS No. 6C01

ALL RESISTORS ± 20% TOLERANCE UNLESS OTHERWISE SPECIFIED

⊕ DENOTES CHASSIS

I.F. FREQUENCY 455 KC. TUNING RANGE 550-1620 KC.

Zenith Radio Corp.

MANUAL OF 1947 MOST-OFTEN-NEEDED RADIO DIAGRAMS

Zenith Radio Corp.

MODELS 8H023 - 8H034

CHASSIS No. 8C01

Opera- tion	Connect Oscillator to	Dummy Antenna	Input Signal Frequency	Band	Set Dial To	Adj. Trimmers	Purpose
1	Pin 8 on Converter Tube 6SB7 Socket	.05 Mfd.	455 Kc. Modulated	BC	600 Kc.	L-11, 12, 15, 16, 19 and 20	Align I.F. channel for maximum output Adjust wavetrap for minimum output
2	Pin 1 on R.F. tube 6AG5 socket	.05 Mfd.	455 Kc. Modulated	BC	600 Kc.	C9	Set oscillator to dial scale
3	2 turns loosely cpld. to wavemagnet		1600 Kc. Modulated	BC	1600 Kc.	C18	
4	2 turns loosely cpld. to wavemagnet	.05 Mfd.	1400 Kc. Modulated	BC	1400 Kc.	C11 & C2	Align det. and ant. stages. Align primary of discriminator for maximum reading
5 (a)	Pin 4 (grid) on 6SH7 limiter socket	.05 Mfd.	8.3 Mc. Unmodulated	FM 45		I21 coil slug Primary discr.	Adjust secondary of discrim- inator for zero reading
6 (b)	Pin 4 (grid) on 6SH7 limiter socket	.05 Mfd.	8.3 Mc. Unmodulated	FM 45		I22 coil slug sec. of discr.	
7 (c)	Pin 4 (grid) on 6SH7 2nd IF tube socket	.05 Mfd.	8.3 Mc. Unmodulated	FM 45		L17 & L18 Prim. & Sec. of 3rd IF trans.	Align 3rd IF transformer for maximum reading
8 (c) (d)	Pin 4 (grid) on 6SG7 1st IF tube socket	.05 Mfd.	8.3 Mc. Unmodulated	FM 45		L13 & L14 primary and sec. of 2nd IF transformer	Align 2nd IF transformer for maximum reading
9 (c) (d)	Pin 8 (grid) on 6SB7 converter tube socket	.05 Mfd.	8.3 Mc. Unmodulated	FM 45		L9 & L10 Primary & Sec. of 1st IF transformer	Align 1st IF transformer for maximum reading
10 (c)	Antenna Post (Re- move line ant.)	270 ohms	98 Mc. Unmodulated	FM 100	98 Mc.	L7 Osc. Coil slug	Set oscillator to dial scale
11 (c)	Antenna Post (Re- move line ant.)	270 ohms	98 Mc. Unmodulated	FM 100	98 Mc.	L3 & L2 Det. and RF coil slugs	Align det. and ant. stages to maximum reading
12 (c)	Antenna Post (Re- move line ant.)	270 ohms	45 Mc. Unmodulated	FM 45	45 Mc.	C14	Set oscillator to dial scale
13 (c)	Antenna Post (Re- move line ant.)	270 ohms	45 Mc. Unmodulated	FM 45	45 Mc.	C15 & C6	Align detector & ant. stages for maximum reading

A vacuum tube voltmeter with an isolation resistor of 200,000 ohms in series with the hot lead will serve for FM adjustments. This lead should be shielded.

An AC output meter connected across the primary or secondary of the output transformer will be satisfactory for all AM adjustments.

The signal generator output should be kept just high enough to get an indication on the meter.

- (a) Vacuum Tube Voltmeter pin 5 on discriminator transformer to chassis (half discriminator load.)
- (b) Vacuum Tube Voltmeter pin 7 on discriminator transformer to chassis (full discriminator load.)
- (c) Vacuum Tube Voltmeter 6SH7 limiter grid (pin 4) to chassis.
- (d) 300 ohm 1/2 watt carbon resistor soldered across the secondary L14 (pin 2 and 3 of 2nd, IF trans.). The leads to the resistor must be as short as possible and the resistor removed before operation 10 is started.

**MODELS 8H023 - 8H034
CHASSIS No. 8C01**

Zenith Radio Corp.

The 8C01 chassis incorporates a superheterodyne circuit with two stages of IF, and one stage of RF amplification on all bands.

When adjustments are made on the 8C01 or any AC-DC chassis, a line isolation transformer (110 V input to 110 V output) is recommended in order to avoid a "hot" chassis. If an isolation transformer is not available, check the AC voltage between chassis and bench ground, and if there is any indication of voltage, reverse the plug before handling the set.

AM Alignment: The alignment of this chassis on the standard broadcast band is conventional. The alignment slugs in the IF transformers are threaded and screw into the coil forms. The slugs are slotted for a small size fiber screw driver. Do not press hard on the aligning tool (fiber screw driver) or the threads in the coil forms will strip and adjustment will be impossible.

FM RF Alignment: The same coil slug arrangement which tunes the 100 MC FM band also tunes the 45 MC band. However, tuning slugs are attached to threaded shafts and the slugs are varied in the field of the coils by turning the shafts clockwise or counter-clockwise. After adjustments the shafts must be secured with a drop of speaker cement.

FM IF Alignment: The same type of tuning slugs for aligning the AM IF Amplifier are used for the FM I.F.'s. Observe the same precautions when making adjustments. When an overcoupled stage is aligned with an unmodulated signal, the stage must be band pass with good sensitivity. The second 8.3 Mc If stage is aligned with an unmodulated signal, the stage must be loaded. A 300 ohm carbon resistor soldered across the secondary of the second IF transformer provides a satisfactory load for this circuit. The resistor leads must be kept short to reduce the distributed capacity of the circuit.

When aligning a loaded stage, it will be found that considerable signal from the generator will be required, and that it will tune broadly. **THE LOAD RESISTOR MUST BE REMOVED AFTER ALIGNMENT.**

If the signal generator used does not have sufficient output to overcome the temporary loss caused by the load resistor, the load resistance may be increased or the signal fed into the preceding stage.

FM Discriminator Alignment: When the secondary of the discriminator is aligned (operation 6) use sufficient signal input to get a good positive and negative indication before setting the slug for zero reading. A center zero indicating meter is recommended for this adjustment, but is not absolutely necessary. Reversing the leads of a non-zero center meter, or observing closely when this meter starts to go to the left (negative) of zero will give the same results.

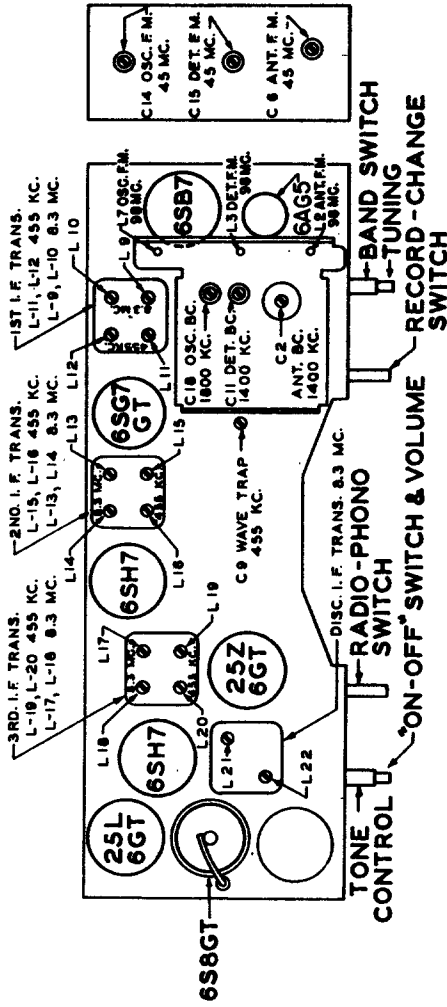

TUBE AND TRIMMER LOCATION