

Most - Often - Needed

1950

RADIO

DIAGRAMS

and Servicing Information

Compiled by

M. N. BEITMAN

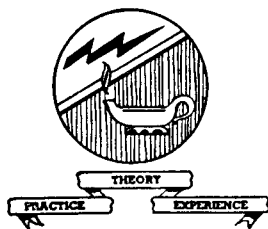

SUPREME PUBLICATIONS
CHICAGO

MANUAL OF 1950 MOST-OFTEN-NEEDED RADIO DIAGRAMS

Index

Always use this complete Index to find the service data on the radio you are servicing. The various makes of radios are listed in alphabetical order by manufacturer's name. Under each make, models are listed in numerical order at the left of the column while the corresponding page numbers are given on the right.

Admiral Corp.		Buick		Emerson Radio	
4R1	6	980782	163	577	34
4R11	6	980899	164	579	33
4R12	6			581	35
6A2	7	Chevrolet		586	36-37
6A21	7	986240	24	590	38
6A22	7	986241	24	591	39
6A23	7	986388	24	594	35
6Q1	8	986389	24	595	35
6Q11	8			596	33
6Q12	8	Coronado		599	40
6Q13	8	05RA1-43-7755A	52	600	41
6Q14	8	94RA1-43-8510B	52	601	40
6S1	9	94RA1-43-8511B	52	602	41
6S11	9			605	42-43
6S12	9			613	46
6W1	10	Crosley Corp.		616	41
6W11	10	10-102E	26	623	38
6W12	10	10-103	26	636	47
6Y1	11	10-104W	26	640	48
6Y18	11	10-135	28	642	45
6Y19	11	10-136E	28	645	49
9E1	12-15	10-137	28	652, 653	44
9E15	12-15	10-138	28	656B, 657B	50
9E16	12-15	10-139	28	120012B	34
9E17	12-15	10-140	28	120023B	36-37
RC400	16-23	10-145M	29	120032B	44
Changer	16-23	10-307M	30	120034A	33
		10-310	27	120055A	39
Airline		10-311	27	120071A	35
see Montgomery W.		10-313	27	120072A	41
		58XTA	25	120075B	40
Arvin		58XTW	25	120076B	42-43
RE-260	97-98			120080B	44
RE-273	99	Delco		120082A	41
RE-274	96	see United Motors		120083B	36-37
RE-278	100			120085A	46
341T	96	DeWald Radio Mfg.		120101A, -B	38
356T	99	D-508	32	120106A	47
357T	99	D-616	32	120112	48
360TFM	97-98	C-800	31	120115	49
361TFM	97-98			120117A	45
440T	100			120122B	50

MANUAL OF 1950 MOST-OFTEN-NEEDED RADIO DIAGRAMS

Firestone Tire	
4-B-31	51
Gamble-Skogmo	
05RA1-43-7755A	52
94RA1-43-8510B	52
94RA1-43-8511B	52

General Electric	
4SJ2A1	53
4SJ3A1	53
4SJ4A1	53
64 to 67	61
123	55
124	55
125	55
129	54
131	54
135	55
136	55
143	62
145	56
165	57
186-3A	53
218	58-59
218H	58-59
226	60
500	61
501	61
505 to 509	61
530	61
600	62
601	62
603	62
604	62
650	57

Hudson Motor Car	
6E89	192
6MH889	192

Montgomery Ward	
05WG-1811B	65
05WG-2745B	66
05WG-2752	63
84BR-1517A	67
84HA-1527A	68
84HA-1528A	68
94WG-1059A	69
94WG-2745A	66
1059A	69
1517A	67
1518A	67
1527A	68
1528A	68
1811B	65

Mont. Ward, cont.	
2745	66
2748	63-64
2749	63-64
2751	63-64
2752	63-64

Motorola, Inc.	
5A9B, -M, -S	71
5A9UB, -UM	71
5J1, 5J1U	80
5L1, 5L1U	80
5M1, 5M1U	80
5M2, 5M2U	80
CT9	92
CT10	92
RC-36	81-90
49L11Q	76
49L13Q	76
58R11A to -16A	77
59H11	78
59H12I	78
59L11Q	79
59L12Q	79
59L14Q	79
59R11	72
59R12I	72
59R13M	72
59R14E	72
59R15G	72
59R16Y	72
HS-62A	71
69L11	74
69X11	75
69X12 I	75
79FM21	73
79XM21	73
79XM22	73
HS-165	71
HS-167	72
HS-168	73
HS-175	74
HS-178	73
HS-181	75
HS-183	76
HS-184	77
HS-187	79
HS-206	78
HS-223	80
HS-224	80
HS-249	80
HS-250	80
309	91
400	91
409	93
500	94

Motorola, cont.	
600	95
700	70
Changer	81-90

Noblitt-Sparks	
RE-260	97-98
RE-273	99
RE-274	96
RE-278	100
341T	96
356T	99
357T	99
360TFM	97-98
361TFM	97-98
440T	100

Oldsmobile	
982544	166
982573	166

Philco Corp.	
M-20	111-118
50-522, -I	102
50-524	102
50-526	102
50-620	103
50-621	101
50-920	105
50-921	105
50-922	105
50-925	104
50-926	104
50-1420	106
50-1421	106
50-1422	106
50-1423	106
50-1424	107
50-1718	108
51-631	110
51-934	109
Changer	111-118

Pontiac	
984570	165

R.C.A. Victor	
BX6	119
7Q51X	120
8B41	122
8B42	122
8B43	122
8BX5	121
8BX54	121
8BX55	121
9BX5	121
9BX56	123
9EY3	127

MANUAL OF 1950 MOST-OFTEN-NEEDED RADIO DIAGRAMS

R.C.A. (continued)

9EY31	127
9EY32	127
9EY35	127
9EY36	127
9W106	131-132
9X561	124
9X562	124
9X571	125
9X572	125
9X641	125
9X642	125
9X651	126
9X652	126
9Y7	128
9Y51	129
BX55	130
Al06	131-132
RS-132	127
RP-168	133-144
RC-622	131-132
RC-1055D	120
RC-1057B	128
RC-1059A	121
RC-1059B, -C	121
RC-1068	123
RC-1069, -A, -B	122
RC-1077	129
RC-1079, -A	125
RC-1079B, -C	124
RC-1080, -A	125
RC-1082	119
RC-1085, -A	126
RC-1088	130
Changer	133-144

Sears, Roebuck

1	147
2	147
18	145-146
20	145-146
9022	145
9073	148
9105	145
132.871	145
132.875	145
132.877	145-146
132.878	147
135-244	148

Sentinel Radio

1U-312PG	149
1U-312PW	149
1U-335PG	154
1U-335PI	154
1U-335PM	154
1U-335PW	154

Sentinel (continued)

1U-339-K	155
312PG	149
312PW	149
331-I, -R, -W	150
332-I, -W	151
333-I, -W	152-153
335PG	154
335PI	154
335PM	154
335PW	154
339-K	155

Silvertone

see Sears, Roebuck

Sonora Radio

299	156
300	156
306	156

Stewart-Warner

9151-A	157-159
9152-A, -B, -C	160

Stromberg-Carlson

1500	161
------	-----

Traveler Radio

5015	162
5044	162

Truetone

see Western Auto

United Motors

980782	163
980899	164
982544	166
982573	166
984570	165

Western Auto

4B115	167
5D127	167
25D26-002	168
25D26-006	168
26A94-852	169
227A96-906	170
D-1946	169
D-2002	167
D-2003	167
D-2004	167
D-2017	168
D-2018	168
D-2027A	170

Westinghouse Elect.

H-198	171
H-199	172
H-210	173
H-211	173
H-300T5	175
H-301T5	175
H-302P5	174
H-303P4	176
H-304P4	176
H-305C8	177-178
H-306C8	177-178
H-310T5, -U	179
H-311T5, -U	179
H-312P4, -U	180
H-313P4, -U	180
V-2137-1	172
V-2137-2	171
V-2137-4	177-178
V-2144	173
V-2144-1	173
V-2148	175
V-2151-1	174
V-2153	176
V-2153-1	180
V-2161, -U	179

Zenith Radio Corp.

5G01	181
5G02	181
5G03	182
5G41	183
6E89	192
6G01	184
6G05	185
6MH889	192
7F01	188
7F02	186-187
7F04	186-187
7G01	188
7G02	189
7H-921	186-187
7H-922	186-187
8G20	190-191
8G21	190-191
G503	183
G510	181
G511	181
G516	182
G615	185
G660	184
G663	184
G665	184
G724	189
G725	188
G844	190-191
G881 to G885	190

MANUAL OF 1950 MOST-OFTEN-NEEDED RADIO DIAGRAMS

Admiral

CHASSIS 4R1
MODELS 4R11, 4R12

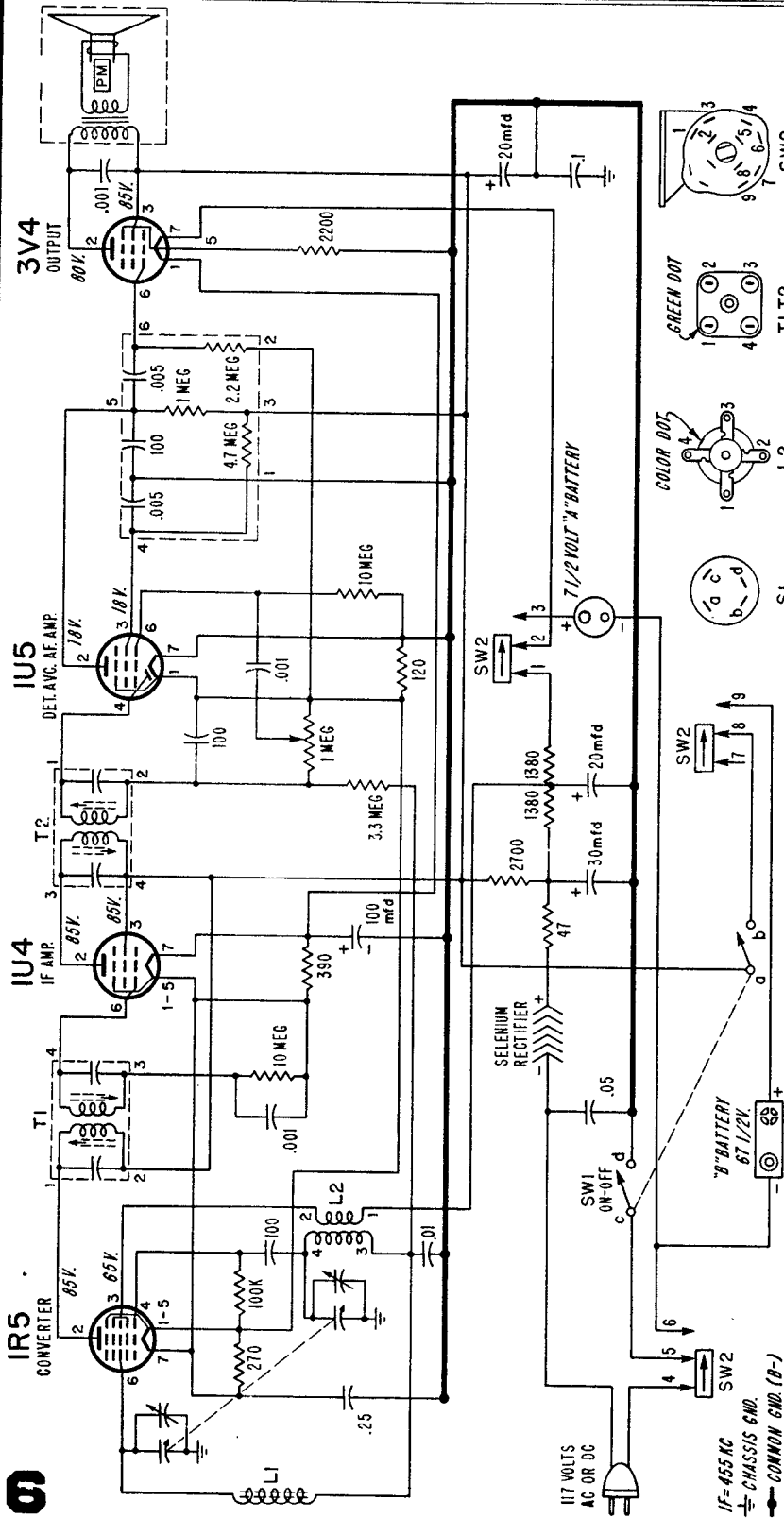

SW2 SHOWN IN POSITION FOR OPERATION FROM POWER LINE

VOLTAGE DATA

- All voltages taken between tube socket terminals and B minus (pin 7 of IU5 tube).
- Dial turned to low frequency end; volume control at minimum.
- Voltages measured with Vacuum Tube Voltmeter from 117 Volts AC line.

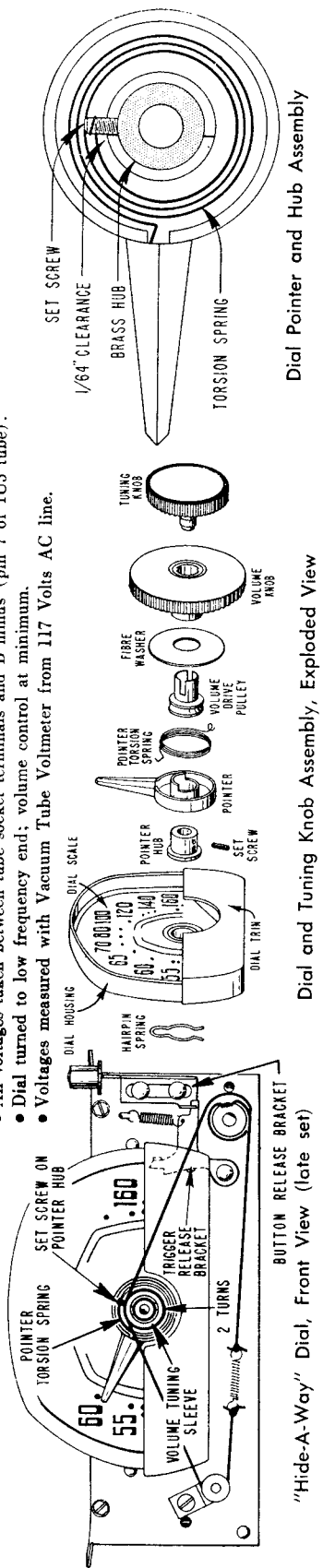

Dial Pointer and Hub Assembly

Dial and Tuning Knob Assembly, Exploded View

'Hide-A-Way' Dial, Front View (late set)

MANUAL OF 1950 MOST-OFTEN-NEEDED RADIO DIAGRAMS

Admiral

CHASSIS 6A2 MODELS 6A21, 6A22, 6A23

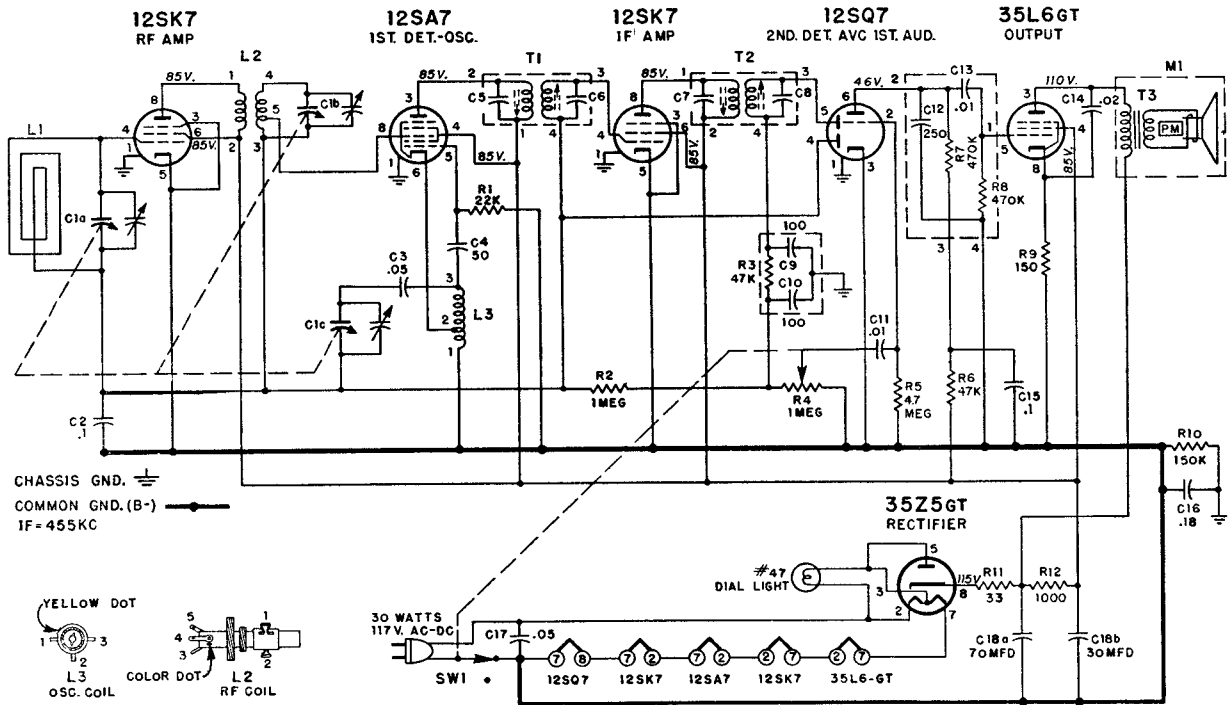

ALIGNMENT PROCEDURE

- Turn receiver volume control full on.
- Use an isolation transformer if available, otherwise connect a .1 mfd. condenser in series with low side of signal generator and connect to B minus (terminal of On-Off switch).
- Connect output meter across speaker voice coil.
- Use lowest output setting of signal generator capable of producing adequate output meter indication and then proceed as outlined in chart below.
- Repeat adjustments to insure good results.
- Use a non-metallic alignment tool for IF transformers.

TUBE AND TRIMMER LOCATION

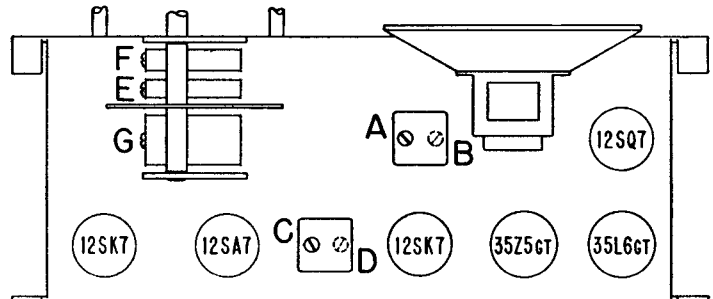

Adjustments B and D are made from underside of chassis.

Step	Dummy Antenna in Series with Signal Generator	Connection of Signal Generator (High Side)	Signal Generator Frequency	Receiver Gang Setting	Trimmer Description	Trimmer Designation	Type of Adjustment
1	250 mmfd. condenser	Pin 8 of 12SA7 tube	455 KC	Gang fully open	2nd IF 1st IF	A, *B C, *D	Maximum Output
2	250 mmfd. condenser	Tuning condenser Antenna stator	1620 KC	"	Oscillator (on gang)	E	"
3	Loop of several turns of wire (or place generator lead close to receiver loop for adequate signal)	No physical connection (signal by radiation)	1400 KC	Tune in Generator signal	RF (on gang)	F	"
4	"	"	"	"	Antenna (on gang)	G	"

*Adjustments B and D are made from underside of chassis.

MANUAL OF 1950 MOST-OFTEN-NEEDED RADIO DIAGRAMS

Admiral

CHASSIS 6Q1
MODELS 6Q11, 6Q12, 6Q13, 6Q14

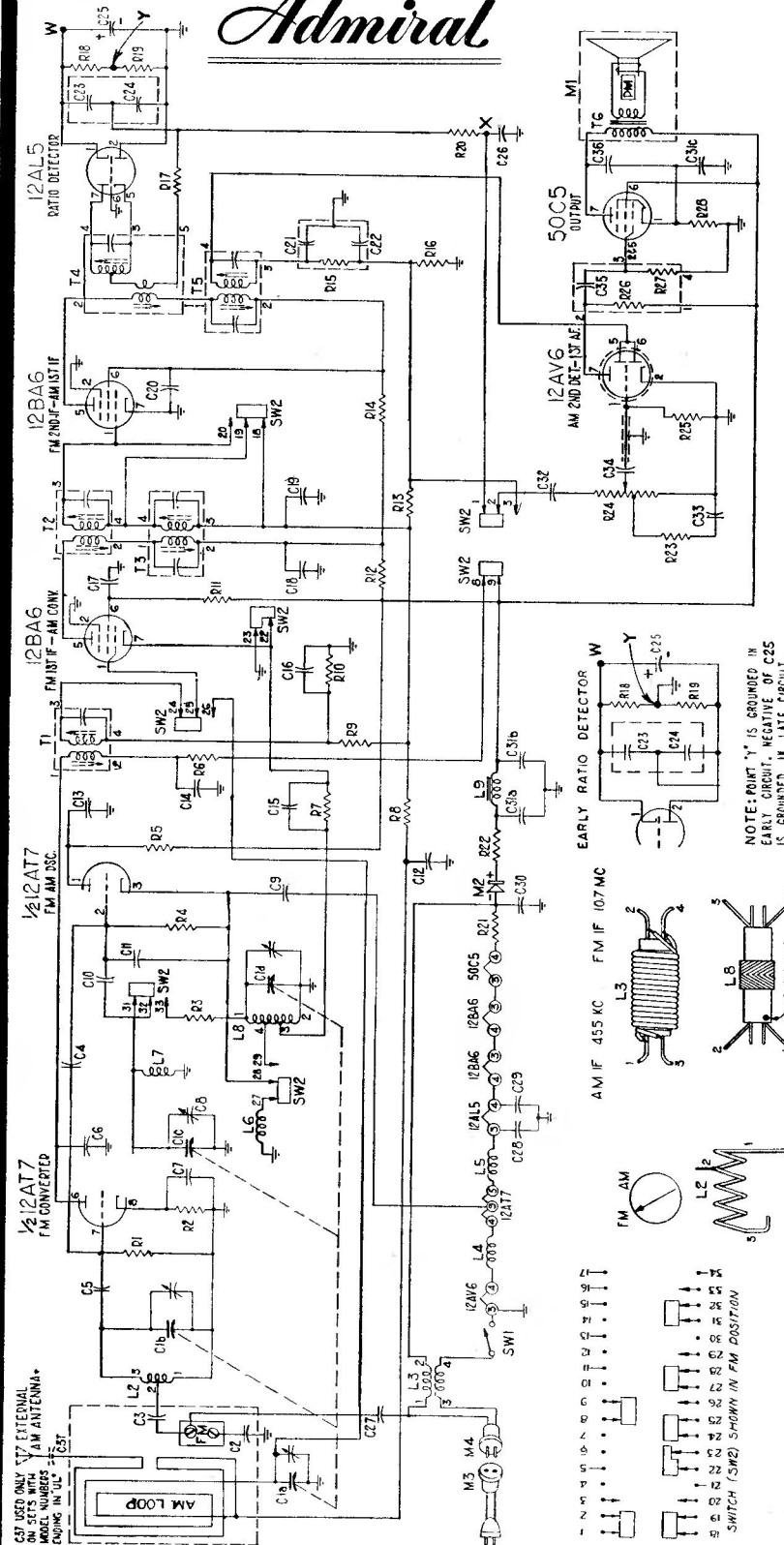

37 USED ONLY ON SETS WITH AM ANTENNA* MODEL NUMBERS ENDING IN "UL" †38

* Part of enclosed couplate unit (part number 63A5-2). Replace with exact duplicate part or individual components.
 † Part of enclosed diode filter unit (part number 63A3-1). Replace with exact duplicate part or individual components.

RESISTORS

Symbol	Description	Part No.
R1	1 megohm, 1/2 watt	60B 8-105
R2	100 ohms, 1/2 watt	60B 8-101
R3	1000 ohms, 1/2 watt	60B 8-102
R4	22,000 ohms, 1/2 watt	60B 8-223
R5	470 ohms, 1/2 watt	60B 8-471
R6	470 ohms, 1/2 watt	60B 8-471
R7	1000 ohms, 1/2 watt	60B 8-102
R8	1 megohm, 1/2 watt	60B 8-105
R9	1 megohm, 1/2 watt	60B 8-105
R10	220,000 ohms, 1/2 watt	60B 8-224
R11	1000 ohms, 1/2 watt	60B 8-102
R12	1000 ohms, 1/2 watt	60B 8-102
R13	1 megohm, 1/2 watt	60B 8-105
R14	1000 ohms, 1/2 watt	60B 8-102
*R15	47,000 ohms, 1/4 watt	60B 8-474
R16	470,000 ohms, 1/2 watt	60B 8-474
R17	390 ohms, 1/2 watt	60B 8-391
R18	15,000 ohms, 5%, 1/2 watt	60B 7-153
R19	15,000 ohms, 5%, 1/2 watt	60B 7-153
R20	27,000 ohms, 1/2 watt	60B 8-273
R21	47 ohms, 1 watt	60B 14-470
R22	33 ohms, 1 watt	60B 14-330
R23	18,000 ohms, 1/2 watt	60B 8-183
R24	1 megohm Volume Control (tapped at 500,000 ohms)	75B 2-14
R25	10 megohms, 1/2 watt	60B 8-106
*R26	500,000 ohms, 1/4 watt	60B 8-106
*R27	500,000 ohms, 1/4 watt	60B 8-106
R28	150 ohms, 1 watt	60B 14-151

CONDENSERS

C1a	485.8 mmfd, (max) AM RF	Gang	
C1b	15 mmfd, (max) FM RF		68B 27
C1c	15 mmfd, (max) FM Osc.		
C1d	142.6 mmfd, (max) AM Osc.		
(Dial drum welded to gang)			
C2	.01 mfd, 400 volts, Paper	64B 1-25	
C3	.0015 mfd, "Hi-K" Ceramic	65B 9-63	
C4	68 mmfd, Ceramic	65A 16-1	
C5	.001 mfd, "Hi-K" Ceramic	65B 9-31	
C6	65 mmfd, 3%, Silver Mica	65B 1-27	
C7	.001 mfd, "Hi-K" Ceramic	65B 9-31	
C8	3 to 12 mmfd, trimmer, Silver Ceramic	66A 19-2	
C9	35 mmfd, Zero Temp. Coeff., Ceramic	65B 6-57	
C10	50 mmfd, Ceramic	65B 6-4	
C11	2 mmfd, ± .25 mmfd, -00075 Temp. Coeff., Ceramic	65B 6-58	
C12	.01 mfd min., Ceramic	65A 10-3	
C13	.005 mfd min., Ceramic	65A 10-1	
C14	.01 mfd min., Ceramic	65A 10-3	
C15	.005 mfd min., Ceramic	65A 10-1	
C16	.01 mfd min., Ceramic	65A 10-3	
C17	.01 mfd min., Ceramic	65A 10-3	
C18	.01 mfd min., Ceramic	65A 10-3	
C19	.01 mfd min., Ceramic	65A 10-3	
C20	.01 mfd min., Ceramic	65A 10-3	
*C21	100 mmfd, Ceramic		
*C22	100 mmfd, Ceramic		
C23	100 mmfd 10%		
C24	100 mmfd 10%	Dual Ceramic. 63A 7-1	
C25	4 mfd, 50 volts, Elect.	67A 4-8	
C26	.002 mfd, 600 volts, Paper	64B 1-14	
C27	35 mmfd, Zero Temp. Coeff., Ceramic	65B 6-57	
C28	.01 mfd min., Ceramic	65A 10-3	
C29	.01 mfd min., Ceramic	65A 10-3	
C30	.05 mfd, 200 volts, Paper	64B 1-32	
C31a	70 mfd, 150 volts	Elect.	
C31b	30 mfd, 150 volts		
C31c	20 mfd, 25 volts	67C 7-14	
C32	.005 mfd min., Ceramic	65A 10-1	
C33	.01 mfd min., Ceramic	65A 10-3	
C34	.005 mfd min., Ceramic	65A 10-1	
*C35	.005 mfd, Ceramic		
C36	.002 mfd, 600 volts, Paper	64B 1-14	
C37	.01 mfd, 400 volts, Paper	64B 1-25	
(C37 used only in sets with model numbers ending in "UL".)			

COILS, TRANSFORMERS, ETC.

L1	Antenna, Loop (AM)	69C 97
L2	Coil, Antenna (FM)	69A 103
L3	Coil, Line Cord (FM antenna)	69A 102
L4	Coil, RF Choke (FM antenna)	73A 6-2
L5	Coil, RF Choke	73A 6-2
L6	Coil, RF Choke	73A 6-2
L7	Coil, Oscillator (FM)	69A 104
L8	Coil, Oscillator (AM)	69A 105-1
L9	Choke, Filter (2.5 Henry)	74A 15-2
T1	Transformer, 1st IF (FM)	72B 89
T2	Transformer, 2nd IF (FM)	72B 90
T3	Transformer, 1st IF (AM)	72B 91
T4	Transformer, Ratio Detector	72B 39
T5	Transformer, 2nd IF (AM)	72B 74
T6	Transformer, Speaker Output	98A 4
M1	Speaker and Output Transformer (5" PM)	78B 42-2

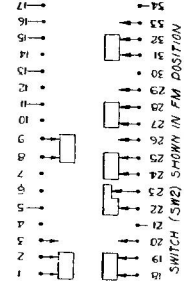

MANUAL OF 1950 MOST-OFTEN-NEEDED RADIO DIAGRAMS

Admiral

CHASSIS 6S1 MODELS 6S11, 6S12

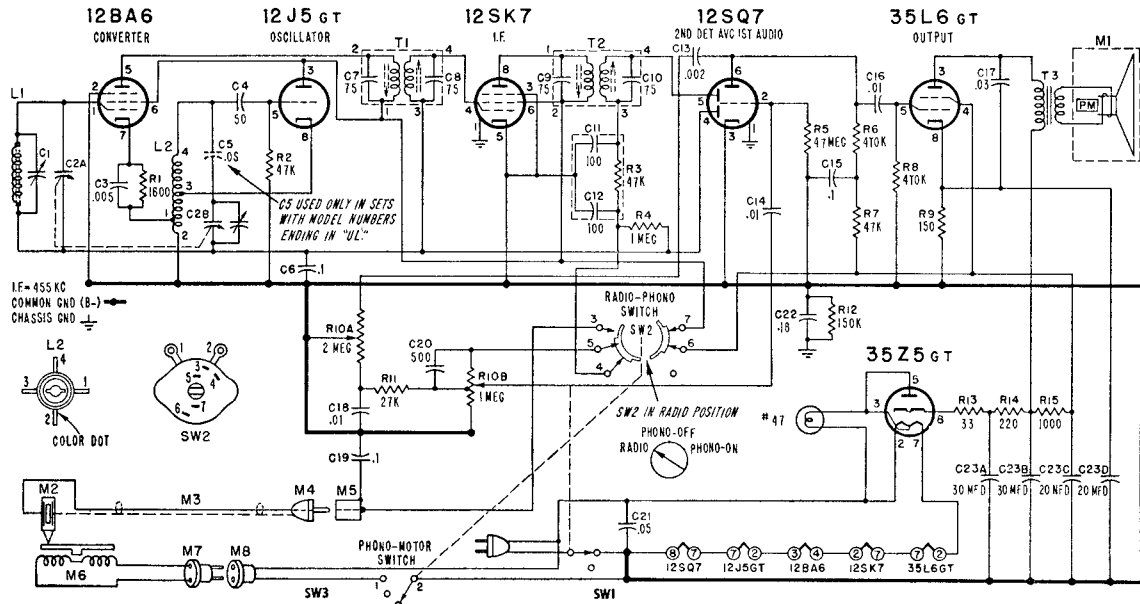

TUBE AND TRIMMER LOCATION

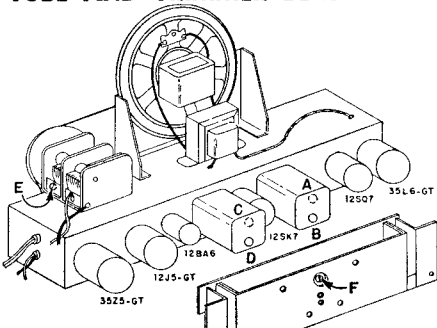

VOLTAGE DATA

- All readings made between tube socket terminals and B minus (terminal of On-Off switch).
- Range Switch in "Radio" position.
- Measured on 117 Volt AC line.
- Volume control minimum; dial turned to low end.
- Voltages measured with Vacuum Tube Voltmeter.

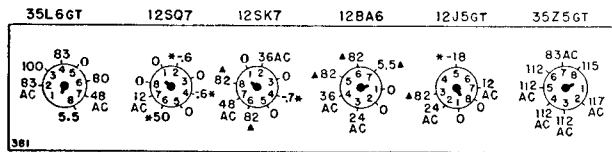

* If taken with a 1000 ohm-per-volt meter, readings will be either lower or practically zero.
 ▲ On "Phono" these voltages will be zero. All other DC readings may be slightly higher.

Step	Dummy Antenna in Series with Signal Generator	Connection of Signal Generator (High Side)	Signal Generator Frequency	Receiver Gang Setting	Trimmer Description	Trimmer Designation	Type of Adjustment
1	250 mmfd. condenser	Tuning condenser, antenna stator	455 KC	Gang fully open	2nd IF 1st IF	*A, B *C, D	Maximum output
2	250 mmfd. condenser	Tuning condenser, antenna stator	1620 KC	Gang fully open	Oscillator	E	Maximum output
3	Loop of several turns of wire, or place generator lead close to receiver antenna for adequate signal.	No actual connection (signal by radiation)	1400 KC	Tune in generator signal	Antenna	†F	Maximum output

*Adjustments A and C made from the top of the chassis. If IF transformers have hollow core slugs, these adjustments may all be made from the top of chassis, if you use alignment tool #98A30-7 obtainable from your Admiral distributor. The bottom IF slug adjustment may be reached through the hollow core in the upper slug.

† Antenna Trimmer "F" should be aligned after chassis and antenna are mounted in cabinet.

MANUAL OF 1950 MOST-OFTEN-NEEDED RADIO DIAGRAMS

Admiral

**CHASSIS 6W1
MODELS 6W11, 6W12**

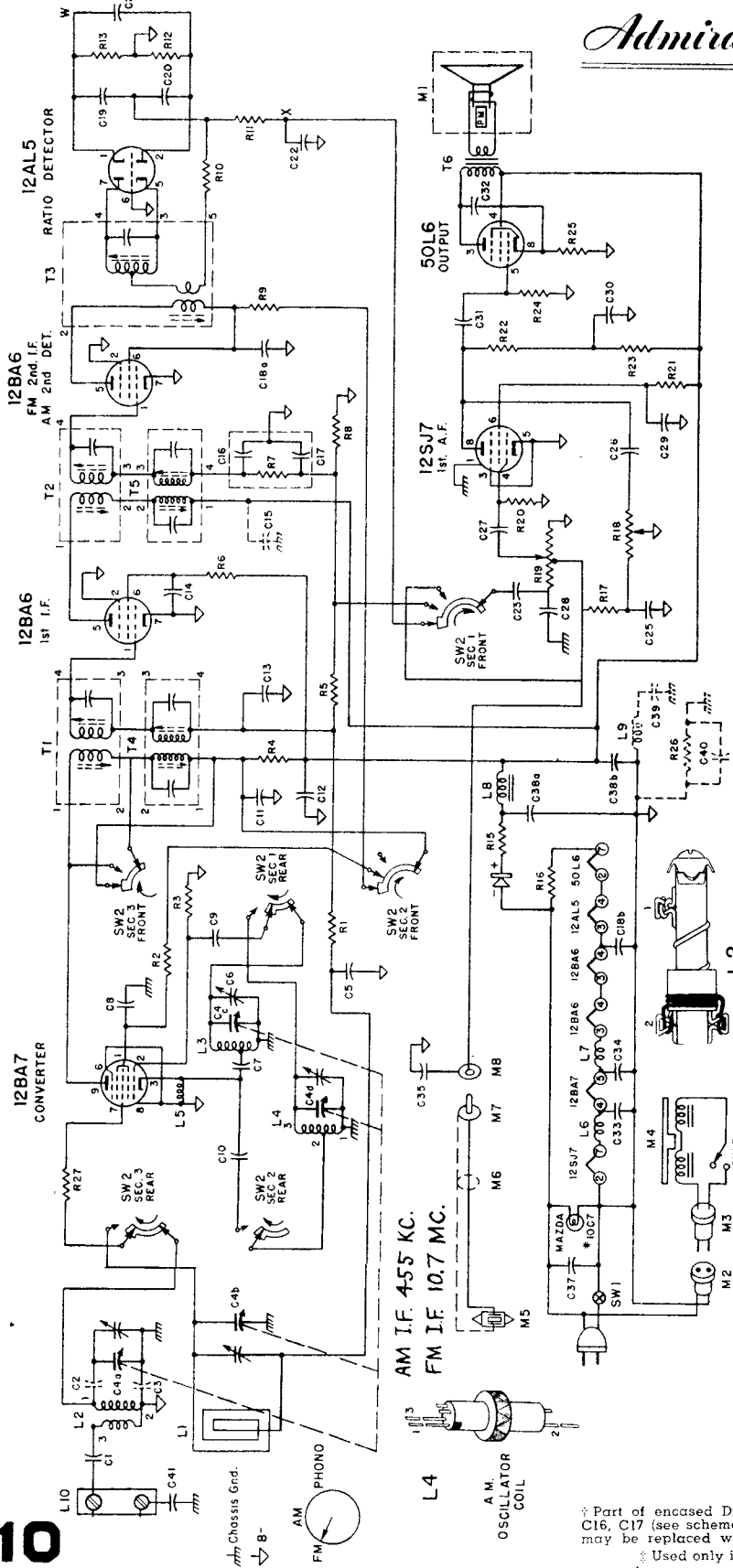

RESISTORS

Symbol	Description	Part No.
R1	470,000 Ohms, 1/4 Watt	60B 2-474
R2	1,000 Ohms, 1/4 Watt	60B 2-102
R3	22,000 Ohms, 1/4 Watt	60B 2-223
R4	470 Ohms, 1/4 Watt	60B 2-471
R5	470,000 Ohms, 1/4 Watt	60B 2-474
R6	1,000 Ohms, 1/4 Watt	60B 2-102
R7	47,000 Ohms, 1/4 Watt	60B 2-224
R8	220,000 Ohms, 1/4 Watt	60B 2-102
R9	1,000 Ohms, 1/4 Watt	60B 2-102
R10	390 Ohms, 1/4 Watt	60B 2-391
R11	27,000 Ohms, 1/4 Watt	60B 2-273
R12	6,800 Ohms, 1/4 Watt, 5%	60B 1-682
R13	6,800 Ohms, 1/4 Watt, 5%	60B 1-682
R15	33 Ohms, 1 Watt	60B 14-330
R16	47 Ohms, 1 Watt	60B 14-470
R17	27,000 Ohms, 1/4 Watt	60B 2-273
R18	2 Megohms Tone Control and ON/OFF Switch SW1 (Tapped at 500,000 Ohms)	75B 1-12
R19	1 Megohm Volume Control (Tapped at 500,000 Ohms)	75B 2-12
R20	4.7 Megohms, 1/4 Watt	60B 3-475
R21	1.8 Megohms, 1/4 Watt	60B 3-185
R22	470,000 Ohms, 1/4 Watt	60B 2-474
R23	47,000 Ohms, 1/4 Watt	60B 2-473
R24	470,000 Ohms, 1/4 Watt	60B 2-474
R25	150 Ohms, 1/2 Watt	60B 8-151
R26	150,000 Ohms, 1/2 Watt	60B 2-154
R27	10 Ohms, 1/4 Watt	60B 2-100

CONDENSERS

C1	200 mmfd., Ceramic	65B 9-15
C2	0015 mfd., Ceramic	65B 9-63
C3	005 mfd. min., Ceramic	65A 10-1
C4a	15 mmfd. (max.) FM RF	
C4b	485.8 mmfd. (max.) AM RF	A1814
C4c	15 mmfd. (max.) FM Osc.	
C4d	142.6 mmfd. (max.) AM Osc. (Drum spot welded to gang)	Gang
C5	.01 mfd., 400 Volts, Paper	64B 1-25
C6	3-12 mmfd. Trimmer, Ceramic	66A 19-2
C7	50 mmfd., Ceramic	65B 6-4
C8	.005 mfd. min., Ceramic	65A 10-1
C9	35 mmfd., 10% Zero Temp. Coeff., Ceramic	65B 6-57
C10	.005 mfd. min., Ceramic	65A 10-1
C11	.005 mfd. min., Ceramic	65A 10-1
C12	.005 mfd. min., Ceramic	65A 10-1
C13	.005 mfd. min., Ceramic	65A 10-1
C14	.01 mfd. min., Ceramic	65A 10-3
C15	.005 mfd. min., Ceramic	65A 10-1
C16	100 mmfd., Ceramic	65A 10-1
C17	100 mmfd., Ceramic	
C18a	.004 mfd. min. } Dual Ceramic	65A 17-1
C18b	.004 mfd. min. }	
C19	100 mmfd., 5%, -.00075 Temp. Coeff., Ceramic	65B 6-7
C20	100 mmfd., 5%, -.00075 Temp. Coeff., Ceramic	65B 6-7
C21	4 mfd., 50 Volts, Elect.	67A 4-8
C22	.002 mfd., 600 Volts, Paper	64B 1-14
C23	.001 mfd., Ceramic	65B 9-31
C25	.005 mfd., 600 Volts, Paper	64B 1-12
C26	.002 mfd., 600 Volts, Paper	64B 1-14
C27	.01 mfd., 400 Volts, Paper	64B 1-25
C28	50 mmfd., Ceramic	65B 6-4
C29	.1 mfd., 200 Volts, Paper	64B 1-30
C30	.1 mfd., 200 Volts, Paper	64B 1-30
C31	.01 mfd., 400 Volts, Paper	64B 1-25
C32	.01 mfd., 400 Volts, Paper	64B 1-25
C33	.0015 mfd. min., Ceramic	65A 14-2
C34	.0015 mfd. min., Ceramic	65A 14-2
C35	.01 mfd., 400 Volts, Paper	64B 1-25
C37	.05 mfd., 200 Volts, Paper	64B 1-32
C38a	70 mfd., 150 Volts } Elect.	67C 6-40
C38b	30 mfd., 150 Volts }	
C39	.1 mfd., 200 Volts, Paper	64B 1-30
C40	.01 mfd. min., Ceramic	65A 10-3
C41	.0015 mfd. min., Ceramic	65A 14-2

(Used only in sets with model numbers ending in "N".)

COILS, TRANSFORMERS, ETC.

L1	Antenna, Loop (AM)	69B 73
L2	Coil, RF (FM)	69A 68
L3	Coil., Oscillator (FM)	69A 69
L4	Coil, Oscillator (AM)	69A 20-3
L5	Choke, Cathode RF	AA139-5
L6	Choke, Heater RF	73A 2-3
L7	Choke, Heater RF	73A 2-3
L8	Choke, Filter	74A 15-2
L9	Coil, IF Trap	
Approx. 5 turns (18") of solid No. 22 hook-up wire wound on C39. Solder one end to inside foil lead of C39.		
L10	Antenna, Built in FM.	AB155

† Part of enclosed Diode Filter Unit 63A3-1. This unit consists of R7, C16, C17 (see schematic). If a section of the unit becomes defective, it may be replaced with a component of proper value.

‡ Used only in sets with model numbers ending in "UL".

MANUAL OF 1950 MOST-OFTEN-NEEDED RADIO DIAGRAMS

REPLACEMENT OF BATTERY PACK

Replace A-B battery pack with Ensign type AB50 pack, Ray-O-Vac AB994, General 60A-6F6-5, Burgess F6A60 or other equivalent.

Electrical characteristics of the recommended battery packs provide for equal life for both the A and B sections. The A section may give satisfactory performance as low as 6.6 volts, the B section as low as 60 volts. Replace battery pack when reception is weak and voltage has dropped below values given above.

To install a replacement battery pack, merely open the back of the cabinet, pull out the battery plug and slide out the run-down battery pack.

Slip a new battery pack into place, plug in the battery plug.

- Voltage readings taken between tube socket terminals and B minus (metal shell of electrolytic condenser), unless otherwise shown.
- Dial set to low frequency, no signal, and volume control minimum.
- Measurements made from 117 volts AC line. If measured from DC line, voltages may be slightly lower.
- Voltage readings taken with a vacuum tube voltmeter. Socket terminals marked with an asterisk * indicate much lower voltage or zero voltage if measured with a 1000 ohm-per-volt meter.
- If measurements are made on battery operation, tube filament and B plus voltages will vary with the condition of the batteries. These voltages will equal the terminal voltage of the A or B battery less the voltage drop through components.

Admiral

CHASSIS 6Y1
MODEL 6Y18, 6Y19

TUBE AND TRIMMER LOCATION

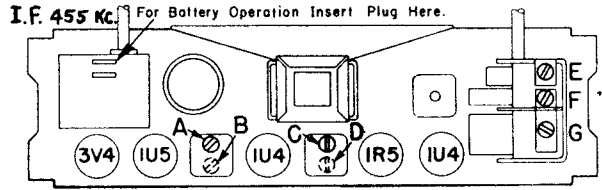

VOLTAGE DATA

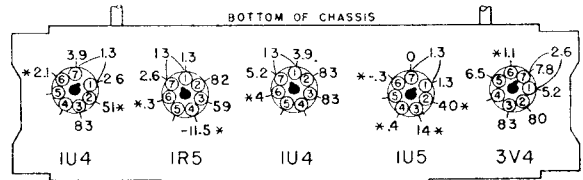

*If taken with a 1000 ohm-per-volt meter, readings will be lower or zero.

RESISTORS

Symbol	Description	Part No.
R1	2.2 Megohms, 1/2 Watt	60B 8-225
R2	27,000 Ohms, 1/2 Watt	60B 8-273
R3	1 Megohm, 1/2 Watt	60B 8-105
R4	100,000 Ohms, 1/2 Watt	60B 8-104
R5	8,200 Ohms, 1/2 Watt	60B 8-822
R6	3.3 Megohms, 1/2 Watt	60B 8-335
R7	10 Megohms, 1/2 Watt	60B 8-106
R8	1 Megohm, Volume Control and On-Off Switch	75B 1-26
R9	4.7 Megohms, 1/2 Watt	60B 8-475
R10	470,000 Ohms, 1/2 Watt	60B 8-474
R11	2.2 Megohms, 1/2 Watt	60B 8-225
R12	5.6 Megohms, 1/2 Watt	60B 8-565
R13	47 Ohms, 1 Watt	60B 14-470
R14	2,700 Ohms, 1 Watt	60B 14-272
R15	2,400 Ohms, 2.5 Watt Center-tapped Candohm	61A 5-3
R16	1,500 Ohms, 1/2 Watt	60B 8-152
R17	820 Ohms, 1/2 Watt	60B 8-821
R18	220 Ohms, 1/2 Watt	60B 8-221
R19	150 Ohms, 1/2 Watt	60B 8-151

CONDENSERS

C1	250 mmfd., Ceramic	65B 6-5
C2a	Gang, 420.0 mmfd. (max.) Ant. Section	68B 10
C2b	Gang, 193.8 mmfd. (max.) RF Section	
C2c	Gang, 90.0 mmfd. (max.) Osc. Section	65B 6-9
C3	105 mmfd., Ceramic	
C4	250 mmfd., Ceramic	65B 6-5
C5	105 mmfd., Ceramic	65B 6-9
C6	.05 mfd., 200 Volts, Paper	64B 1-32
C7	.001 mfd. min., Ceramic	65B 6-41
C8	.005 mfd., 600 Volts, Paper	64B 1-12
C9	.05 mfd., 200 Volts, Paper	64B 1-32
C10	105 mmfd., Ceramic	65B 6-9
C11	.005 mfd., 600 Volts, Paper	64B 1-12
C12	.001 mfd. min., Ceramic	65B 6-41
C13	250 mmfd., Ceramic	65B 6-5
C14a	30 mfd., 150 Volts	Elect. 67C 7-52
C14b	40 mfd., 150 Volts	
C14c	20 mfd., 150 Volts	

C15	.18 mfd., 200 Volts, Paper	64A 2-2
Note: In sets with model numbers ending in "UL", C15 is .1 mfd., 400 V.		
C16	.05 mfd., 400 Volts, Paper	64B 1-22
C17	100 mfd., 25 Volts, Elect.	67A 4-6
C18	.25 mfd., 200 Volts, Paper	64B 1-28
C19	15 mmfd., 500 Volts, Ceramic	65B 6-18

COILS, TRANSFORMERS, ETC.

L1	Antenna, Loop	(Part of Cabinet)
L2	Coil, RF	69B 58
L3	Coil, Oscillator	69A 57
L4	Coil, Antenna Loading	69A 45-1
T1	Transformer, 1st IF	72B 55
T2	Transformer, 2nd IF	72B 56
T3	Transformer, Output	98A 21
M1	Speaker (4"x6" PM) and Output Transformer	78B 38-1
M2	Rectifier, Selenium	93A 1-4
SW1	Switch, Power Change DPDT, for "N" models	77A 19-2
	4PDT, for "UL" models	77A 19-1
SW2	Switch, On-Off (DPST)	(Part of R8)

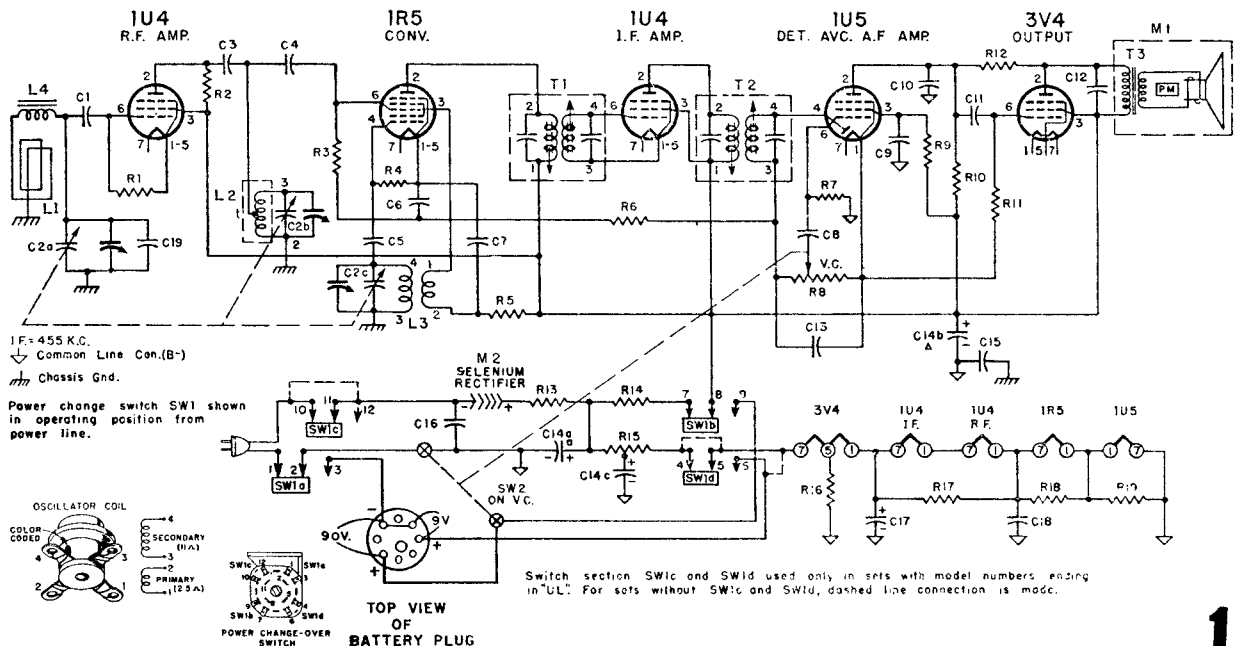

MANUAL OF 1950 MOST-OFTEN-NEEDED RADIO DIAGRAMS

Admiral

CHASSIS 9E1
MODELS 9E15, 9E16, 9E17

FM ALIGNMENT EQUIPMENT

Any standard brand vacuum tube volt-meter with a DC scale of not over 5 volts is suitable. A 3-volt zero center scale is desirable. A signal generator with a frequency range up to 110 MC. is desirable. It is possible however, to align the receiver with a signal generator going to 20 or 30 megacycles, by using the harmonics

Data on alignment of these models is continued on page 13, the schematic is on page 14, and the parts list and other facts are on page 15.

AM ALIGNMENT PROCEDURE

- Use regular output meter connected across speaker voice coil.
- Turn receiver Volume Control full on; Tone Control full treble.
- AM loop antenna must be connected and placed in the same relative position to the chassis as when in cabinet.
- Use lowest output setting of signal generator that gives a satisfactory reading on meter.

Step	Connect Signal Generator	Dummy Antenna Between Radio and Signal Generator	Signal Generator Frequency	Receiver Dial Setting	Adj. Trimmers in Following Order to Max.
Set Band Switch to Broadcast Position (center) and be sure to follow instructions under heading "Important Preliminary Alignment Steps." Loop antenna must be connected.					
1	Gang condenser antenna stator	.1 MFD	455 KC	Tuning gang wide open	A-B (2nd IF) C-D (1st IF)
2	Lug on AM Antenna Stator	.1 MFD	1620 KC	Tuning gang wide open	E (oscillator)
3	Place generator lead close to loop of set to obtain adequate signal. No actual connection (signal by radiation).		1400 KC	Tune in signal	F (antenna)

AM antenna trimmer adjustment "F" in step 3 should be repeated after set and antenna have been installed in cabinet. Important: AM antenna trimmer may not peak properly if antenna leads are not routed properly or separated as originally made.

SETTING SIGNAL GENERATOR TO CENTER OF I.F. SELECTIVITY CURVE

CAUTION: Due to the difficulty of setting a signal generator to the accuracy required by this operation, extreme care must be exercised in making each setting. Otherwise, improper alignment of the ratio detector and consequent audio distortion will result.

EXAMPLE: (See Figures 4 and 5)

Voltage reading in Step 4a is + 1.5 volts.

Generator frequency on low side of 10.7 MC for a reading of + 1 volt DC = 10.640 MC.

Generator frequency on high side of 10.7 MC for a reading of + 1 volt DC = 10.800 MC.

Center frequency is obtained by adding 10.640 and 10.800, then dividing by 2. For these readings it will be 10.72 MC.

Set generator frequency to 10.72 MC as this is center of selectivity curve as shown in Figure 5.

Note: Numerical vernier dial readings may be used instead of MC.

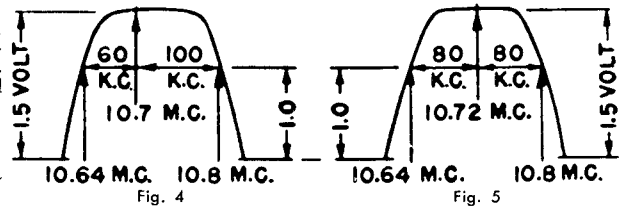

TYPICAL SELECTIVITY CURVES

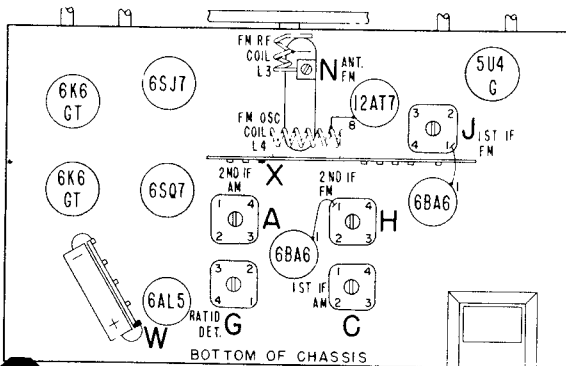
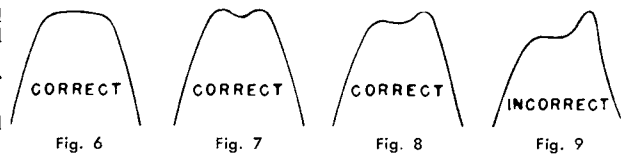

Fig. 10 Bottom Trimmer Location

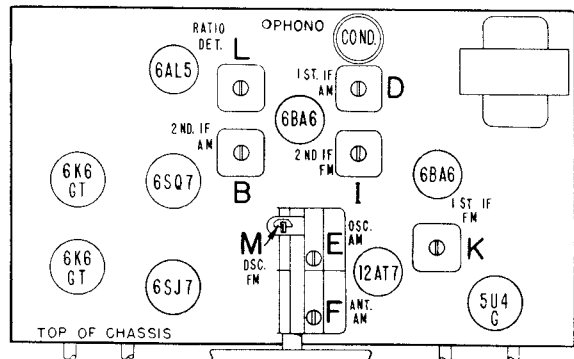

Fig. 11. Top Trimmer Location

MANUAL OF 1950 MOST-OFTEN-NEEDED RADIO DIAGRAMS

Admiral

CHASSIS 9E1
MODELS 9E15, 9E16, 9E17

FM I.F. AND RATIO DETECTOR ALIGNMENT

- Keep output indicator leads well separated from signal generator leads and chassis wiring.
- Band switch in FM position (fully to the right).
- While peaking IF's, keep reducing signal generator output so VTVM reading is approximately +1.5 volts DC with exception of Step #5.
- To avoid splitting the slotted head of iron core tuning slugs in the IF transformers, use an insulated alignment tool with a 1/8" wide screwdriver blade. Do not exert undue pressure as threads of slugs may strip.
- Speaker must be connected during alignment.
- FM antenna disconnected during alignment.

	Connect Signal Generator	Generator Frequency	Receiver Dial Setting	Output Indicator and Special Connections	(Adjust as Follows very carefully)
1	Thru .001 cond. to pin #1 of 6BA6 2nd IF. (Ground to chassis, close to tube.)	10.7 MC unmodulated.	Tuning gang wide open	Connect VTVM (DC probe) from point "W" to chassis. (See Fig. 10)	"G" (ratio detector primary) for maximum reading on VTVM
2	**Thru .001 cond. to pin #1 of 6BA6 1st IF. (Ground to chassis, close to tube).	"	"	" "	"H" and "I" (2nd IF trans.) for maximum reading on VTVM.
3	Across ends of FM antenna twin lead	"	"	" "	"J" and "K" (1st IF trans.) for maximum on VTVM. Readjust G, H, I, J, K, for maximum. (Keep reducing generator output to keep VTVM at 1.5 volts)
4	"	a. Reduce output of signal generator until VTVM reads EXACTLY +1.5 volts DC. b. Tune generator frequency above 10.7 MC until VTVM reads EXACTLY +1.0 volt. Note EXACT generator frequency. Extreme care in reading this is essential. c. Tune generator frequency below 10.7 MC until VTVM reads EXACTLY +1.0 volt. Note EXACT generator frequency. Extreme care in reading this is essential. d. Add generator frequency in step c to generator frequency in step b and divide by 2. The result is the center frequency of the IF curve to be used in step 5. See example under heading "Setting Signal Generator to Center of I.F. Selectivity Curve". e. Tune generator frequency above and below 10.7 MC and note voltage reading on VTVM at different frequency points until you have a good impression of the shape of the selectivity curve. If you have two peaks as in Figures 7 or 8, note readings (voltage) of both peaks. If one peak is over 20% higher than the other one, it will be necessary to realign IF's. A selectivity curve that would require realignment is illustrated by Figure 9.			
5	"	Center of IF selectivity curve per step 4d above.	Tuning gang wide open	Connect VTVM (DC probe) from point "X" to chassis. (See Fig. 10.)	"L" (ratio detector secondary) for zero voltage reading on VTVM. (The correct zero point is located between a positive and a negative maximum.)

If any adjustments were very far off, it is desirable to repeat steps 3, 4 and 5.

**Do not feed I.F. signal into converter grid as this will cause mis-alignment.

FM RF ALIGNMENT PROCEDURE

Step	Connect Generator	Generator Frequency	Receiver Gang or Dial Setting	Output Connections	Adjust as follows (very carefully)
1		†109 MC (unmodulated)	Gang fully open	Connect VTVM (DC probe) from point "W" to chassis.	*M (oscillator) and N (antenna) for maximum
2	To ends of FM antenna twin lead thru 120 ohm carbon resistors in series with each generator lead.	87 MC (unmodulated)	Tune in Signal. (Gang should be closed or almost closed.)	"	If signals in steps 1 and 2 will not tune in at gang tuning extreme (± 0.5 MC), it will be necessary to spread or squeeze oscillator coil turns and then repeat steps 1 and 2 until correct results are obtained.
3		106 MC (unmodulated)	Tune in Signal	"	Readjust N for maximum VTVM reading, while rocking gang. If trimmer does not peak, it will be necessary to squeeze or spread turns of FM antenna coil. Check calibration and tracking at 90 MC. Calibration error should not exceed ± 0.5 MC. If necessary, repeat steps 1, 2, 3 until correct results are obtained.

* It is advisable to adjust generator output so VTVM readings do not exceed approximately +1.5 V. DC while peaking.
 † If your signal generator does not reach this frequency, use harmonics

MANUAL OF 1950 MOST-OFTEN-NEEDED RADIO DIAGRAMS

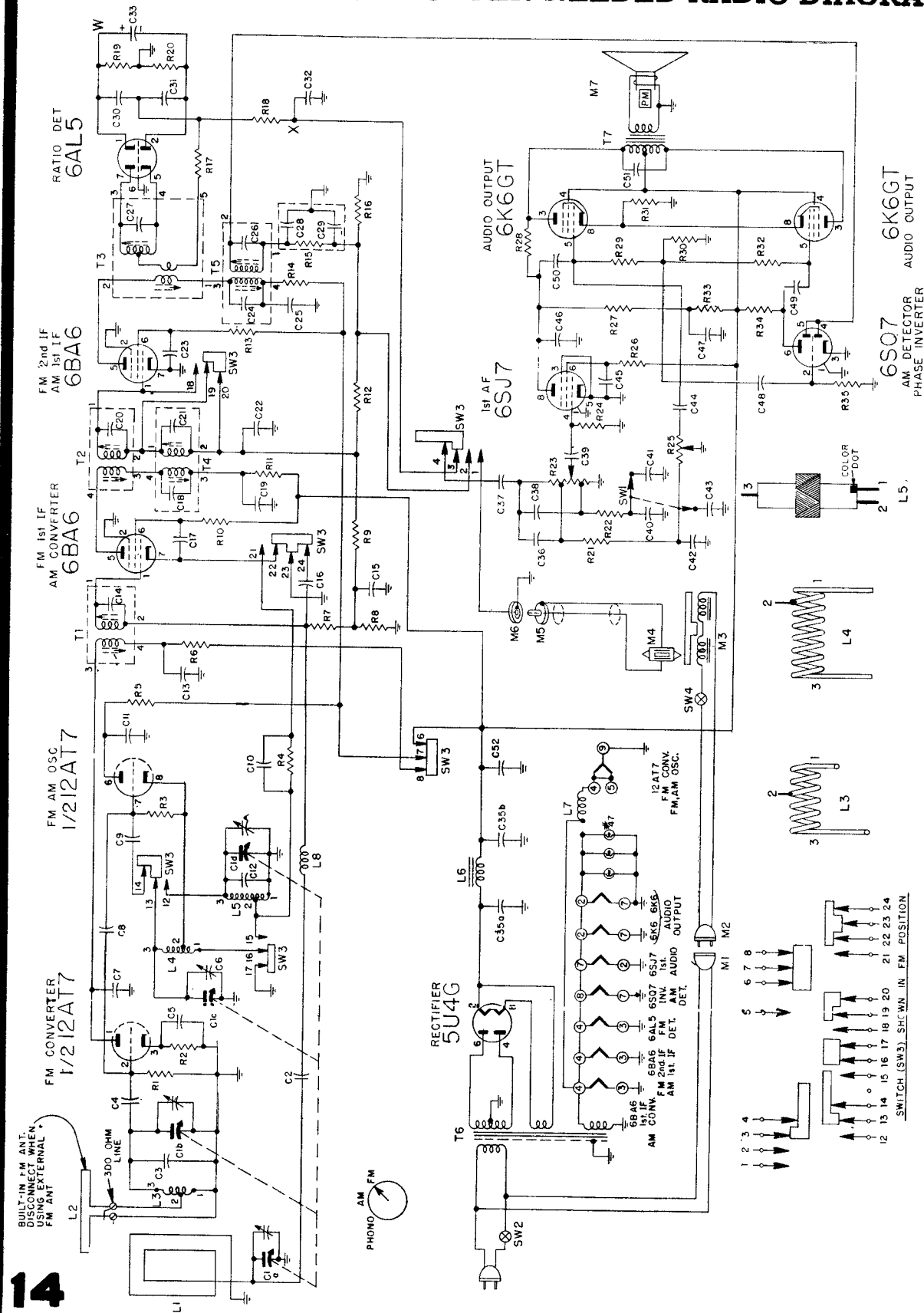

Admiral

MANUAL OF 1950 MOST-OFTEN-NEEDED RADIO DIAGRAMS

Admiral

CHASSIS 9E1
MODELS 9E15, 9E16, 9E17

RESISTORS

Symbol	Description	Part No.
R1	1 Megohm, 1/2 Watt	60B 8-105
R2	470 ohms, 1/2 Watt	60B 8-471
R3	22,000 ohms, 1/2 Watt	60B 8-223
R4	470 ohms, 1/2 Watt	60B 8-471
R5	4,700 ohms, 1/2 Watt	60B 8-472
R6	27,000 ohms, 1 Watt	60B 14-273
R7	1.5 Megohms, 1/2 Watt	60B 8-155
R8	1.5 Megohms, 1/2 Watt	60B 8-155
R9	1 Megohm, 1/2 Watt	60B 8-105
R10	27,000 ohms, 1 Watt	60B 14-273
R11	4,700 ohms, 1/2 Watt	60B 8-472
R12	1 Megohm, 1/2 Watt	60B 8-105
R13	27,000 ohms, 1 Watt	60B 14-273
R14	4,700 ohms, 1/2 Watt	60B 8-472
*R15	47,000 ohms, 1/4 Watt	60B 8-224
R16	220,000 ohms, 1/2 Watt	60B 8-224
R17	390 ohms, 1/2 Watt	60B 8-391
R18	27,000 ohms, 1/2 Watt	60B 8-273
R19	6,800 ohms, 1/2 Watt, 5%	60B 7-682
R20	6,800 ohms, 1/2 Watt, 5%	60B 7-682
R21	47,000 ohms, 1/2 Watt	60B 8-473
R22	10,000 ohms, 1/2 Watt	60B 8-103
R23	1 Megohm Volume Control	75B 3-6
R24	4.7 Megohms, 1/2 Watt	60B 8-475
R25	2 Megohms Tone Control	75B 1-33
R26	1.5 Megohms, 1/2 Watt	60B 8-155
R27	330,000 ohms, 1/2 Watt	60B 8-334
R28	1.5 Megohms, 1/2 Watt	60B 8-155
R29	270,000 ohms, 1/2 Watt	60B 8-274
R30	270,000 ohms, 1/2 Watt	60B 8-274
R31	270 ohms, 2 Watt	60B 20-271
R32	270,000 ohms, 1/2 Watt	60B 8-274
R33	47,000 ohms, 1/2 Watt	60B 8-473
R34	470,000 ohms, 1/2 Watt	60B 8-474
R35	4.7 Megohms, 1/2 Watt	60B 8-475

CONDENSERS

Symbol	Description	Part No.
C1a	486 mmfd. (max) AM RF	Gang 68 B25
C1b	15 mmfd. (max) FM RF	
C1c	15 mmfd. (max) FM Osc.	
C1d	143 mmfd. (max) AM Osc.	
C2	35 mmfd., Zero Temp. Coeff., Ceramic	65B 6-57
C3	7 mmfd., ± 1 mmfd., —.00047 Temp. Coeff., Ceramic	65B 6-45
C4	.002 mfd., "Hi-K" Ceramic	65B 9-38
C5	.001 mfd. min., Ceramic	65B 6-41
C6	3 to 12 mmfd., Trimmer (Silver Ceramic)	66A 19-2
C7	40 mmfd., 2%, Zero Temp. Coeff., Ceramic	65B 6-22
C8	2 mmfd., ± 5 mmfd., Zero Temp. Coeff., Ceramic	65B 6-58
C9	50 mmfd., Ceramic	65B 6-4
C10	.005 mmfd., "Hi-K" Ceramic	65B 9-51
C11	.005 mfd. min., Ceramic	65A 10-1
C12	10 mmfd., Zero Temp. Coeff.	65B 6-44
C13	.01 mfd. min., Ceramic	65A 10-3
C14	100 mmfd., 3%, Silver Mica	Part of T1
C15	.01 mfd. min., Ceramic	65A 10-3
C16	.01 mfd. min., Ceramic	65A 10-3
C17	.01 mfd. min., Ceramic	65A 10-3
C18	200 mmfd., 3%, Silver Mica	Part of T4
C19	.01 mfd. min., Ceramic	65A 10-3
C20	100 mmfd., 3%, Silver Mica	Part of T2
C21	200 mmfd., 3%, Silver Mica	Part of T4
C22	.01 mfd. min., Ceramic	65A 10-3
C23	.01 mfd. min., Ceramic	65A 10-3
C24	200 mmfd., 3%, Silver Mica	Part of T5
C25	.01 mfd. min., Ceramic	65A 10-3
C26	200 mmfd., 3%, Silver Mica	Part of T5

Symbol	Description	Part No.
C27	90 mmfd., 3%, Silver Mica	Part of T3
*C28	100 mmfd., Ceramic	
*C29	100 mmfd., Ceramic	
C30	100 mmfd., 5%, —.00075 Temp. Coeff., Ceramic	65B 6-7
C31	100 mmfd., 5%, —.00075 Temp. Coeff., Ceramic	65B 6-7
C32	.002 mfd., 600 Volts, Paper	64B 1-14
C33	4 mfd., 150 Volts, Electrolytic	67A 4-2
C35a	30 mfd., 350 Volts	Electrolytic. 67C 6-22
C35b	30 mfd., 350 Volts	
C36	200 mmfd., "Hi-K" Ceramic	65B 9-14
C37	.005 mfd. min., Ceramic	65A 10-1
C38	100 mmfd., Ceramic	65B 6-3
C39	.005 mfd. min., Ceramic	65A 10-1
C40	.01 mfd. min., Ceramic	65A 10-3
C41	.02 mfd., 400 Volts, Paper	64B 1-24
C42	.005 mfd. min., Ceramic	65A 10-1
C43	.005 mfd. min., Ceramic	65A 10-1
C44	.005 mfd. min., Ceramic	65A 10-1
C45	.1 mfd., 400 Volts, Paper	64B 1-20
C46	100 mmfd., Ceramic	65B 6-3
C47	.1 mfd., 400 Volts, Paper	64B 1-20
C48	.01 mfd. min., Ceramic	65A 10-3
C49	.01 mfd. min., Ceramic	65A 10-3
C50	.01 mfd. min., Ceramic	65A 10-3
C51	.002 mfd., 600 Volts, Paper	64B 1-14
C52	.01 mfd. min., Ceramic	65A 10-3

* Part of enclosed Diode Filter Unit 63A-1. This unit consists of R15, C28, C29 (see schematic). If a section of the unit becomes defective, replace with exact duplicate or individual components of proper value.

POINTER SETTING

With the gang open, the pointer should be at the position as shown in the stringing diagram, that is, the end of the pointer should line up with the "AM" lettering on the dial scale. If the pointer is in a different position, move it by hand while keeping the gang open.

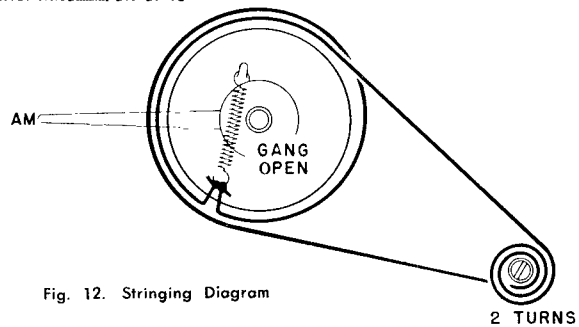

Fig. 12. Stringing Diagram

2 TURNS

VOLTAGE CHART

Line Voltage 117.

Voltage readings taken with a vacuum tube voltmeter. Socket terminals marked with an asterisk * indicate much lower voltage or zero voltage if measured with a 1000 ohm-per-volt meter.

Voltages read between socket terminals and ground, unless otherwise indicated.

Band switch in FM position.

Dial turned to low frequency end.

Volume Control—minimum.

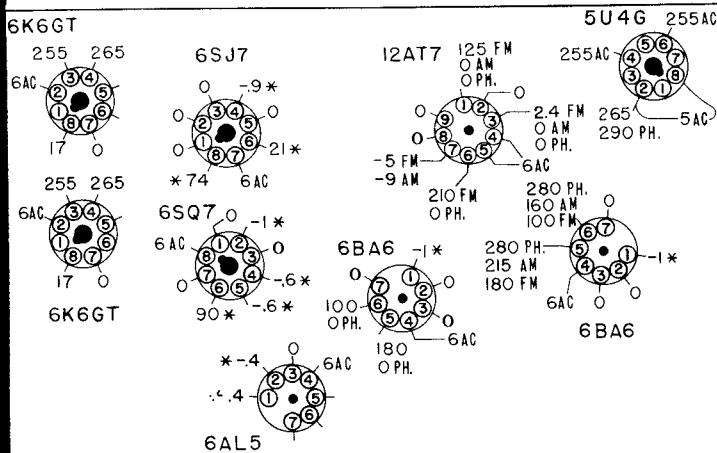

*If taken with a 1000 ohm-per-volt meter, readings will be lower or zero.

MANUAL OF 1950 MOST-OFTEN-NEEDED RADIO DIAGRAMS

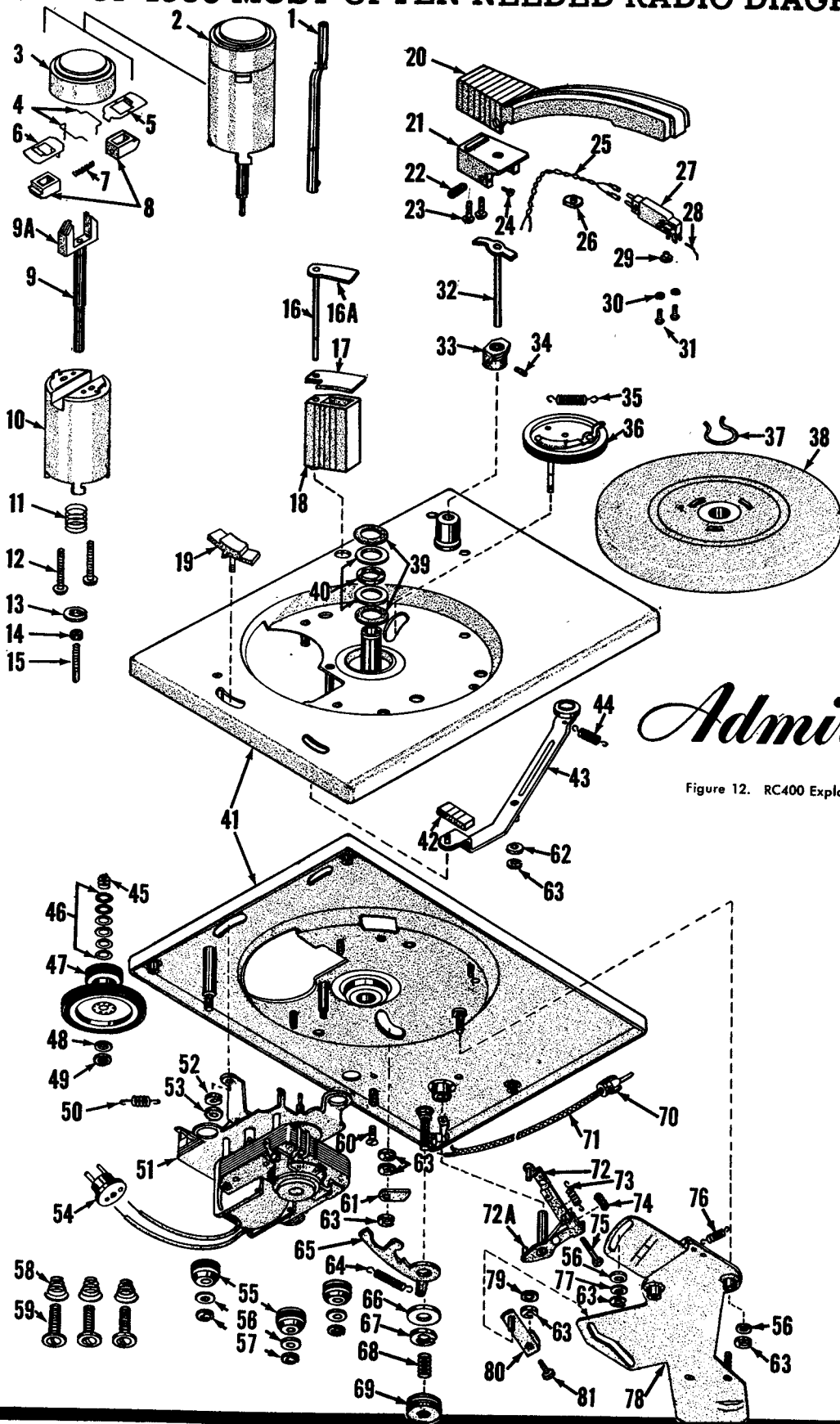

Admiral

Figure 12. RC400 Exploded View.

MANUAL OF 1950 MOST-OFTEN-NEEDED RADIO DIAGRAMS

Admiral

RC400 RECORD CHANGER

The exploded view of this changer is shown on page 16, and the parts are listed and described below. Adjustment and repair instructions are given below and continued to page 23.

OPERATING INSTRUCTIONS

SELECTING CENTERPOST

To play 45 RPM records, insert the large diameter (plastic) centerpost (2) into the center of the turntable (38). While holding the turntable with one hand, turn the centerpost counter-clockwise until the lock-in-lugs fall into and lock in the three slots in the turntable. To remove this centerpost, hold the turntable with one hand and turn the centerpost clockwise; then lift it up.

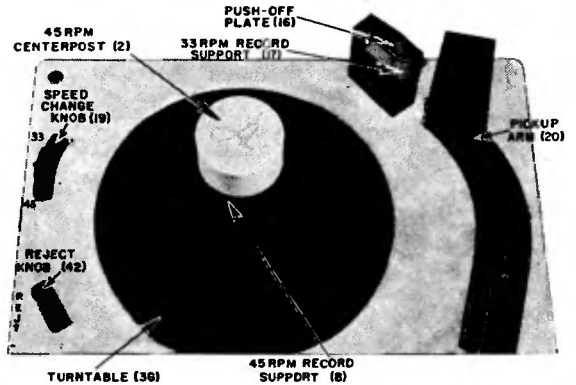

Figure 1. RC400 Record Changer (Top View).

To play 33 RPM records, insert the small diameter (metal) centerpost (1) into the center of the turntable and press it down until it "locks" in place. To remove this centerpost, merely lift it straight up and out.

SETTING SPEED CHANGE KNOB

To play 45 RPM records, set the Speed Change Knob (19) so that its indicating arrow points to "45".

RC400 PARTS LIST

Ref. No.	Part Number	Description	Ref. No.	Part Number	Description
1	G400B 409	33 RPM Centerpost	42	403A 302	Reject Knob
2	G400B 410	†45 RPM Centerpost Complete	43	G400A 414	Reject Lever and Studs
3	403A 1	45 RPM Centerpost Cop	44	405A 127	Reject Lever Return Spring
4	414A 35	Slicer Return Spring	45	98A 54-5	Idle Wheel Retaining Spring
5	401A 276	Top Slicer		98A 54-6	Fibre Washer, 3/16" ID x 9/32" OD (4 req.)
6	401A 275	Bottom Slicer	46	98A 54-11	Metal Washer, 3/16" ID x 9/32" OD (Quantity varies; replace as found in changer.)
7	405A 125	Record Supports Return Spring	47	98A 54-7	Compound Idle Wheel
8	403A 40	Record Supports	48	98A 54-8	Fibre Washer (5/32 ID x 3/8" OD)
9	G400A 411	Slicer Cam and Shaft	49	98A 54-9	Metal Washer (5/32" ID x 5/16" OD)
10	403B 43	45 RPM Centerpost Base	50	98A 54-10	Idle Wheel Spring
11	405A 124	45 RPM Push-Off Return Spring	51	407C 300	Motor; 33 and 45 RPM; 60 cycle
12	60-1000-C2-47	Screw, # 6-32x1" R.H.M.S. (2 req.)	52	3A 4-5-47	#6 Split Lock Washer
13	401A 229	Retaining Ring	53	2A 1-11-47	Hex. Nut, # 6-32
14	402A 312	Lock Nut	54	88A 8-1	Motor Plug (male)
15	402A 313	45 RPM Push-Off Adjusting Shaft	55	406A 301	Motor Mounting Grommet (3 req.)
16	G400A 417	33 RPM Push-Off Plate and Shaft	56	4B 1-68-47	Flat Washer, .196x3/8x1/32 (5 req.)
17	401A 311	33 RPM Record Support	57	401A 317	Retaining Ring (3 req.)
18	G400A 418	Record Support Housing and Sleeve	58	405A 308	Changer Mtg. Spring (3 req.)
19	403A 42	Speed Change Knob	59	402A 334	Changer Mtg. Screw (3 req.)
20	403B 300	Pickup Arm	60	402A 115	Plasticscrew, #6x3/8
21	G400A 433	Pickup Arm Counterweight	61	401A 307	Trip Bracket
22	402A 320	Pickup Arm Pivot Screw	62	401A 173	Flat Washer
23	1A73-10	Screw, #6x3/8 Shakeproof Type (2 req.)	63	401A 177	Retaining Ring (7 req.)
24	42-187-C2-47	Lock Screw, # 4-40x3/16 F.H.M.S	64	405A 302	Set-Down Spring
25	G400A 439	Cable and Pin Jock Assembly	65	401A 315	Index Bracket
26	2810-5-59	Speed Nut	66	4B 1-87-47	Flat Washer, .25x3/8x1/32
27	409A 300	Cartridge with needle (See Figure 10)	67	401A 229	Retaining Ring
	or		68	405A 307	Lift Adjusting Lock Spring
	409A 301	Cartridge with needle (See Figure 11)	69	402A 306	Pick Up Arm Lift Adjusting Nut
28	98A 15-6	Needle (See Figure 10)	70	88A 2-3	Plug, Male (for shielded cable)
	or		71	413A 11-1	Shielded Cable and Plug
	98A 15-14	Needle (See Figure 11)	72	G400A 427	Pickup Arm Lever and Trip Bracket (less springs)
29	98A 54-2	Needle Nut (Knurled)	73	405A 127	Trip Tension Spring
30	4B 1-7-47	Flat Washer, .096x3/16x1/32 (2 req.)	74	405A 305	Trip Adjusting Lock Spring
31	402A 335	Screw, #2x1/4 Fil. Hd. (2 req.)	75	402A 328	Trip Adjusting Screw
32	G400A 401	Pickup Arm Lift Rod and Plate	76	405A 92	Cycle Spring
33	G400A 432	Pivot Bracket and Collar (includes Allen screw)	77	4B 1-178-0	Flat Washer, .196x3/8x1/64
34	1A 43-9	Allen Hd. Set Screw, # 6-32x1/4	78	G400B 416	Drive Bracket (includes hub and studs)
35	405A 303	Drive Wheel Spring	79	4B 1-67-47	Flat Washer, .196x5/16x1/32
36	G400A 407	Drive Wheel Assembly (less spring)	80	G400A 420	Push-Off Bracket Assembly
37	414A 300	Turntable Retaining Clip	81	65-375-C2-47	Push-Off Adjustment Lock
38	G400A 403	Turntable and Hub Assembly		41A 17-40	Operating Instructions for Models 5W11, 5W12
39	412A 300	Cork Washer (2 req.)		S275	Service Manual for RC400 Record Changer
40	415A 300	Thrust Bearing Assembly		1A45-2	Allen Wrench, #6
41	G400C 438	Changer Pan and Stud Assembly			

†This 45 RPM centerpost (G400B410) is very similar to, but is not interchangeable with, the 45 RPM centerpost (G400B329) used in models RC221, RC222. The centerposts can be readily identified by noting

that the length of the un-threaded portion of the push-off adjusting shaft (15) is approximately 5/16" in G400B410, and 3/4" in G400B329.

MANUAL OF 1950 MOST-OFTEN-NEEDED RADIO DIAGRAMS

Admiral RC400 Changer, continued

To play 33 RPM records, set this knob so its indicating arrow points to "33". When moving this knob to either position, make sure that the knob "clicks" into position.

This control also has a center ("neutral") position for disengaging the rubber-tired idler wheel (47). The changer pan is not marked "neutral" but the position can be felt when the Speed Change Knob is halfway between "33" and "45". In this position, the compound idler wheel is not in contact with the drive shaft or the turntable. **When the record changer is not going to be used for some time, set the speed change knob in the center position.**

LOADING AND STARTING THE RECORD CHANGER

To load 45 RPM records, place as many as ten over the 45 RPM centerpost so that the bottom record rests on the record supports (8). To load 33 RPM records, place as many as ten over the 33 RPM centerpost so that the bottom record rests on the ledge on the centerpost (1) and the 33 RPM record support (17). Start the changer by turning the Radio-Phono switch on the radio to the "Phono-On" position.

STOPPING AND UNLOADING

Turn changer off by turning Radio-Phono switch on the radio to "Phono-Off" position. Do not turn changer off during change cycle. To unload, merely lift records straight up.

THE CHANGE CYCLE

45 RPM OPERATION (See Figures 2, 3 and 4)

If at all possible, we recommend that you carefully observe the operation of a changer that is in normal operating condition. It is a good idea to rotate the turntable by hand and repeat the change cycle until you understand the function of each part.

The changer operates as follows: The turntable (38) is driven by the smaller of the two rubber tires on the compound idler wheel (47), riding against the outer rim of the turntable.

The speed of the turntable is determined by the setting of the speed change knob (19). When the knob is in the "45" position, the larger rubber tire on the compound idler wheel (47) rides against the 45 RPM section (larger diameter) of the motor drive shaft. When the knob is moved to "33", the compound idler

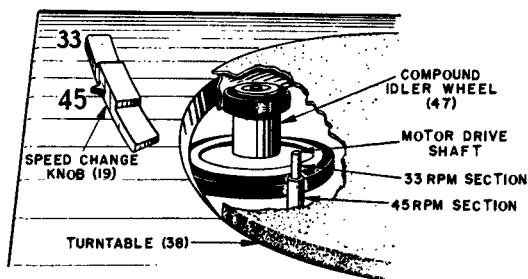

Figure 2. Compound Idler Wheel and Motor Drive Shaft.

wheel moves so that the larger tire rides against the 33 RPM section (smaller diameter) of the motor drive shaft. See Figure 2.

The changer mechanism is driven through change cycle by the knurled hub of the turntable rotating the rubber tired drive wheel (36). During normal playing, the drive wheel does not touch the knurled hub of the turntable. See Figure 3A. As the needle enters the record spiral grooves and moves towards the centerpost, the pickup arm lever and stud (72) moves simultaneously and rotates the trip bracket (61) counter-clockwise. Since the trip bracket and drive wheel are on the same shaft, the drive wheel is pivoted approximately 10 degrees counter-clockwise. The rubber tire contacts the knurled hub of the turntable, and is rotated in a counter-clockwise direction. See Figure 3B.

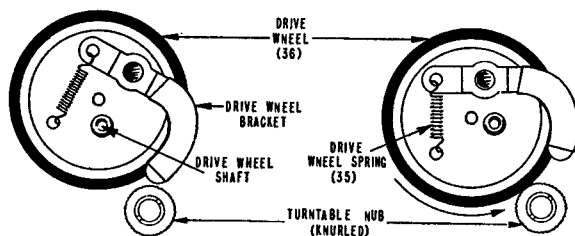

Figure 3A

Figure 3B

Drive Wheel Positions.

The drive wheel shaft is fitted through the drive bracket (78) and is mounted OFF CENTER on the drive wheel (36). Due to the cam action of the "off-center" drive wheel (36), rotation of the drive wheel, by the knurled hub of the turntable, forces the drive shaft out. Since the drive shaft is fitted through the drive bracket (78), the drive bracket is pivoted around the drive bracket hub. The cycle spring (76) maintains pressure on the drive bracket so that the drive wheel tire is kept in contact with the knurled hub. After the changer has been tripped and the drive bracket begins to be pivoted by the movement of the drive wheel, the arm lift incline (78A) on the drive bracket moves across the lift rod moving it upward. This lifts the pickup arm off of the record. Stud (78C) on the drive bracket now contacts the pickup arm lever and begins to move it so the pickup arm moves out from the center of the record.

At about this time, the push-off adjusting shaft (15) on the 45 RPM centerpost (2) starts moving up the push-off incline (78B) on the drive bracket (78). See figure 12. This causes the push-off shaft to move up into the centerpost. As the push-off shaft moves into the centerpost. As the push-off shaft moves into the centerpost, the slicers (5 and 6) ride on the incline of the slicer cam and consequently move out of the centerpost. The record supports (8) are also brought into the centerpost as each slicer is hooked to the record support on the opposite side of the centerpost.

As the drive bracket continues to pivot, the pickup arm continues to move away from the record, the slicers (5 and 6) continue to come out, and the record supports continue to pull in. When the pickup arm has moved to the right almost as far as it will go, the record supports (8) have pulled into the centerpost enough to drop the bottom record to the turntable and the slicers are out far enough to hold up the remainder of the stack of records.

MANUAL OF 1950 MOST-OFTEN-NEEDED RADIO DIAGRAMS

Admiral RC400 Changer, continued

The pickup arm lever control stud (72A) riding against the indexing edge of the index bracket (65) controls the movement of the pickup arm. The index bracket (65) and set down spring (64) prevent the pickup arm from moving out too far. (Later in the change cycle the index bracket (65) and set-down spring (64) control the set-down point.)

At this point, the drive wheel (36) has gone through one-half of its rotation and as the drive wheel continues to rotate, the drive bracket (78) will begin to return to its normal (out of change cycle) position.

The set-down spring (64) keeps the pickup arm lever (72) in contact with the arm control stud (78C) on the drive bracket. Therefore as the drive bracket moves back toward its normal position, the pickup arm is moved in toward the set-down point. When the pickup arm lever stud (72A) has reached the indexing point (notch) in the index bracket, the pickup arm has reached the set-down point and stops moving in toward the centerpost. At this time, the drive bracket has pivoted to a point where the lift rod (32) starts moving down the arm lift incline (78A) in the drive bracket and the pickup arm starts moving down toward the record. When the arm has moved down about half-way, the second stud on the drive bracket (78D) moves the index bracket (65) away from the stud on the pickup arm lever so that the pickup arm is free to travel in on the lead in grooves on the record.

Almost simultaneously, the push-off adjusting shaft (15) is riding down the push-off incline (78B) on the drive bracket. This allows the push-off return spring (11) on the centerpost to pull the cam and shaft assembly (9) down.

The record supports are forced out of the centerpost by their return spring (7) and the slicers are moved into the centerpost by the slicer return springs (4). When the slicers are all the way in, the stack drops to the record supports (8).

The drive wheel is no longer in contact with the knurled hub but it is rotated approximately 20 degrees further by the drive wheel bracket, which is held against the knurled hub of the turntable by the drive wheel bracket spring (35).

When the drive wheel bracket has rotated past the knurled hub, the drive wheel must be rotated another 10 degrees by the trip bracket (61), or reject lever (43), before it will contact the knurled hub and begin the change cycle. When the reject knob (42) is moved to the "Rej" position, the reject lever roller rotates the drive wheel the necessary 10 degrees and the change cycle begins.

33 RPM OPERATION

The change cycle for 33 RPM operation is exactly the same as for 45 RPM operation, except for change cycle time and the fact that 33 RPM records are supported by the offset on the 33 RPM centerpost and the 33 RPM record support (17), and are pushed off by the push-off plate (16).

When the drive bracket (78) has pivoted to the point where the pickup arm is clear of the record, the stud (80A) on the push-off bracket (80) is moved by the slot (78E) in the drive bracket. This movement causes the push-off plate (16) to pivot and push-off the bottom record. The remainder of the records are held back by the small sliding piece at the top of the centerpost. When the drive bracket pivots back to its normal playing position, the push-off bracket stud (80A) follows the slot in the drive bracket and causes the push-off plate to pivot back to its normal position. Then the record stack drops to the record support (17) from the push-off plate (16).

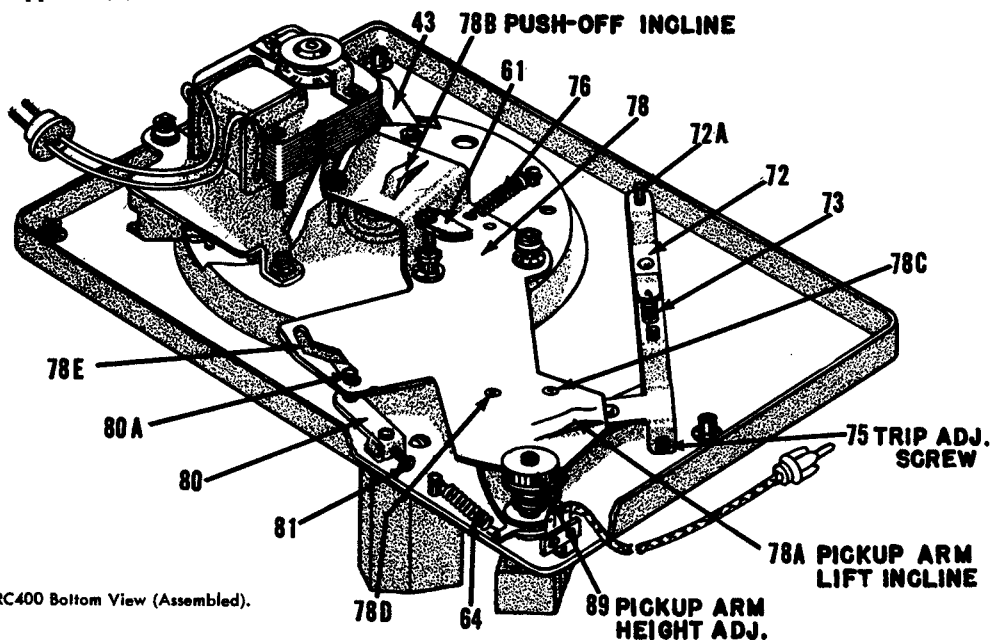

Figure 4. RC400 Bottom View (Assembled).

MANUAL OF 1950 MOST-OFTEN-NEEDED RADIO DIAGRAMS

Admiral RC400 Changer, continued

ADJUSTMENTS

TRIP ADJUSTMENT

This record changer employs the position type trip; that is, it trips into change cycle when the needle in the pickup arm reaches a given distance from the center of the record. If the trip is properly adjusted, the record changer will trip into change cycle when the needle is between 2" to 2-3/16" from the center of the hole in the turntable or approximately half way in on the spiral groove in the center of the record.

If the record changer does not trip at the proper position, it will be necessary to adjust the trip adjusting screw (75). See figure 4. Turning this screw in (clockwise) moves the trip point away from the centerpost. Turning it out, moves the trip point nearer to the centerpost.

If the screw is turned all the way out, the changer may not trip. If it is turned in too far, the changer may trip before the record finishes playing.

33 RPM PUSH-OFF ADJUSTMENT

(See Figures 1 and 4)

If 33 RPM records do not drop to the turntable during change cycle, it may be necessary to correct the push-off adjustment.

The push-off is properly adjusted when the leading edge of the push-off plate (16) extends to a maximum of 1/32" beyond the edge of the record support (17) during change cycle.

To make this adjustment, proceed as follows:

1. With the record changer in change cycle, rotate the turntable by hand until the pickup arm STOPS moving away from the centerpost.
2. Loosen the set screw (81) on the push-off bracket (80) and move the push-off plate (16) so that its leading edge extends 1/32" beyond the edge of the record support (17). Then tighten the set screw (81).
3. Load the record changer with 33 RPM records, place the changer in operation and keep rejecting records until the stack has been dropped to the turntable.
4. If records still do not drop properly, repeat steps 1 through 3.

ADJUSTMENT OF SET-DOWN POINT

(See Figures 4 and 5)

This record changer does not have a conventional set-down screw adjustment. The pickup arm should set-down properly unless the Allen set screw (34) on the pivot collar (33) is loosened, or excessive pressure has been applied to the pickup arm.

When properly adjusted for correct set-down, the needle point will set-down between 2-9/16" and 2-10/16" from the near side of the 45 RPM centerpost. (Between 3-5/16" and 3-6/16" from center of the hole in the turntable.) Making this adjustment for 45 RPM records, automatically provides correct set-down for 33 RPM records.

If the pickup arm does not set-down properly, the set-down point adjustment should be made as follows:

1. Insert the 45 RPM centerpost (2); set the speed change knob (19) to the "45" position; move the reject knob (42) to the "Rej" position and then rotate the turntable (clockwise) by hand JUST to the point where the pickup arm stops moving in toward the centerpost and starts moving downward. DO NOT ROTATE THE TURNTABLE BEYOND THIS POINT.
2. Insert a #6 Allen wrench into the Allen set screw (34) on the pivot collar (33) as shown in Figure 5. Do NOT loosen the Allen set screw.

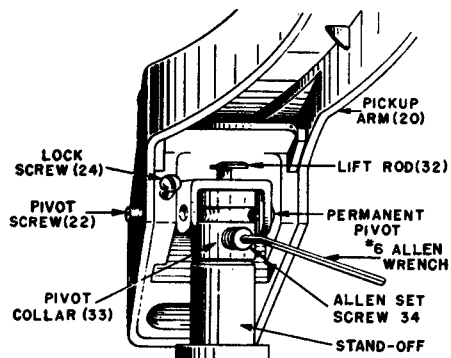

Figure 5. Pickup Arm Mounting Detail.

3. From the underside of the changer, hold the pickup arm lever and trip bracket assembly (72) STATIONARY so that it can not move down or to either side.
4. Slightly loosen the Allen set screw (34).
5. Place a ruler against the near side of the 45 RPM centerpost and then move the pickup arm until the distance between the needle and centerpost is from 2-9/16" to 2-10/16".
6. Tighten the Allen set screw (34) VERY CAREFULLY to avoid moving the pickup arm. Before firmly tightening the Allen set screw, make sure that there is a little space (ten thousandths of an inch) between the pivot collar (33) and the stand-off.

ADJUSTING THE PICKUP ARM HEIGHT

This record changer is designed so that when the needle rests 1/16" above the changer pan, the pickup arm will automatically lift high enough during change cycle to clear the top record of a stack of ten 33 RPM records on the turntable and will not lift high enough to strike the bottom record of a stack of 33 RPM records to be played.

MANUAL OF 1950 MOST-OFTEN-NEEDED RADIO DIAGRAMS

Admiral RC400 Changer, continued

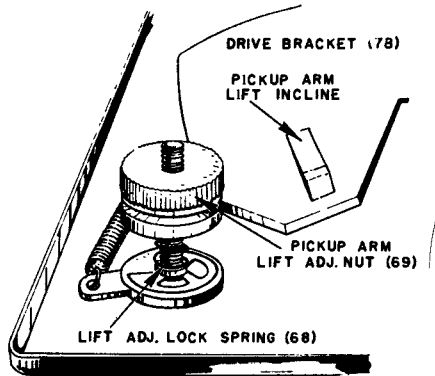

Figure 6. Adjusting Pickup Arm Height.

With the record changer out of change cycle and the pickup arm clear of the turntable, adjust the pickup arm lift adjusting nut (69) (see figure 6), so that the needle rests $1/16''$ above the top of the changer pan. Turning the nut (69) clockwise raises the pickup arm; turning it counter-clockwise lowers the pickup arm.

To check this adjustment, load the record changer with ten 33 RPM records. Turn the changer on and reject records until the stack has been dropped to the turntable. The pickup arm should not lift high enough to strike the bottom record (of the stack about to be played) but should lift high enough to play the tenth record on the turntable.

If, for some reason, the arm strikes the bottom record or will not lift high enough to play the tenth record, a compromise adjustment should be made. That is, raise the arm slightly to make the arm lift higher or lower the arm slightly to prevent it from striking the bottom record.

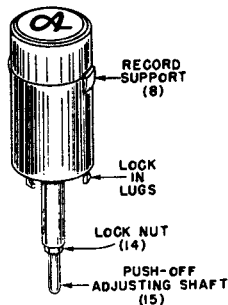

Figure 7. 45 RPM Centerpost.

45 RPM CENTERPOST ADJUSTMENT

If 45 RPM records do not drop to the turntable as they should, or if the turntable stalls during change cycle, it will be necessary to adjust the 45 RPM centerpost, (2).

The push-off adjusting shaft (15) is the only adjustment on this centerpost. When properly adjusted, the dimension from the bottom of the adjusting nut (14) to the end of the push-off adjusting shaft (15) is approximately $1/2$ inch. To make an adjustment, proceed as follows:

1. Turn the set off. Push the Reject knob (42) to the "Rej" position. Then rotate the turntable clockwise (to the right) by hand until the pickup arm moves as far away from the turntable as it will go. Do not continue to rotate the turntable beyond this point.
2. Insert the 45 RPM centerpost and lock it in place.
3. In this position the record supports (8) should be pulled into the centerpost until the top edge of the

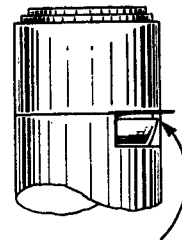

Corner of record support (8) must be slightly ($1/32''$) inside centerpost wall.

Figure 8. 45 RPM Centerpost Adjustment.

record supports are just inside the centerpost. You should only be able to see approximately $1/32$ of an inch of the centerpost wall. See figure 8.

4. If the record supports do not pull into the centerpost as far as the position shown in figure 8, remove centerpost, loosen the locknut (14) and turn the push-off adjusting shaft out (counter-clockwise) approximately one half turn.
5. Insert the centerpost and check to see if the record supports "pull in" to the proper position. If they do not, repeat step 4. If they pull in far enough, proceed with step 6.
6. Place a stack of 45 RPM records on the centerpost and turn the record changer on. Push the Reject knob to the "Rej" position and then keep rejecting records until the whole stack has been dropped to the turntable. If each record slides smoothly down the centerpost, the adjustment is satisfactory.

IMPORTANT: If the turntable stalls during change cycle, the push-off adjusting shaft may have been turned out too far. Remove the 45 RPM centerpost and run the changer through change cycle. If the changer does not stall with the centerpost removed, turn the push-off adjusting shaft in about four or five full turns and repeat steps 1 through 6 above.

MANUAL OF 1950 MOST-OFTEN-NEEDED RADIO DIAGRAMS

Admiral RC400 Changer, continued

SERVICE AND REPAIR

DISASSEMBLING THE 45 RPM CENTERPOST

(See Figure 9)

To disassemble the centerpost for parts replacement etc., proceed as follows:

1. Remove screws (12) from underside of centerpost and lift up the centerpost cap (3). See figure 9. **CAUTION:** When the centerpost cap (3) is off, use extra care to keep from accidentally pushing up on the push-off adjusting shaft (15). If this shaft is pushed up, the slicer return springs (4) and slicers may fly off and be lost.

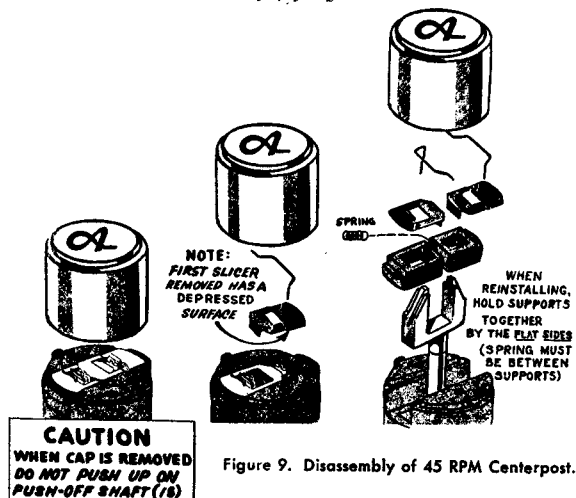

Figure 9. Disassembly of 45 RPM Centerpost.

2. Using a "long nose" pliers or tweezers, remove the slicer spring (4) which holds the top slicer (5) in place. Then remove the top slicer. (NOTE: This slicer has an offset. It must be removed first when disassembling and installed last when reassembling).
3. Remove the other slicer return spring and the bottom slicer (6).
4. Now, push up on the push-off adjusting shaft (15) until the record supports (8) come up over the top of the centerpost.
5. Grasp both record supports with the thumb and two forefingers and lift them off of the slicer cam (9A). Release record supports carefully so record support return spring (7) is not lost.
6. To remove the slicer cam and push-off assembly (9), remove the retaining ring (13) and the push-off return spring (11) from the underside of the centerpost and lift the assembly off from the top of the centerpost.

When assembling the centerpost, merely reverse the above procedure. When installing the record supports (8) and their return spring (7), place the spring between the record supports and compress the spring enough so the record supports can be slid down over the slicer cam (9A). When installing the slicers (5 and 6) be sure to install the flat slicer (5) first, and then the slicer with the offset.

REMOVING THE PICKUP ARM

(See Figure 5)

If the pickup arm must be removed for any reason, proceed as follows:

Important

Do NOT loosen the Allen set screw (34) in the pivot collar (33). If the screw is loosened, it will be necessary to make the set-down point adjustment.

1. Loosen the pivot locking screw (24) at the front of the pickup arm counterweight (21).
2. Turn the pivot screw (22) almost all the way out.
3. Move the pickup arm to the right to free the permanent pivot (part of the counterweight) from the pivot hole in the pivot collar (33). In early production changers, it may be necessary to use a slight twisting or "wiggling" motion to free the permanent pivot. When the permanent pivot has been freed, merely lift the pickup arm assembly up and off.

To reinstall the pickup arm assembly proceed as follows:

1. Slide the counterweight down on the pivot collar (33) until the permanent pivot point falls into the pivot hole in the pivot collar. In early production changers, it may be necessary to set the permanent pivot point in the pivot hole and then twist or "wiggle" the arm until the counterweight falls into the proper position.
2. Tighten the pivot screw (22) until it is tight and then back it off just enough so the pickup arm can move up and down freely.
3. Tighten the pivot locking screw (24).

REMOVING TURNTABLE (3B) AND THRUST BEARING ASSEMBLY (40)

To remove the turntable first place the speed change knob (19) in the "neutral" position. Being sure that the changer is not in change cycle, move the pickup arm away from the turntable. Then remove the retaining clip (37) on top of the turntable and lift the turntable straight up.

Before replacing the turntable, see that the drive wheel (36) is not against the centerpost socket and move the pickup arm as far as possible from the centerpost. Be sure the speed change knob (19) is in the "neutral" position.

No force is needed to seat the turntable.

Replace the turntable retaining clip (37) on the centerpost socket so that its "turned-up" ends are facing upward and away from the pickup arm.

The cork washers (39) and thrust bearing assembly (40) are removed by sliding them over the centerpost socket. Replace them in the order shown in figure 12.

LUBRICATION

Under normal operating conditions, the motor should never require oiling. Also, do NOT use oil on the 45 RPM centerpost and do NOT oil the roller on the reject lever (43). Any oil on this roller will be transferred to the drive wheel tire when the reject knob is moved to the "Rej" position, which might cause the drive wheel (36) to slip during change cycle. The

MANUAL OF 1950 MOST-OFTEN-NEEDED RADIO DIAGRAMS

drive shaft is fitted through an oilite bearing on the drive bracket (78); it also should not require oil.

The rest of the changer, however, should be lubricated with grease whenever it comes into the shop for repairs or adjustment. All pivot and friction points should be greased adequately but not excessively. A good automobile chassis grease may be used for this purpose.

RECORD CHANGER TROUBLE SHOOTING

Changer Will Not Trip Into Change Cycle.

1. Check adjustment of trip adjusting screw (75).
2. Check for broken, loose or weak trip tension spring (73).
3. Check for broken, missing or loose trip adjusting lock spring (74).
4. Check for oil or foreign material on the drive wheel tire (36).
5. Check to see that the drive bracket (78) is free (not binding) to pivot around drive bracket hub.
6. Check for broken cycle spring (76).

Changer Trips Into Change Cycle Before Finishing Record.

1. Check adjustment of trip adjusting screw (75). See paragraph under heading "Trip Adjustment."

Changer Will Not Reject.

1. Check for oil or foreign material on the drive wheel tire (36).
2. Check to see that the drive bracket (78) is free to pivot around the drive bracket hub.

Pickup Arm Does Not Set Down Properly.

1. Check set-down adjustment. See paragraph under "Adjustment of Set-down Point".

Records Do Not Drop to Turntable.

1. If 45 RPM records do not drop, adjust push-off adjusting shaft (15). See paragraph under heading "45 RPM Centerpost Adjustment".
2. If 33 RPM records do not drop, check the push-off adjustment. See paragraph under heading "Push-off Adjustment".

Changer Stalls in Change Cycle.

1. Check for parts binding.
2. If changer stalls with 45 RPM centerpost in place, adjust push-off adjusting shaft (15). See paragraph under heading "45 RPM Centerpost Adjustment".

Turntable Will Not Revolve When Changer Is Turned On.

1. Check position of speed change knob (19). If it is in "neutral" position, the turntable will not revolve.
2. Check for oil or foreign material on the tires of the compound idler wheel (47).
3. Check for broken idler wheel spring (50).

Admiral RC400 Changer, continued

The push-off shaft (16) and the bearing in the turntable hub may be lubricated with SAE No. 20 oil.

Care should be taken to prevent any of the lubricant from coming into contact with the drive or idler wheel tires. Also, be careful when using oil, not to let an excess seep into the felt of the turntable.

Changer Causes Rumble or Noise.

1. Check for broken or missing "float" springs (58).
2. Check for speed change knob shaft (19) rubbing against the edge of the cut-out in the changer pan.

Pickup Arm "Skips" Across Records.

1. Check to be sure that cabinet is level.
2. Check for worn needle.

CAUTIONS AND SERVICE HINTS

1. See that the rubber tires on both the drive wheel (36) and the compound idler wheel (47) are kept clean and free from oil, grease, dirt or any foreign material. Carbona or carbon tetrachloride may be used for cleaning these parts.
2. When handling the idler wheel or drive wheel, keep fingers and hands away from the rubber tires. Natural body oils on these parts may possibly cause slippage.
3. When the turntable is off, do NOT push the drive wheel (26) against the centerpost socket.
4. If the record changer is not going to be used for some time, place the speed-change knob (19) in the "neutral" position. This will eliminate the possibility of denting the idler wheel tires (47).
5. When disassembling the 45 RPM centerpost, do not push up on push-off adjusting shaft (15), just after removing the centerpost cap (3).
6. When removing the pickup arm, do NOT loosen the Allen set screw (34) in the pivot collar (33).
7. Do not oil the roller on the reject bracket (43). Oil will be transferred to the drive wheel tire (26) possibly causing slippage during change cycle.
8. When replacing the turntable retaining clip (37) be sure to slip it on with the "turned-up" ends facing upward.
9. When removing or reinstalling turntable, make sure that the record changer is not in change cycle and that the speed change knob (19) is in the "neutral" position.

MANUAL OF 1950 MOST-OFTEN-NEEDED RADIO DIAGRAMS

SOCKET VOLTAGE CHART

CROSLEY

MODELS 58XTA, 58XTW

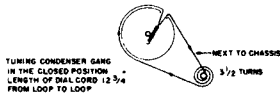

<p style="font-size: 0.8em; margin: 0;">OSC. GRID VOLTAGE CHART</p> <table style="width: 100%; border-collapse: collapse;"> <tr> <td style="font-size: 0.7em; padding: 2px;">MEDIUM WAVE</td> <td style="font-size: 0.7em; padding: 2px;">GANG CLOSED</td> <td style="font-size: 0.7em; padding: 2px;">-5. B</td> </tr> <tr> <td style="font-size: 0.7em; padding: 2px;">SHORTWAVE</td> <td style="font-size: 0.7em; padding: 2px;">GANG CLOSED</td> <td style="font-size: 0.7em; padding: 2px;">-4.2</td> </tr> </table>	MEDIUM WAVE	GANG CLOSED	-5. B	SHORTWAVE	GANG CLOSED	-4.2	<p style="font-size: 0.8em; margin: 0;">1st I.F. AMPLIFIER</p>	<p style="font-size: 0.8em; margin: 0;">DET.-AVG.-AF. AMPL.</p>	<p style="font-size: 0.8em; margin: 0;">RECTIFIER</p>
MEDIUM WAVE	GANG CLOSED	-5. B							
SHORTWAVE	GANG CLOSED	-4.2							
<p style="font-size: 0.8em; margin: 0;">CONVERTER</p>	<p style="font-size: 0.8em; margin: 0;">NOTES:</p> <ol style="list-style-type: none"> 1. BOTTOM VIEW OF TUBE SOCKETS. 2. VOLTAGE MEASURED WITH AN ELECTRONIC VOLTMETER FROM SOCKET LUG TO (B-) (PIN 5 OF 14H7). 3. LINE VOLTAGE 117 V. 60 CYCLE. 4. N.C. = NO CONNECTION. 5. W.J. = WIRING JUNCTION. 6. * = AC VOLTAGE 7. SOCKET VOLTAGE TOLERANCE ± 10% 		<p style="font-size: 0.8em; margin: 0;">OUTPUT</p>						

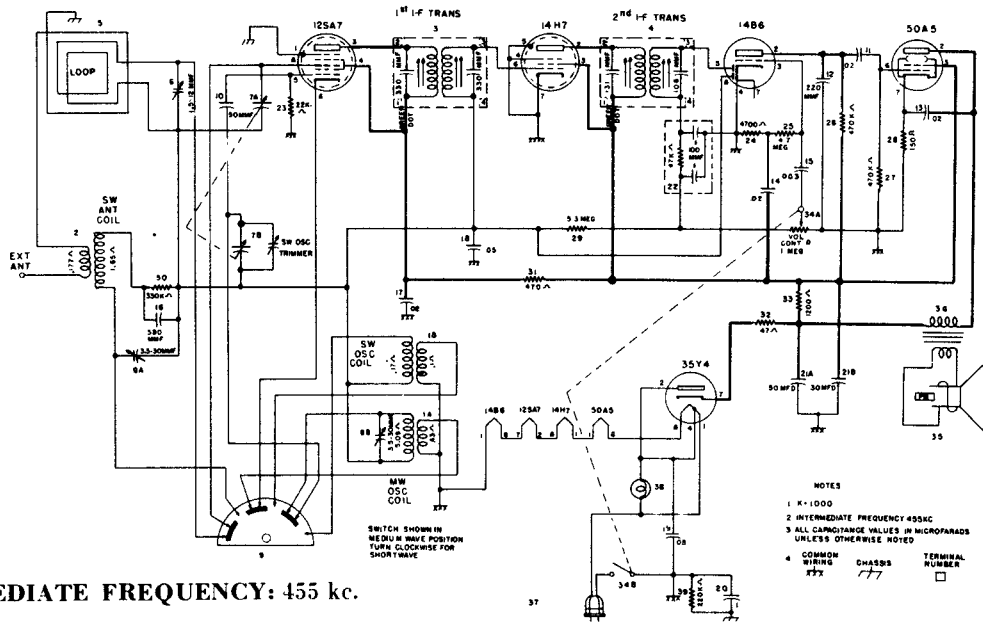

INTERMEDIATE FREQUENCY: 455 kc.

Item No.	Part No.	Description	Item No.	Part No.	Description
1A	AW-146155	Coil, Osc. M.W. } Two	26	39373-87	Resistor, 470,000 ohms 1/2 w.
1B	AW-146139	Coil, Osc. S.W. } Section	27	39373-87	Resistor, 470,000 ohms 1/2 w.
2	AW-146139	Coil, Ant. S.W.	28	39373-16	Resistor, 150 ohms 1/2 w.
3	C-139919-4	1st I.F. Trans.	29	39373-100	Resistor, 3.3 megohm 1/2 w.
4	C-139919-3	2nd I.F. Trans.	30	39373-84	Resistor, 330,000 ohms 1/2 w.
5	AC-135817	Loop & Back Assy.	31	39373-26	Resistor, 470 ohm, 1/2 w.
6	C-137219-2	Condenser, Trimmer, 1.5-12 mmf. (Part of 5)	32	39373-119	Resistor, 47 ohm 1 w.
7A	AW-144666	Condenser, Tuning } Two Section	33	39373-34	Resistor, 1,200 ohm 1/2 w.
7B	AW-144666	Condenser, Tuning } Variable	34A	39368-14	Control, Volume, 1.0 megohm
8A	AB-144617	Condenser, Trimmer, 3.5-30 mmf. } Two	34B	39369-1	Switch, Power (Part of 34A)
8B	AB-144617	Condenser, Trimmer, 3.5-30 mmf. } sect.	35	C-146133	Speaker
9	W-135808	Switch, Band Change	36	Part of Item 35	Transformer, Output
10	B-137498-11	Condenser, 50 mmf. 500 v. mica	37	C-132300-1	Cable & Plug, Power
11	39477-43	Condenser, .022 mfd., 600 v., paper	38	W-48858	Bulb (Dial), Type 47, 6.3 v., 15 amp.
12	B-137498-22	Condenser, 220 mmf., 500 v., mica	39	39373-80	Resistor, 220,000 ohm, 1/2 w.
13	39477-43	Condenser, .022 mfd., 600 v., paper		39232-1	Socket, tube
14	39477-43	Condenser, .022 mfd., 600 v., paper		C-136721	Background, Dial
15	39477-38	Condenser, .0033 mfd., 600 v., paper		D-132136-1	Cabinet (58XTA)
16	B-137498-14	Condenser, 580 mmf., 300 v., mica		AW-134738	Cabinet (58XTW)
17	39477-43	Condenser, .022 mfd., 600 v., paper		W-134667	Clip, Dial Pointer
18	39477-45	Condenser, .047 mfd., 600 v., paper		C-136962	Dial Face
19	39477-45	Condenser, .047 mfd., 600 v., paper		W-134882	Knob (58XTA)
20	39477-47	Condenser, .1 mfd., 600 v., paper		W-134883	Knob (58XTW)
21A	B-137649	Condenser, 30 mfd. 150 v. } Two sect.		B-134610	Lens, Dial
21B	B-137649	Condenser, 50 mfd. 150 v. } Elect.		B-134570	Pointer, Dial
22	B-142951-2	Condenser, Resistor		W-51071	Ring, Retaining (Dial Drive Shaft)
23	39373-60	Resistor, 22,000 ohms 1/2 w.		39220-32 CP	Screw, Chassis Mounting # 8-32 x 3/4"
24	39373-47	Resistor, 4,700 ohms 1/2 w.		W-134917	Shaft, Dial Drive
25	39373-102	Resistor, 4.7 megohms 1/2 w.		D-136565-4	Socket Assy., Dial Light
				W-51752	Spring, Dial Drive Cord
				W-132124 SB	Stud, Trimount

MANUAL OF 1950 MOST-OFTEN-NEEDED RADIO DIAGRAMS

CROSLEY

MODELS 10-102E, 10-103, 10-104W

Alignment Sequence	Signal Generator Output			Position of Dial Pointer	Adjust for Maximum Output
	Frequency in kc.	In Series with	To		
1	455	200 mmf.	High Side of Loop	1620	A & B
2	1620	*Radiated to Loop		1620	C
3	1400	*Radiated to Loop		1400	D

* Place signal generator output lead near the loop antenna.

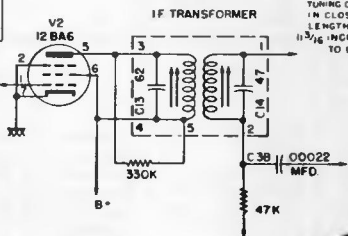
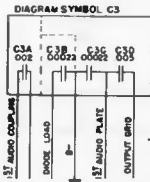
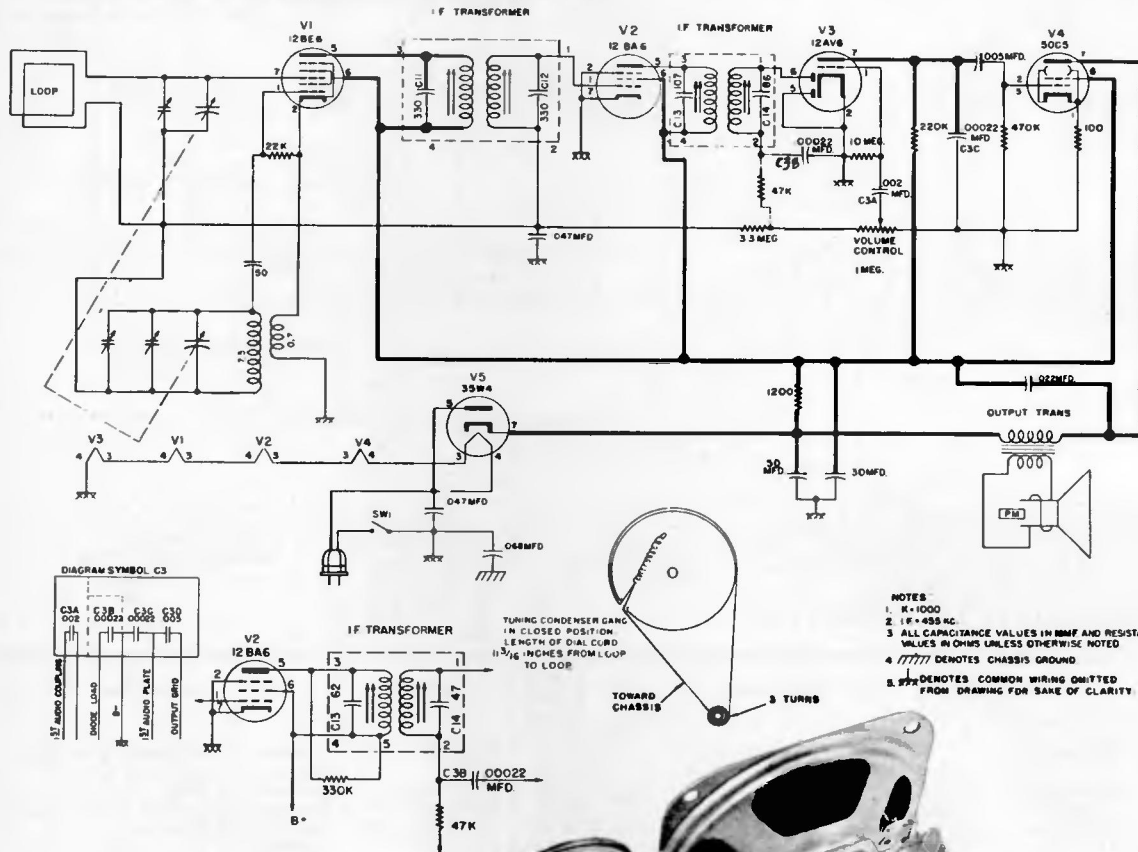

- NOTES
1. X=1000
 2. IF=455 KC.
 3. ALL CAPACITANCE VALUES IN MMF AND RESISTANCE VALUES IN OHMS UNLESS OTHERWISE NOTED
 4. // DENOTES COMMON WIRING OMITTED
 5. XXX DENOTES COMMON WIRING OMITTED FROM DRAWING FOR SAKE OF CLARITY

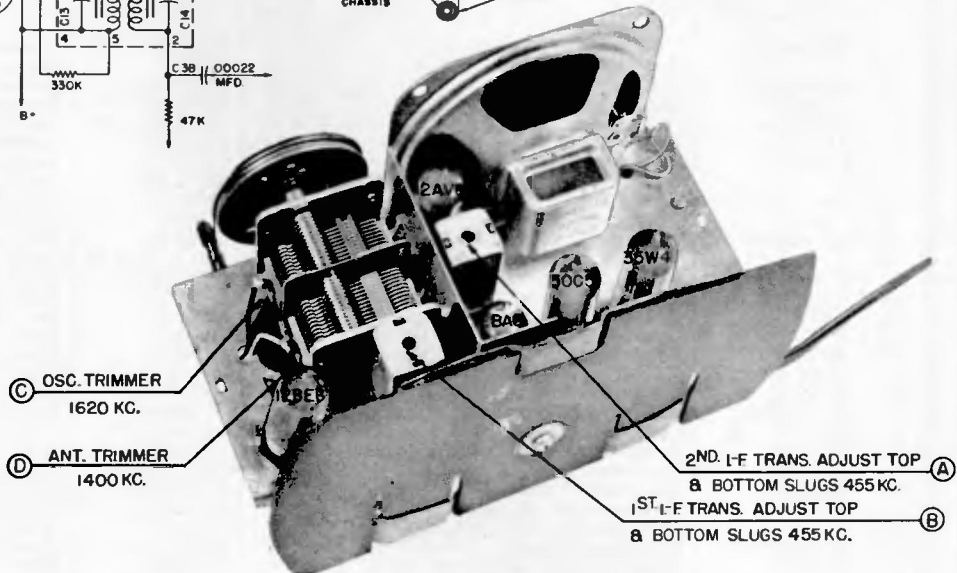

CHASSIS, TOP VIEW

MANUAL OF 1950 MOST-OFTEN-NEEDED RADIO DIAGRAMS

CROSLEY

FREQUENCY RANGE: 540 to 1600 kilocycles.
INTERMEDIATE FREQUENCY: 455 kc.
POWER SUPPLY: a.c.—d.c. or Battery.
VOLTAGE RATING: a.c.—d.c., 110 to 120 volts.
 "A" Battery, 41½ volts; "B" Battery, 90 volts.
POWER OUTPUT: 200 M.W. maximum.
POWER CONSUMPTION: 15 watts at 125 volts, 60 cycle.

MODELS: 10-310, 10-311, 10-313

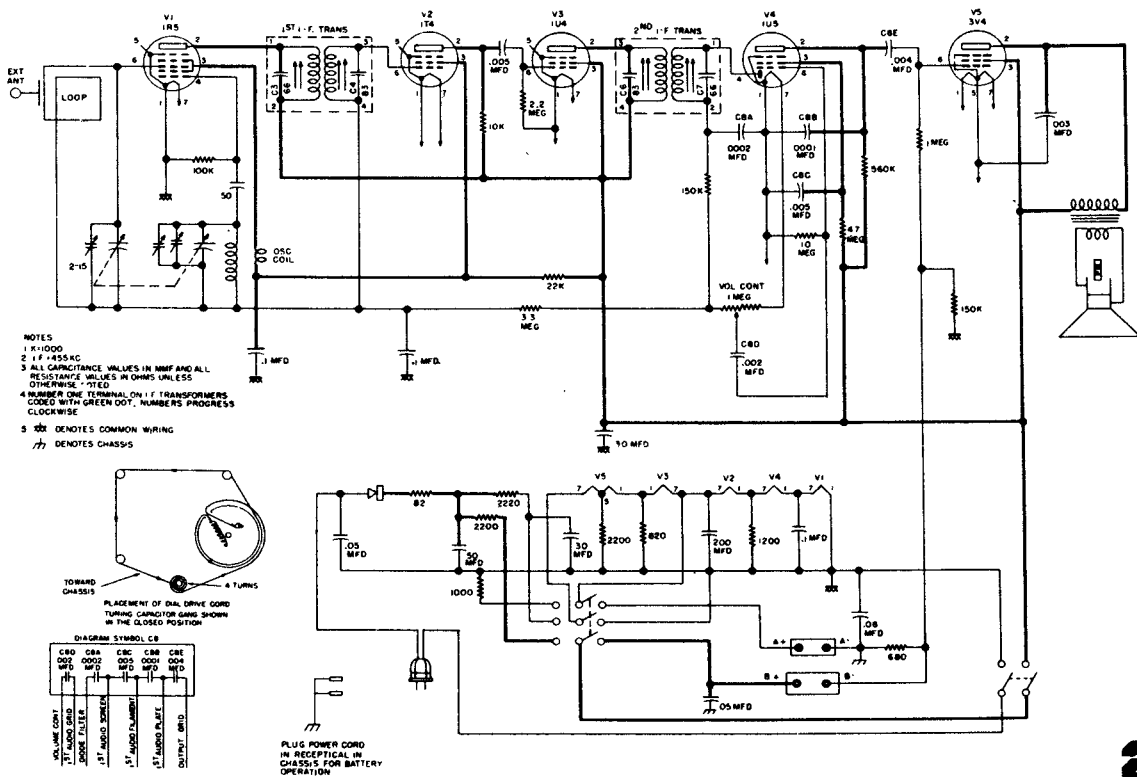
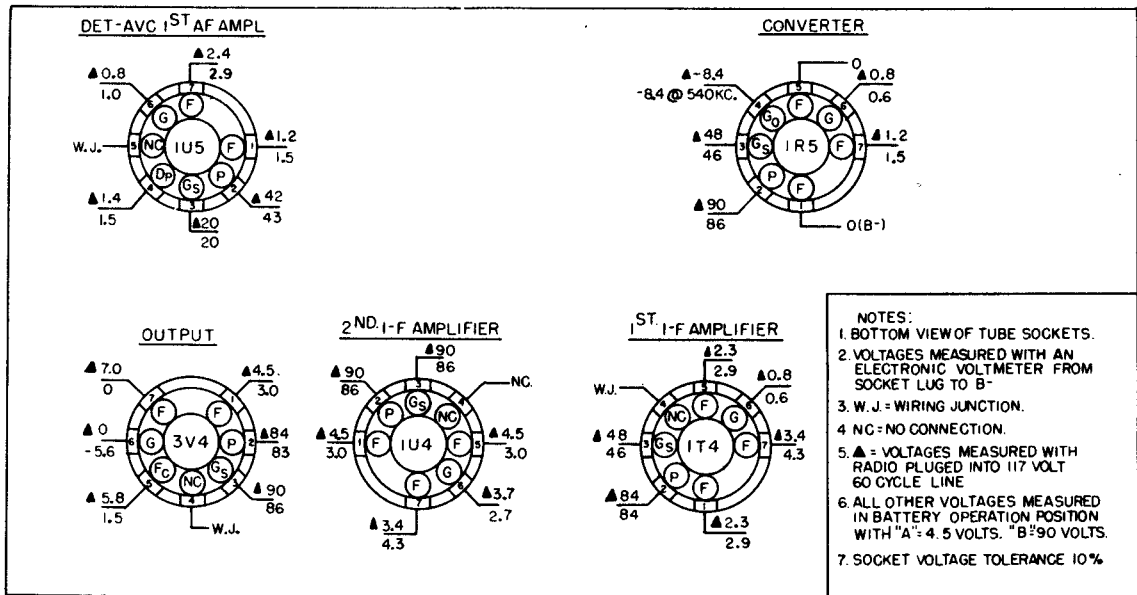

MANUAL OF 1950 MOST-OFTEN-NEEDED RADIO DIAGRAMS

CROSLEY

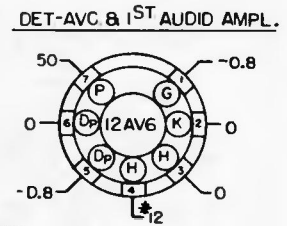
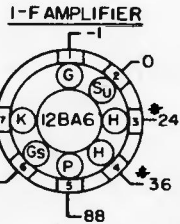
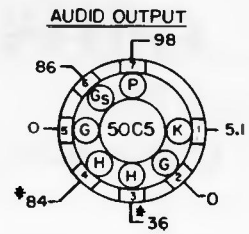
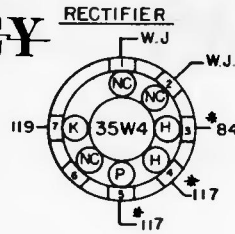
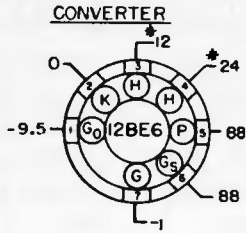

- NOTES:**
1. BOTTOM VIEW OF TUBE SOCKETS.
 2. VOLTAGES MEASURED WITH AN ELECTRONIC VOLTMETER FROM SOCKET LUG TO B-(PIN 7 OF 12BA6)
 3. MEASURED WITH THE VOLUME CONTROL AT MINIMUM & NO SIGNAL INTO THE LOOP, TUNING GANG CLOSED.
 4. W.J. = WIRING JUNCTION.
* = AC. VOLTAGES. NC = NO CONNECTION.
 5. LINE VOLTAGE = 117 V., 60~AC.
 6. SOCKET VOLTAGE TOLERANCE $\pm 10\%$

SOCKET VOLTAGE CHART

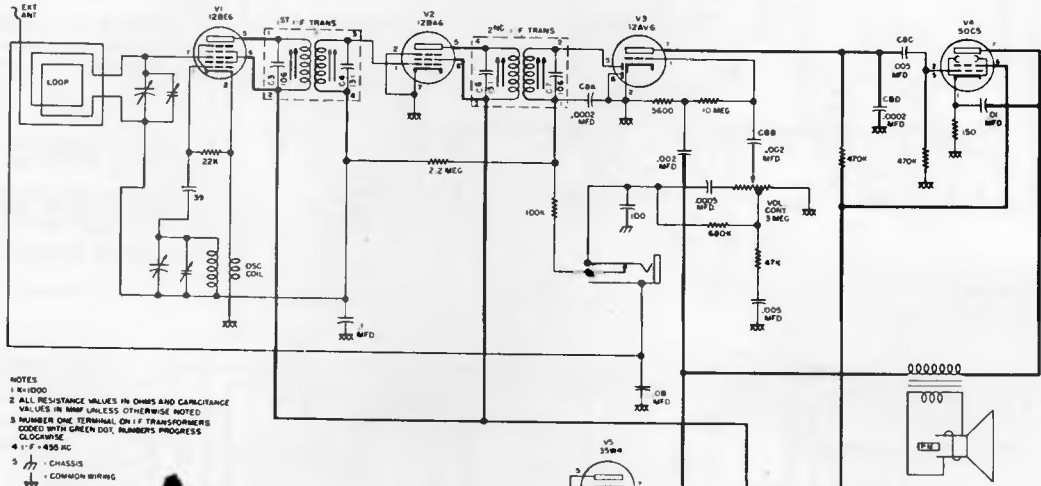

- NOTES:**
1. K=1000
 2. ALL RESISTANCE VALUES IN OHMS AND CAPACITANCE VALUES IN MMF UNLESS OTHERWISE NOTED
 3. NUMBER ONE TERMINAL ON I-F TRANSFORMERS CODED WITH GREEN DOT, NUMBERS PROGRESS CLOCKWISE
 4. 1-F = 450 KC
 5. CHASSIS
 6. COMMON WIRING

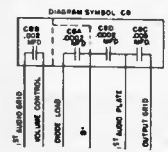
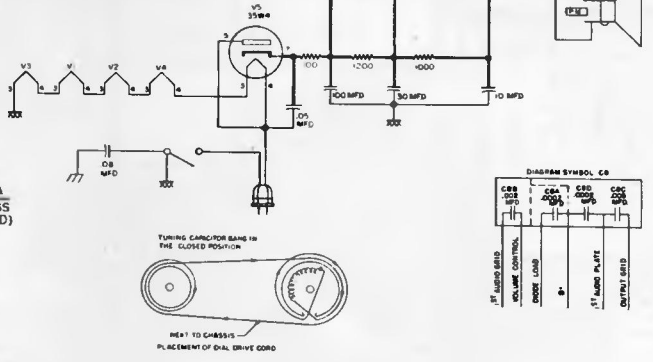
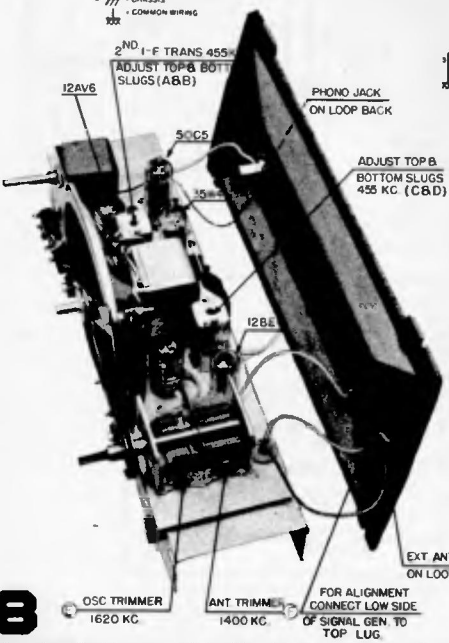

CROSLEY

MODELS 10-135, 10-136E, 10-137, 10-138, 10-139, 10-140

MANUAL OF 1950 MOST-OFTEN-NEEDED RADIO DIAGRAMS

CROSLLEY

MODEL 10-145M

Alignment Sequence	Signal Generator Output			Position of		Adjust for Maximum Output
	Frequency in kc.	In Series with	To	Radio-Phono Switch	Tuning Dial	
1	455	200 mmf.	Ant.	Counter-clockwise	Open	A & B (See Note 1)
2	1620	200 mmf	Ant.	Counter-clockwise	Open	C (See Note 1)
3	1400	*Radiated to Loop			Tune in Signal	D (See Note 2)

*Place signal generator output lead near the loop antenna.

Notes: 1. Disconnect loop antenna. Connect a 33,000 ohm resistor from pin 8 on 12SA7 tube socket to B-(pin 4 on 12SQ7 tube socket).
2. Remove 33,000 ohm resistor, connect loop antenna and place receiver chassis in cabinet.

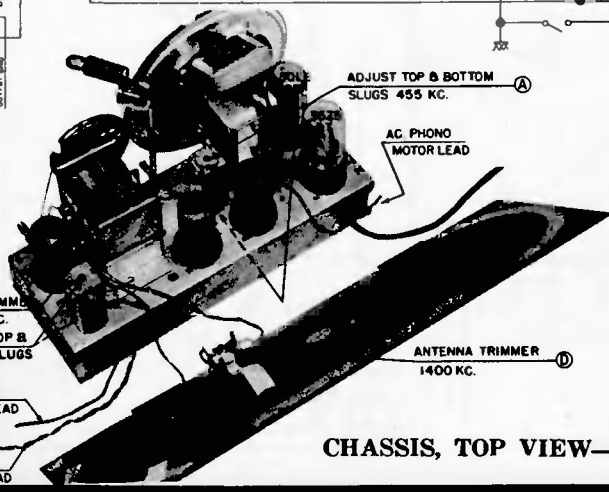
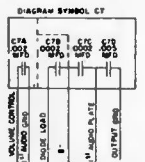
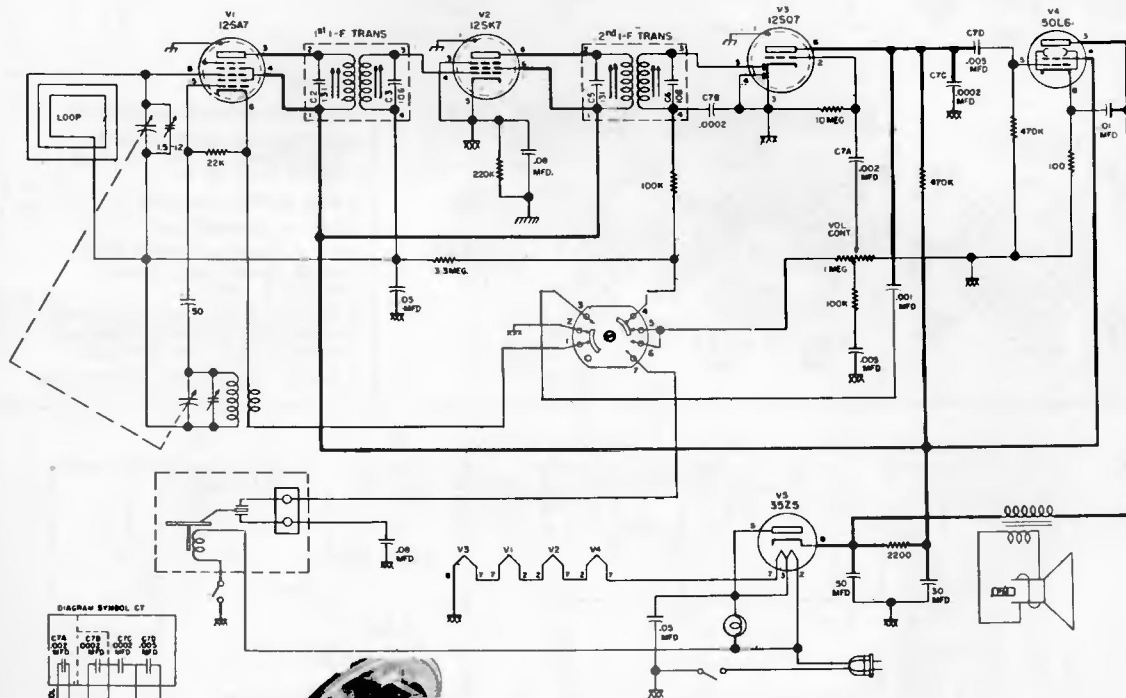

- NOTES
 1 K=1000
 2 I.F.=455 KC
 3 ALL CAPACITANCE VALUES IN MMF AND ALL RESISTANCE VALUES IN OHMS UNLESS OTHERWISE NOTED
 4 BAND CHANGE SWITCH SHOWN IN EXTREME COUNTER CLOCKWISE POSITION: SWITCH SEQUENCE: RADIO NORMAL TONE, RADIO BASS, PHONO BASS, PHONO NORMAL TONE
 5 Ⓢ DENOTES COMMON WIRING
 6 Ⓜ DENOTES CHASSIS
 TUNING CAPACITOR GANG IN THE CLOSED POSITION LENGTH OF DIAL CORD 13 1/2" FROM LOOP TO LOOP

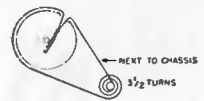

CHASSIS, TOP VIEW—MODEL 10-145M

MANUAL OF 1950 MOST-OFTEN-

CROSLEY

MODEL: 10-307M

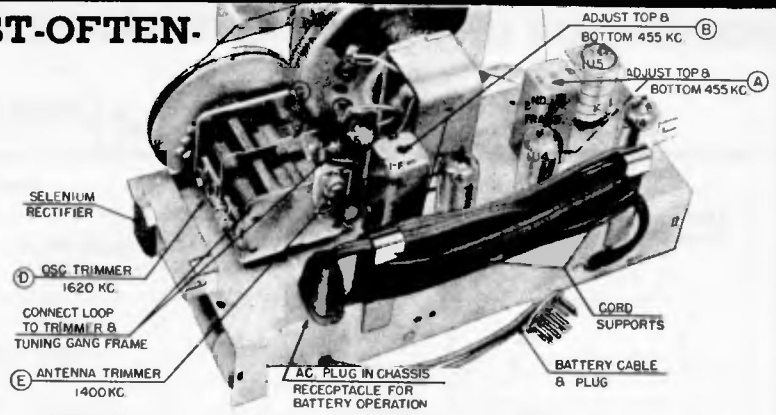

DET.-AVC. 1st. AF. AMPL.

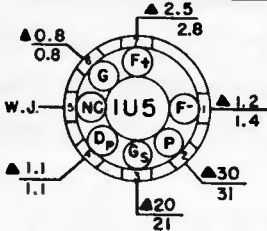

CONVERTER

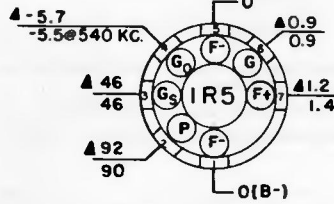

OUTPUT

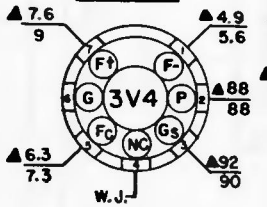

2nd. I-F. AMPLIFIER

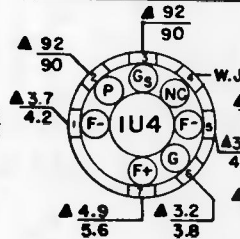

1st. I-F. AMPLIFIER

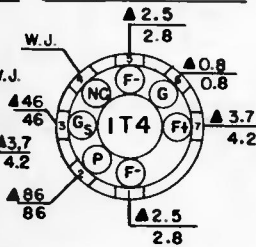

NOTES:

1. BOTTOM VIEW OF TUBE SOCKETS.
2. VOLTAGES MEASURED WITH AN ELECTRONIC VOLTMETER FROM SOCKET LUG TO 8-
3. W.J.= WIRING JUNCTION
4. NC= NO CONNECTION
5. A = VOLTAGES MEASURED WITH RADIO PLUGGED INTO 117 VOLT 60 CYCLE LINE
6. ALL OTHER VOLTAGES MEASURED IN BATTERY OPERATION POSITION WITH "A"= 9 VOLTS. "B"= 90 VOLTS.
7. SOCKET VOLTAGE TOLERANCE 10 %

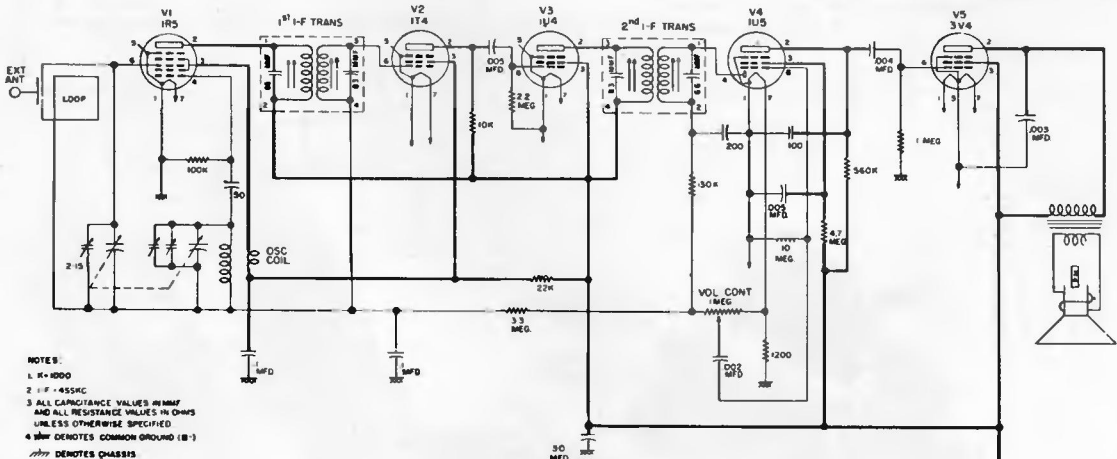

- NOTES:
1. E=4000
 2. I-F=555KC
 3. ALL CAPACITANCE VALUES IN MMF AND ALL RESISTANCE VALUES IN OHMS UNLESS OTHERWISE SPECIFIED
 4. 8W DENOTES COMMON GROUND (B-)
 - 8W DENOTES CHASSIS

PLUG POWER CORD IN RECEPTACLE IN CHASSIS FOR BATTERY OPERATION.

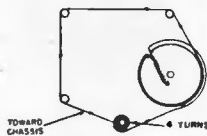

PLACEMENT OF DIAL DRIVE CORD TUNING CONDENSER GANG IN THE CLOSED POSITION LENGTH OF DIAL CORD 33 3/8 INCHES FROM LOOP TO LOOP

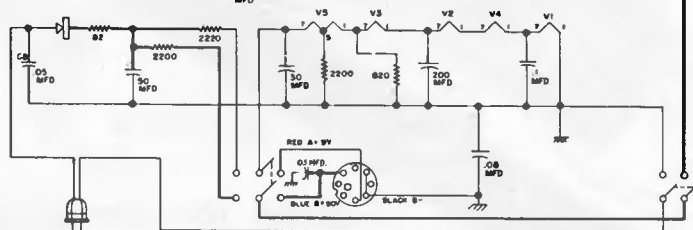

MANUAL OF 1950 MOST-OFTEN-NEEDED RADIO DIAGRAMS

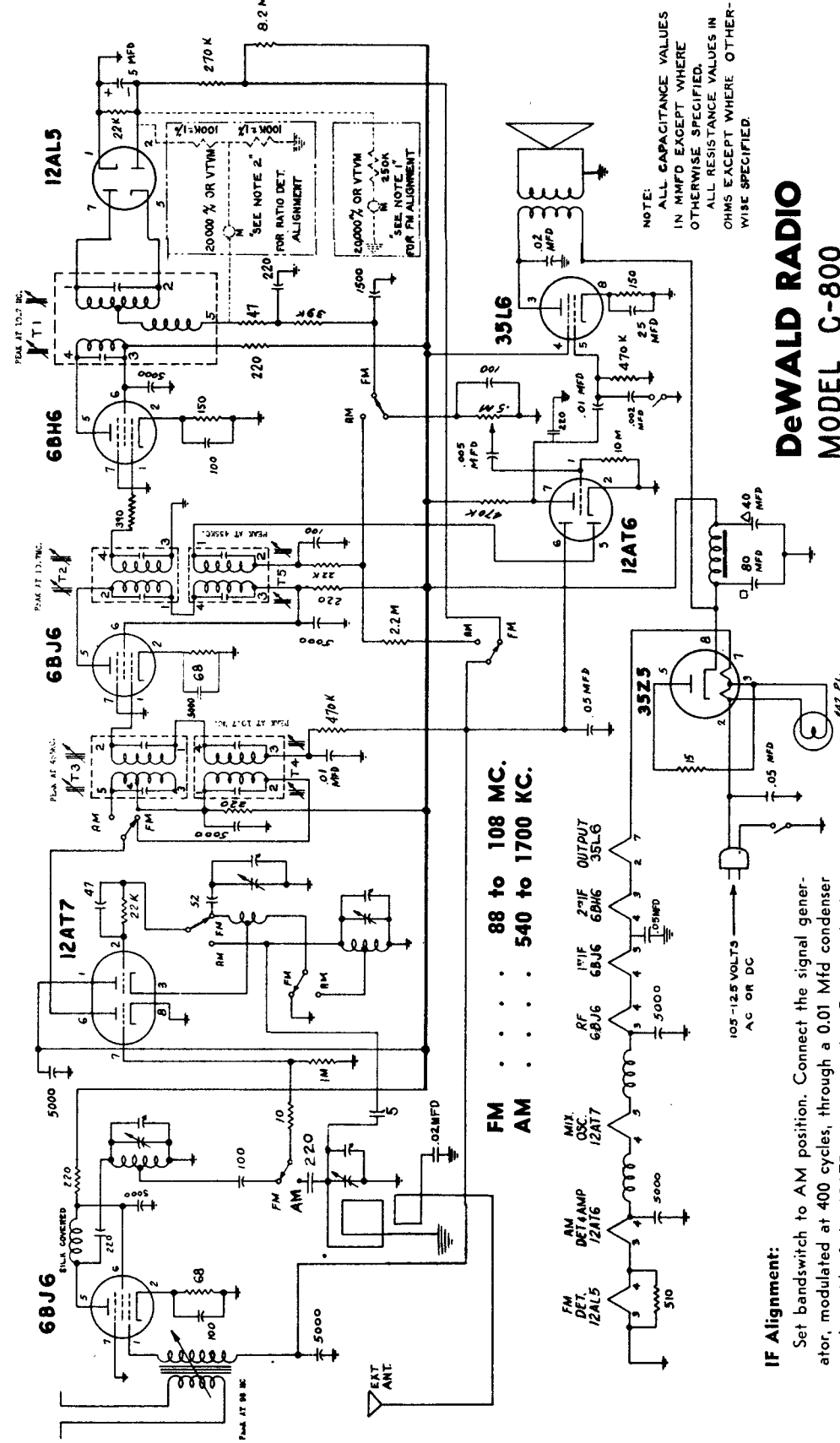

DeWald Radio MODEL C-800

VTVM meter as in note "1" of schematic diagram. Tune primary of T1, bottom slug, and both primary and secondary of T2 & T4 for maximum indication on meter. To align secondary of Ratio Detector Transformer connect meter as in note "2" of schematic diagram. Tune top slug through positive and negative indication and then slowly return until meter reads zero. This is in the center of the "S" curve.

NOTE:
 ALL CAPACITANCE VALUES
 IN MMFD EXCEPT WHERE
 OTHERWISE SPECIFIED.
 ALL RESISTANCE VALUES IN
 OHMS EXCEPT WHERE OTHER-
 WISE SPECIFIED.

NOTE 1:
 TO ALIGN T1-T5, TUNE PRIMARY OF T1, BOTTOM SLUG, AND
 INDICATOR OF METER.
 INDICATION OF METER.

NOTE 2:
 TO ALIGN SECONDARY OF RATIO DETECTOR TRANSFORMER,
 TUNE TOP SLUG THROUGH POSITIVE AND NEGATIVE
 INDICATION OF METER AND THEN SLOWLY RETURN UNTIL METER READS
 ZERO.

MANUAL OF 1950 MOST-OFTEN-NEEDED RADIO DIAGRAMS

DeWald Radio Model D-508

RANGE:

- B.C. Band 540-1700 Kilocycles
- S.W., Band 1 16.7 to 5.3 Mc.
- S.W., Band 2 5.5 to 1.9 Mc.

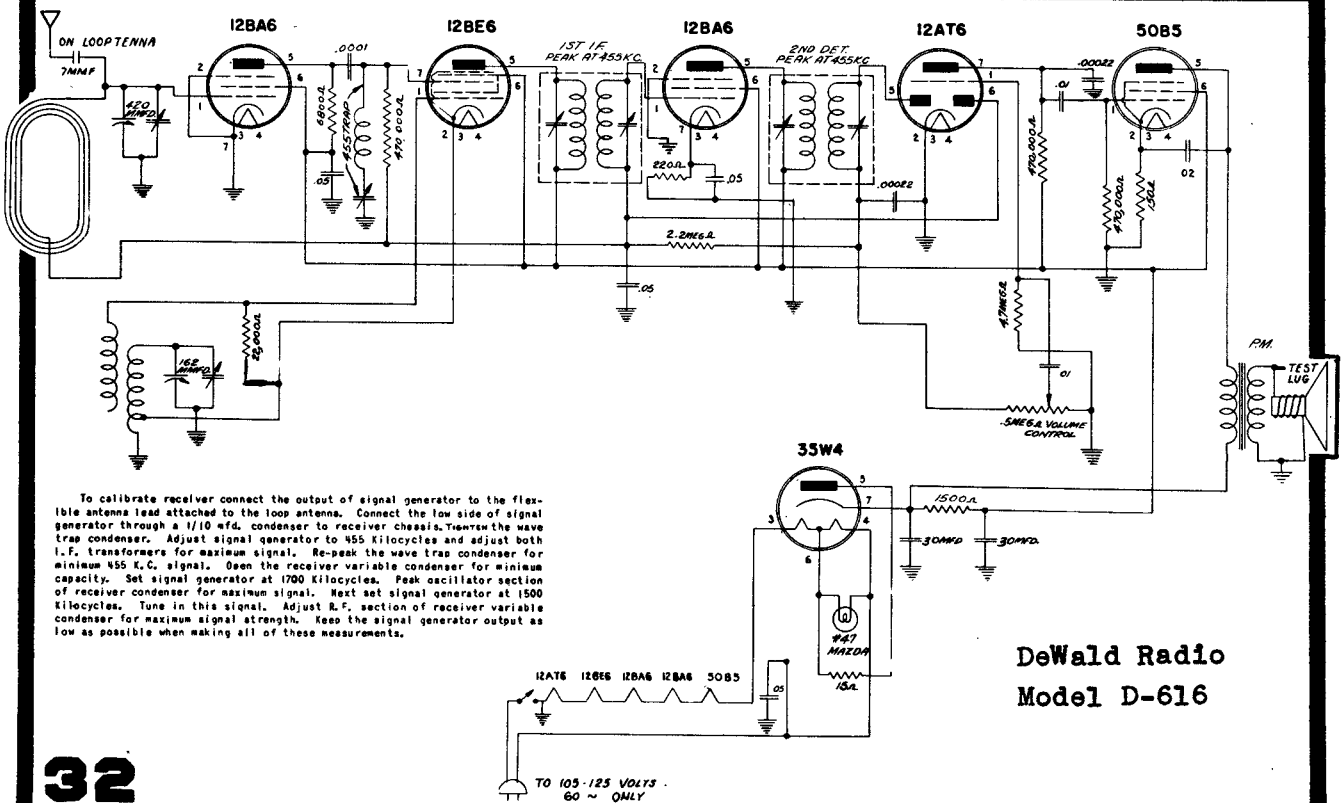
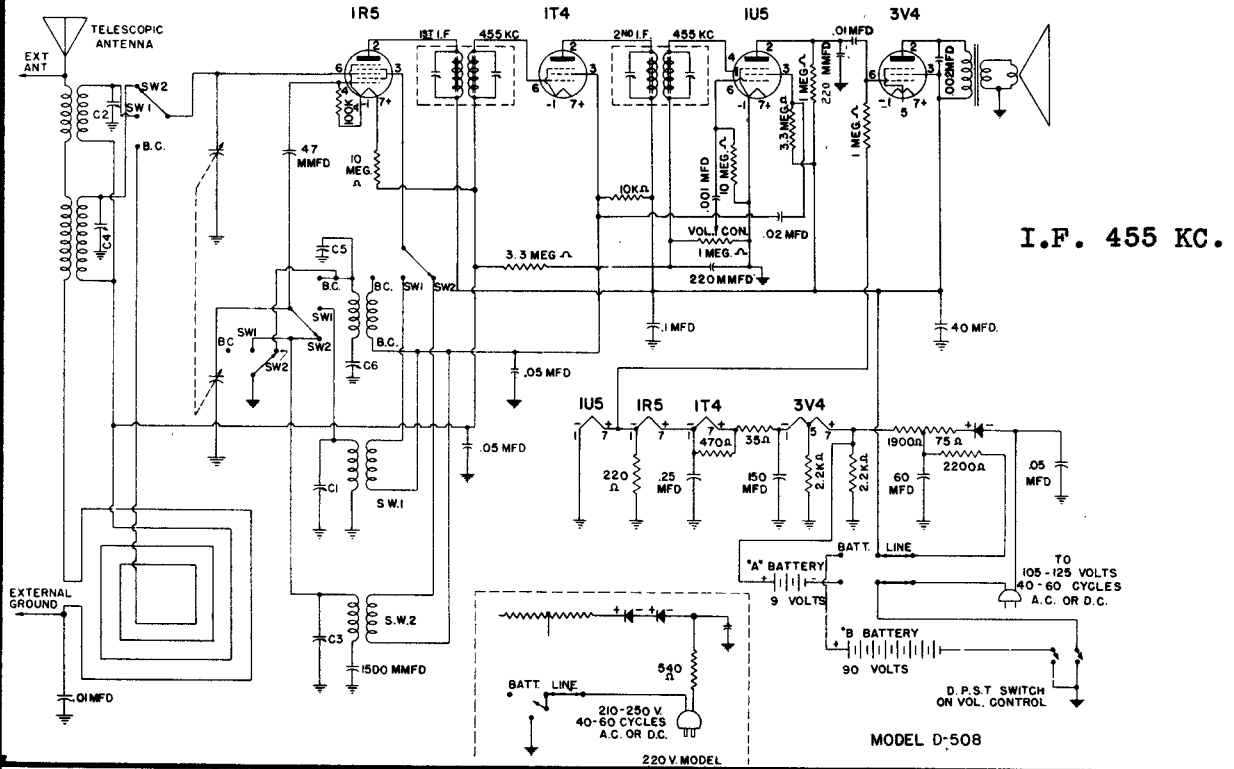

MANUAL OF 1950 MOST-OFTEN-NEEDED RADIO DIAGRAMS

Emerson Radio

MODELS: 579, 596

CHASSIS MODEL: 120034A

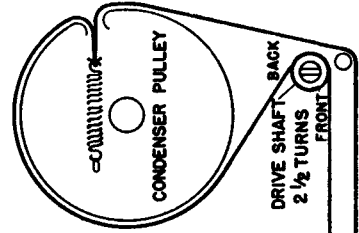
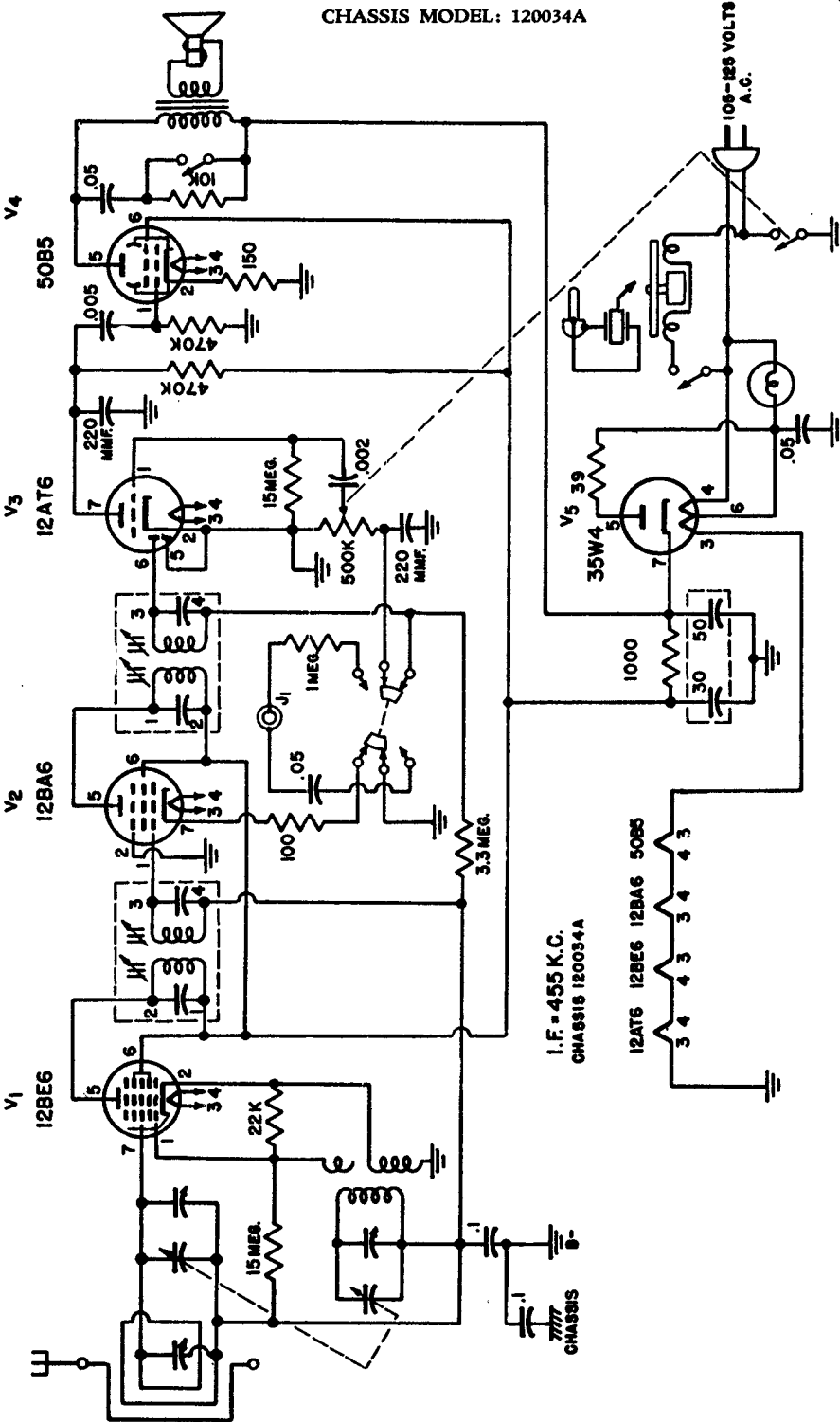

CONDENSER PULLEY
DRIVE SHAFT
2 1/2 TURNS
BACK
FRONT

VOLTAGE READINGS

SYMBOL	TUBE	PIN 1	PIN 2	PIN 3	PIN 4	PIN 5	PIN 6	PIN 7
V1	12BE6	-4.5	0	25 A.C.	13 A.C.	95	96	-1
V2	12BA6	-1	0	25 A.C.	38 A.C.	95	96	.4
V3	12AT6	-5	0	0	13 A.C.	0	96-3	42
V4	50B5	0	6.5	82 A.C.	38 A.C.	107	96	NC
V5	35W4	0	NC	82 A.C.	117 A.C.	110 A.C.	112 A.C.	115

D.C. voltage measurements are at 20,000 ohms-per-volt; a.c. voltages are measured at 1000 ohms-per-volt. Socket connections are shown as bottom views. Values are measured from socket pin to common negative. Line voltage maintained at 117 volts for voltage readings. Volume control at maximum; radio-phonograph switch in radio position; no signal applied for voltage measurements. Nominal tolerance on component values makes possible a variation of ± 15% in voltage and resistance readings.

POINTER
DIAL CORD DRIVE



MANUAL OF 1950 MOST-OFTEN-NEEDED RADIO DIAGRAMS

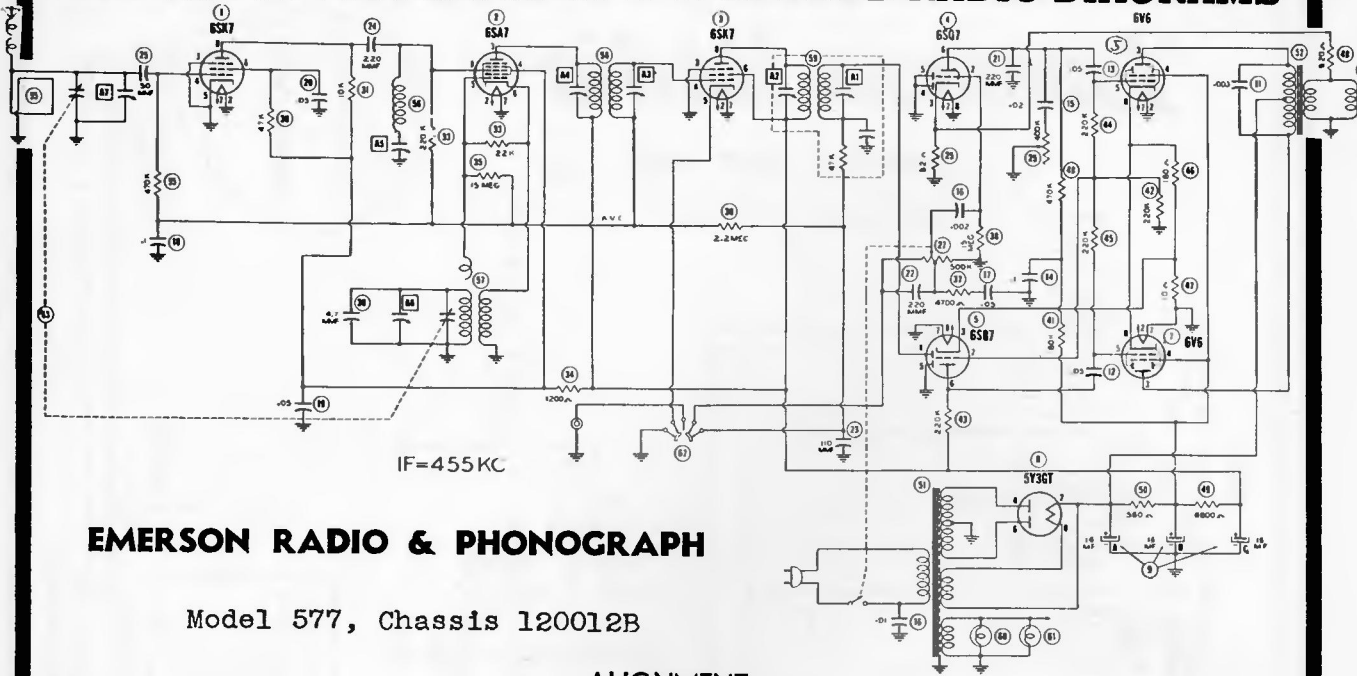

EMERSON RADIO & PHONOGRAPH

Model 577, Chassis 120012B

ALIGNMENT

Volume control should be at maximum position; output of signal generator should be no higher than necessary to obtain an output reading. Use an insulated alignment screwdriver.

	DUMMY ANTENNA	SIGNAL GENERATOR COUPLING	SIGNAL GENERATOR FREQUENCY	RADIO DIAL SETTING	OUTPUT METER	ADJUST	REMARKS
1	.1 mfd.	High side to Pin 8 (grid) of 6SA7. Low side to chassis.	455KC	Tuning cap. fully open.	Across voice coil.	A1, A2, A3, A4	Adjust for maximum output.
2	200 mmf.	High side to ext. ant. lead. Low side to chassis.	"	Tuning cap. fully closed.	"	A5	Adjust for minimum output.
3	200 mmf.	"	1620KC	Tuning cap. fully open.	"	A6	Adjust for maximum output
4	200 mmf.	"	1400KC	Tune for maximum output.	"	A7	" " "
5	200 mmf.	"	600KC	"	"		Adjust outside turn of loop for maximum output.

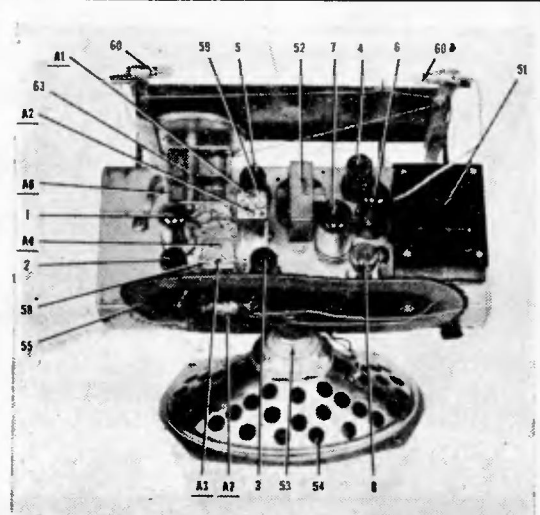
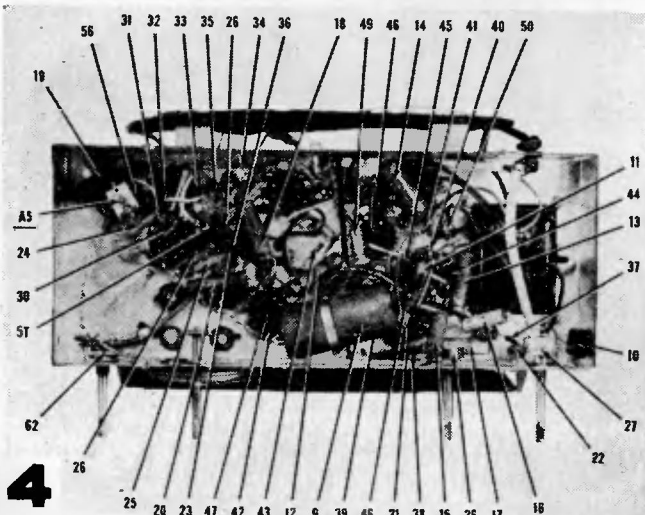

MANUAL OF 1950 MOST-OFTEN-NEEDED RADIO DIAGRAMS

Emerson Radio

MODELS: 581, 594, 595

CHASSIS MODELS: 120014A, 120071A

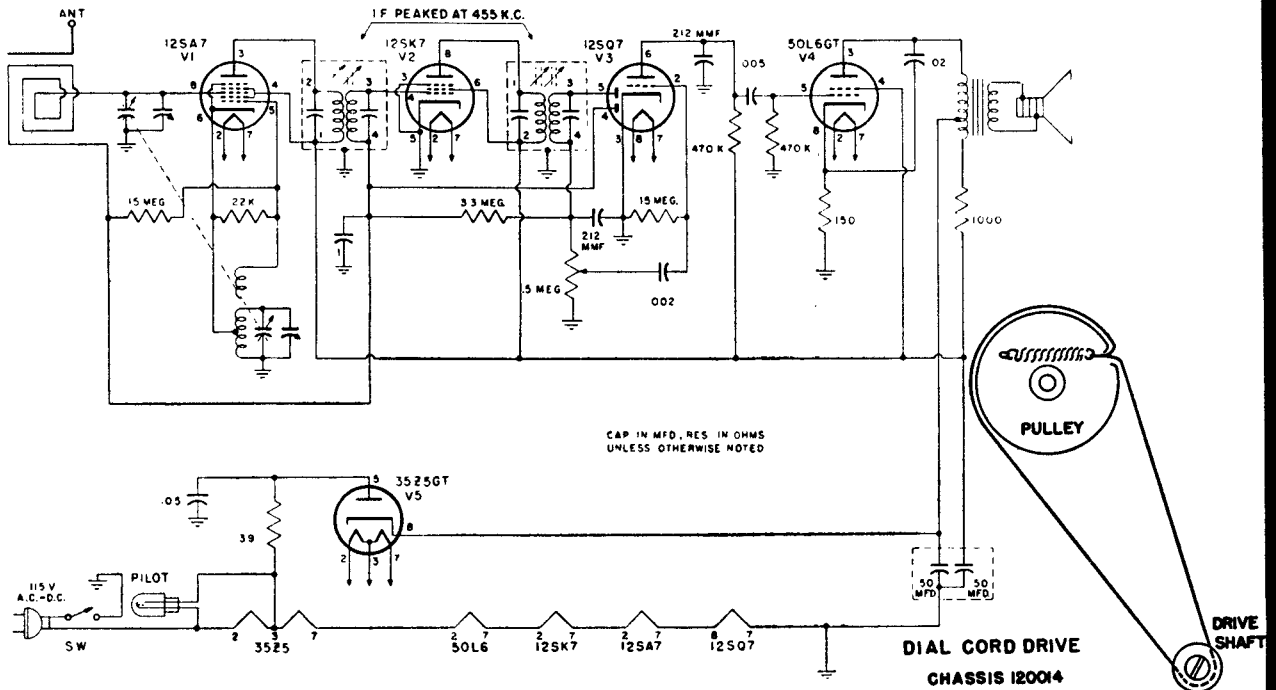

INSTRUCTIONS FOR VOLTAGE AND RESISTANCE READINGS

1. Voltage readings are in d.c. volts and resistance readings in ohms unless otherwise specified.
2. All measurements made with voltohmmyst.
3. Socket connections are shown as bottom views.
4. Measured values are from socket pin to common negative, unless otherwise specified.
5. Line voltage maintained at 117 volts for voltage readings.
6. Nominal tolerance on component values makes possible a variation of $\pm 15\%$ in voltage and resistance readings.
7. Volume control at maximum with no signal applied, for voltage measurements.

VOLTAGE READINGS

SYMBOL	TUBE	PIN 1	PIN 2	PIN 3	PIN 4	PIN 5	PIN 6	PIN 7	PIN 8
V1	12SA7GT	0	24 AC	95	95	-13	0	12 AC	-2
V2	12SK7GT	0	36 AC	0	-2	0	95	24 AC	95
V3	12SQ7GT	0	-1	0	-2	-5	55	0	12 AC
V4	50L6GT	NC	90 AC	110	95	0	NC	36 AC	6
V5	35Z5GT	NC	117 AC	112 AC	114	110 AC	NC	90 AC	114

RESISTANCE READINGS

SYMBOL	TUBE	PIN 1	PIN 2	PIN 3	PIN 4	PIN 5	PIN 6	PIN 7	PIN 8
V1	12SA7GT	0	48	1K*	1K*	24K	0	32	3 Meg.
V2	12SK7GT	0	60	0	3 Meg.	0	1K*	48	1K*
V3	12SQ7GT	0	15 Meg.	0	3 Meg.	.5 Meg.	540K*	0	32
V4	50L6GT	NC	110	160*	900*	.5 Meg.	NC	60	150
V5	35Z5GT	NC	148	145	0*	190	NC	110	0*

NC = no connection; K = kilohm; Meg. = megohm.

* Readings taken to pin 8 of V5.

MANUAL OF 1950 MOST-OFTEN-NEEDED RADIO DIAGRAMS

EMERSON RADIO

MODEL: 586

CHASSIS MODELS: 120023B, 120083B

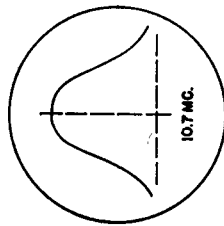
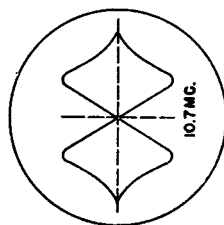
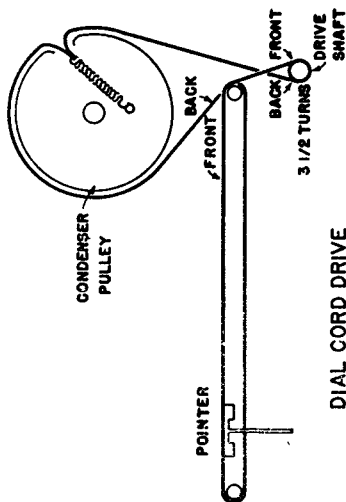

See page 37 for alignment facts.

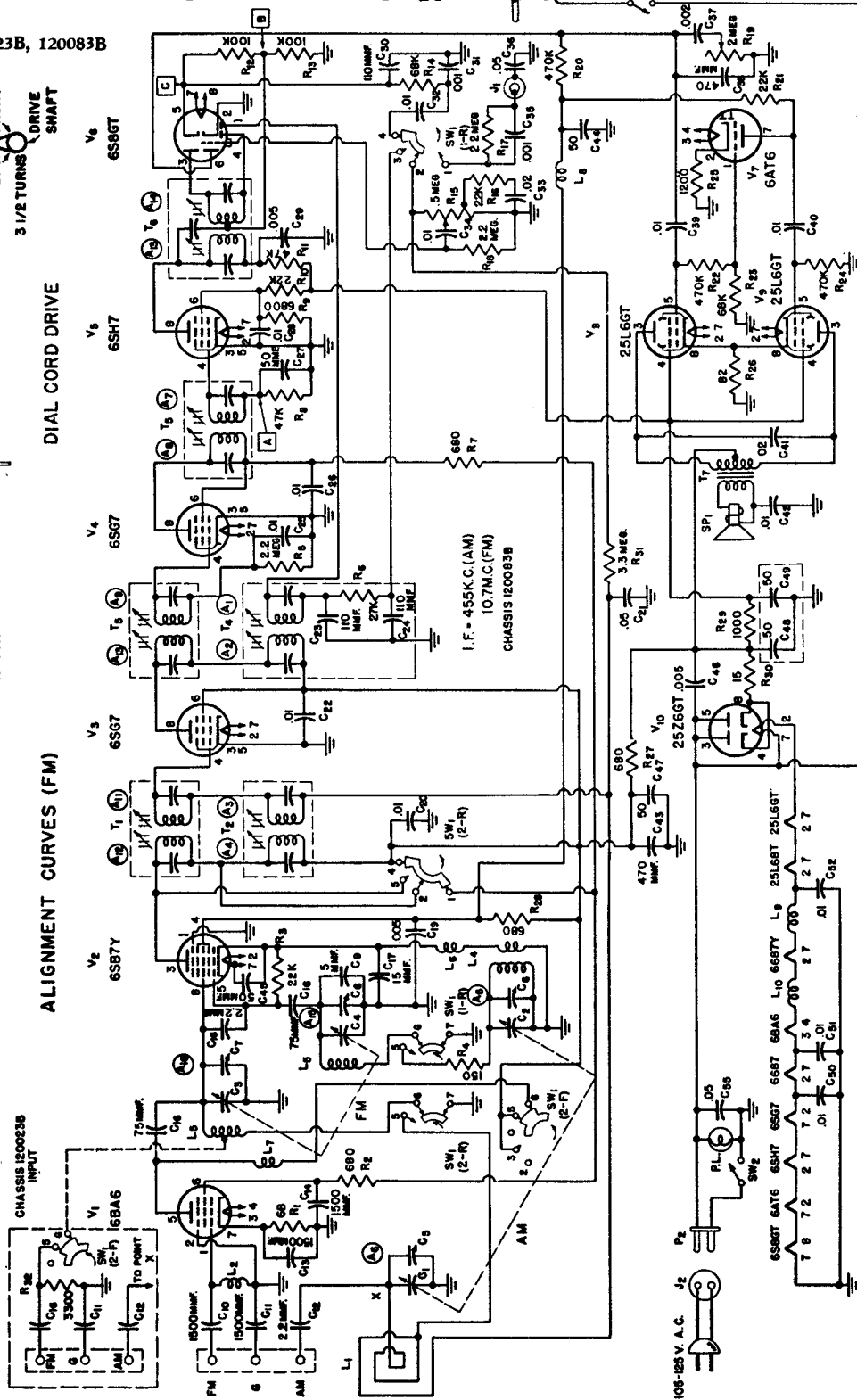
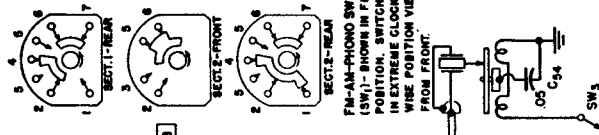

MANUAL OF 1950 MOST-OFTEN-NEEDED RADIO DIAGRAMS

Emerson Radio Model 586, Chassis 120023B, 120083B

Circuit diagram and curves on page 36.

ALIGNMENT INSTRUCTIONS

1. To position pointer, turn variable condenser fully closed and set pointer to reference mark on dial backplate at the low frequency end of the dial.
2. Volume control should be set at maximum position. The output of the signal generator should be no higher than necessary. Attenuate the signal input as alignment proceeds. Use an insulated alignment tool for all adjustments.
3. Use isolation transformer if available; otherwise connect a .1 mfd. condenser in series with low side of signal generator to chassis.

AM Alignment

DUMMY ANTENNA	SIGNAL GENERATOR COUPLING	SIGNAL GENERATOR FREQUENCY	BAND SWITCH POSITION	RADIO DIAL SETTING	OUTPUT METER	ADJUST	REMARKS	
1	.1 mfd.	High side to Pin 8 (grid) of 6SB7Y. Low side to chassis.	455 KC.	Broadcast	Tuning condenser fully open.	Across voice coil.	A1, A2, (Trans. T4), A3, A4, (Trans. T2).	Adjust for maximum output. Reduce dummy antenna to .001 mfd. if isolation trans. is not used.
2		Loop	1600 KC.	Broadcast	Tuning condenser fully open.	Across voice coil.	A5, (Trimmer cond. C6).	Form loop of several turns of wire. Radiate signal into receiver loop. Adjust for maximum output.
3		Loop	1400 KC.	Broadcast	Tune for max. output.	Across voice coil.	A6, (Trimmer cond. C5).	Adjust for maximum output.

FM I-F and Disc. Alignment Using AM Signal Generator and VTVM

DUMMY ANTENNA	SIGNAL GENERATOR COUPLING	SIGNAL GENERATOR FREQUENCY	BAND SWITCH POSITION	RADIO DIAL SETTING	CONNECT VTVM	ADJUST	REMARKS	
1	.01 mfd.	High side to Pin 4 (grid) of 6SG7 2nd i-f (V4). Low side to chassis.	10.7 mc. (Unmodulated)	Frequency modulation	Tuning condenser fully open.	Connect d.c. probe to point "A". Common to chassis.	A7, A8, (Trans. T5).	Adjust for maximum output.
2	.01 mfd.	High side to Pin 4 (grid) of 6SG7 1st i-f (V3). Low side to chassis.	10.7 mc. (Unmodulated)	Frequency modulation	Tuning condenser fully open.	Connect d.c. probe to point "A". Common to chassis.	A9, A10, (Trans. T3).	Adjust for maximum output.
3	.01 mfd.	High side to Pin 5 (osc. grid) of 6SB7Y conv. (V2). Low side to chassis.	10.7 mc. (Unmodulated)	Frequency modulation	Tuning condenser fully open.	Connect d.c. probe to point "A". Common to chassis.	A11, A12, (Trans. T1).	Adjust for maximum output.
4	.01 mfd.	High side to Pin 4 (grid) of 6SG7 2nd i-f (V4). Low side to chassis.	10.7 mc. (Unmodulated)	Frequency modulation	Tuning condenser fully open.	Connect d.c. probe to point "B". Common to chassis.	A13, (Trans. T6).	Adjust for maximum output.
5	.01 mfd.	"	10.7 mc. (Unmodulated)	Frequency modulation	Tuning condenser fully open.	Connect d.c. probe to point "C". Common to chassis.	A14, (Trans. T6).	Adjust for zero output. Continue with FM r-f alignment.

FM I-F and Disc. Alignment Using Sweep Signal Generator and Oscilloscope.

Use frequency modulated signal, with 60 cycle modulation and 450 kc. sweep. Use 120 cycle sawtooth sweep voltage in oscilloscope for horizontal deflection.

DUMMY ANTENNA	SIGNAL GENERATOR COUPLING	SIGNAL GENERATOR FREQUENCY	BAND SWITCH POSITION	RADIO DIAL SETTING	CONNECT OSCILLOSCOPE	ADJUST	REMARKS	
1	.01 mfd.	High side to Pin 4 (grid) of 6SG7 1st i-f (V3). Low side to chassis.	10.7 mc. (Unmodulated).	Frequency modulation	Tuning condenser fully open.	Vertical input to Point "A". Ground to chassis.	A7, A8, (Trans. T5), A9, A10, (Trans. T3).	Adjust for maximum output (height) and symmetry as per i-f alignment curve shown.
2	.01 mfd.	High side to Pin 5 (osc. grid) of 6SB7Y conv. (V2). Low side to chassis.	10.7 mc. (Unmodulated).	Frequency modulation	Tuning condenser fully open.	Vertical input to Point "A". Ground to chassis.	A11, A12, (Trans. T1).	Adjust for maximum output (height) and symmetry as per i-f alignment curve shown.
3	.01 mfd.	High side to Pin 4 (grid) of 6SG7 2nd i-f (V4). Low side to chassis.	10.7 mc. (Unmodulated).	Frequency modulation	Tuning condenser fully open.	Vertical input to Point "C". Ground to chassis.	A13, A14, (Trans. T6).	Alternately adjust A13 for maximum amplitude and A14 for maximum straightness of cross-over lines, with cross-over occurring at center of pattern as per discriminator alignment curve. Continue with FM r-f alignment.

FM R-F Alignment

DUMMY ANTENNA	SIGNAL GENERATOR COUPLING	SIGNAL GENERATOR FREQUENCY	BAND SWITCH POSITION	RADIO DIAL SETTING	CONNECT VTVM	ADJUST	REMARKS	
1	150 ohm resistor in series with each gen. lead.	High side to FM ent. term. Low side to chassis.	108.0 mc. (Unmodulated).	Frequency modulation	Tuning condenser fully open (108.0 mc.)	Connect d.c. probe to point "A". Common to chassis.	A15, (Trimmer cond. C8).	Adjust for maximum output.
2	"	"	106.0 mc.	Frequency modulation	Tune for maximum output.	"	A16, (Trimmer cond. C7).	Adjust for maximum output.

MANUAL OF 1950 MOST-OFTEN-NEEDED RADIO DIAGRAMS

EMERSON RADIO

MODELS: 590, 623

CHASSIS MODELS: 120101A, 120101B

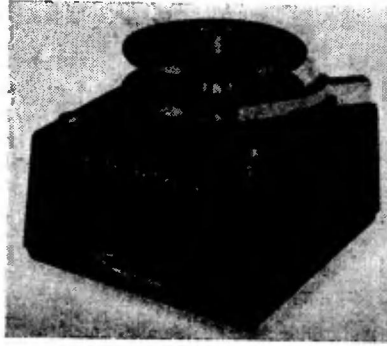

MODEL 590

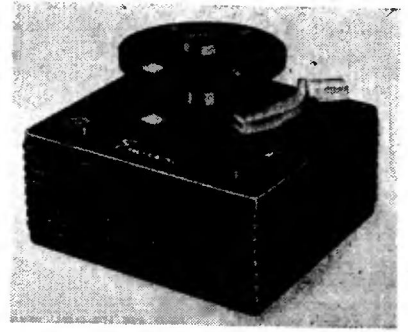

MODEL 623

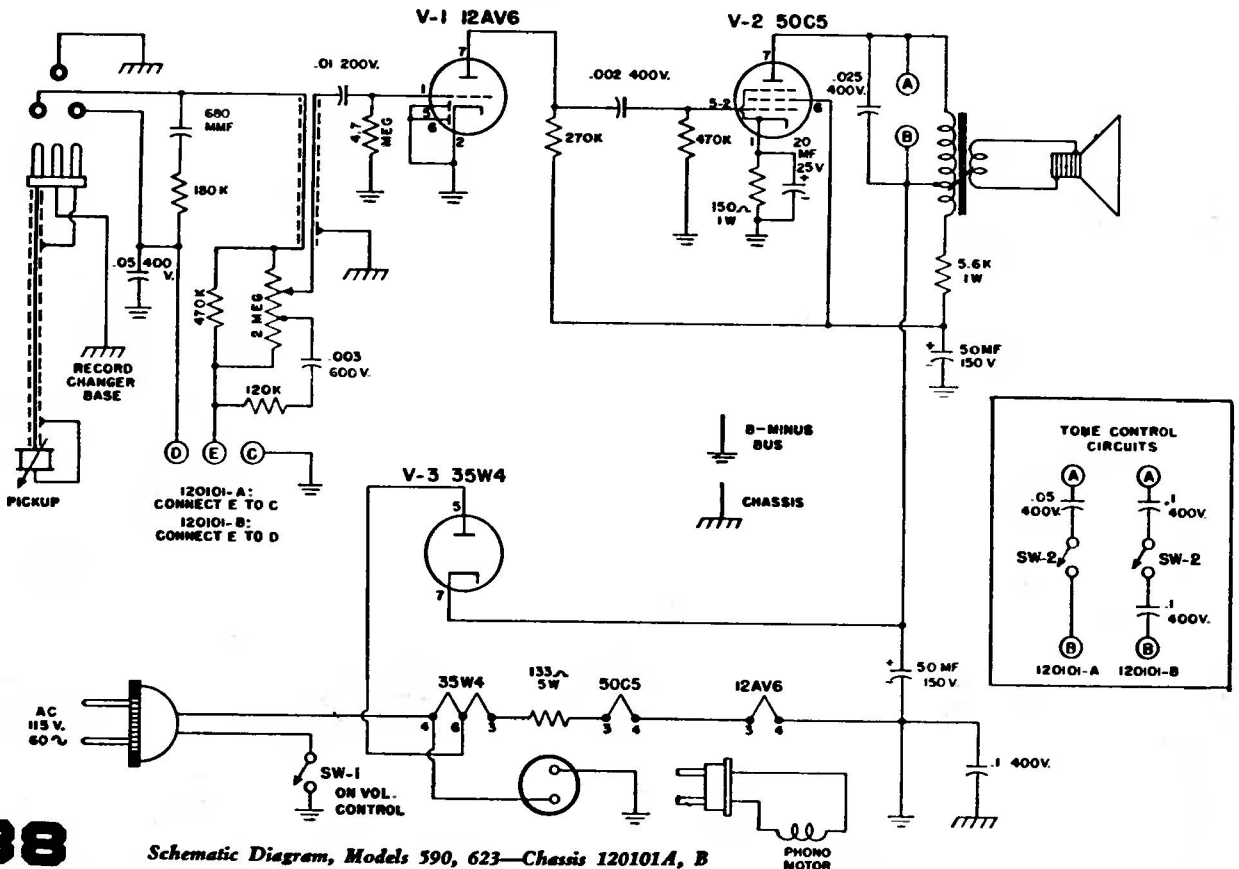
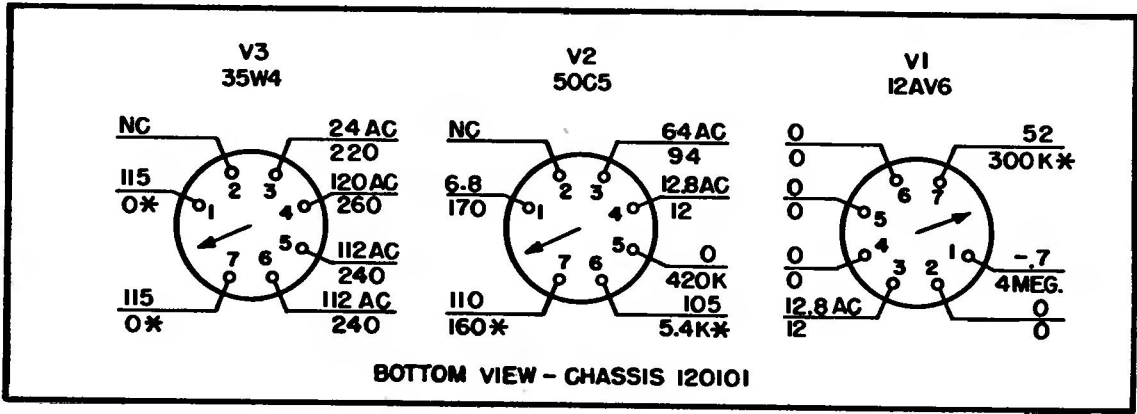

MANUAL OF 1950 MOST-OFTEN-NEEDED RADIO DIAGRAMS

Emerson Radio

MODEL: 591

CHASSIS MODEL: 120055A

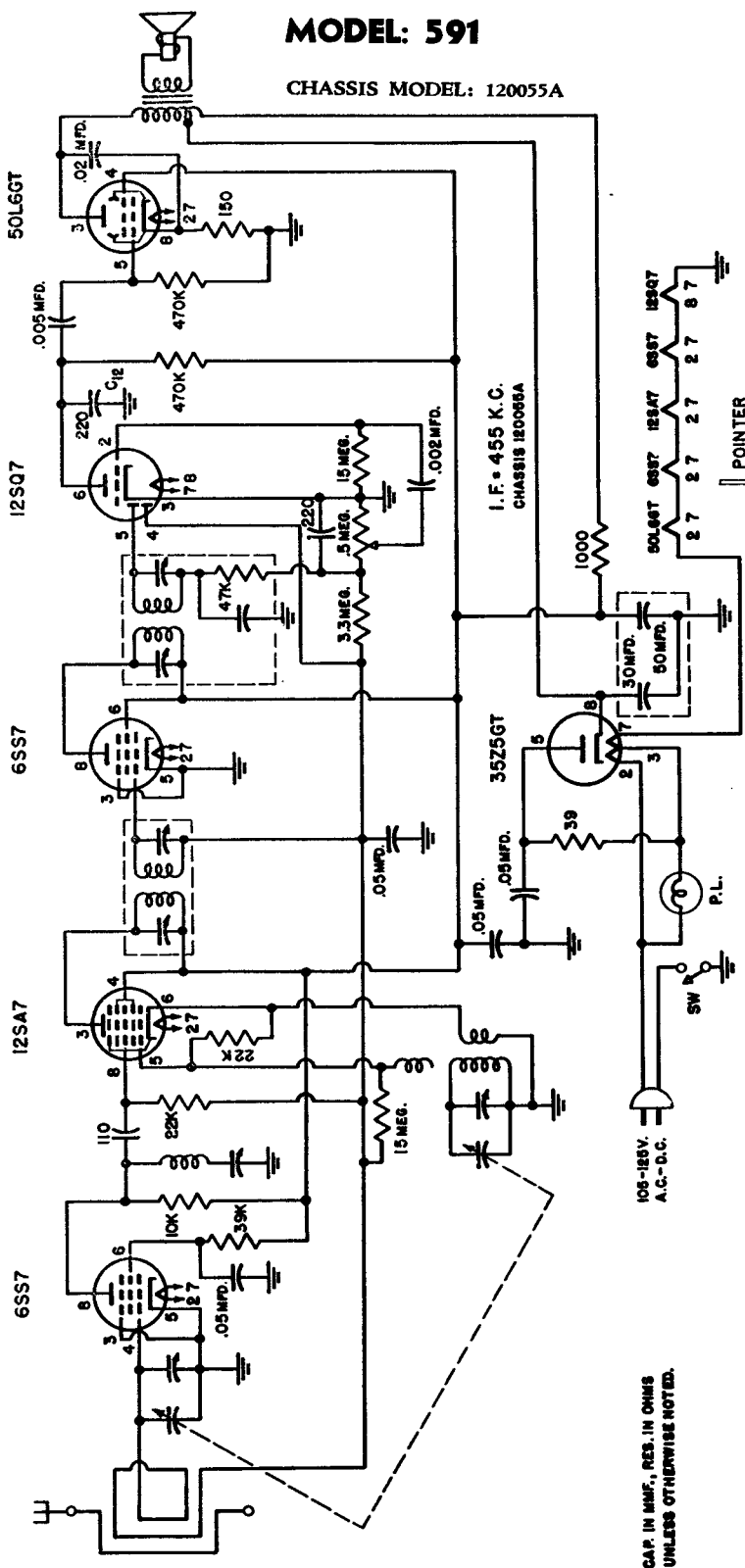

CAP. IN MFD., RES. IN OHMS UNLESS OTHERWISE NOTED.

I.F. = 455 K.C.
CHASSIS 180068A

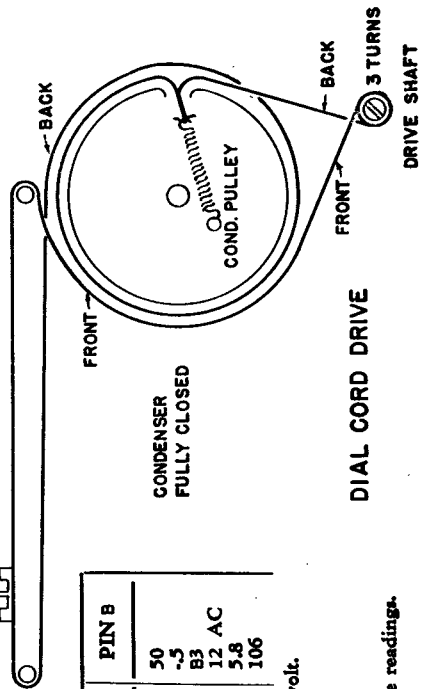

VOLTAGE READINGS

TUBE	PIN 1	PIN 2	PIN 3	PIN 4	PIN 5	PIN 6	PIN 7	PIN 8
6SS7	0	19 AC	0	-6	0	55	12 AC	50
12SA7	0	31 AC	B3	85	-4.5	0	19 AC	-5
6SS7	0	37 AC	0	-6	0	85	31 AC	B3
12SQ7	0	-9	0	-4	0	52	0	12 AC
50L6GT	NC	87 AC	100	B5	0	NC	37 AC	5.8
35Z5GT	NC	117 AC	113 AC	106	112 AC	NC	87 AC	106

D.c. voltage measurements are at 20,000 ohms-per-volt; a.c. voltages measured at 1000 ohms-per-volt.

Socket connections are shown as bottom views.

Measured values are from socket pin to common negative (chassis).

Line voltage maintained at 117 volts for voltage readings.

Nominal tolerance on component values makes possible a variation of ± 15% in voltage and resistance readings.

Volume control at maximum with no signal applied, for voltage measurements.

MANUAL OF 1950 MOST-OFTEN-NEEDED RADIO DIAGRAMS

Emerson Radio

MODELS: 599, 601

CHASSIS MODEL: 120075B

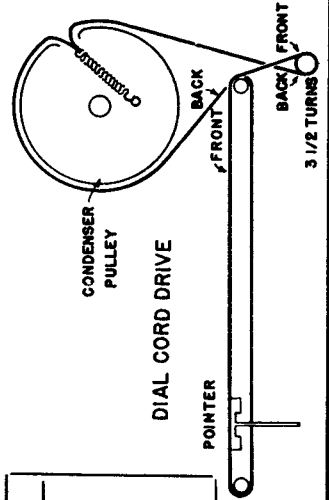

CAP. IN MC. RES. IN OHMS
UNLESS OTHERWISE NOTED

I.F. = 455 KC.

VOLTAGE READINGS

SYMBOL	TUBE	PIN 1	PIN 2	PIN 3	PIN 4	PIN 5	PIN 6	PIN 7	PIN 8
V1	6SS7	0	24AC	0	-1.2	0	64	29AC	54
V2	12SA7	0	41AC	98	64	-5	0	29AC	-1.5
V3	6SS7	0	48AC	0	-1.2	0	64	41AC	92
V4	12SQ7	0	-1	0	-4	0	58	0	12AC
V5	12SQ7	0	48AC	1.2	0	0	64	24AC	12AC
V6	35L6GT	0	83AC	120	100	0	96	83AC	7
V7	35L6GT	0	83AC	120	100	117AC	0	117AC	7
V8	117Z6GT	NC	117AC	117AC	125	NC	NC	0	125

All measurements made with voltohmmyst.

Socket connections are shown as bottom views.

Measured values are from socket pin to common negative, unless otherwise noted.

Line voltage maintained at 117 volts a.c. for voltage readings.

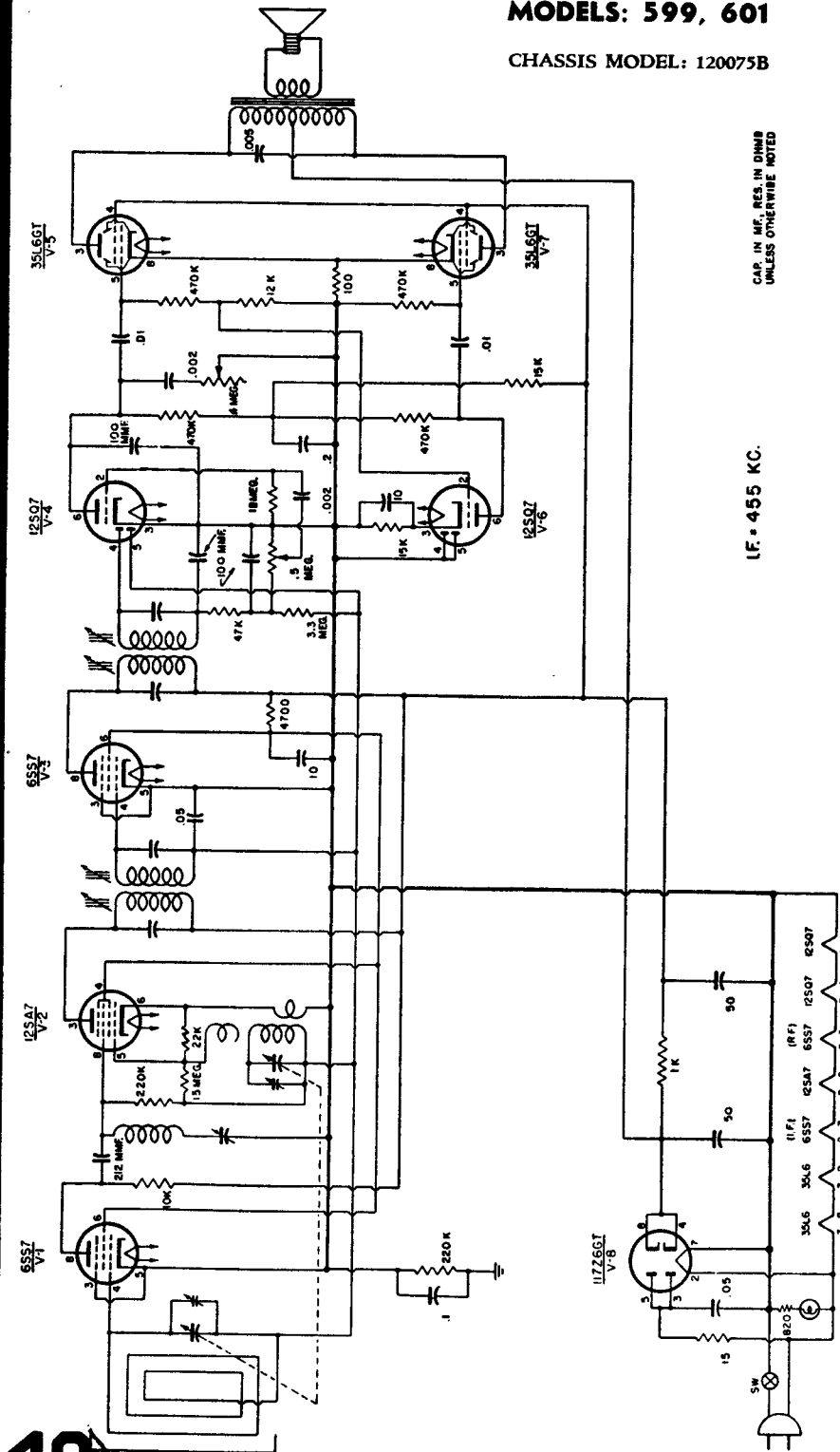

MANUAL OF 1950 MOST-OFTEN-NEEDED RADIO DIAGRAMS

EMERSON RADIO

MODEL: 602

CHASSIS MODELS: 120072A, 120082A

NOTE: This service note covers Model 602. The information contained herein applies equally to similar models, including Models 600 and 616.

TYPE: Single band FM superheterodyne

FREQUENCY RANGE: Frequency modulation band—88-108 megacycles

INSTRUCTIONS FOR VOLTAGE AND RESISTANCE READINGS

1. Voltage readings are in volts and resistance readings in ohms unless otherwise specified.
2. D.C. voltage measurements are at 20,000 ohms per volt; a.c. voltages are measured at 1000 ohms per volt.
3. Socket connections are shown as bottom views.
4. Measured values are from socket pin to common negative.
5. Line voltage maintained at 117 volts for voltage readings.
6. Nominal tolerance on component values makes possible a variation of $\pm 15\%$ in voltage and resistance readings.
7. Volume control at maximum, no signal applied, for voltage measurements.
8. Resistance readings in the B+ circuits may vary widely according to the condition of the filter condensers.

VOLTAGE READINGS

SYMBOL & TUBE	PIN 1	PIN 2	PIN 3	PIN 4	PIN 5	PIN 6	PIN 7	PIN 8	PIN 9
V1 (12BA7)	97 DC	0	0	38 AC	50 AC	0	0	0	96 DC
V2 (12BA6)	-0.5 DC	0	26 AC	38 AC	88 DC	88 DC	0	—	—
V3 (12BA6)	-0.5 DC	0	26 AC	13 AC	88 DC	88 DC	0	—	—
V4 (12S8GT)	-0.3 DC	0	-0.4 DC	0	-0.3 DC	45 DC	13 AC	0	—
V5 (35B5)	0	6 DC	50 AC	84 AC	110 DC	90 DC	NC	—	—
V6 (35W4)	0	NC	84 AC	117 AC	113 AC	NC	118 DC	—	—

NC denotes "no connection."

RESISTANCE READINGS

SYMBOL & TUBE	PIN 1	PIN 2	PIN 3	PIN 4	PIN 5	PIN 6	PIN 7	PIN 8	PIN 9
V1 (12BA7)	70 K	22 K	0	38	50	0	0	0	50 K
V2 (12BA6)	2.2 meg.	0	25	38	60 K	60 K	0	—	—
V3 (12BA6)	2.2 meg.	0	25	12	55 K	55 K	0	—	—
V4 (12S8GT)	660 K	0	32 K	0	660 K	610 K	12	0	—
V5 (35B5)	500 K	180	50	85	50 K	50 K	NC	—	—
V6 (35W4)	0	NC	85	120	160	NC	80 K	—	—

K denotes "kilohm" (1000 ohms); meg. means "megohm."

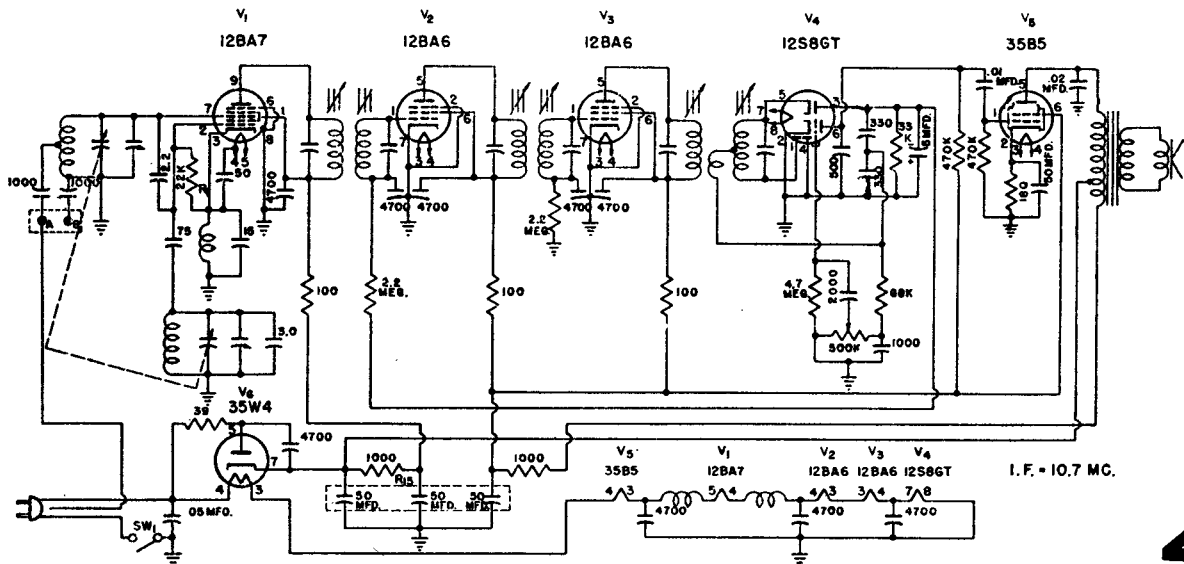

MANUAL OF 1950 MOST-OFTEN-NEEDED RADIO DIAGRAMS

EMERSON RADIO Model 605, Chassis 120076B

See page 43 for schematic diagram.

ALIGNMENT INSTRUCTIONS

To position pointer, turn variable condenser fully closed and set pointer to reference mark on dial backplate at the low frequency end of the dial. Volume control should be set at maximum position. The output of the signal generator should be no higher than necessary to obtain an output reading tenets the signal input as alignment proceeds. Use an insulated alignment tool for all adjustments. Use isolation transformer if available; otherwise connect a .1 mfd. condenser in series with low side of signal generator to chassis.

AM ALIGNMENT

DUMMY ANTENNA	SIGNAL GENERATOR COUPLING	SIGNAL GENERATOR FREQUENCY	BAND SWITCH POSITION	RADIO DIAL SETTING	OUTPUT METER	ADJUST	REMARKS
1 .1 mfd.	High side to Pin 7 (grid) of 12BA7. Low side to chassis.	455 KC.	Broadcast	Tuning condenser fully open.	Across voice coil.	A1, A2, (Trans. T4). A3, A4, (Trans. T2).	Adjust for maximum output. Reduce dummy antenna to .001 mfd. if isolation trans. is not used.
2	Loop	1600 KC.	Broadcast	Tuning condenser fully open.	Across voice coil.	A5, (Trimmer cond. C6).	Form loop of several turns of wire. Radiate signal into receiver loop. Adjust for maximum output.
3	Loop	1400 KC.	Broadcast	Tune for max. output.	Across voice coil.	A6, (Trimmer cond. C5).	Adjust for maximum output.

FM I-F and Disc. Alignment Using AM Signal Generator and VTVM

DUMMY ANTENNA	SIGNAL GENERATOR COUPLING	SIGNAL GENERATOR FREQUENCY	BAND SWITCH POSITION	RADIO DIAL SETTING	CONNECT VTVM	ADJUST	REMARKS
1 .01 mfd.	High side to Pin 1 (grid) of 12BA6 2nd i-f (V4). Low side to chassis.	10.7 mc. (Unmodulated)	Frequency modulation	Tuning condenser fully open.	Connect d.c. probe to point "A". Common to chassis.	A7, (Trans. T5).	Adjust for maximum output.
2 .01 mfd.	High side to Pin 1 (grid) of 12BA6 1st i-f (V3). Low side to chassis.	10.7 mc. (Unmodulated)	Frequency modulation	Tuning condenser fully open.	Connect d.c. probe to point "A". Common to chassis.	A8, A9, (Trans. T3).	Adjust for maximum output.
3 .01 mfd.	High side to Pin 2 (osc. grid) of 12BA7 conv. (V2). Low side to chassis.	10.7 mc. (Unmodulated)	Frequency modulation	Tuning condenser fully open.	Connect d.c. probe to point "A". Common to chassis.	A10, A11, (Trans. T1).	Adjust for maximum output.
4 .01 mfd.	High side to Pin 1 (grid) of 12BA6 2nd i-f (V4). Low side to chassis.	10.7 mc. (Unmodulated)	Frequency modulation	Tuning condenser fully open.	Connect d.c. probe to point "B". Common to chassis.	A12, (Trans. T6).	Adjust for maximum output.
5 .01 mfd.	"	10.7 mc. (Unmodulated)	Frequency modulation	Tuning condenser fully open.	Connect d.c. probe to point "C". Common to chassis.	A13, (Trans. T6).	Adjust for zero output. Continue with FM r-f alignment.

FM I-F AND DISC. ALIGNMENT USING SWEEP SIGNAL GENERATOR AND OSCILLOSCOPE. Use frequency modulated signal, with 60 cycle modulation and 450 kc sweep. Use 120 cycle sawtooth sweep voltage in oscilloscope for horizontal deflection.

DUMMY ANTENNA	SIGNAL GENERATOR COUPLING	SIGNAL GENERATOR FREQUENCY	BAND SWITCH POSITION	RADIO DIAL SETTING	CONNECT OSCILLOSCOPE	ADJUST	REMARKS
1 .01 mfd.	High side to Pin 1 (grid) of 12BA6 1st i-f (V3). Low side to chassis.	10.7 mc. (Unmodulated).	Frequency modulation	Tuning condenser fully open.	Vertical input to Point "A". Ground to chassis.	A7, A8, A9, (Trans. T5 and T3).	Adjust for maximum output (height) and symmetry as per i-f alignment curve shown (page 43).
2 .01 mfd.	High side to Pin 2 (osc. grid) of 12BA7 conv. (V2). Low side to chassis.	10.7 mc. (Unmodulated).	Frequency modulation	Tuning condenser fully open.	Vertical input to Point "A". Ground to chassis.	A10, A11, (Trans. T1).	Adjust for maximum output (height) and symmetry as per i-f alignment curve shown (page 43).
3 .01 mfd.	High side to Pin 1 (grid) of 12BA6 2nd i-f (V4). Low side to chassis.	10.7 mc. (Unmodulated).	Frequency modulation	Tuning condenser fully open.	Vertical input to Point "C". Ground to chassis.	A12, A13, (Trans. T6).	Alternately adjust A12 for maximum amplitude and A13 for maximum straightness of cross-over lines, with cross-over occurring at center of pattern as per discriminator alignment curve (page 43). Continue with FM r-f alignment.

FM R-F ALIGNMENT

DUMMY ANTENNA	SIGNAL GENERATOR COUPLING	SIGNAL GENERATOR FREQUENCY	BAND SWITCH POSITION	RADIO DIAL SETTING	CONNECT VTVM	ADJUST	REMARKS	
1	150 ohm resistor in series with each gen. lead.	High side to FM ant. term. Low side to chassis.	108.0 mc. (Unmodulated).	Frequency modulation	Tuning condenser fully open (108.0 mc.)	Connect d.c. probe to point "A". Common to chassis.	A14 (Trimmer cond. C8).	Adjust for maximum output.
2	"	"	106.0 mc.	Frequency modulation	Tune for maximum output.	"	A15 (Trimmer cond. C7).	Adjust for maximum output.

MANUAL OF 1950 MOST-OFTEN-NEEDED RADIO DIAGRAMS

EMERSON MODEL: 605

Alignment information given on page 42.

CHASSIS MODEL: 120076B

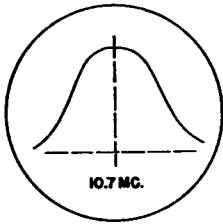

I.F. AND LIMITER

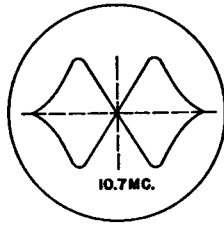

DISCRIMINATOR

Voltage and Resistance Readings

In charts below, voltage readings are in D.C. volts, resistance in ohms, unless otherwise specified. D.C. measured at 20,000 ohms/volt, A.C. at 1000 ohms/volt. Values measured from socket pin to common negative. Line at 117 v., volume at maximum, no signal applied.

VOLTAGE READINGS

SYMBOL	TUBE	PIN 1	PIN 2	PIN 3	PIN 4	PIN 5	PIN 6	PIN 7	PIN 8	PIN 9
V1	12BA6	0	0	80AC	67AC	76*	78*	.8*	—	—
V2	12BA7	100	-.5	0	67AC	55AC	0	-.5	0	95
V3	12BA6	-.2	0	55AC	43AC	93	98	0	—	—
V4	12BA6	0	0	43AC	30AC	70*	70*	.6*	—	—
V5	12AU6	-.4	0	30AC	18AC	50	50	0	—	—
V6	19T8	-.5	-.4	5.5*	18AC	0	-.8	0	-.5	33
V7	35B5	0	6	117AC	80AC	132	100	NC	—	—

NC denotes "no connection"; * for bandswitch in FM position only.

RESISTANCE READINGS

SYMBOL	TUBE	PIN 1	PIN 2	PIN 3	PIN 4	PIN 5	PIN 6	PIN 7	PIN 8	PIN 9
V1	12BA6	0	0	16	12	65K*	65K*	66	—	—
V2	12BA7	65K	24K	1	56	75	0	0	0	65K
V3	12BA6	2.8 meg.	0	56	44	65K	65K	0	—	—
V4	12BA6	68	0	44	32	65K	65K	68	—	—
V5	12AU6	100K	0	32	20	65K	65K	0	—	—
V6	19T8	90K	90K	150K	20	0	1 meg.	0	4 meg.	550K
V7	35B5	400K	190	112	80	65K	65K	NC	—	—

K—Kilohms; meg.—megohms.

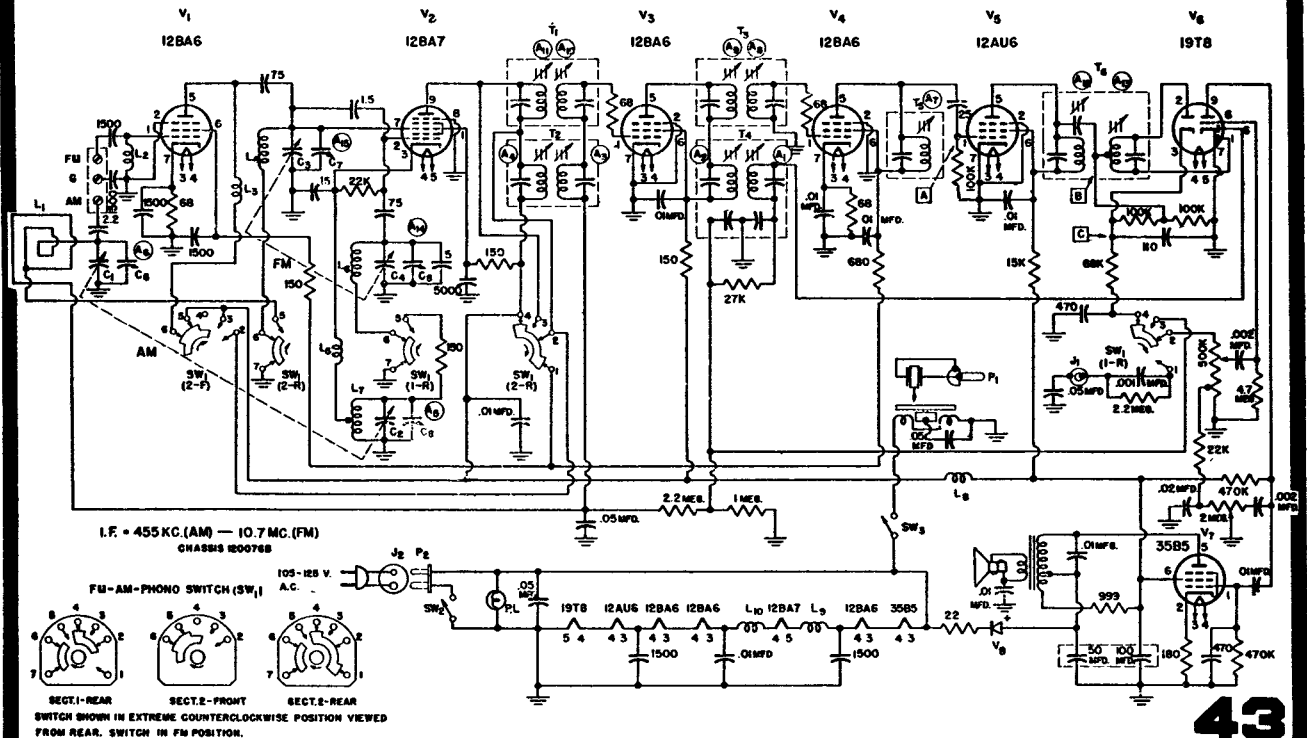

MANUAL OF 1950 MOST-OFTEN-NEEDED RADIO DIAGRAMS

Emerson

MODELS: 652, 653

CHASSIS: 120032B, 120080B

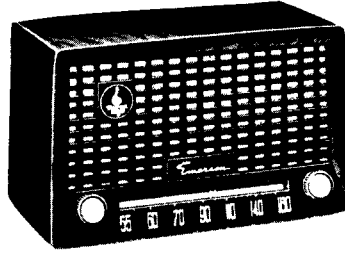

MODEL 653
Chassis 120080B

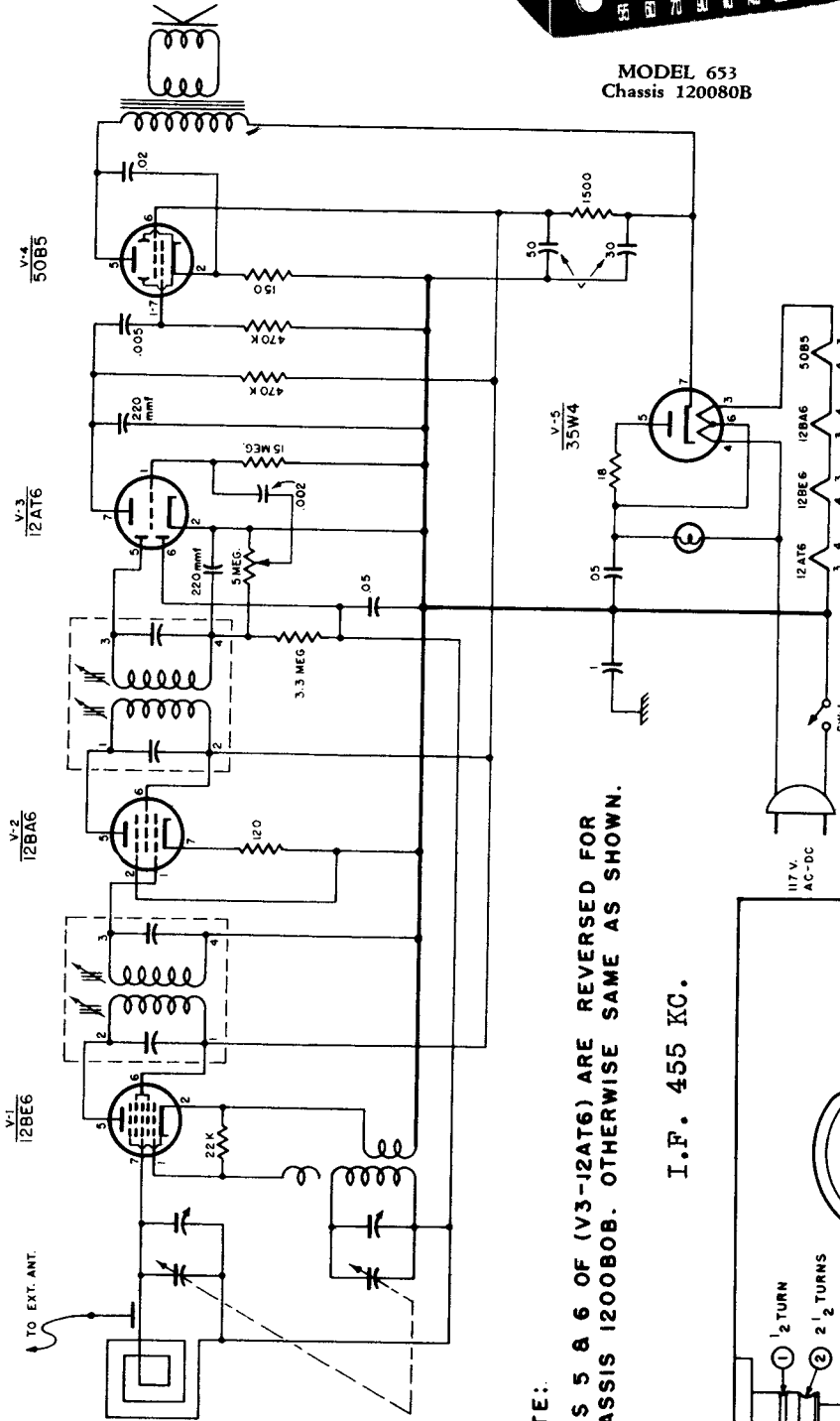

NOTE:

PINS 5 & 6 OF (V3-12AT6) ARE REVERSED FOR CHASSIS 120080B. OTHERWISE SAME AS SHOWN.

I.F. 455 KC.

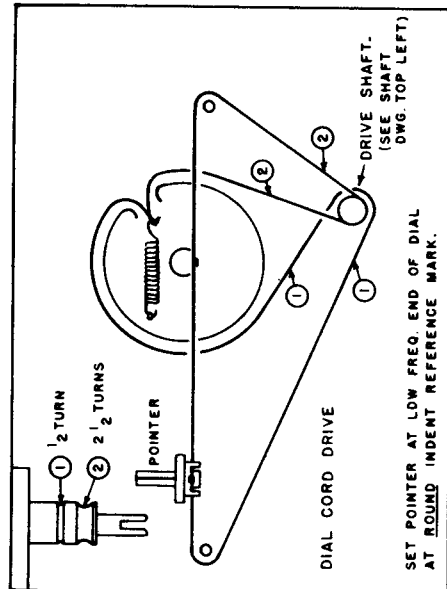

DIAL CORD DRIVE
— FOR CHASSIS 120032B

VOLTAGE READINGS FOR CHASSIS 120032B AND 120080B

Symbol	TUBE	PIN 1	PIN 2	PIN 3	PIN 4	PIN 5	PIN 6	PIN 7
V1	12BE6	-6.2 DC	0	24 AC	11.5 AC	85 DC	85 DC	-0.5 DC
V2	12BA6	0	0	24 AC	37 AC	85 DC	85 DC	1.4 DC
V3	12AT6	0	0	0	11.5 AC	*-0.02 DC	*-0.05 DC	50 DC
V4	50B5	0	5 DC	86 AC	37 AC	115 DC	85 DC	0
V5	35W4	0	0	86 AC	117 AC	110 AC	112 AC	120 DC

*12AT6, Pin 5 is -0.5 in Chassis 120080B

12AT6, Pin 6 is -0.2 in Chassis 120080B

RESISTANCE READINGS FOR CHASSIS 120032B AND 120080B

Symbol	TUBE	PIN 1	Pin 2	Pin 3	PIN 4	PIN 5	PIN 6	PIN 7
V1	12BE6	2400	0.6	25	13	300,000	300,000	3 meg.
V2	12BA6	20	0	25	38	300,000	300,000	120
V3	12AT6	15	0	0	13	*500,000	*3.5	700,000
V4	50B5	400,000	150	75	38	300,000	300,000	400,000
V5	35W4	Inf.	Inf.	75	100	110	95	300,000

*12AT6, Pin 5 is 3.5 in Chassis 120080B

12AT6, Pin 6 is 500,000 in Chassis 120080B

MANUAL OF 1950 MOST-OFTEN-NEEDED RADIO DIAGRAMS

EMERSON RADIO

MODELS: 642

CHASSIS: 120117A

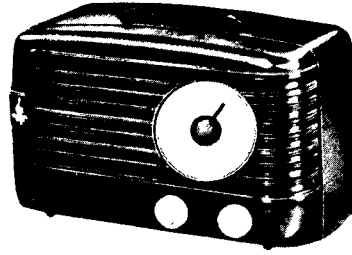

MODEL 642
Chassis 120117A

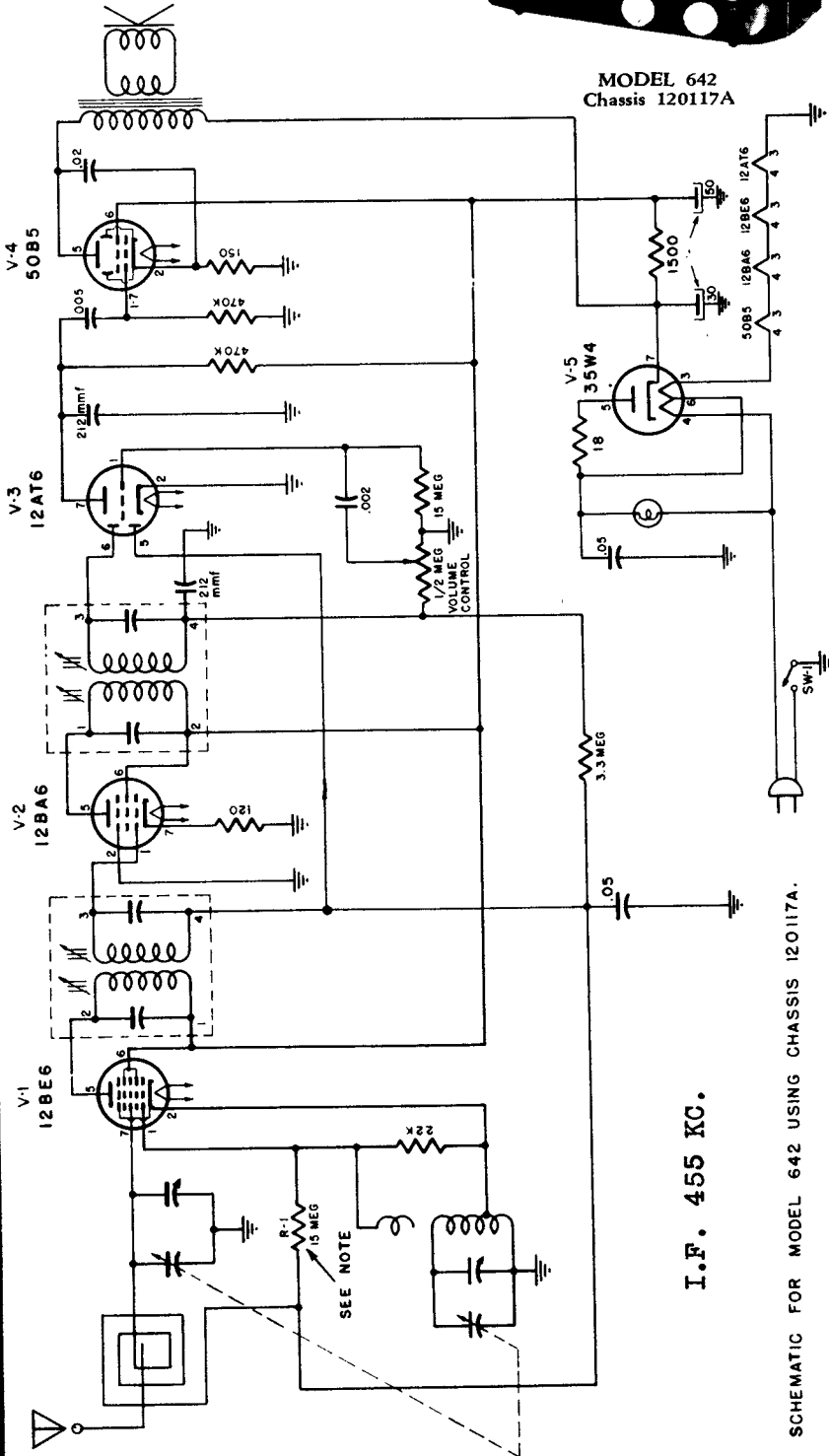
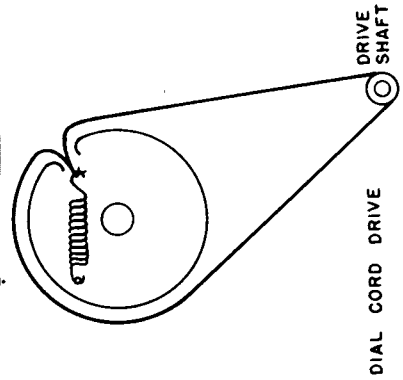

I.F. 455 KC.

SCHEMATIC FOR MODEL 642 USING CHASSIS 120117A.

NOTE: R-1 NOT IN LATER SETS.

VOLTAGE READINGS FOR CHASSIS 120117A

Symbol	TUBE	PIN 1	PIN 2	PIN 3	PIN 4	PIN 5	PIN 6	PIN 7
V1	12BE6	-5.3 DC	0	11.2 AC	25 AC	90 DC	85 DC	-45 DC
V2	12BA6	-45 DC	0	25 AC	38 AC	90 DC	87 DC	1. DC
V3	12AT6	-0.6 DC	0	12 AC	12 AC	-0.45 DC	-0.45 DC	45 DC
V4	50B5	0	5.5 DC	38 AC	85 AC	110 DC	85 DC	0
V5	35W4	0	0	85 AC	117 AC	110 AC	112 DC	120 DC

RESISTANCE READINGS FOR CHASSIS 120117A

Symbol	TUBE	PIN 1	PIN 2	PIN 3	PIN 4	PIN 5	PIN 6	PIN 7
V1	12BE6	2400	0.6	18	32	300,000	300,000	3 meg.
V2	12BA6	3 meg.	0	32	48	300,000	300,000	120
V3	12AT6	15 meg.	0	0	18	3 meg.	500,000	500,000
V4	50B5	400,000	150	48	80	300,000	300,000	400,000
V5	35W4	0	0	80	100	110	100	300,000

MANUAL OF 1950 MOST-OFTEN-NEEDED RADIO DIAGRAMS

EMERSON RADIO

MODEL: 613

CHASSIS MODELS 120085A

Battery Complement: Replace "A" battery with standard "D" flashlight cell. Replace "B" battery with 67½ volt Eveready No. 467 or equivalent.

The color coding of the battery cable is as follows:

Red—B+
White—B—
Yellow—A+
Black—A—

VOLTAGE READINGS

SYMBOL	TUBE TYPE	PIN 1	PIN 2	PIN 3	PIN 4	PIN 5	PIN 6	PIN 7
V1	1R5	1.5	88	60	-3.2	1.5	0	2.8
V2	1U4	2.8	88	88	0	2.8	2.0	4.0
V3	1U5	0	43	18	.4	0	0	1.5
V4	3V4 or 3Q4	4.0	84	0	88	5.3	5.3	6.7

Socket connections are shown as bottom views. Measurements are taken from socket pin to chassis

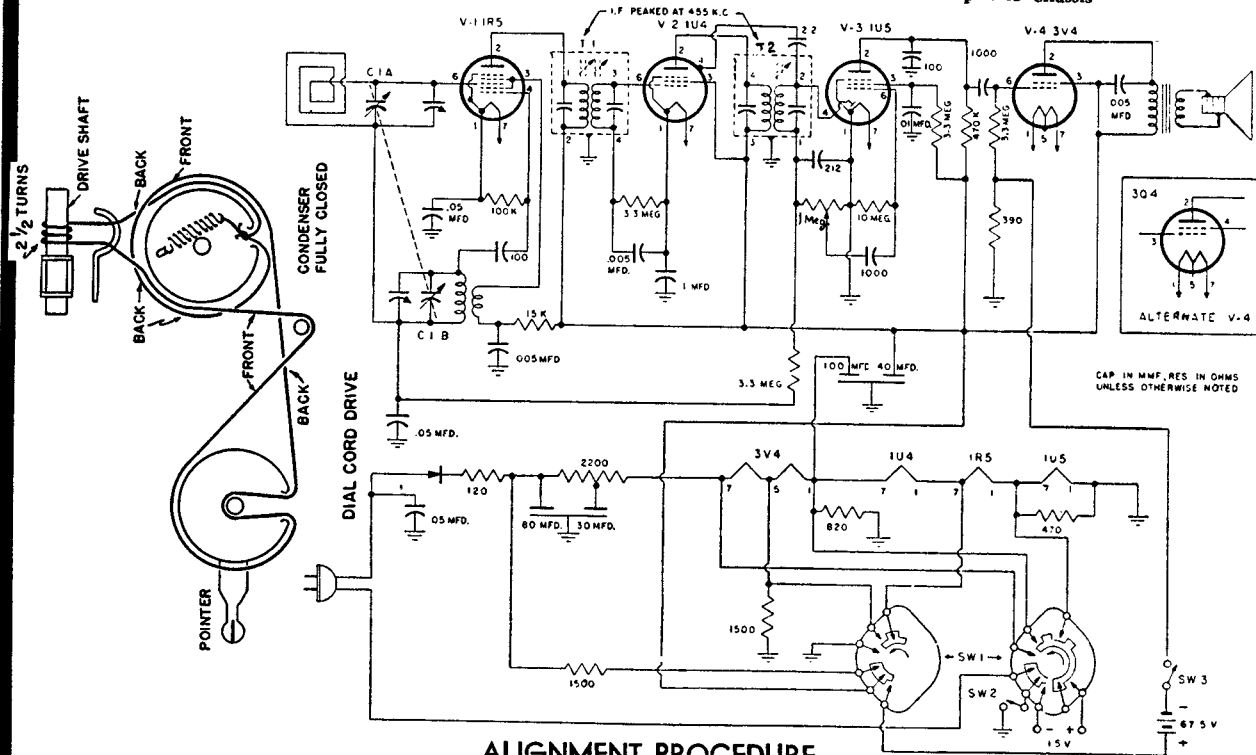

ALIGNMENT PROCEDURE

1. Use battery power when available. When a.c. power is used, connect the line cord through an isolation transformer if available. Otherwise connect a 0.1 mfd. condenser in series with the low side of the signal generator and B—.
2. Set the volume control at maximum. The output of the signal generator should be no higher than that necessary to obtain an output reading. Attenuate the signal input as alignment proceeds. Use an insulated alignment tool.
3. Maintain the loop in the same position relative to the chassis as when the receiver is in the cabinet.
4. Oscillator and antenna trimmers are reached from bottom of chassis.

	DUMMY ANTENNA	SIGNAL GENERATOR COUPLING	SIGNAL GENERATOR FREQUENCY	RADIO DIAL SETTING	OUTPUT METER	ADJUST	REMARKS
1	0.1 mfd.	High side to grid (pin 6) of V1 (1R5). Low side to chassis.	455 KC.	Variable condenser fully open.	Across voice coil.	Primary and secondary of T2 and T1.	Adjust for maximum output. If a.c. is used, without an isolation transformer, reduce dummy antenna to 200 mmf.
2	200 mmf.	High side to external antenna lead. Low side to chassis.	1620 KC.	Variable condenser fully open.	Across voice coil.	Oscillator trimmer on C1B.	Adjust for maximum output.
	200 mmf.	"	1400 KC.	Tune for maximum output.	Across voice coil.	Antenna trimmer on CIA.	Adjust for maximum output.

Emerson Radio

MODEL: 636

CHASSIS MODEL: 120106A

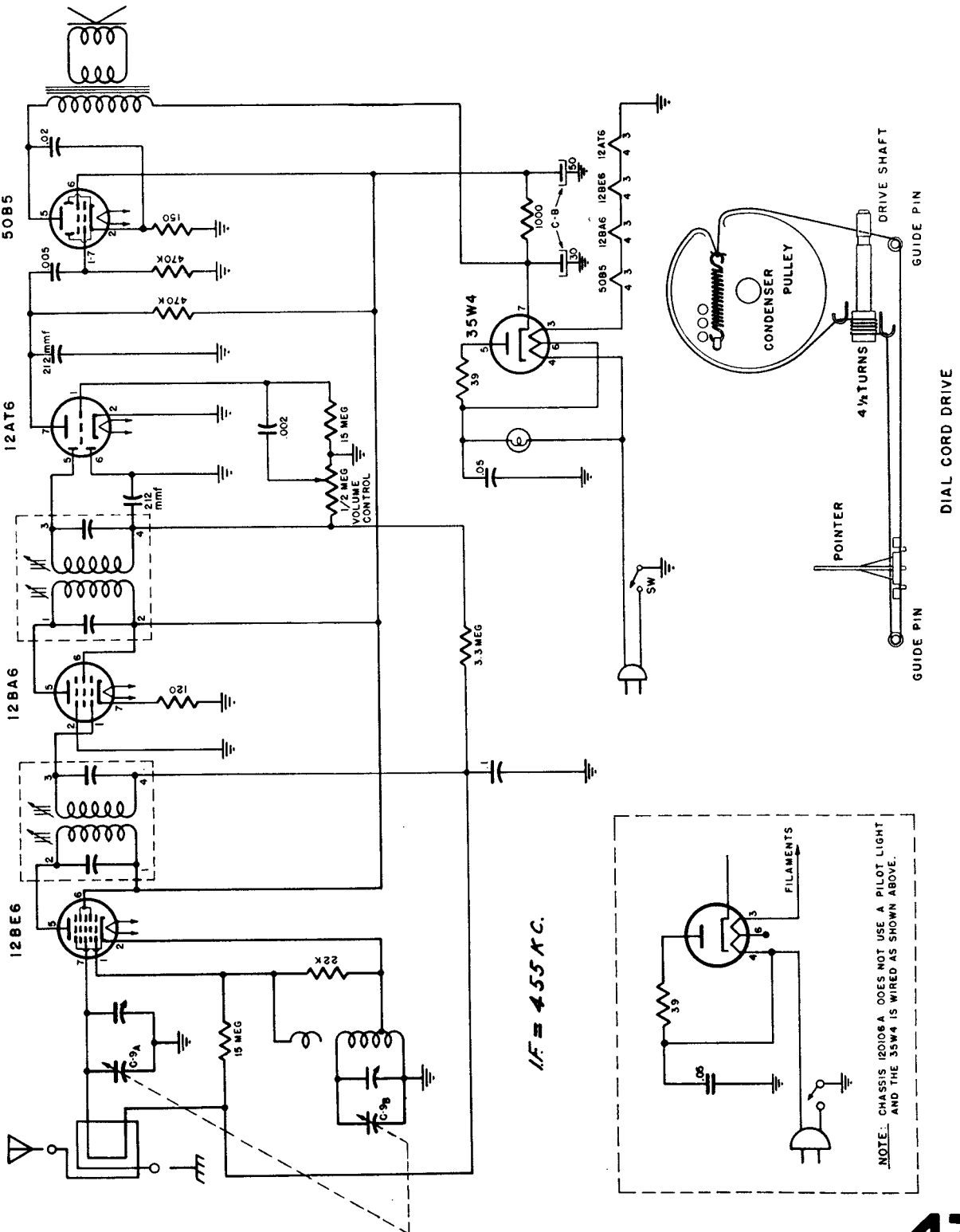

MANUAL OF 1950 MOST-OFTEN-NEEDED RADIO DIAGRAMS

EMERSON RADIO & PHONOGRAPH CORPORATION MODEL: 640

ALIGNMENT INSTRUCTIONS

CHASSIS MODEL: 120112

- To position pointer, turn variable condenser fully closed and set pointer to reference mark at low-frequency end of dial back-plate.
- Volume control should be at maximum; output of signal generator should be no higher than necessary to obtain an output reading.
- Maintain loop in same position relative to chassis, if chassis is removed from cabinet.

	DUMMY ANTENNA	SIGNAL GENERATOR COUPLING	SIGNAL GENERATOR FREQUENCY	RADIO DIAL SETTING	OUTPUT METER	ADJUST	REMARKS
1	.1 mfd.	High side to pin 6 (grid) of 1R5. Low side to chassis.	455 KC.	Tuning condenser fully open.	Across voice coil.	T2 and T1	Adjust for maximum output.
2		Loop	1620 KC.	"	"	C4 (osc. trimmer)	Fashion loop of several turns of wire and radiate signal into loop of receiver. Adjust for maximum output.
3		"	1400 KC.	Tune for maximum output.	"	C3 (Ant. trimmer)	Adjust for maximum output.

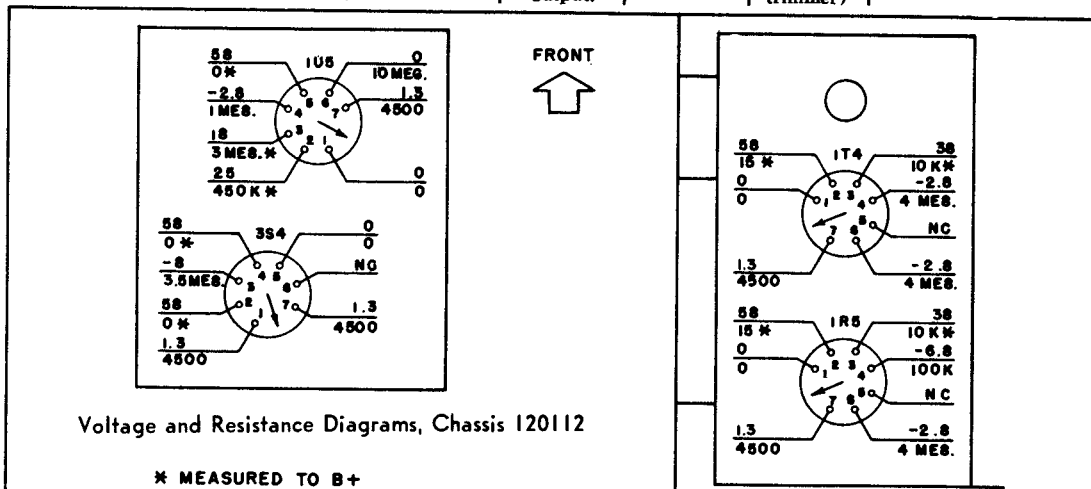

CONDITIONS FOR VOLTAGE AND RESISTANCE READINGS

- Voltages indicated are positive d.c., resistances in ohms, unless otherwise noted.
- Measurements made with voltohmmyst or equivalent.
- Socket connections are shown as bottom views, with measurements from pin to chassis.
- Volume control at maximum, no signal applied, for voltage measurements.
- Nominal tolerance in component values makes possible a variation of $\pm 15\%$ in readings.
- On the diagram, upper valves are voltage, lower valves are resistance; K is Kilohms, MEG is megohms. Resistance marked * are measured to B+.

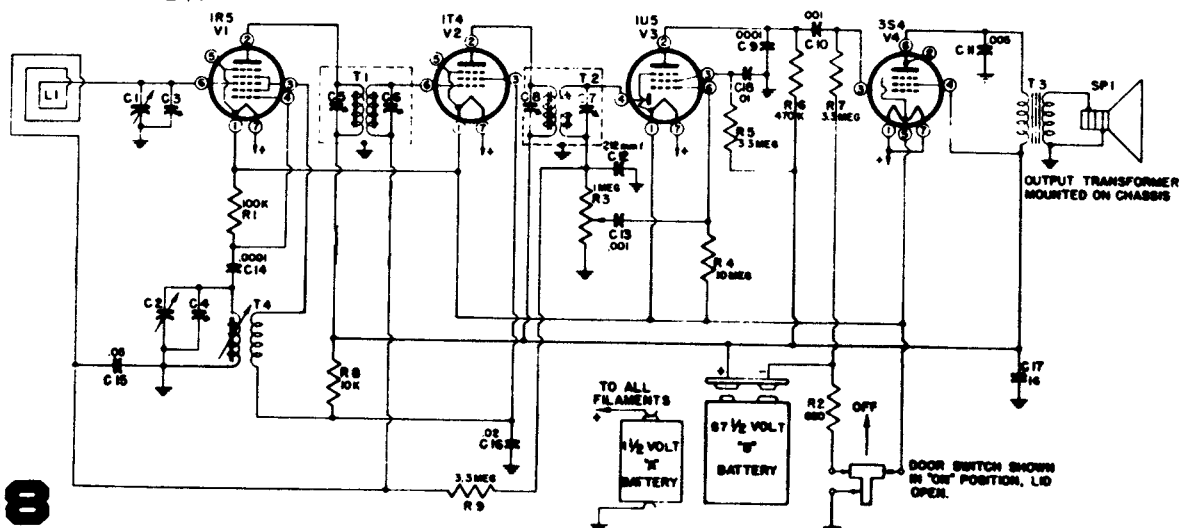

MANUAL OF 1950 MOST-OFTEN-NEEDED RADIO DIAGRAMS

Emerson Radio

MODEL: 645

CHASSIS MODEL: 120115

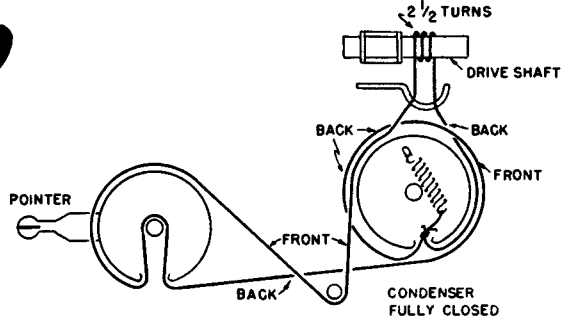
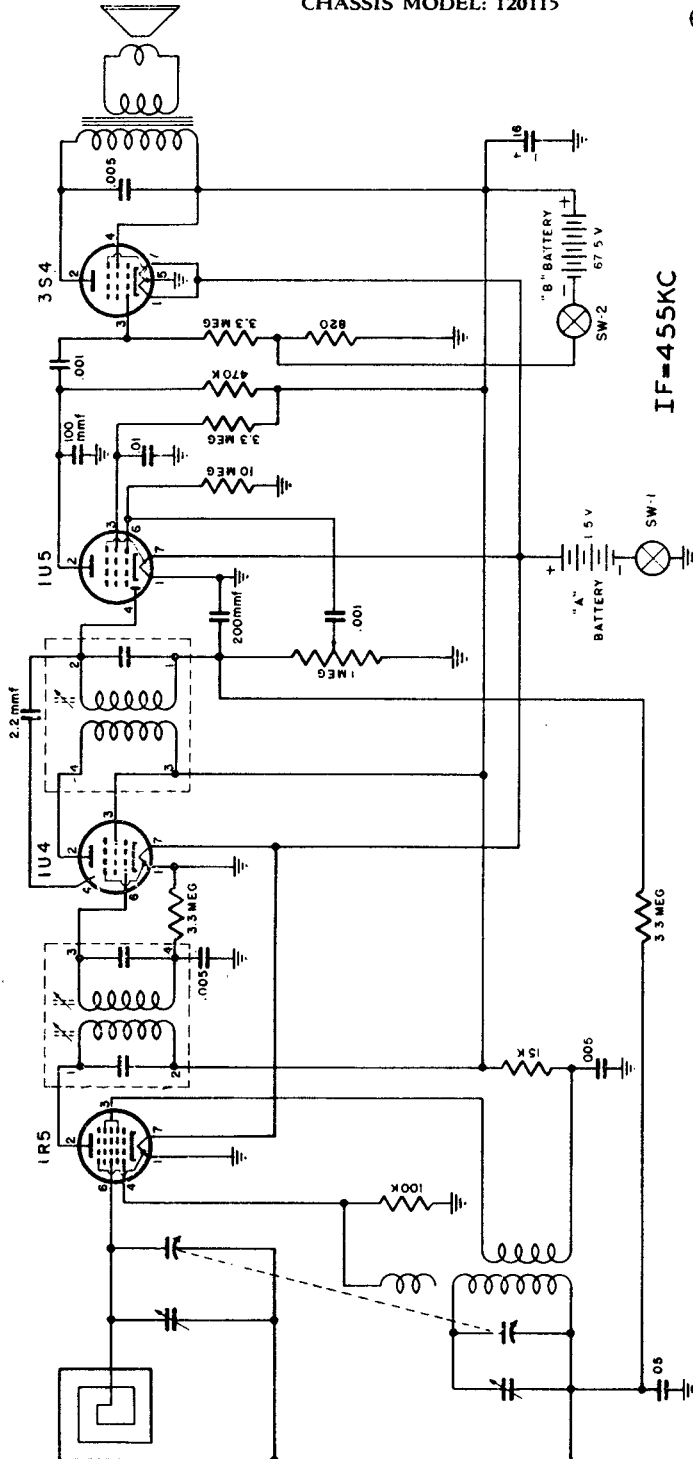

DIAL CORD DRIVE

CONDITIONS FOR VOLTAGE AND RESISTANCE READINGS

1. Voltage readings are + dc. volts, resistance readings are ohms unless otherwise noted.
2. All measurements made with voltohmmyst or equivalent.
3. Socket connections are shown as bottom views, with valves measured from socket pin to chassis.
4. No signal applied for voltage measurements.
5. Nominal tolerance on component values makes possible a variation of $\pm 15\%$ in readings.
6. On the voltage and resistance diagram, readings above line are voltage, valves below line indicate resistance. K = kilohms, MEG = megohms.
7. Valves marked * measured to pin 4 of V-4 (B+).

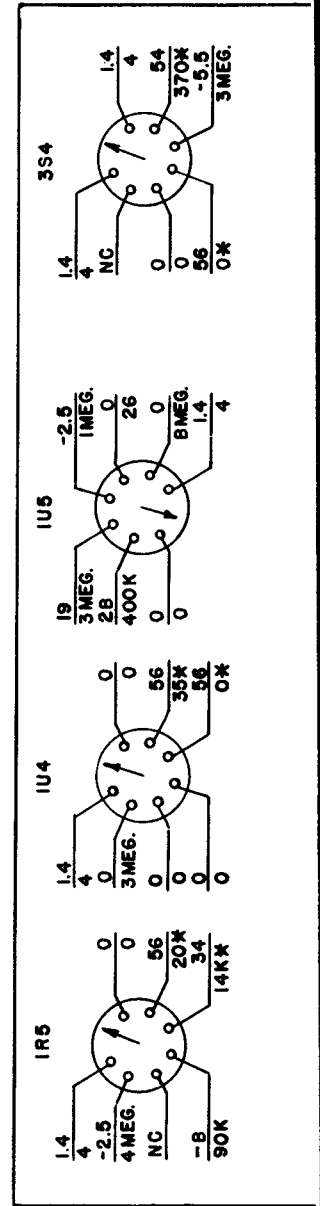

MANUAL OF 1950 MOST-OFTEN-NEEDED RADIO DIAGRAMS

Emerson Radio

SERVICE NOTES

MODEL: 656B, 657B

CHASSIS MODELS: 120122B

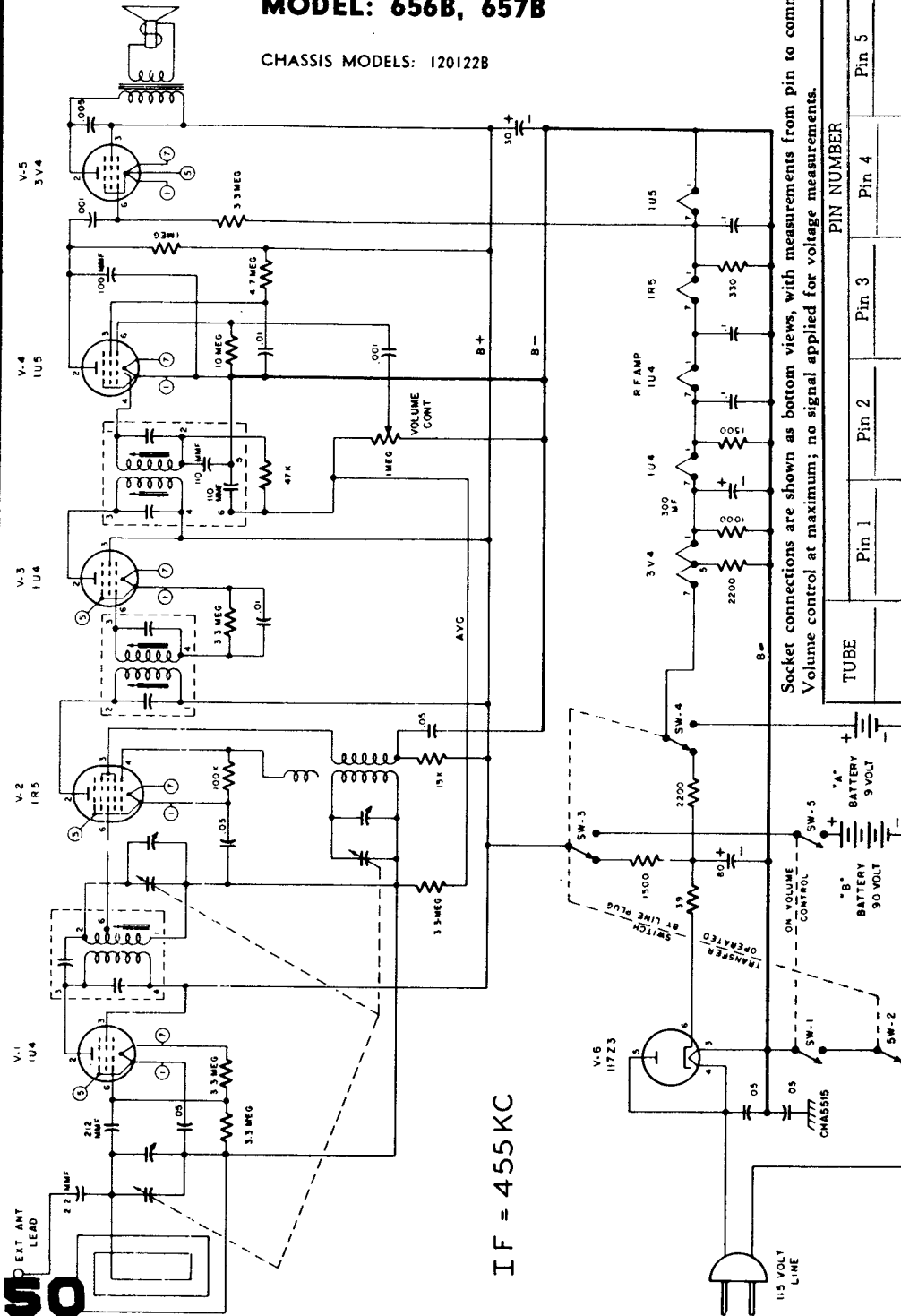

IF = 455 KC

Socket connections are shown as bottom views, with measurements from pin to common negative. Volume control at maximum; no signal applied for voltage measurements.

TUBE	PIN NUMBER						
	Pin 1	Pin 2	Pin 3	Pin 4	Pin 5	Pin 6	Pin 7
1U4	2.8 d.c.	92 d.c.	92 d.c.	N.C.	2.8 d.c.	1.8 d.c.	4.2 d.c.
1R5	1.4 d.c.	92 d.c.	60 d.c.	-10 d.c.	1.4 d.c.	2 d.c.	2.8 d.c.
1U4	4.2 d.c.	92 d.c.	92 d.c.	N.C.	4.2 d.c.	3.1 d.c.	5.8 d.c.
1U5	0	26 d.c.	21 d.c.	-5V d.c.	-5V d.c.	0	1.4V d.c.
3V4	5.7 d.c.	88 d.c.	92 d.c.	0	7 d.c.	1.2 d.c.	8.5 d.c.
117Z3	N.C.	120 d.c.	0	120 a.c.	120 a.c.	120 d.c.	0

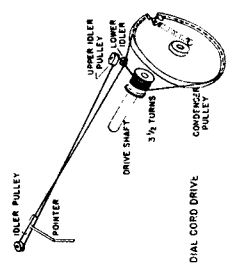

MANUAL OF 1950 MOST-OFTEN-NEEDED RADIO DIAGRAMS

THE FIRESTONE TIRE & RUBBER CO.

Stock No. 4-B-31
Code No. 332-8-139143

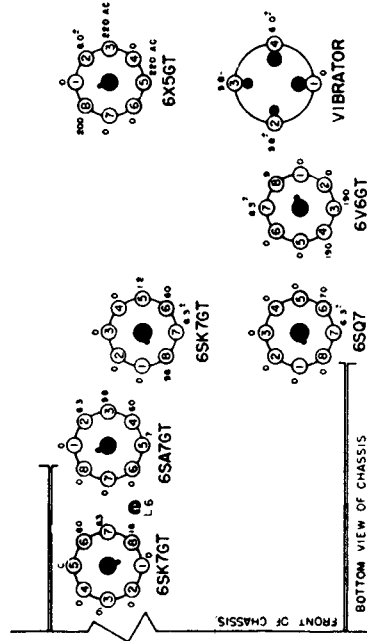
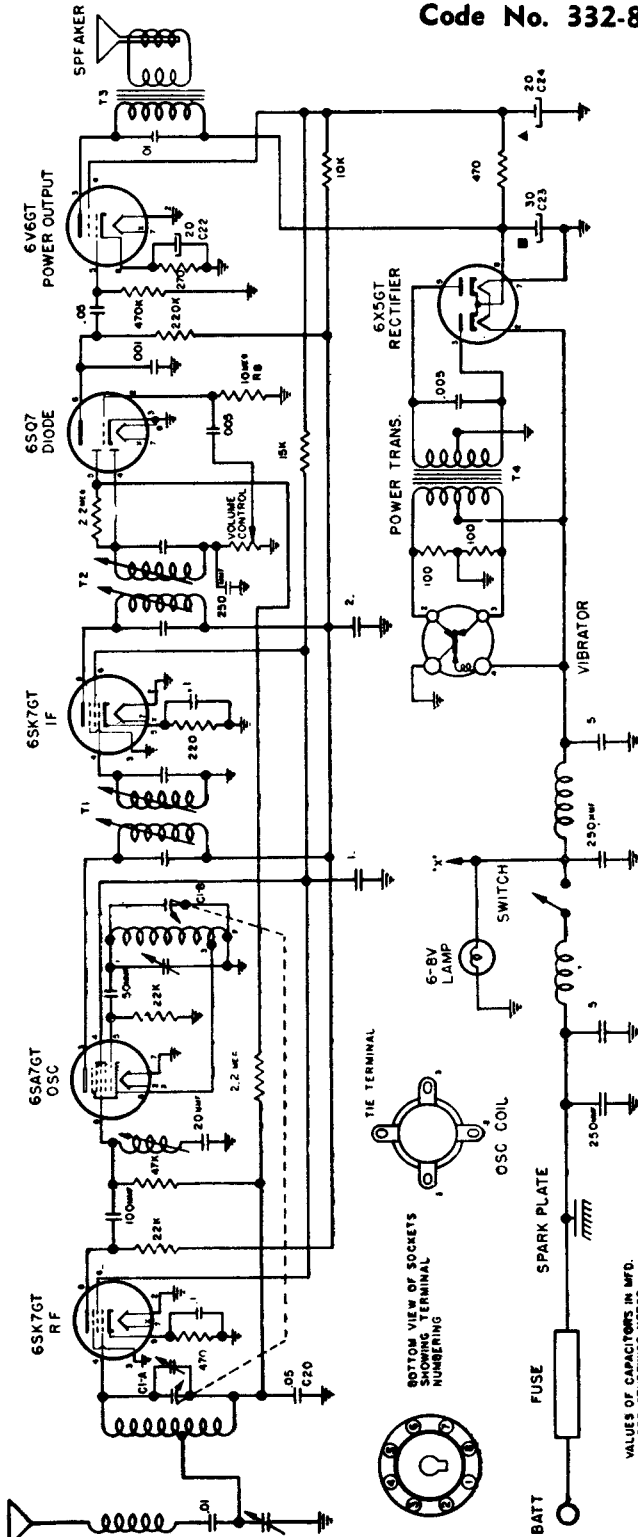

Socket Voltages

Voltages taken from the different points of the circuit to the chassis are measured with volume control in maximum position, all tubes in their sockets, no signal applied, and with a volt meter having a resistance of 20,000 ohms per volt. These voltages are clearly shown on the voltage chart.

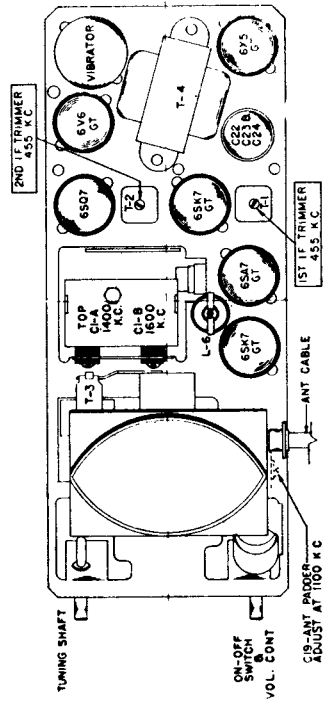

Tube and Trimmer Locations

The bottom cover (the one with the speaker louvers) can be removed to permit servicing of major components, such as tubes and vibrator, by removing the eight (8) screws holding it to the top cover. There are three (3) screws on each side, one (1) in the rear, and one (1) in the front.

MANUAL OF 1950 MOST-OFTEN-NEEDED RADIO DIAGRAMS

Gamble-Skogmo, Coronado Radio Model 05RA1-43-7755A

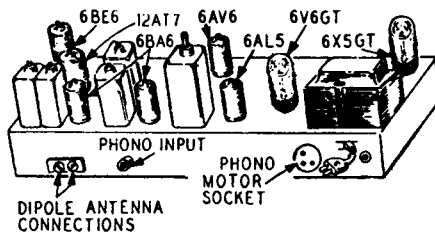
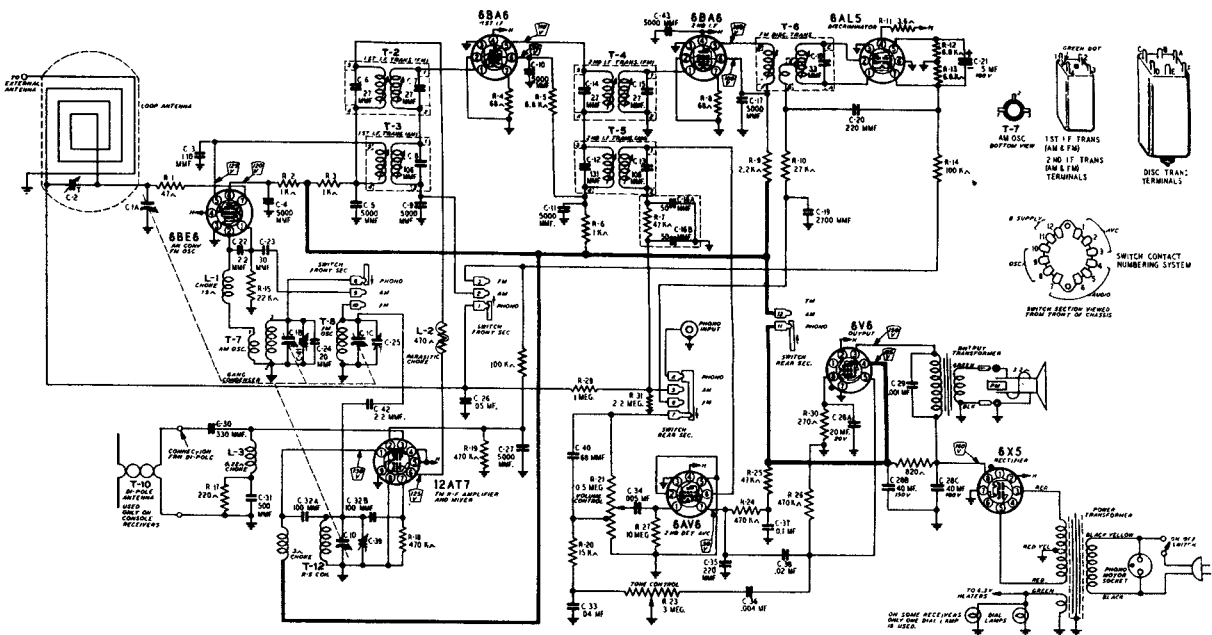

Frequency Ranges —
 Broadcast 540-1600 KC
 Frequency modulation 88-108 MC
 Intermediate Frequency —
 AM 455 KC — FM 10.7 MC

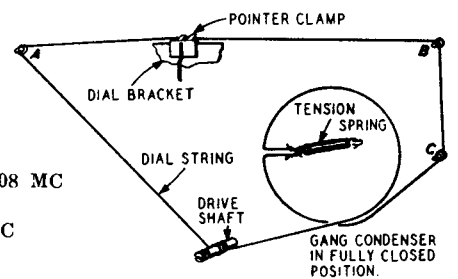

Gamble-Skogmo, Coronado Radio Models 94RA1-43-8510B, & -8511B

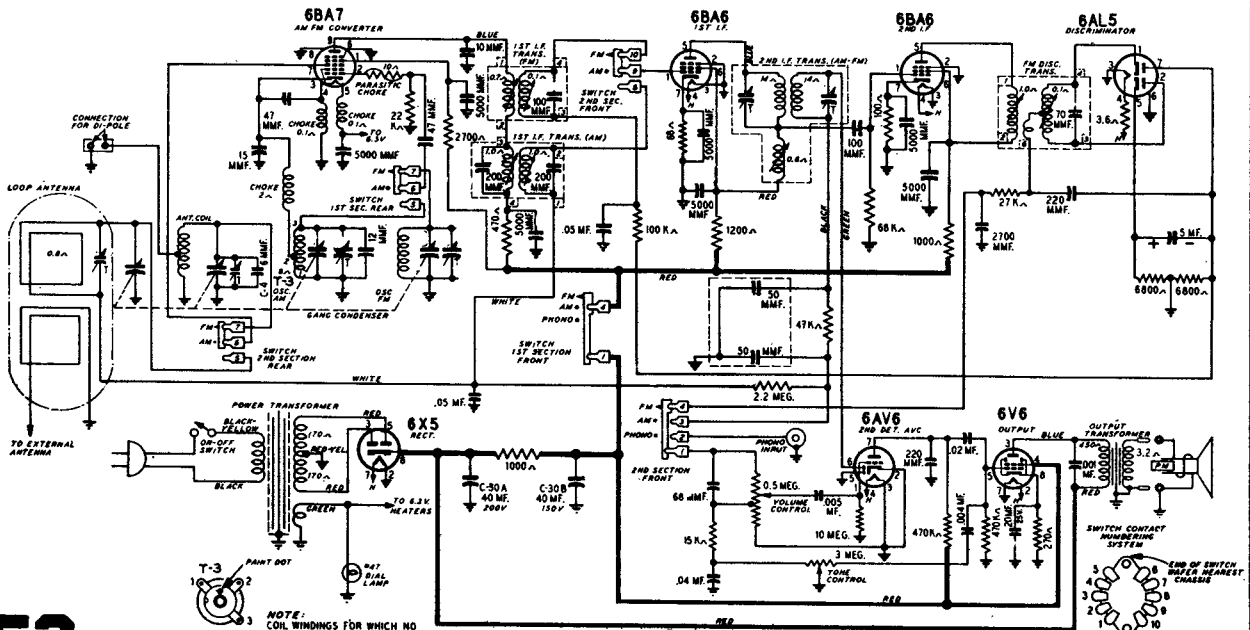

NOTE: COIL WINDINGS FOR WHICH NO RESISTANCES ARE SHOWN HAVE A D.C. RESISTANCE OF LESS THAN 0.1.

Intermediate Frequency —
 AM 455 KC — FM 10.7 MC

MANUAL OF 1950 MOST-OFTEN-NEEDED RADIO DIAGRAMS

GENERAL ELECTRIC

MODEL 4SJ4A1



Model
4SJ4A1
Playtalk

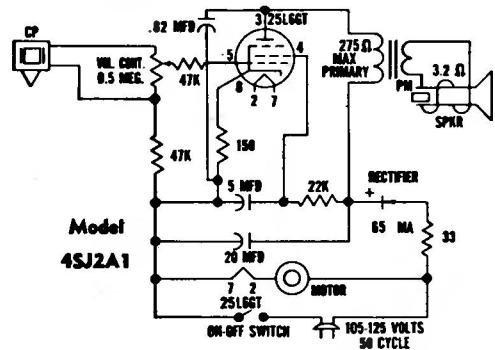
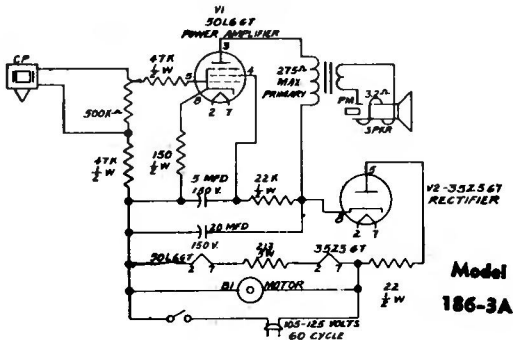
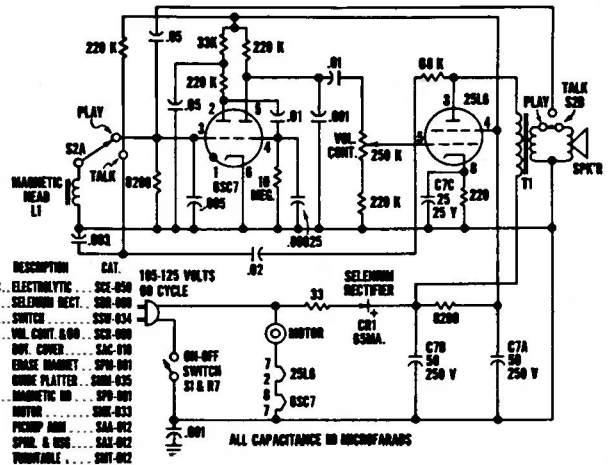

MODEL 4SJ3A1 TOY RADIO-PHONOGRAPH SOCKET VOLTAGE DATA

12SA7	12SQ7	50L6GT	35Z5GT
Pin	Pin	Pin	Pin
1 Gnd	1 Gnd	1 0	1
2 24VAC	2 0	2 24VAC	2 80VAC
3 95V	3 Gnd	3 115V	3 90VAC
4 95V	4 0	4 95V	4
5 6 1/2 V	5 0	5 0	5 110VAC
6 0	6 35V	6	6
7 12VAC	7 0	7 75VAC	7 110VAC
8 0	8 12VAC	8 5V	8 120V

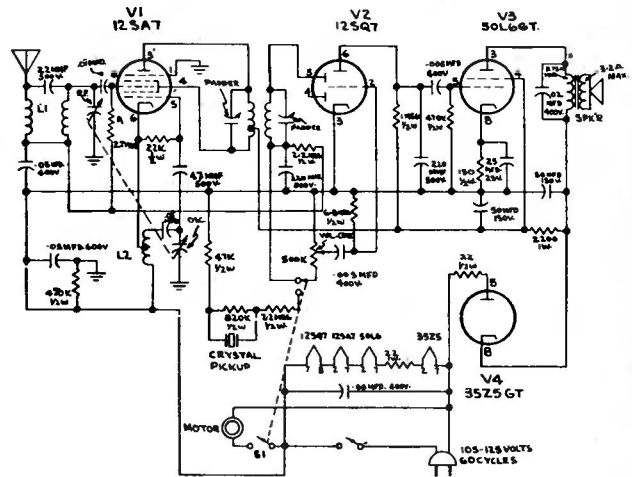

ALIGNMENT INSTRUCTIONS

1. Turn S1 to Radio and volume to maximum. Connect an output meter across the speaker voice coil. Connect generator ground to B- through a .1 mfd. condenser, and the high side to pin 8 of the 12SA7 tube through .03 mfd. Tune generator to 445 kc. and tune T1 trimmers for maximum output reading.
2. Remove generator connection to pin 8, unsolder antenna and attach generator to L1 through 25 mmfd. Turn tuning condenser of set fully open. Set generator to 1620 kc. Tune oscillator trimmer on tuning gang for maximum reading; set R.F. trimmer for maximum output reading. Use only enough generator output to get a reading on the output meter.

MANUAL OF MOST-OFTEN-NEEDED RADIO DIAGRAMS

GENERAL ELECTRIC

MODELS 129, 131

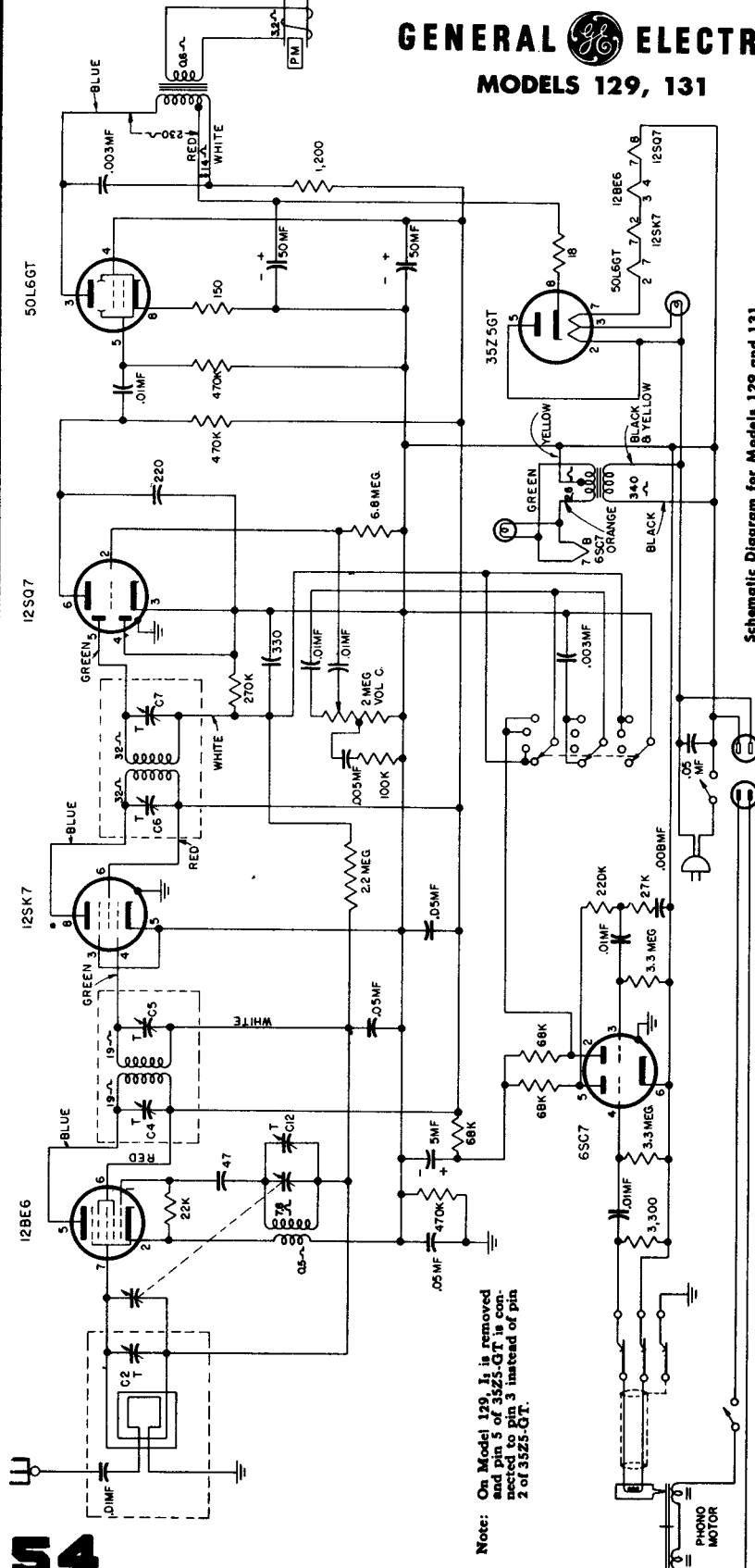

Schematic Diagram for Models 129 and 131

ALIGNMENT CHART

Step	Connect Test-Oscillator To:	Test Oscillator Setting	Dial Setting	Adjust Trimmers For Max. Output
1	12SK7 grid (Pin 4) in series with .05 mf.	455 kc	—	C6 and C7
2	12BE6 grid (Pin 7) in series with .05 mf.	455 kc	—	C4 and C5 Readjust C6 and C7
3	Blue wire on loop in series with 200 mmf. and 470 ohms.	1500 kc	1500 kc	C12 (Osc.); C2 (Ant.)

* Rock gang condenser when making alignment.

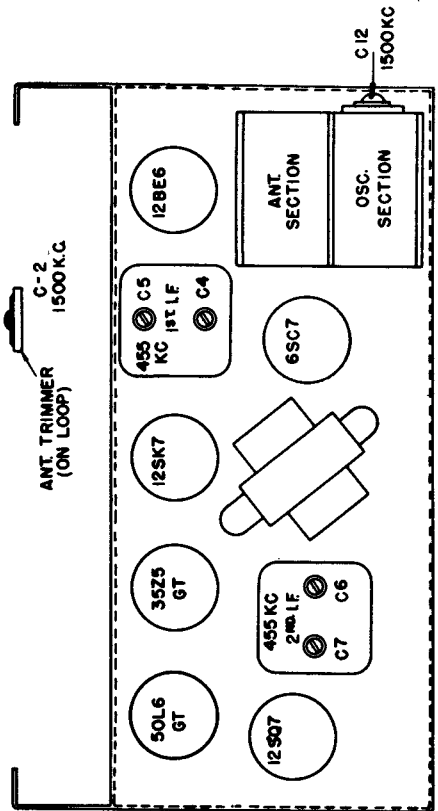

MANUAL OF 1950 MOST-OFTEN-NEEDED RADIO DIAGRAMS

GENERAL ELECTRIC MODELS 135 & 136

Models 123, 124, and 125, have a similar circuit to the one shown, but use a 50C5 instead of a 50L6GT, and a 35W4 instead of a 35Z5GT rectifier.

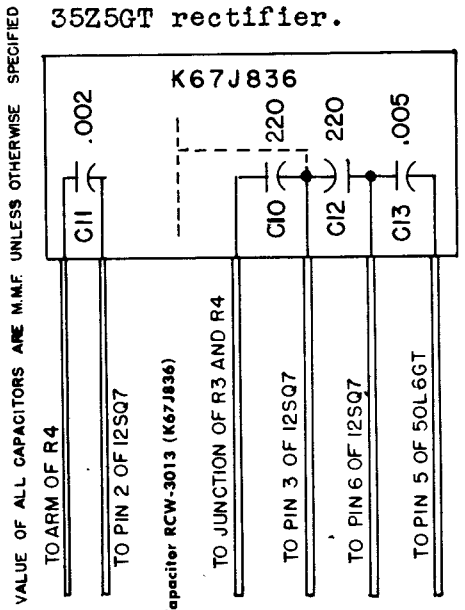
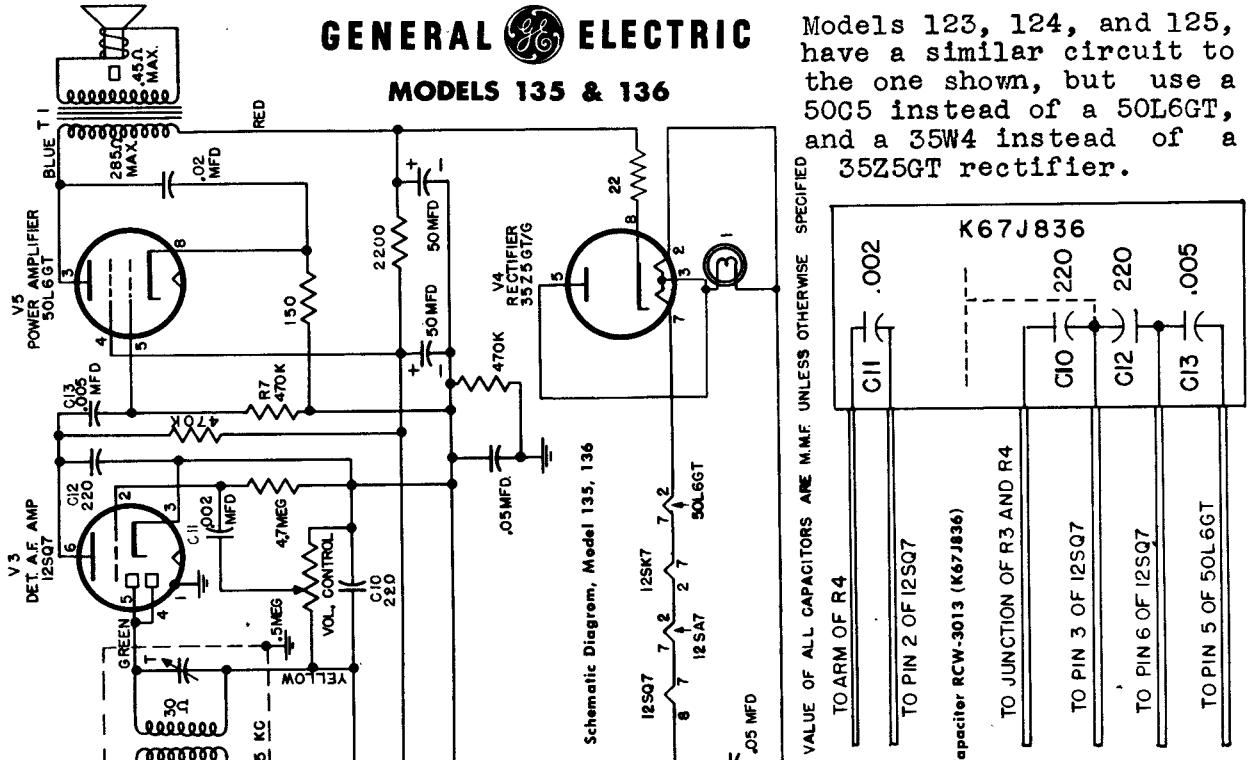
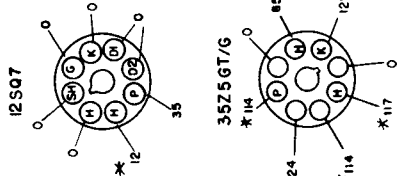

Fig. 2.

FRONT OF CHASSIS

LATE PRODUCTION CHANGES. Type 12BA6 used instead of 12SK7; note that pin connections differ. This new tube uses 47 ohm resistor from cathode to B-. R7 was changed to 1 megohm. T1 audio supplied with tapped primary.



VOLTAGES MEASURED BETWEEN SOCKET TERMINALS AND B- WITH 20,000 OHM PER VOLT METER.
VOLUME CONTROL MINIMUM
* INDICATES AC VOLTS

BOTTOM VIEW OF CHASSIS

CAPACITORS C10, 11, 12, AND C13

Some production receivers use a four-section ceramic unit incorporating capacitors C10, 11, 12 and C13. The ceramic unit, RCW-3013, is illustrated in Fig. 2 for lead identification to capacitor sections and chassis circuit wiring. Other receivers may be found to have individual component capacitors in place of the four-section ceramic unit.

MANUAL OF 1950 MOST-OFTEN-NEEDED RADIO DIAGRAMS

GENERAL ELECTRIC

ALIGNMENT CHART

MODEL 145

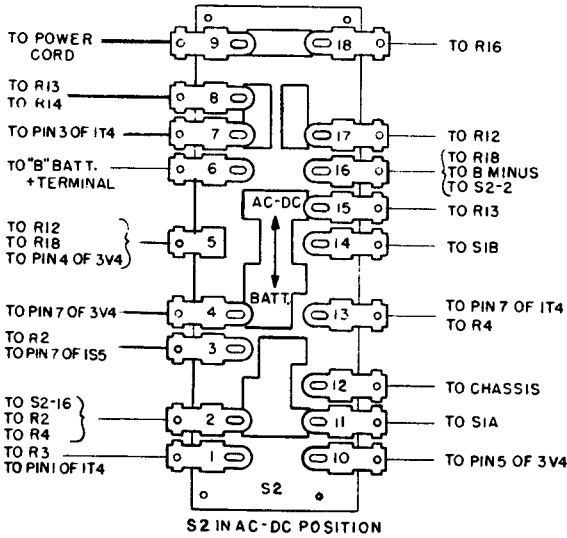

Switch Connections

Step	Connect Test Oscillator To:	Test Oscillator Setting	Dial Setting	Adjust for Maximum Output
1	1T4 grid (Pin 6) in series with .05 mfd. cap.	455 KC	550 KC	2nd i-f transformer (T2) primary and secondary cores.
2	1R5 grid (Pin 6) in series with .05 mfd. cap.	455 KC	550 KC	1st i-f transformer (T1) primary and secondary cores.
3	Inductively coupled (see Note 4)	1620 KC	Gang condenser completely open.	C2B for maximum.
4	Inductively coupled (see Note 4)	1500 KC	For max. signal. Set dial pointer at 1500 KC mark on dial scale.	C1B for maximum.

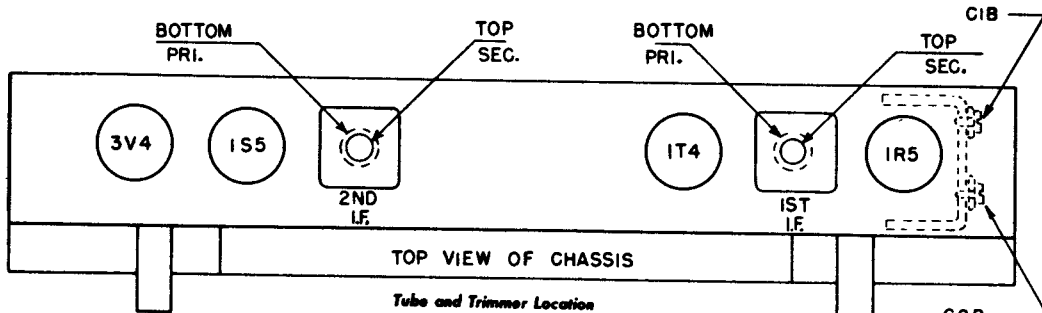
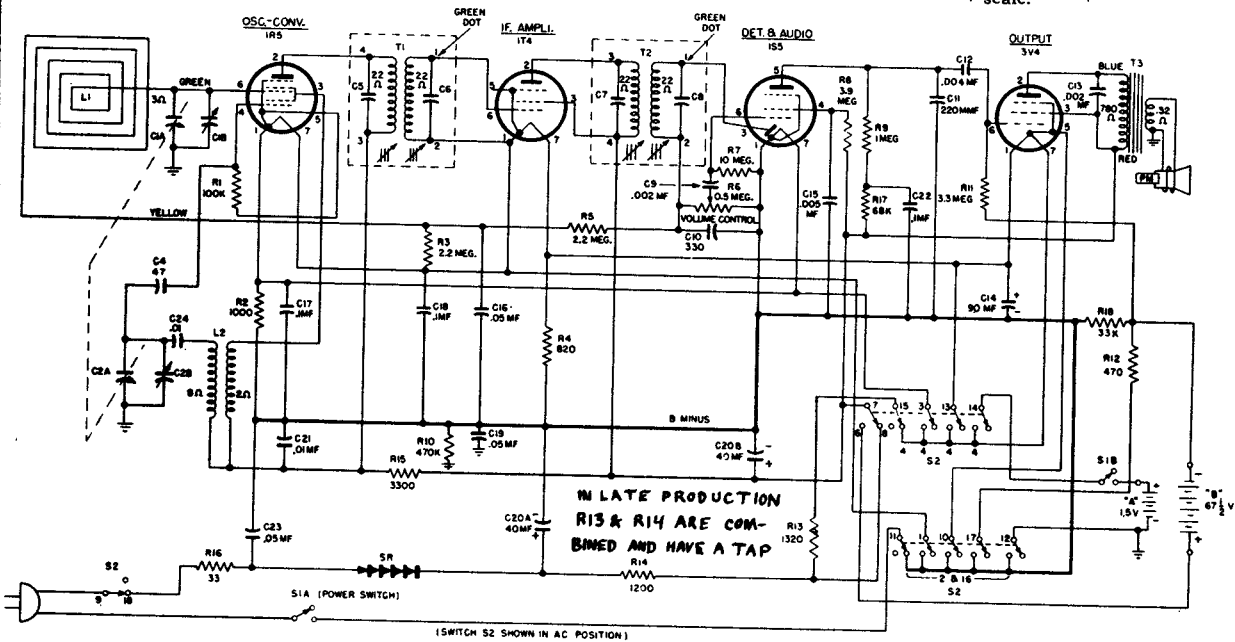

TOP VIEW OF CHASSIS

Tube and Trimmer Location

MANUAL OF 1950 MOST-OFTEN-NEEDED RADIO DIAGRAMS

GENERAL ELECTRIC

RADIO

MODEL 165 MODEL 650

BATTERY—AC OR DC OPERATION.

The left knob turns on the battery, provided that the power plug is well inserted into the socket in the chassis.

For a-c or d-c supply (105–115 volts, 50 to 60 cycle operation), the same knob switches on the power when the power plug is pulled out of its socket in the chassis and inserted into the house outlet.

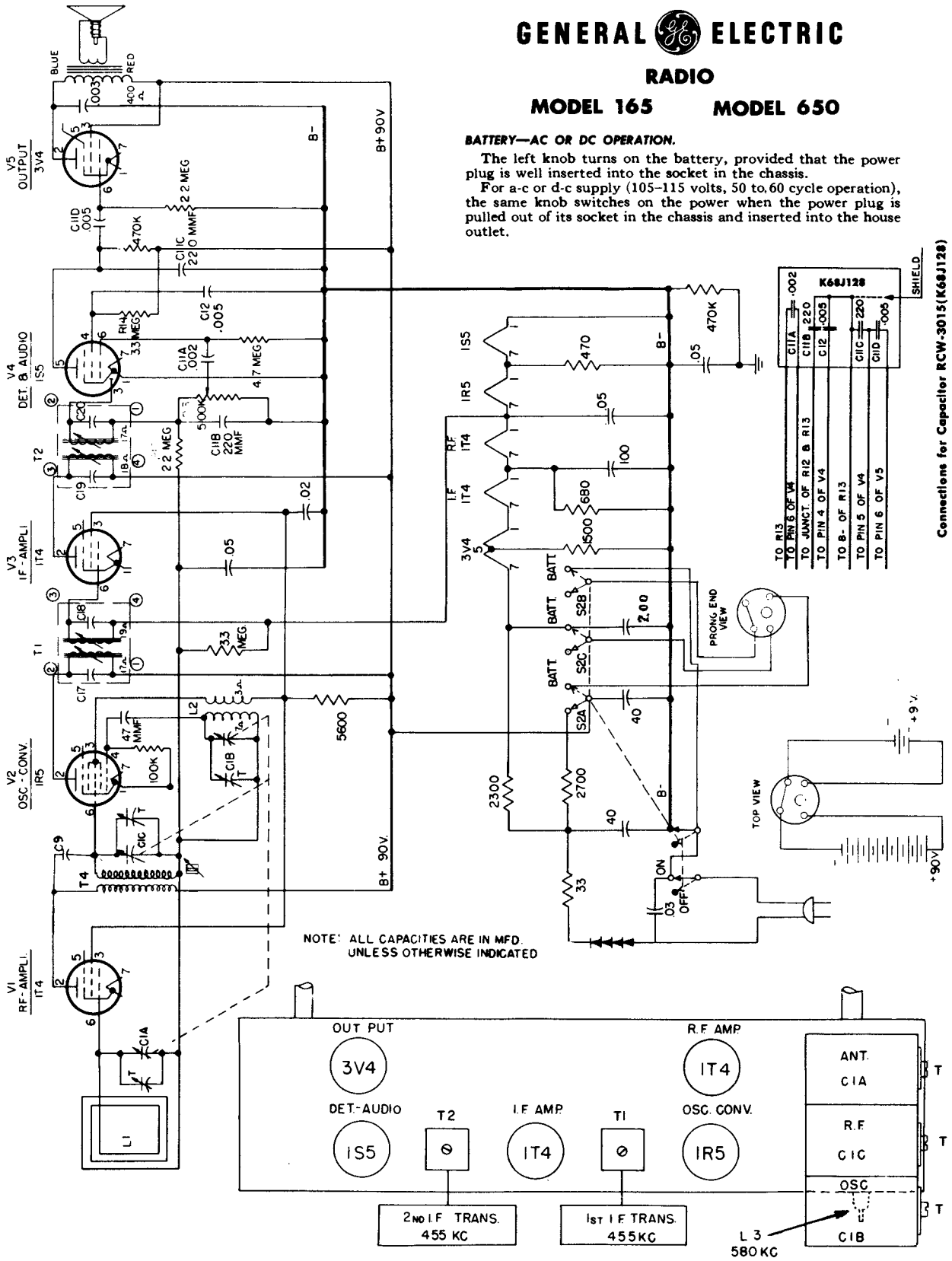

Connections for Capacitor RCW-3015(K68J128)

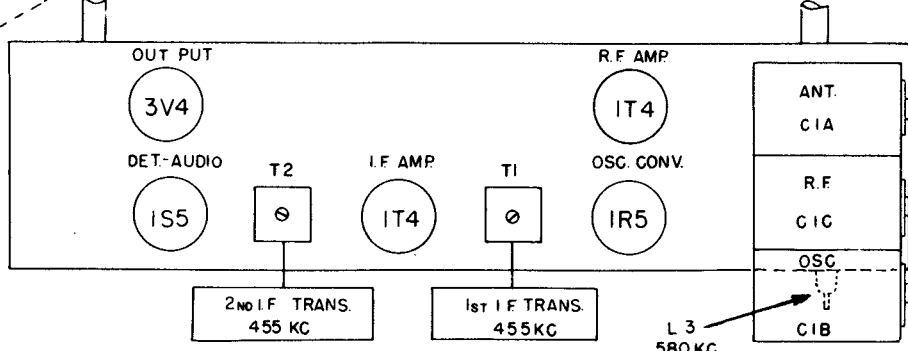

Tube and Trimmer Location (Model 165)

MANUAL OF 1950 MOST-OFTEN-NEEDED RADIO DIAGRAMS

GENERAL ELECTRIC

MODEL 218

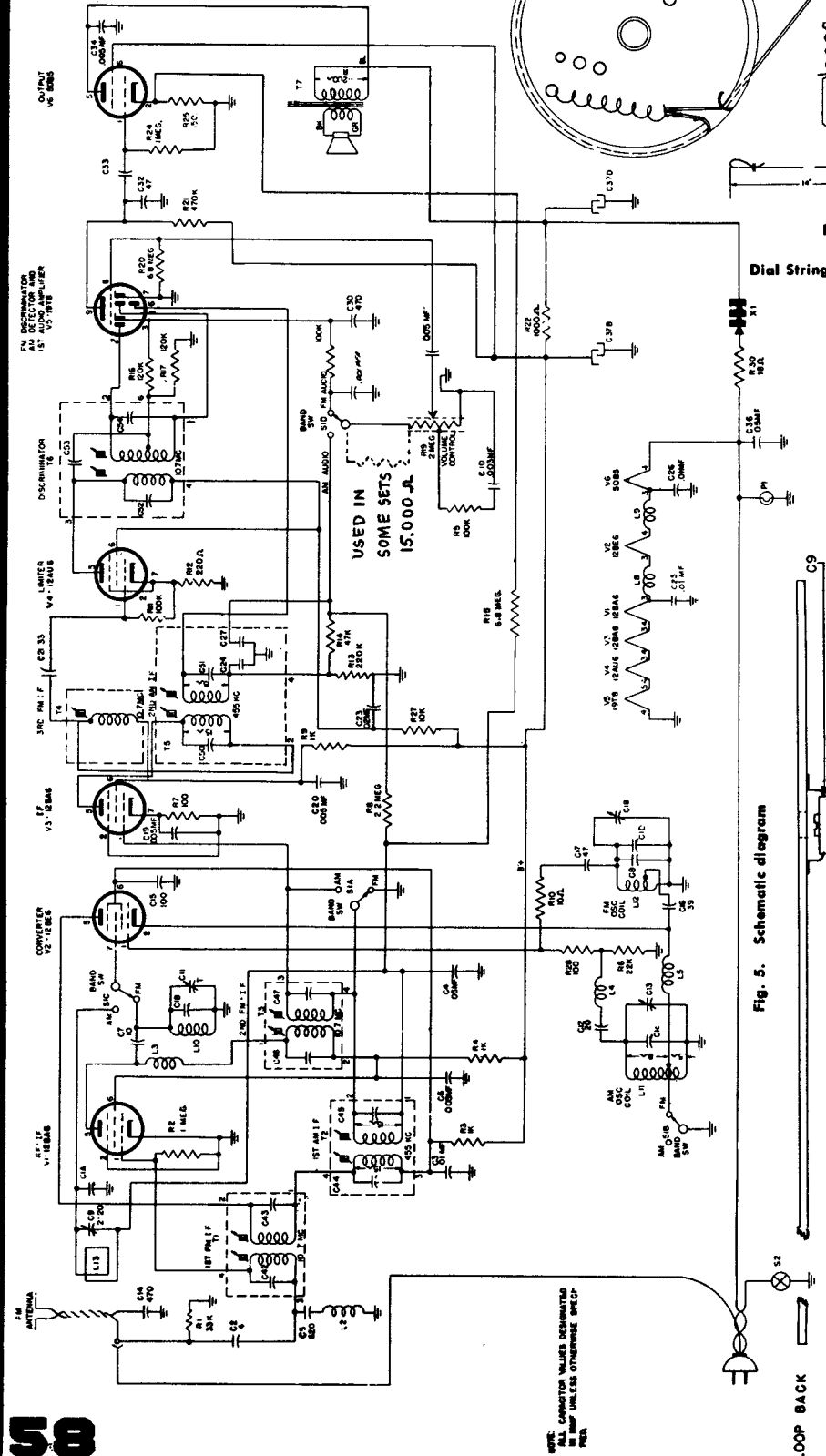

Fig. 5. Schematic diagram

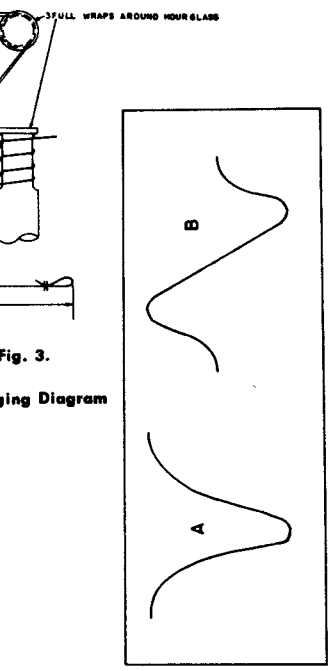

Fig. 3. Dial Stringing Diagram

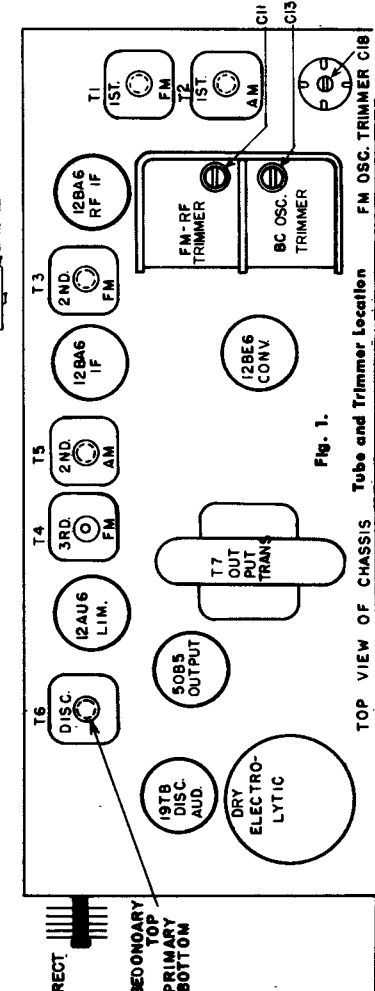

Fig. 1.

TOP VIEW OF CHASSIS Tube and Trimmer Location

Fig. 2. I-F and Discriminator Curves

MANUAL OF 1950 MOST-OFTEN-NEEDED RADIO DIAGRAMS

GENERAL ELECTRIC

MODEL 218

ALIGNMENT

EQUIPMENT NECESSARY FOR METER ALIGNMENT

1. Signal generator G-E YGS-3, or equivalent.
2. 20,000 ohm-per-volt meter.
3. Output meter.
4. .01 mfd. capacitor.
5. Four-turn, six-inch diameter loop of bell wire for AM, r-f and oscillator alignment.
6. Isolation transformer.

NOTES FOR METER ALIGNMENT

1. Connect a 20,000 ohm-per-volt meter from junction of C29 and R18 to chassis. Use a ten-volt scale for steps 3, 4 and 5.
2. Connect a 20,000 ohm-per-volt meter from the grid of the limiter (pin 1 of V4) to cathode of limiter (pins 2 or 7 of V4) in series with a 200,000-ohm resistor. The resistor must be connected directly to the grid pin to minimize capacity loading and to isolate the i-f signal voltage from the meter. Keep signal generator down so that the meter does not indicate more than one volt at the grid (5 microamps through 200,000 ohms).

3. Connect a standard output meter across the speaker voice coil. Turn volume control full on. Keep signal generator output low so that output meter indicates not more than 1/2 watt during alignment.

4. Align the AM oscillator trimmer (C13) and the AM r-f trimmer (C9) by coupling the signal to the loop antenna inductively. Connect a four-turn, six-inch diameter loop of bell wire across the signal generator output terminals, and locate the loop about one foot from the radio loop antenna. The position of the loop in respect to the radio loop antenna should not be changed during any one set of adjustments to prevent possible errors in the peak readings.

5. Disconnect the copper strap from the band switch to pin 7 of the 12BE6 to align the 1st FM i-f transformer. Unsolder the strap from the tube pin connection. Resolder the strap after T1 is aligned to 10.7 mc as in step 8.

6. The AM r-f alignment should be made before the FM r-f alignment. With the gang condenser fully closed, the pointer should point to the dot on the dial scale after the letters "FM" on the left end of the dial scale.

7. The termination impedance of the signal generator should be 300 ohms for FM r-f alignment.

MODEL 218 "H" VERSION

It is the same as the Model 218 except that the local oscillator is designed to operate on the high side of the incoming signal on FM reception. This change reduces the possibility of local oscillator radiation interfering with television reception.

METER ALIGNMENT CHART

Step	Signal Generator Frequency	Signal Input Point	Band Switch Setting	Dial Setting	Adjust	See Note
AM I-F ALIGNMENT						
1	455 kc modulated with 400 cps	12BE6 grid (pin 7 of V2) thru .01 mfd.	AM	550 kc	Secondary and primary slugs of T5 for maximum.	3
2					Secondary and primary slugs of T2 for maximum.	
FM DISCRIMINATOR AND I-F ALIGNMENT						
3	10.7 unmodulated	12BA6 grid (pin 1 of V3) thru 0.1 mfd.	FM		Adjust T6 secondary for zero. Apply 1 volt signal input.	1
4					Detune signal generator to point of maximum meter reading.	
5	Same freq. as in step 4	Adjust T6 primary for maximum meter reading.				
6	10.7 mc unmodulated	12BA6 grid (pin 1 of V1) thru .01 mfd.			Adjust slug of T4 for maximum.	2
7					Adjust secondary and primary slugs of T3 for maximum.	
8		12BE6 grid (pin 7 of V2) thru .01 mfd. and 4700 ohms. See note 5.			Adjust secondary and primary slugs of T1 for maximum.	2, 5
AM R-F ALIGNMENT						
9	1500 kc AM modulated with 400 cps	Inductively coupled. See note 4.	AM	1500 kc	Adjust C13 for maximum.	3, 4, 6.
10					Adjust C9 for maximum while rocking dial.	
FM R-F ALIGNMENT						
11	108 mc unmodulated	Dipole terminals	FM	108 mc	Adjust C18 for maximum.	2, 6, 7.
12	98 mc unmodulated			For max. output	Adjust C11 for maximum while rocking dial.	

MANUAL OF 1950 MOST-OFTEN-NEEDED RADIO DIAGRAMS

GENERAL  ELECTRIC

RADIO MODEL 226

To align the oscillator and r-f trimmers, the signal generator output is inductively coupled to the radio loop, L1, by connecting a four-turn, six-inch diameter loop of bell wire across its output terminals and then locating the loop about one foot from the radio loop antenna. To prevent possible errors in comparative peak readings, the position of signal generator loop with respect to the radio loop antenna should not be changed during measurement.

The output meter is connected across the terminals of the loudspeaker voice coil.

The receiver volume control should be turned to maximum and test oscillator signal output attenuated during alignment to develop not more than 1.4 volts output meter reading at the loudspeaker.

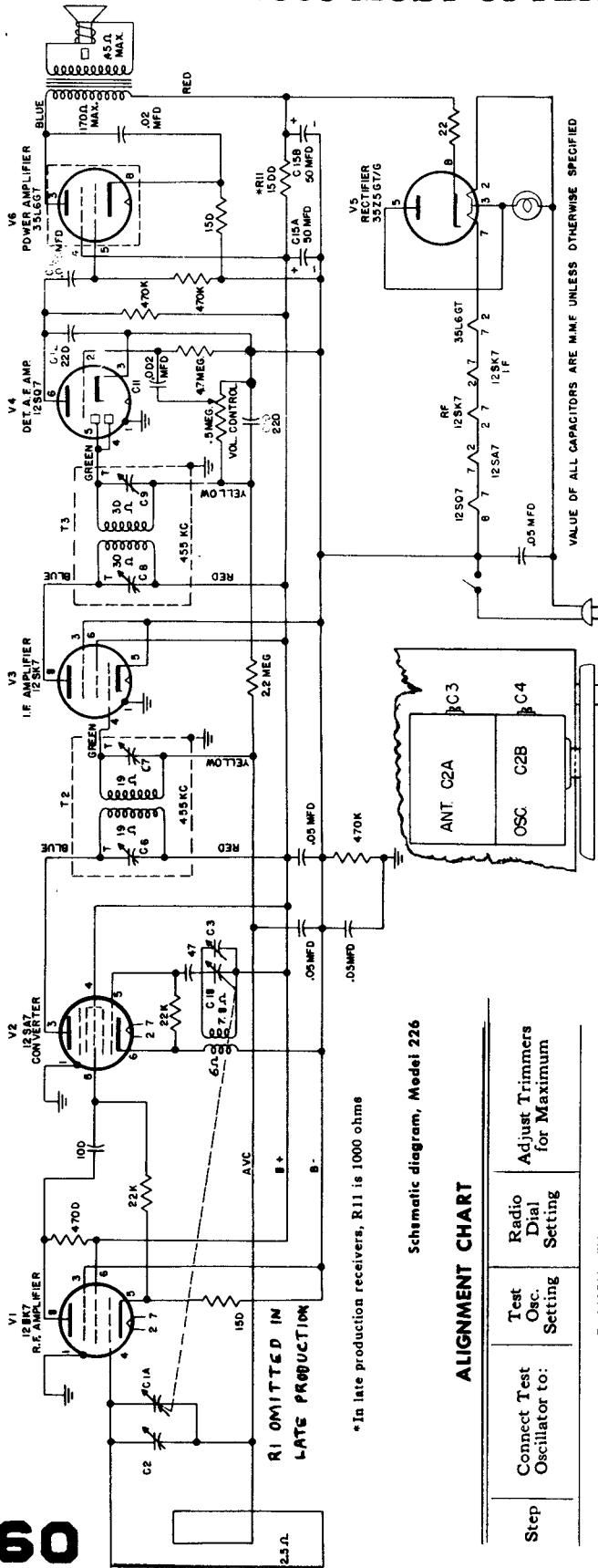

*In late production receivers, R11 is 1000 ohms

Schematic diagram, Model 226

ALIGNMENT CHART

Step	Connect Test Oscillator to:	Test Osc. Setting	Radio Dial Setting	Adjust Trimmers for Maximum
I-F ALIGNMENT				
1	V3, 12SK7 grid (Pin 4), in series with .05 mfd.	455 KC	C9 and C8 of second i-f transformer, T3
2	V2, 12SA7 grid (Pin 8), in series with .05 mfd.	455 KC	C7 and C6 of first i-f transformer, T2
3	V2, 12SA7 grid (Pin 8), in series with .05 mfd.	455 KC	Recheck adjustment of C9, C8, C7, C6, for maximum
R-F ALIGNMENT				
4	Inductively coupled to radio loop	1620 KC	Minimum capacity C1A, C1B	C3, oscillator trimmer
5	Inductively coupled to radio loop	1500 KC	1500 KC	C2, r-f trimmer

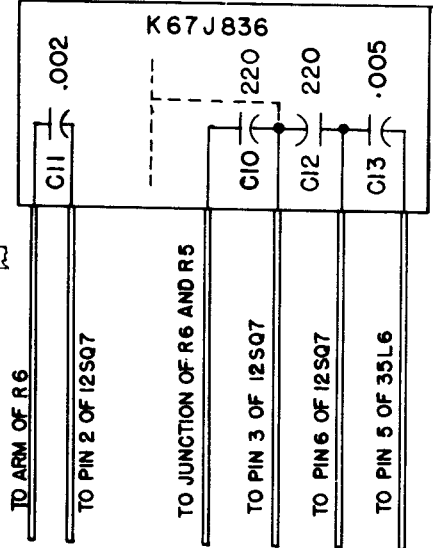

The lead connections for the four-section ceramic capacitor unit containing C10, C11, C12 and C13 are identified from the illustration.

MANUAL OF 1950 MOST-OFTEN-NEEDED RADIO DIAGRAMS

GENERAL ELECTRIC

Service data for Models 509 & 530. A number of other G.E. Clock-Radio models such as: 64, 65, 66, 67, 500, 501, 505, 506, 507, & 508 are almost identical to Model 509 and 530.

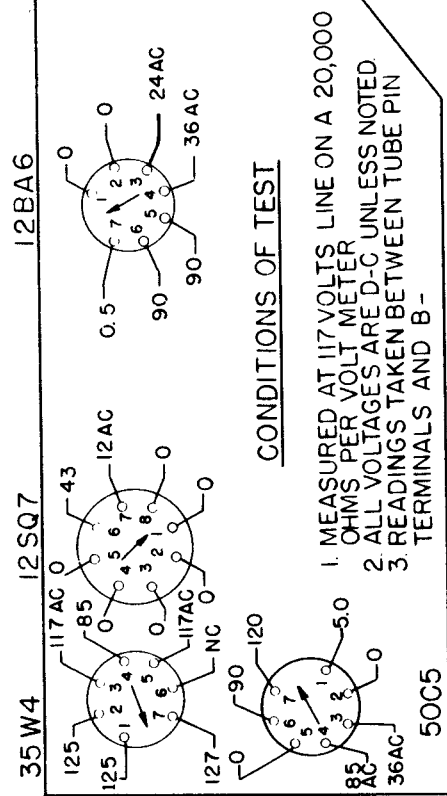
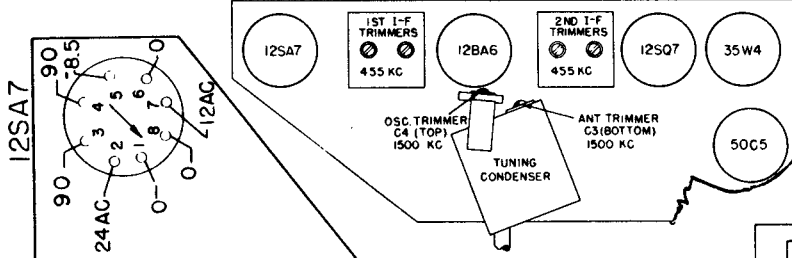

CONDITIONS OF TEST

1. MEASURED AT 117 VOLTS LINE ON A 20,000 OHMS PER VOLT METER
2. ALL VOLTAGES ARE D-C UNLESS NOTED.
3. READINGS TAKEN BETWEEN TUBE PIN TERMINALS AND B-

VIEWED FROM BOTTOM OF CHASSIS

For alignment of the oscillator and antenna trimmers, the input signal should be inductively coupled to the radio loop antenna, L1, by connecting a four-turn, six-inch diameter loop of bell wire across the signal generator output terminals, and then locating the loop to face the radio antenna loop about one foot away.

C16, C17, C19, AND C20
The lead identification for the four-section ceramic capacitor RCW-3013 (K67J836) can be observed from the illustration

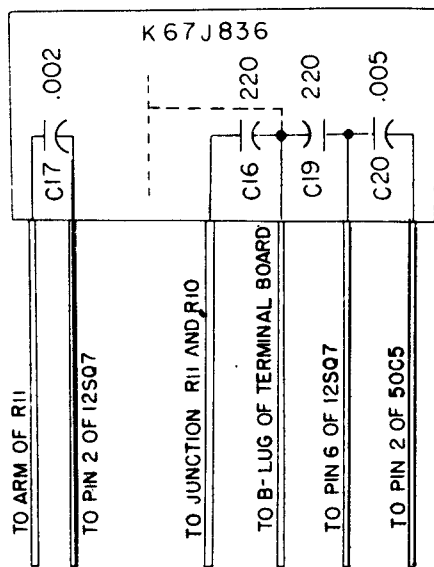

TO ARM OF R11

TO PIN 2 OF 12SQ7

TO JUNCTION R11 AND R10

TO B-B LUG OF TERMINAL BOARD

TO PIN 6 OF 12SQ7

TO PIN 2 OF 50C5

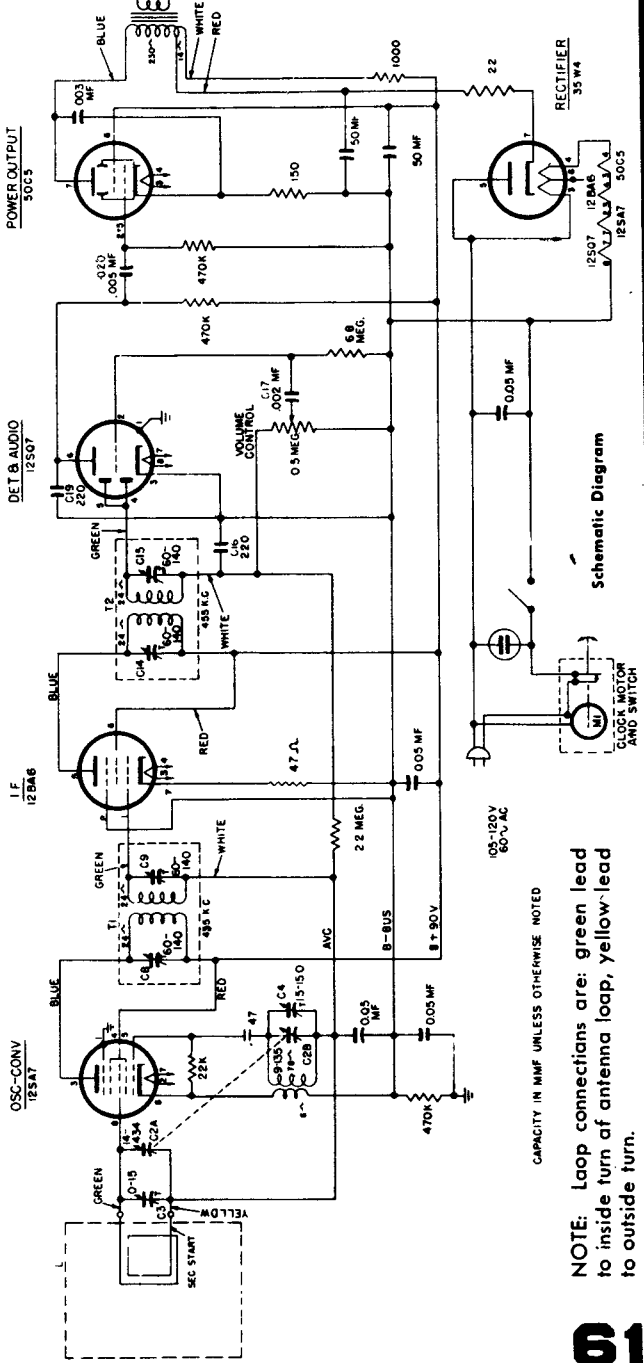

CAPACITY IN MMF UNLESS OTHERWISE NOTED

NOTE: Loop connections are: green lead to inside turn of antenna loop, yellow lead to outside turn.

WARDS

MODEL 05WG-2752

Models -2751 and -2749 are almost the same as model described here, while Model -2748 is very similar.

Alignment information is given on the back of this page.

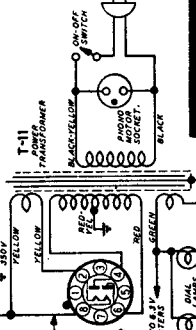
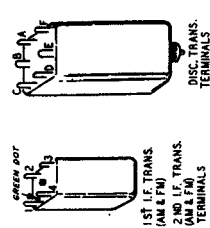
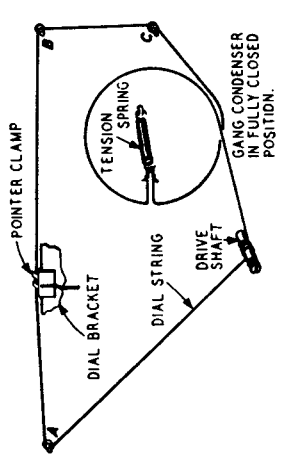
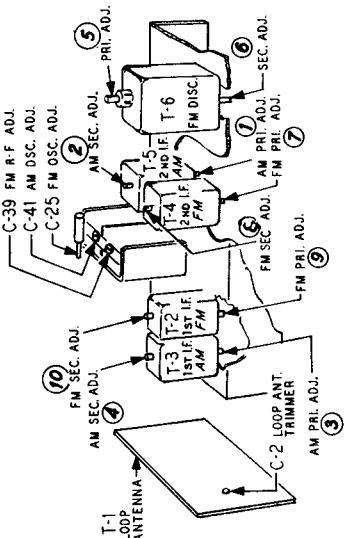
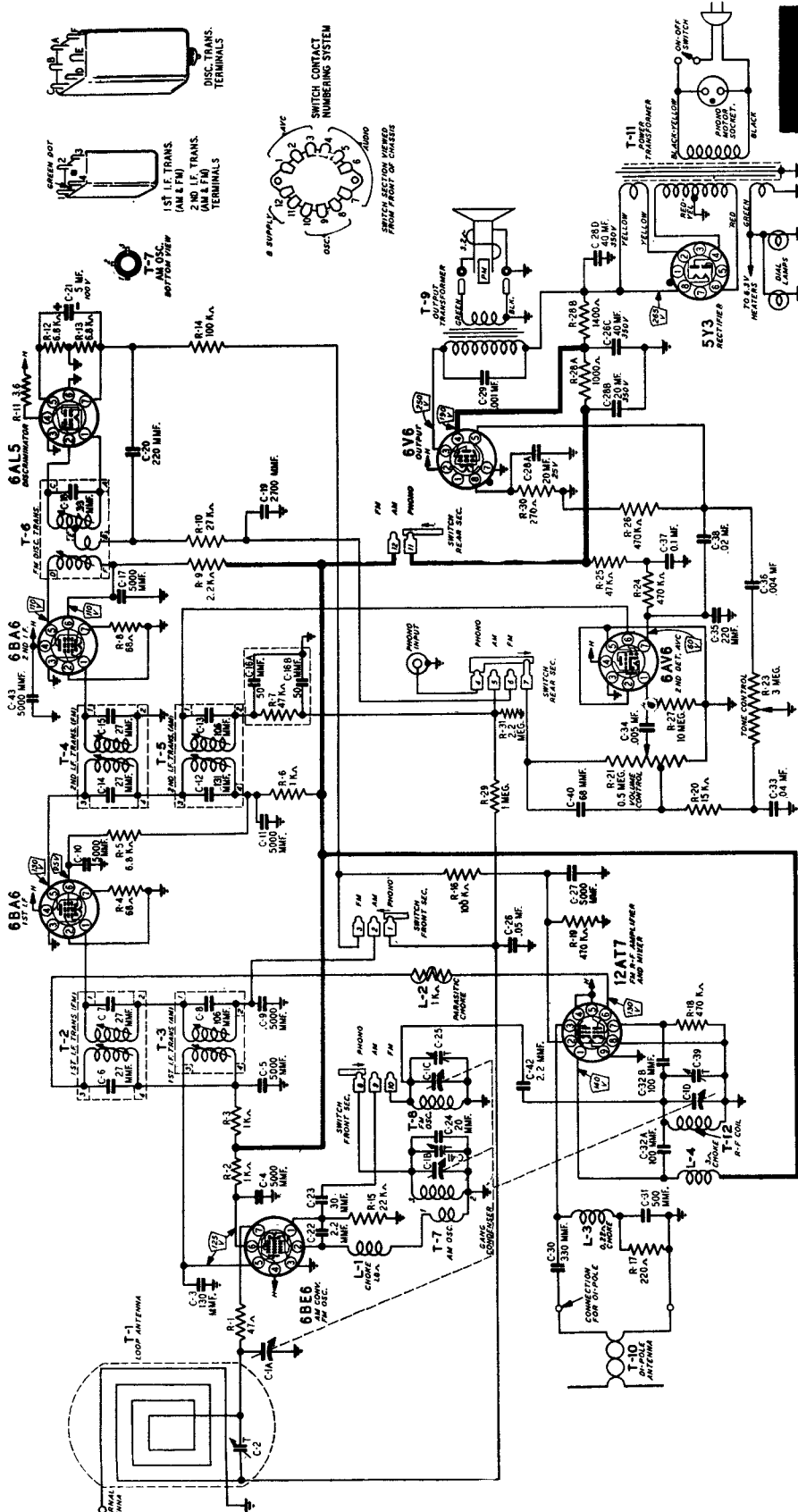

MANUAL OF 1950 MOST-OFTEN-NEEDED RADIO DIAGRAMS

ALIGNMENT PROCEDURES

MODEL 05WG-2752

AM STAGES

The following is required for aligning:

An All Wave Signal Generator Which Will Provide an Accurately Calibrated Signal at the Test Frequencies as Listed.

Output Indicating Meter, Non-Metallic Screwdriver, Dummy Antennas — .1 mf, and 50mmf.

Volume Control Maximum all Adjustments.

Connect Radio Chassis to Ground Post of Signal Generator with a Short Heavy Lead.

Allow Chassis and Signal Generator to "Heat Up" for Several Minutes.

SIGNAL GENERATOR				GANG CONDENSER SETTING	ADJUST	ADJUST FOR
FREQUENCY SETTING	CONNECT GENERATOR OUTPUT TO	THROUGH DUMMY ANTENNA	CONNECT GROUND TO			
455 KC	Control Grid 1st 6BA6 Pin No. 1	.1 mf	Chassis Base	Rotor Fully Open	2nd I.F. Pri. (1) and Sec. (2)	Maximum Output
455 KC	Control Grid 6BE6 Pin No. 7 1st Det.	.1 mf	Chassis Base	Rotor Fully Open	1st I.F. Pri. (3) and Sec. (4)	Maximum Output
455 KC	Control Grid 6BE6 Pin No. 7	.1 mf	Chassis Base	Rotor Fully Open	2nd I-F Pri. (1) and Sec. (2)	Maximum Output
1620 KC	Control Grid 6BE6 Pin No. 7	.1 mf	Chassis Base	Rotor Fully Open	Oscillator C-41	Maximum Output
1400 KC	External Antenna Lead	50 mmf	Chassis Base	Turn Rotor to Max. Output. Set Pointer to 1400 KC See Note A	Antenna C-2	Maximum Output

NOTE A—If the pointer is not at 1400 KC on the dial, reset pointer to the 1400 KC mark on the dial scale.

FM STAGES

The following is required for aligning:

An accurately calibrated signal generator providing unmodulated signals at the test frequencies listed below.

Non-metallic screwdriver.

Dummy Antennas and I-F Loading Resistor—2500 mmf, 300 ohms

Zero center scale DC vacuum tube voltmeter having a range of approximately 3 volts.

(If a zero center scale meter is not available, a standard scale vacuum tube voltmeter may be used by reversing the meter connections for negative readings).

Allow chassis and signal generator to "Heat Up" for several minutes.

SIGNAL GENERATOR			THROUGH DUMMY ANTENNA	BAND SWITCH SETTING	GANG CONDENSER SETTING	ADJUST	ADJUST FOR
	FREQUENCY SETTING	CONNECT GENERATOR OUTPUT TO					
Discriminator	10.7 MC	6BA6 2nd I-F Pin 1 and Chassis	2500 mmf	FM	Rotor Fully Open	Disc. Pri. (5) Note A	Maximum Deflection
	10.7 MC	6BA6 2nd I-F Pin 1 and Chassis	2500 mmf	FM	Rotor Fully Open	Disc. Sec. (6) Note B	
I-F	10.7 MC Note C	6BA6 1st I-F Pin 1 and Chassis	2500 mmf	FM	Rotor Fully Open	2nd I-F Pri. (7) Sec. (8) Note D	Maximum Deflection
Discriminator	10.7 MC	6BA6 1st I-F Pin 1 and Chassis	2500 mmf	FM	Rotor Fully Open	Disc. Pri. (5) Note D	Maximum Deflection
I-F	10.7 MC	Junction C-32A & B (Dual 100 mmf cond.) And chassis	2500 mmf	FM	Rotor Fully Open	1st I-F Pri. (9) & Sec. (10) 2nd I-F Pri. (7) & Sec. (8) Disc. Pri. (5) In Order Shown Note D	Maximum Deflection
	10.7 MC	Same as above	2500 mmf	FM	Rotor Fully Open	Disc. Sec. (6) Note B	Maximum Deflection

RECHECK I-F ADJUSTMENTS IN ORDER GIVEN

Oscillator	108.5	Disconnect built-in dipole antenna and connect generator to dipole terminals with resistor in series.	300 ohms	FM	Rotor Fully Open	Osc. C-25	Maximum Deflection
Antenna	104.5	Same as above	300 ohms	FM	Tune rotor for max AVC voltage	Ant. C-39	Maximum Deflection

RECHECK ANTENNA & OSC. ADJUSTMENTS IN ORDER GIVEN

FM ALIGNMENT NOTES

NOTE A—The zero center scale DC vacuum tube voltmeter is to be connected between chassis ground and the AVC line. A signal of .1 volt must be fed into the receiver for this adjustment.

Note output voltage on the zero center DC vacuum tube voltmeter

NOTE B—Disconnect zero center DC vacuum tube voltmeter from AVC and connect it at the audio takeoff point at the 27 K ohm resistor (R-10) and its junction with the terminal strip. Adjust for zero voltage indication.

NOTE C—AM I-F coils must be aligned before attempting to align the FM I-F coils.

NOTE D—Connect zero center DC vacuum tube voltmeter as in Note A. Adjust input to give some output on the zero center DC vacuum tube voltmeter as in Note A.

MANUAL OF 1950 MOST-OFTEN-NEEDED RADIO DIAGRAMS

WARDS

MODEL 05WG-2745B

MODEL 94WG-2745A

Frequency RangesBroadcast 540-1600 KC
Frequency Modulation 88-108 MC

Intermediate Frequency . . .AM—455 KC
FM—10.7 MC

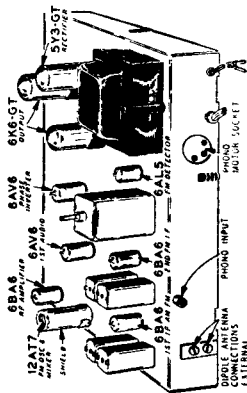
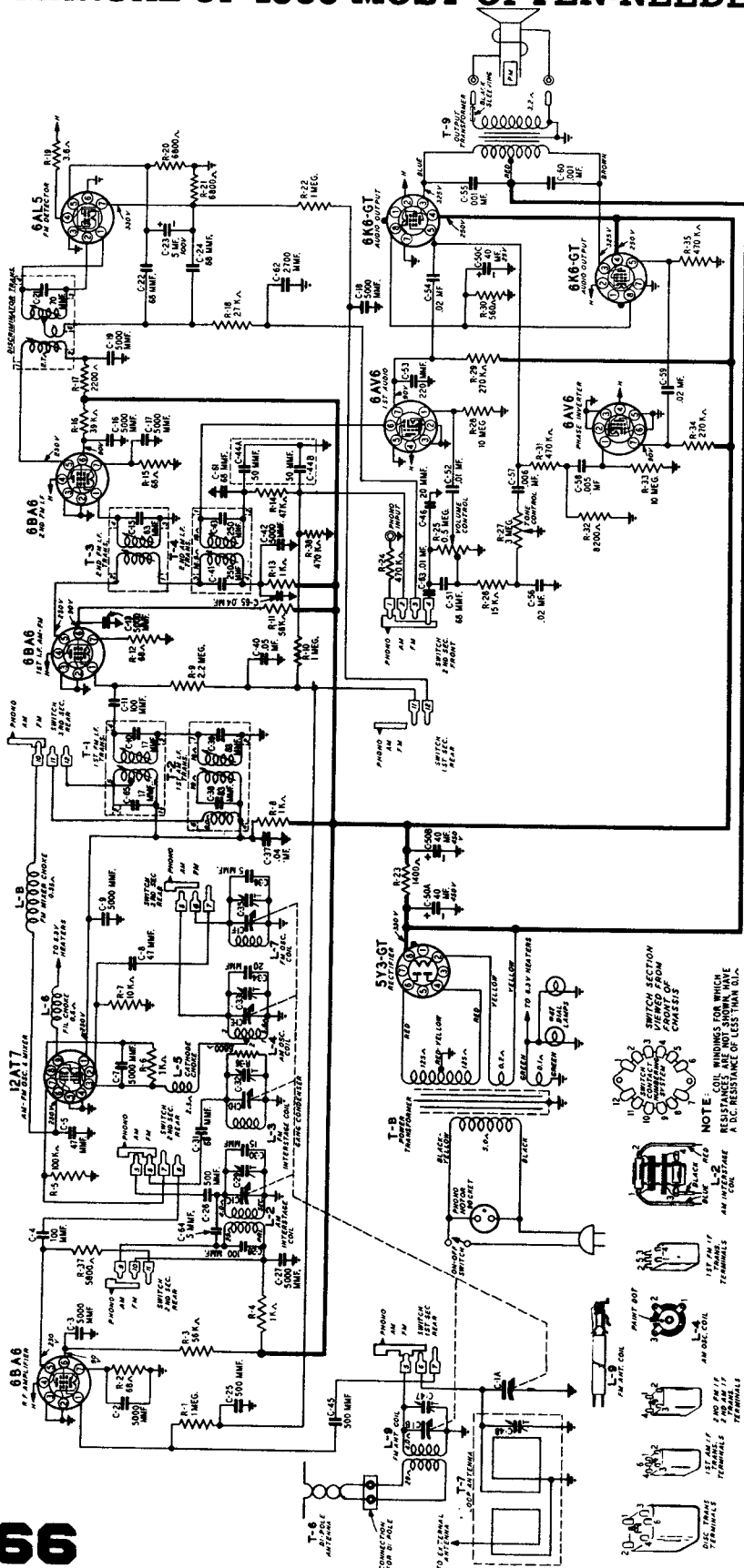

NOTE: COIL WINDINGS FOR WHICH RESISTANCES ARE NOT SHOWN HAVE A D.C. RESISTANCE OF LESS THAN 0.1.

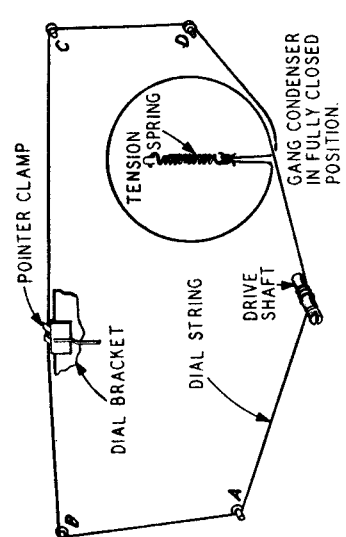
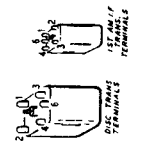
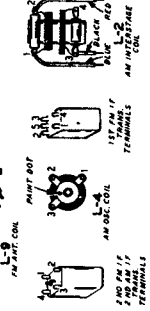

MANUAL OF 1950 MOST-OFTEN-NEEDED RADIO DIAGRAMS

WARDS *Airline* RADIO

84BR-1517A, 1518A

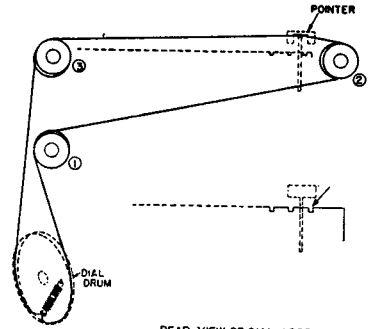
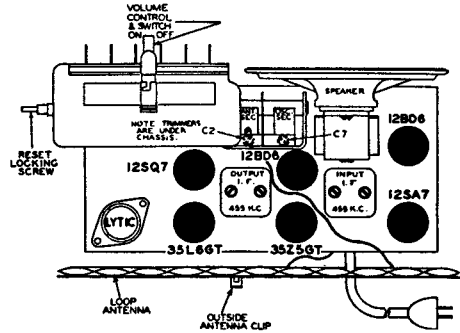

ALIGNMENT PROCEDURE AND RECEIVER STAGE SENSITIVITIES

The signal source must be an accurately calibrated signal generator capable of supplying R. F. signals modulated 30% with a 400-cycle audio signal. A 400-cycle source is necessary for the audio measurement.

The table below lists the sensitivity at various points. All measurements are based on an output of 50-milliwatts. This may be measured by disconnecting the

speaker voice coil and substituting a 3.2-ohm, 5-watt resistor across the secondary winding of the output transformer. A reading of .4 volts AC across this resistor will be equivalent to a 50-milliwatt output with the speaker connected. Variations of plus or minus 25% are usually permissible. Volume control at maximum for all adjustments.

SIGNAL GENERATOR				TUNER SETTING	ADJUST FOR MAXIMUM OUTPUT	INPUT FOR 50-MILLIWATT OUTPUT
Frequency	Coupling Capacitor	Connection to Radio	Ground Connection			
455 kc.	.1 mf.	Pin No. 8 of 12SA7	12SQ7 Pin 3	Rotor full open	Trimmers on output and input I.F. cans	100 microvolts
1650 kc.	.1 mf.	Pin No. 8 of 12SA7	12SQ7 Pin 3	Rotor full open	Oscillator trimmer C7 (on bottom)	_____
1400 kc.	none	See note A	none	Set dial at 1400	Antenna trimmer C2 (on bottom)	_____
1400 kc.	.1 mf.	External antenna clip	12SQ7 Pin 3	1400 kc.	_____	13 microvolts
400 cycles	.1 mf.	12SQ7, Pin 2	12SQ7 Pin 3	_____	_____	.05 volts

Note A: Lay output lead of generator in back of loop antenna.

Turn up generator output. Loop antenna will pick up energy.

NOTE: On some sets slug tuned I.-F.'s are used instead of trimmer tuned I.-F.'s. 108-140Q and 108-145H are trimmer tuned. B-13A-12023-1 and B-13B-12022-1 are slug tuned. The slug tuned

I.-F.'s are tuned from the top and bottom (secondary on top, primary on bottom).

When trimmer tuned I.-F.'s are used, R5 is 270 ohms.

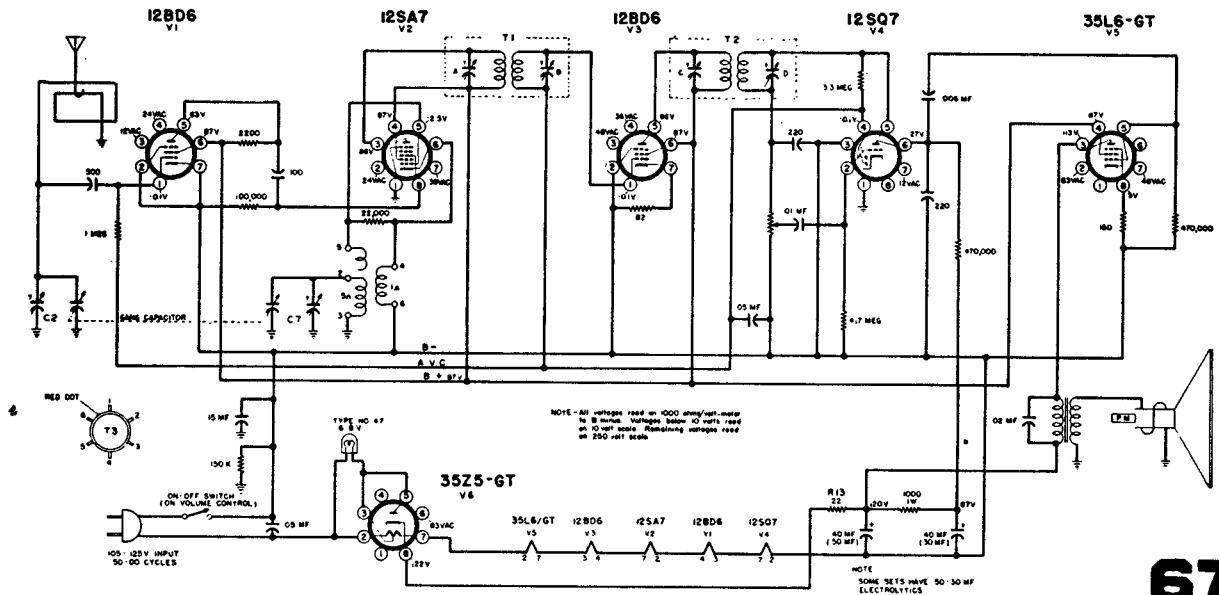

MANUAL OF 1950 MOST-OFTEN-NEEDED RADIO DIAGRAMS

M O N T G O M E R Y W A R D

MODELS 84HA1527A

84HA1528A

Intermediate Frequency. 455 KC

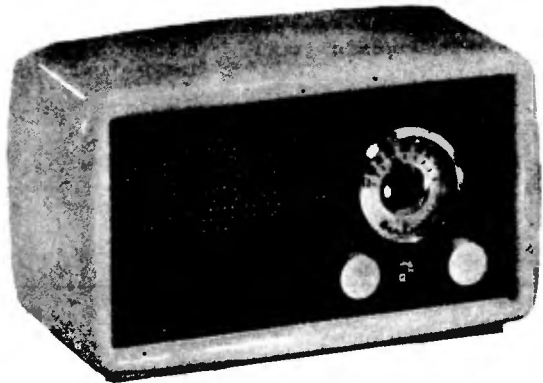

NOTES-

1. SOCKET VIEWS ARE BOTTOM VIEWS.
2. ALL VOLTAGES ARE MEASURED BETWEEN TUBE SOCKET TERMINALS AND ELECTRICAL GROUND (NOT CHASSIS) WITH ZERO SIGNAL INPUT.
3. LINE VOLTAGE.....117 V. AC.
4. ALL VOLTAGES SHOWN ARE DC UNLESS OTHERWISE SPECIFIED. AC VOLTAGES SHOWN BECOME DC WHEN OPERATING FROM A DC LINE.
5. DC VOLTAGES SHOWN WERE MEASURED WITH AN ELECTRONIC VOLTMETER.
6. "NC" NO CONNECTION. (VOLTAGE SHOWN FOR THIS TERMINAL ONLY WHEN TERMINAL IS USED AS A TIE LUG).
7. "NR" NOT READABLE. (READING GENERALLY MEANINGLESS).
8. [] SPACE PROVIDED FOR SERVICE METER READINGS.
9. ALL READINGS TAKEN WITH LINE PLUG POLARIZED SO THAT GROUND BUSS AND CHASSIS ARE AT THE SAME POTENTIAL WITH THE CHASSIS GROUNDED.

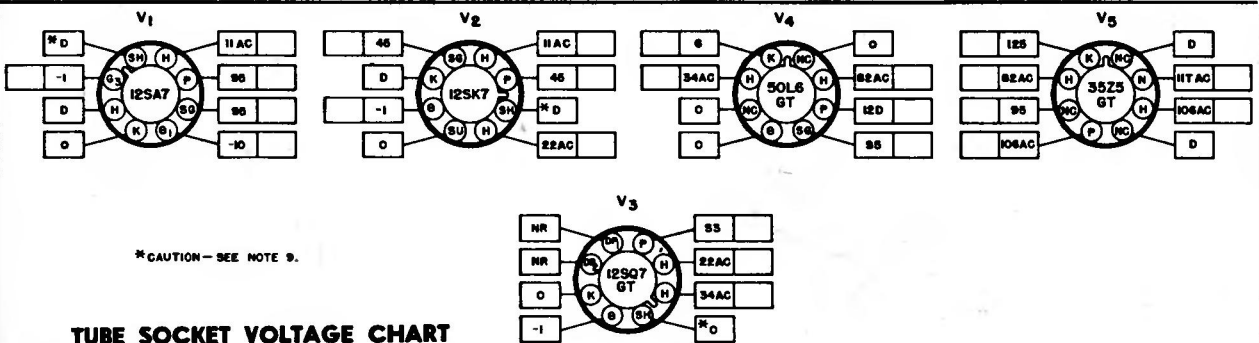

FRONT APRON

BOTTOM VIEW OF CHASSIS

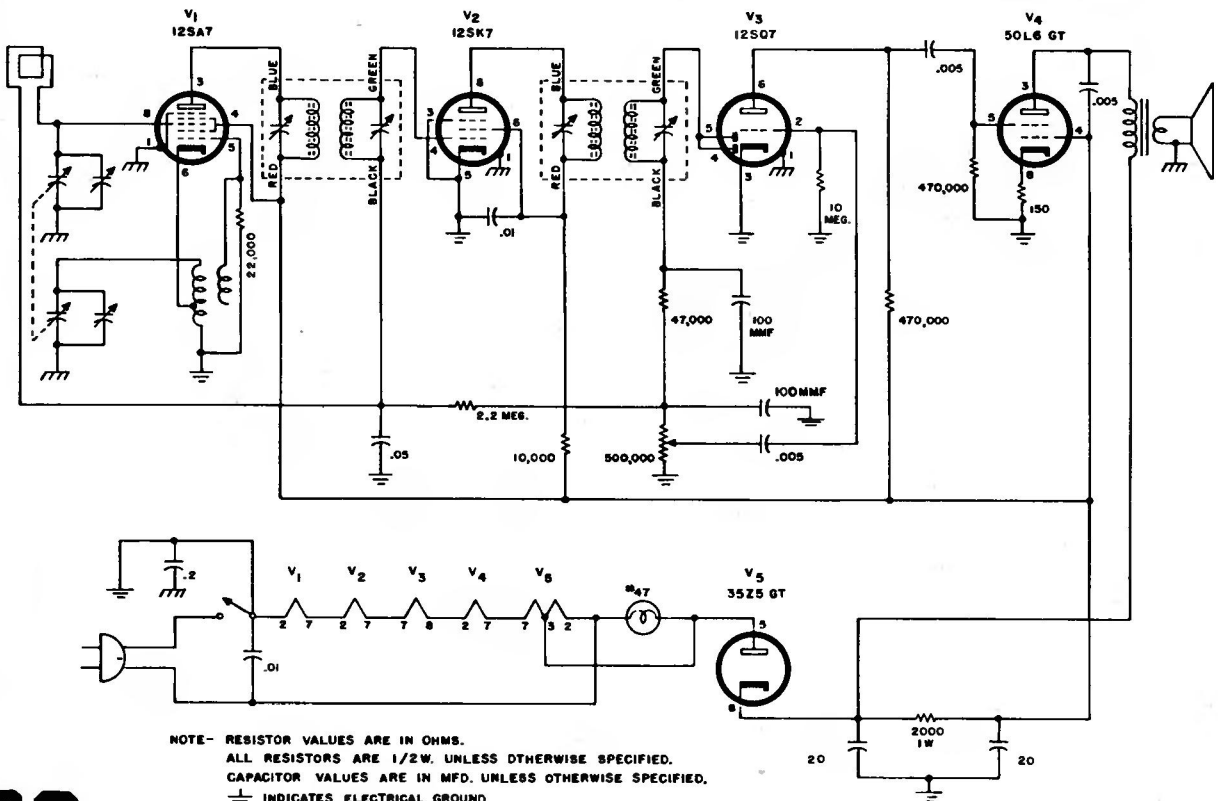

WARDS *Airline* RADIO

MODEL 94 WG-1059A

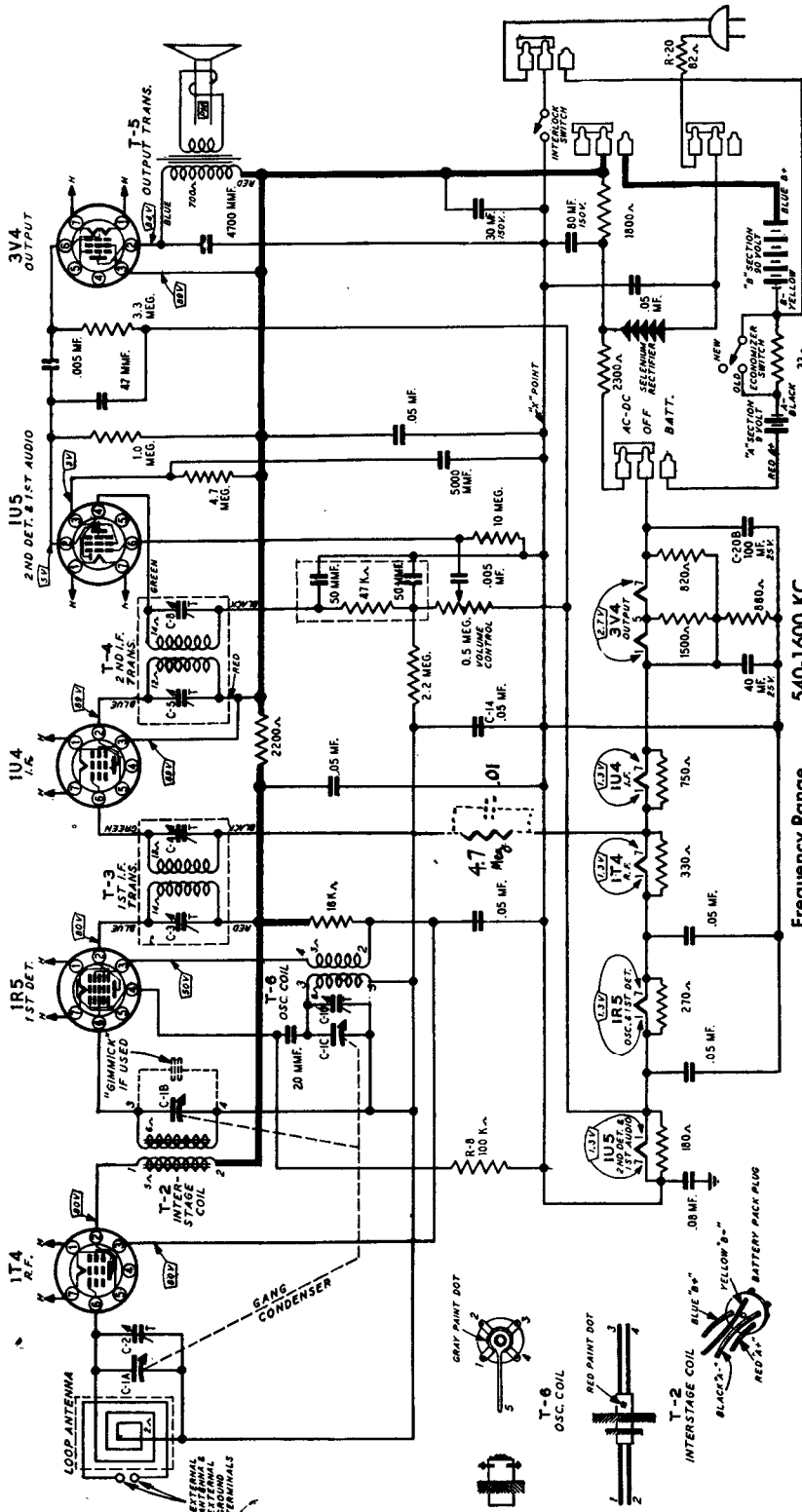

TUBE SOCKET VOLTAGES

Socket voltages are shown on the schematic diagram at the tube socket terminals with set operating on AC. All voltages except those for the filaments are between the socket terminal and "X" point.

The readings were taken with a 1000 ohm-per-volt meter and oil plate and screen voltages read on a 500 volt scale. Conditions of measurement are:

- Line voltage.....117 volts AC
 - Volume control.....maximum
 - Signal input.....none
- A variation of ±10% is usually permissible.

Frequency Range.....540-1600 KC
Intermediate Frequency, 455 KC

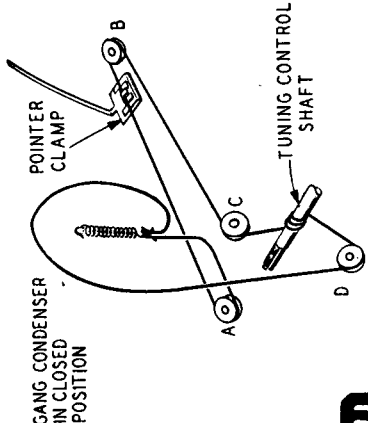
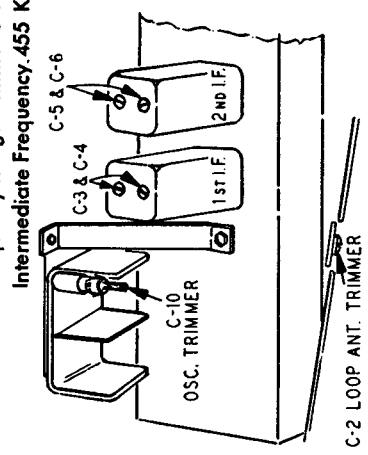

M O N T G O M E R Y W A R D

Motorola[®] AUTO Radio

MODEL
700

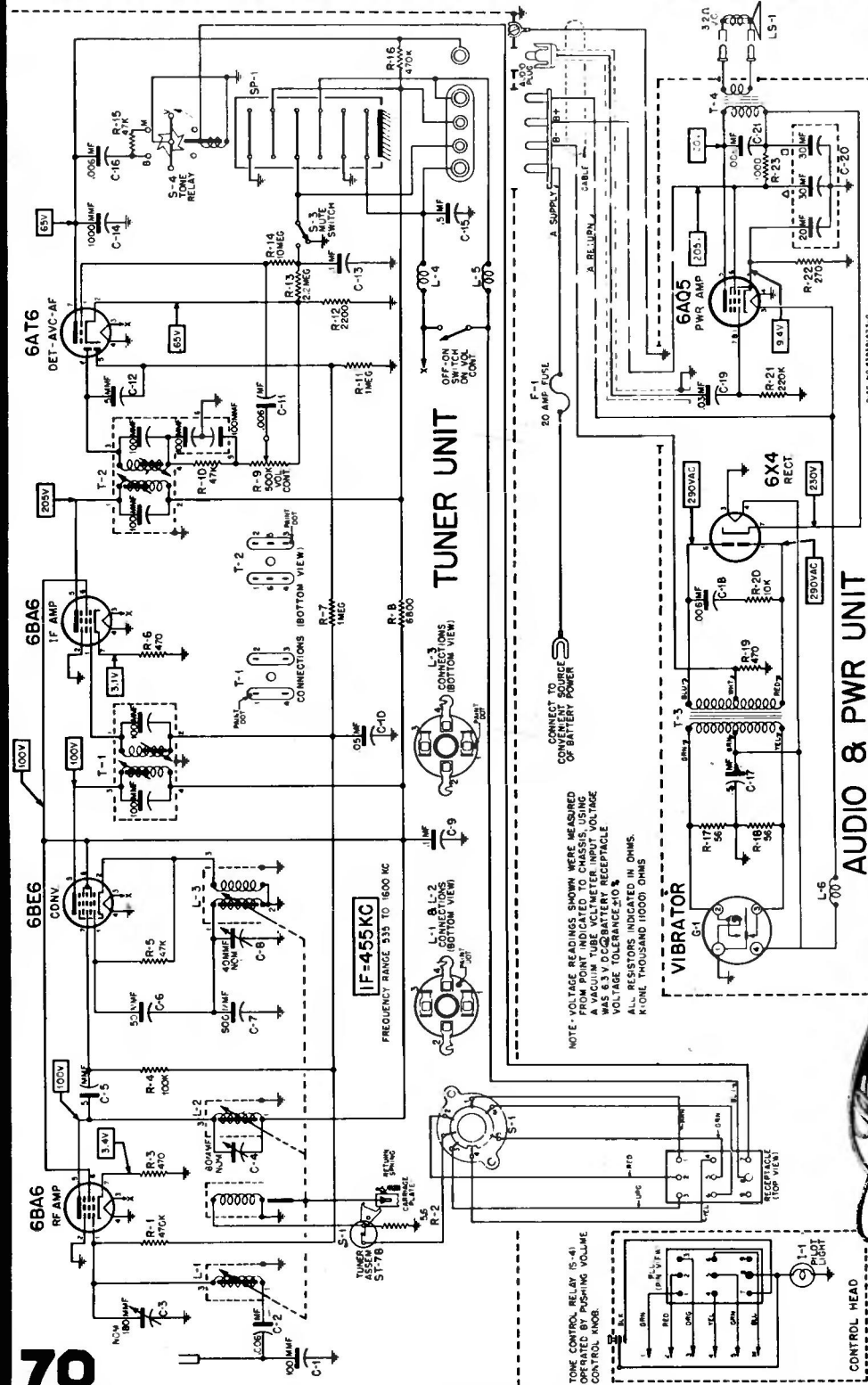

- Tuner Unit**
- 6BA6 - RF Amplifier
 - 6BE6 - Converter
 - 6BA6 - IF Amplifier
 - 6AT6 - Det-AVC-AF Amp
- Audio & Power Unit**
- 6A05 - Power Amplifier
 - 6X4 - Rectifier

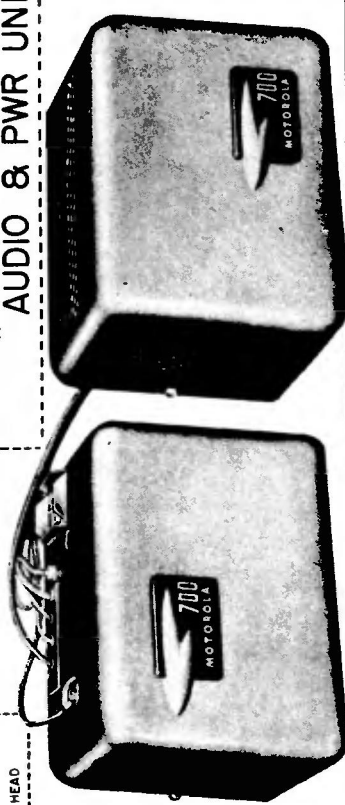

MANUAL OF 1950 MOST-OFTEN-NEEDED RADIO DIAGRAMS

Motorola Inc.

MODELS CHASSIS
 5A9B HS-62A
 5A9M HS-165
 5A9S
 5A9UB
 5A9UM

NOTE: ALL VOLTAGE MEASUREMENTS WERE TAKEN WITH A VTVM. MEASUREMENTS WERE MADE FROM POINT INDICATED BY B-(1-7). TWO READINGS ARE SHOWN; THE UPPER ONE IS FOR BATTERY OPERATION, AND THE LOWER ONE IS FOR 117 V.A.C. OPERATION. DIAL WAS SET BETWEEN STATIONS. VOLTAGE TOLERANCE ±10%.

NOTE: RESISTOR VALUES ARE INDICATED IN OHMS
 K=ONE THOUSAND (1000) OHMS.
 * BATTERY DRAIN = 150 MA AT 2.8 VOLTS.
 * BATTERY DRAIN = 85 MA AT 67.5 VOLTS.
 * RECEIVER CHASSIS
 → B-

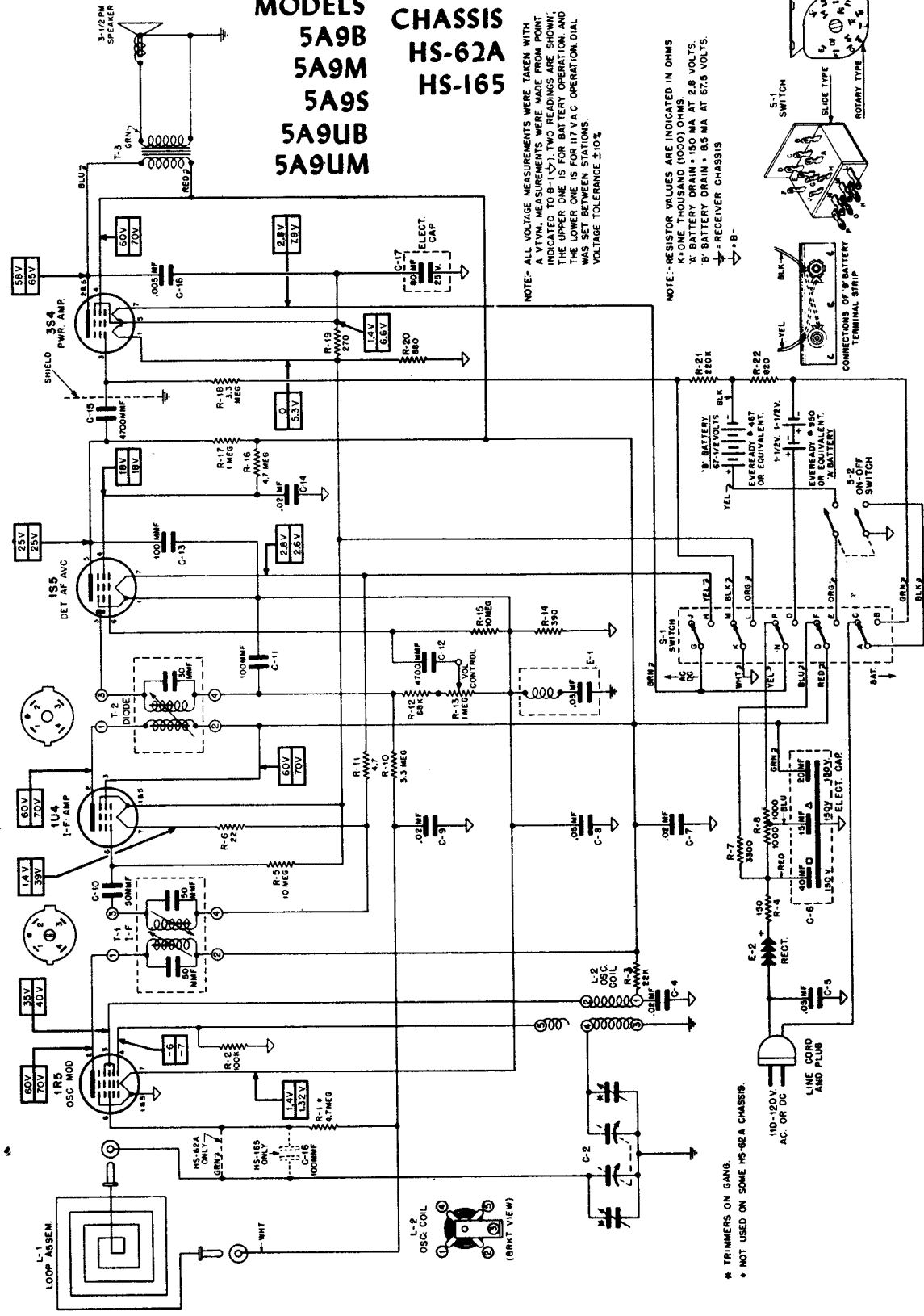
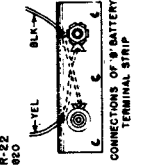
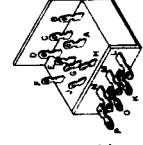
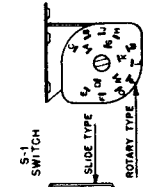

* TRIMMERS ON GANG.
 * NOT USED ON SOME HS-62A CHASSIS.

TUNING RANGE - 535 to 1620 Kc IF - 455 Kc

MANUAL OF 1950 MOST-OFTEN-NEEDED RADIO DIAGRAMS

Motorola HOME Radio

MODELS
59R11
59R12I
59R13M
59R14E

CHASSIS 59R15G
HS-167 59R16Y

ALIGNMENT

If AC power is used, use an isolation transformer between power line and receiver. If isolation transformer is not available, connect low side of signal generator to B- through .1 mf capacitor.

Connect low range output meter across speaker voice coil and set volume control at maximum. For greatest accuracy, keep output of receiver at approximately .05 watt (.05 watt = .40 volt on output meter) throughout alignment by reducing signal generator output as stages are brought into alignment. Use a small fibre screwdriver for aligning IF & diode transformers.

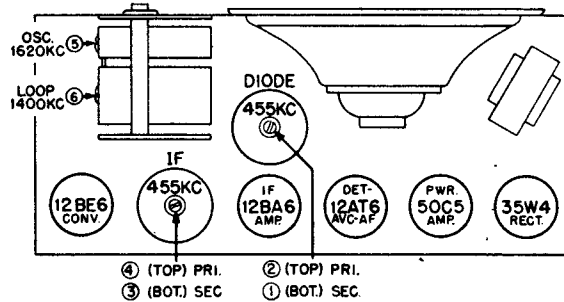

TUBE & TRIMMER LOCATION

STEP	DUMMY ANTENNA	GENERATOR CONNECTION	GENERATOR FREQUENCY	POINTER SET TO	ADJUST	REMARKS
IF ALIGNMENT						
1.	.1 mf	Rear stator of tuning cap	455 Kc	Gang opened	1, 2, 3 & 4	Adjust for maximum.
RF ALIGNMENT						
2.	"	"	1620 Kc	"	5	Adjust for maximum.
3.	None	Radiation loop*	1400 Kc	Tune for maximum	6	Adjust for maximum.

* Connect generator output to 5" diameter, 3 turn loop & couple to receiver loop. Keep loops at least 12" apart.

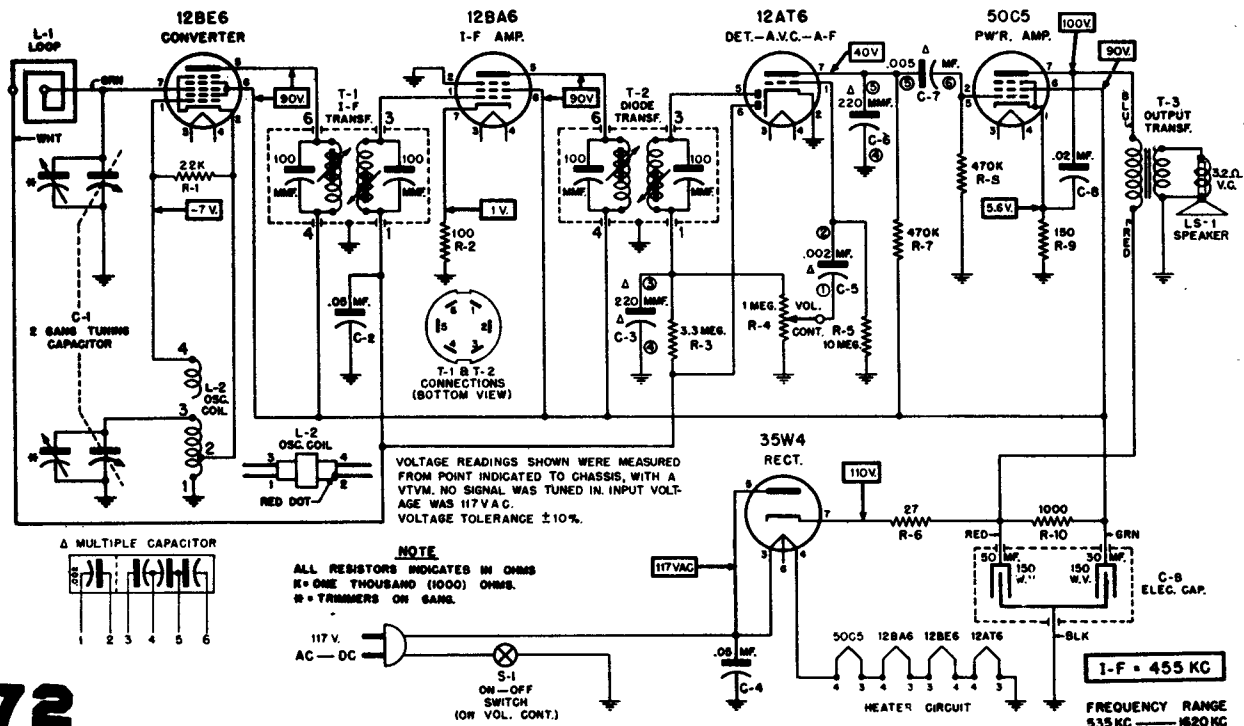

Motorola Inc.

CHASSIS
HS-168

MODELS
79XM21
79XM22

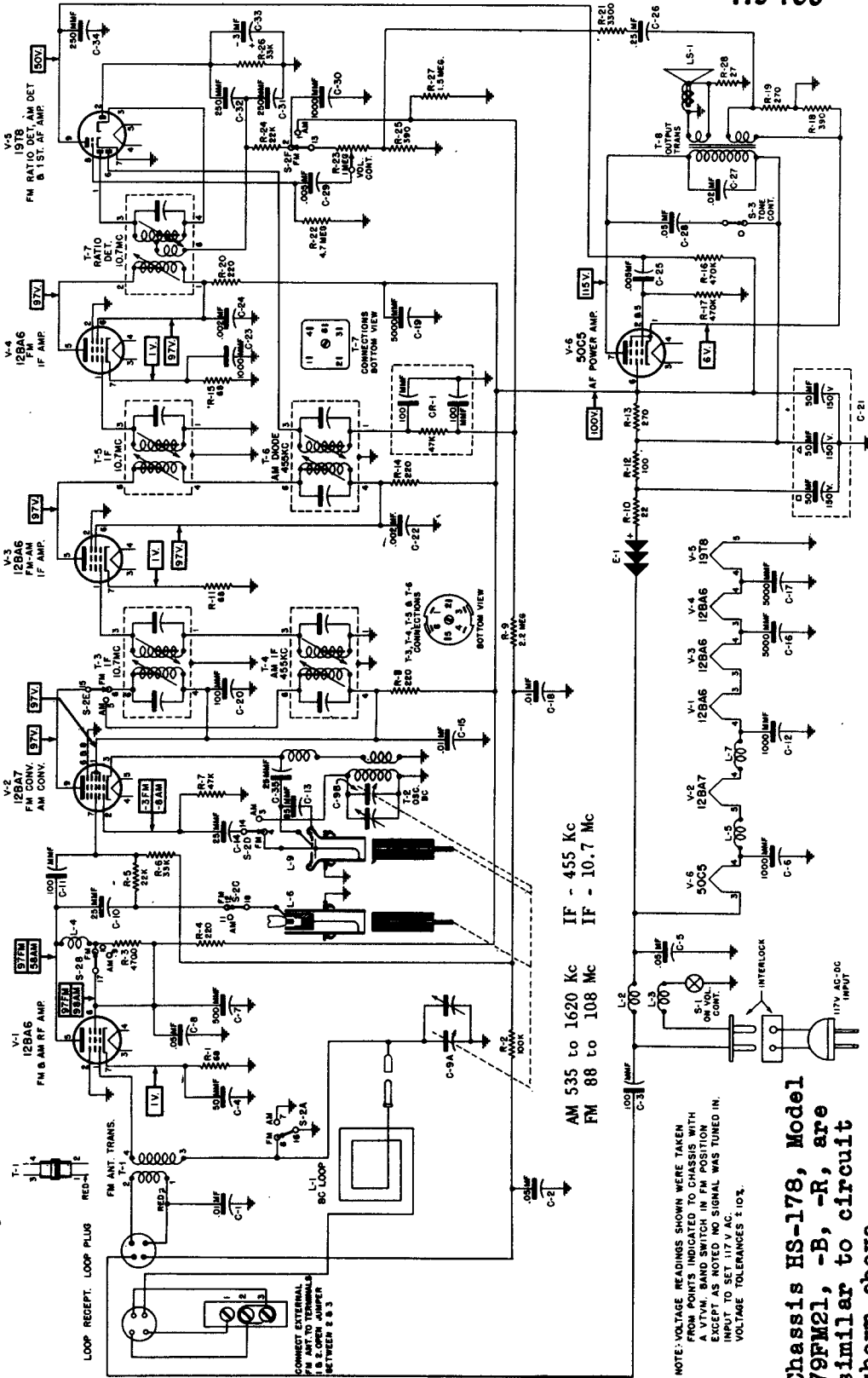

TO REMOVE CHASSIS FROM CABINET

1. Remove the pointer by setting it to either end of the dial scale and then lift the tip slightly above top of the cabinet. Now grasp the pointer tip with the fingers and screw it out of the pointer shaft (similar to removing a screw).
2. Remove the control knobs; they pull off.
3. Remove the four screws and washers that hold the back cover to the cabinet and remove the back cover.
4. Remove the two screws that hold the chassis to cabinet and slide the chassis from the cabinet.

Chassis HS-178, Model 79FM21, -B, -R, are similar to circuit shown above.

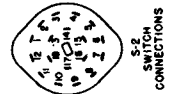

MANUAL OF 1950 MOST-OFTEN-NEEDED RADIO DIAGRAMS

MODEL
69LII
CHASSIS
HS-175

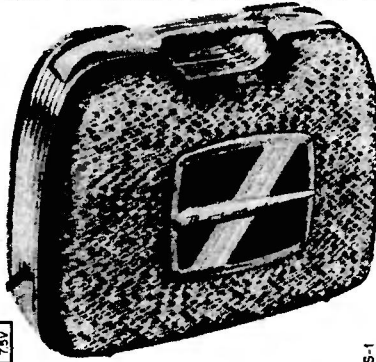

Motorola Inc.

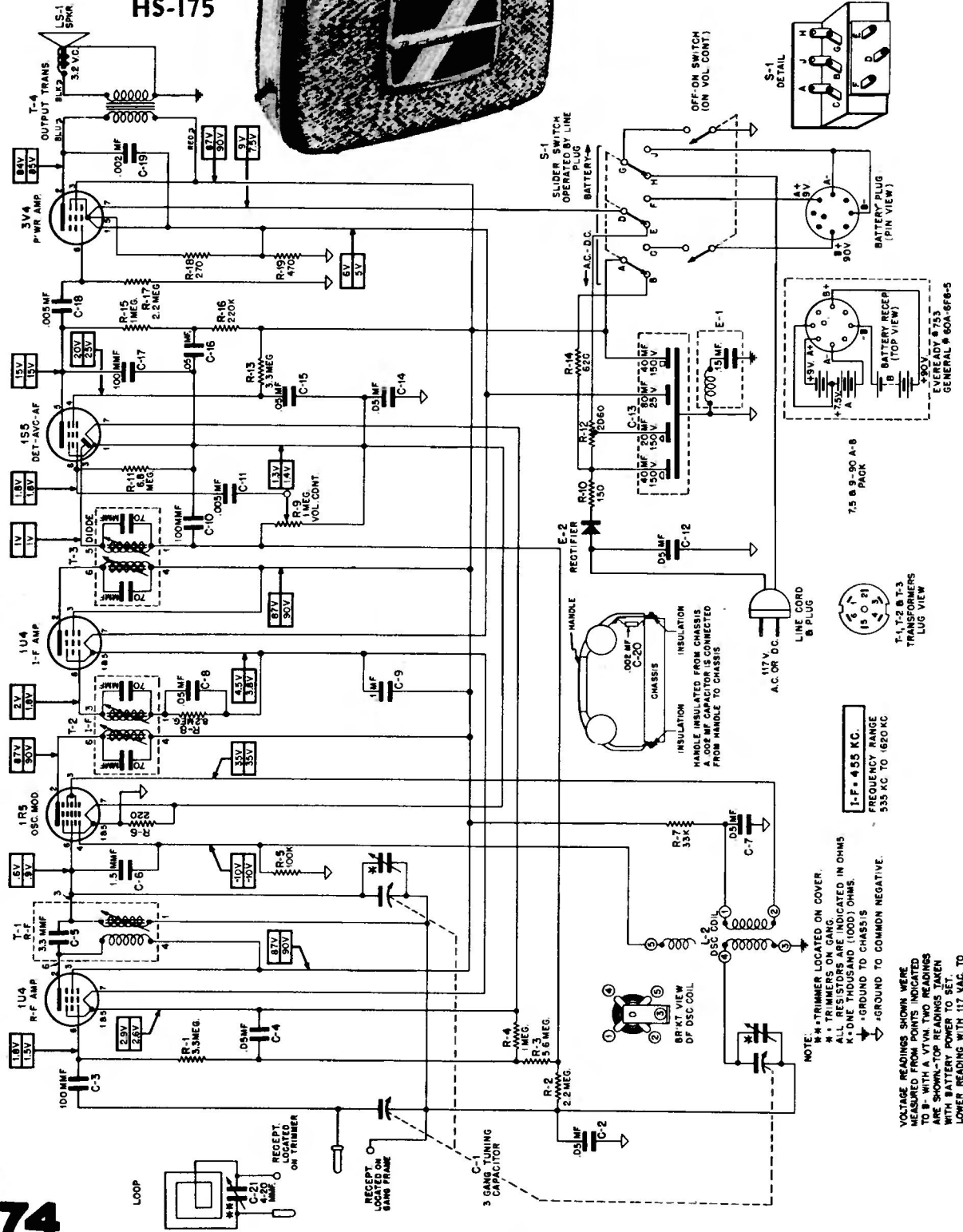

MANUAL OF 1950 MOST-OFTEN-NEEDED RADIO DIAGRAMS

Motorola Inc.

MODELS
69X11
69X12I
CHASSIS
HS-181

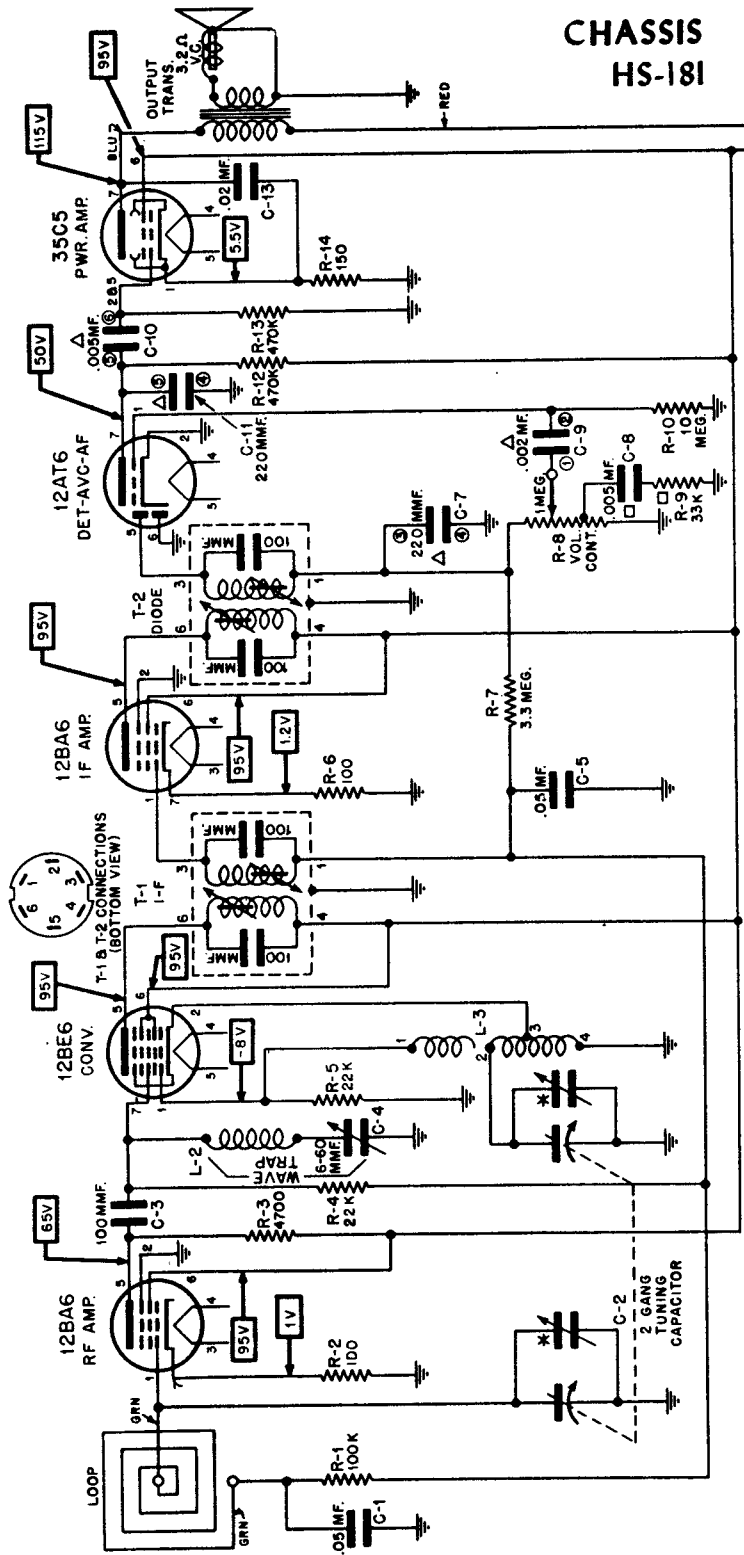

VOLTAGE READINGS SHOWN WERE MEASURED FROM POINT INDICATED TO CHASSIS WITH A VTVM. NO SIGNAL WAS TUNED IN. INPUT VOLTAGE WAS 117 VAC. VOLTAGE TOLERANCE ± 10%.

NOTE:- ALL RESISTORS ARE INDICATED IN OHMS.
K= ONE THOUSAND (1000) OHMS.
* = TRIMMERS ON GANG.

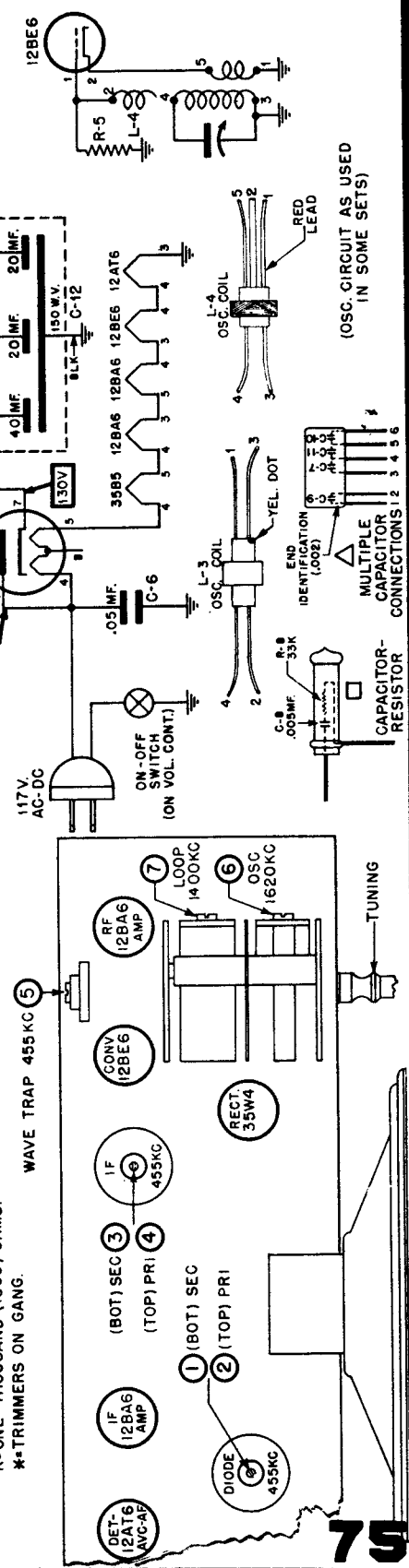

Motorola HOME Radio

MODELS

49LI1Q

49LI3Q

CHASSIS

HS-183

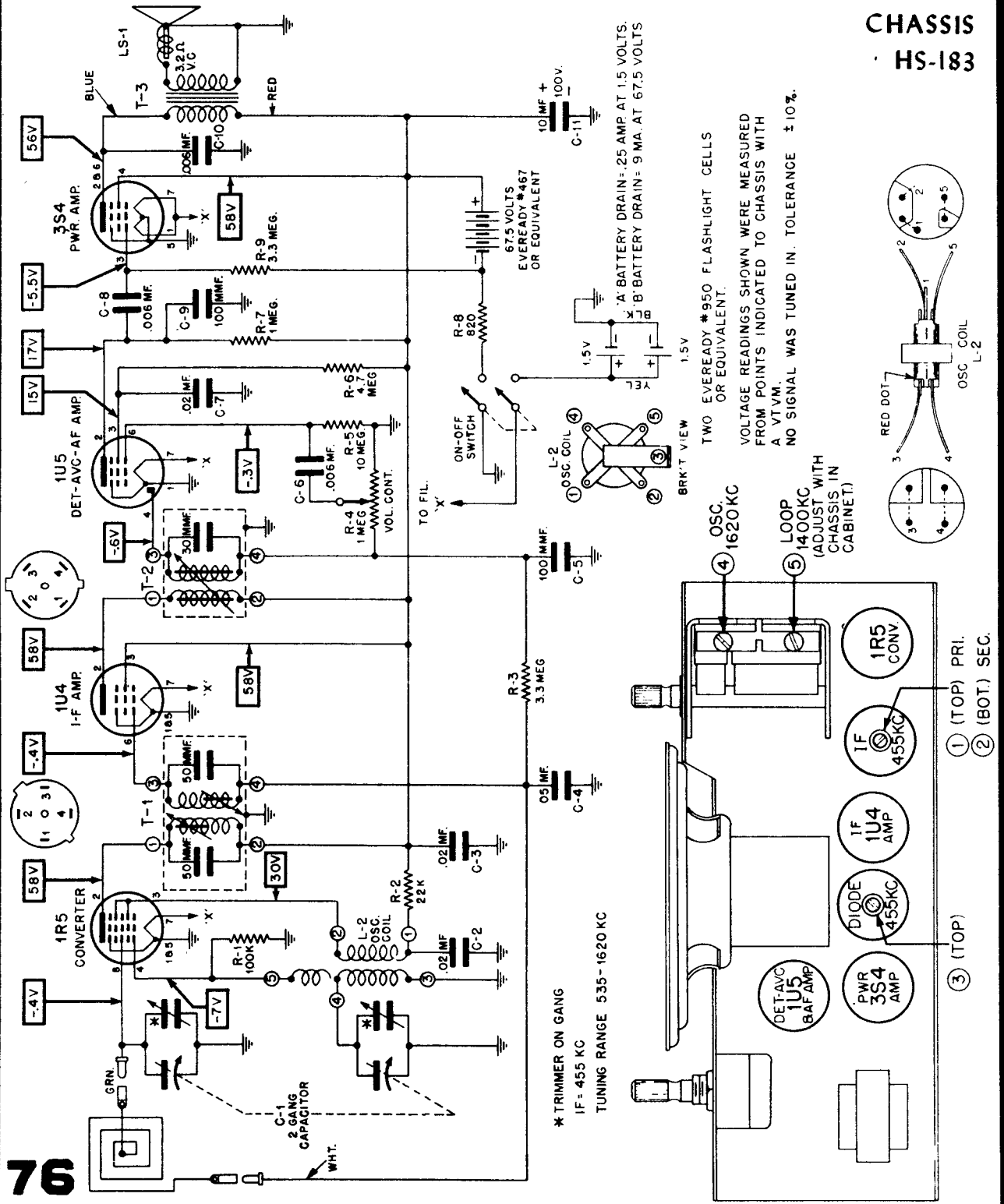

MANUAL OF 1950 MOST-OFTEN-NEEDED RADIO DIAGRAMS

Motorola Inc.

MODELS 58RI5A
58RIIA 58RI6A
58RI2A CHASSIS
58RI3A HS-184
58RI4A

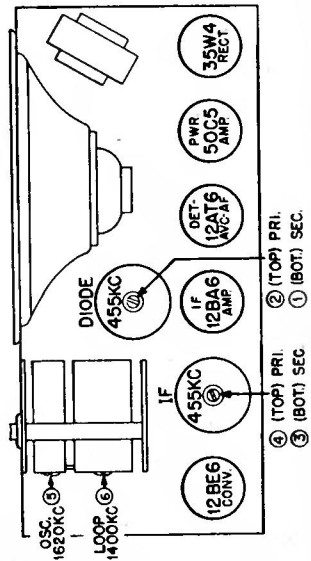
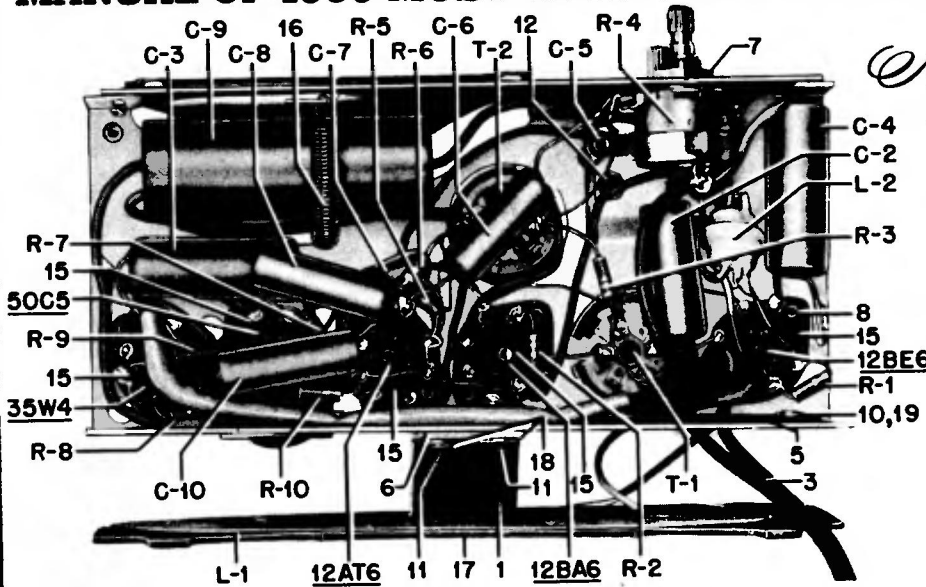

STEP	DUMMY ANTENNA	GENERATOR CONNECTION	GENERATOR FREQUENCY	POINTER SET TO	ADJUST
IF ALIGNMENT 1.	.1 mf	Rear stator of tuning cap	455 Kc	Gang opened	1, 2, 3 & 4
RF ALIGNMENT 2.	"	"	1620 Kc	"	5
3.	None	Radiation loop*	1400 Kc	Tune for maximum	6

* Connect generator output to 5" diameter, 3 turn loop & couple to receiver loop. Keep loops at least 12" apart.

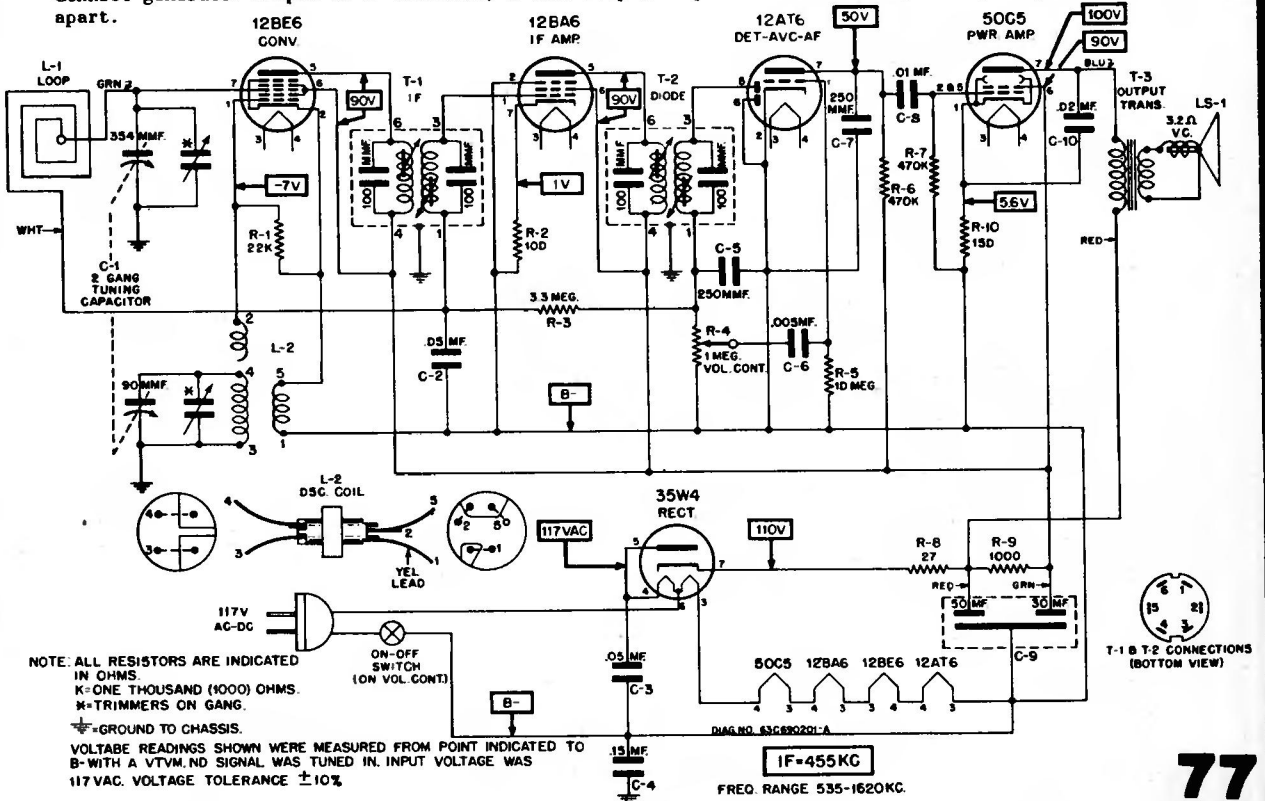

MANUAL OF 1950 MOST-OFTEN-NEEDED RADIO DIAGRAMS

Motorola Inc.

MODELS
59H11
59H121
CHASSIS
HS-206

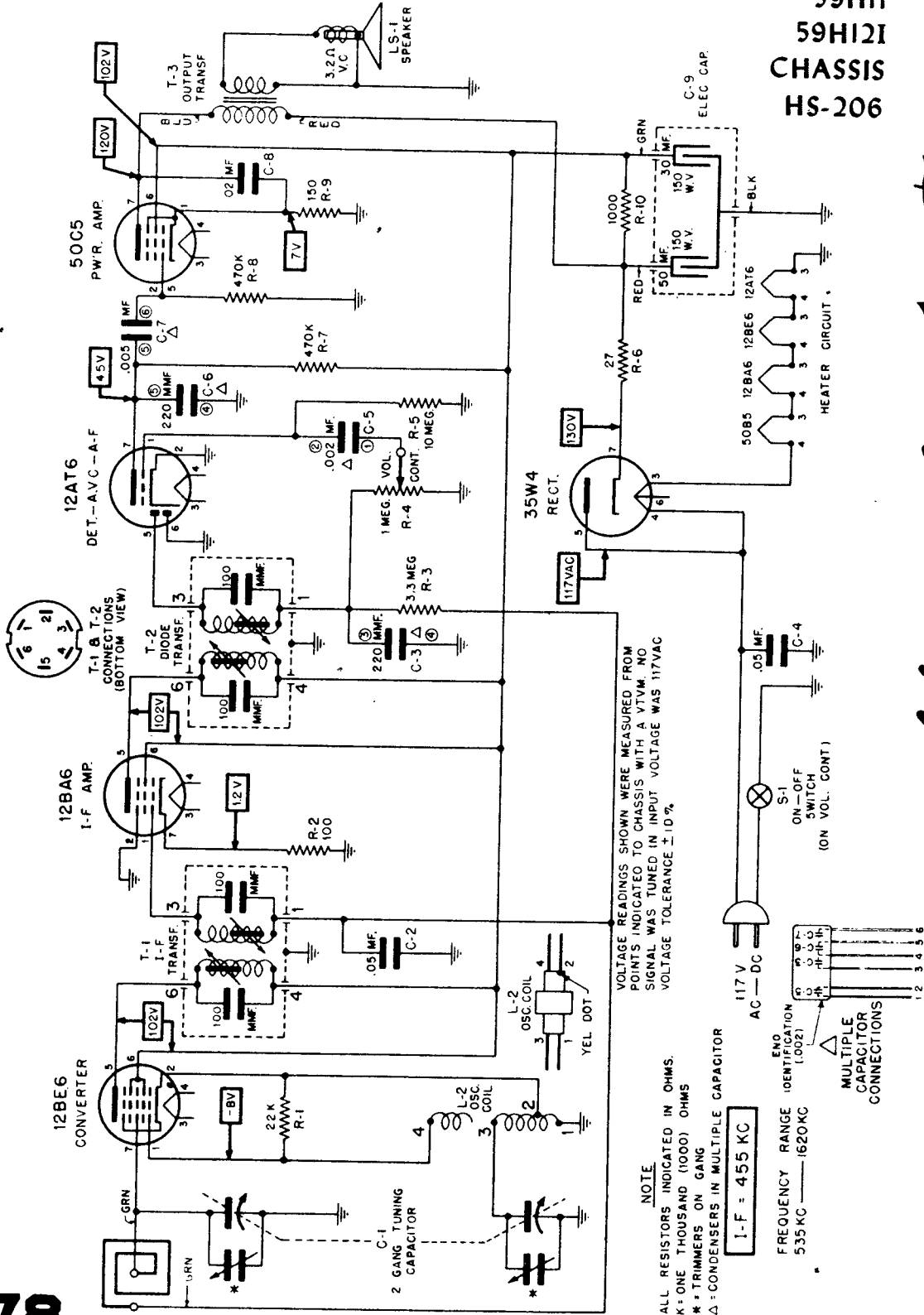

Motorola HOME Radio

VOLTAGE READINGS SHOWN ARE MEASURED FROM POINTS INDICATED TO CHASSIS WITH A VTVM. NO SIGNAL WAS TUNED IN. INPUT VOLTAGE WAS 117VAC. VOLTAGE TOLERANCE ± 10%.

NOTE
ALL RESISTORS INDICATED IN OHMS.
K = ONE THOUSAND (1000) OHMS
M = MILLI (0.001) OHMS
* = TRIMMERS ON GANG
Δ = CONDENSERS IN MULTIPLE CAPACITOR

I-F = 455 KC

FREQ. RANGE IDENTIFICATION (1002)
535 KC — 1620 KC

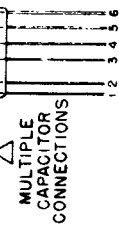

MANUAL OF 1950 MOST-OFTEN-NEEDED RADIO DIAGRAMS

Motorola Inc.

MODELS
59L11Q
59L12Q
59L14Q
CHASSIS
HS-187

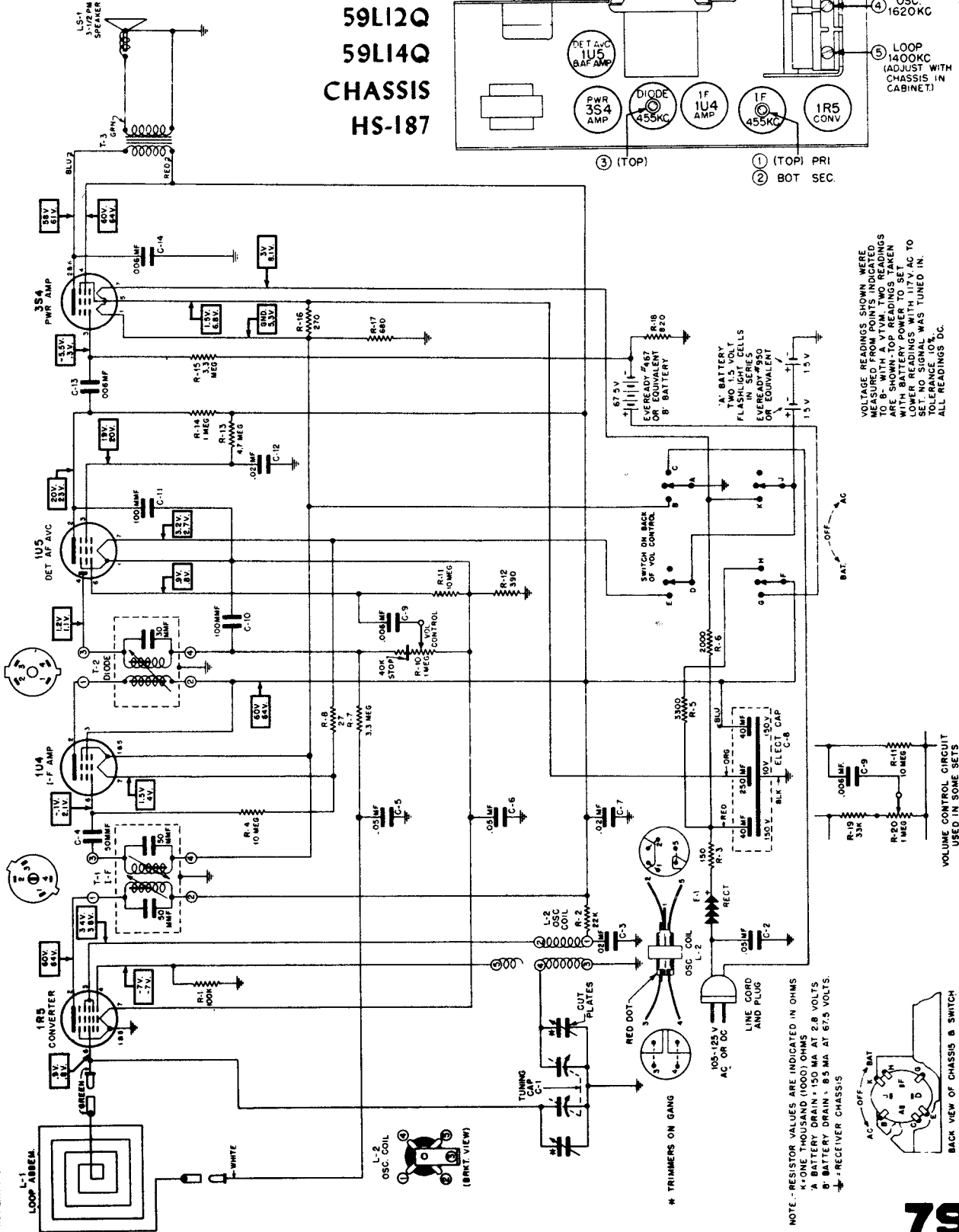
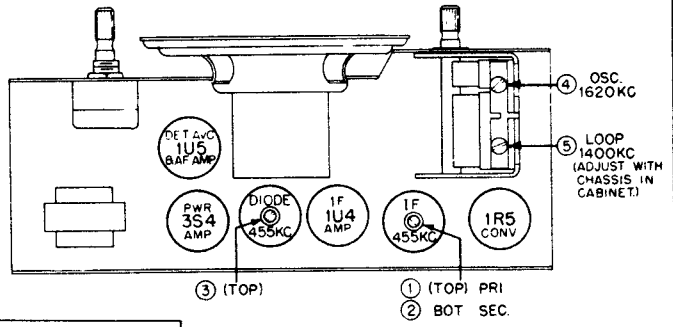

VOLTAGE READINGS SHOWN WERE MEASURED FROM POINTS INDICATED TO B- WITH A VTVM. TWO READINGS ARE SHOWN IN SERIES TO GET LOWER READINGS WITH 117V AC TO SET. NO SIGNAL WAS TUNED IN. TOLERANCE 10%. ALL READINGS DC.

NOTE: - RESISTOR VALUES ARE INDICATED IN OHMS
K - ONE THOUSAND (1000) OHMS
M - ONE THOUSAND (1000) OHMS
A - BATTERY DRAIN - 150 MA AT 2.8 VOLTS
B - BATTERY DRAIN - 8.5 MA AT 67.5 VOLTS
C - RECEIVER CHASSIS

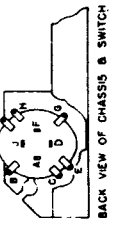
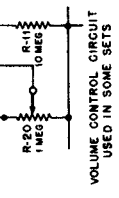

MANUAL OF 1950 MOST-OFTEN-NEEDED RADIO DIAGRAMS

Motorola

MODELS
5M1
5M1U
5M2
5M2U

CHASSIS
HS-223
HS-249

The following models are very similar:

5L1, 5L1U
 5J1, 5J1U

Chassis
 HS-224,
 HS-250.

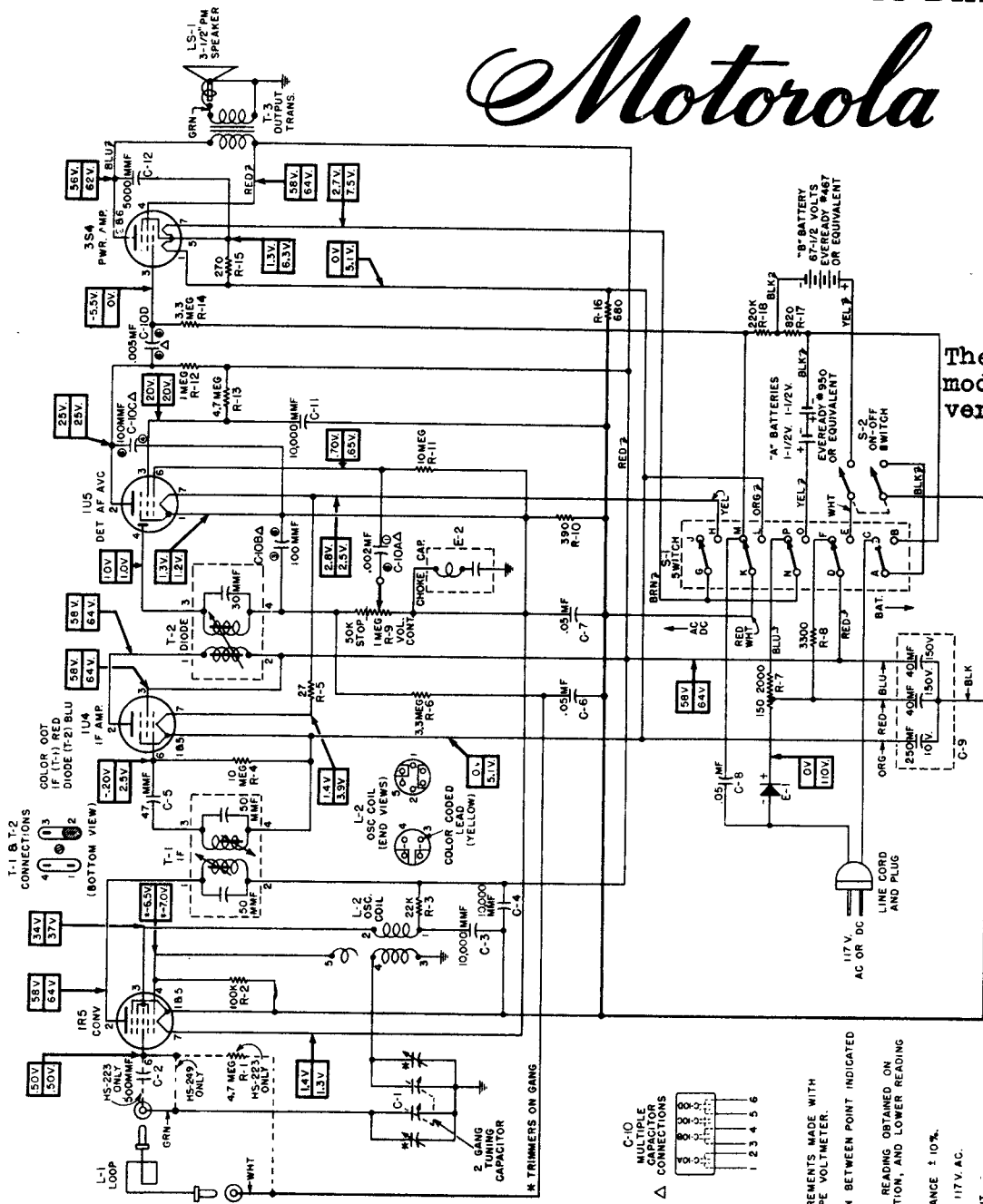

T-1 B-T2 CONNECTIONS

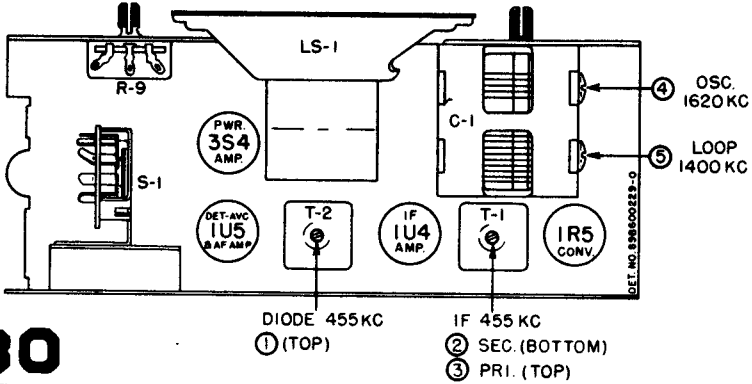

IF = 455 KC
 FREQ. RANGE
 555-1620 KC.

- NOTES:-
- VOLTAGE MEASUREMENTS MADE WITH ELECTRONIC TYPE VOLTMETER.
 - VOLTAGES TAKEN BETWEEN POINT INDICATED AND B+.
 - UPPER VOLTAGE READING OBTAINED ON BATTERY OPERATION, AND LOWER READING ON AC.
 - VOLTAGE TOLERANCE ± 10%.
 - INPUT VOLTAGE 117V. AC.
 - NO SIGNAL INPUT.
 - * MEASUREMENT MADE WITH GANG FULLY OPEN.

NOTE:
 RESISTOR VALUES ARE INDICATED IN OHMS.
 K = ONE THOUSAND (1000) OHMS.
 "A" BATTERY DRAIN = 150 MA AT 2.8 VOLTS.
 "B" BATTERY DRAIN = 8.5 MA AT 67.5 VOLTS.



MANUAL OF 1950 MOST-OFTEN-NEEDED RADIO DIAGRAMS

Motorola **HOME** Radio

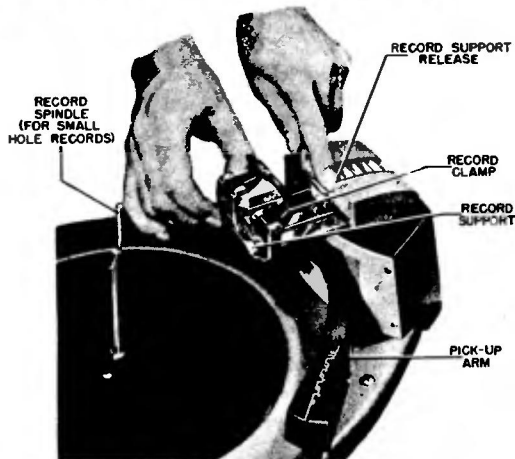

RECORD CHANGER

MODEL RC-36

To adjust the RECORD SUPPORT, press down on the RECORD SUPPORT RELEASE and move the record support to the desired position.

FIGURE 1. RECORD SUPPORT ADJUSTMENT

PHONOGRAPH CONTROLS

SPEED. The SPEED control determines the speed at which the turntable revolves. You must set this control to the position corresponding to the playing speed of the records you wish to play, viz., record speed 33 RPM, SPEED control to 33; record speed 45 RPM (large center-hole records), SPEED control to 45; or record speed 78 RPM, SPEED control to 78.

CAUTION: The SPEED control can only be moved clockwise from a playing speed position, but may be moved counterclockwise or clockwise, one position, from an OFF position. To stop turntable - rotate SPEED control clockwise.

REJECT. The REJECT control is momentarily turned clockwise and released to start playing action or to reject a record before it has completely played.

OPERATING PROCEDURE

1. Turn the radio power switch "on" and the phono-radio control to the "phono" position.
2. Select the appropriate center post for the records you desire to play.
 - a. Two spindles are provided; one spindle for small-hole records and one for large-hole records.
 - b. To play small center-hole records, insert the small diameter spindle into the hole in the center of the turntable and rotate the spindle until the pin of the spindle drops into the slot in the turntable bushing.
 - c. To play large center-hole records, insert the large diameter spindle into the turntable hole and turn the spindle counterclockwise until the spindle reaches a stop. NOTE: If the two metal separator discs of the large spindle are seen protruding from the spindle, turn the spindle shaft until they disappear inside the spindle, then insert the spindle into the turntable.
 - d. To remove a spindle from the turntable, merely lift the spindle straight up from the turntable.
3. Adjust the RECORD SUPPORT to the correct position according to the size record you desire to play.
 - a. Three positions of the record support are provided, i.e., a separate position for playing 7-inch, 10-inch, and 12-inch records (see Figure 2).
 - b. To adjust the RECORD SUPPORT press down on the RECORD SUPPORT RELEASE and move the RECORD SUPPORT to the correct position according to the size records being played. The RECORD SUPPORT will lock in position (see Figure 1). NOTE: Although the ledge of the RECORD SUPPORT is not used when playing 7-inch 45 RPM records, the RECORD SUPPORT must be in the 7-inch playing position.
4. Load the records.
 - a. Raise the RECORD CLAMP to a vertical position.
 - b. Place a stack of records over the center post in the desired sequence, with the last record to be played on top.
 - c. Rest the records on the ledge of the RECORD SUPPORT and on the off-set of the spindle when playing small-hole records. If you are playing large-hole records, place the records over the spindle and rest them on the off-sets of the large spindle.

MANUAL OF 1950 MOST-OFTEN-NEEDED RADIO DIAGRAMS

MOTOROLA Record Changer Model RC-36, continued

- d. Gently lower the RECORD CLAMP on the records. NOTE: DO NOT LOWER THE RECORD CLAMP WHEN PLAYING 7-INCH 45 RPM RECORDS.
5. Adjust the SPEED control to the position corresponding to the record speed of the records you are playing.
6. Momentarily turn the REJECT control clockwise.
 - a. The bottom record will now drop to the turntable, the pick-up arm will lift, swing in, and drop to the turntable; record playing will now begin.
 - b. The REJECT control may be turned momentarily clockwise to reject a record before it has completely played. NOTE: Never touch the pick-up arm while the record changer is in a changing cycle.
7. At the conclusion of playing and as the last record is being repeated, lift the pick-up arm and move it to the right.
8. Turn the SPEED control clockwise to the OFF position. NOTE: This stops the turntable, but the motor will continue to run until turned off either with the "phono" control or "power" switch on the radio panel.
9. Turn the power switch on the radio panel "off".

TO UNLOAD RECORDS

1. Raise the RECORD CLAMP.
2. Lift the records straight up from the turntable. Do not apply pressure to the top record. Keep your thumbs free. NOTE: When removing 45 RPM records, if the two metal separator discs of the large spindle are seen protruding from the spindle, lift the spindle, with the records, from the turntable and turn the spindle shaft until the discs disappear inside the holder before removing records.



A. To play 7-inch small-hole records, press down on the RECORD SUPPORT RELEASE and move the RECORD SUPPORT to the extreme outward position. Rest the records on the ledge of the RECORD SUPPORT and on the off-set of the small spindle.



B. To play 10-inch records, press down on the RECORD SUPPORT RELEASE and move the RECORD SUPPORT to the middle position (1-1/2 inches in from the extreme outward position). Rest the records on the ledge of the RECORD SUPPORT and on the off-set of the small spindle.



C. To play 12-inch records, press down on the RECORD SUPPORT RELEASE and move the RECORD SUPPORT to the extreme inward position. Rest the records on the ledge of the RECORD SUPPORT and on the off-set of the small spindle.

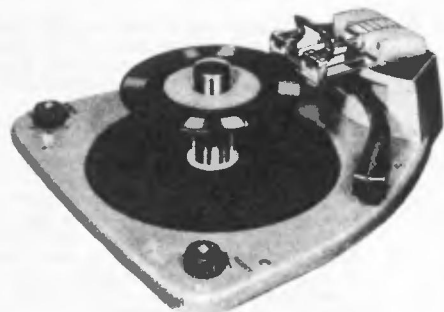

D. To play 7-inch large-hole records, press down on the RECORD SUPPORT RELEASE and move the RECORD SUPPORT to the extreme outward position. Rest the records on the off-set of the large spindle.

MANUAL OF 1950 MOST-OFTEN-NEEDED RADIO DIAGRAMS

MOTOROLA Record Changer Model RC-36, continued

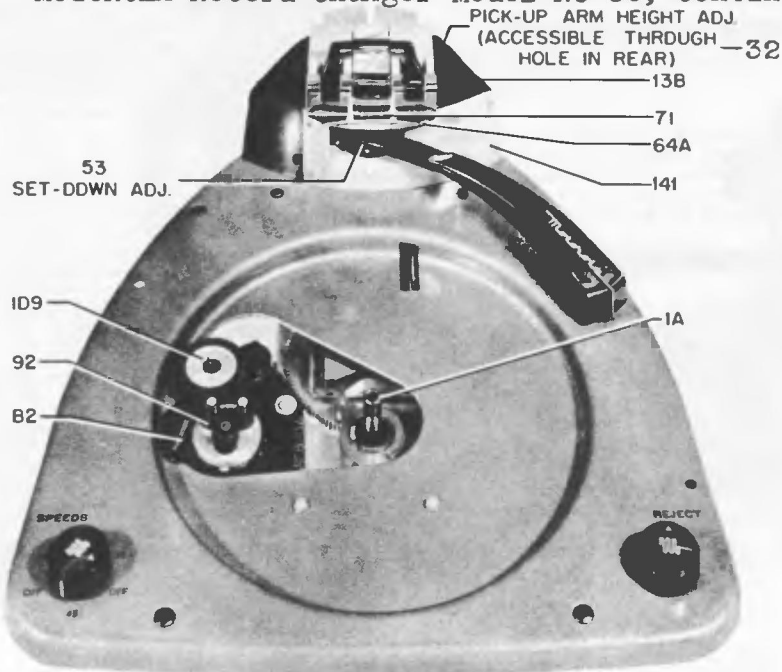

FIGURE 3. TOP VIEW OF RECORD CHANGER WITH TURNTABLE REMOVED

THEORY OF OPERATION

Refer to Figures 3, 4, 5, 6, 7 & 8 for location of the various parts described in this section. This will enable you to readily follow the operation of this unit.

The turntable is rim-driven. Power is transmitted to the turntable through an idler wheel (109) and a speed control turret (92). The speed control turret is operated by means of a 3-gear train, linking the turret to the speed change shaft assembly (87) which is manually operated by the speed control knob on the record changer base. This control has six positions - 78, 45 & 33-1/3 RPM and three "off" positions - controlled by an ingenious six-point cam (87A). This cam permits easy selection of turntable speeds, yet prevents the speed control turret (92) from jamming idler wheel (109) against turntable and causing flat-spots. The speed control can only be moved clockwise from a playing speed position, but may be moved counterclockwise or clockwise, one position, from an OFF position.

During a playing of a record, only the motor assembly (82) and turntable (119) are in operation. Balance of the mechanism is inoperative until the change cycle starts.

THE CHANGE CYCLE

The change cycle may be initiated in two ways - by means of the pick-up arm entering the cut-off grooves in the record or by manual operation of the reject knob. Power for the change cycle is obtained from the turntable.

Prior to a change cycle and while the turntable revolves, the weighted end of the drive clutch lever (118) is resting on the trip lever (21A). When the pick-up arm needle finishes playing a record and enters the cut-off groove, the trip arm (36A), attached to pick-up arm shaft (33), pushes the trip flag bracket (21B) - or when the changer's "reject" control is turned, the reject arm (4), acting through the reject rod (134), pushes the trip flag bracket (21B). This action releases trip lever arm (21C) allowing the trip lever spring (22) to pull the trip lever (21A) away from the drive clutch lever (118), causing the weighted end (118A) of the drive clutch lever (118) to lower and, consequently, the drive dog (118B) of the drive clutch lever contacts the drive screw (120) on the turntable and the change cycle begins.

When the drive clutch lever (118) engages the drive screw (120) and as the turntable continues to revolve, this revolving action causes the cycle gear (9) to turn through the drive gear (117). As the cycle gear revolves, its roller (9A) moves the slide channel (21) back and in doing so, the pick-up arm shaft (33) rides up on the incline (21D) of the slide channel, raising the pick-up arm. As the slide channel (21) continues its backward motion, the clutch fingers (21F) will engage the set-down arm assembly (36) to swing the pick-up arm in a direction away from the spindle. At the extreme backward travel of the slide channel (21) the push-off lever (60C), which rides in the slot (21E) of the slide channel, is actuated and this in turn, through the push-off link (72) moves the record push-off lever (71) pushing the lower record off the record support

MANUAL OF 1950 MOST-OFTEN-NEEDED RADIO DIAGRAMS

MOTOROLA Record Changer Model RC-36, continued

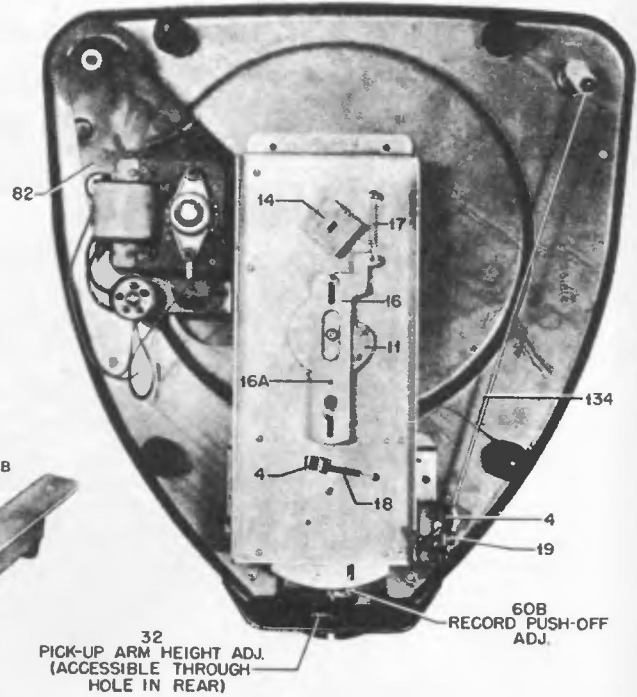
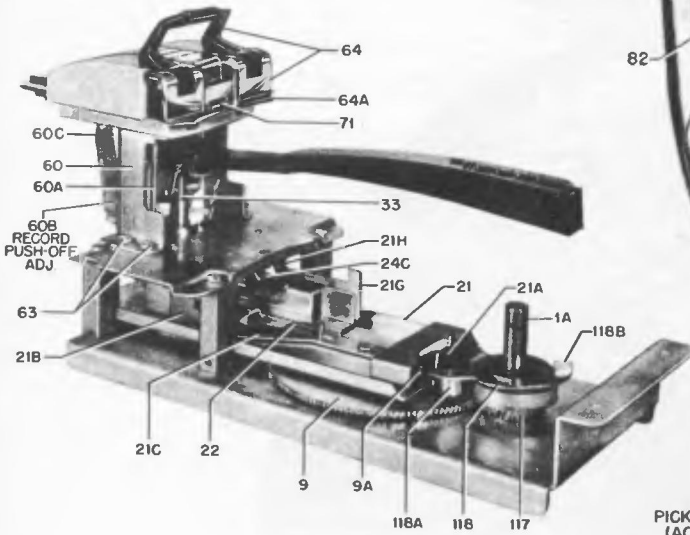

FIGURE 5. VIEW OF RECORD CHANGER WITH BASE & MOTOR ASSEMBLY REMOVED

FIGURE 4. BOTTOM VIEW OF RECORD CHANGER

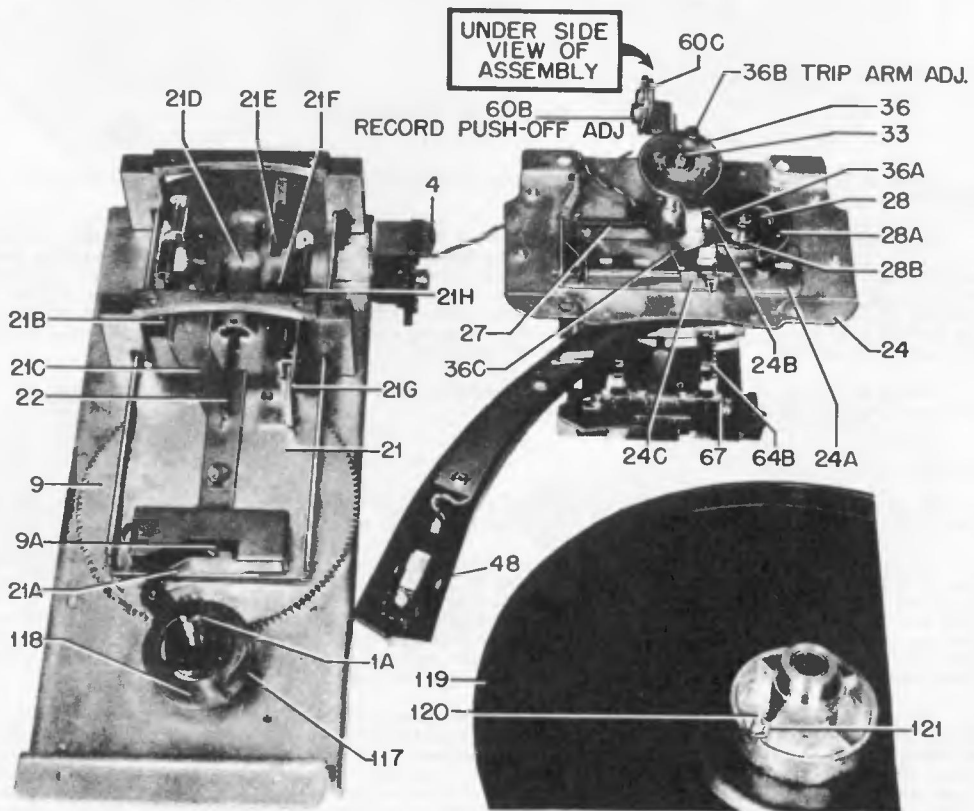

FIGURE 6. DISASSEMBLED VIEW OF RECORD CHANGER MECHANISM

MANUAL OF 1950 MOST-OFTEN-NEEDED RADIO DIAGRAMS

MOTOROLA Record Changer Model RC-36, continued

(64A) thus permitting it to drop to the turntable. At this same time, the restoring lever (21G) lowers the set-down flag (24C) (which will index the pick-up arm when the slide channel makes its forward motion) also the trip slide cocking stud (6) engages the trip arm (21C) with the trip flag (21B) to set it for the next cycle and to prevent re-cycling when the slide channel completes its cycle. At this point one-half of the change cycle is completed.

The cycle gear (9) will continue to rotate until it completes one revolution. As it continues to revolve, the slide channel (21) will move forward and the clutch fingers (21F) that are still engaging the set-down arm assembly (36) will now swing the pick-up arm back toward the record spindle until the set-down arm (36C) contacts the set-down flag (24C); this controls the pick-up arm set-down point. While the arm is being held over the set-down point by (24C), continued rotation of the cycle gear (9) makes the pick-up arm shaft (33) ride down the incline (21D), lowering the pick-up arm onto the record.

As the slide channel (21) approaches the end of the cycle (fully forward position) the set-down flag (24C) is moved out of the way by the restoring lever (21H) to give the pick-up arm complete freedom of movement during playing of the records.

When the slide channel moves fully forward, the drive clutch lever (118) rides up the trip lever incline (21A) and disengages the drive clutch lever dog (118B) from the drive dog screw (120) in the turntable, thus ending the cycle.

PICK-UP ARM SET-DOWN POINT

The point at which the pick-up arm drops to the turntable for either 7-inch, 10-inch or 12-inch records is determined by the position of the set-down flag (24C).

When the record support assembly (64) is adjusted for a specific size record, the movement of the record support causes rotation of the gear and pinion shaft assembly (60A) through the rack gear (64B) on the record support. Since the gear and pinion shaft assembly (60A) engages the set-down gear (28B) and the set-down cam (28A) is attached to the set-down gear, any movement of the record support will cause the set-down cam to turn. The set-down cam stud (24B), on the slide plate and spring assembly (24A), rides with the set-down cam due to the tension of the slide plate spring (27); therefore, any action of the set-down cam will affect the position of the set-down flag (24C).

45 RPM RECORD DROP

The 45 RPM spindle shaft, when dropped in the turntable center hole, fits into the slot in the timing stop (14).

When the change cycle begins and the slide channel (21) is making its backward movement, the reject plate (16) moves forward due to the eccentric form of the drop cam (11) riding on roller (16A) and the tension of the spring (17), pulls the reject plate (16) forward until it contacts timing stop (14), preventing it from rotating. Since the turntable with the 45 RPM spindle continues to rotate and the timing stop (14) and spindle shaft (153) remain stationary, the two pinion gears (155) in the upper section of the spindle rotate around the spindle shaft (153) gear. The eccentric extending from the upper end of the two pinion gears (155) runs in a slot in the molded record supports to produce the necessary action which causes the supports to move in against the tension of spring (156). As the plastic record supports recede, the separator discs mounted above each record support separate the lower record of the stack and support the remaining stack while the lower record drops to the turntable. With continued rotation of the spindle the record supports, due to the action of spring (156), will move out to support the record stack, while the separator discs recede into the spindle.

When the slide channel (21) is making its forward movement, the reject plate (16) moves back releasing the timing stop (14) allowing the timing stop and the spindle shaft to revolve for the playing of the record.

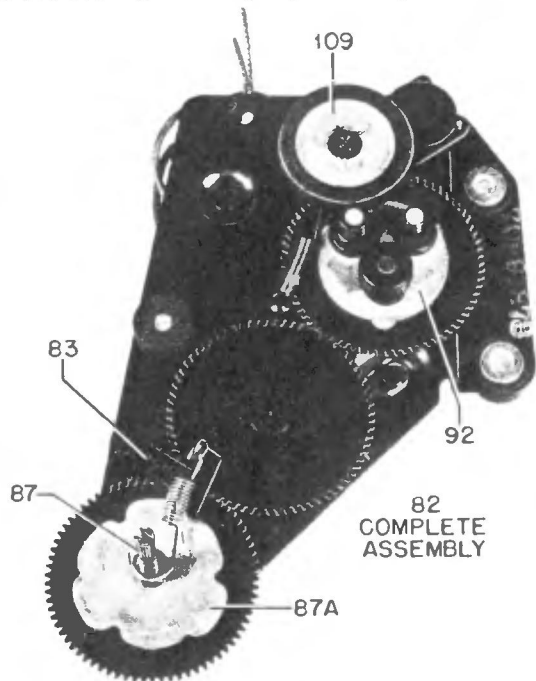
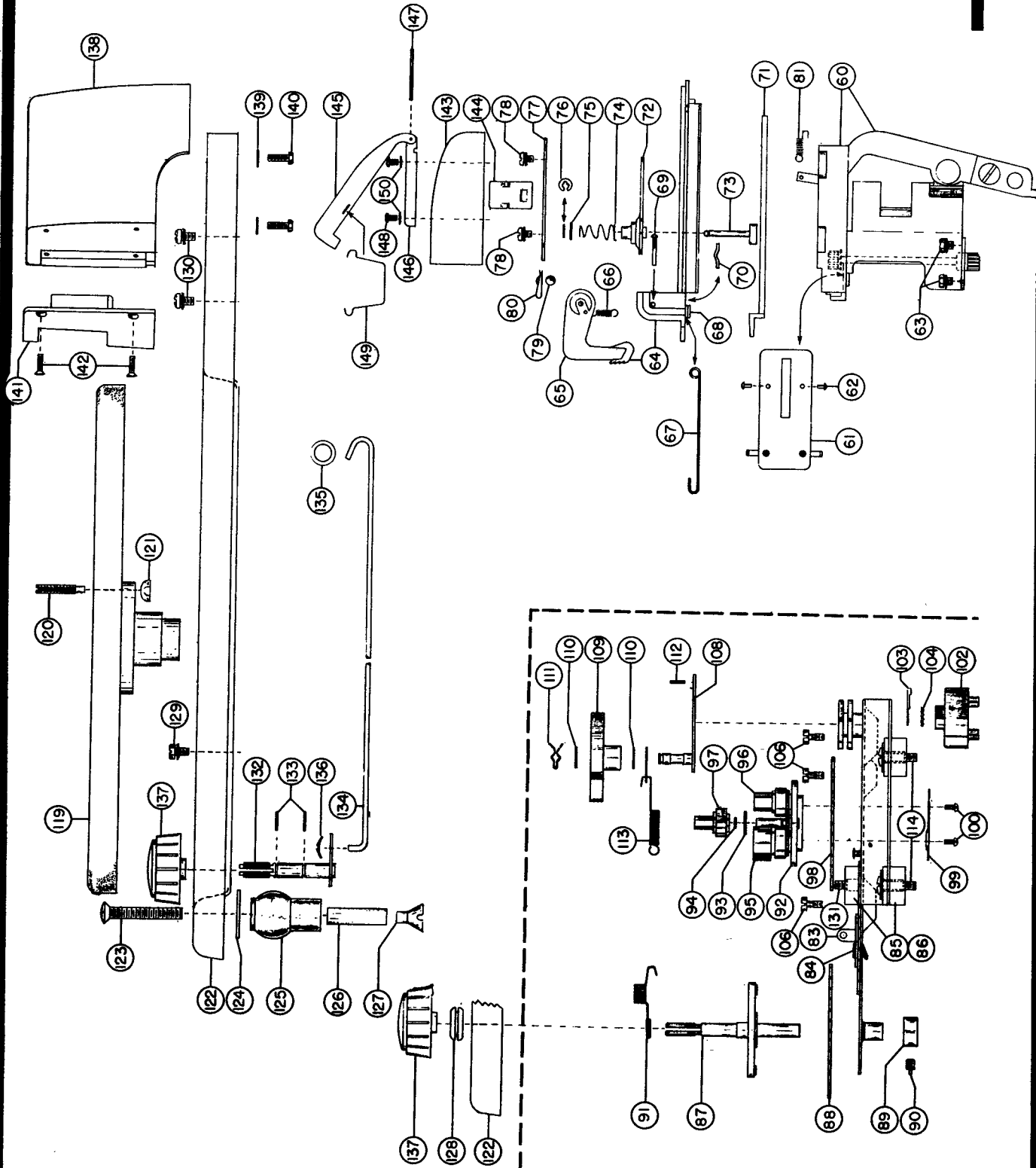

FIGURE 7. MOTOR & SPEED CHANGING ASSEMBLY

MANUAL OF 1950 MOST-OFTEN-NEEDED RADIO DIAGRAMS

MOTOROLA Record Changer Model RC-36, continued



MANUAL OF 1950 MOST-OFTEN-NEEDED RADIO DIAGRAMS

MOTOROLA Record Changer Model RC-36, continued

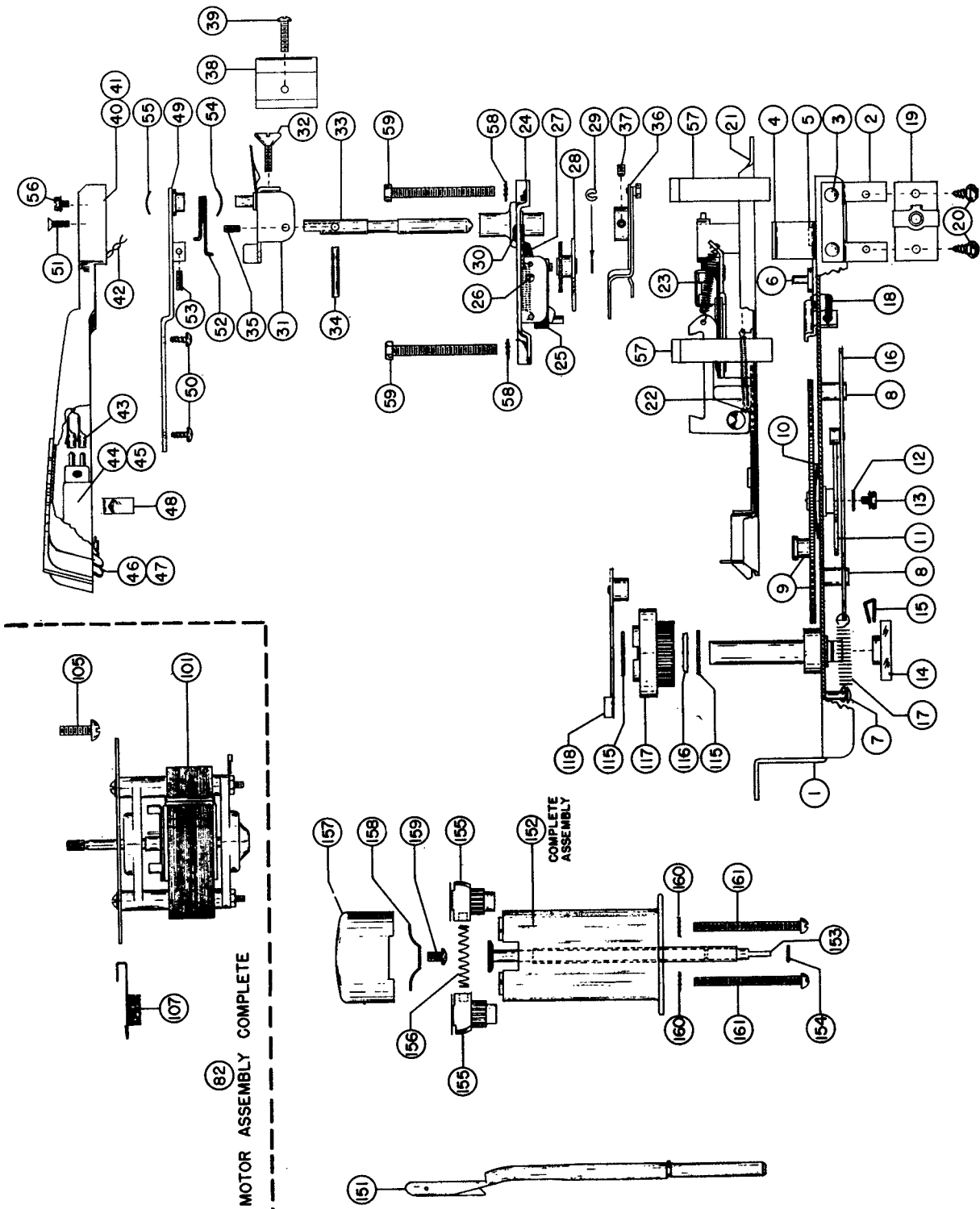

FIGURE 8. RECORD CHANGER REPLACEABLE PARTS

This drawing continued from previous page.

MANUAL OF 1950 MOST-OFTEN-NEEDED RADIO DIAGRAMS

MOTOROLA Record Changer Model RC-36, continued ADJUSTMENTS

NEEDLE SET-DOWN ADJUSTMENT

A template, (Motorola Part No. 54B792330) furnished with the record changer, is required to index the needle to the correct set-down point after a needle or cartridge has been replaced. If a template is not available, you may improvise one as follows:

1. Set a compass to 3-5/16 inches and draw a circle on a piece of cardboard.
2. Punch out a 17/64 inch diameter hole at the exact center of the circle.

To index the needle to the correct set-down point:

1. Place the small diameter spindle in the turntable and the template over the spindle.
2. Move the record support to the 7-inch record playing position. NOTE: When the needle is set correctly for this position, the index will be automatically set for 10-inch and 12-inch records.
3. Rotate the turntable by hand and turn the reject control to start the change cycle. Watch the needle carefully. It must land on the curved line of the template.
4. If the needle does not land on the line, adjust the set-down setscrew (53) located on the pick-up arm (see Figure 11). Turn the setscrew clockwise to move the pick-up arm in a direction towards the spindle, or turn the setscrew counterclockwise to move the pick-up arm in a direction away from the spindle. IMPORTANT: Turn the screw very slightly and repeat step 3. Repeat this procedure until the needle lands exactly on the curved line.

PICK-UP ARM HEIGHT ADJUSTMENT

If the pick-up arm strikes the bottom record of a stack of records resting on the 45 RPM spindle or the pick-up arm does not rise sufficiently to clear a 1-inch stack of records after they have dropped to the turntable, proceed as follows:

1. Remove the cabinet back or remove the record changer from the cabinet, as required, to gain access to the rear of the record changer.
2. The height adjustment screw (32) is accessible through a hole in the rear of the record support housing (138) (see Figure 3).
3. If insufficient clearance is noted, turn the height adjustment screw (32) clockwise to raise the arm, or counterclockwise to lower the arm, as required.

PUSH-OFF LEVER ADJUSTMENT

If a record fails to drop to the turntable, check the position of the record push-off lever (71) on the record support during a change cycle; it should protrude a minimum of 1/32 inch from the record support during the record dropping portion of change cycle. If adjustment is required, proceed as follows:

1. Remove the cabinet back or remove the record changer from the cabinet, as required, to gain access to the rear of the record changer.
2. Turn the reject knob to place changer in cycle and rotate turntable by hand until record push-off lever (71) is at its point of maximum forward travel.
3. Turn the push-off adjustment screw (60B) until push-off lever (71) protrudes 1/32 inch beyond lip (64A) of record support.

TURNTABLE DRIVE PIN ADJUSTMENT

If a "clicking" noise is heard while a record is playing, the drive dog adjusting screw (120) on the bottom of the turntable is touching the drive dog (118B). To remedy:

1. Remove the turntable. NOTE: Do not remove the drive clutch lever (118); also do not lose the bearing washer (115).
2. Loosen the hex nut (121) and turn the drive dog adjusting screw (120) counterclockwise to bring the screw further away from the drive dog. CAUTION: Do not turn the screw too much, since the screw will not engage the drive dog and, as a consequence, the changer will fail to cycle.
3. Tighten the hex nut (121).

TRIP ARM ADJUSTMENT

If the mechanism does not trip after playing a record or trips before a record has completed its play, the set-down arm (36) requires adjustment.

1. Readjust the needle set-down setscrew (53) (see paragraph on NEEDLE SET-DOWN ADJUSTMENT).
2. If adjusting the setscrew in step 1 does not correct the fault, remove the cabinet back or remove the record changer from the cabinet, as required, to gain access to the rear of the record changer.
3. Turn the set-down adjustment screw (53) until the end of the setscrew is even with the pick-up arm.
4. Adjust the trip arm adjustment stud (36B) (this is an eccentric stud) sufficiently so that mechanism trips correctly.
5. Readjust the needle set-down setscrew (53) (see paragraph on NEEDLE SET-DOWN ADJUSTMENT).

MANUAL OF 1950 MOST-OFTEN-NEEDED RADIO DIAGRAMS

Motorola Record Changer Model RC-36, continued PARTS REMOVAL AND REPLACEMENT

NEEDLE REPLACEMENT

Use only a Motorola needle; do not use any other needle, as damage to the records or crystal cartridge will result. **IMPORTANT:** After needle is replaced, check the set-down point as outlined in **NEEDLE SET-DOWN ADJUSTMENT**.

Two types of needles and crystal cartridges are being used. Look at your needle and cartridge!

IMPORTANT: The needle should be held in the cartridge perpendicular to the surface of the turntable.

1. If the needle is secured to the cartridge with a small, round knurled nut (see Figure 9), loosen the nut and remove the needle from the cartridge. Replace with Motorola needle, Part No. 59K691908. Insert the replacement needle in the cartridge needle receptacle and tighten the knurled nut.
2. If the needle is not held in place with a knurled nut, merely pull the needle from the cartridge using your fingers or pliers (see Figure 10). Replace with Motorola needle, Part No. 59K691909. The replacement needle is partly encased in a small guard to protect the needle point; push the needle into the cartridge needle receptacle and remove the guard. Friction will hold the needle in position.



FIGURE 9.



FIGURE 10.

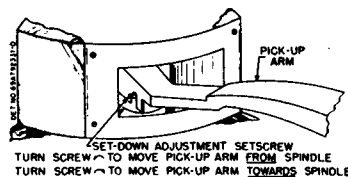

FIGURE 11.

CARTRIDGE REPLACEMENT

Two types of cartridges are being used, they are interchangeable. To remove the cartridge, merely remove the cartridge retainer clip (48) and disconnect the pick-up leads. **IMPORTANT:** After cartridge is replaced, check the needle set-down point as outlined in **NEEDLE SET-DOWN ADJUSTMENT** paragraph.

TO REMOVE THE TURNTABLE

1. Remove the turntable retaining clip.
2. Lift the turntable straight up from the base plate. Be sure the bearing (116) and bearing washer (115) do not get lost or dirty.
3. When replacing the turntable, it will be necessary to center the drive clutch lever (118) and bearing washer (115) to allow proper seating of the turntable over the spindle post.
4. Replace the turntable retaining clip.

TO REPLACE THE DRIVE CLUTCH LEVER

1. Place the changer mechanism in the rest position (slide channel (21) in full forward position) with the trip flag bracket (21B) engaged in the trip lever arm (21C).
2. Place the drive clutch lever (118) in position with the weighted end (118A) of the drive dog resting on the trip lever (21A).

TO REMOVE THE DRIVE GEAR

1. Remove the turntable and drive clutch lever (118).
2. Lift the drive gear (117) straight up from the spindle post.
3. When replacing the drive gear (117) it is important that the changer be timed correctly. To time, position cycle gear so that cycle gear roller (9A) is directly in line with the spindle post (1A) and pull the trip lever (21A) forward so that trip flag (21B) falls in and locks it in position. Now place the drive clutch lever (118) in position on drive gear (117) and mesh the gears so that weighted end of clutch lever (118) rests on the lowest edge of the trip lever (21A) incline. Check the timing by playing a stack of 45 RPM records. If a record of the stack fails to drop during a cycle, move the drive gear (117) one "tooth" and play another stack of records to again check the timing.

TO REMOVE THE MOTOR ASSEMBLY

1. Disconnect the power lead.
2. Remove one machine screw (131) from the bottom of the record changer securing the motor assembly to the base plate.
3. Remove the turntable from the record changer.
4. Remove the two machine screws (114) securing the motor assembly to the changer mechanism.
5. Remove the speed control knob.

MANUAL OF 1950 MOST-OFTEN-NEEDED RADIO DIAGRAMS

MOTOROLA Record Changer Model RC-36, continued

PICK-UP ARM MOUNTING PLATE ASSEMBLY REPLACEMENT

Should it ever become necessary to remove the pick-up arm mounting plate assembly (24), the following precautions should be observed when replacing the assembly.

1. Be sure that the hole in the set-down cam (28A) lines up with the hole in the mounting plate and that the set-down cam stud (24B) on the set-down flag (24C) is on the outside of the cam.
2. Be sure that the set-down flag (24C) is in a position so that it can be actuated by the restoring lever (21G).
3. The record support must be in the 12-inch playing position when replaced.

TO REMOVE THE SLIDE HINGE AND SLIDE BRACKET

1. Slide hinge (145) is secured with a spring clip (149). To unlatch the slide hinge: Place a folded piece of paper on both sides of the slide hinge, between the slide hinge and the slide cover (143) and pull the paper forward, simultaneously pulling the slide hinge upwards. See Figure 12.
2. Four machine screws secure the slide bracket (146) to the record support and slide cover (143).

SERVICE HINTS

STANDARD OR 33 RPM RECORDS FAIL TO DROP

1. Adjust the push-off lever (71), or -
2. Record center-hole binding on spindle. Ream out with pencil.

45 RPM RECORDS FAIL TO DROP

1. Drive gear (117) does not mesh with cycle gear (9) correctly.

PICK-UP ARM DOES NOT SET DOWN IN CORRECT POSITION

1. Adjust the set-down setscrew (53).

MECHANISM TRIPS BEFORE RECORD IS COMPLETED, OR DOES NOT TRIP AFTER RECORD IS COMPLETED

1. Adjust set-down setscrew (53) and the trip arm stud (36B).

CONTINUOUS CYCLING

1. Drive clutch lever (118) 180° out of phase; merely reverse the drive clutch lever's position on the drive gear (117), or -
2. Grease or dirt on trip flag bracket (21B), or -
3. Set-down flag (24C) not being actuated by restoring lever (21G), or -
4. Turntable bearing (116) or bearing washers (115) missing.

MECHANISM FAILS TO TRIP WHEN REJECT BUTTON IS TURNED

1. Reject rod (134) not connected, or -
2. Trip lever spring (22) weak or not connected.

MECHANISM SLOW IN STARTING

1. Bad motor, or -
2. Grease on idler wheel (109) or on speed control pulleys (95, 96 or 97), or -
3. Parts binding.

TURNTABLE DOES NOT REVOLVE

1. Check the power to the motor, or -
2. Remove the turntable and check to see if the motor shaft revolves, or -
3. Bad motor, or -
4. Grease on the idler wheel (109) or on speed control pulleys (95, 96 or 97), or -
5. Turntable not seated properly.

NEEDLE JUMPS GROOVES

1. Record changer not level, or -
2. Records dirty - clean with soap and water, or -
3. Needle not set correctly in the cartridge - it should be perpendicular to surface of the record.

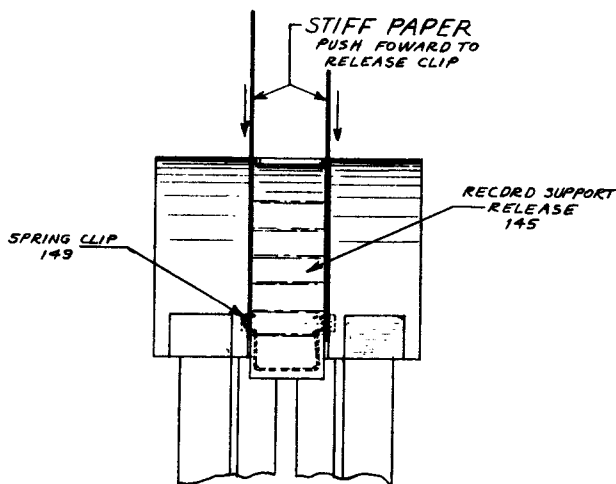

FIGURE 12. METHOD OF RELEASING CLIP ON RECORD SUPPORT RELEASE

MANUAL OF 1950 MOST-OFTEN-NEEDED RADIO DIAGRAMS

Motorola **AUTO** Radio

MODEL 309

Universal auto receiver for under dash mounting. Model 400 receiver is similar but uses miniature tubes as indicated in the chart below:

FUNCTION	309	400
R.F. Amplifier	6SK7GT	6BA6
Oscillator	6SA7GT	6BE6
I.F. Amplifier	6SK7GT	6BA6
Det.-Audio Amp.	6SQ7GT	6AV6
Power Amplifier	6V6GT	6AS5
Rectifier	6X5GT	6X4

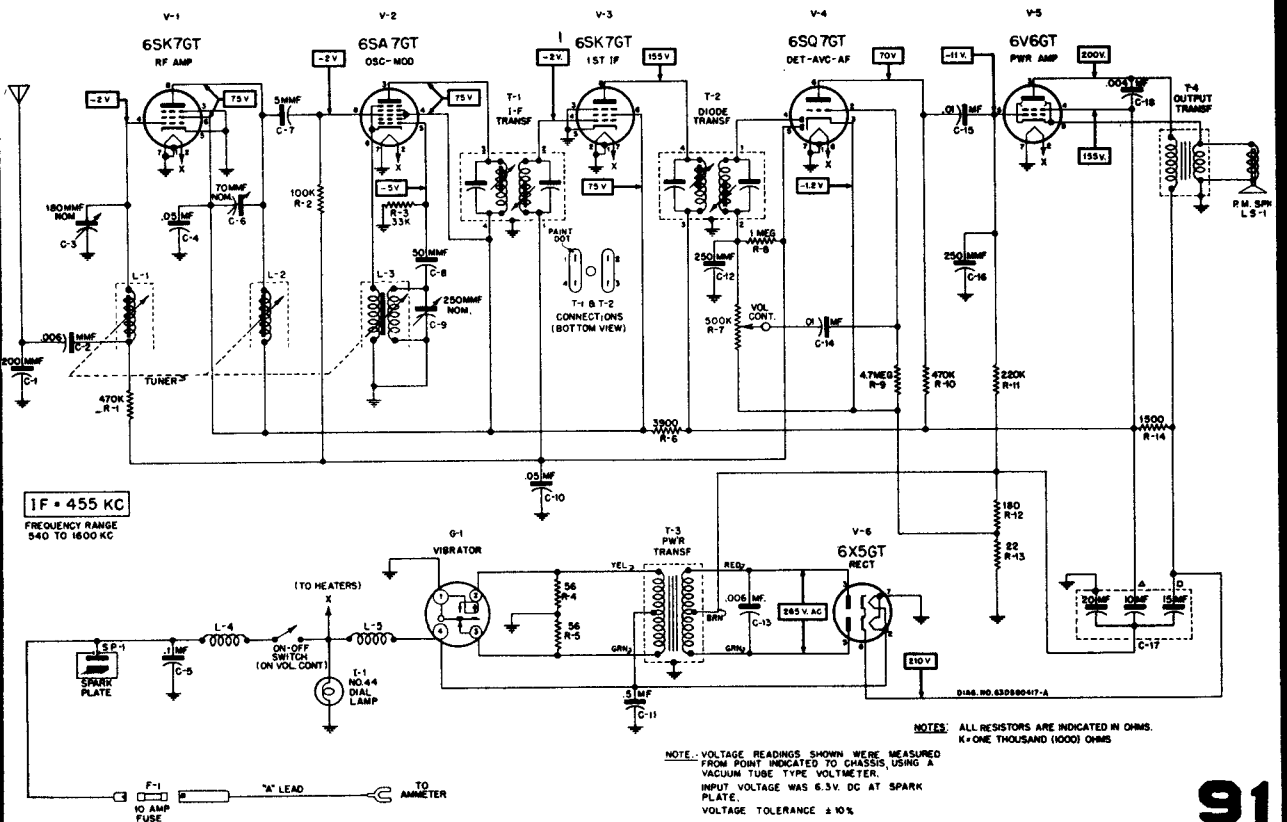
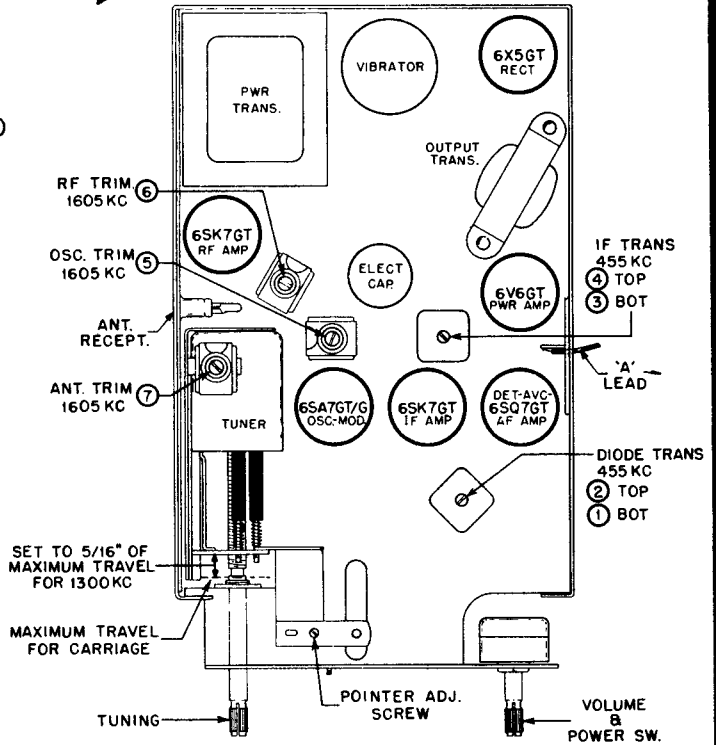
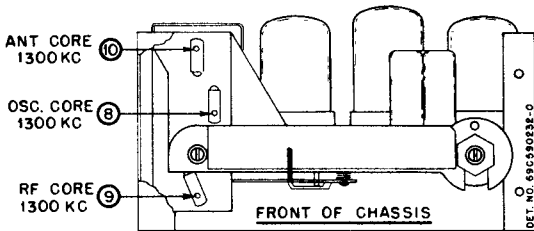

NOTES: ALL RESISTORS ARE INDICATED IN OHMS. K=ONE THOUSAND (1000) OHMS

NOTE: VOLTAGE READINGS SHOWN WERE MEASURED FROM POINT INDICATED TO CHASSIS, USING A VACUUM TUBE TYPE VOLTMETER. INPUT VOLTAGE WAS 6.3V. DC AT SPARK PLATE. VOLTAGE TOLERANCE ± 10%

MANUAL OF 1950 MOST-OFTEN-NEEDED RADIO DIAGRAMS

Motorola Auto Radio Model CT10 for 1950 Chevrolet. Model CT9 used in 1949 Chevrolet is very similar, but uses a 6V6GT power amplifier instead of a 6A4.

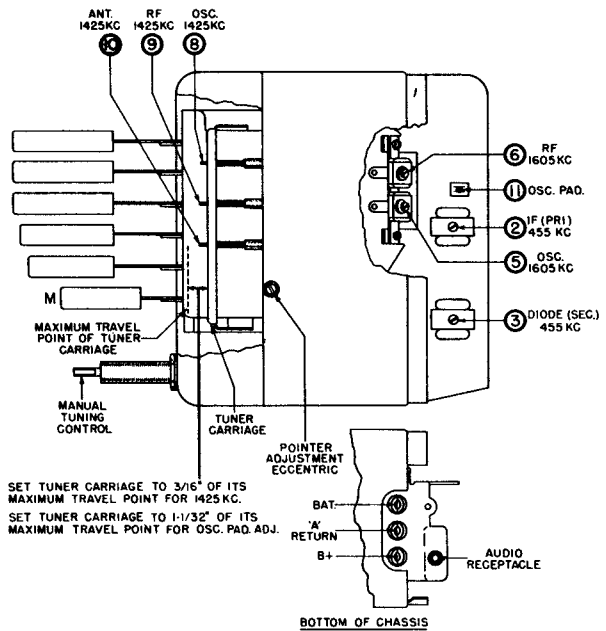
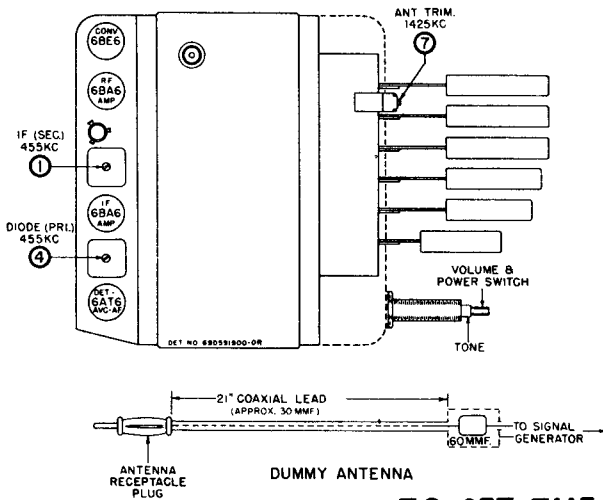

TO SET THE PUSH BUTTONS

1. Turn the radio ON and allow it to warm up for a few minutes.
2. Push the top button in as far as it will go and HOLD IT THAT WAY.
3. With the tuning knob, tune in the station you

desire to set up. Tune carefully until you are exactly on the station; tuning to either side of it will result in poor tone quality. Release button and knob after tuning-in the station.

4. Follow above steps 2 and 3 for the remaining four buttons.

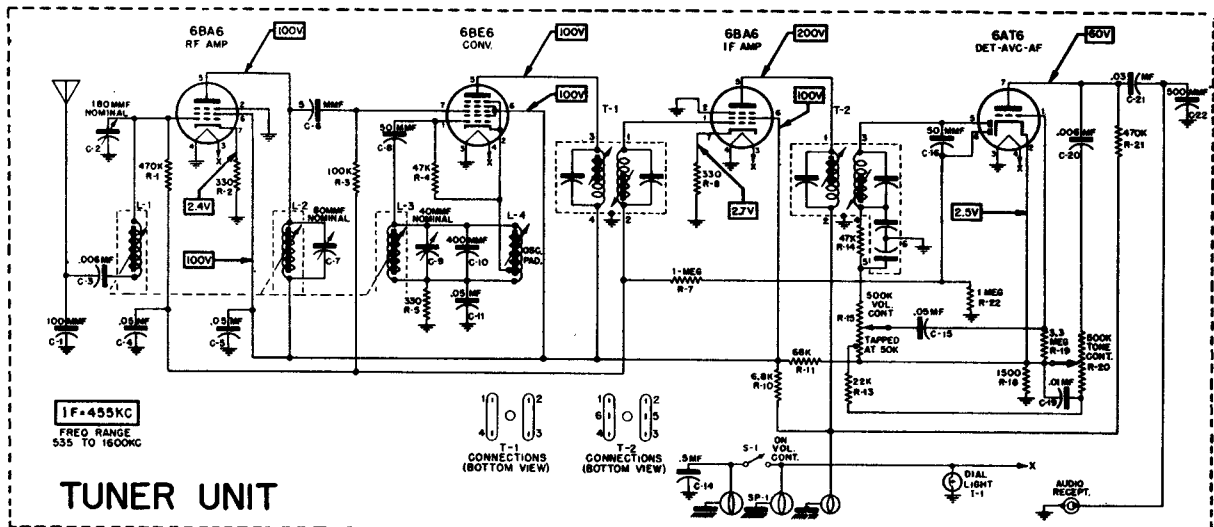

TUNER UNIT

TO CONVENIENT SOURCE OF BATTERY POWER

NOTE:- ALL RESISTORS ARE INDICATED IN OHMS, K=ONE THOUSAND (1000) OHMS. VOLTAGE READINGS SHOWN WERE MEASURED FROM POINT INDICATED TO CHASSIS, WITH A VTVM. NO SIGNAL WAS TUNED IN. INPUT VOLTAGE WAS 6.3VDC AT BATTERY RECEPTACLE VOLTAGE TOLERANCE $\pm 10\%$

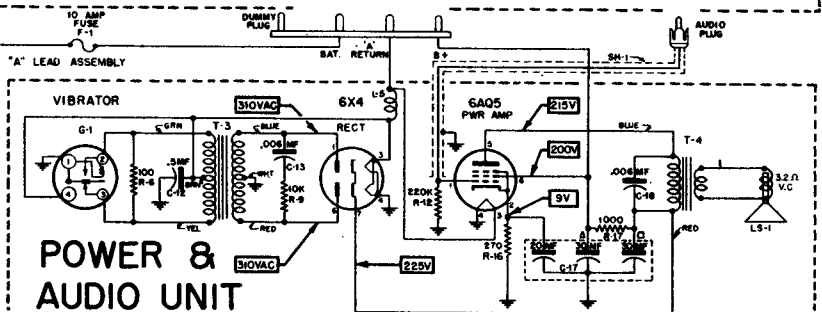

POWER & AUDIO UNIT

Motorola Inc.

MANUAL OF 1950 MOST-OFTEN-NEEDED RADIO DIAGRAMS

Motorola Inc.

**MODEL
409**

SENSITIVITY CONTROL. This control must be set to provide $2 \pm 1/2$ volts bias on the RF tubes before alignment is started. Measure this voltage between sensitivity control terminal and chassis.

For greatest accuracy, keep output of receiver at approximately 1 watt (1 watt = 1.79 volts on output meter) throughout alignment by reducing generator output (not receiver volume control) as stages are brought into alignment.

IF ALIGNMENT

A. Connect high side of signal generator through .1 mf capacitor to 6BE6 grid (pin #7) and the low side to chassis. Set generator to 455 Kc and peak adjustments (1, 2, 3 & 4), in this order, for maximum output.

B. Check alignment by repeating procedure.

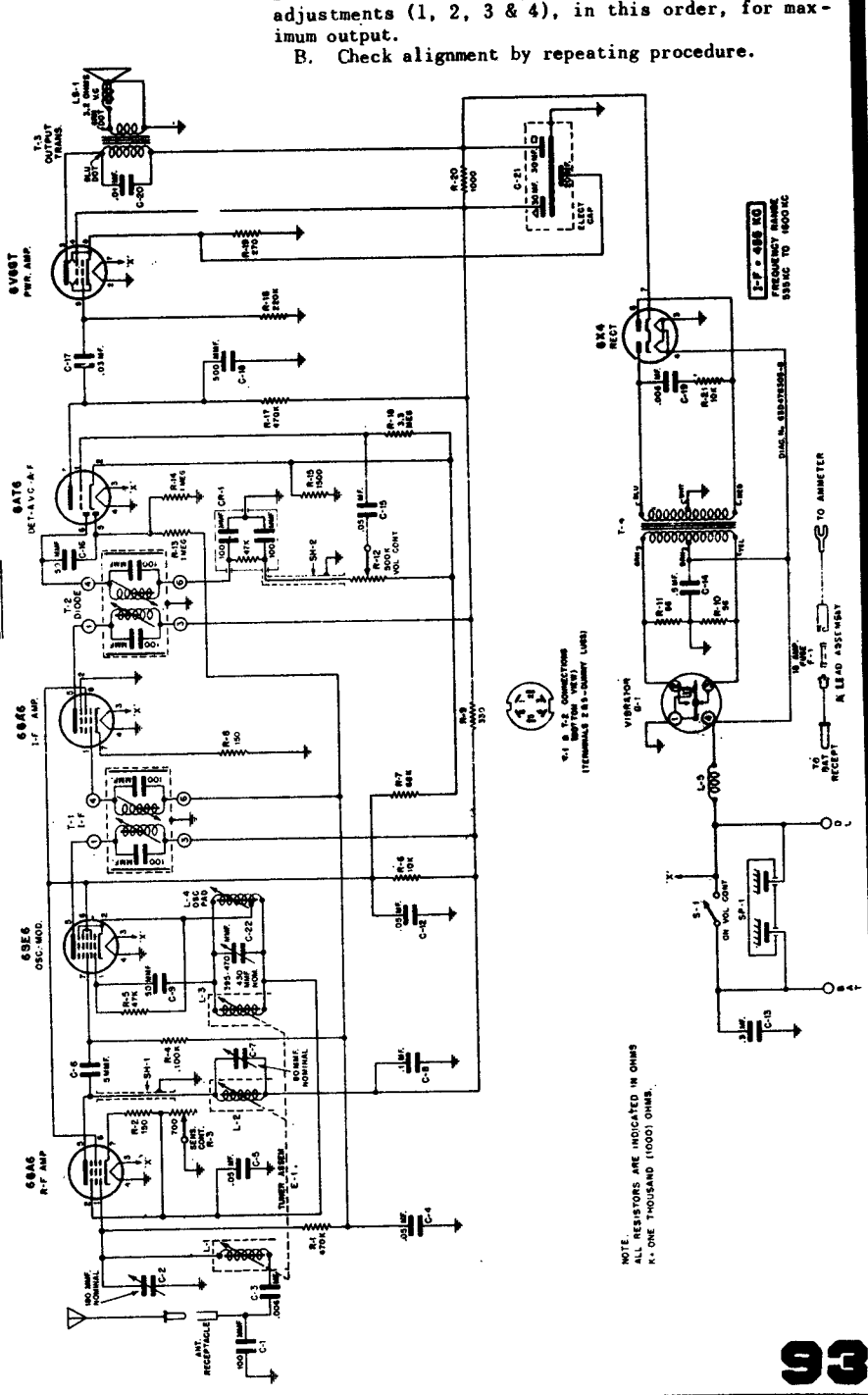
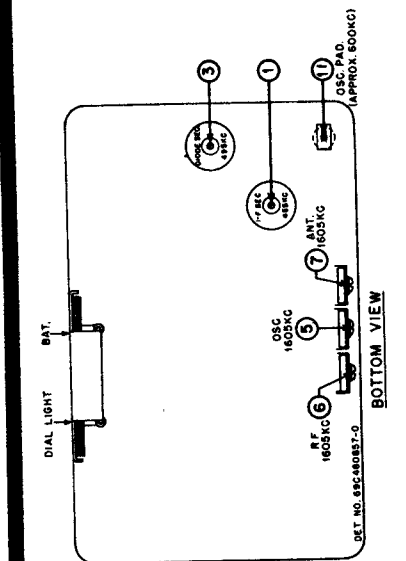
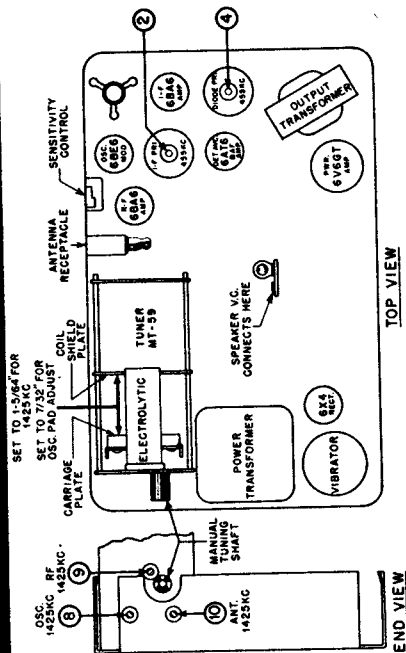

NOTE: RESISTORS ARE INDICATED IN OHMS
K: ONE THOUSAND (1000) OHMS.

MANUAL OF 1950 MOST-OFTEN-NEEDED RADIO DIAGRAMS

Motorola **AUTO** Radio

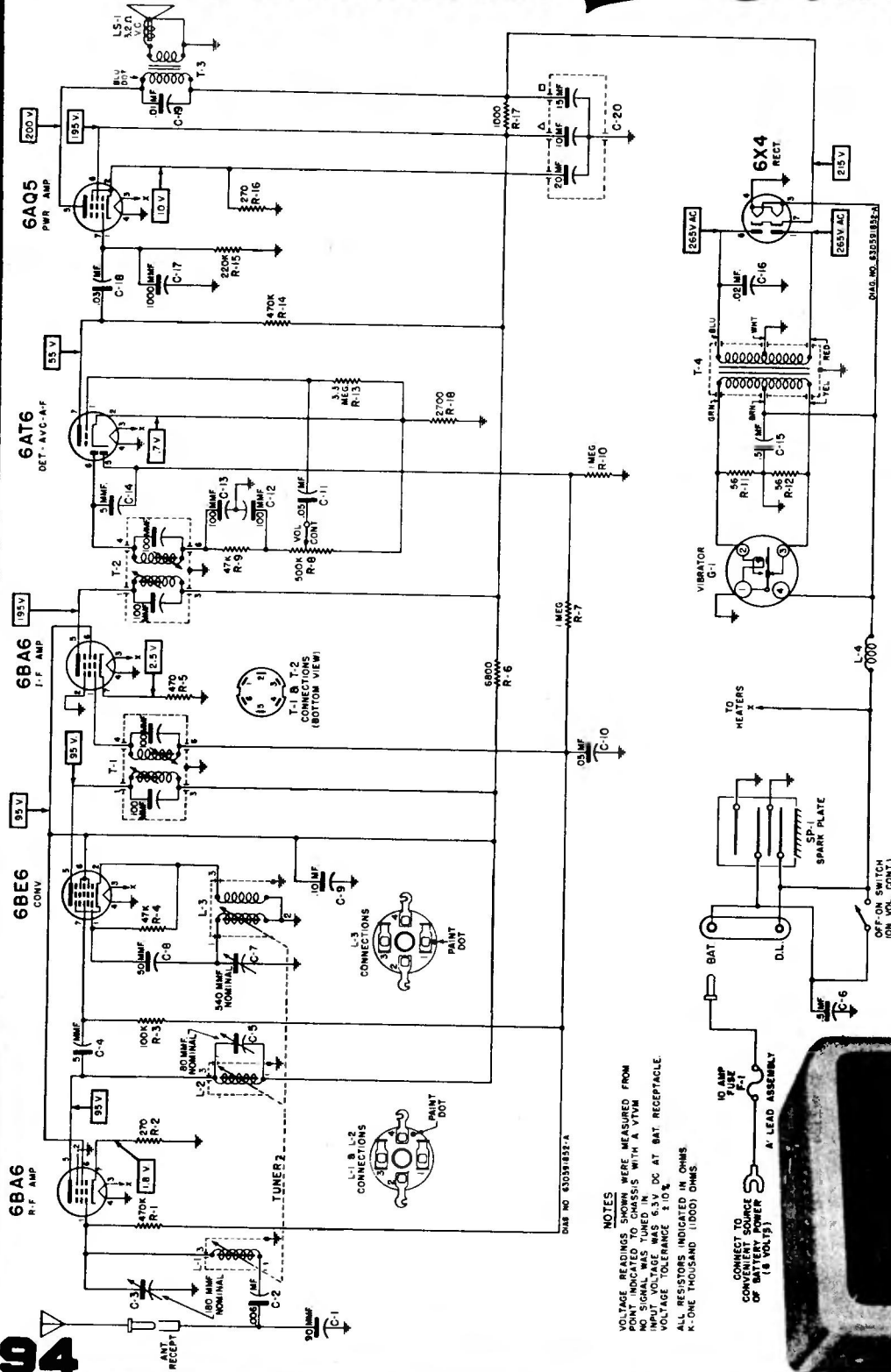

MODEL 500

I.F. • 455 KC

FREQUENCY RANGE - 535 TO 1600 KC

Compact automotive type superheterodyne receiver with self-contained speaker. Receiver is designed for installation in any car when used with appropriate Motorola control head.

NOTES
 VOLTAGE READINGS SHOWN WERE MEASURED FROM
 POINTS INDICATED WITH A VTVM
 NO SIGNAL WAS TUNED IN
 INPUT VOLTAGE WAS 6.3V DC AT BAT RECEPTACLE.
 VOLTAGE TOLERANCE ±10%
 ALL RESISTORS INDICATED IN OHMS
 K-ONE THOUSAND (1000) OHMS

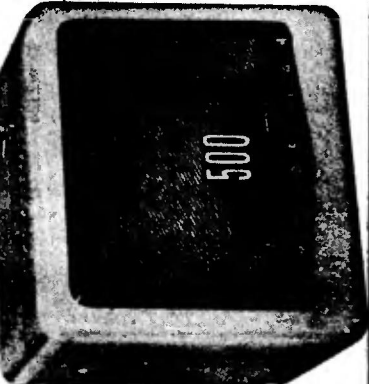

MANUAL OF 1950 MOST-OFTEN-NEEDED RADIO DIAGRAMS

Motorola **AUTO** Radio

MODEL
600

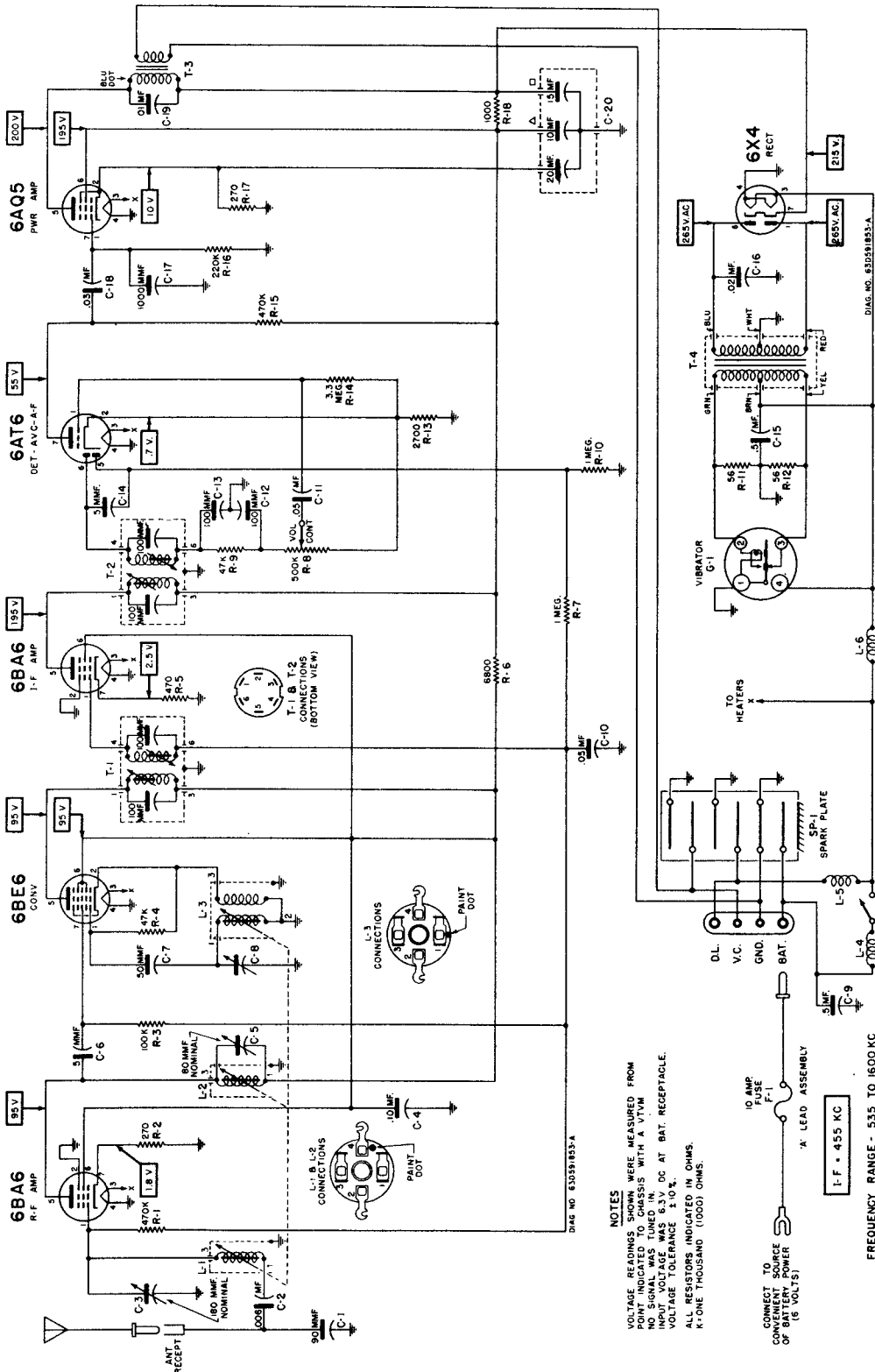

DIAG. NO. 630581853-A

NOTES
VOLTAGE READINGS SHOWN WERE MEASURED FROM POINT INDICATED TO CHASSIS WITH A VTVM
INPUT VOLTAGE WAS 6.3V DC AT BAT. RECEPTACLE.
VOLTAGE TOLERANCE ±10%.
ALL RESISTORS INDICATED IN OHMS.
K-ONE THOUSAND (1000) OHMS.

CONNECT TO POSITIVE OF BATTERY POWER (6 VOLTS)
10 AMP FUSE F-1
X: LEAD ASSEMBLY
L-F • 455 KC
FREQUENCY RANGE - 535 TO 1600 KC
OFF-ON SWITCH (ON VOL. CONT.)

TUBE COMPLEMENT

- 6BA6 - RF Amplifier
- 6BE6 - Converter
- 6BA6 - IF Amplifier
- 6AT6 - Det, AVC & AF Amp
- 6AQ5 - Power Amplifier
- 6X4 - Rectifier

POWER INPUT - 6.8 amps at 6.3 volts
POWER OUTPUT - 3.5 watts (max)

Motorola Inc.

Compact automotive type superheterodyne receiver designed for installation in any car when used with appropriate Motorola control head and speaker.

MANUAL OF 1950 MOST-OFTEN-NEEDED RADIO DIAGRAMS

ARVIN RADIOS — MODELS 341T

CHASSIS RE-274 4 TUBE AC-DC

MANUFACTURED BY NOBLITT-SPARKS INDUSTRIES, Inc., COLUMBUS, IND.

ALIGNMENT PROCEDURE

PRELIMINARY:

Output meter connection	Across loudspeaker voice coil
Output meter reading to indicate 200 milliwatts (standard output)	0.8 volts
Dummy antenna to be in series with signal generator output	See chart below
Connection of generator ground lead	Floating ground
Generator modulation	30% 400 cycles
Position of Volume Control	Fully clockwise
Position of pointer with variable fully closed	54 on dial

Position of Variable	Generator Frequency	Dummy Antenna	Generator Output Connection	Trimmers Adjuster	Trimmer Function	Approximate Sensitivity
Open	455 Kc	.05 uf	12SA7 Grid (Stator of C-1)	2 trimmers on top of T-3 **C-2	IF	3000 uv
1400 Kc	1400 Kc	.00005 uf	Antenna lug with Ant. Removed		Oscillator	360 uv

**Since the antenna section of the variable has no trimmer, the rotor of the variable should be rocked back and forth on both sides of 1400 Kc while adjusting the oscillator trimmer for maximum output. This is to obtain the combination of rotor and trimmer setting to give perfect tracking of the two sections of the variable condenser and consequently give maximum output.

Check sensitivity at 600 Kc. If weak, adjust antenna section plates for maximum output at 600 Kc. Tracking of the condenser at points other than 1400 Kc is accomplished by bending the outside plates on the variable condenser rotor, which are cut for this purpose. When bending plates to track the condenser at any given frequency, keep in mind the fact that this will affect the tracking at all frequencies below the point where the plates are bent. A tuning wand is very helpful in checking the tracking of this condenser, to indicate whether more or less capacity is needed.

The alignment procedure should be repeated stage by stage in the original order for greatest accuracy.

Always keep the output from the test oscillator at its lowest possible value to make the AVC action of the receiver ineffective.

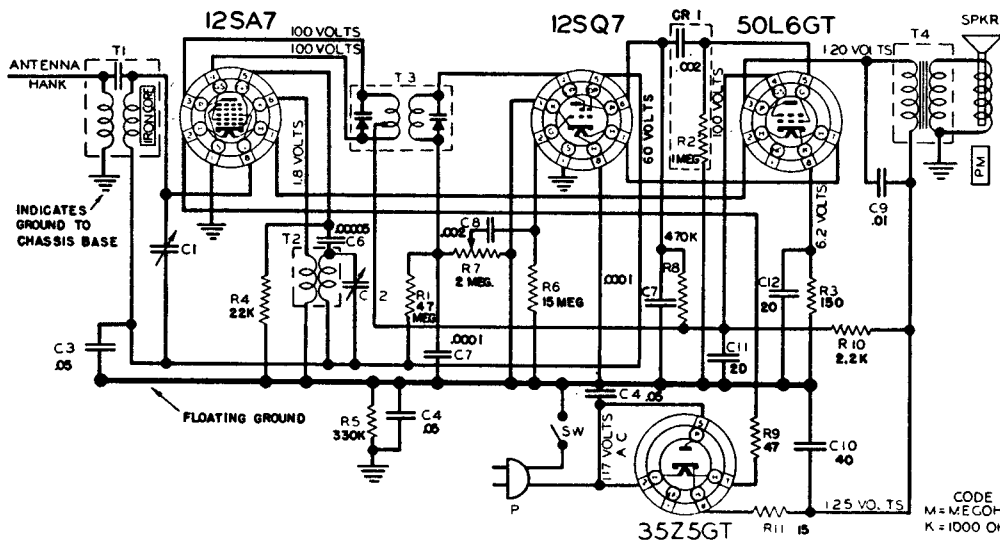
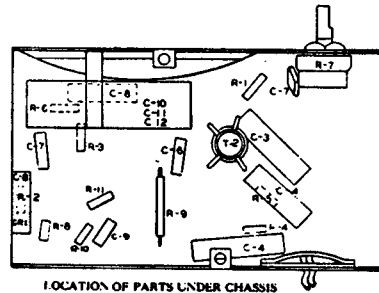
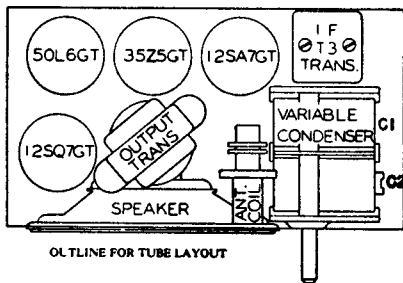

MANUAL OF 1950 MOST-OFTEN-NEEDED RADIO DIAGRAMS

ARVIN RADIOS, MODELS 360TFM AND 361TFM

CHASSIS RE-260, 6 TUBE AC-DC, AM-FM

MANUFACTURED BY NOBLITT-SPARKS INDUSTRIES, Inc., COLUMBUS, INDIANA

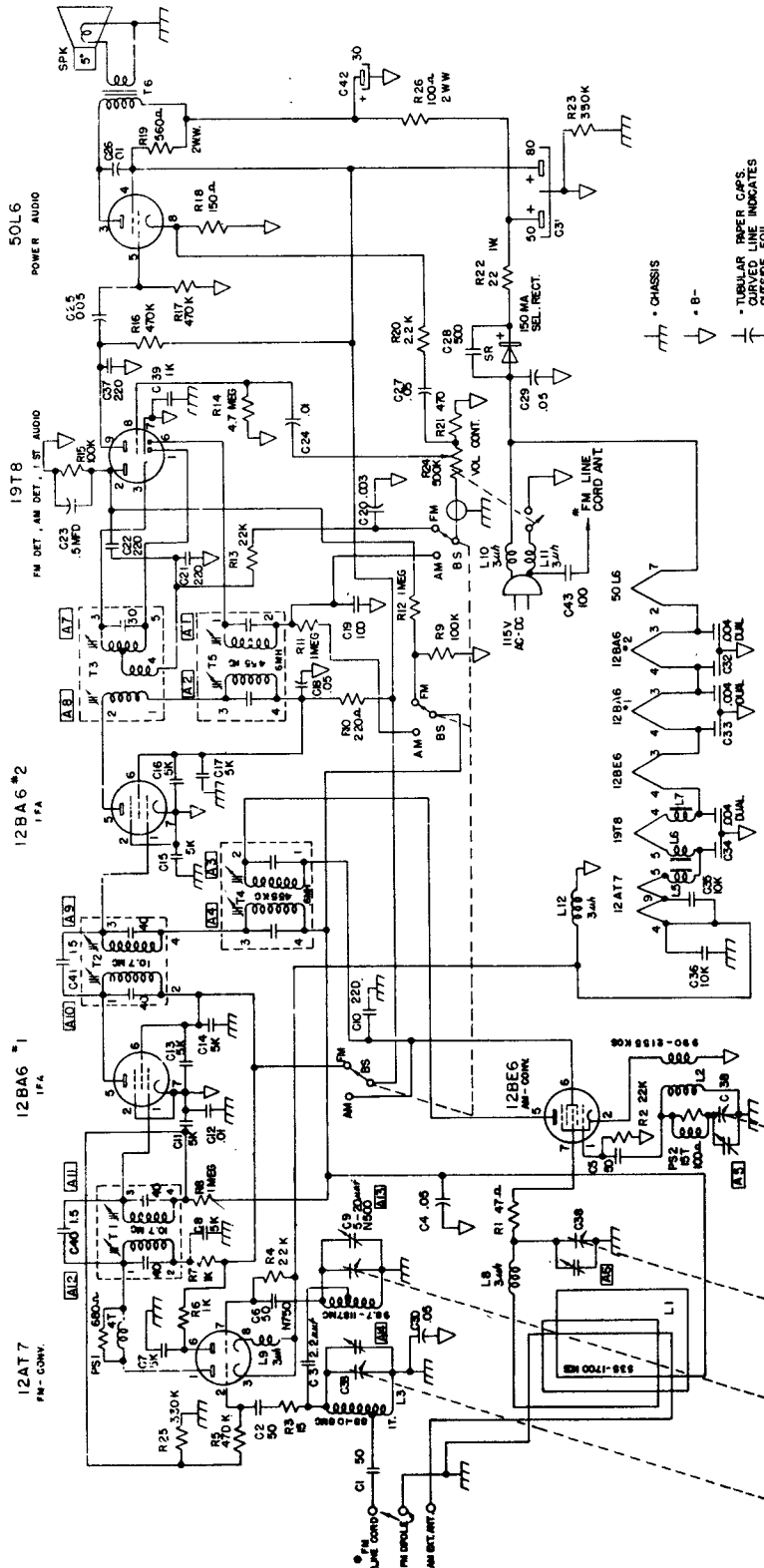

Alignment facts are given on page 98.

* CHASSIS

† TUBULAR PAPER CAPS. CURVED LINE INDICATES OUTSIDE FOIL.

APPROXIMATE VOLTAGE AND RESISTANCE MEASUREMENTS TUBE SOCKET LUGS TO FLOATING GROUND

TUBE	FUNCTION	BAND SW. POSITION	1	2	3	4	5	6	7	8	9	1	2	3	4	5	6	7	8	9
12AT7	FM Converter	FM	96	-1*	**	**	**	**	**	**	**	Inf.	1 meg.	0	0	50	-	22K	.2	20
12BE6	AM Converter	FM	**	0	46	46	46	46	46	46	46	22K	.5	50	36	36	36	36	36	36
12BA6	1st I-f Amp. (FM)	AM	-9	0	43	51	109	109	-1	0	0	22K	.5	50	56	56	56	56	56	56
12BA6	2nd I-f Amp. (AM-FM)	FM	-8	0	45	45	45	45	45	45	45	410K	0	90	50	50	50	50	50	50
12BA6	1st Audio Amp.	AM	**	0	45	45	45	45	45	45	45	522K	0	90	50	50	50	50	50	50
50L6	Out put	FM	0	48	118	98	0	0	AC	117	7	100K	0	70	80	80	80	80	80	80
		AM	0	47	120	110	0	0	AC	117	7.8	785K	0	70	80	80	80	80	80	80

All voltage readings not indicated otherwise are +DC.
 * Measure with vacuum tube voltmeter.
 ** These lugs are not used in this position of the band switch on different sets and with different types of meters.
 Inf - Infinite resistance or open circuit.
 † Resistance readings at these points will vary greatly.

MANUAL OF 1950 MOST-OFTEN-NEEDED RADIO DIAGRAMS

ARVIN RADIO Models 360TFM and 361TFM, Chassis RE-260

ALIGNMENT PROCEDURE

AM

1. Plug set into 117 V. power source, turn volume control full on and band switch to AM, (left).
2. Connect output meter across speaker voice coil.
3. Connect signal generator high side through .05 mfd. condenser to converter grid and generator ground lead to receiver floating ground. Open tuning condenser. Set signal generator to 1650 Kc. Tune trimmer A5 on oscillator section of tuning condenser for maximum output.
4. Close tuning condenser and set pointer at end mark of dial. Open tuning condenser. Connect signal generator to 1650 Kc. Tune trimmer A5 on oscillator section of tuning condenser for maximum output.
5. Set signal generator to 1400 Kc. Adjust tuning shaft until maximum output is obtained. Tune antenna trimmer A6 on tuning condenser for greatest output. Reset tuning shaft until output is again a maximum. Retune antenna trimmer. Repeat this cycle of operations at 1400 Kc until no further increase of output can be obtained. Keep generator output at a low value to prevent detuning by A. V. C. action.
6. Set signal generator to 600 Kc. Adjust tuning shaft for maximum output. Adjust tuning condenser plates for maximum output.
7. Check sensitivity at 1000 Kc. If sensitivity is too low, tuning condenser plates can be adjusted for tracking at this frequency. If this adjustment is made, tracking at 600 Kc must be readjusted.
8. Check coverage and calibration after alignment. Coverage should include 535 and 1650 Kc. Calibration should be such that pointer covers some part of calibration mark. If coverage and/or calibration are not correct, plates of tuning condenser can be adjusted. Calibration check points are 1400, 1000 600 and 540 Kc. If oscillator plates are adjusted, tracking of antenna section must be rechecked and corrected if necessary.
9. Check setting of trimmers on tuning condenser. Trimmer adjustments must not be extremely tight nor so loose as to be noisy or vibrate.
10. After alignment, check for noise due to condenser plates touching or pointer touching dial as tuning shaft is turned through the full tuning range.
11. The sensitivity of this set should be approximately 500 uv/m with 400 cycles, 30% modulation and 200 milliwatts, (.8 volt output).

FM

1. Turn band switch to FM, (right).
2. Connect (FM) I.F. generator to the second 12BA6 I.F. amp. grid, (lug #1) through the .01 uf mica dummy.

Connect oscilloscope across volume control. With 150 Kc deviation 10.7 on the I. F. generator and the same audio voltage used as horizontal sweep on the scope, adjust the ratio detector transformer slugs A7-A8 for the characteristic "S" curve (See Fig. 1), with maximum vertical height on the scope. After this adjustment the top slug of the ratio detector should not be moved during the rest of the alignment.

3. Connect I.F. generator to mixer grid through .01 mica dummy. Using 23 Kc deviation 10.7 Mc adjust 10.7 Mc I. F. transformer slugs A9, A10, A11 and A12 for maximum output. Maximum output may be indicated by maximum vertical height on the scope or maximum voltage on a standard output meter across the voice coil of the receiver. After the two I.F. transformers have been aligned the bottom slug A8 of the ratio detector should also be peaked. The characteristic "S" curve of the complete I.F. channel should be checked by applying a 10.7 Mc signal with 150 Kc deviation to the mixer grid and observing the "S" curve on the scope. It should not be very much different from that observed in step 2.

4. Connect R.F. (FM) generator (88 to 108 Mc) to the antenna terminals through the standard 300 ohm dummy (150 ohm in each side of generator leads). Use R.F. generator with 23 Kc deviation. With the variable condenser completely open and S.G. tuned to 108.5 Mc adjust oscillator trimmer A13 (small ceramic trimmer) for maximum reading on output meter.

Then tune receiver to low end of band (variable completely closed) and S.G. to 87.5 Mc. (If the receiver does not tune to this frequency the FM oscillator coil L4 will either have to be squeezed together or lengthened to cover the band, (squeezing lowers and lengthening raises the frequency). Any change in the coil will have to be compensated by the trimmer at the high end of the band.

5. With the same S.G. connections as per paragraph 4 tune S.G. and set to 105 Mc. Tune R.F. trimmer A14 for maximum output at the same time rock variable back and forth through the frequency. (Rocking is necessary because slight oscillator pulling causes erroneous maximum readings).

Tune S.G. and set the 90 Mc. Adjust R.F. coil L3 length for maximum output by squeezing or lengthening. Any change in the coil will have to be compensated at 105 Mc by the R.F. trimmer A14.

6. After steps 4 and 5 are finished check calibration and band coverage. Steps 4 and 5 may have to be repeated if set is off calibration. Band coverage should be 87.5 Mc to 108.5 Mc. Sensitivity should be approximately 200 uv at 105 Mc, 98 Mc and 90 Mc.

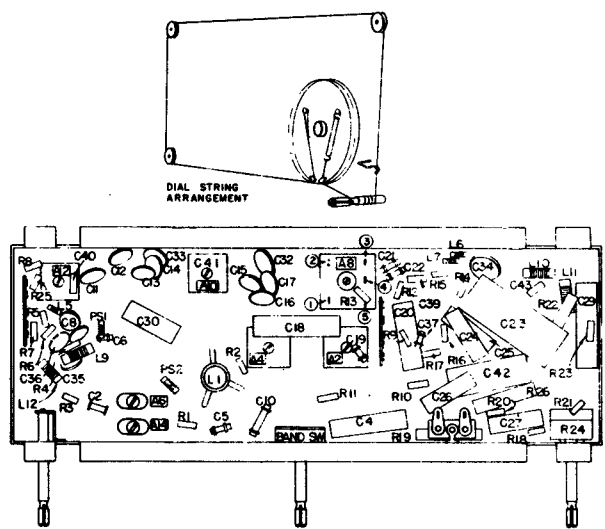
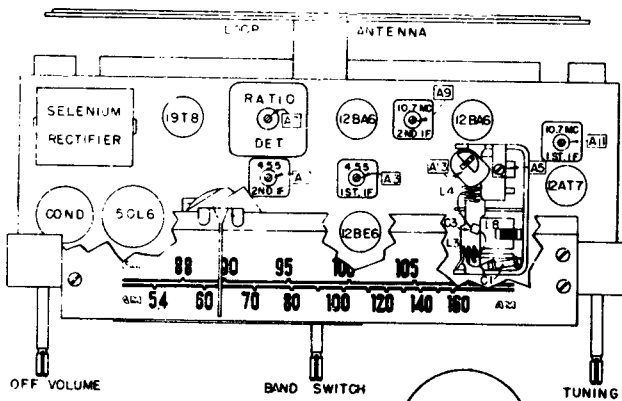

LOCATION OF PARTS AND TRIMMERS UNDER CHASSIS

FIG. 1.

MANUAL OF 1950 MOST-OFTEN-NEEDED RADIO DIAGRAMS

ARVIN RADIOS, MODELS 356T & 357T
 CHASSIS RE-273, 5 TUBE AC-DC
 NOBLITT-SPARKS INDUSTRIES, Inc.

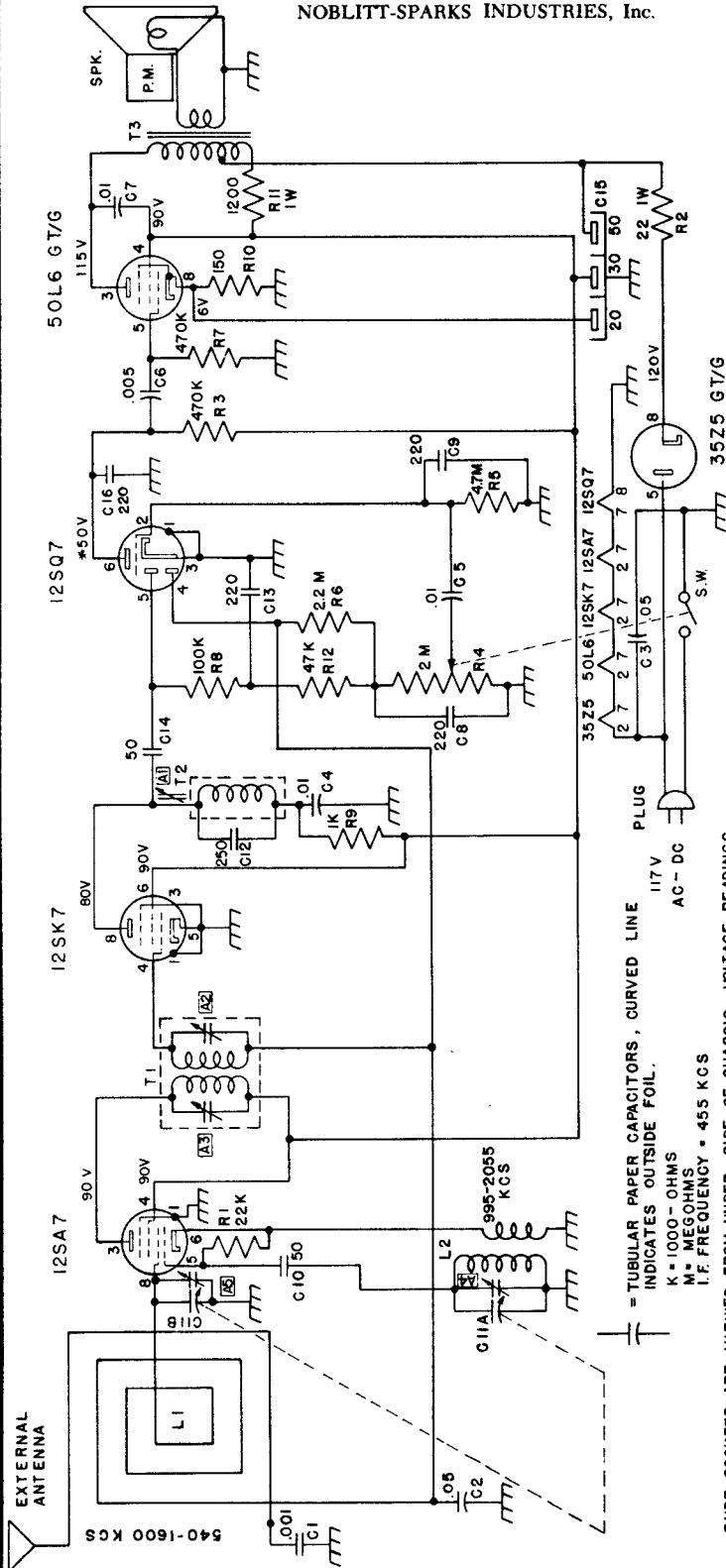

TUBE SOCKETS ARE VIEWED FROM UNDER SIDE OF CHASSIS. VOLTAGE READINGS SHOWN AT SOCKET PRONGS ARE TO CHASSIS AND ARE TAKEN WITH NO SIGNAL. A C LINE VOLTAGE AT 117 VOLTS.
 * MEASURED WITH VACUUM TUBE VOLTMETER. CAPACITY OF CONDENSERS LESS THAN .001 MF IS SHOWN IN MMF.

FREQUENCY RANGE
 Broadcast ----- 540-1600 kc
 IF ----- 455 kc

TUBES AND FUNCTIONS
 12SA7 ----- Mixer-oscillator
 12SK7 ----- IF amp.
 12SQ7 ----- DET-AVC AF Amp.
 50L6GT/G ----- Output
 35Z5GT/G ----- Rectifier

POWER SUPPLY
 105-125 Volts, AC-DC, 35 Watts

POWER OUTPUT
 Undistorted ----- 1.2 Watts
 Maximum ----- 3 Watts
 Plate load ----- 2000 Ohms

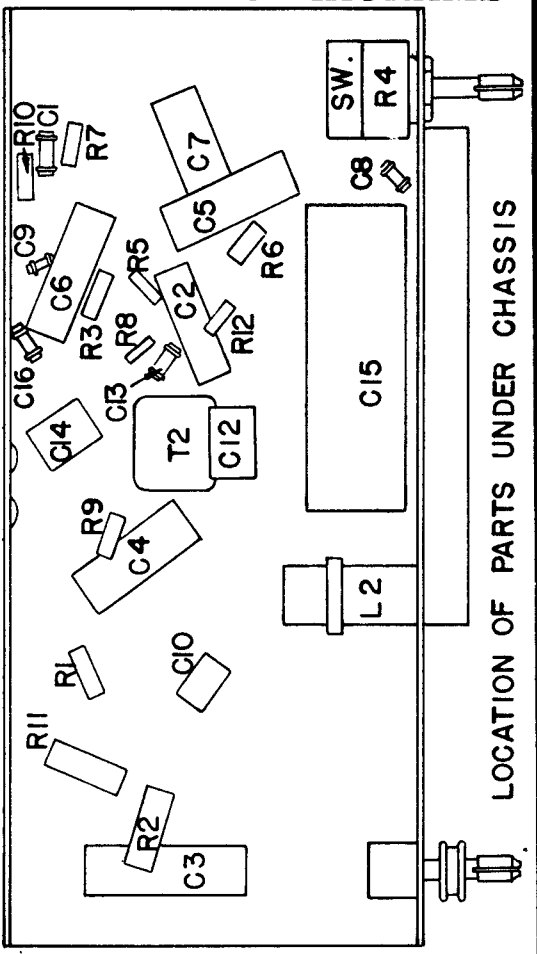

LOCATION OF PARTS UNDER CHASSIS

MANUAL OF 1950 MOST-OFTEN-NEEDED RADIO DIAGRAMS

ARVIN RADIO - MODELS 440T
 CHASSIS RE-278 - 4 TUBE AC - DC
 NOBLITT-SPARKS INDUSTRIES, Inc.

50L6GT/G

12SQ7GT/G

12SA7GT/G

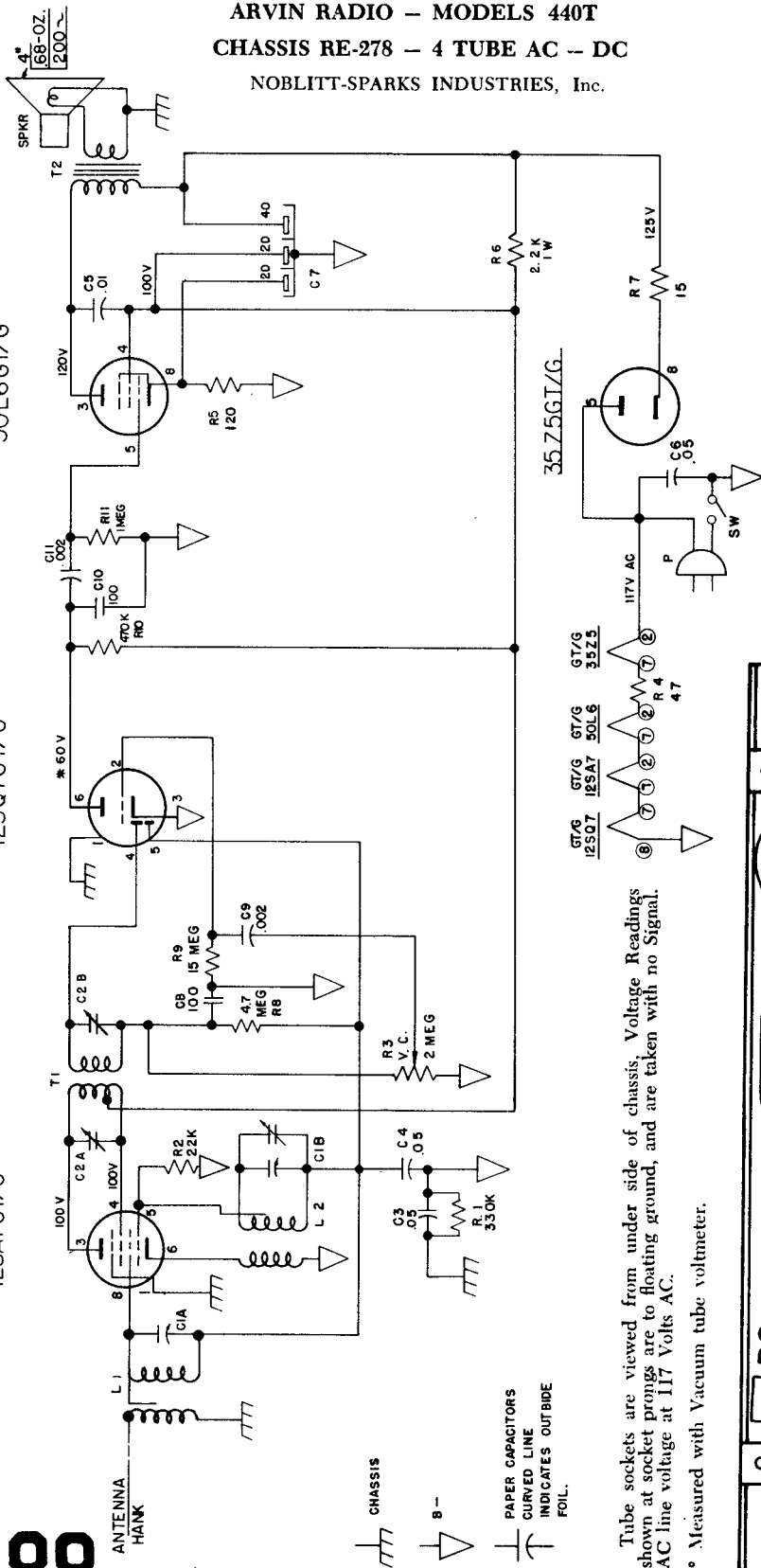

FREQUENCY RANGE
 Broadcast ----- 540-1600 kc
 IF ----- 455 kc

TUBES AND FUNCTIONS
 12SA7 ----- Mixer-oscillator
 12SQ7 ----- Detector - AVC-A.F.
 50L6GT ----- Output
 35Z5GT ----- Rectifier

POWER SUPPLY
 105-125 Volts, AC-DC, 30 Watts

POWER OUTPUT
 Type: Beam tube
 Undistorted ----- 1 Watt
 Maximum ----- 1.85 Watts
 Plate Load ----- 2000 Ohms

NOTE: Capacity Coupling is built in the antenna and oscillator coils. On some early Production sets, A 14 uuf. mica. Condenser will be used in place of the built in Capacity on the Antenna Coil.

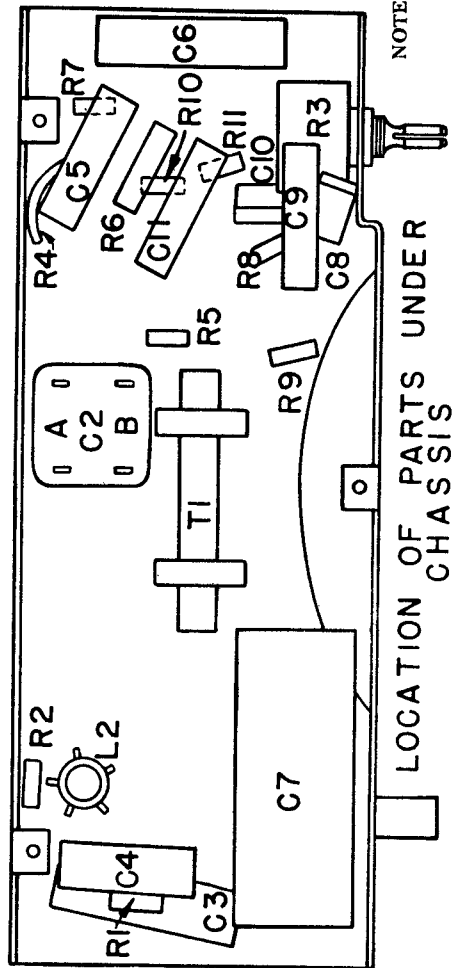

NOTE:

LOCATION OF PARTS UNDER CHASSIS

Tube sockets are viewed from under side of chassis, Voltage Readings shown at socket prongs are to floating ground, and are taken with no Signal. AC line voltage at 117 Volts AC.

• Measured with Vacuum tube voltmeter.

MANUAL OF 1950 MOST-OFTEN-NEEDED RADIO DIAGRAMS

PHILCO PORTABLE RADIO MODEL 50-621

The Philco material on this page and pages which follow has been supplied by the Philco Corporation through whose courtesy it is reproduced.

Philco Portable Radio Model 50-621, Complete Schematic Diagram

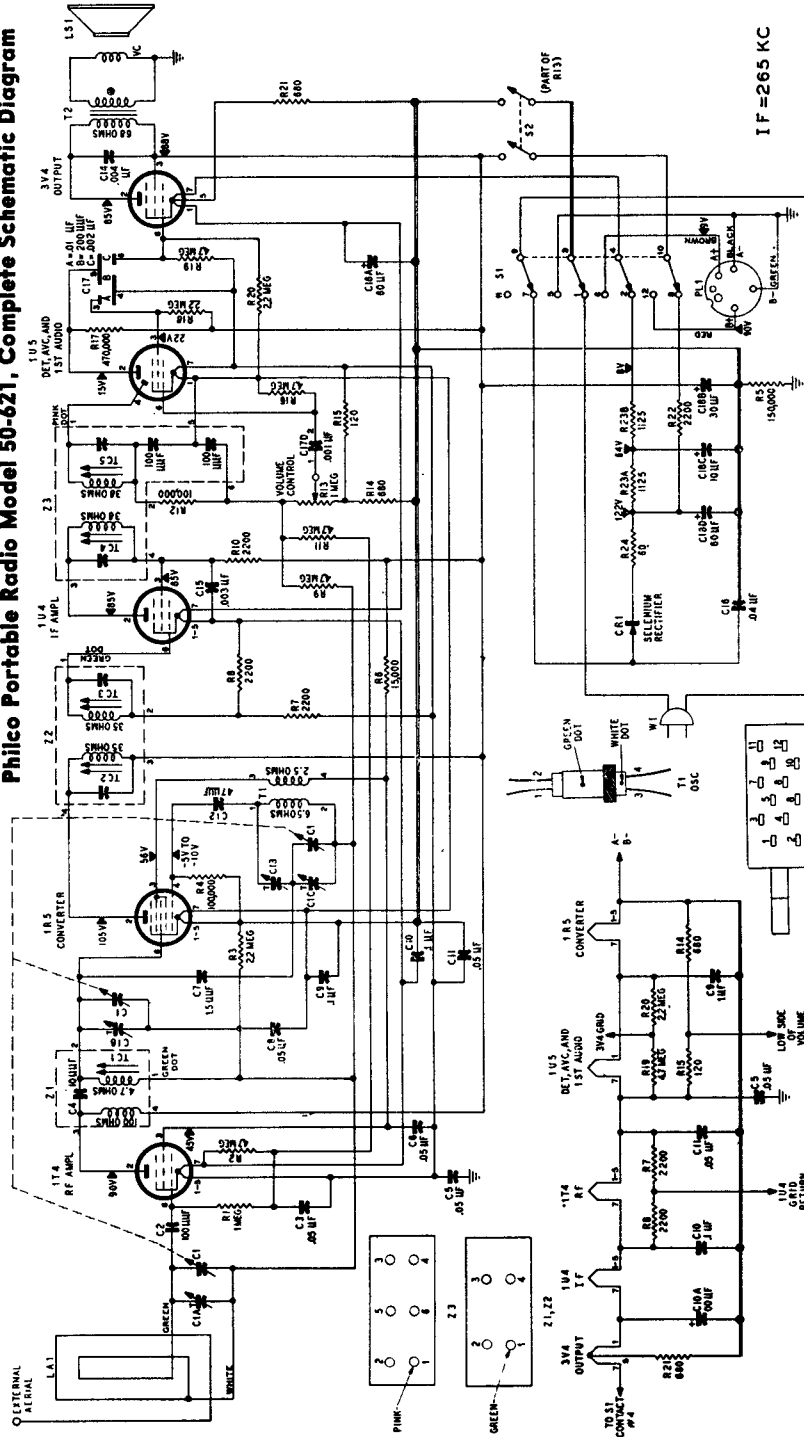

Bottom View, Showing Location of Parts

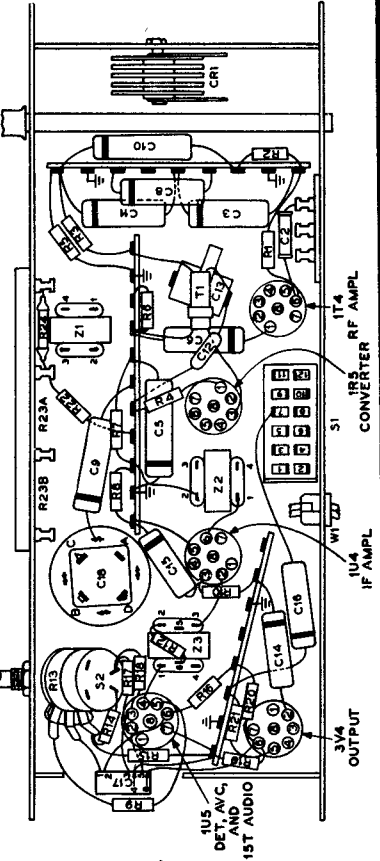

Top View, Showing Trimmer Locations

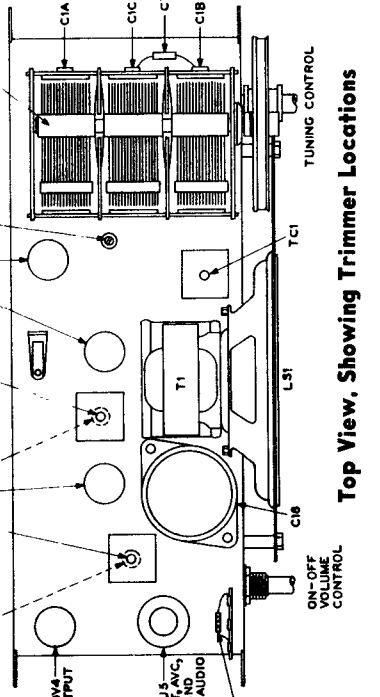

MANUAL OF 1950 MOST-OFTEN-NEEDED RADIO DIAGRAMS

PHILCO RADIO MODELS 50-522, 50-522-1 and 50-524

Philco TROUBLE-SHOOTING Procedure

For rapid trouble shooting, the radio circuit is divided into four sections, with test points specified for each section. These sections and test points are indicated in the schematic diagram. The trouble-shooting procedure given for each section includes a simplified test chart and a bottom view of the chassis showing the locations of the test points and the components of that section.

Section 1—Power Supply

For the tests in this section, use a d-c voltmeter. Connect the negative lead to B—, test point B; connect the positive lead to the test points indicated in the chart. The voltage readings given were taken with a 20,000-ohms-per-volt meter at a line voltage of 117 volts, a.c.
Turn on the power, and set the volume control to minimum.

If the "NORMAL INDICATION" is obtained in step 1, proceed with the tests for Section 2 (audio circuits); if not, isolate and correct the trouble in this section.

STEP	TEST POINT	NORMAL INDICATION	ABNORMAL INDICATION	POSSIBLE CAUSE OF ABNORMAL INDICATION
1	A	105 volts	No voltage	Trouble in this section. Isolate by the following tests. Defective: 35Z5GT. Open: W100, S100. Shorted: C100, C101A.
2	C	130 volts	Low voltage	Defective: 35Z5GT. Open: C101A. Leaky: C101A.
3	D	118 volts	High voltage No voltage	Open: R101. Shorted: C101B. Open: C101B. Shorted: C203. Leaky: C101B.
4	A	105 volts	High voltage No voltage Low voltage	Open: R102, T200*, R204*. Shorted: C101C. Leaky: C101C. Open: R204*. Open: R204*.

* This part, located in another section, may cause abnormal indication in this section.

Section 2—Audio Circuits

For the tests in this section, use an audio-frequency signal generator. Connect the generator ground lead to B—, test point B; connect the output lead through a .1- μ f. condenser to the test points indicated in the chart.

Set the volume control to maximum. If the "NORMAL INDICATION" is obtained in step 1, proceed with the tests for Sections 3 (i-f, detector, and a-v-c circuits); if not, isolate and correct the trouble in this section.

STEP	TEST POINT	NORMAL INDICATION	POSSIBLE CAUSE OF ABNORMAL INDICATION
1	A	Low, clear speaker output with weak signal input.	Trouble in this section. Isolate by the following tests.
2	C	Clear output with moderate signal input.	Defective: 50L6GT, L5200. Open: R204, T200. Shorted: C202, C203.
3	D	Same as step 1.	Defective: 148B (triode section). Open: C201, R202, R203. Shorted: C201.
4	A	Same as step 1.	Open: R200 (rotate through range), C200, R201. Shorted: C301D*.

* This part, located in another section, may cause abnormal indication in this section.

In each chart, the first step is a master check for determining whether trouble exists in that section without going through the entire test procedure.

Failure to obtain the "NORMAL INDICATION" in any given step indicates trouble within the circuit under test.

TROUBLE SHOOTING

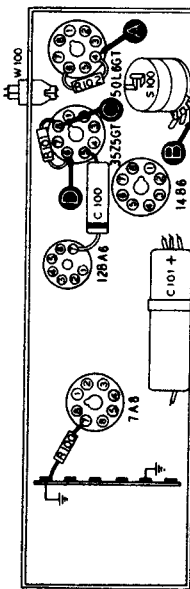

Figure 1. Bottom View, Showing Section 1 Test Points

Preliminary Checks

To avoid possible damage to the radio, the following preliminary checks should be made before it is turned on:

1. Inspect both the top and bottom of the chassis. Make sure that all tubes are secure in the proper sockets, and look for any broken or shorted connections, burned resistors, or other obvious indications of trouble.

Section 3—i-f, Detector, and A-V-C Circuits

For the tests in this section, use an r-f signal generator, with modulated output, set at 455 kc. Connect the generator ground lead to B—, test point B; connect the output lead through a .1- μ f. condenser to the test points indicated in the chart.

Set the volume control to maximum, and turn the tuning control until the tuning condenser is fully meshed.

If the "NORMAL INDICATION" is obtained in step 1, proceed with the tests for Section 4 (r-f and converter circuits); if not, isolate and correct the trouble in this section.

To provide a complete i-f amplifier check, test point A for this section is placed at the grid of the mixer in Section 4; therefore, the effectiveness of step 1 as a master check is dependent upon the condition of certain parts in the mixer circuit. These parts are listed below under "POSSIBLE CAUSE OF ABNORMAL INDICATION."

STEP	TEST POINT	NORMAL INDICATION	POSSIBLE CAUSE OF ABNORMAL INDICATION
1	A	Low, clear speaker output with weak signal input.	Trouble in this section. Isolate by the following tests.
2	C	Low, clear output with moderate input.	Defective: 12BA6, 148B, (diode section). Mismatch: Z301. Open: R300, C301A, C301B, L301A, L301B, R302, R303. Shorted: C302, C300B, C301A, C301B, C301C.
3	A	Same as step 1.	Defective: 7AB*. Mismatch: Z300. Open: L300A, L300B, R301, C300A, C300B. Shorted: C300A, C300, C400A.

* This part, located in another section, may cause abnormal indication in this section.

Section 4—R-F and Converter Circuits

For the tests in this section, with the exception of the oscillator test, use an r-f signal generator with modulated output. Connect the generator ground lead to B—, test point B; connect the output lead through a .1- μ f. condenser to the test points indicated in the chart.

Set the volume control to maximum. Set the tuning control and the signal-generator frequency as indicated in the chart.

If the "NORMAL INDICATION" is not obtained in step 1, isolate and correct the trouble in this section. If the trouble is not revealed by the tests for this section, check the alignment.

OSCILLATOR TEST: Connect the positive lead of a high-resistance voltmeter to B—, test point B; connect the proof end of the negative lead through a 100,000-ohm isolating resistor to the 7AB oscillator grid (pin 4), test point D. Use a suitable meter range, such as 0-10 volts. Proper operation of the oscillator is indicated by negative voltage of approximately the value given in the chart (measured with 20,000-ohms-per-volt meter), throughout the tuning range.

STEP	TEST POINT	NORMAL INDICATION	POSSIBLE CAUSE OF ABNORMAL INDICATION
1	A	Low, clear speaker output with weak signal input.	Trouble in this section. Isolate by the following tests.
2	C	Clear output with moderate signal input.	Defective: 7AB. Open: C401, T400, R400. Shorted: T400, C401, C400, C400B, C402.
3	D	Same as step 1.	Defective: 7AB. Open: L4400. Shorted: C400, C400A, L4400.
4	A	Same as step 1.	Open: L4400.

* This part, located in another section, may cause abnormal indication in this section.

2. Measure the resistance between B+ (test point C) and B— (test point B). See figure 1. When the ohmmeter test leads are connected in the proper polarity, the highest resistance reading will be obtained. If the reading is lower than 1500 ohms, check condensers C101A, C101B, C101C, and C203 for leakage or shorts. The resistance value given is much lower than normal, and is not intended as a quality check of these condensers; the value given is the lowest at which the rectifier will operate safely while the voltage checks of Section 1 (power supply) are performed.

TROUBLE SHOOTING

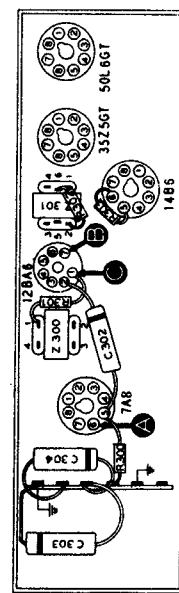

Figure 2. Bottom View, Showing Section 3 Test Points

TROUBLE SHOOTING

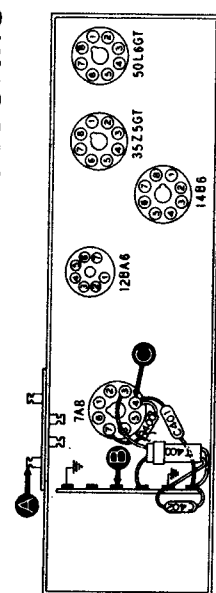
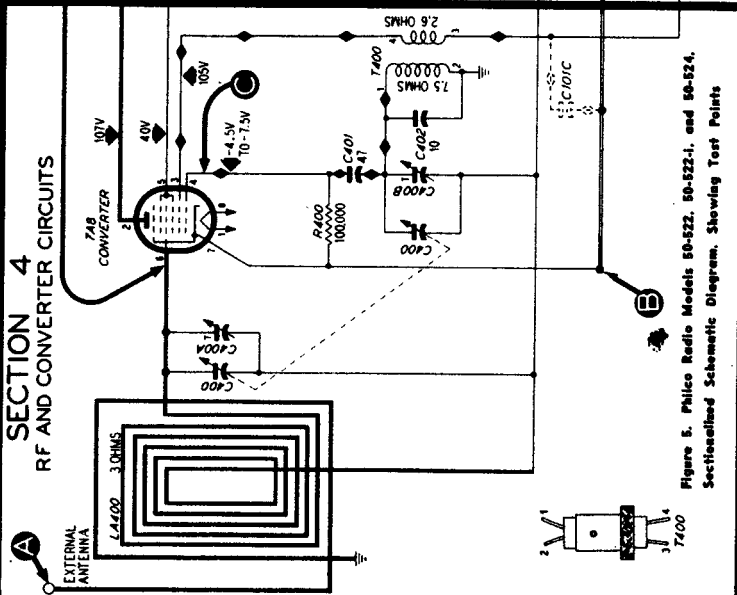
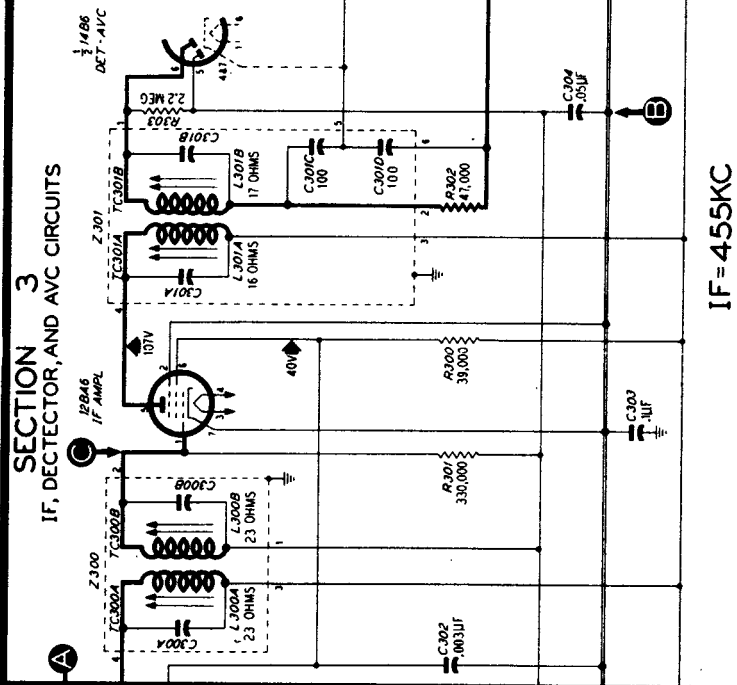

Figure 4. Bottom View, Showing Section 4 Test Points

SECTION 4 RF AND CONVERTER CIRCUITS



SECTION 3 IF, DETECTOR, AND AVC CIRCUITS



SECTION 2 AUDIO CIRCUITS

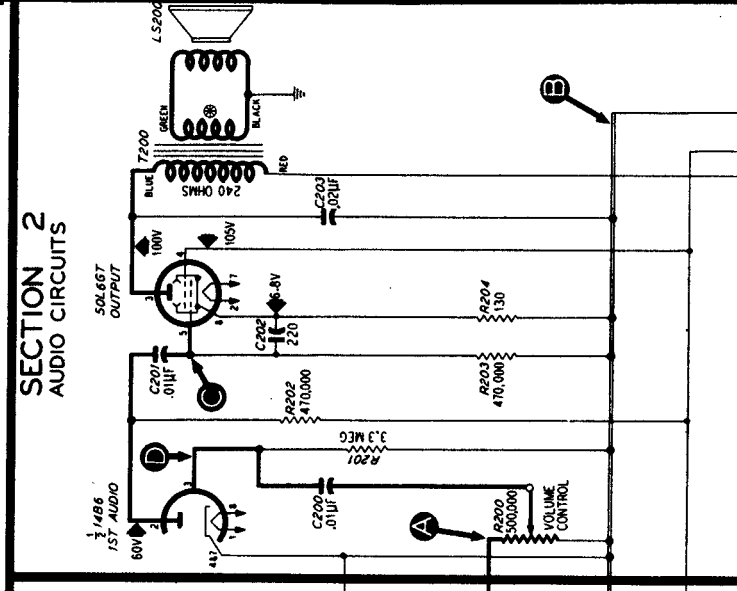

ALL VOLTAGES MEASURED WITH 20,000 OHMS-PER-VOLT METER BETWEEN POINTS AND 8 MINUS AT ALINE VOLTAGE OF 117V AC.

- CONDENSER SYMBOLS
- FIXED
 - VARIABLE
 - TRIMMER
 - COIL WITH TUNING CORE
- ALL RESISTOR VALUES IN OHMS UNLESS MARKED OTHERWISE.
ALL CONDENSER VALUES IN μF UNLESS MARKED OTHERWISE
- RF, IF, AND AUDIO SIGNAL PATH
OSCILLATOR SIGNAL PATH
● INDICATES LESS THAN 1 OHM

Figure 5. Philco Radio Models 50-522, 50-522-1, and 50-524. Sectionalized Schematic Diagram. Showing Test Points

IF = 455KC

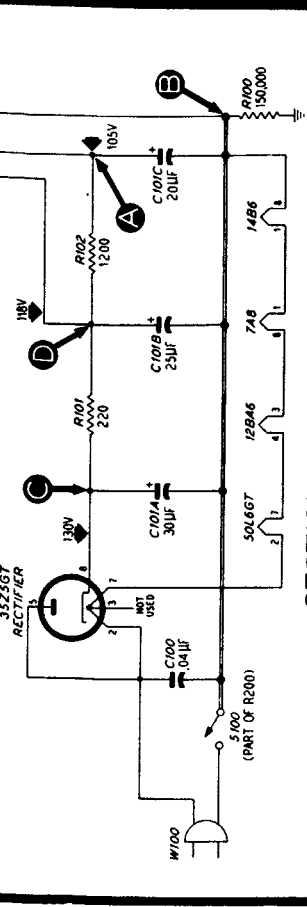

SECTION 1 POWER SUPPLY

MANUAL OF 1950 MOST-OFTEN-NEEDED RADIO DIAGRAMS

PHILCO RADIO MODEL 50-620

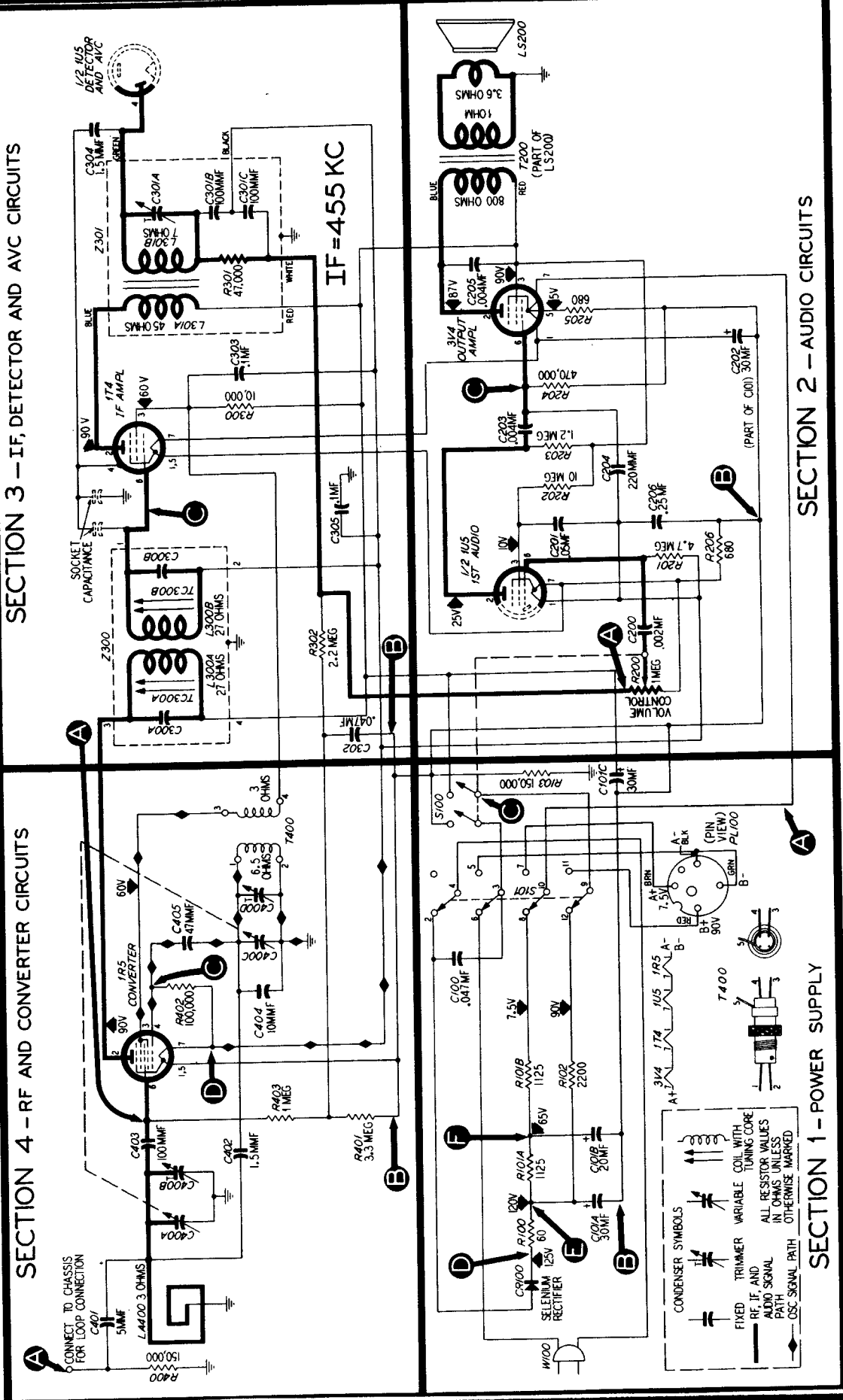

OSCILLATOR TEST. Connect the positive lead of a high-resistance voltmeter to test point D, connect the prod end of the negative lead through a 20,000-ohms-per-volt meter to the oscillator grid (pin 1 of the 1R5), test point C. Use a suitable meter range, such as 0—10 volts. Proper operation of the oscillator is indicated by negative voltage within the range given in the chart (measured with a 20,000-ohms-per-volt meter) throughout the tuning range.

TROUBLE SHOOTING

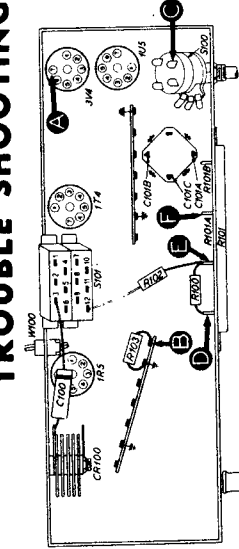

Figure 1. Bottom View, Showing Section 1 Test Points

If the "NORMAL INDICATION" is obtained in step 1, proceed with the tests for Section 2 (audio circuits); if not, isolate and correct the trouble in this section.

STEP	TEST POINT	NORMAL INDICATION	ABNORMAL INDICATION	POSSIBLE CAUSE OF ABNORMAL INDICATION
1	(a)	7.5v	Low voltage	Defective: CR100. Open: C101A.
1	(b)	80v	No voltage	Defective: R100. Open: S101. S101.
2	D	125v	Low voltage	Changed resistance: R100. Leaky: C101A.
3	E	120v	No voltage	Open: R100. Shorted: C101A.
4	F	65v	Low voltage	Changed resistance: R101A. Leaky: C101B.
5	A	7.5v	Low voltage	Open: R101A. Shorted: C101B.
5	A	7.5v	High voltage	Open: One or more filaments, R208.
6	C	00v	No voltage	Changed resistance: R102. Leaky: C101C.
6	C	00v	High voltage	Open: R208, T200, S100.
6	C	00v	No voltage	Open: R102, S101. Shorted: C101C.

*This part, located in another section, may cause abnormal indication in this section.

TROUBLE SHOOTING

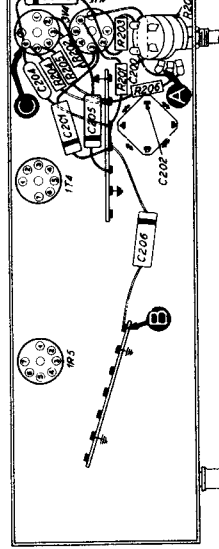

Figure 2. Bottom View, Showing Section 2 Test Points

If the "NORMAL INDICATION" is obtained in step 1, proceed with the tests for Section 3 (i-f, detector, and a-v-c circuits); if not, isolate and correct the trouble in this section.

STEP	TEST POINT	NORMAL INDICATION	ABNORMAL INDICATION	POSSIBLE CAUSE OF ABNORMAL INDICATION
1	A	Loud, clear speaker output with moderate generator input.	Loud, clear speaker output with strong generator input.	Trouble in this section. Isolate by the following tests.
2	C	Clear speaker output with strong generator input.	Distortion may be caused by leaky or shorted C203, or by changed resistance of R202. Distortion or strong signal may be caused by leaky or shorted C200.	Defective: 3V4, L2500. Open: R204, T200. Shorted: C203, C204, C205, T200.
3	A	Same as step 1.	Distortion may be caused by leaky or shorted C203, or by changed resistance of R202. Distortion or strong signal may be caused by leaky or shorted C200.	Defective: 1U5, R200 (noise). Open: C206, R201, R202, R203, C203. Shorted: C301C.

*This part, located in another section, may cause abnormal indication in this section.

Philco Model 50-620 is a portable four-tube super-heterodyne providing reception on the standard broadcast band. A high-impedance loop within the cabinet normally provides adequate signal pickup.

Battery: "B", 90 volts, "A", 7.5 volts, A.C./D.C., 105—120 volts.
 Battery: "B", 15 ma. at 90 volts; 25 watts high-impedance loop; see Built-in high-impedance loop; see Philco Model 50-620 for external aerial.

Section 3—I-F, Detector, And A-V-C Circuits

For the tests in this section, use an i-f signal generator, with modulated output, set at 455 kc. Connect the generator ground lead to B—, test point B; connect the output lead through a .1-mf. condenser to the test points indicated in the chart.

Set the radio volume control to maximum.

If the "NORMAL INDICATION" is obtained in step 1, proceed with the tests for Section 4 (r-f and converter circuits); if not, isolate and correct the trouble in this section.

To provide a complete i-f amplifier check, test point A for this section is placed at the grid of the mixer in Section 4; therefore, the effectiveness of step 1 as a master check is dependent upon the condition of certain parts in the mixer circuit. These parts are listed below under "POSSIBLE CAUSE OF ABNORMAL INDICATION."

STEP	TEST POINT	NORMAL INDICATION	ABNORMAL INDICATION	POSSIBLE CAUSE OF ABNORMAL INDICATION
1	A	Loud, clear speaker output with weak generator input.	Loud, clear speaker output with moderate generator input.	Trouble in this section. Isolate by the following tests.
2	C	Loud, clear output with moderate input.	Same as step 1.	Defective: 17A, 1U5 (diode section). Misaligned: Z301. Open: R300, C303, L301A, R301, L301B, C301A. Shorted: C300B, C300, L301A, L301B, C301A, C301B.
3	A	Same as step 1.	Same as step 1.	Defective: 1R5, Misaligned: Z300. Open: C400A, L300A, L300B, C300B, T400. Shorted: C400A, C400B, C300A, L300A, L300B, C300B.

*This part, located in another section, may cause abnormal indication in this section.

Section 4—R-F And Converter Circuits

For the tests in this section, with the exception of the oscillator test, use an r-f signal generator with modulated output. Connect the generator ground lead to B—, test point B; connect the output lead through a .1-mf. condenser to the test points indicated in the chart.

Set the radio volume control to maximum. Set the tuning control and signal-generator frequency as indicated in the chart.

If the "NORMAL INDICATION" is obtained in step 1, further tests should be unnecessary; if not, isolate and correct the trouble in this section. If the trouble is not revealed by the tests for this section, check the alignment.

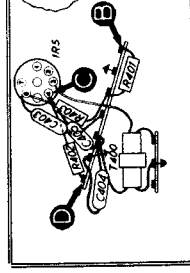

Figure 3. Bottom View, Showing Section 3 Test Points

TROUBLE SHOOTING

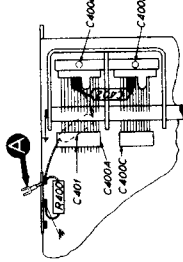

Figure 4. Bottom View, Showing Section 4 Test Points

STEP	TEST POINT	SIGNAL-FREQ FREQUENCY	RADIO TUNING	NORMAL INDICATION	POSSIBLE CAUSE OF ABNORMAL INDICATION
1	A	1000 kc.	Tune to signal.	Loud, clear speaker output with weak generator input.	Trouble in this section. Isolate by the following tests.
2	C to D (Use test; see note below.)	1000 kc.	Rotate through range.	Negative 5 to 10 volts.	Defective: 1R5. Open: R402, T400, C405. Shorted: C402, C403C, C400D.
3	A	1000 kc.	Tune to signal.	Same as step 1.	Open: C401, C403, R401, C403, L400A.



MODEL 50-620

MANUAL OF 1950 MOST-OFTEN-NEEDED RADIO DIAGRAMS

PHILCO RADIO MODELS 50-925, Code 123, and 50-926

AM ALIGNMENT PROCEDURE

Make alignment with loop aerial connected to radio. The AM alignment should be completed before the FM alignment is made.

DIAL POINTER — With tuning-condenser plates fully meshed, adjust pointer to coincide with index mark at low-frequency end of scale.

RADIO CONTROLS — Set volume control to maximum, set band switch for broadcast reception, and set tuning control as indicated in chart.

OUTPUT METER — Connect across voice-coil terminals.

SIGNAL GENERATOR — Use AM r-f signal generator, with modulated output. Connect generator and set frequency as indicated in chart.

OUTPUT LEVEL — During alignment, signal-generator output must be attenuated to hold output-meter reading below 1.25 volts.

FM ALIGNMENT PROCEDURE

Make AM alignment first.

RADIO CONTROLS — Set volume control to maximum, set band switch for FM reception, and set tuning control as indicated in chart.

OUTPUT METER — Connect across voice-coil terminals. (This meter is used only for step 3.)

D-C VOLTMETER — Connect negative lead of d-c voltmeter (resistance of at least 20,000 ohms per volt) to pin 2 of 9X8 tube, and positive lead to chassis. Use 0-10-volt range.

SIGNAL GENERATOR — Use AM r-f signal generator, with modulated output. Connect ground lead to chassis. Connect output lead and set frequency as indicated in chart. Generator must have sufficient output to give reading of approximately 8.5 volts on d-c voltmeter; during alignment, generator output must be attenuated to hold meter reading at this value.

NOTE: Before starting FM alignment, allow radio and signal generator to warm up for 15 minutes.

AM ALIGNMENT CHART

STEP	SIGNAL GENERATOR CONNECTION TO RADIO		DIAL SETTING	RADIO		ADJUST
	CONNECTION TO RADIO	DIAL SETTING		SPECIAL INSTRUCTIONS		
1	Ground lead to chassis. Connect lead through a .1- μ f. condenser to antenna grid (pin 7) of 12A7.	435 kc.	540 kc. (ground fully meshed)	Adjust for maximum output.		TC10—2nd AM I-f sec. TC9—2nd AM I-f prl. TC8—1st AM I-f sec. TC8—1st AM I-f prl.
2	2nd-order loop. (See note below.)	1800 kc.	1800 kc.	Adjust for maximum output.	C1C—osc. trimmer	
3	Same as step 2.	1800 kc.	1800 kc.	Adjust for maximum output.	C1B—modulated trimmer	

BLENDING LOOP. Make up a six-to-eight-inch, 4-inch-diameter loop from barebacked wire; connect to generator terminals, and place right outside loop control. Leads loop control must be connected.

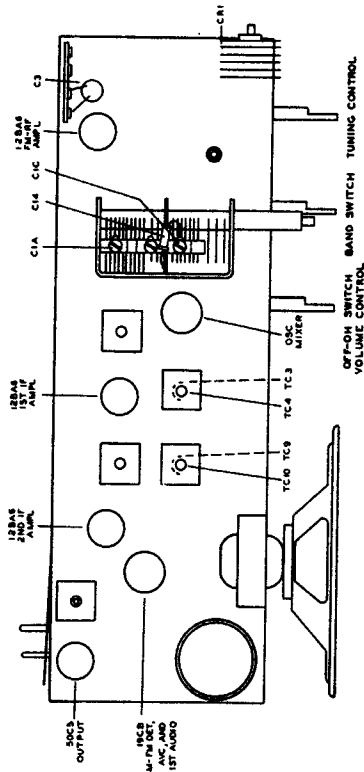

Top View, Showing AM Trimmer Locations

FM ALIGNMENT CHART

STEP	SIGNAL GENERATOR CONNECTION TO RADIO		DIAL SETTING	SPECIAL INSTRUCTIONS	ADJUST
	CONNECTION TO RADIO	DIAL SETTING			
1	Through a .1- μ f. condenser to antenna grid (pin 1) of 12BA8 1st I-f amp.	8.1 mc.	88 mc.	Adjust tuning cores for maximum reading on d-c voltmeter. Attenuate signal generator to condition of reading of approximately 8.5 volts. Repeat adjustment until no further improvement is noted. After this step, do not disturb these tuning cores except as directed in step 2.	TC8—discriminator sec. TC7—discriminator prl. TC8—FM 2nd I-f sec. TC8—FM 2nd I-f prl.
2	Through a .1- μ f. condenser to antenna grid (pin 7) of 12A7.	8.1 mc.	90 mc.	Adjust tuning cores for maximum reading on d-c voltmeter. Repeat adjustment until no further improvement is noted. Do not disturb these tuning cores after this step.	TC2—FM 1st I-f sec. TC1—FM 1st I-f prl.
3	Same as step 1.	8.1 mc.	90 mc.	Adjust tuning cores for maximum reading on d-c voltmeter. This adjustment is critically repeat to make certain it is correct.	TC3—discriminator sec.
4	To terminal 1 of J1.	105 mc.	105 mc.	Adjust trimmer for maximum reading on d-c voltmeter.	C12—FM osc.
5	Same as step 4.	105 mc.	105 mc.	Same as step 4.	
6	Same as step 4.	83 mc.	83 mc.	Adjust coil for maximum reading on d-c voltmeter.	C1B—FM r-f
7	Same as step 4.	00 mc.	00 mc.	Same as step 6.	L4—osc. (broadband)
8	Same as step 4.	105 mc.	105 mc.	Same as step 4.	L3—FM r-f (broadband)
9	Repeat steps 4 through 8 until no further improvement is noted.				C11—FM osc.

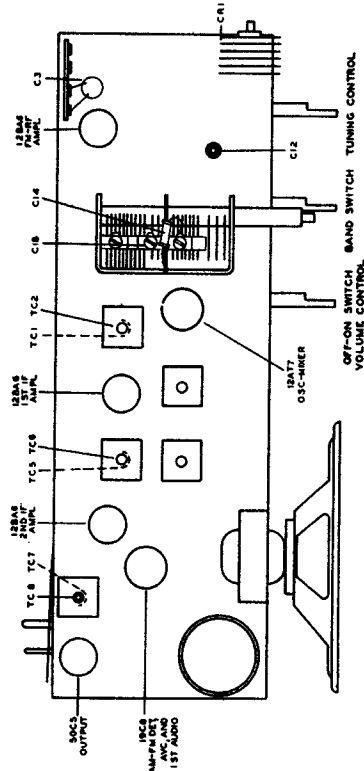

Top View, Showing FM Trimmer Locations

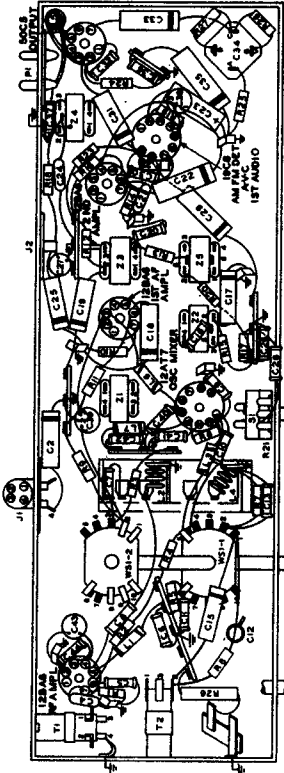

Symbolized Chassis, Showing Parts Placement

OFF-ON SWITCH
VOLUME CONTROL
TUNING CONTROL
BAND SWITCH

CENTRAL LEAD WIRE WILL REMAIN UNLESS PLUG REGULATOR WILL REMAIN UNLESS UNIT IS REMOVED FROM CHASSIS. THE RED LEAD BETWEEN PIN 8 OF THE LAST TUBE AND PIN 4 OF Z1 IS DESIRED, AND PARTS 25 AND HORIZONTAL TO THE CHASSIS (NOT DRESSED DOWN TO THE CHASSIS)

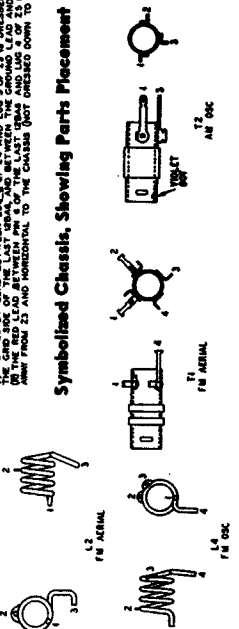

CONDENSER SYMBOLS

FIXED VARIABLE TRIMMER ELECTRETIC CONDENSER

ALL VARIATION VALUES IN TUBES AND ALL CONDENSER VALUES IN FRONT PANELS INDICATED BY THIS METER WITH A LINE THROUGH IT. METERS WITH A LINE THROUGH IT INDICATE VALUES LESS THAN 1 OHM

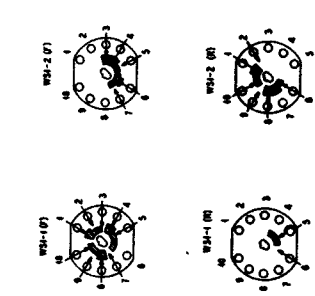

REL POSITION WAXER SWITCH SHOWN IN REAR POSITION

W1-1 (A) INDICATES FRONT CONTACTS LOOKING FROM FRONT THROUGH AIR

W1-2 (B) INDICATES REAR CONTACTS LOOKING THROUGH FRONT THROUGH AIR

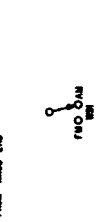

Dial-Card Installation Details

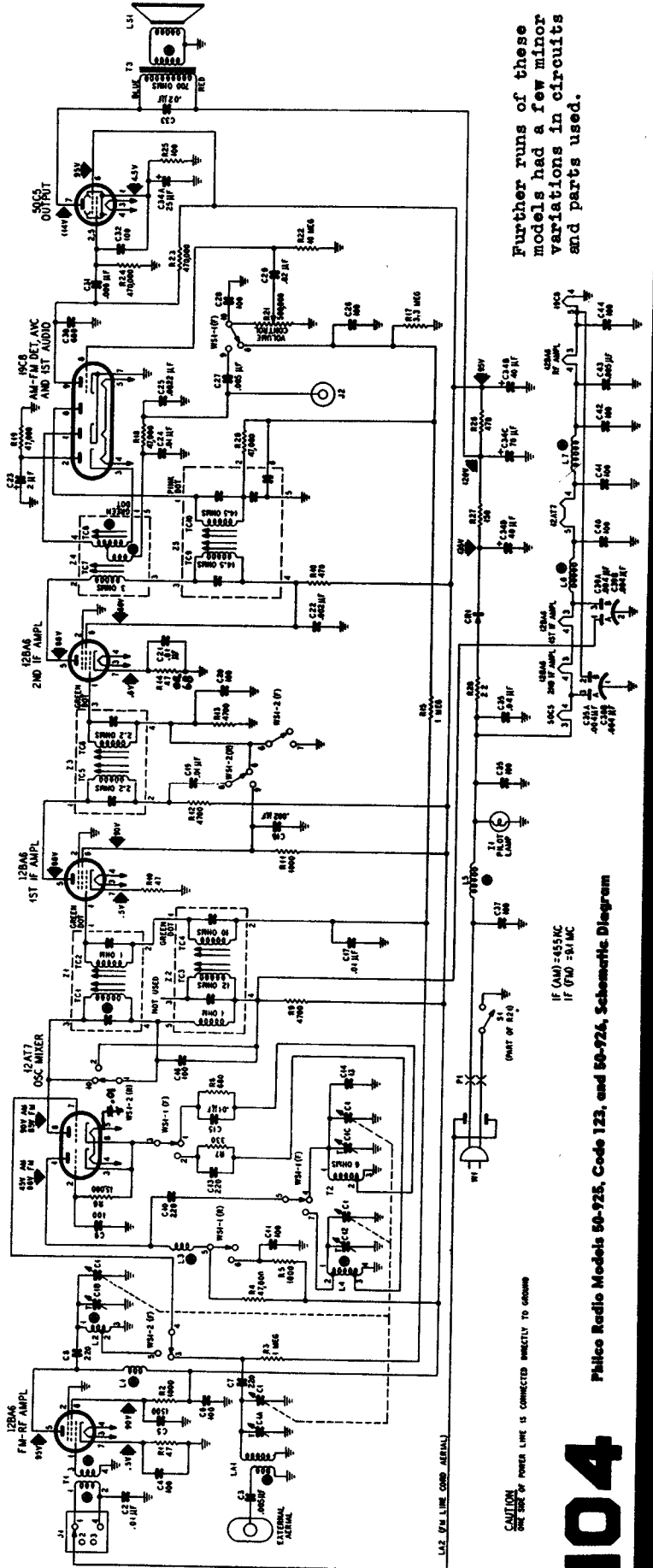
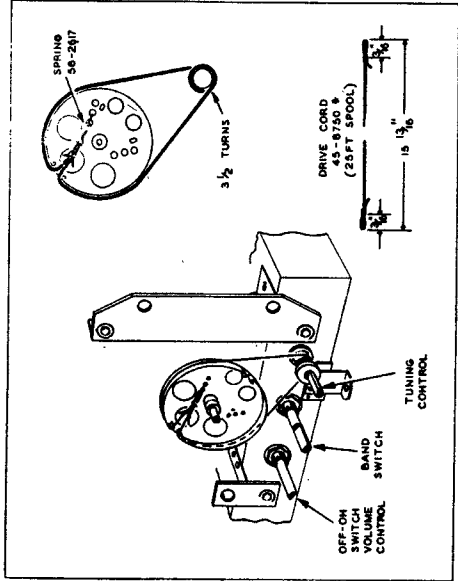

CAUTION
THE BOND OF POWER LINE IS CONNECTED DIRECTLY TO GROUND

IF (AM) = 655 KC
IF (FM) = 541 MC

Further runs of these models had a few minor variations in circuits and parts used.

Philco Radio Models 50-925, Code 123, and 50-924, Schematic Diagram

MANUAL OF 1950 MOST-OFTEN-NEEDED RADIO DIAGRAMS

PHILCO RADIO MODELS 50-920, 50-921 AND 50-922

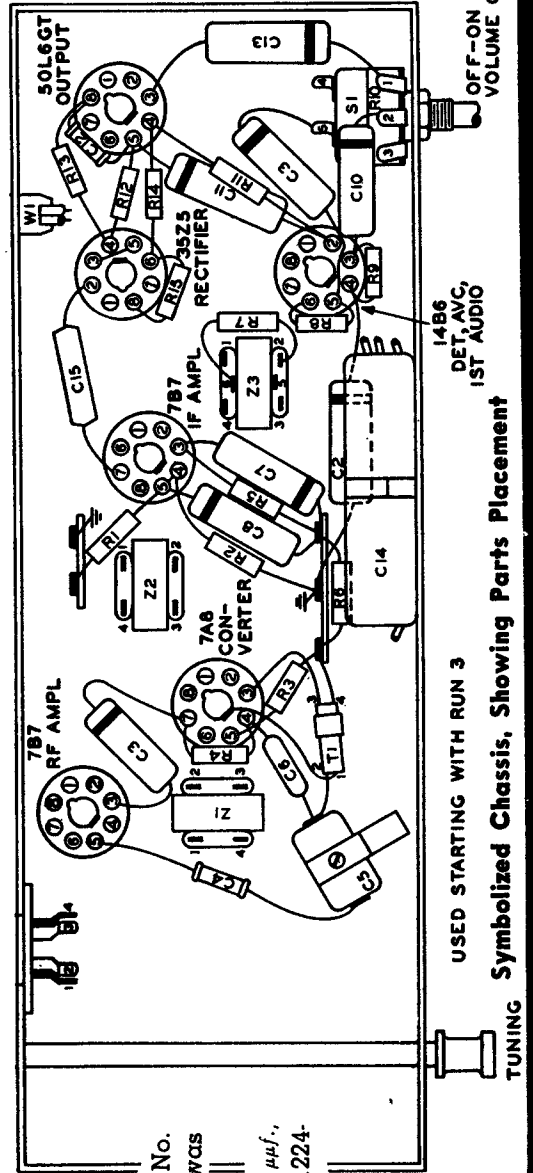
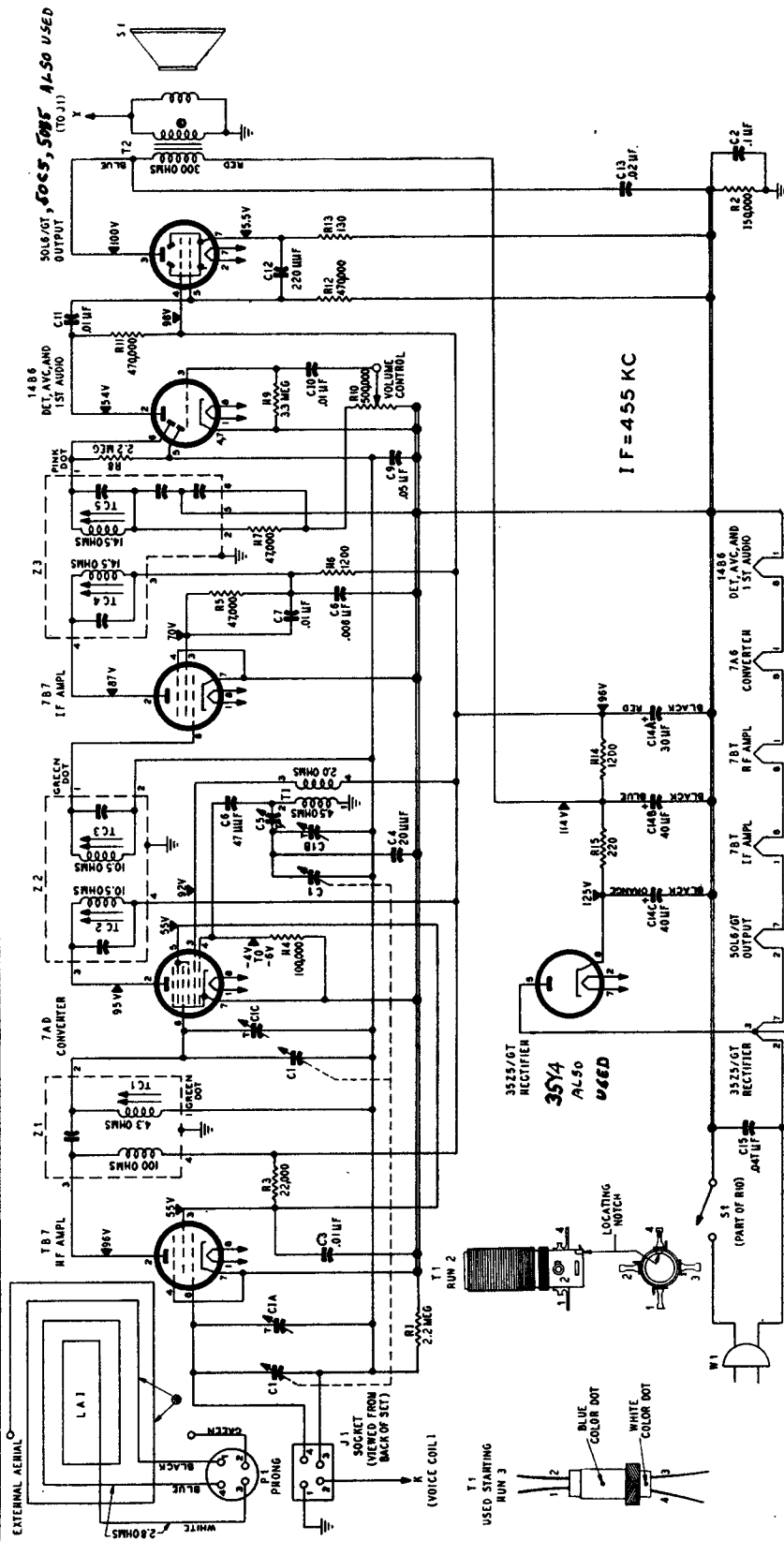

PRODUCTION CHANGES

Run 2: I.F. changed from 265 kc. to 455 kc.

Run 3: Oscillator coil, T1, changed from Part No. 32-4190-6 to Part No. 32-4263-3. This change was to save space only.

Run 4: Condenser C4 changed in value from $20 \mu\text{f.}$, Part No. 30-1224-56, to $13 \mu\text{f.}$, Part No. 30-1224-68, to insure proper padding at 1620 kc.

OSCILLATOR VOLTAGE MEASURED ACROSS R4, POSITIVE LEAD TO B; NEGATIVE LEAD TO PIN #4 WITH A 10000 OHM RESISTOR IN SERIES. 2000V/10M/VOLTS, 10 VOLT RANGE. ALL OTHER VOLTAGES MEASURED WITH A 20000-OHMS-PER-VOLT VOLTMETER BETWEEN POINTS INDICATED BY AT A LINE VOLTAGE OF 117V AC.

MANUAL OF 1950 MOST-OFTEN-NEEDED RADIO DIAGRAMS

PHILCO RADIO-PHONOGRAPH MODEL 50-1420

PHILCO RADIO-PHONOGRAPH MODELS 50-1421 50-1422 AND 50-1423

These two models are similar to Model 50-1420.

Section 1—Power Supply

For the tests in this section, use a d-c voltmeter. Connect the negative lead to B—, test point B; connect the positive lead to the test points indicated in the chart. The voltage readings given were taken with a 20,000-ohms-per-volt meter at a line voltage of 117 volts, a.c.

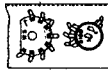

Figure 1. Bottom View, Showing Section 1 Test Points

STEP	TEST POINT	NORMAL INDICATION	ABNORMAL INDICATION	POSSIBLE CAUSE OF ABNORMAL INDICATION
1	A	120 volts	No voltage	Trouble in this section. Isolate by the following tests. Defective: 50V7GT, T100. Shorted: C106, C181, C102A.
2	C	213 volts	Low voltage	Leaky: R106, C181, C102A.
3	D	205 volts	High voltage	Open: R106.
			No voltage	Defective: 50V7GT. Shorted: C102B. Open: R106.
4	A	126 volts	Low voltage	Leaky: C102B.
			High voltage	Open: R101, R182, T200*.
			No voltage	Shorted: C102C.
			Low voltage	Open: R101 and R182 (in parallel). Leaky: C102C.

* This part, located in another section, may cause abnormal indication in this section.

Section 2—Audio Circuits

For the tests in this section, use an audio-frequency signal generator. Connect the generator ground lead to B—, test point B; connect the output lead through a .1-mf. condenser to the test points indicated in the chart. Set the radio volume control to maximum, and the radio

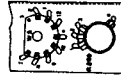

Figure 2. Bottom View, Showing Section 2 Test Points

STEP	TEST POINT	RADIO-PHONO SWITCH	NORMAL INDICATION	POSSIBLE CAUSE OF ABNORMAL INDICATION
1 (a)	A	Radio	Load, clear speaker output with moderate generator input.	Trouble in this section. Isolate by the following tests.
1 (b)	E	Phono	Clear output with strong input.	Defective: L2500, 35L6GT. Shorted: T200, C203, C281, C283. Open: C202.
2	C	Radio	Load, clear output with moderate input.	Defective: 6L06. Shorted: C204, C205. Open: C201, R202, R201, R206. Leaky: C201.
3	D	Radio	Load, clear output with moderate input.	Open: R200 (rotary), C200, W3. Shorted: W3.
4	A	Radio	Load, clear output with moderate input.	Open or shorted: W3.
5	E	Phono	Same as step 4.	Open or shorted: W3.

Listening Test: Distortion may be caused by leaky C201. Distortion on strong signals may be caused by shorted or leaky C200.

TROUBLE SHOOTING

Turn on the power, and set the volume control to minimum.

If the "NORMAL INDICATION" is obtained in step 1, proceed with the tests for Section 2 (audio circuits); if not, isolate and correct the trouble in this section.

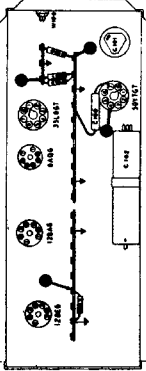

Figure 3. Bottom View, Showing Section 3 Test Points

STEP	TEST POINT	NORMAL INDICATION	POSSIBLE CAUSE OF ABNORMAL INDICATION
1	A	Load, clear speaker output with weak generator input.	Trouble in this section. Isolate by the following tests.
2	C	Load, clear output with strong input.	Defective: 12BA6, 6A06. Shorted: C300B, C301A, C301B, C301C, C301D, C301E, C301F, C300A, L301B, L301C. Open: C302, R303, L301A, L301B, L301C, R301, C301A, C301B. Leaky: C302, C301.
3	A	Load, clear output with weak input.	Defective: 12BE6*. Shorted: C400A*, C400B*, C300A, L300A, L300B, C302. Open: L300A, R300, C300A, C300B. Misaligned: Z300.

* This part, located in another section, may cause abnormal indication in this section.

TROUBLE SHOOTING

Turn on the power, and set the volume control to minimum. If the "NORMAL INDICATION" is obtained in step 1, proceed with the tests for Section 3 (i-f, detector, and a-v-c circuits); if not, isolate and correct the trouble in this section.

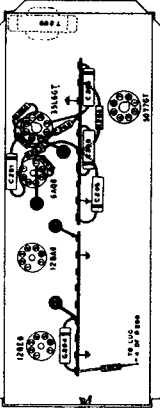

Figure 4. Bottom View, Showing Section 4 Test Points

STEP	TEST POINT	SIG. GEN. FREQ.	RADIO TUNING	NORMAL INDICATION	POSSIBLE CAUSE OF ABNORMAL INDICATION
1	A	1000 kc.	Tune to signal.	Load, clear speaker output with weak generator input.	Trouble in this section. Isolate by the following tests.
2	C—D	Occ. Test (see note below).	Rotate through range.	Negative 1.8 to 3.2 volts.	Defective: 12BE6. Shorted: C400, C400B, C402, C401, L400A, L400B. Open: C402, C400A, L400B, R401, R402. Shorted: LA400, C400A, C400A. Open: LA400, C404.
3	A	1000 kc.	Tune to signal.	Same as step 1.	

OSCILLATOR TEST: Connect the positive lead of a high-resistance voltmeter to the oscillator cathode (pin 2 of 12BE6) test point D; connect the other end of the negative lead through a 100,000-ohm isolating resistor to the oscillator grid (pin 1 of 12BE6) test point C. Use a suitable meter range, such as 0–10 volts. Proper operation of the oscillator is indicated by negative voltage within the range given in the chart (measured with a 20,000-ohms-per-volt meter) throughout the tuning range.

Section 3—i-f, Detector, and A-V-C Circuits

For the tests in this section, use an r-f signal generator, with modulated output, set at 455 kc. Connect the generator ground lead to B—, test point B; connect the output lead through a .1-mf. condenser to the test points indicated in the chart.

Set the radio volume control to maximum, and the radio-phono switch to the radio position. Rotate the tuning control until the tuning condenser is fully meshed.

If the "NORMAL INDICATION" is obtained in step 1, proceed with the tests for Section 4 (r-f and converter circuits); if not, isolate and correct the trouble in this section.

To provide a complete i-f amplifier check, test point A for this section is placed at the grid of the mixer in Section 4; therefore, the effectiveness of step 1 as a mixer check is dependent upon the condition of certain parts in the mixer circuit. These parts are listed below under "POSSIBLE CAUSE OF ABNORMAL INDICATION".

STEP	TEST POINT	NORMAL INDICATION	POSSIBLE CAUSE OF ABNORMAL INDICATION
1	A	Load, clear speaker output with weak generator input.	Trouble in this section. Isolate by the following tests.
2	C	Load, clear output with strong input.	Defective: 12BA6, 6A06. Shorted: C300B, C301A, C301B, C301C, C301D, C301E, C301F, C300A, L301B, L301C. Open: C302, R303, L301A, L301B, L301C, R301, C301A, C301B. Leaky: C302, C301.
3	A	Load, clear output with weak input.	Defective: 12BE6*. Shorted: C400A*, C400B*, C300A, L300A, L300B, C302. Open: L300A, R300, C300A, C300B. Misaligned: Z300.

* This part, located in another section, may cause abnormal indication in this section.

Section 4—R-F and Converter Circuits

For the tests in this section, with the exception of the oscillator test, use an r-f signal generator with modulated output. Connect the generator ground lead to B—, test point B; connect the output lead through a .1-mf. condenser to the test points indicated in the chart.

Set the radio volume control to maximum, and the radio-phono switch to the radio position. Set the tuning control and signal-generator frequency as indicated in the chart.

If the "NORMAL INDICATION" is obtained in step 1, further tests should be unnecessary; if not, isolate and correct the trouble in this section. If the trouble is not revealed by the tests for this section, check the alignment.

TROUBLE SHOOTING

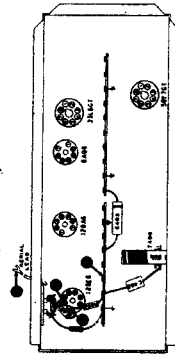

Figure 4. Bottom View, Showing Section 4 Test Points

SECTION 2
AUDIO CIRCUITS

SECTION 3
IF, DETECTOR, AND AVC CIRCUITS

SECTION 4
RF AND CONVERTER CIRCUITS

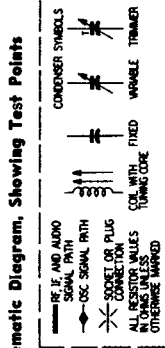
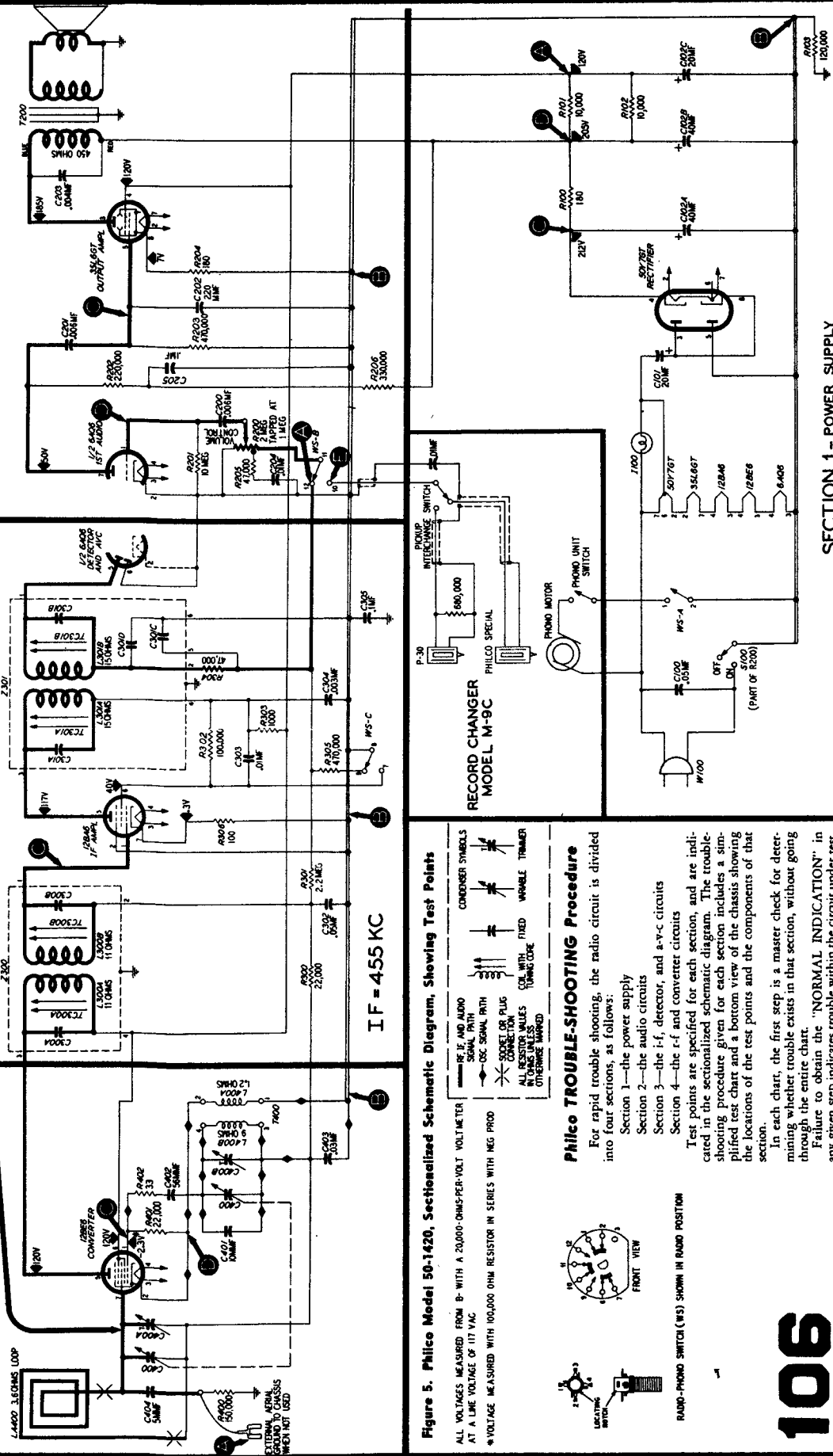

Figure 5. Philco Model 50-1420, Sectionalized Schematic Diagram, Showing Test Points

ALL VOLTAGES MEASURED FROM B- WITH A 20,000-OHM-PER-VOLT VOLTMETER AT A LINE VOLTAGE OF 117 VAC

* VOLTAGE MEASURED WITH 100,000 OHM RESISTOR IN SERIES WITH NEG GRID

Philco TROUBLE-SHOOTING Procedure

For rapid trouble shooting, the radio circuit is divided into four sections, as follows:

Section 1—the power supply

Section 2—the audio circuits

Section 3—the i-f, detector, and a-v-c circuits

Section 4—the r-f and converter circuits

Test points are specified for each section, and are indicated in the sectionalized schematic diagram. The troubleshooting procedure given for each section includes a simplified test chart and a bottom view of the chassis showing the locations of the test points and the components of that section.

In each chart, the first step is a master check for determining whether trouble exists in that section, without going through the entire chart.

Failure to obtain the "NORMAL INDICATION" in any given step indicates trouble within the circuit under test.

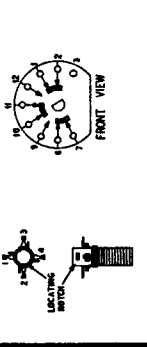

PHONO-PHONO SWITCH (WS) SHOWN IN NORMAL POSITION

MANUAL OF 1950 MOST-OFTEN-NEEDED RADIO DIAGRAMS

PHILCO MODEL 50-1424

ALL RESISTOR VALUES IN OHMS UNLESS OTHERWISE MARKED

VOLTAGES MEASURED WITH 20,000-OHMS-PER-VOLT VOLTMETER FROM POINTS INDICATED TO B MINUS AT A LINE VOLTAGE OF 117V AC

⊗ LESS THAN 1 OHM

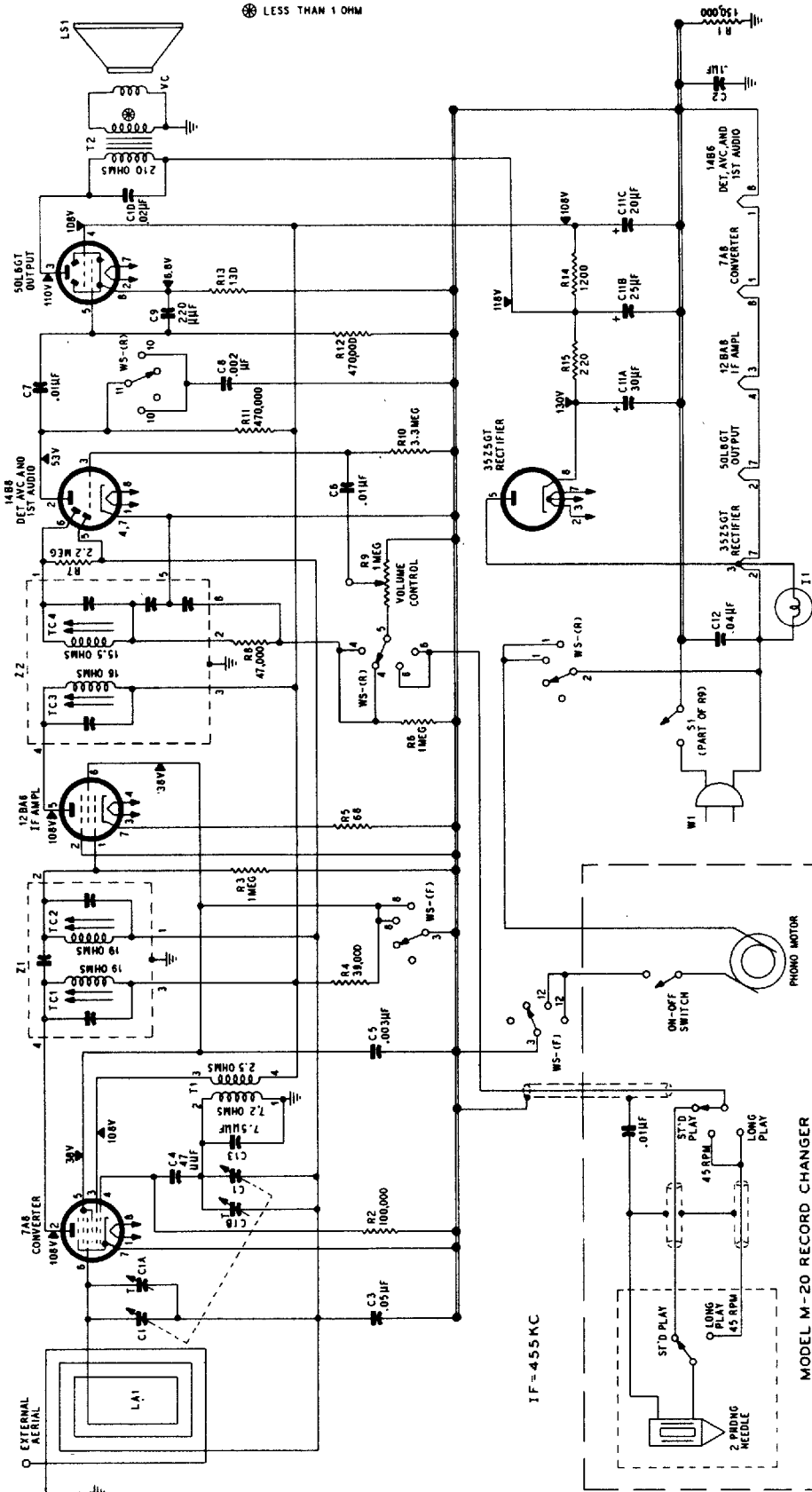

STEP	SIGNAL GENERATOR		RADIO		ADJUST
	CONNECTION TO RADIO	DIAL SETTING	DIAL SETTING	SPECIAL INSTRUCTIONS	
1	Ground lead to B; output lead through .1-µf. condenser to pin 6 of 7A8 tube.	455 kc.	540 kc. (gang fully meshed).	Adjust tuning cores, in order given, for maximum output.	TC4—2nd 1/4 sec. TC3—2nd 1/4 pri. TC2—1st 1/4 sec. TC1—1st 1/4 pri.
2	Radiating loop (see note below).	1600 kc.	1600 kc.	Adjust for maximum.	C1B—osc.
3	Same as step 2.	1500 kc.	1500 kc.	Adjust for maximum.	C1A—cerial

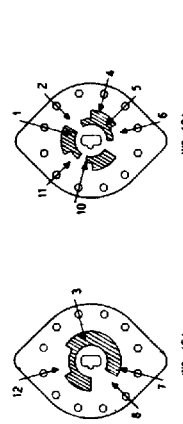

WAFER SWITCH SHOWN (IN RADIO POSITION) WITH CHASSIS INVERTED
 (F) INDICATES FRONT CONTACTS LOOKING FROM FRONT
 (R) INDICATES REAR CONTACTS LOOKING THROUGH FROM FRONT

MANUAL OF 1950 MOST-OFTEN-NEEDED RADIO DIAGRAMS

PHILCO RADIO-PHONOGRAPH MODEL 50-1718

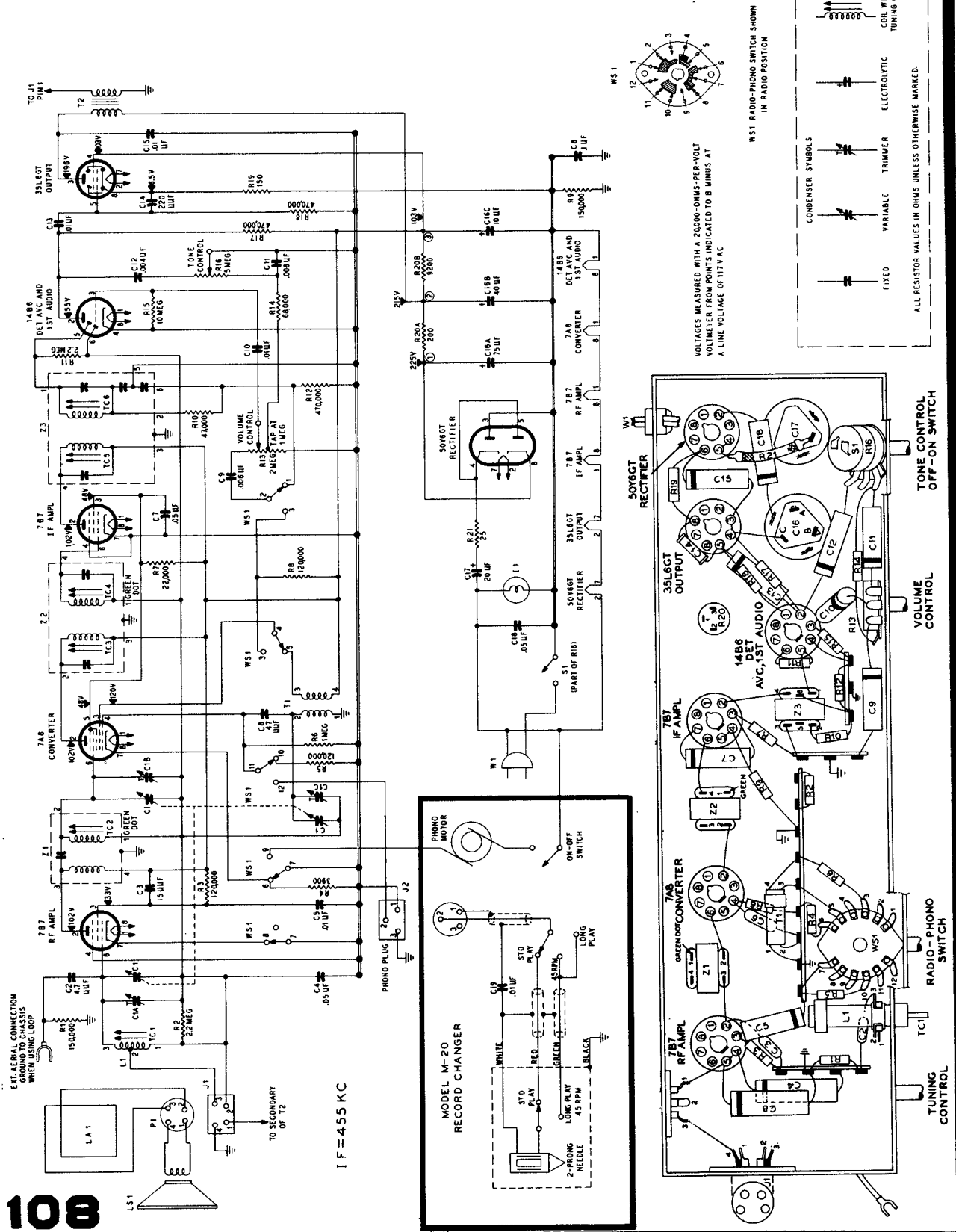

WS1 RADIO-PHONO SWITCH SHOWN IN RADIO POSITION
VOLTAGES MEASURED WITH A 20000-OHMS-PER-VOLT VOLTMETER FROM POINTS INDICATED TO B MINUS AT A LINE VOLTAGE OF 117 V AC

WS1 RADIO-PHONO SWITCH SHOWN IN RADIO POSITION

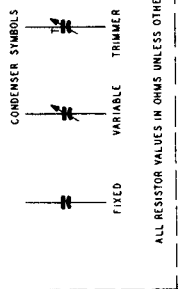

- CONDENSER SYMBOLS
 - FIXED
 - VARIABLE
 - TRIMMER
 - ELECTROLYTIC
 - COIL WITH TUNING CORE
- ALL RESISTOR VALUES IN OHMS UNLESS OTHERWISE MARKED.

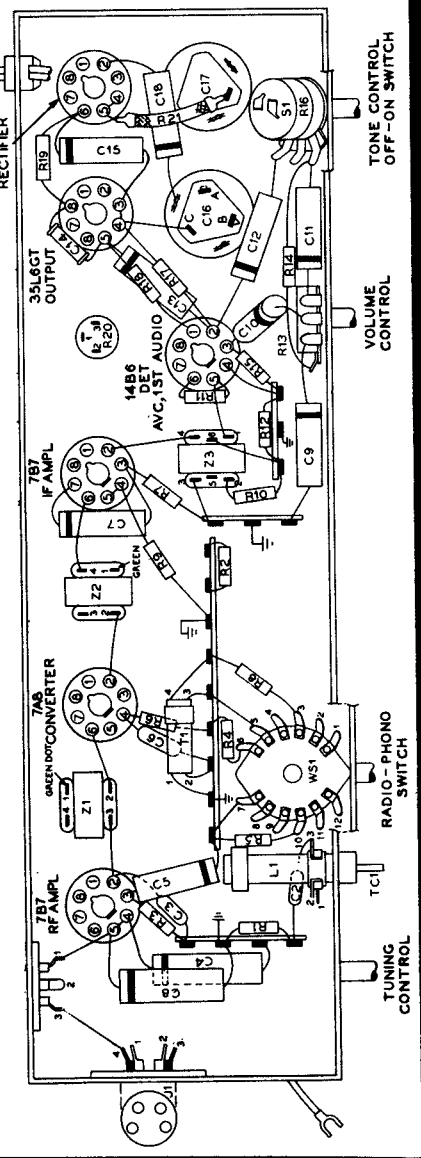
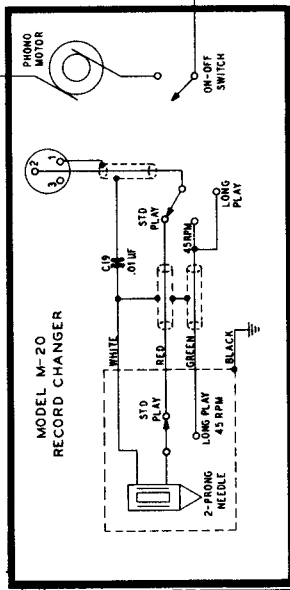

MANUAL OF 1950 MOST-OFTEN-NEEDED RADIO DIAGRAMS

PHILCO RADIO MODEL 51-934

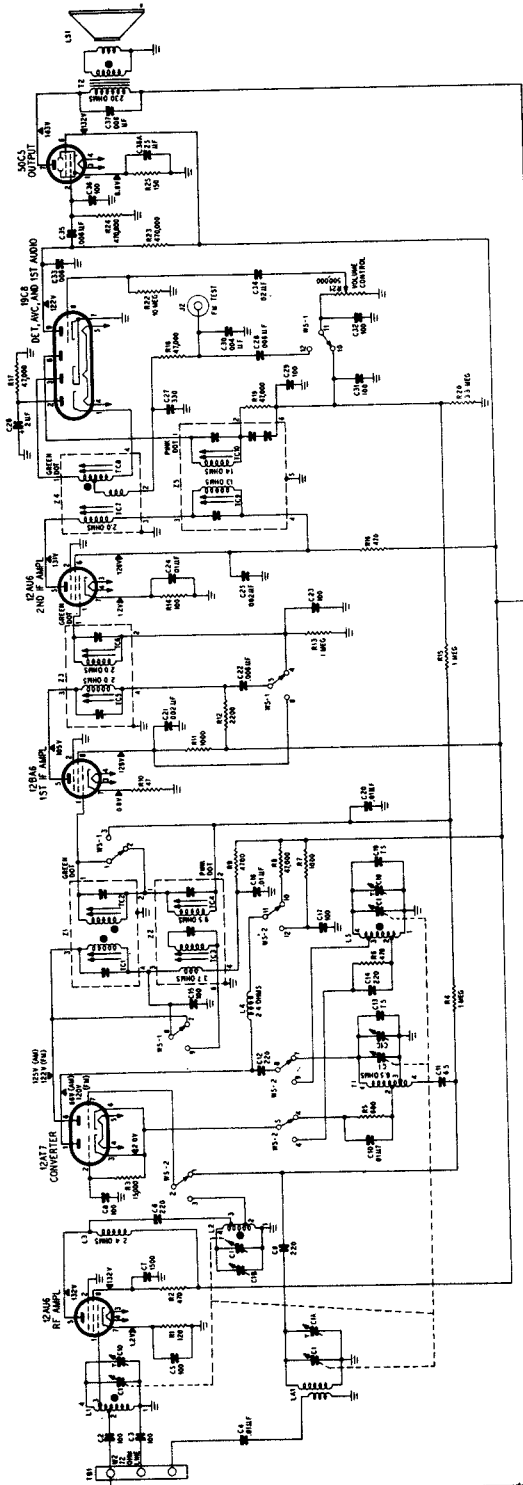

IF (AM) - 455KC
IF (FM) - 21MC

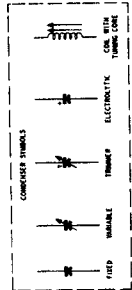

NOTES:
ALL RESISTOR VALUES IN OHMS UNLESS ALL CONDENSER VALUES IN MICROFARADS UNLESS OTHERWISE SPECIFIED.
RESISTOR VALUES IN OHMS UNLESS OTHERWISE SPECIFIED.
RESISTOR VALUES IN OHMS UNLESS OTHERWISE SPECIFIED.
RESISTOR VALUES IN OHMS UNLESS OTHERWISE SPECIFIED.
RESISTOR VALUES IN OHMS UNLESS OTHERWISE SPECIFIED.

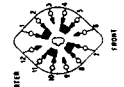
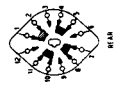

SECTION MARKS ARE SHOWN IN BRACKETED ALPHABETIC LETTERS FROM FRONT WITH CHASSIS NUMBER SECTION OF SWITCHES INDICATED BY 1-1, 1-2, FROM FRONT TO REAR.

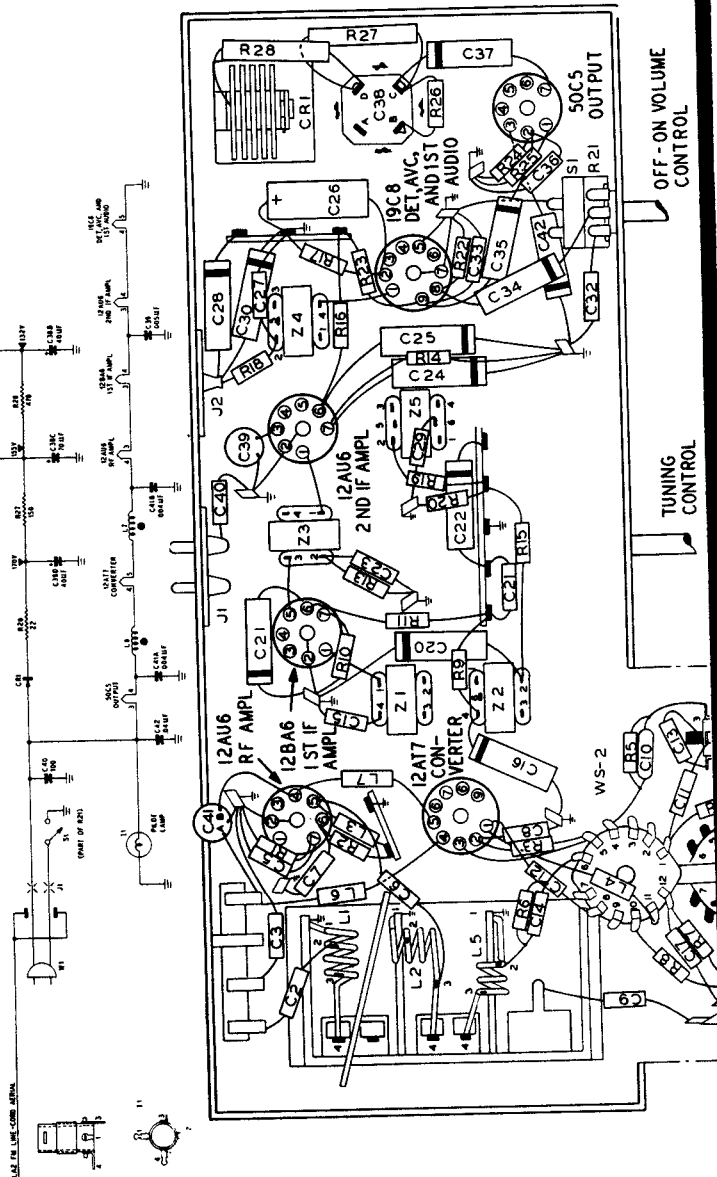

MANUAL OF 1950 MOST-OFTEN-NEEDED RADIO DIAGRAMS

PHILCO RADIO MODEL 51-631

POWER CONSUMPTION

A-C Operation 11 watts
 Battery Operation 9.5 ma. from 67.5-volt "B" battery
 250 ma. from 1.5-volt "A" battery

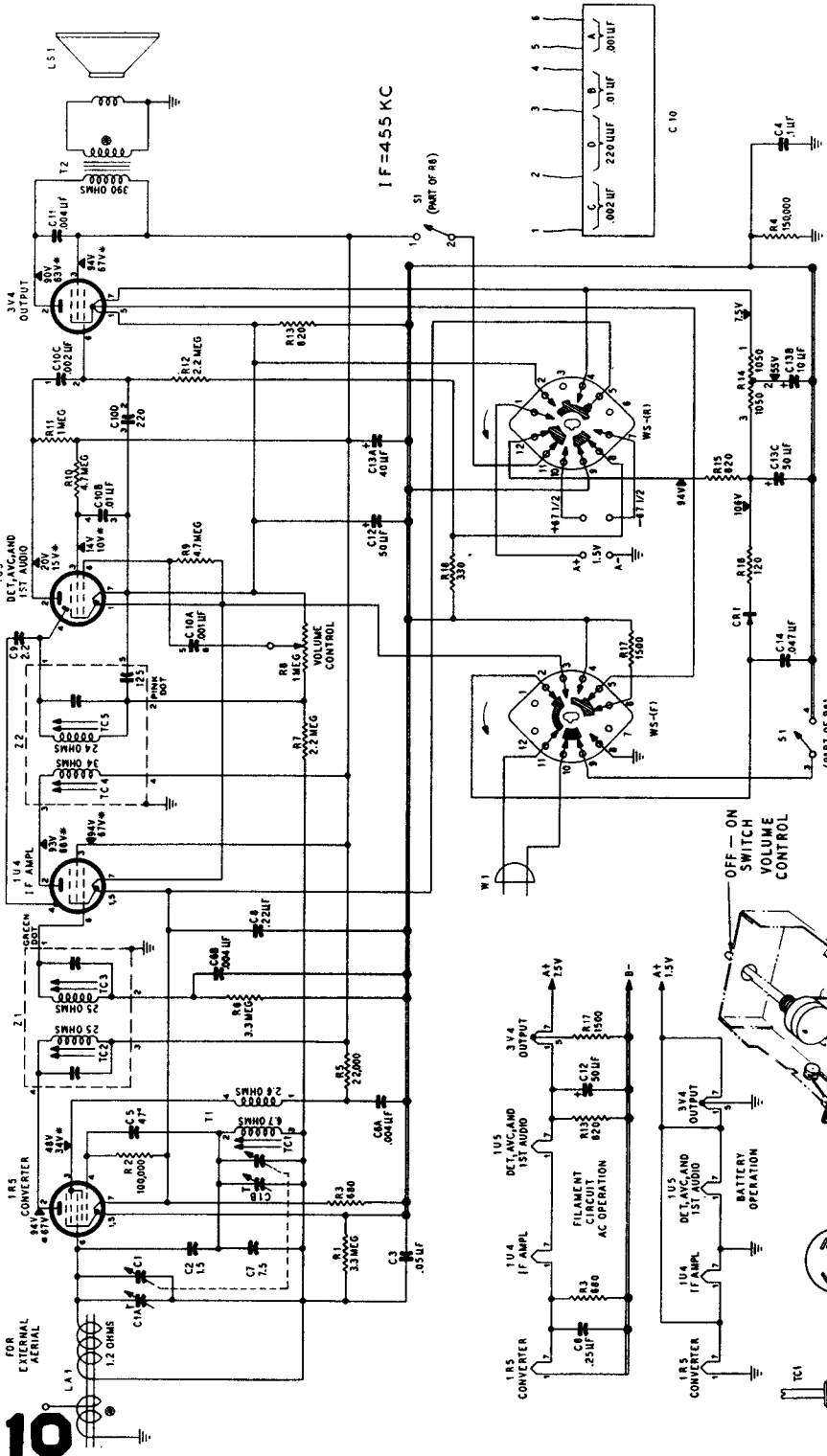

Philco Radio Model 51-631, Schematic Diagram

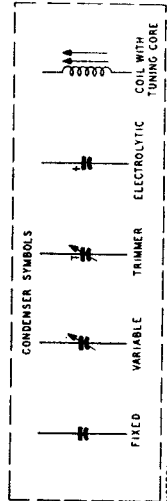

NOTES:
 ALL RESISTOR VALUES IN OHMS AND ALL CONDENSER VALUES IN μ UF UNLESS OTHERWISE MARKED
 * LESS THAN 1 OHM
 ALL VOLTAGES SHOWN WERE MEASURED WITH A 20000 OHMS-PER-VOLT METER FROM POINTS INDICATED TO B-VOLTAGE READINGS IDENTIFIED BY AN ASTERISK (*) ARE FOR BATTERY OPERATION.
 W1 WINDING ARE FOR A-C OPERATION.
 W2 SHOWN IN A-C POSITION.

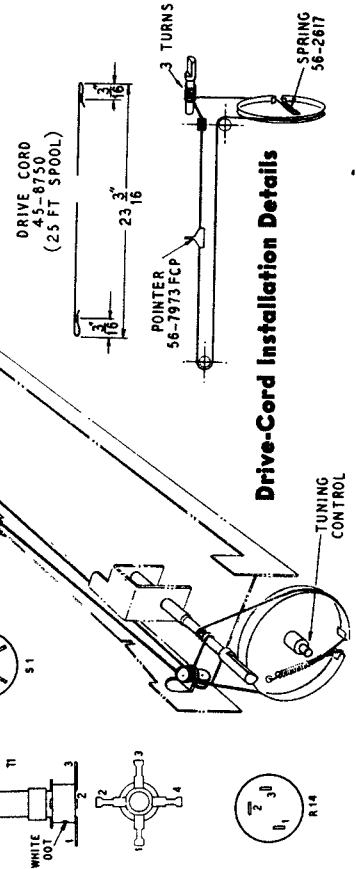

Drive-Cord Installation Details

MANUAL OF 1950 MOST-OFTEN-NEEDED RADIO DIAGRAMS

PHILCO MODEL M-20 ALL-SPEED AUTOMATIC RECORD CHANGER

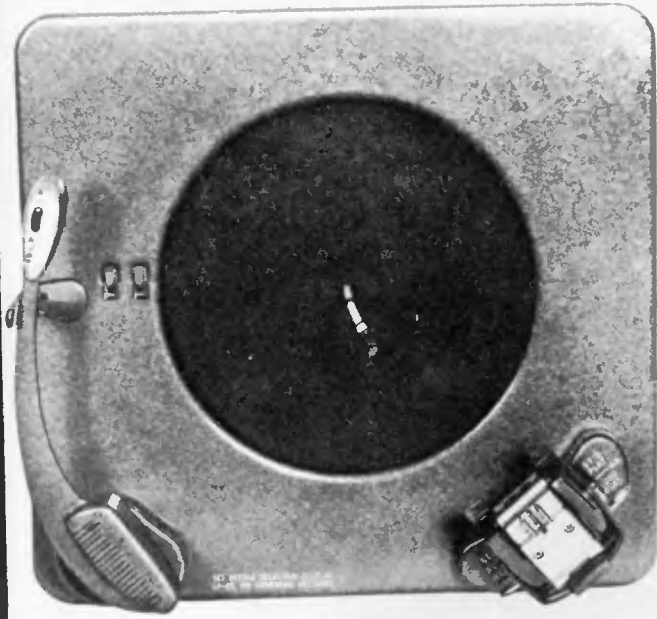

The material on this changer which is used in many Philco combination models begins on this page and continues through page 118. This material is reproduced through the courtesy of the Philco Corporation.

Model M-20



DESCRIPTION OF OPERATIONAL CYCLES

Power for the motor is obtained through the on-off switch mounted on the bridge assembly. This switch is operated manually by the control button with positions OFF-MAN-AUT-REJ. This button is located to the left of the record-shelf assembly, on the top of the Record Changer.

The Record Changer has three speeds, controlled by the Speed Selector located to the right of the record-shelf assembly. The positions of the Speed Selector are STD PLAY- 45 -LONG PLAY. These speed changes are brought about by the shift lever, which changes the positions of the idler wheel and pulley with respect to the motor shaft.

The changer mechanism of the Record Changer is brought into action when a small retractable gear segment, mounted on the cam gear, is released, and engages the hub gear of the turntable shaft, causing the cam gear to be driven. While a record is playing, the retractable gear segment is held in the retracted position by the triplate retaining wall, which engages the roller of the gear segment. The segment is released either manually, by pushing the OFF-MAN-AUT-REJ control to REJ, or automatically, when the changer tone arm reverses direction as the needle follows the eccentric finish groove of a record. For 45 r.p.m. automatic operation, an additional trip mechanism is brought into play. This trip mechanism is actuated by a trip stop, mounted on the trip receiver. When the needle of the tone arm enters the finish groove of a 45 r.p.m. record, the trip stop engages the trip lever, which releases the hammer; this hammer strikes the trip plate, and pushes it aside. The gear segment is then released, as explained above, for either the standard or long-play operations.

The tone arm of the Record Changer is operated by two link assemblies attached to actuator levers, which are in contact with the cam surfaces of the cam gear. When the cam gear starts rotating, the lower actuator lever is pushed outward first, and the link assembly with the long cord attached to it raises the tone arm off the record. As the cam gear continues to turn, the upper actuator lever is pushed outward, and its link assembly pulls the tone arm out against the rest post. At this instant, a roller on the cam gear makes contact with the push-off actuator (which is connected to the record-shelf assembly through a series of push-off bars), and operates the record-dropping mechanism.

After the record has dropped to the turntable, the cam releases the upper actuator, permitting the tone arm to move inward. As the tone arm moves toward the center of the turntable, the index finger engages one of the selectors, which stops the tone-arm travel at a point just above the start groove of the record. Following this action, the lower actuator, which is engaged with the lower cam surface of the cam gear, starts riding inward, relaxing the long cord and link assembly, allowing the tone arm to set down onto the record.

MANUAL OF 1950 MOST-OFTEN-NEEDED RADIO DIAGRAMS

Model M-20



ADJUSTMENTS

INDEXING OR SET-DOWN

7" Record

Set a 7" record on the turntable, push the OFF-MAN-AUT-REJ control to REJ, and rotate the turntable by hand approximately $4\frac{1}{2}$ turns. The tone-arm needle

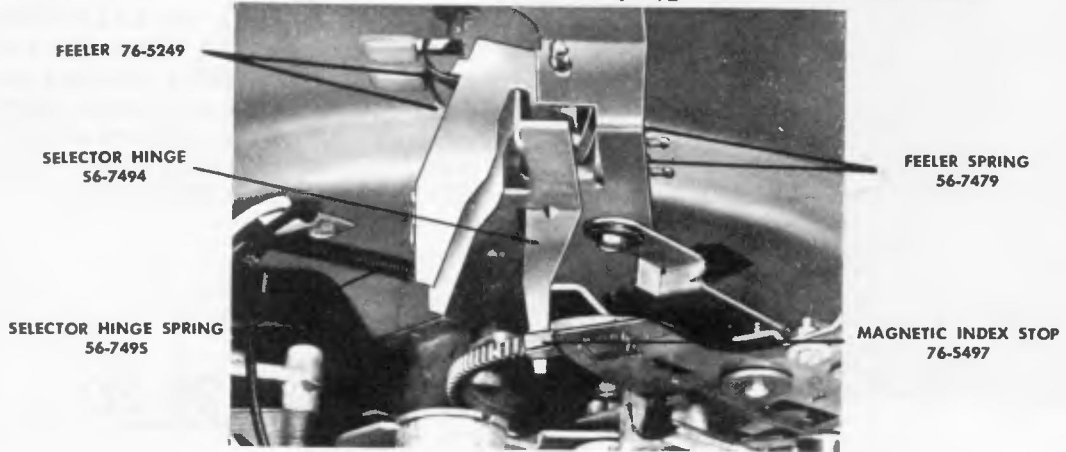

FIGURE 1. 7" INDEX ADJUSTMENT



FIGURE 2. 10" INDEX ADJUSTMENT

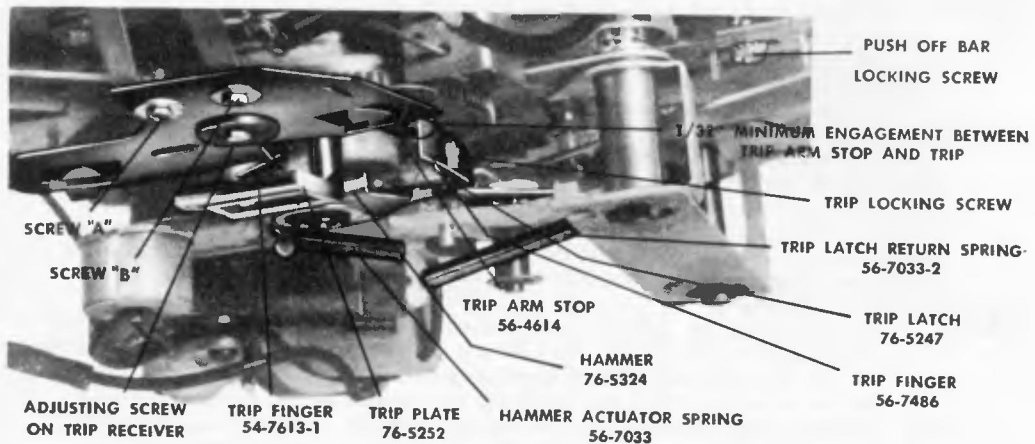

FIGURE 3. TRIP ADJUSTMENTS



should be approximately $\frac{1}{2}$ " above the record at this point. Loosen the clamp screw on the trip arm slightly (figure 9); then hold the tone arm steady, $\frac{1}{8}$ " in from the edge of the record, and set the trip arm so that the magnetic index stop, Part No. 76-5497, is in contact with the selector hinge (inside selector), Part No. 56-7494, as shown in figure 1. The index stop should engage the selector hinge by a minimum of $\frac{1}{8}$ ".

Tighten the clamp screw, leaving $\frac{1}{32}$ " vertical play, or clearance, between the trip arm and the base plate.

10" Record

Make the index adjustment for 7" records first. Check 10" indexing by the same method as that outlined above. With the needle point $\frac{1}{2}$ " above the record, and $\frac{1}{8}$ " in from the outside edge, the index stop should be in contact with the middle selector, Part No. 56-7478, as shown in figure 2.

Ordinarily, the 10" index is satisfactory after the 7" index adjustment is made; if not, bend the selector *slightly* to the right or left, as required, for the proper set-down of the needle.

12" Record

Adjust as given above for 10" records, except that the index stop should contact the outside selector, Part No. 56-7478. If the indexing is incorrect, bend the selector hinge *slightly* to the right or left, as required, for proper set-down.

TRIP ACTION

10" or 12" Standard or Long-Play Records

With a 10" or 12" record on the turntable, the Speed Selector set to either **ST'D PLAY** or **LONG PLAY**, and the **OFF-MAN-AUT-REJ** control in **AUT** position, place the tone arm in the finish, or eccentric, groove of the record. The trip finger, Part No. 56-7486, now rides over the ratchet of the trip plate, Part No. 76-5252, as shown in figure 3. The trip finger should ride at an angle of 25° to 30° with respect to the ratchet. To obtain the correct angle, adjust the screw on the trip receiver, Part No. 56-7491, as indicated in figure 3: Make certain that the vertical center line of the trip finger coincides with the center line of the ratchet. To obtain this alignment, loosen screw "A" slightly, and screw "B" completely, on the trip receiver, and swing the trip receiver to the right or left, rotating about point "A" until the trip finger is centered over the ratchet; then tighten the screws.

When this adjustment is made, care should be taken to prevent the trip receiver from being pulled in toward the trip arm too far, as this will prevent the trip-arm stop from engaging the selector hinge by a minimum of $\frac{1}{8}$ ". A compromise between these two adjustments should be reached.

The index adjustment will be affected when making the above adjustments. Remember that these three adjustments are interrelated, and that, when any one of them is made, the other two should be rechecked.

7" — 45 R.P.M. Records

Place a 7", 45 r.p.m. record, with adaptor insert, on the turntable. Set the Speed Selector to 45, and the **OFF-MAN-AUT-REJ** control to **AUT** position. Set the tone arm on the portion of the record which contains the lead-in grooves. The mechanism should trip when the needle reaches a point approximately $\frac{1}{8}$ " from the last groove (which is concentric). If it trips before reaching this point, bend the trip finger, Part No. 56-7486, away from the trip-arm stop. If it fails to trip when this point is reached, bend in the opposite direction.

The trip-arm stop should engage the trip by a minimum of $\frac{1}{32}$ " in both the horizontal and vertical planes, as shown in figure 3. This may be adjusted by loosening the trip locking screw, and sliding or raising the trip to the desired position.

The horizontal force required to trip the changer and initiate the change cycle should not exceed 2 grams at any turntable speed.

TONE-ARM HEIGHT AND LIFT

With the changer out of cycle, and the tone arm free, set the arm over the base plate. The needle point should be approximately $\frac{3}{16}$ " above the base plate, as shown in figure 4. To adjust the clearance, bend the protruding ear of the swivel post (bending the ear upward increases the clearance, downward decreases the clearance), as shown in figure 5. Now raise the tone arm to its maximum height, and place it against the rest post. There should be a minimum of $\frac{1}{8}$ " clearance between the lower

MANUAL OF 1950 MOST-OFTEN-NEEDED RADIO DIAGRAMS

edge of the tone arm and the top of the rest-post hook. Adjust the ear on the swivel post until a mean is reached between the correct rest-post clearance and base-plate clearance.

TONE-ARM HORIZONTAL AND VERTICAL TIMING

Before making the vertical and horizontal adjustments, make the tone-arm height and lift adjustments described above.

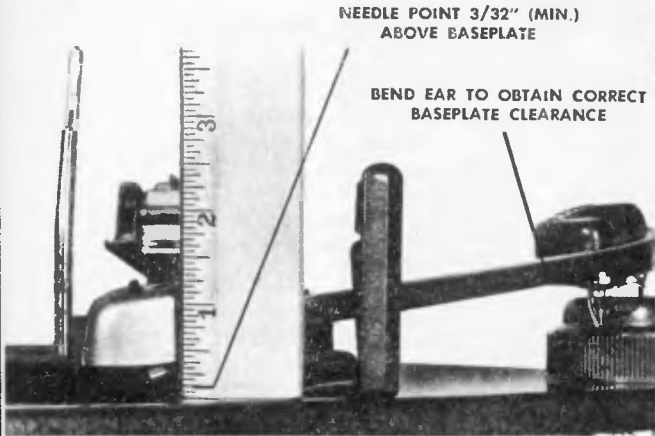

FIGURE 4. BASE-PLATE-CLEARANCE ADJUSTMENT

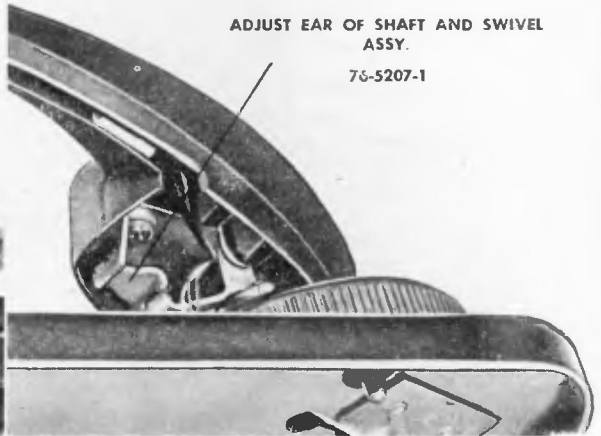

FIGURE 5. TONE-ARM HEIGHT AND LIFT ADJUSTMENT

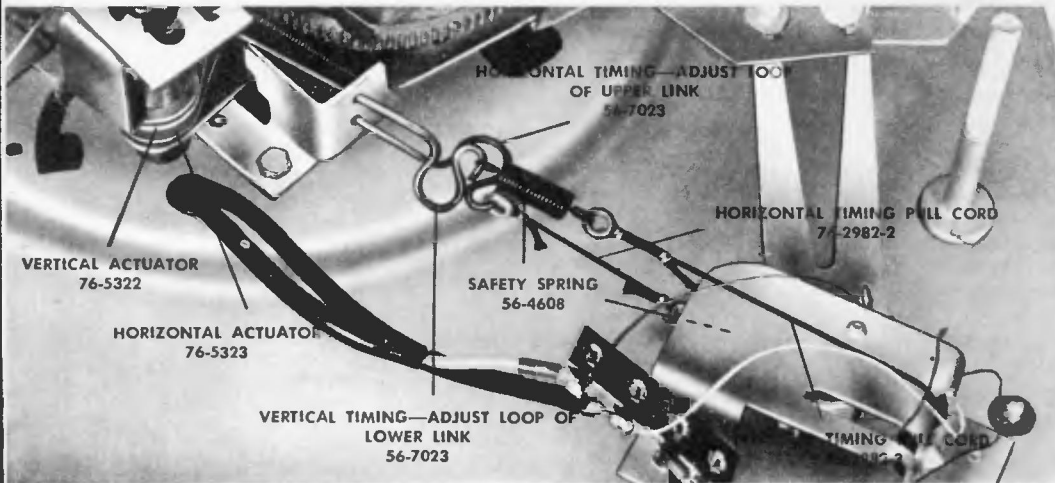

FIGURE 6. HORIZONTAL AND VERTICAL TIMING ADJUSTMENTS



FIGURE 7. SPECIAL RECORD-SHELF GAUGE, SHOWN IN CORRECT POSITION

MANUAL OF 1950 MOST-OFTEN-NEEDED RADIO DIAGRAMS



ADJUSTMENTS (Continued)

Model M-20

For the vertical timing, start with the changer out of cycle and the tone arm on the rest post, push the OFF-MAN-AUT-REJ control to REJ, and rotate the turntable approximately $1\frac{1}{2}$ revolutions by hand. At this point, the lower eccentric portion of the cam-and-gear assembly, Part No. 76-3995-2, fully engages the lower (vertical) actuator (the actuator with the cord), Part No. 76-5322. Adjust the wire loop of the lower link, Part No. 56-7023, figure 6, by squeezing or opening the loop so that the safety spring is expanded approximately $\frac{1}{32}$ ". With this adjustment, the ear of the tone-arm swivel post makes firm contact with the lower end of the cutout on the tone-arm pivot assembly.

For the horizontal timing, start as given in the above paragraph. At the same point, $1\frac{1}{2}$ revolutions from the start of the cycle, the upper eccentric portion of the cam gear fully engages the upper (horizontal) actuator, Part No. 76-5323. Adjust the wire loop of the upper link, Part No. 76-7023, with the short cord, figure 6, by squeezing or opening the loop so that the safety spring is expanded approximately $\frac{1}{32}$ ". With this adjustment, the tone arm should be snug against the rest post, but not so tight as to cause undue slapping as the arm returns to the rest post during cycling.

RECORD SHELF

Set the record shelf to the 10" position, with the changer out of cycle. Loosen the two hex-head drive screws that hold the record-shelf assembly to the changer base plate just sufficiently to allow movement of the record-shelf stanchion. Place the Philco record-shelf gauge, Part No. 45-1672, over the spindle and onto the record shelf, as shown in figure 7. Move the record-shelf assembly away from the spindle until the large, curved part of the gauge drops even with the record-shelf lips. Now push the record shelf and gauge lightly against the spindle, taking out all play toward the spindle; keep the lips of the record shelf in even contact with the edge of the gauge. Tighten the two hex-head screws.

PUSH-OFF

With the changer out of cycle, push the OFF-MAN-AUT-REJ control to REJ, and rotate the turntable 2 revolutions by hand. At this point, the push-off actuator, Part No. 56-4588, is in its most forward position, in contact with the roller on the cam gear. Loosen the push-off-bar locking screw (indicated in figure 3) slightly (just sufficiently to allow adjustment), and squeeze the push-off ears toward each other until the slide plate on the record shelf extends between $\frac{1}{64}$ " and $\frac{1}{32}$ " beyond the lips of the shelf. Tighten the hex-head push-off-bar screw.

NEEDLE PRESSURE

Use the Philco gram scale, Part No. 45-9531. Calibrate the scale to zero by holding it upright for vertical measurement, and setting the pointer to the center line of the scale. The center is the "0" point, and each small division on either side of "0" is equal to one gram.

After the scale has been calibrated to zero, hold the scale perpendicularly to the tone-arm head, and support the tone arm by placing the standard-play needle in the hole at the end of the gram-scale arm, as shown in figure 8. By lifting the gram scale carefully, raise the tone arm approximately $\frac{1}{2}$ ", and note the reading. Then lower the tone-arm, and note the reading. The average of these two readings is the needle pressure, which should be between 7 and 9 grams. The pressure is adjustable by bending the ear at the rear of the tone arm to which the tone-arm spring is anchored, as shown in figure 9. Bending the ear so as to stretch the spring decreases the needle pressure; bending so as to relax the spring increases the needle pressure. If the needle pressure is out of tolerance, make the above adjustments gradually, and recheck after each change, as a small movement gives a rather large variation in needle pressure.

When making this adjustment, be careful not to bend or distort the bracket. If this bracket is deformed, the needle pressure on the last record of a stack will differ from the needle pressure on the first record. When the proper needle pressure is attained, the upper edge of the ear should be parallel to the rear, lower edge of the tone-arm shell. If the bracket was bent while adjusting the ear, gently pry down or push up the bracket (applying even pressure on both sides) until the ear and tone-arm shell are in proper relationship.

MANUAL OF 1950 MOST-OFTEN-NEEDED RADIO DIAGRAMS

Model M-20



ADJUSTMENTS (Continued)

VERTICAL FRICTION

To measure the vertical friction, take two gram-scale readings as explained above under **NEEDLE PRESSURE**. One-half of the difference between the two readings is the vertical friction, which should not exceed 1.5 grams.



FIGURE 8. MEASURING VERTICAL FRICTION

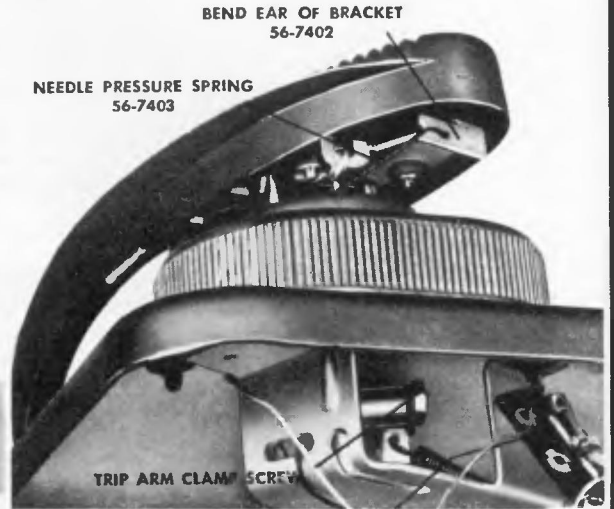

FIGURE 9. NEEDLE-PRESSURE ADJUSTMENT



FIGURE 10. MEASURING HORIZONTAL FRICTION

HORIZONTAL FRICTION

Calibrate the gram scale by laying it flat, face-up. Set the pointer to zero (center mark).

Place a counterweight on top of the rear end of the tone arm, with the changer out of cycle; move the counterweight until the tone arm is balanced horizontally, and the needle point clears the turntable. Hold the gram scale face-up, place its pointer against the side of the pickup, and slowly move the gram scale so as to push the tone-arm horizontally with the pointer, as shown in figure 10. Note the reading of the gram scale while moving the tone arm throughout its entire travel (outside the trip range). At no time should the horizontal friction (the force required to move the tone arm) exceed $1\frac{1}{2}$ grams, nor be less than $\frac{3}{4}$ of a gram.

Note: Whenever any repairs or replacements are performed, all adjustments should be checked, and any necessary adjustments made. When making adjustments, check the lubrication at all points indicated in the LUBRICATION section, and lubricate where necessary, after cleaning off old and excess grease with a soft brush and carbon tetrachloride.

UNEVEN TURNTABLE SPEED (WOWS)

Uneven turntable speed may be caused by the following conditions.

1. Dirt under and around the idler-wheel assembly.
2. Idler-wheel spring loose or missing.
3. Flat spot on idler-wheel tire or on turntable.
4. Loose or worn pulley belt.
5. Oil or grease on idler-wheel tire, pulley, or drive shaft.

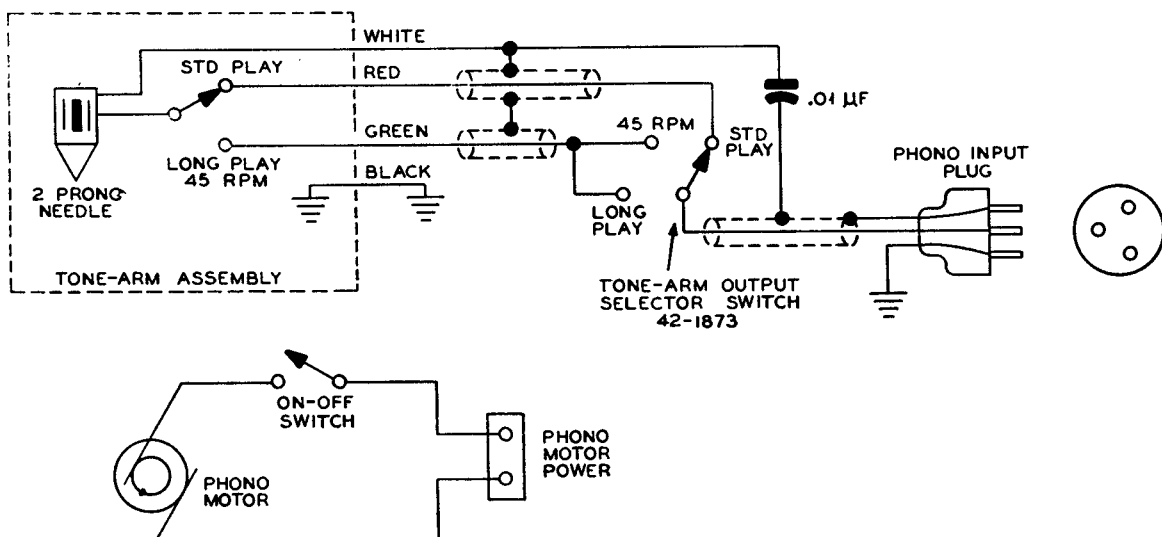

WIRING DIAGRAM OF MODEL M-20



LUBRICATION

When the Record Changer is brought in for service, it should be well cleaned with a fine brush and carbon tetrachloride. Remove the needle guard and clean out accumulated dust with a fine brush. Remove all dirt and old grease and oil. When applying new grease and oil, use it sparingly. Lubrication points are shown in figures 11 and 12. It may be necessary to remove some parts and assemblies in order to properly lubricate them. For example, the cam gear and actuator levers should be removed to lubricate the cam-gear spindle and the actuator stud.

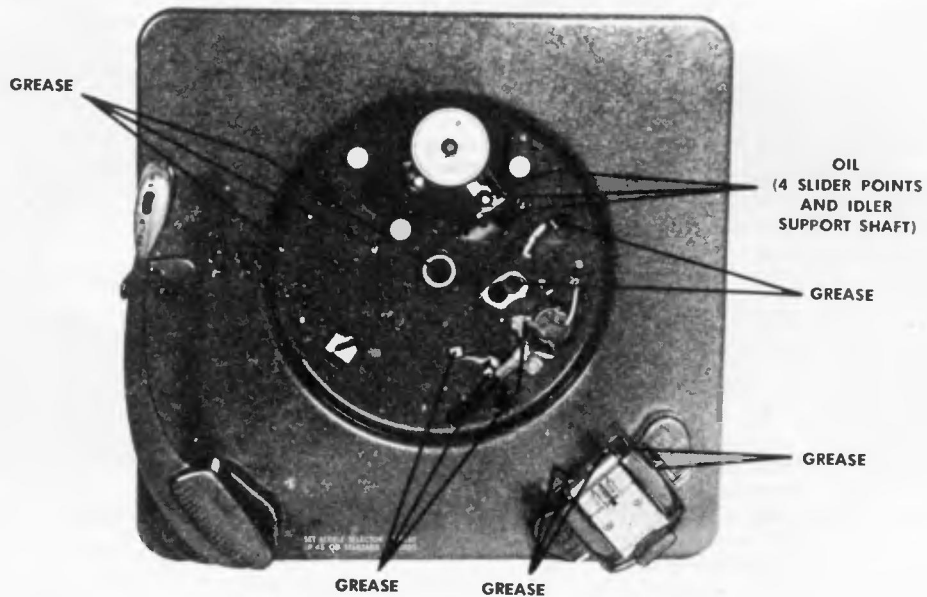

FIGURE 11. TOP VIEW, SHOWING LUBRICATION POINTS

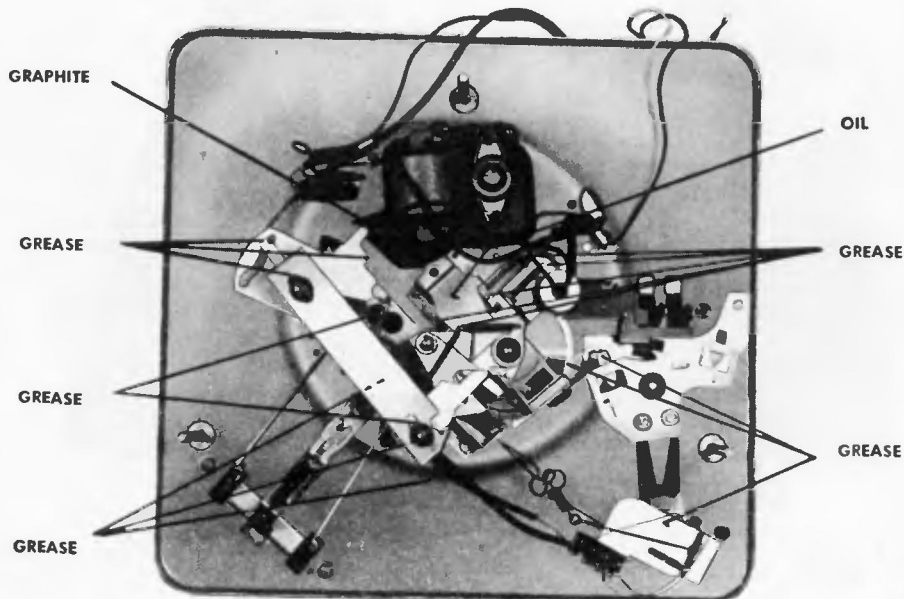
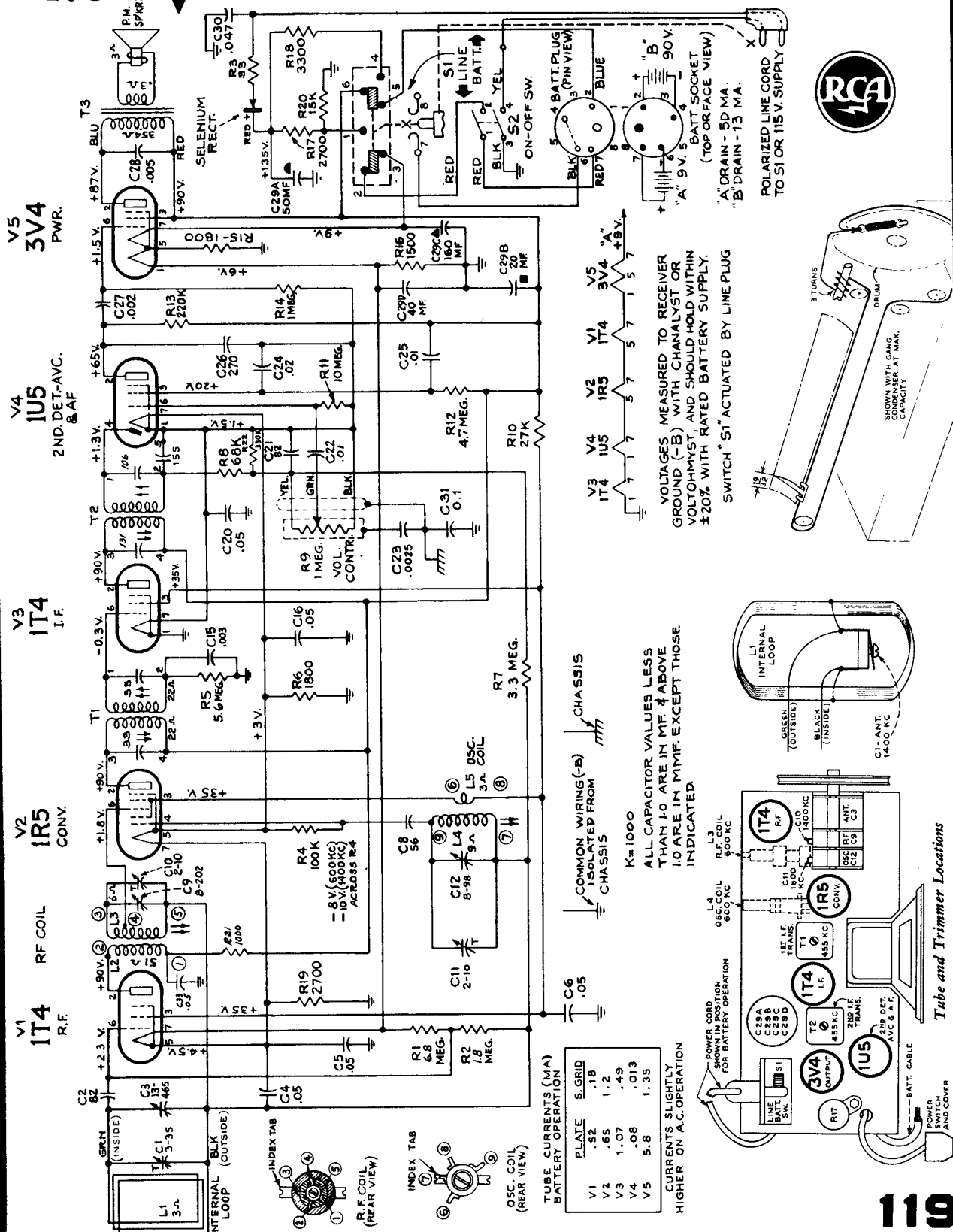

FIGURE 12. BOTTOM VIEW, SHOWING LUBRICATION POINTS

MANUAL OF 1950 MOST-OFTEN-NEEDED RADIO DIAGRAMS

RCA VICTOR MODEL BX6

Chassis No. RC-1082



V5
3V4
PWR.

V4
1U5
2ND.DET.-AVC.
& A.F.

V3
1T4
I.F.

V2
1R5
CONV.

V1
1T4
R.F.

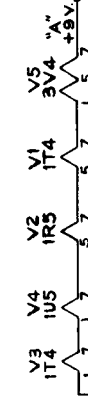

VOLTAGES MEASURED TO RECEIVER GROUND (-B) WITH CHANNELYST OR VOLTOHMMYST, AND SHOULD HOLD WITHIN ±20% WITH RATED BATTERY SUPPLY. SWITCH "S1" ACTUATED BY LINE PLUG

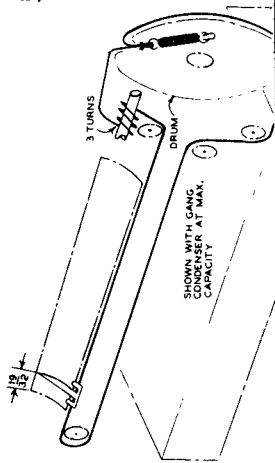

COMMON WIRING (-B) ISOLATED FROM CHASSIS

K=1000
ALL CAPACITOR VALUES LESS THAN 1.0 ARE IN MUF & ABOVE 1.0 ARE IN MMF. EXCEPT THOSE INDICATED

TUBE CURRENTS (MA) BATTERY OPERATION

PLATE	S.GRID
V1	.52
V2	.65
V3	1.07
V4	.08
V5	5.8

CURRENTS SLIGHTLY HIGHER ON A.C. OPERATION

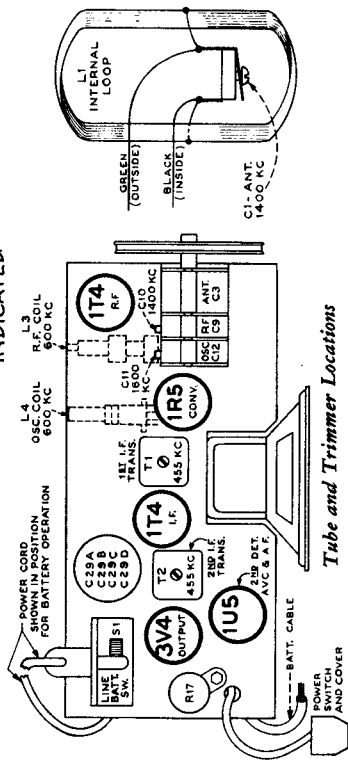

Tube and Trimmer Locations

MANUAL OF 1950 MOST-OFTEN-NEEDED RADIO DIAGRAMS

APPROXIMATE GAIN DATA USING CHANNELIST

18 X 400 ~

80 X 400 ~

8 X 455 KC

170 X 455 KC

7.8 X 455 KC

70 X 800/455 KC

2.2 X 600 KC

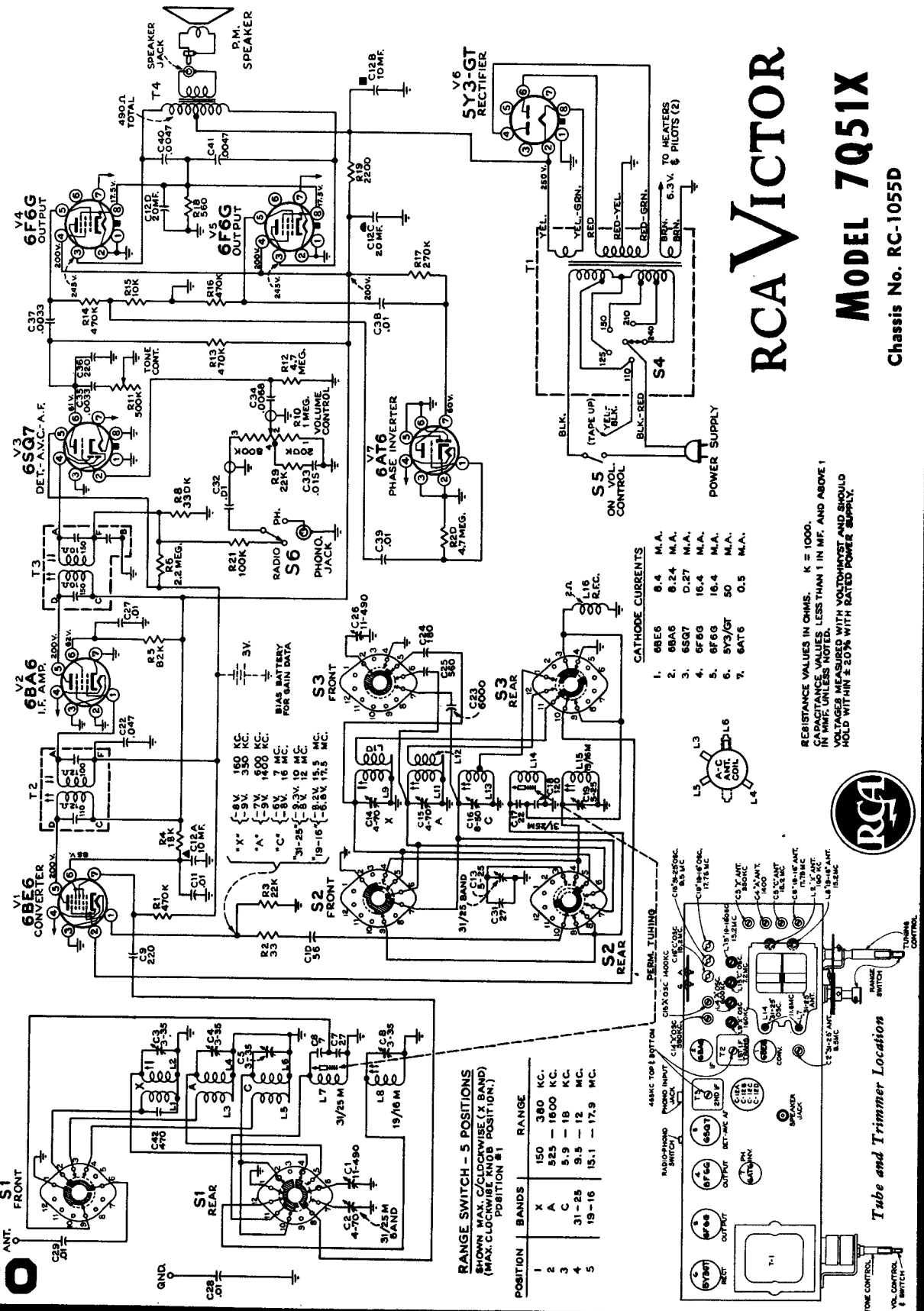

RANGE SWITCH - 5 POSITIONS
 SHOWN MAX. CLOCKWISE (X BAND)
 (MAX. CLOCKWISE KNOB POSITION.)

POSITION	BANDS	RANGE
1	X	150 - 380 KC.
2	A	525 - 1600 KC.
3	C	5.9 - 18 KC.
4	31-25	9.5 - 12 MC.
5	19-16	15.1 - 17.9 MC.

- CATHODE CURRENTS**
- 1. 6BE6 9.4 M.A.
 - 2. 6BA6 6.24 M.A.
 - 3. 6SQ7 0.27 M.A.
 - 4. 6F6G 16.4 M.A.
 - 5. 6F6G 16.4 M.A.
 - 6. 5Y3/GT 50 M.A.
 - 7. 6AT6 0.5 M.A.

RESISTANCE VALUES IN OHMS. K = 1000.
 CAPACITANCE VALUES LESS THAN 1 IN MF. AND ABOVE 1
 IN MMF. UNLESS NOTED.
 VOLTAGES MEASURED WITH VOLTOHMST AND SHOULD
 HOLD WITHIN ± 20% WITH RATED POWER SUPPLY.



RCA VICTOR

MODEL 7Q51X

Chassis No. RC-1055D

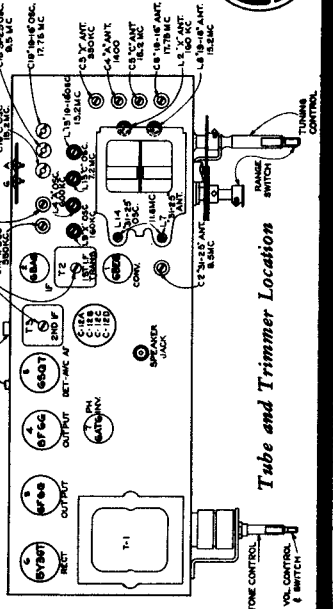

Tube and Trimmer Location

MANUAL OF 1950 MOST-OFTEN-NEEDED RADIO DIAGRAMS

RCA VICTOR 8BX5, 8BX54, 8BX55 Chassis RC-1059A

—2nd. Production

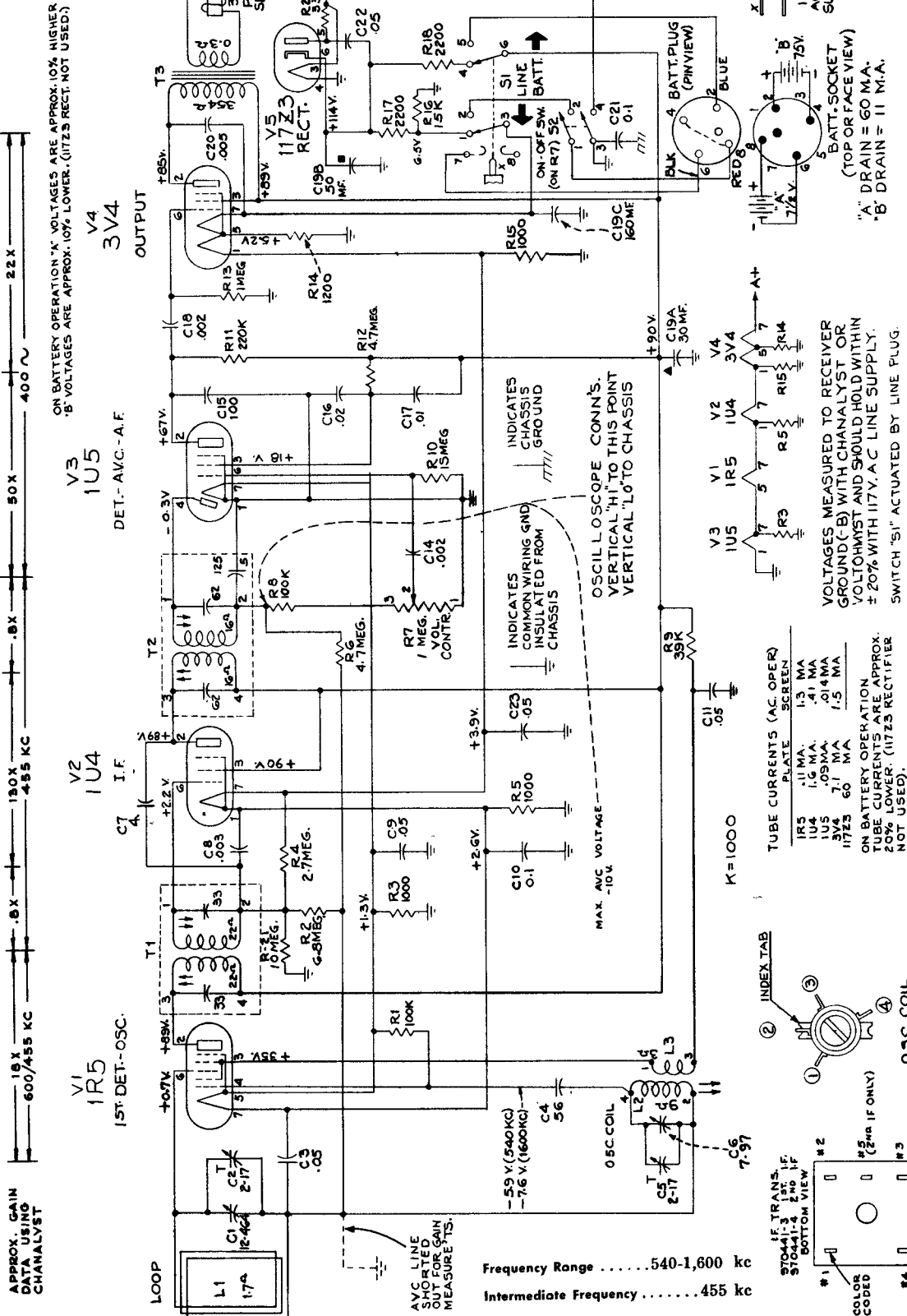

RC-1059A — SCHEMATIC DIAGRAM — 2nd. Production



Model 9BX5, Chassis RC-1059B and -C, are similar to circuit illustrated.

The position of the battery pack affects the loop inductance. Therefore, when the battery is removed, the loop inductance will change (increase) and the sensitivity will be slightly worse because of improper electrical tracking of the loop circuit with the heterodyne oscillator.

RCA VICTOR

Battery Personal Receiver

MODELS 8B41, 8B42, 8B43

Chassis No. RC-1069, RC-1069A, RC-1069B

Alignment Procedure

Output Meter.—Connect meter from top lug of TB5 (plate of 3S4) to ground. Turn volume control to maximum position.

Test-Oscillator.—For all alignment operations, connect the low side of the test-oscillator to the receiver chassis, and keep the oscillator output as low as possible to avoid a-v-c action.

Alignment Shield.—It is necessary to use a shield during oscillator alignment.

Fig. 3 shows the modifications necessary to convert the center strip portion of a case into a convenient shield to be used as a substitute for the regular case center strip during oscillator alignment.

If a substitute case is not available, a shield may be improvised using a sheet of aluminum (DO NOT USE STEEL) to approximate the shielding effect of the case on the 1R5 tube, tuning condenser and oscillator coil.

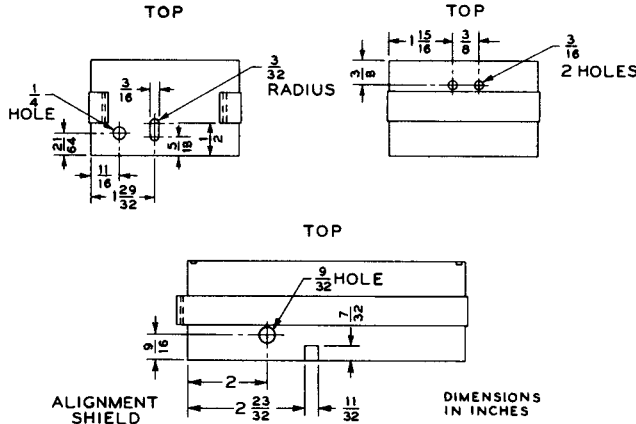
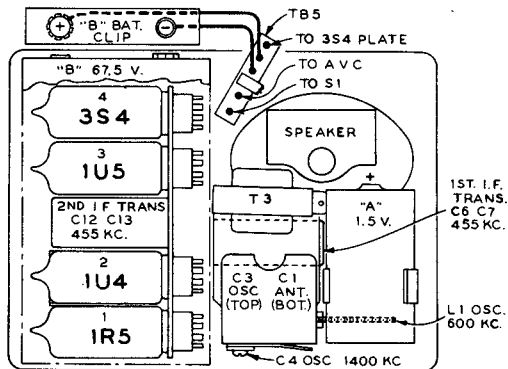

Fig. 3—Alignment Shield



A rubber band should be placed around each tube for cushioning.

Fig. 5—Tube and Trimmer Locations

Steps	Connect the high side of test osc. to—	Tune test-osc. to—	Turn radio dial to—	Adjust the following for max. peak output—
1		455 kc	Quiet point near 1,600 kc	C12, C13 2nd I-F trans.
2	Connection lug of C1 located on rear of gang in series with .01 mf.			C6, C7 1st I-F trans.
3	Repeat steps 1 and 2			
4		1,400 kc	14 Rock gang	C4 (osc.) †
5	*Antenna coupling loop	600 kc	60 Rock gang	L1 (osc.) †
6	Repeat steps 4 and 5			

*Steps 4 and 5 require a coupling loop from the signal generator to feed a signal into the receiver loop located in the lid. This loop should be loosely coupled to the receiver loop antenna so as not to disturb the receiver loop inductance.

† ALIGNMENT SHIELD MUST BE USED. (See text.)

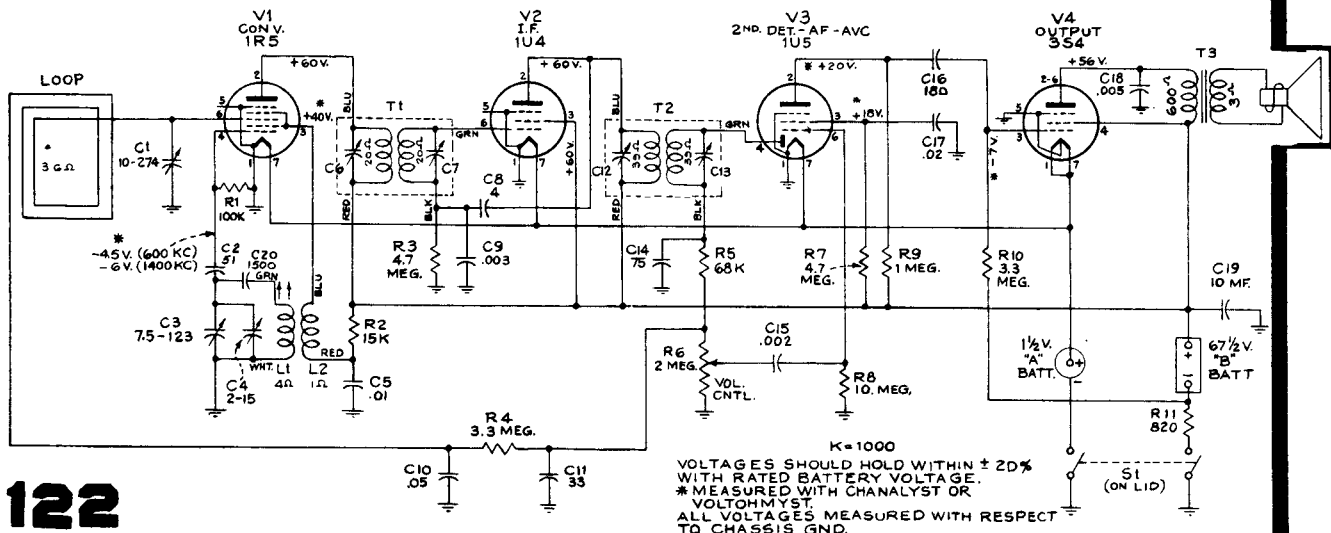

K=1000
VOLTAGES SHOULD HOLD WITHIN ± 20% WITH RATED BATTERY VOLTAGE.
* MEASURED WITH CHANALYST OR VOLTOHMYST.
ALL VOLTAGES MEASURED WITH RESPECT TO CHASSIS GND.

MANUAL OF 1950 MOST-OFTEN-NEEDED RADIO DIAGRAMS

RCA VICTOR

MODEL 9BX56

Chassis No. RC-1068

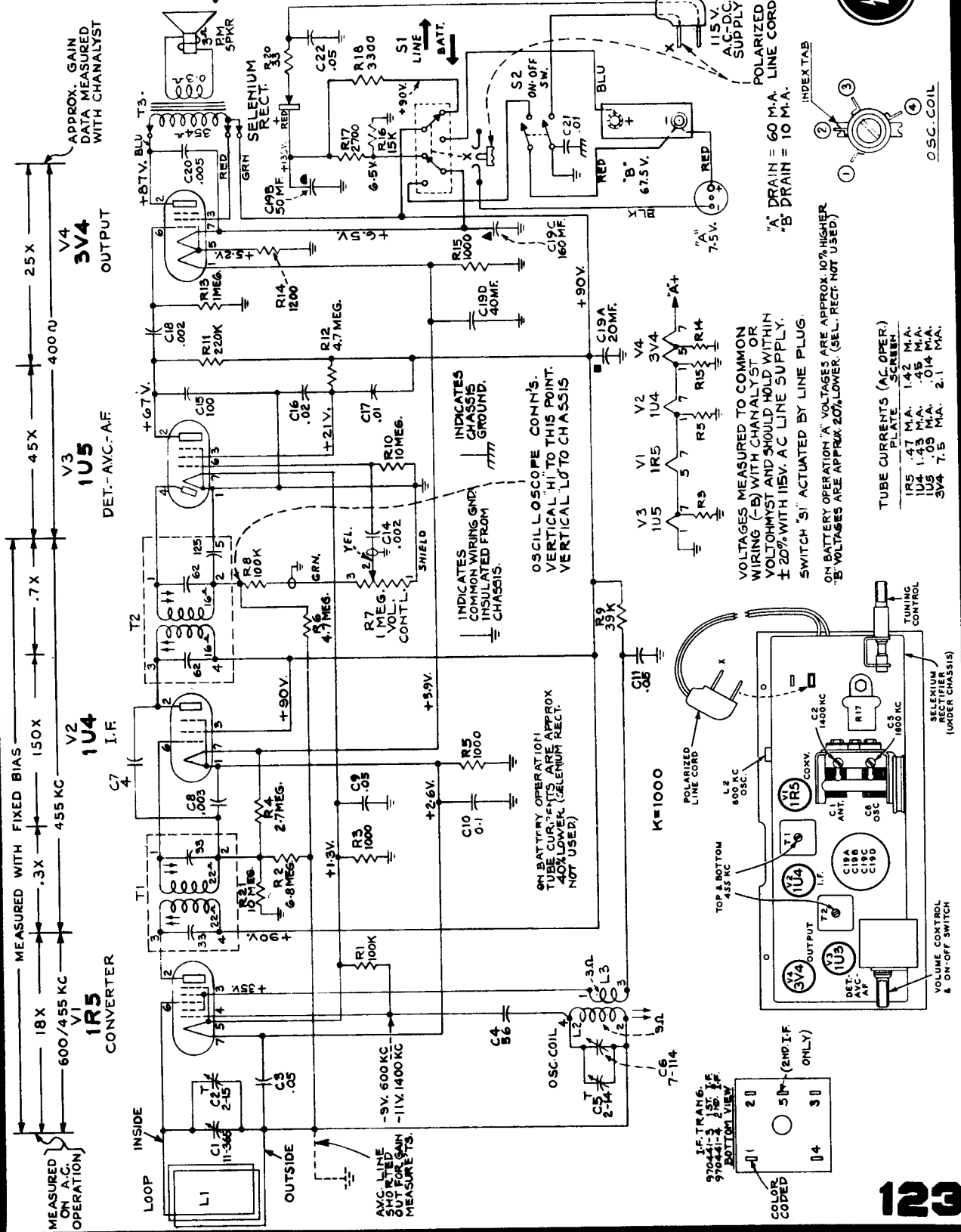

MANUAL OF 1950 MOST-OFTEN-NEEDED RADIO DIAGRAMS

RCA VICTOR

AC-DC Radio Receiver

MODELS 9X561, 9X562

Chassis No. RC-1079-B RC-1079-C

Lead Dress

1. Dress all heater leads down to chassis and away from all audio grid and plate wiring.
2. Dress power cord down to chassis base and corner.
3. Dress capacitor C18 against back apron.
4. Dress capacitor C13 down to base alongside of shielded lead.
5. Dress output transformer leads down to chassis.
6. Dress capacitors C9 and C15 as direct as possible.
7. Dress dial lamp leads on top of chassis between 12SQ7 and 50L6GT tubes; below chassis, as short as possible to rectifier socket.
8. Dress excess loop leads away from tubes and clear of tuning condenser.

Dial Calibration

With the tuning condenser fully meshed, the dial pointer should be set to the first score mark at the left-hand end of the dial back plate. The four score marks represent: Max. cap. 600 kc 1400 kc min. cap.

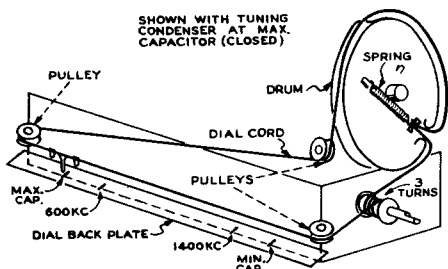

Dial Indicator and Drive Cord

Alignment Procedure

Test-Oscillator.—For all alignment operations, connect the low side of the test-oscillator to the receiver chassis, and keep the oscillator output as low as possible to avoid a-v-c action.

On AC operation an isolation transformer (115 v./115 v.) may be necessary for the receiver if the test oscillator is also AC operated.

Steps	Connect the high side of test-oscillator to—	Tune test-osc. to—	Turn radio dial to—	Adjust the following for max. output
1	12SK7 I-F grid through 0.1 mfd. capacitor	455 kc	Quiet-point 1600 kc end of dial	T2 (top and bottom) 2nd I-F trans.
2	Stator of C1 through 0.1 mfd.			*T1 (top and bottom) 1st I-F trans.
3	Short wire placed near loop to radiate signal	1620 kc	Min. cap.	C4 (osc.)
4		1400 kc	1400 kc	†C2 (ant.)
5		600 kc	600 kc	L3 (osc.) Rock gang
6	Repeat steps 3, 4 and 5.			

*Do not readjust T2 when test oscillator is connected to C1.

†When adjusting C2 (ant. trimmer) it is necessary to have the loop in the same position and spacing as it will have when assembled in the cabinet.

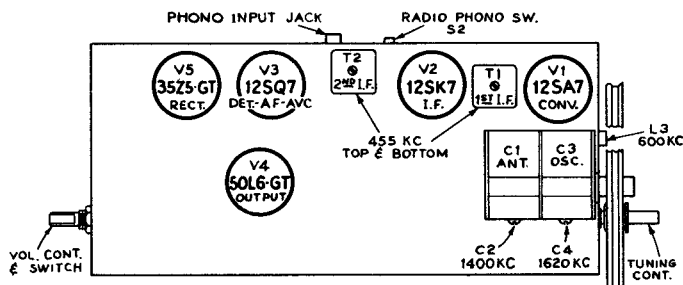

Tube and Trimmer Locations

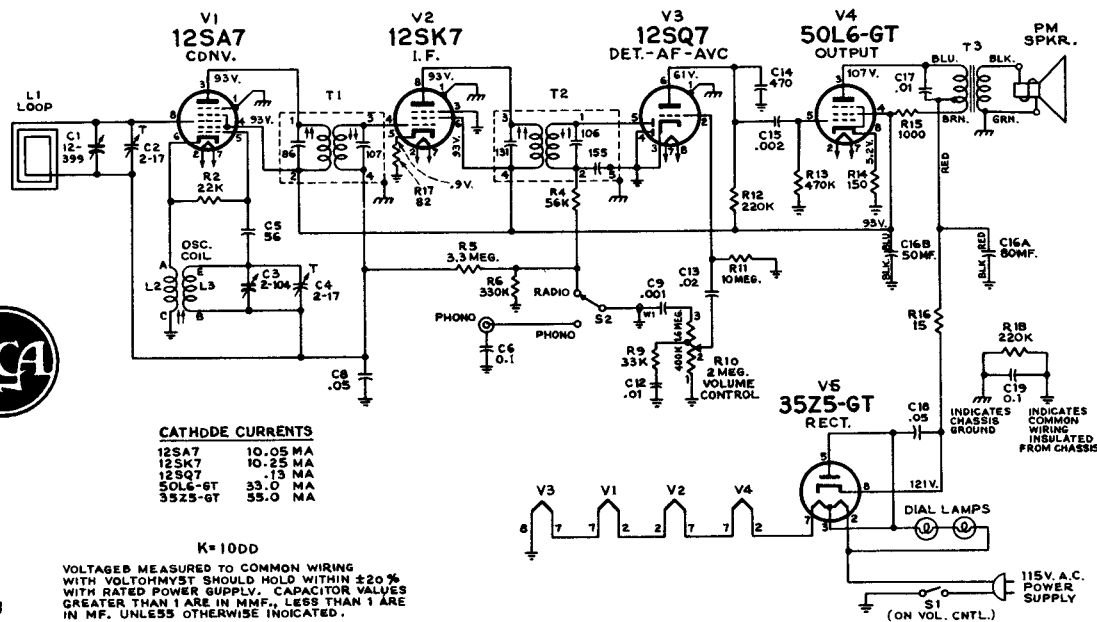

CATHODE CURRENTS

12SA7	10.05 MA
12SK7	10.25 MA
12SQ7	13 MA
50L6-GT	33.0 MA
35Z5-GT	55.0 MA

K=10DD

VOLTAGES MEASURED TO COMMON WIRING WITH VOLTOHMYST SHOULD HOLD WITHIN ±20% WITH RATED POWER SUPPLY. CAPACITOR VALUES GREATER THAN 1 ARE IN MMF., LESS THAN 1 ARE IN MF. UNLESS OTHERWISE INDICATED.



MANUAL OF 1950 MOST-OFTEN-NEEDED RADIO DIAGRAMS

RCA VICTOR

MODELS 9X641, 9X642

Chassis No. RC-1080 RC-1080A

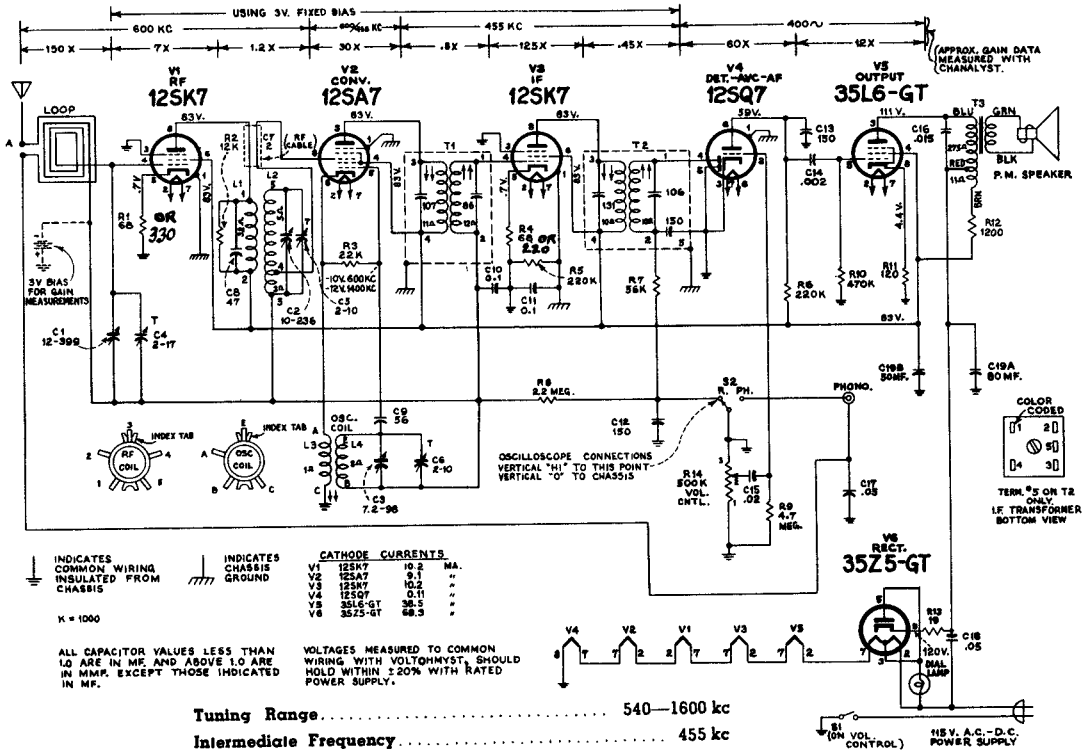

In some chassis an alternate filter capacitor is used which has three sections. The low voltage section (20 mf. 25 volts) is not used. The alternate capacitor is mounted on top of the chassis and is available as Stock No. 73975.

RCA VICTOR

MODELS 9X571, 9X572

Chassis No. RC-1079 RC-1079A

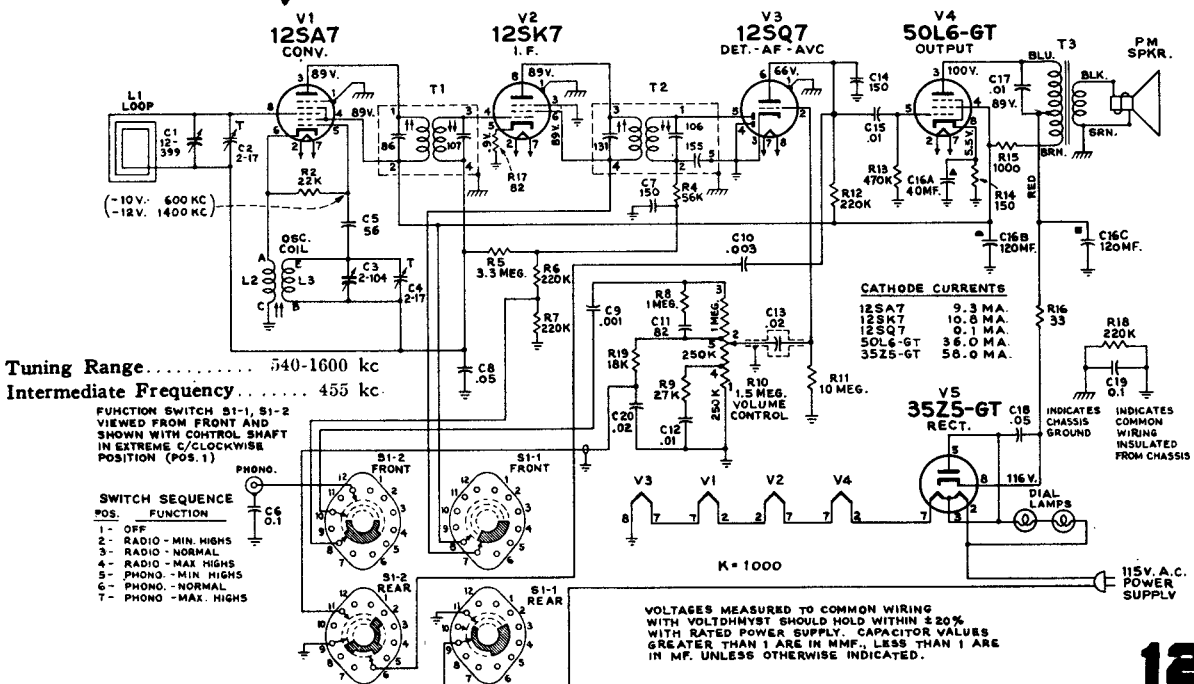

RCA VICTOR

MODELS 9X651, 9X652

Chassis No. RC-1085 RC-1085A

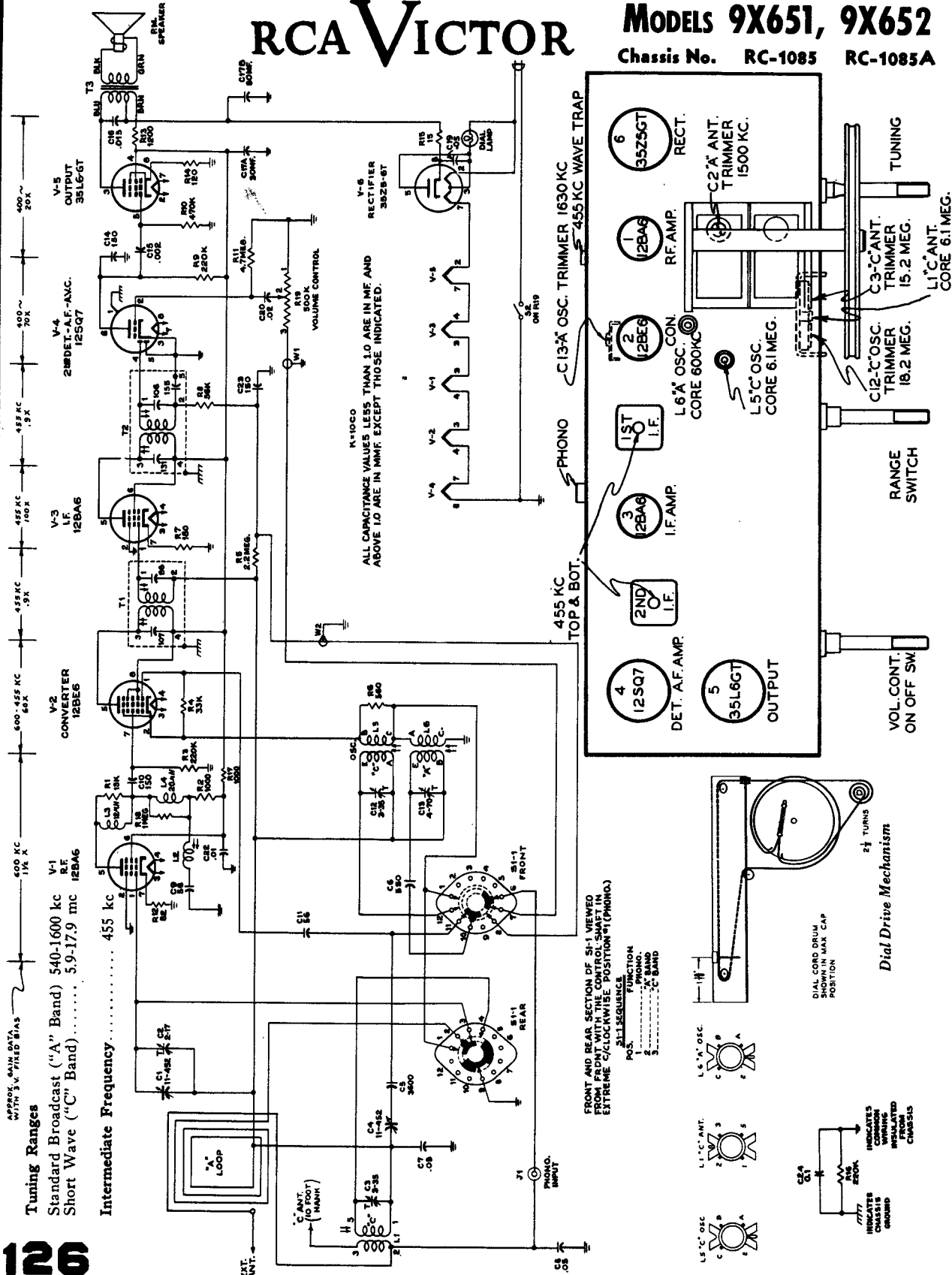

MANUAL OF 1950 MOST-OFTEN-NEEDED RADIO DIAGRAMS

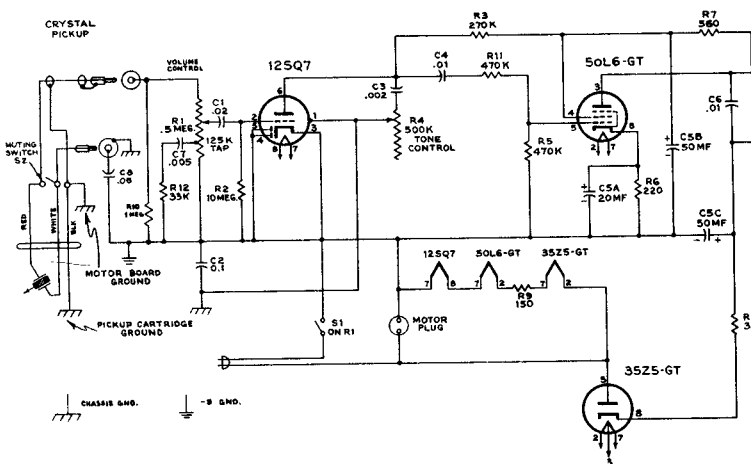

RCA VICTOR
MODELS 9EY31, 9EY32
 Portable 45 RPM
 Record Player

RCA VICTOR

Automatic Record Player

Automatic Record Player

MODEL 9EY3, 9EY35, 9EY36

Chassis No. RS-132

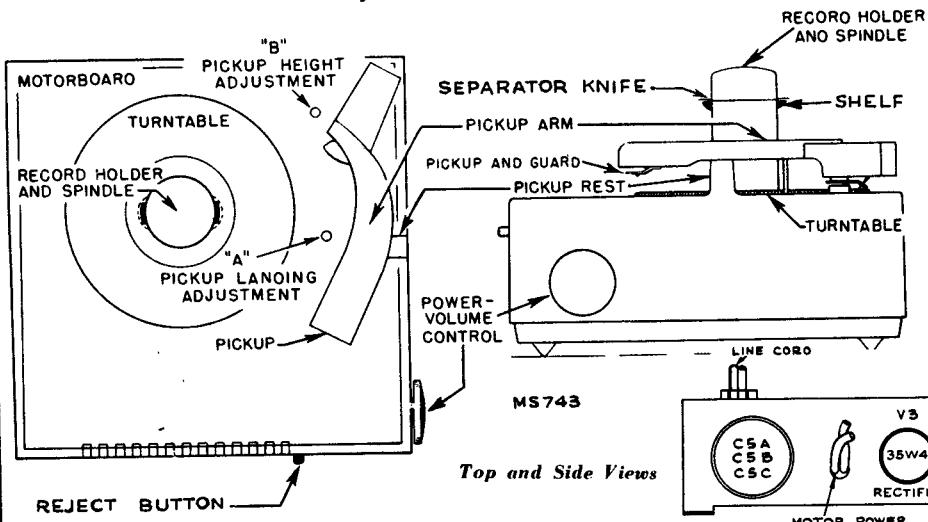

CATHODE CURRENTS	
12AV6	0.19 MA
50C5	49.3 MA
35W4	49.7 MA

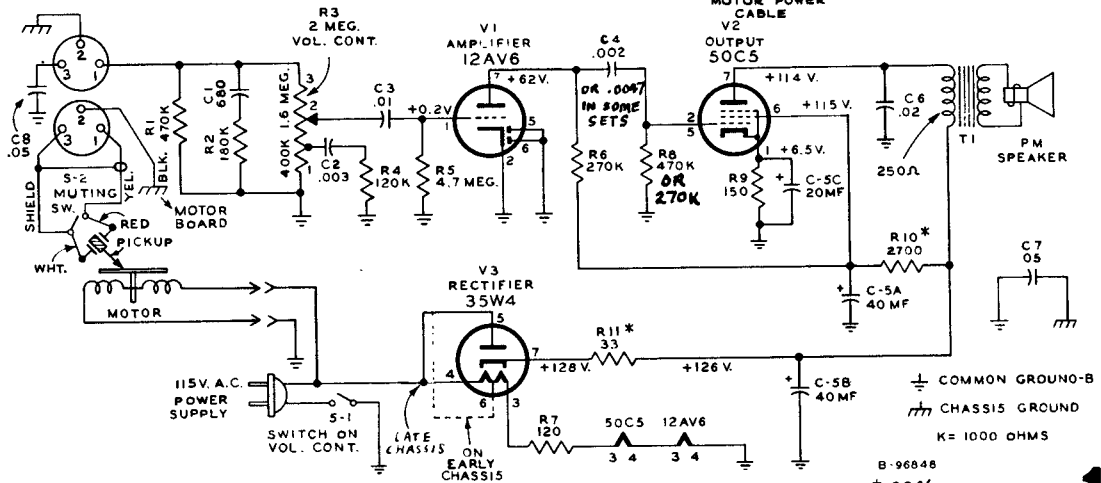
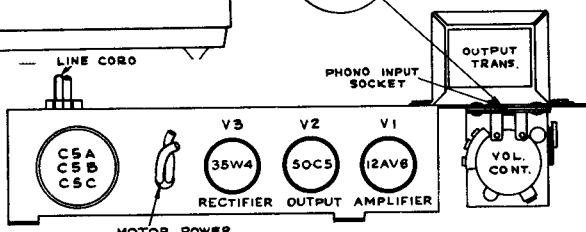

VOLTAGES MEASURED TO COMMON WIRING WITH "VOLTOHMYST" - SHOULD HOLD WITHIN ± 20%
 * IN SOME CHASSIS R10 IS 5600 OHMS, R11 IS NOT USED, RECTIFIER CIRCUIT AS SHOWN BY DOTTED LINE

MANUAL OF 1950 MOST-OFTEN-NEEDED RADIO DIAGRAMS

RCA

MODEL 9Y7

Chassis No. RC-1057B

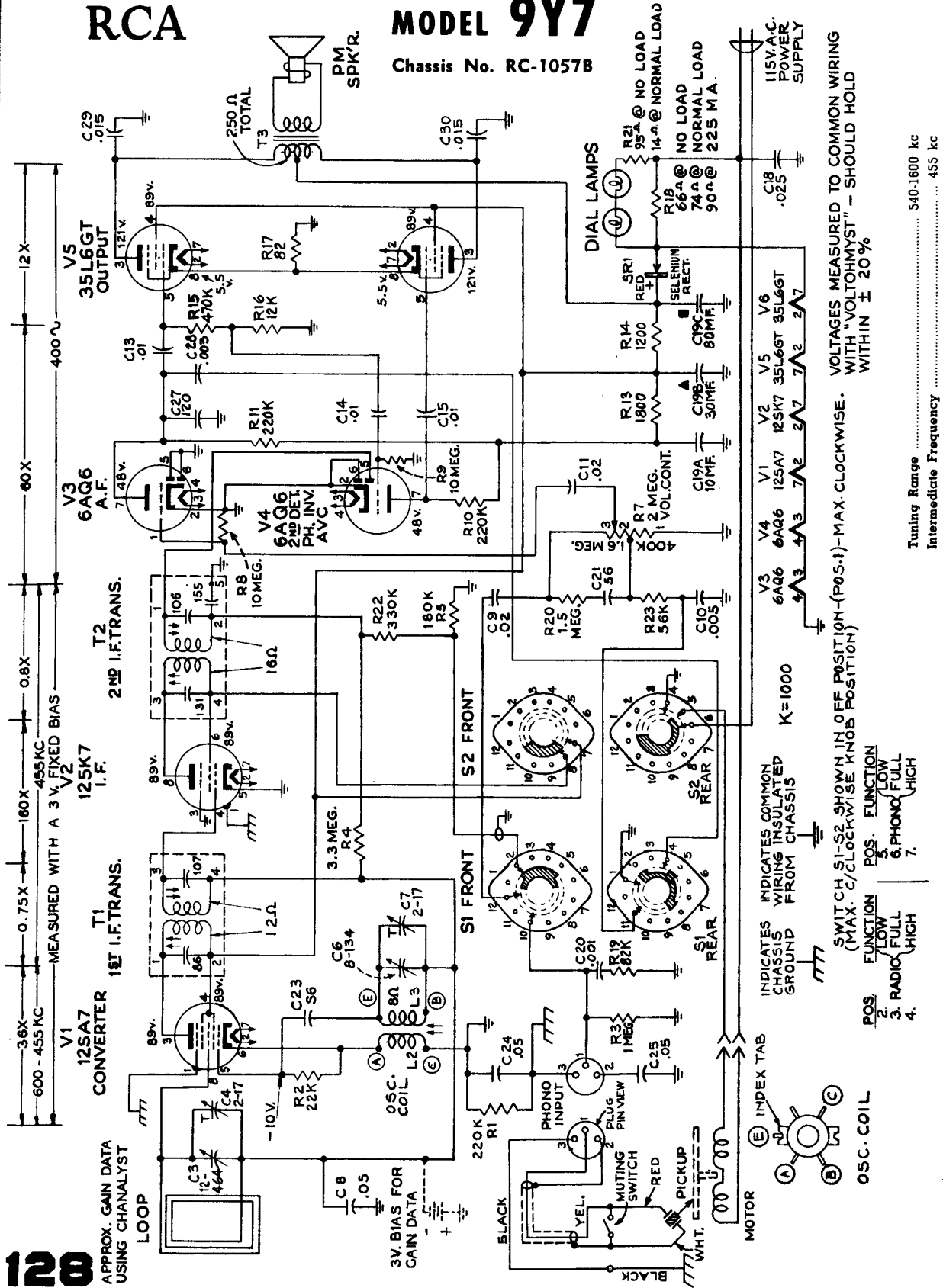

MANUAL OF 1950 MOST-OFTEN-NEEDED RADIO DIAGRAMS

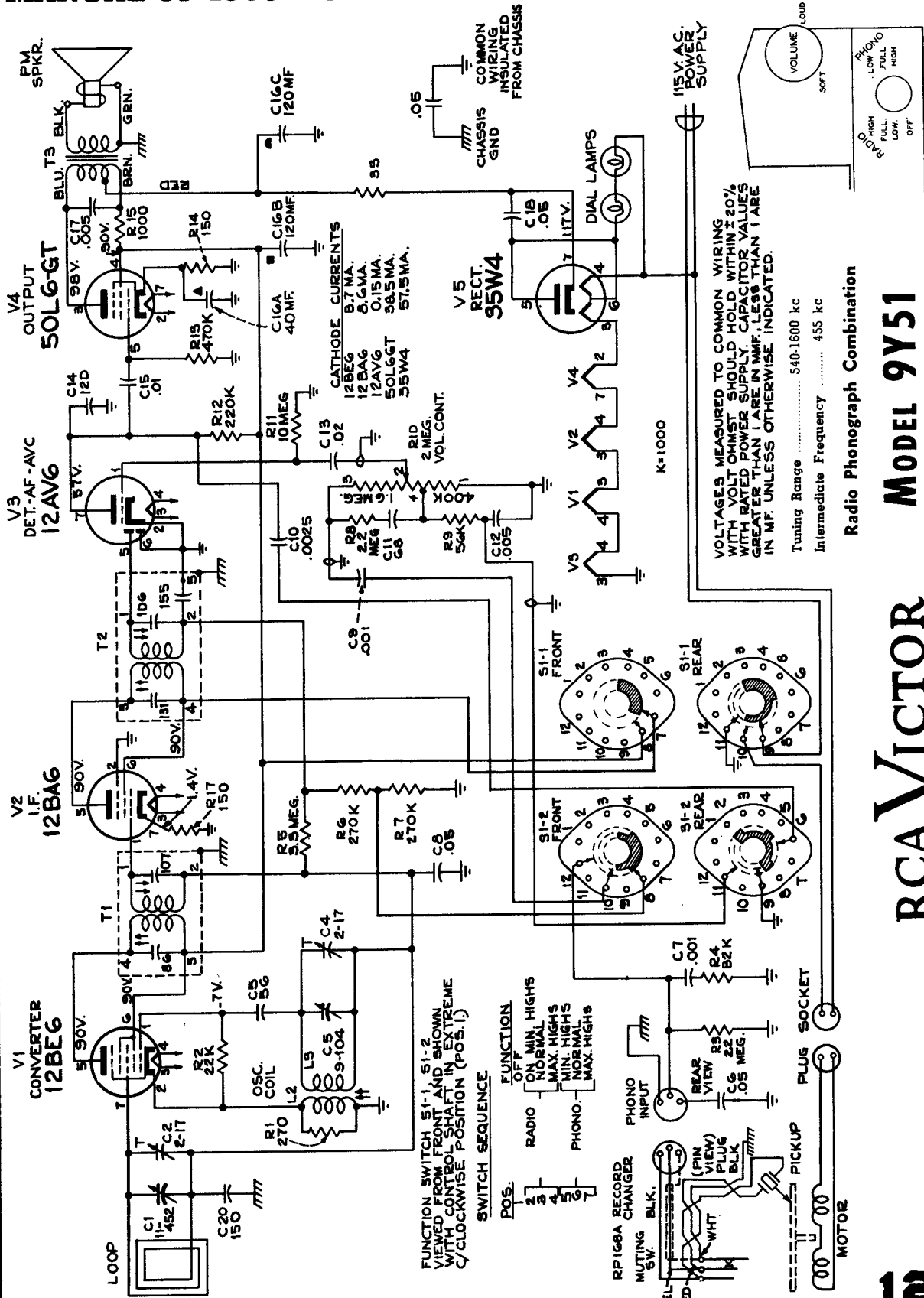

Radio Phonograph Combination

MODEL 9Y51

Chassis No. RC-1077

RCA VICTOR



Controls

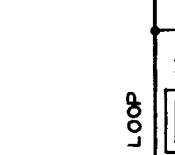
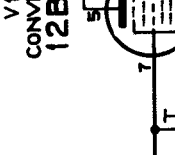
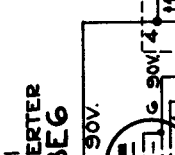
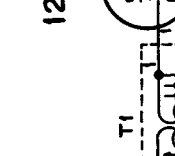
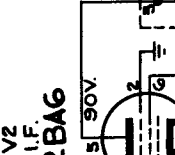
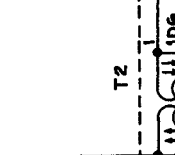
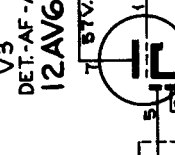
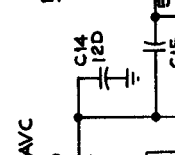
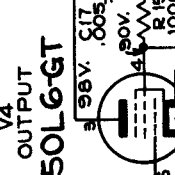
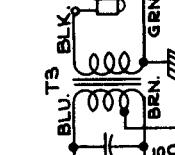
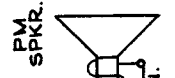
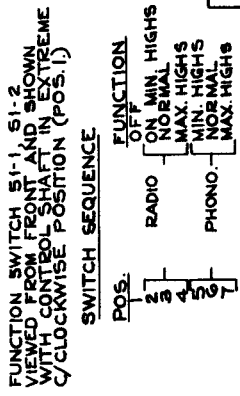
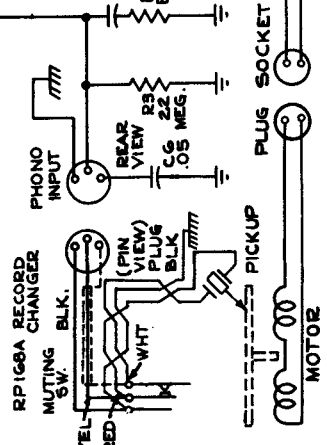
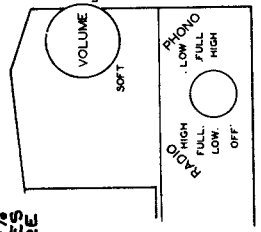

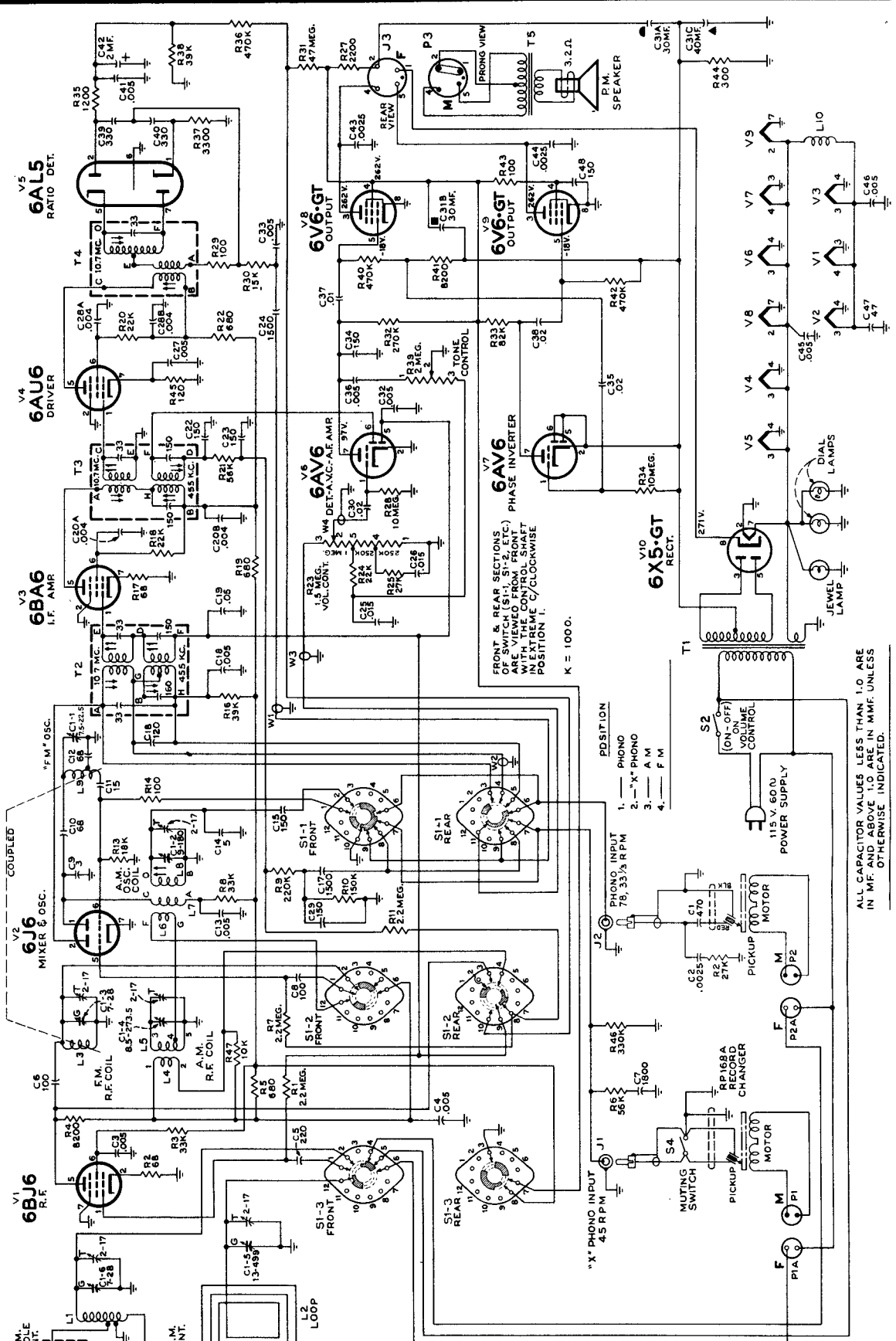

FRONT & REAR SECTIONS (S1-3) ARE VIEWED FROM FRONT WITH THE CONTROL SHAFT IN EXTREME C/CLOCKWISE POSITION I.

K = 1000.

PHONO INPUT POSITION
 1. — PHONO
 2. — "X" PHONO
 3. — A M
 4. — F M

ALL CAPACITOR VALUES LESS THAN 1.0 ARE IN MF. AND ABOVE 1.0 ARE IN MMF. UNLESS OTHERWISE INDICATED.

Complete Schematic Diagram

RCA Victor Models A106 and 9W106, Chassis No. RC-622, Alignment on next page.

MANUAL OF 1950 MOST-OFTEN-NEEDED RADIO DIAGRAMS

RCA VICTOR

MODEL A106
MODEL 9W106
 Chassis No. RC-622

Complete schematic diagram shown on previous page.

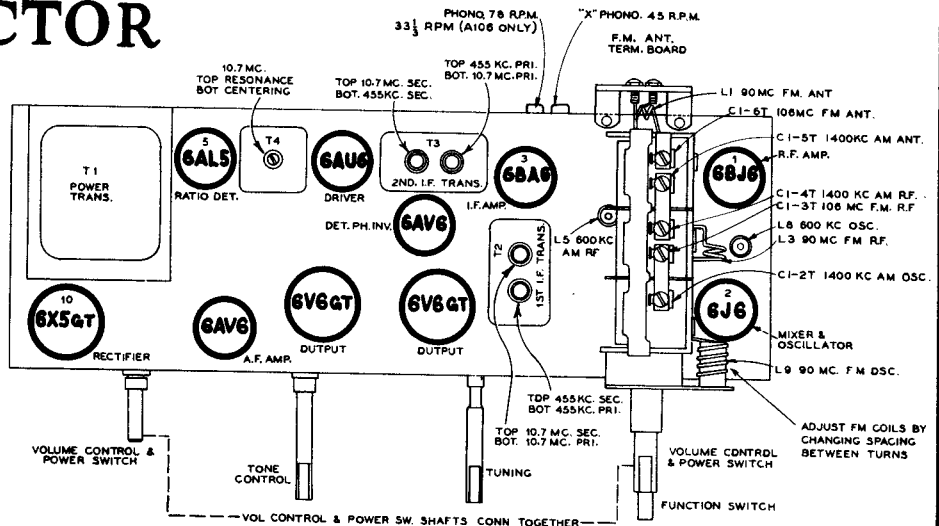

Tube and Trimmer Locations

Alignment Procedure

CORRECT ALIGNMENT OF THE FM BAND REQUIRES THAT THE AM BAND BE ALIGNED FIRST

Alignment Indicators:

An RCA VoltOhmyst or equivalent meter is necessary for measuring developed d-c voltage during FM alignment. Connections are specified in the alignment tabulation. An output meter is also necessary to indicate minimum audio output during FM Ratio Detector alignment. Connect the output meter across the speaker voice coil.

The RCA VoltOhmyst can also be used as an AM alignment indicator, either to measure audio output or to measure a-v-c voltage.

When audio output is being measured the volume control should be turned to maximum.

Signal Generator:

For all alignment operations connect the low side of the signal generator to the receiver chassis. The output should be adjusted to provide accurate resonance indication at all times. If output measurement is used for AM alignment the output of the signal generator should be kept as low as possible to avoid a-v-c action.

AM Alignment

RANGE SWITCH IN BC POSITION

Steps	Connect high side of sig. gen. to—	Sig. gen. output	Turn radio dial to—	Adjust for peak output
1	Pin No. 5 of V2 in series with .01 mid.	455 kc.	Quiet point at low freq. end.	AM windings.† T3 bottom core (sec.). T3 top core (pri.).
2				AM windings.† T2 top core (sec.). T2 bottom core (pri.).
3	Short wire placed near loop for radiated signal	1400 kc.	1400 kc.	C1-2T (osc.). C1-5T (ant.). C1-4T (rl.).
4				L8 (osc.) with 10,000 ohms resistor from RF stator to gnd. (rocking gang)
5				L5 (RF) with the 10,000 ohms removed.
6	Repeat steps 3, 4 and 5 until no improvement in sensitivity is obtained.			

† Use alternate loading.

Alternate loading involves the use of a 47,000 ohm resistor to load the AM plate winding while the AM grid winding of the SAME TRANSFORMER is being peaked. Then the grid winding is loaded with the resistor while the plate winding is peaked. Only one winding is loaded at any one time. Remove the 47,000 ohm resistor after T3 and T2 have been aligned.

Oscillator frequency is above signal frequency on both AM and FM.

FM Alignment

RANGE SWITCH IN FM POSITION—VOLUME CONTROL MAXIMUM

Steps	Connect high side of sig. gen. to—	Sig. gen. output	Turn radio dial to—	Adjust for peak output
1	Connect the d-c probe of a VoltOhmyst to the negative lead of the 2 mid. capacitor C42 and the common lead to chassis. Turn gang condenser to max. capacity (fully meshed). Volume Control max.			
2	Pin 1 of V4 6AUG in series with 470 ohm resistor.	10.7 mc. modulated 30% 400 cycles AM (Approx. .05 volt).	Max. capacity (fully meshed).	T4 top core for max. d-c voltage across C42. T4 bottom core for min. audio output.*
3		10.7 mc. Adjust to provide about 4 volts indication on VoltOhmyst during alignment.		FM windings.†† T3 top core (sec.). T3 bottom core (pri.).
4				FM windings.†† T2 top core (sec.). T2 bottom core (pri.).
5		High and low side of signal gen. through two 120 ohm resistors. To ant. terminals.		90 mc.
8		106 mc.	106 mc.	C1-5T (ant.). C1-3T (rl.).
7		90 mc.	80 mc.	L1 (ant.).** L3 (rl.).**
8	Repeat steps 6 and 7 until no improvement in sensitivity is obtained.			

* Two or more points may be found which lower the audio output. At the correct point the minimum audio output is approached rapidly and is much lower than at any incorrect point.

†† Align T3 and T2 by means of alternate loading as explained under AM alignment. Use a 680 ohm resistor instead of a 47,000 ohm resistor and load the FM windings.

** L1, L3 and L9 are adjustable by increasing or decreasing the spacing between turns.

‡ After dial pointer has been set accurately on calibration point for "A" band (see dial indicator and drive drawing) tune receiver to 90 mc. on FM using dial scale as reference

MANUAL OF 1950 MOST-OFTEN-NEEDED RADIO DIAGRAMS

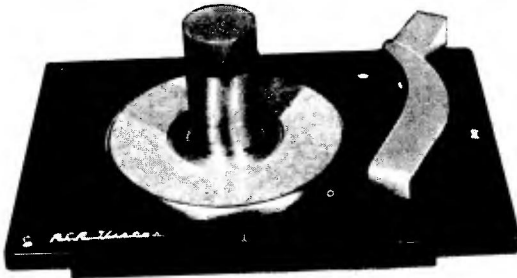

RCA VICTOR

RP-168 Series

45 R.P.M. Automatic Record Changer

Presented on pages 133 to 144.

TYPE AND MODEL IDENTIFICATION

The record changer mechanism may be used either with or without a metal motorboard. When a metal motorboard is not used, the instrument cabinet serves as the motorboard.

Two major changes have been made since the start of production. One change is the type of pickup arm rest, the original design used a visible rest on the motorboard or instrument cabinet which has been replaced by a rest on the sub-base. The other major change is in the record separators, the original type used rotating gear type of separators which were replaced by a push-out type of separators.

Many other changes have been made and there are differences in the color and finish of some parts when used with certain instruments. These changes did not necessarily involve a change in the identification applied to the bottom of the mechanism sub-base.

Five different pickups are in use: Two (2) crystal pickups, one (1) magnetic pickup and two (2) ceramic pickups.

The RP 168 Series record changer is used in the following instrument models:

RECORD PLAYER ATTACHMENTS

9JY, CP-5203, 45J, QJY

RECORD PLAYERS (without radio)

9EY3, 9EY31, 9EY32, 9EY35, 9EY36, 45EY, QEY3

RADIO-PHONOGRAPH COMBINATIONS

9QV5, 9WS1, 9W78, 9W101, 9W102, 9W103, 9W105, 9W106, 9Y7, 9Y51, A55, A78, A106

RADIO-PHONOGRAPH-TELEVISION COMBINATIONS

9TW309, 9TW333, 9TW390, TA128, TA129, TA169, S1000

CAUTION

1. Avoid handling the pickup arm when the mechanism is in cycle.
2. Do not use force to release a jam.
3. Do not try to remove the records on the turntable if the turntable is stopped in cycle.
4. Do not try to operate the mechanism if the separator knives protrude from the center post when the mechanism is out of cycle.

During service, the position of the star wheel on the underside of the record changer may be accidentally shifted; this may cause the separator knives to be extended when they should be concealed.

If the separator knives are thus extended—turn the power on so that the turntable is revolving, push the "start-reject" knob and allow the mechanism to complete a change cycle.

LUBRICATION

A light machine oil (SAE No. 10) should be used to oil the bearings of the drive motor.

On all bearing surfaces, excepting the motor bearings, Houghton STA-PUT No. 320, or equivalent, should be used. On all other sliding surfaces, STA-PUT No. 512, or equivalent, is recommended.

REPLACEMENT PARTS

STOCK No.	ILL. No.	DESCRIPTION
SUB-BASE ASSEMBLIES		
74256	16	Washer—Vellutex washer (pivot arm shaft bearing washer)
74080	17-19	Washer—Washer for turntable bearing
72349	18	Bearing—Turntable thrust bearing
72688	20	Washer—"C" washer—turntable assembly retainer
74079	22	Stud—Idler wheel mounting stud—for Sub-base Types I, II, III, IV, early VI, and early VII
74078	23	Washer—Dampening washer for idler wheel—top
74077	24	Wheel—Idler wheel for all except Model CP-5203
74470	24	Wheel—Idler wheel for Model CP-5203
74132	25	Hardware—Motor mounting hardware consisting of:
	25	Three hex nuts
	26	Three lockwashers
	27-72	Six flat washers
	28	Three spacers
74087	29	Grommet—Rubber grommet to mount motor (3 required)
74089	30	Spring—Idler wheel tension spring (.195" O.D. x .593" —14 turns)
35969	34	Washer—"C" washer to retain pickup arm lift lever
74073	35	Lever—Pickup arm lift lever for mechanisms without dashpot
74757	35	Lever—Pickup arm lift lever for mechanisms with dashpot
	35	Lever—Two piece pickup arm lift lever (use No. 74073 or No. 74757 for replacement)
74805	-	Spring—Tension spring for two piece pickup arm lift lever (.170" O.D. x 3/4")
33726	36	Washer—"C" washer to retain trip pawl
74072	37	Pawl—Trip pawl
74453	-	Washer—Bearing washer between trip pawl (Ill. No. 37) and trip pawl lever (Ill. No. 66)
35969	38	Washer—"C" Washer to retain main lever
74076	41	Lever—Main lever (director lever) for use with turntables having rotating gear record separators
74857	41	Lever—Main lever (director lever) for use with turntables having push-out record separators
74084	42	Spring—Main lever spring (.195" O.D. x .800"—27 1/4 turns)
	43	Screw—Screw to mount muting switch (No. 6-32 or No. 6 self tapping)
	44	Washer—No. 6 lockwasher used with Item 43 (No. 6-32 screw)
74070	45	Base—Sub-base assembly complete with all staked and riveted parts, including idler lever and reject lever—Type I without pickup rest
74743	45	Base—Sub-base assembly complete with all staked and riveted parts, including idler lever and reject lever—Type III with pickup rest
74468	45	Base—Sub-base assembly complete with all staked and riveted parts, including idler lever and reject lever—less No. 74473 bracket—Type IV—for RP-168-2—used only on Model CP-5203
74473	-	Bracket—Metal bracket with power input connector and audio output jack—RP168-2 only
74856	45	Base—Sub-base assembly complete with all staked and riveted parts—less idler lever and reject lever—Type V—with pickup rest
74803	45	Base—Sub-base assembly complete with all staked and riveted parts, including idler lever—less reject lever—Type VI—with pickup rest
74860	45A-1	Lever—Reject lever—bottom section—for sub-base Types V, VI, and VII
74861	45A-2	Lever—Reject lever—top section—for sub-base Types V, VI, and VII
74814	45B	Plate—Idler wheel mounting plate and stud—for sub-base Type V
74870	45B-1	Retainer—Idler wheel retainer (spring sleeve) for use with No. 74814 plate (45B)
75081	45B-1	Retainer—Idler wheel retainer (horseshoe washer) for use with sub-base Types VI and VII (late production)
74804	45B-2	Washer—Idler wheel bearing washer (1/2" O.D. x .185" I.D. x .032" thick) for sub-base Types VI and VII (late production)
74430	45C	Stud—Eccentric stud for landing adjustment
74429	45D	Stud—Eccentric stud for height adjustment
74082	45E	Washer—Felt washer (1/2" O.D. x 1/4" I.D. x 3/16" thick)
74086	46	Spring—Reject lever spring (.203" O.D. x 13/16"—34 3/4 turns) for sub-base having one piece reject lever—1 required

Parts list continued on page 134.

133

MANUAL OF 1950 MOST-OFTEN-NEEDED RADIO DIAGRAMS

RP-168 Series

REPLACEMENT PARTS—Continued

STOCK No.	ILL. No.	DESCRIPTION
74427	46	Spring—Reject lever spring (.203" O.D. x .531"—13 turns) for sub-bases having two piece reject lever—2 required
74074	50	Lever—Return lever (includes spring Ill. No. 51)
74085	51	Spring—Return lever actuating spring (.195" O.D. x 29/32"—37½ turns)
74075	52	Spring—Return lever latch spring (.180" O.D. x .535"—21½ turns)
—	54	Washer
—	55	Nut
—	56	Washer
—	57	Screw
74099	58	Lever—Trip lever (includes Items 54, 55, 56, 57 and 59)
74426	59	Spring—Trip lever spring (.171" O.D. x .595"—30 turns)
33726	60	Washer—"C" washer for star wheel shaft
74083	61	Screw—No. 6-32 x .281" cone point set screw for star wheel (2 required)
74081	62	Wheel—Star wheel
74088	63	Switch—Muting switch
—	64	Screw—No. 8 x ¼" self tapping screw
33726	65	Washer—"C" washer to retain trip pawl lever
74245	66	Lever—Trip pawl lever
74100	67	Spring—Trip pawl take up spring (.195" O.D. x 5/8"—20½ turns)
—	68	Clamp—Cable clamp
74078	69	Washer—Dampening washer for idler wheel (bottom)
—	70	Washer—No. 4 lockwasher for idler mounting stud (Ill. No. 22)
—	71	Nut—No. 4-40 hex nut for idler wheel mounting stud (Ill. No. 22)
—	72	Washer—Part of No. 74132—see Ill. No. 27
74071	73	Motor—115 volt, 60 cycle motor complete with connector—shaded pole type. Not suitable for 50 cycle conversion
74624	73	Motor—115 volt, 60 cycle motor complete with connector and No. 73158 spring sleeve (for 50 cycle conversion), shaded pole type
74469	73	Motor—115 volt, 60 cycle motor complete with connector and 5 mf. capacitor—for RP 168-2 only
74621	—	Capacitor—Motor capacitor (5 mf.) for No. 74469 motor
30870	74	Connector—Two prong male plug (connector) for motor cable
73158	—	Spring—Spring sleeve to convert motors No. 74624 to 50 cycle operation
—	89	Screw—No. 8 x ¼" self tapping screw
74859	90	Clamp—To mount dash-pot
74428	91	Dash-pot—Pneumatic dash-pot complete with plunger
74431	92	Washer—"C" washer for mounting adjustment studs No. 74429 (Ill. No. 45D) and No. 74430 (Ill. No. 45C)
PICKUP ARM ASSEMBLIES		
74041	9	Arm—Pickup shell and stud—with pivot (9B) and lead counter-balance—Type I for use with rest on motor-board
74443	9	Arm—Pickup arm shell and stud—with pivot (9B) and lead counter-balance—for Model CP-5203 only—black finish
74824	9	Arm—Pickup arm shell and stud—with pivot (9B) and lead counter-balance—Type II for use with rest on sub-base
75058	9	Arm—Pickup arm shell and stud—with pivot (9B) and lead counter-balance—for Model 45EY only—two-tone finish
75073	9	Arm—Pickup arm shell and stud—with pivot (9B)—less lead counter-balance—Type III—for use with either type of pickup rest
74796	9	Arm—Pickup shell and stud—with pivot (9B)—less balance spring—Type V—for use with either type of pickup rest
74061	9B	Pivot—Pickup arm pivot—for use with arms No. 74041, No. 74443, No. 74824, and No. 75058 only (arms stamped 970488)
74067	10	Pickup—Crystal pickup cartridge complete including sapphire and guard—RMP 128-1
74625	10	Pickup—Crystal pickup cartridge complete including sapphire and guard—RMP 128-2
74466	10	Pickup—Magnetic pickup cartridge complete with stylus—for Model CP-5203 only
74984	10	Pickup—Ceramic pickup cartridge complete with stylus—for Models QJY and QEY3
*S-5578	10	Pickup—Ceramic pickup cartridge complete with stylus—for Model 9QV5
74065	10A	Screw—No. 2-56 x 3/16" fillister head screw to mount No. 74067 or No. 74625 crystal pickups or No. S-5578 ceramic pickup
74464	10A	Screw—No. 2-56 x 1/4" fillister head screw to mount No. 74466 pickup (Model CP-5203)
74986	10A	Screw—No. 2-56 x 3/16" screw for mounting No. 74984 pickup (Models QJY and QEY3)
74069	10B	Guard—Stylus guard for No. 74067 pickup (RMP 128-1)
74819	10B	Guard—Stylus guard for No. 74625 pickup (RMP 128-2)
74068	10C	Sapphire—Sapphire and holder (WHITE) for No. 74067 pickup (RMP 128-1)
74818	10C	Sapphire—Sapphire and holder (BLUE) for No. 74625 pickup (RMP 128-2)
74622	10C	Stylus—Diamond stylus and holder for No. 74466 pickup (Model CP-5203)
74985	10C	Stylus—Stylus and holder for No. 74984 pickup (Models QJY and QEY3)
74230	10D	Washer and Nut—to mount No. 74068 or No. 74818 stylus
74065	11	Screw—No. 2-56 x 3/16" fillister head screw to mount stylus guard on No. 74067 or No. 74625 pickups
74062	12	Screw—No. 8-32 x 13/32" cone point pivot adjusting screw

STOCK No.	ILL. No.	DESCRIPTION
72765	13	Nut—Speed nut to hold pickup arm cable
74801	—	Clip—Spring clip to hold pickup arm cable (used only on pickup arm Type V and VI—No. 74796)
74410	14	Screw—No. 4-40 x 3/16" fillister head screw to lock pivot screw No. 74062
74066	15	Cable—3-wire twisted pickup arm cable complete with connectors
74465	15	Cable—Shielded pickup arm cable complete with connectors—Model CP-5203 only
*S-5580	15	Cable—Shielded pickup arm cable complete with connectors—Model 9QV5 only
74060	39	Spring—Counter-balance spring (.171" O.D. x .695"—43 turns) for Pickup Arm Types I, II, III and IV when using No. 74067, No. 74625 or No. 74984 pickups (most models)
74426	39	Spring—Counter-balance spring (.171" O.D. x .595"—30 turns) for Model 9QV5 only
74461	39	Spring—Counter-balance spring (.185" O.D. x .695"—29¾ turns) for Model CP-5203 only
74798	39	Spring—Counter-balance spring (3/8" O.D.—11 turns) for Pickup Arm Types V and VI (Stock No. 74796)
74797	—	Nut—Speed nut to hold No. 74798 spring in Pickup Arm Types V and VI
75074	—	Weight—Lead counter-balance weight for Pickup Arm Types III and IV
—	—	Screw—No. 4-40 round head screw to hold No. 75074 weight to No. 75073 Arm
74059	40	Arm—Pivot arm and shaft for use with all pickup arms having lead counter-balance except Model CP-5203
74744	40	Arm—Pivot arm and shaft for Model CP-5203 only
74799	40	Arm—Pivot arm and shaft for use with Pickup Arm Types V and VI
74802	—	Screw—No. 4 x 9/16" oval head counter-balance adjusting screw for use with No. 74799 pivot arm
74800	—	Bumper—Rubber bumper for No. 74799 pivot arm
TURNTABLE ASSEMBLIES		
74090	1	Nose—Spindle nose—RED (early type—thin wall) for Turntable Type I
74620	1	Nose—Spindle nose—RED (late type—thick wall) for Turntable Type I or II
74863	1	Nose—Spindle nose—RED—for Turntable Type III
74472	1	Nose—Spindle nose—BLACK—for Turntable Type I
74795	1	Nose—Spindle nose—BLACK—for Turntable Type III
74091	2	Spring—Spindle nose spring—formed—for spindle nose No. 74090, No. 74620, or No. 74472
74862	2	Spring—Spindle nose spring—formed wire—for spindle nose No. 74863 or No. 74795
—	3	Screw—No. 6-32 round head machine screw for spindle nose spring No. 74091
74095	4	Spring—Separator shell return spring (.180" O.D. x 1 1/16"—10 turns) for Turntable Types I and II
74866	4	Spring—Separator shell return spring (.118" O.D. x 3/4"—16 turns)—two required—for Turntable Type III
74096	5-6	Separator—Separator knife, shelf and gear assembly for Turntable Types I and II
74865	5-6	Shelf—Separator shelf for Turntable Type III
74864	5B	Separator—Separator knife for Turntable Type III
—	6B	—
74092	7	Shaft—Star wheel shaft and gear assembly for Turntable Types I and II
74867	7	Shaft—Star wheel shaft with cam for Turntable Type III
33726	8	Washer—"C" washer for top of No. 74867 shaft
74042	8	Turntable—Turntable with TAN MARBLEIZED mat—Type I—use No. 74090 RED nose thin wall.
75065	8	Turntable—Turntable with TAN MARBLEIZED mat—Type I—use No. 74620 RED nose thick wall
74813	8	Turntable—Turntable with TAN MARBLEIZED mat—Type III—use No. 74863 RED nose
74445	8	Turntable—Turntable with BLACK mat—Type I—use No. 74472 BLACK nose
75145	8	Turntable—Turntable with RED mat—Type I—use No. 74472 BLACK nose
75059	8	Turntable—Turntable with RED mat—Type III—use No. 74795 BLACK nose
74094	8C	Mat—Turntable mat—TAN MARBLEIZED
74471	8C	Mat—Turntable mat—BLACK
74794	8C	Mat—Turntable mat—RED
—	21	Screw—No. 6-32 x 13/32" fillister head screw holds nose to spindle) two required for Turntable Type I
74868	21	Screw—No. 6-32 x 15/32" fillister head screw holds nose to spindle) two required for Turntable Types II and III
74869	21A	Washer—No. 6 flat washer for use under No. 74868 screw—two required for Turntable Types II and III
—	31	Screw—No. 4-40 x 3/8" fillister head screw for use with cam. Ill. No. 33)—two required for Turntable Type I
—	32	Washer—No. 4 lockwasher—for use with cam Ill. No. 33)—two required for Turntable Type I
74231	33	Cam—Follower cam for Turntable Type I

Two different main levers (director lever) are used, depending upon which turntable assembly is used. Lever (41) Stock No. 74076 has a long end (41C) and is used with Turntables Type I and II. Lever (41) Stock No. 74857 has a short end and is used with Turntable Assembly Type III.

Items listed but without Stock Nos. are not stock items.

Parts list continued on page 138.

MANUAL OF 1950 MOST-OFTEN-NEEDED RADIO DIAGRAMS

RP-168 Series

CYCLE OF OPERATION

Function	Explanation
Place records over the center post and turn the power on	1. Records rest on separator shelves protruding from either side of the center post.
Push start-reject knob	1. Start-reject knob which is linked to start-reject slide (45A) moves trip pawl (37) into tripping position. 2. As the turntable rotates, the small projection (8A) (extending from the underside of the turntable) contacts end of trip pawl.
Pickup arm rises	1. As the turntable continues to rotate it carries the trip pawl (37) along for a short distance. 2. The stud (37A) on trip pawl applies force against director lever (41) in opposition to tension spring (42). This force continues to be applied until the stud (41B) on the director lever has been forced through the slot and into the cycling cam (8B). 3. The end (41C) of the director lever extending below the motorboard moves away, allowing the muting switch (63) to close. 4. At the same time the stud (41A) pushes the pickup arm lift lever (35) which in turn raises the pickup arm.

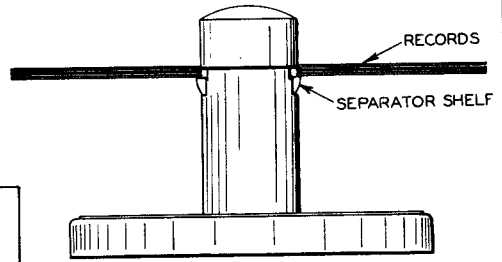

Figure 1.

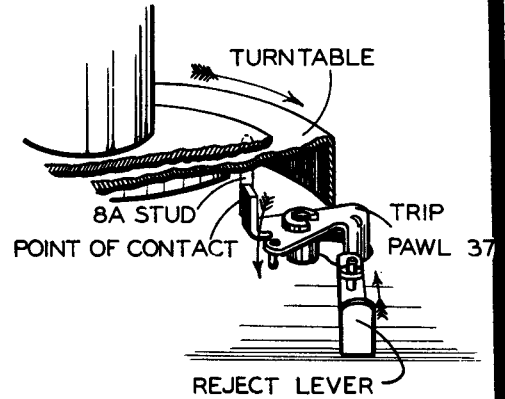

Figure 2.

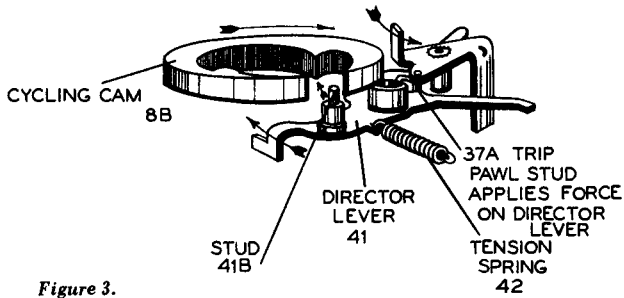

Figure 3.

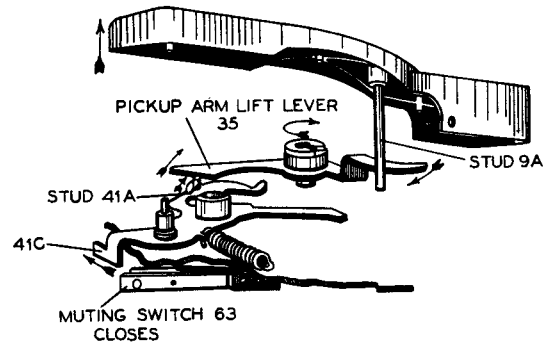

Figure 4.

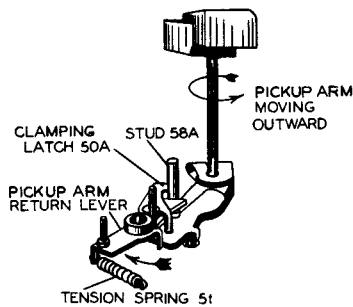

Figure 5.

Pickup arm moves out	1. The end (41E) of the director lever (41) contacts stud (58A) on trip lever (58), starting the pickup arm on its outward movement. 2. The stud (58A) on trip lever contacts pickup arm return lever (50), pushing it outward against the tension spring (51). 3. As the pickup arm reaches its outermost position, it is locked in position by the latch (50A) clamping the stud (58A) on the end of the pickup arm return lever.
----------------------	---

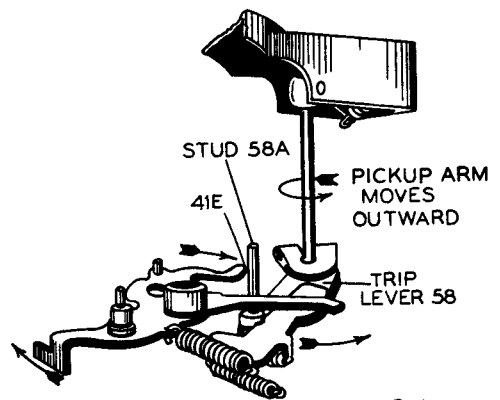

Figure 6.

MANUAL OF 1950 MOST-OFTEN-NEEDED RADIO DIAGRAMS

RP-168 Series

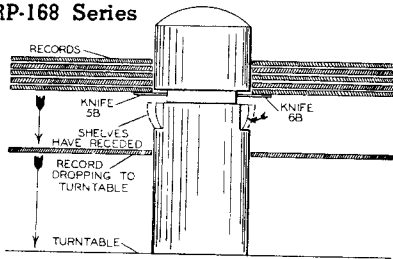
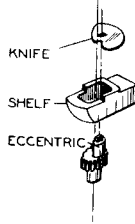

Figure 7.



Separator knives separate the lower record from the stack and allows the record to drop to the turntable

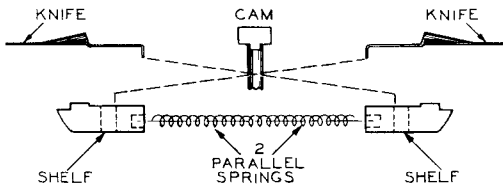

Figure 8.

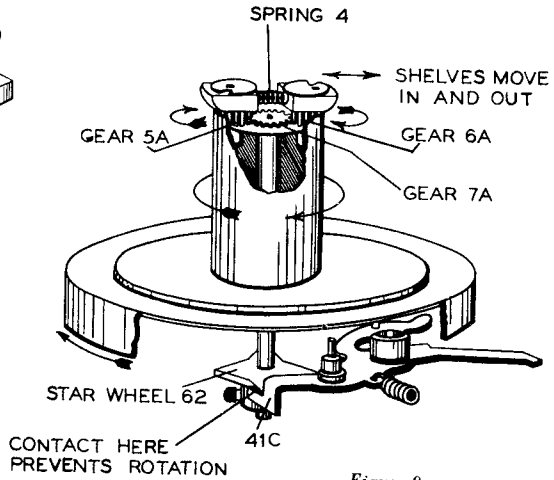

Figure 9.

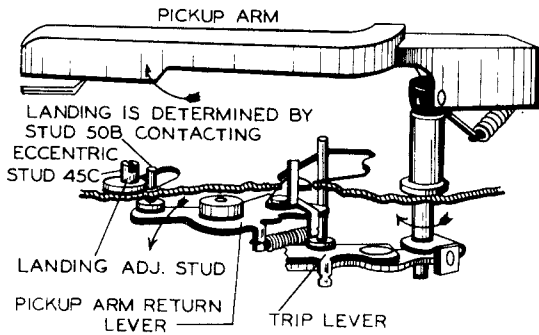

Figure 10.

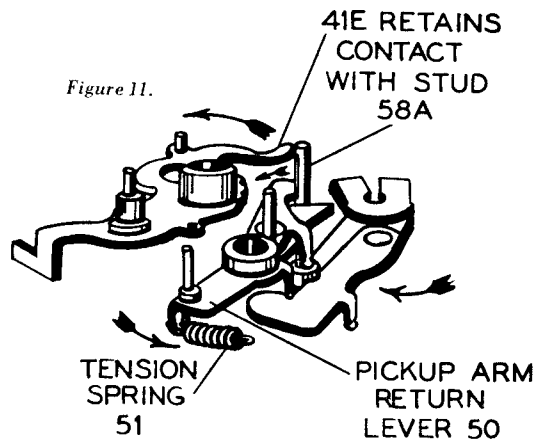

Figure 11.

Pickup arm moves in for landing

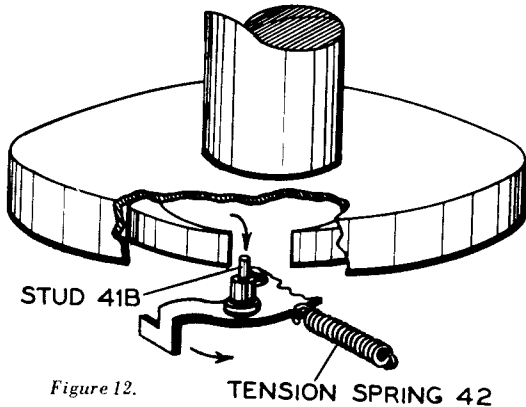

Figure 12.

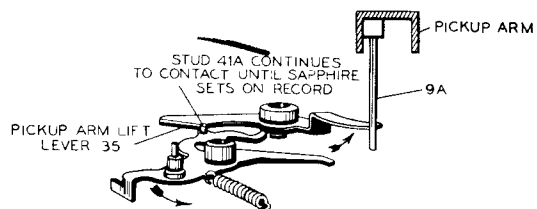

Figure 13.

Sapphire is lowered to the record

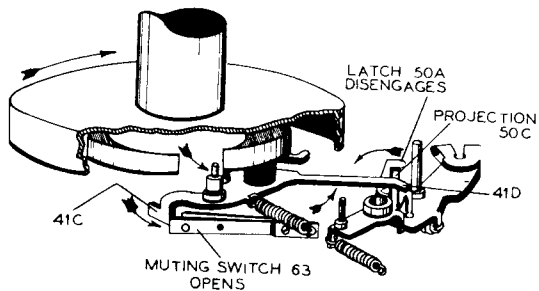

Figure 14.

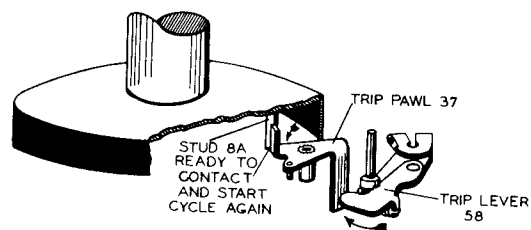

Figure 15.

Playing of record is completed and mechanism starts change cycle

MANUAL OF 1950 MOST-OFTEN-NEEDED RADIO DIAGRAMS

RP-168 Series

Refer to illustrations on page 136.

1. While the pickup arm is moving outward, the end (41C) of the director lever (41) extending below the motorboard, contacts and prevents the star wheel (62) from rotating.
2. Since the turntable continues to rotate and the star wheel and shaft remain stationary, the two small gears (5A and 6A) embedded in the upper section of the center post rotate around the gear (7A) on the upper end of the star wheel shaft (7).
3. The eccentric extending from the upper end of the two embedded gears turns in a slot in the separator shelves (5 and 6). This causes the shelves to move in against the tension of spring (4).

A later type of record separators (knives and shelves), illustrated in Figure 8, are actuated by a cam at the top of the shaft. No gears are used. The cam pushes out on the knives which in turn pull in on the opposite shelves.

4. As the shelves recede the separator knives (5B and 6B), mounted above each separator shelf, separate the lower record of the stack and support the remaining records while the lower record drops to the turntable.

1. As the director lever (41) continues to move toward the out of cycle position the end of the director lever (41E) retains contact with the stud (58A) on the trip lever (58). This contact stabilizes the inward movement of the pickup arm which is being pushed in by the pickup arm return lever (50).
2. The inward movement of the pickup arm is stopped directly above the landing position due to the stud (50B) on pickup arm return lever coming in contact with the eccentric stud (45C).

1. The stud (41A) on director lever (41) continues to contact pickup arm elevating lever (35) and lowers the sapphire on the start of the record.
2. As the turntable completes one revolution, the stud (41B) on director lever is pulled through the slot in the cycling cam by the tension spring (42).
3. The end of the director lever (41D) contacts projection (50C) and unlatches the pickup arm return lever (50).
4. The end (41C) of the director lever below the motor board moves away from the star wheel and opens muting switch.

1. After the selection has been completed the sapphire moves into the tripping groove. At this time the trip lever (58) pushes the trip pawl (37) into position for engagement with the stud (8A) on the underside of the turntable.
2. This contact between stud (8A) and the trip pawl (37) starts another change cycle and the next record is moved into position for playing.

SERVICE HINTS

Care of Pickup

LINT MAY COLLECT TO CLOG THE OPENING IN THE GUARD AT THE STYLUS POINT AND CAUSE POOR RECORD REPRODUCTION. This may require occasional cleaning of the guard opening—clean by carefully brushing with a small soft brush.

Replacement of Stylus

Caution: Never bend the stylus support wire.

CRYSTAL PICKUPS (Stock Nos. 74067 and 74625)

Remove the two screws holding sapphire guard in place and remove the guard. Remove the small nut and washer on the threaded shaft of the sapphire holder and gently push the shaft through the hole in the armature shaft until the sapphire holder assembly comes free.

Extreme care should be used when loosening the nut so that the twisting motion does not break the crystal. Take hold of the lower end of the shaft with a pair of pliers while loosening or tightening the nut, being very careful so as not to strip the threads or break the crystal.

Insert threaded shaft of replacement sapphire holder through armature shaft and replace the washer and nut. Make sure that the sapphire is in the correct position.

Replace the sapphire guard, positioning it by means of the oversize screw slots. Make certain that the sapphire and its supporting wire are centered in the guard. Tighten the guard screws. Before using, check to see that the sapphire projects far enough beyond the guard so that the guard will not touch the record. If necessary, bend the guard a little.

VARIABLE RELUCTANCE PICKUP (Stock No. 74466)

To remove the stylus assembly, insert a bent paper clip or equivalent tool into the stylus stud pin socket at point "A." Press the assembly out from the cartridge with the tool as shown by the arrow in the illustration below.

To replace the stylus assembly, insert the stud pin into the recess "A," with the locating tab positioned above the locating slot "B" between the two pole pieces. Press assembly in firmly by applying pressure upon the stud pin at point "C" with a blunt tool. Care must be taken to press assembly only at point "C" so as not to damage or distort the stylus arm.

CERAMIC PICKUP (Stock No. 74984)

To remove stylus, insert the point of a knife blade between the stylus wire and the case. The stylus may be pried out of its rubber mounting with a twisting motion of the knife blade.

To replace stylus, push end of stylus wire down into its rubber mounting. Be certain that the stylus is centered in the groove of the pickup case.

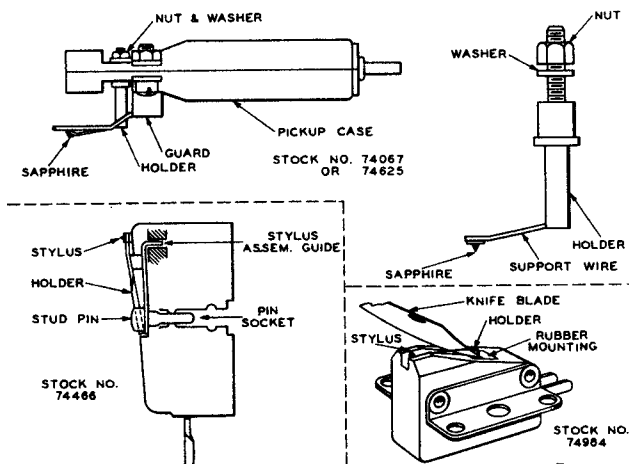
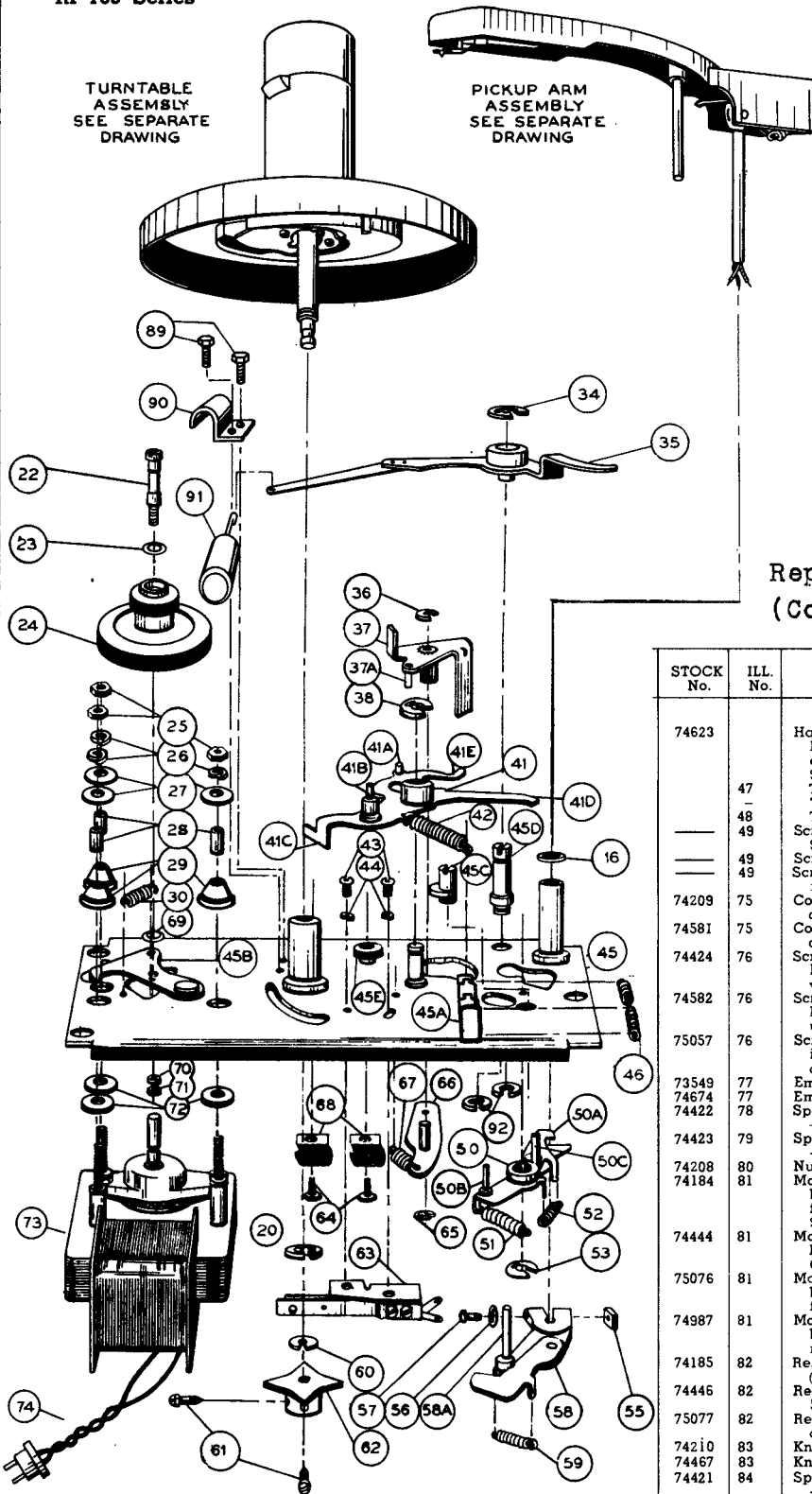

Figure 16—Stylus Replacement.

MANUAL OF 1950 MOST-OFTEN-NEEDED RADIO DIAGRAMS

RP-168 Series



Replacement Parts List (Continued from page 134)

STOCK No.	ILL. No.	DESCRIPTION
MOTORBOARD ASSEMBLIES		
74623		Hardware—To mount sub-base to plastic cabinet of Models 9EY3, 9EY35, 9EY36, 9Y51, 45EY and QEY3 or sub-base to motorboard of Models 9EY31 and 9EY32, consisting of:
	47	Three (3) grommets
	48	Three (3) spacers
	49	Three (3) flat washers
		Screw—No. 8-32 x 3/4" —for Models 9EY3, 9EY35, 9EY36, 9Y51, 45EY and QEY3
	49	Screw—No. 8-32 x 1/2" —for 9Y and 45J
	49	Screw—No. 8-32 x 3/8" —for instruments using spring mounting of motorboard
74209	75	Cover—Mounting screw cover (threaded type—3 required)—use with No. 74424 screw (Ill. No. 76)
74581	75	Cover—Mounting screw cover (plug-in type—3 required)—use with No. 74582 screw (Ill. No. 76)
74424	76	Screw—No. 8-32 x 1 3/4" special screw (with tapped hole) for mounting record changer (3 required)—use with No. 74209 cover (Ill. No. 75)
74582	76	Screw—No. 8-32 x 1 3/4" special screw (non-tapped hole) for mounting record changer (3 required)—use with No. 74581 cover (Ill. No. 75)
75057	76	Screw—No. 8 x 7/8" oval head wood screw for mounting record changer (3 required)—for Models 9EY31 and 9EY32
73549	77	Emblem—"RCA Victor" emblem—metal
74674	77	Emblem—"RCA Victor" emblem—plastic
74422	78	Spring—Conical spring for mounting record changer —upper L.H. side (2 required)
74423	79	Spring—Conical spring for mounting record changer —bottom (3 required)
74208	80	Nut—Tee nut for mounting record changer (3 required)
74184	81	Motorboard — Motorboard complete with welded brackets and stud-less rest and operating parts—for all models with motorboard rest except CP-5203, 9EY31 and 9EY32
74444	81	Motorboard — Motorboard complete with welded brackets and stud-less operating parts—for Model CP-5203
75076	81	Motorboard — Motorboard complete with welded brackets and stud-less rest and operating parts—for Models 9EY31 and 9EY32
74987	81	Motorboard — Motorboard complete with welded brackets and stud-less operating parts—for all models without motorboard rest
74185	82	Rest — Pickup arm rest — maroon — for all models (where required) except CP-5203, 9EY31 and 9EY32
74446	82	Rest — Pickup arm rest — black — used on Model CP-5203 only
75077	82	Rest — Pickup arm rest and latch — for Models 9EY31 and 9EY32
74210	83	Knob — Reject control knob — maroon
74467	83	Knob — Reject control knob — black
74421	84	Spring — Conical spring for mounting record changer — upper R.H. side (1 required)
74212	85	Nut — Speed nut for reject control knob
	86	Screw — No. 6 self-tapping screw
33726	87	Washer — "C" washer for mounting reject lever actuating lever
74211	88	Lever — Reject lever actuating lever
74474	-	Switch — "ON-OFF" switch — used on Model CP-5203 only

Figure 17—Exploded View of Sub-base Assembly.

MANUAL OF 1950 MOST-OFTEN-NEEDED RADIO DIAGRAMS

Figure 18—Pickup Arm Assemblies.

RP-168 Series

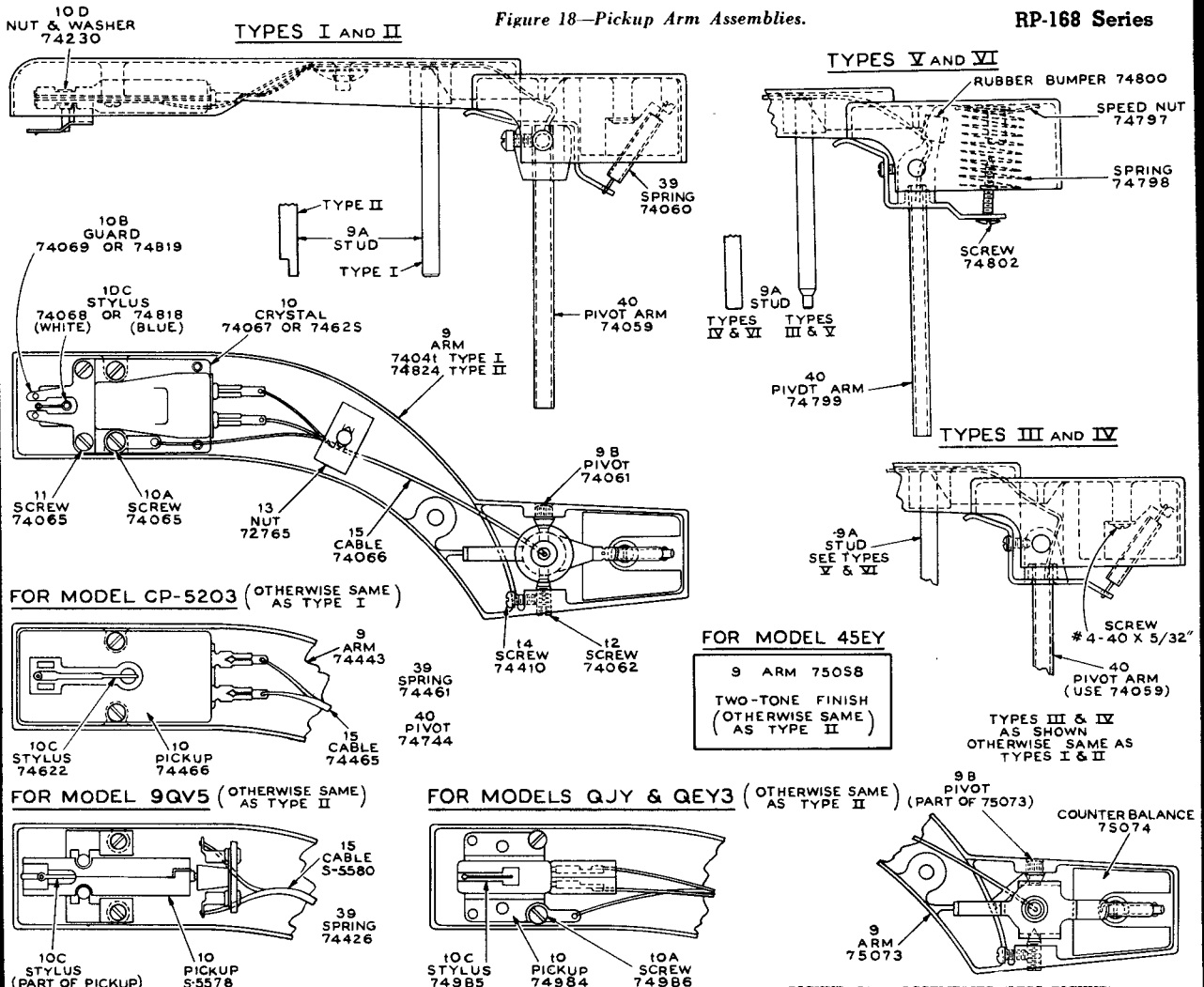

FOR MODEL CP-5203 (OTHERWISE SAME AS TYPE I)

FOR MODEL 45EY

FOR MODEL 9QV5 (OTHERWISE SAME AS TYPE II)

FOR MODELS QJY & QEY3 (OTHERWISE SAME AS TYPE II)

SUB-BASE ASSEMBLIES

- Type I**
Sub-base Stock No. 74070. Has staked studs for spring anchors and one-piece reject lever. Stamped or labelled RP168-1 or RP168-3.
- Type II**
Same as Type I, except it uses a two-piece reject lever. Use Stock No. 74743 Sub-base (Type III) for replacement.
- Type III**
Sub-base Stock No. 74743. Same as Type II, except that it has pickup arm rest on sub-base (when motorboard rest is used, the sub-base rest is to be deformed).
- Type IV**
Sub-base Stock No. 74468. It uses an a.c. input connector and audio output jack mounted on a separate bracket. Labelled RP168-2 and used only with Model CP-5203.
- Type V**
Sub-base Stock No. 74856. Has turned up lances for spring anchors. Idler wheel mounting plate (45B—Stock No. 74814) is removable. It is labelled RP168-1, RP168B-1, etc. It has pickup arm rest on sub-base (when motorboard rest is used, the sub-base rest is to be deformed).
- Type VI**
Stock No. 74803. Similar to Type V, but it does not bear any "RP168" identification. It has pickup arm rest on sub-base. Idler wheel mounting plate (45B) is secured to the sub-base with a shoulder rivet.
- Type VII**
Same as Type VI, except it does not have pickup arm rest on sub-base. Use Stock No. 74803 (Type VI) for replacement (the pickup arm rest is to be deformed).

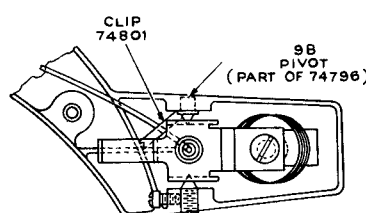

NOTE: Types VI and VII
Late production of these types have the idler wheel mounting stud (22) staked to its mounting plate. The idler wheel retainer (horseshoe washer) is Stock No. 75081.

NOTE: Type V
Two different main levers (director lever) are used, depending upon which turntable assembly is used. Lever (41) Stock No. 74076 has a long end (41C) and is used with Turntables Types I and II. Lever (41), Stock No. 74857 has a short end and is used with Turntable Type III.

- PICKUP ARM ASSEMBLIES (LESS PICKUP)**
- Type I**
Arm Stock No. 74041. Stamped 970488. Pickup arm stud (9A) is full diameter for entire length (do not use where pickup arm rest is on sub-base). Lead counter-balance is riveted to arm.
- Arm Stock No. 74443. For Model CP-5203 only. Black finish, otherwise similar to No. 74041.
- Type II**
Arm Stock No. 74824. Same as No. 74041 except that stud (9A) has a flat on one side at bottom end. Can be used with either type of pickup rest.
- Arm Stock No. 75058. For Model 45EY only. Two-tone finish, otherwise same as No. 74824.
- Type III**
Arm stock No. 75073. Stamped 3R1. Similar to No. 74824 except that a different pivot (9B) is used and the lead counter-balance is fastened to the arm with a screw. Stud (9A) is of smaller diameter at bottom end. Can be used with either type of pickup rest. Use only with No. 74059 pivot arm.
- Type IV**
Same as Type III except that stud (9A) is of full diameter for entire length. Use No. 75073 for replacement.
- Type V**
Arm Stock No. 74796. Stamped 3R1. Similar to Type III except that a different pivot (9B) is used and the lead counter-balance is not used. A 5/8" O.D. counter-balance spring is used. Can be used with either type of pickup rest. Use only with No. 74799 pivot arm.
- Type VI**
Same as Type V except that stud (9A) is of full diameter for entire length. Use No. 74796 for replacement.

MANUAL OF 1950 MOST-OFTEN-NEEDED RADIO DIAGRAMS

RP-168 Series

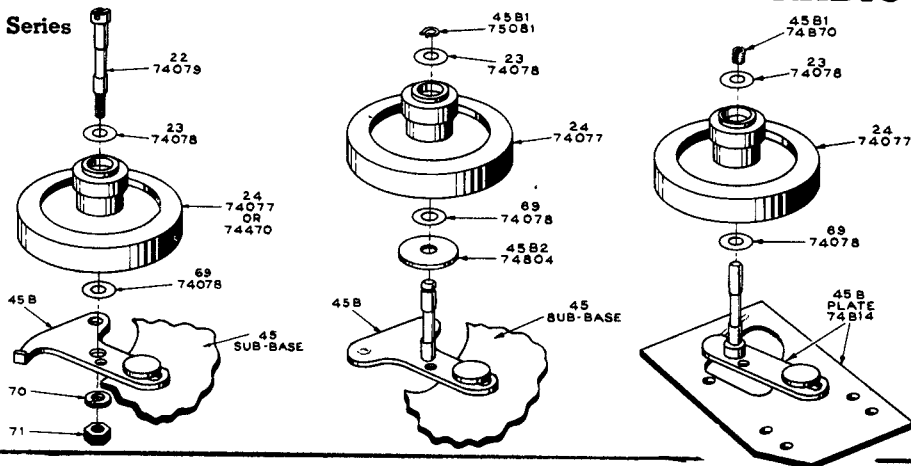
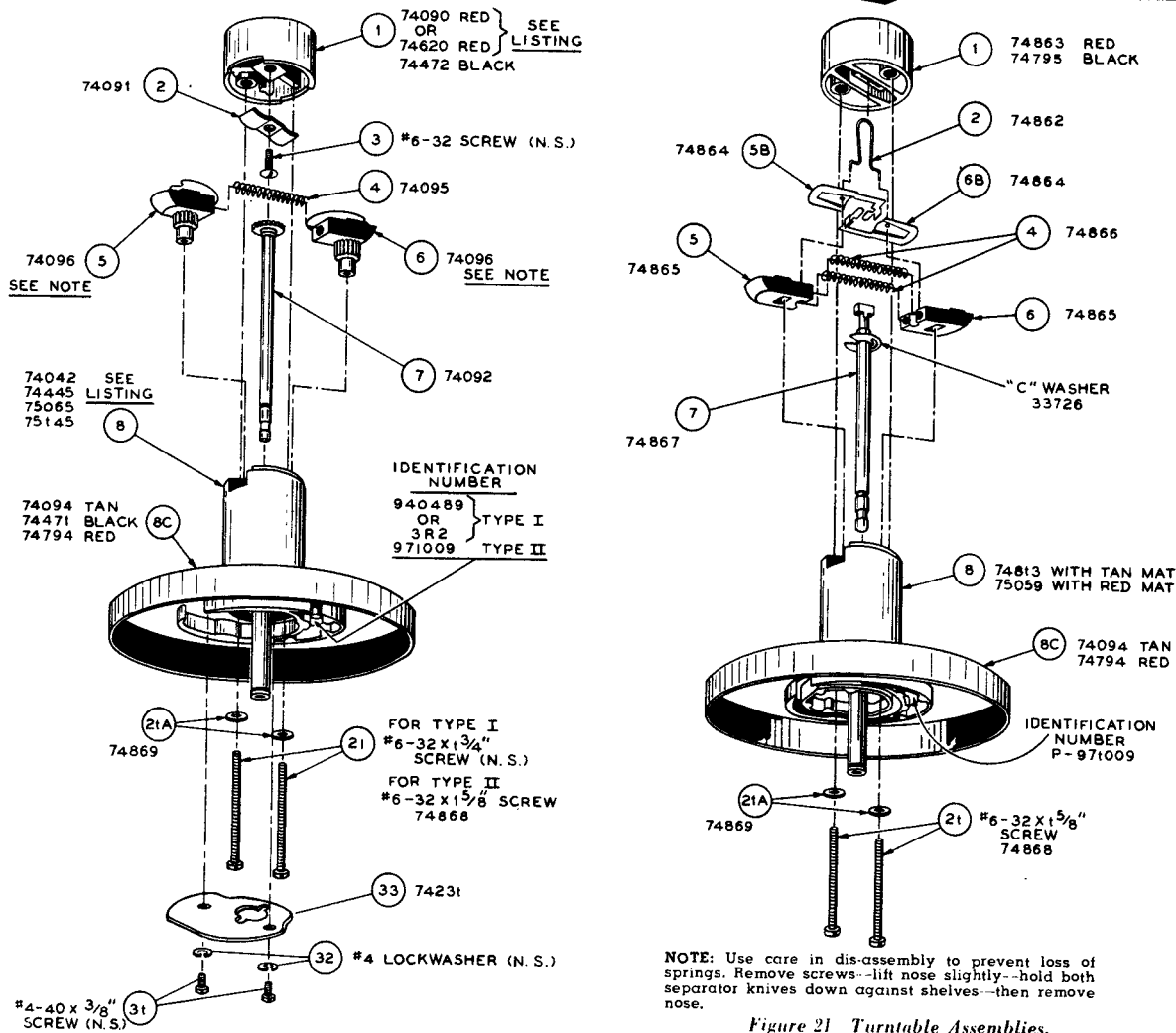

Figure 19—
Idler Wheel
Mounting.



ON TYPE II TURNTABLES THE CAM (33) IS
CAST INTEGRAL WITH THE TURNTABLE (8)

Figure 20. Turntable Assemblies,
Types I and II.

NOTE: Use care in dis-assembly to prevent loss of
springs. Remove screws--lift nose slightly--hold both
separator knives down against shelves--then remove
nose.

Figure 21 Turntable Assemblies,
Type III.

Main Lever vs Record Separators:

Two different main levers (director lever) are used depending upon the type of record separators being used.

Stock No. 74076 lever is used only with the rotating gear type of record separators. The end (41C) that engages the star wheel is long.

Stock No. 74857 lever is used only with the push-out type of record separators. The end (41C) that engages the star wheel is short.

MANUAL OF 1950 MOST-OFTEN-NEEDED RADIO DIAGRAMS

CHANGES—SERVICE HINTS (Continued)

RP-168 Series

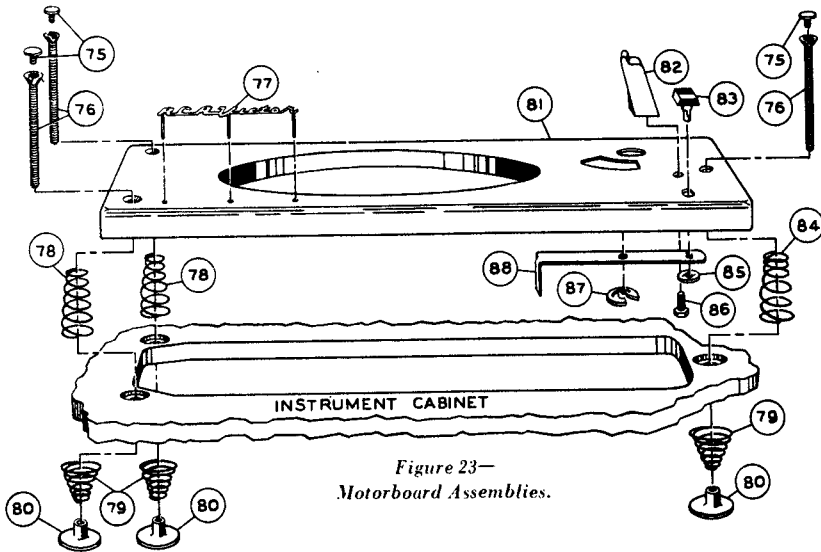

Figure 23—
Motorboard Assemblies.

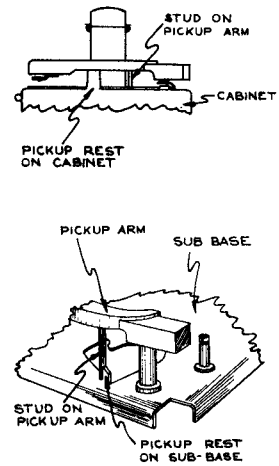

Figure 24—Pickup Arm Rest.

Pickup Arm Rest:

Two different types of pickup arm rest are in use. The original type was visible on the motorboard. The type presently in use is a metal projection on the sub-base.

Sub-base Mounting:

The sub-base is attached directly to metal motorboards and to the cabinets of Models 9JY, QJY and 45J with three screws and three washers. No grommets or spacers are used except with Models 9EY31 and 9EY32.

On all other instruments, the sub-base is cushion mounted to the plastic cabinet with rubber grommets, metal spacers, screws and washers. The mounting is illustrated below.

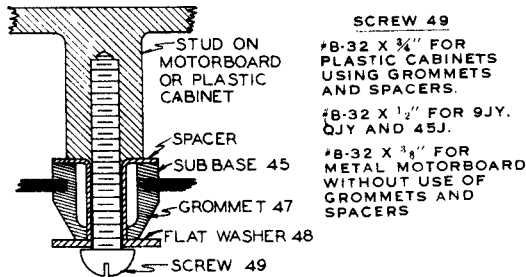

Figure 25—Sub-base Mounting.

Separator Assemblies (Rotating Gear Type):

A flat has been added to the separator gears eccentric shafts. This flat permits the shelf (Ill. Nos. 5 and 6) to stay out until the nose of the blade (Ill. Nos. 5B and 6B) is approximately half-way out. Then the shelf retracts fast. This faster action minimizes unequal dropping of records.

The two types of separator assemblies (Stock No. 74092 Ill. No. 7) are NOT INTERCHANGEABLE. In addition the early type has been grouped according to mold number (at bottom of spring hole) and installed in pairs.

Group	Group	Group
Mold Number	Mold Number	Mold Number
1, 3, 5	9, 10	0, 8

Assemblies of one group should not be mixed with assemblies of another group or unequal dropping of records may occur. If a matched pair is not available, first check timing of separator knives then the dropping of records; it may be necessary to file the edge of the shelf which released the record last.

The late type (having a flat on the eccentric shaft) do not need to be grouped, but an early assembly should not be used in conjunction with a late assembly (use two early or two late assemblies). The late type may be identified by its having a shroud at the top of the gear (see Figure 27).

Spindle Nose and Turntable (Type I):

The wall thickness of the spindle nose (Ill. No. 1) has been increased and the machined shoulder at the top of the turntable decreased accordingly. Thick wall spindle nose will not fit on early type turntable. The new type red spindle nose (thick wall) is available as Stock No. 74620.

NOTE: The screws (Ill. No. 21) which hold the spindle nose to the turntable should not be tightened too tight. The spindle nose can be distorted and cause records to bind.

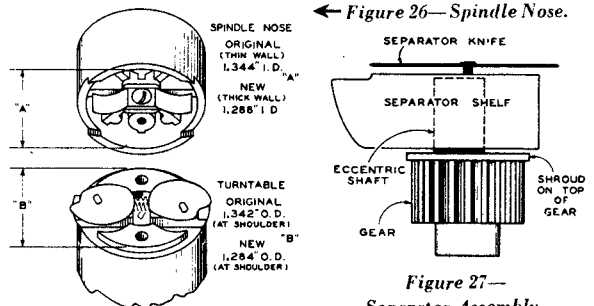

Figure 26—Spindle Nose.

Figure 27—
Separator Assembly.

Jamming:

On early RP-168-1 mechanisms it was sometimes possible to jam the mechanism by maintaining pressure on the reject button during cycle. If such jamming should occur check the following:

1. The tip radius of the reject lever (Ill. No. 45A) should be $\frac{1}{16}$ ".
2. The edges of the trip pawl (Ill. No. 37) should have a slightly rounded edge (.010" radius).

Present production uses a two piece spring loaded reject lever (Ill. No. 45A) which eliminates the possibility of jamming caused by pressure on the reject button.

Jamming can also be caused by incorrect positioning of the director lever (main lever) (Ill. No. 41) in relation to the star wheel (Ill. No. 62). See Figure 35.

MANUAL OF 1950 MOST-OFTEN-NEEDED RADIO DIAGRAMS

RP-168 Series

CHANGES—SERVICE HINTS (Continued)

Intermittent Non-Tripping:

The trip lever spring (Ill. No. 59) has been increased in tension to provide better tripping action. The new spring has 30 turns and is available as Stock No. 74426.

To reduce friction a washer has been added between the trip pawl (Ill. No. 37) and the trip pawl lever (Ill. No. 66). It is available as Stock No. 74453.

Eccentric Adjustment Studs:

In early production the eccentric landing (Ill. No. 45C) and height (Ill. No. 45D) adjustment studs were staked to the sub-base assembly. They are now secured to the sub-base assembly with "C" washers. The landing adjustment stud (Ill. No. 45C) is available as Stock No. 74430. The height adjustment stud (Ill. No. 45D) as Stock No. 74429 and the "C" washer (Ill. No. 92) as Stock No. 74431.

Pneumatic Dashpot

A pneumatic dashpot (Stock No. 74428) has been added to improve pickup arm landing. The dashpot case is clamped to the base sub-assembly and the plunger is attached to the long end of the tone arm lift lever (Ill. No. 35) (Stock No. 74757).

ADJUSTMENTS

Adjustment Sequence:

1. Synchronize separator shelf (Ill. No. 5) and separator knife (Ill. No. 5B) action (necessary only on rotating gear type of record separators).

2. Adjust position of star wheel (Ill. No. 62).
3. Adjust position of director lever (main lever) (Ill. No. 41) in relation to the star wheel by bending if necessary.
4. Adjust tone arm pivot screw (Ill. No. 12) for minimum side play without binding.
5. Adjust sapphire height above motorboard.
6. Adjust tripping position.
7. Adjust landing position.
8. Adjust pickup arm height during cycle.
9. Adjust position of muting switch so that contacts are open during playing and are closed during cycle.

Separator Synchronization:

The following applies only to the rotating gear type of record separators:

1. Make certain the two embedded gears (5 and 6) are meshed with gear (7A) on the upper end of the star wheel shaft so the action of the separator knives is synchronized.

Star Wheel Position:

1. Turn the star wheel so that the separator knives are in the position indicated in Figure 33 for rotating gear type of separators or fully retracted for push-out separators.
2. Loosen the two set screws (61) sufficiently to permit the star wheel to rotate without disturbing the shaft (7).
3. Rotate the star wheel points directly to a cam screw or nose screw (visible through slot) as shown in Figure 34.
4. Tighten the two set screws (61) and rotate the mechanism through a complete cycle to check operation. The separator knives must rotate 360° to the starting position as indicated in Figure 33.

ERRATIC PICKUP LANDING

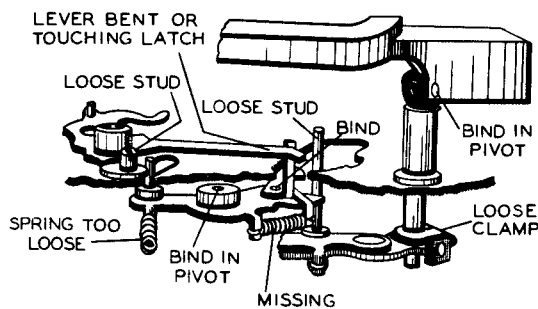

Figure 28.

DISTORTED OUTPUT

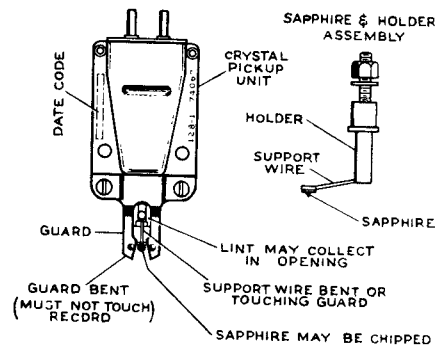

Figure 29.

WOW (Speed Variation)

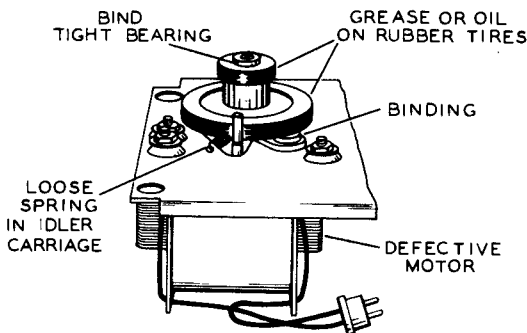

Figure 30.

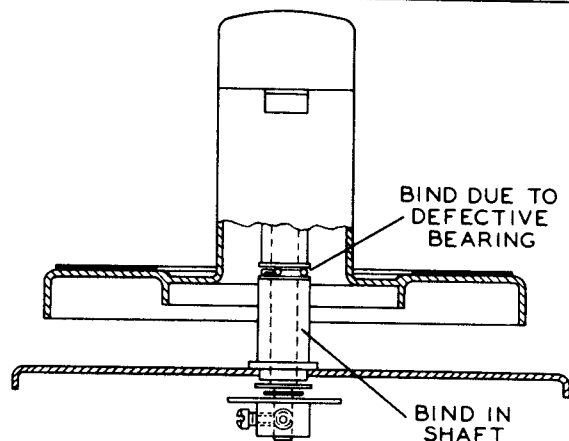

Figure 31.

MANUAL OF 1950 MOST-OFTEN-NEEDED RADIO DIAGRAMS

ADJUSTMENTS (Continued)

RP-168 Series

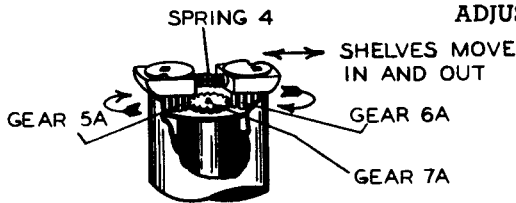

Figure 32.

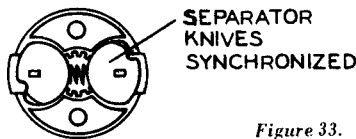

Figure 33.

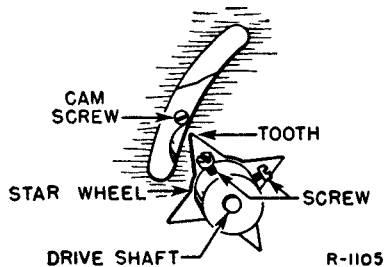

Figure 34—Star Wheel Timing.

Director Lever Position:

Push reject lever and rotate the turntable slowly by hand until the end (41C) of the director lever moves in to its limit of travel so when the star wheel is rotated it contacts by the amount indicated in Figure 35 for lever with long end. For lever with short end, the star wheel should first contact the end (41C) approximately 1/16-inch from the front or leading edge of the lever.

If the end of the director lever (main lever) is too close to the star wheel, it will jam. If too far away, it will cause erratic record dropping. If in doubt and unable to measure, move the end toward the star wheel until most of the play is removed when the star wheel is moved back and forth at this setting. With the push-out record separators and the lever with short end, there will be considerable play but the tension of the separator springs holds the star wheel against the lever.

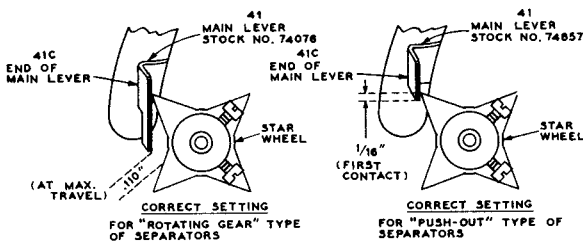

Figure 35 Setting of Director Lever.

Sapphire Height Adjustment (Out of Cycle):

Bend the lug on the pivot arm (40) so that the sapphire point is approximately 1/16" above the motorboard.

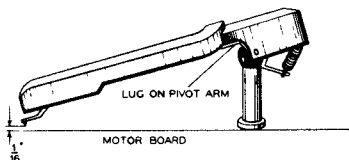

Figure 37.

Pivot Screw Adjustment:

Loosen the pivot locking screw (14) and adjust the pivot screw (12) for minimum side play without causing binding.

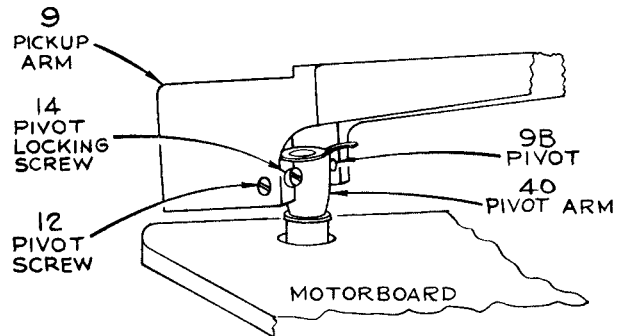

Figure 36.

Tripping Adjustment:

1. Assemble the pickup arm and trip lever assemblies as shown in Figure 38. Leave the clamping screw (57) loose enough to permit horizontal movement of the trip lever on the shaft. (Allow approximately .010 inch vertical end play.)
2. Turn the eccentric landing adjustment stud (45C) to determine the inward and outward limit of adjustment, then turn it to a setting half-way between the limits.

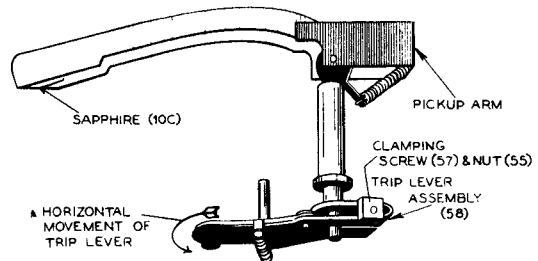

Figure 38.

3. Tripping should occur when the sapphire reaches a position $1\frac{1}{32}$ " from the near side of the turntable spindle. This position is adjusted by holding the trip lever and moving the pickup arm inward or outward to obtain the specified position.
4. A convenient way of measuring this distance is to make a mark on the back side of a stroboscope disc $1\frac{1}{32}$ " from the inner edge, place the disc on the turntable, with the turntable revolving, hold the disc stationary and move the pickup arm very slowly in towards the turntable spindle.
5. After this position has been obtained, tighten the clamping screw (57) and recheck the tripping position and vertical end play.

Landing Adjustment:

1. After the tripping adjustment has been made as described above, turn the eccentric landing adjustment stud (45C) so that the sapphire will set down on the record half-way between the outer edge and the first music groove. This position is $2\frac{5}{8}$ " from the turntable spindle. The location of the adjustment stud is illustrated in Figure 42.

MANUAL OF 1950 MOST-OFTEN-NEEDED RADIO DIAGRAMS

RP-168 Series

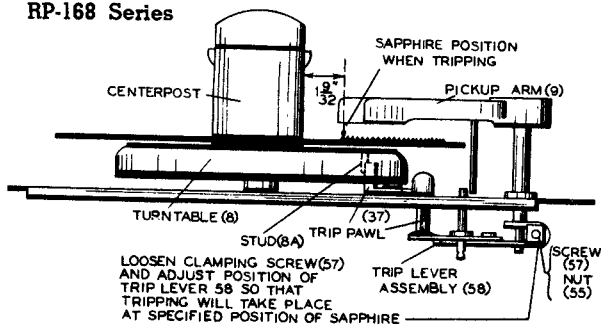

Figure 39—Tripping Position.

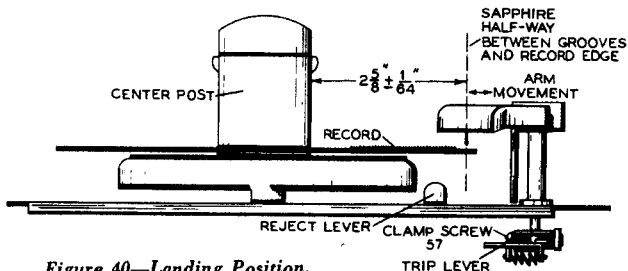

Figure 40—Landing Position.

Pickup Arm Height Adjustment (In Cycle):

Set the mechanism in cycle. Turn the turntable by hand, until the pickup arm has reached its maximum height. By means of a screwdriver turn the height adjustment stud (45D) until the distance between the top of the turntable and the sapphire point is $\frac{3}{4}$ " Use that position of the eccentric stud which causes the pickup arm to rise during clockwise adjustment of the stud. The location of the adjusting stud is illustrated in Figure 42.

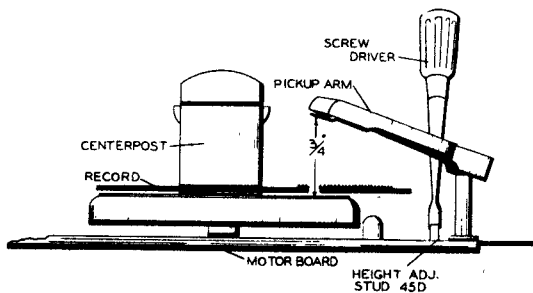

Figure 41—Height Adjustment.

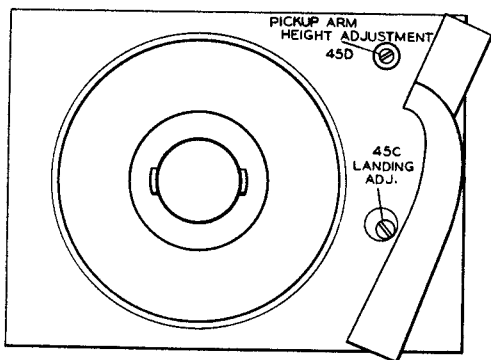

Figure 42—Height and Landing Adjustment Studs.

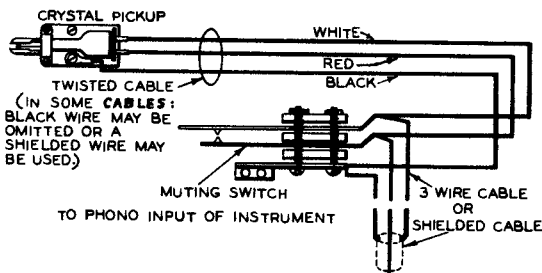

Figure 43—Pickup Muting Switch Wiring.

SERVICE HINTS (Continued)

REPEATS GROOVES

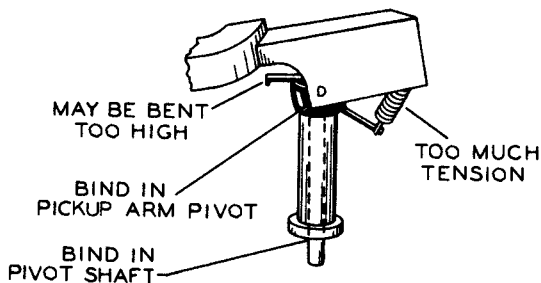

Figure 45.

FAILS TO GO INTO CYCLE

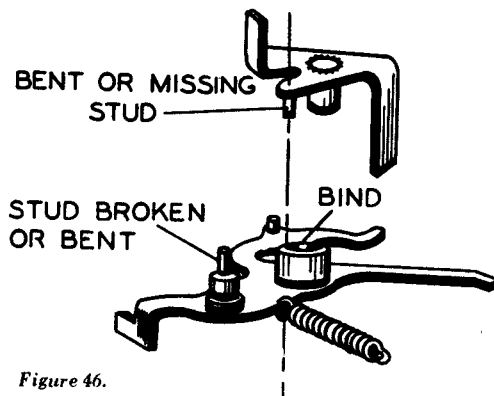

Figure 46.

RECORD DROP ON OR HIT PICKUP ARM

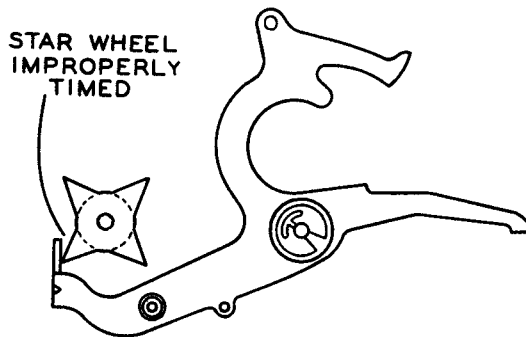
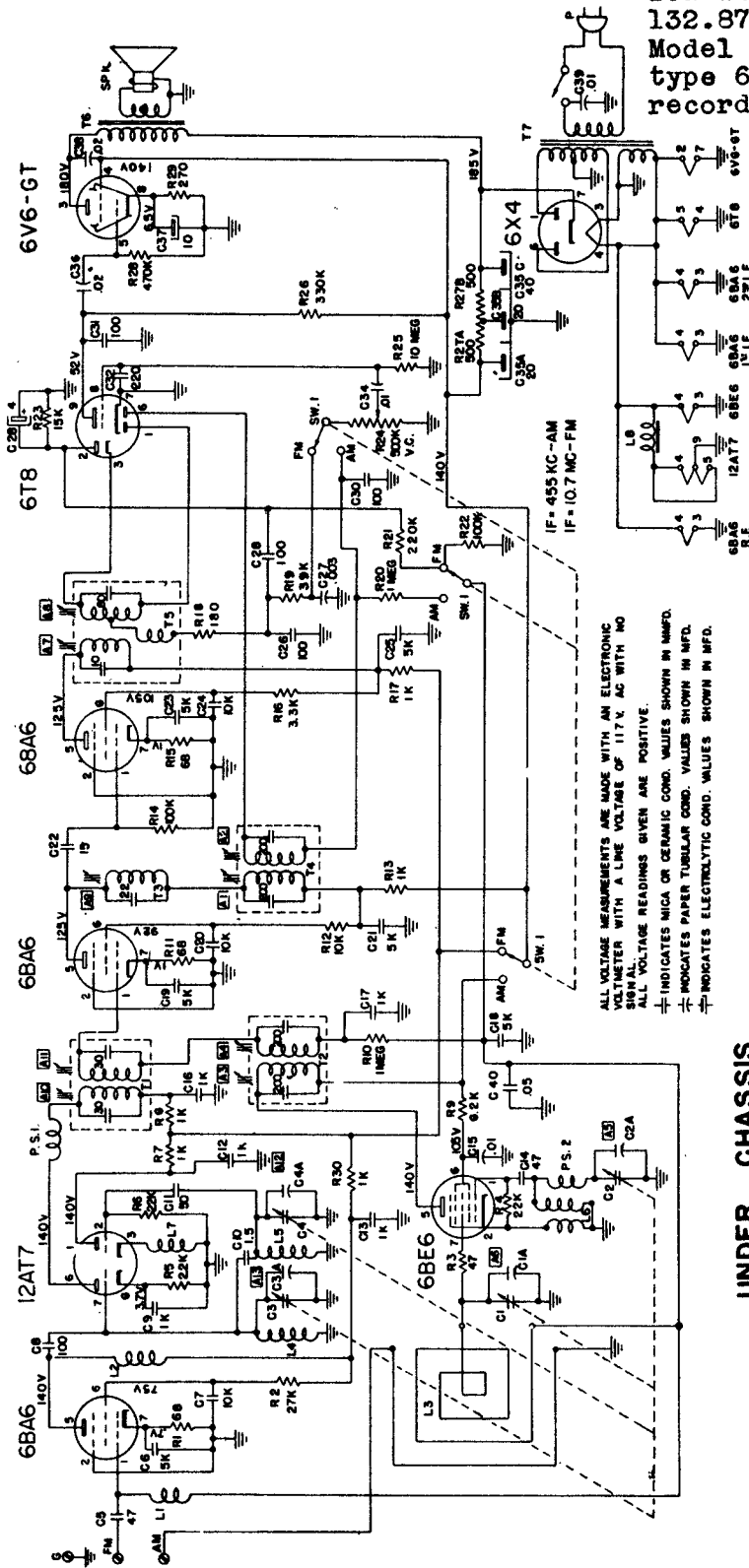

Figure 48.

MANUAL OF 1950 MOST-OFTEN-NEEDED RADIO DIAGRAMS

Sears, Roebuck and Co. Chassis 132.877, Catalog Nos. 18 and 20
(Alignment information is given on the next page)

You will find Model 9022, Chassis 132.871 almost identical; while Model 9105, Chassis 132.875 uses type 6AQ5 output tube and has a record changer.



ALL VOLTAGE MEASUREMENTS ARE MADE WITH AN ELECTRONIC VOLT-METER WITH A LINE VOLTAGE OF 117 V. AC WITH NO SIGNAL.
ALL VOLTAGE READINGS GIVEN ARE POSITIVE.
+ INDICATES MICA OR CERAMIC COND. VALUES SHOWN IN MFD.
- INDICATES PAPER TUBULAR COND. VALUES SHOWN IN MFD.
+ INDICATES ELECTROLYTIC COND. VALUES SHOWN IN MFD.

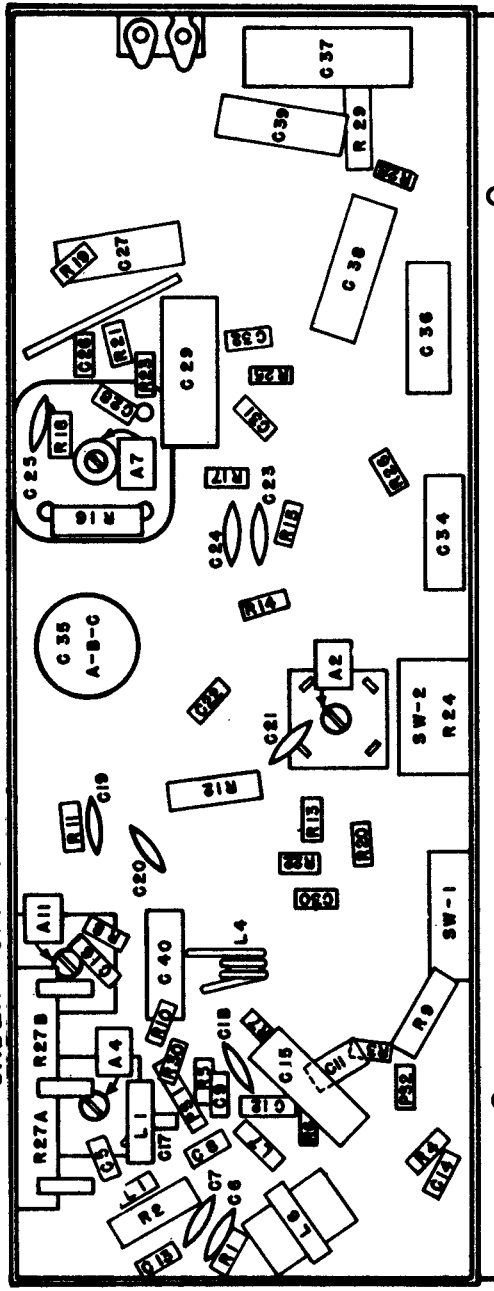

UNDER CHASSIS

MANUAL OF 1950 MOST-OFTEN-NEEDED RADIO DIAGRAMS.

Sears, Roebuck and Co. Chassis 132.877, Catalog Nos. 18 and 20.

AM ALIGNMENT

Position of Variable	Generator Frequency	Dummy Ant.	Generator Connection	Generator Connection	Adjust Trimmer In Order Shown For Max. Output	Trimmer Function
Open	455 Kc	.05 mfd.	Mixer Grid	Ground Lead	A1, A2, A3, A4,	I.F.
Open	1650 Kc		°Test Loop	Chassis	A5	Oscillator
1400 Kc	1400 Kc		°Test Loop	Test Loop	A6	Antenna
°°600 Kc	600 Kc		°Test Loop	Test Loop	Check Point	Antenna

* Connect generator lead to a Standard Hazeltine Test Loop, Model 1150, placed two feet from the set loop, or three turns of wire about six inches in diameter, placed about one foot from the set loop. Or the generator can be connected with the high side lead to the AM antenna screw terminal and the ground lead to the chassis.

** With a generator signal of 600 Kc, tune the set to the point where maximum output is obtained, which should be approximately 600 Kc on the dial. Adjust antenna section places of variable for maximum output.

FM ALIGNMENT

Detector and I.F. alignment using Signal Generator and Oscilloscope.

1. Connect FM Generator, High side, to grid (pin 1) of 6BA6 2nd I.F. tube through .005 mfd. dummy.
2. Set generator frequency to 10.7 Mc. modulated either 60 cycles or 400 cycles, 250 Kc sweep (125 Kc. deviation).
3. Connect vertical input of scope across volume control of receiver (grounded terminal to chassis, ungrounded terminal to high side of control).
4. Set scope switch for internal synchronization and set horizontal oscillator to 2X frequency of modulating voltage of generator. (120 or 800 cycles)
5. Turn variable condenser fully open, and band switch to right (FM).
6. Adjust frequency vernier of horizontal oscillator on scope until the pattern becomes stationary.
7. Adjust ratio detector primary slug No. A7 for maximum vertical sweep of the scope pattern.
8. Adjust ratio detector secondary slug No. A8 to center the cross over point of the pattern. Pattern should look like Fig. 1, with the same amount of curve on both ends, and the cross over point in the center.
9. Connect generator, high side, to center antenna screw terminal on bottom of chassis.
10. Adjust I.F. slugs A9, A10 and All for the greatest vertical sweep of the pattern, consistent with linearity. If the I.F. slugs are adjusted for maximum sweep of the pattern, the pattern may become non-linear. Therefore, adjustment should be made for the greatest sweep which can be obtained and still have all four ends of the "X" pattern similar in size and shape.
11. Check the alignment of the I.F. and detector circuits by varying the signal generator frequency above and below the center frequency of 10.7 Mc. If the receiver is perfectly aligned, two smaller "X" patterns of similar size and shape will result, one on either side of the center frequency. See Figure 2.

X PATTERN
CENTER FREQUENCY

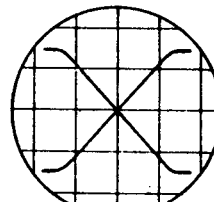

FIG 1

SMALL X PATTERN
ABOVE AND BELOW
CENTER FREQUENCY

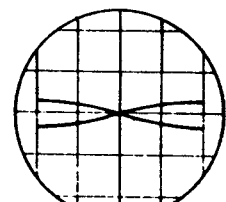

FIG 2

RF

Position of Variable	Generator Frequency	Dummy Ant.	Generator Connection	Generator Connection	Adjust Trimmers In Order Shown	Trimmer Function
Fully Open	108.5 Mc.	*300 ohm	High Side Ant. (FM)	Ground (C) Terminal	A12	Oscillator
Fully Closed	87.5 Mc.	*300 ohm	Ant. (FM) Terminal	Ground (C) Terminal	Check Point	Oscillator
105 Mc.	105 Mc.	*300 ohm	Ant. (FM) Terminal	Ground (C) Terminal	A13	R.F.
91 Mc.	91 Mc.	*300 ohm	Ant. (FM) Terminal	Terminal	Check Point	R.F.

For R.F. alignment use FM generator signal modulated with 400 cycles 45 Kc. sweep (22.5 Kc.) deviation.

* The 300 ohm dummy should be made up to two 150 ohm resistors, one placed in each lead at the receiver antenna terminals

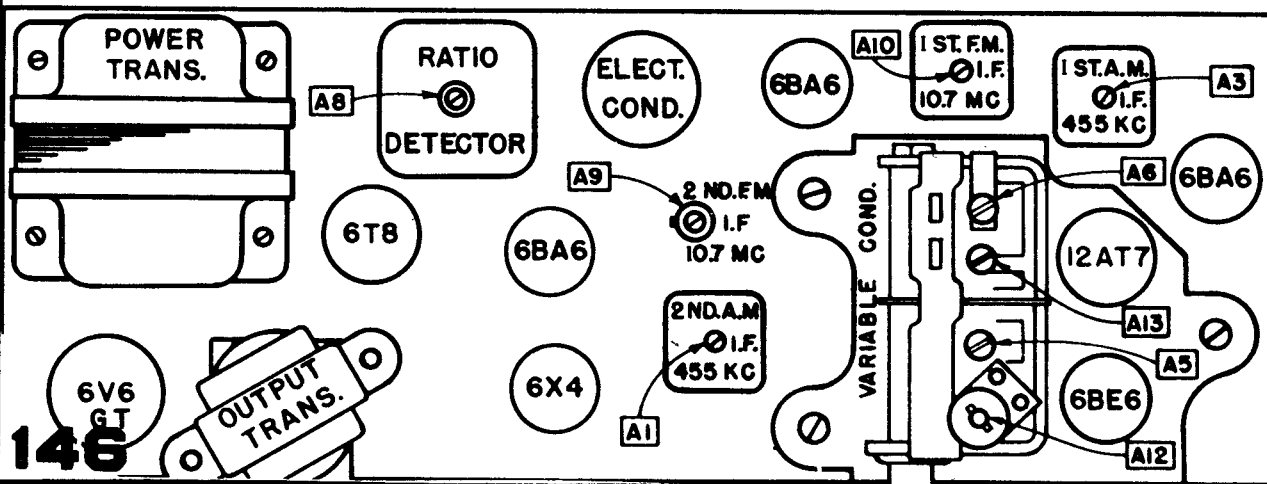

MANUAL OF 1950 MOST-OFTEN-NEEDED RADIO DIAGRAMS

Sears, Roebuck and Co. Chassis 132.878, Catalog Nos. 1 & 2

Silvertone

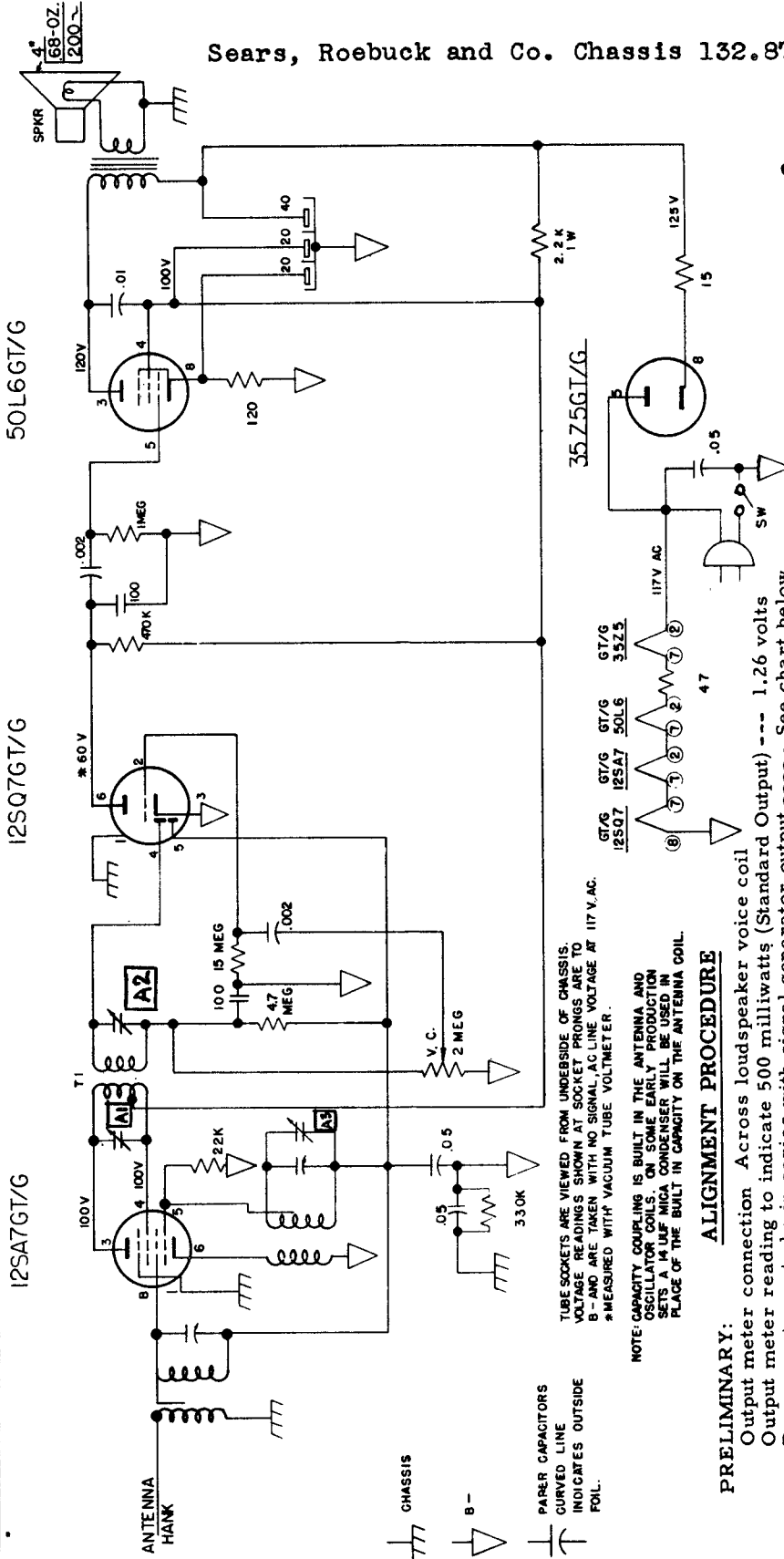

TUBE SOCKETS ARE VIEWED FROM UNDERSIDE OF CHASSIS. VOLTAGE READINGS SHOWN AT SOCKET PRONGS ARE TO B - AND ARE TAKEN WITH NO SIGNAL, AC LINE VOLTAGE AT 117 V. AC. * MEASURED WITH VACUUM TUBE VOLTMETER.

NOTE: CAPACITY COUPLING IS BUILT IN THE ANTENNA AND OSCILLATOR COILS. ON SOME EARLY PRODUCTION SETS A .14 U.F. MICA CONDENSER WILL BE USED IN PLACE OF THE BUILT IN CAPACITY ON THE ANTENNA COIL.

ALIGNMENT PROCEDURE

PRELIMINARY:
 Output meter connection Across loudspeaker voice coil
 Output meter reading to indicate 500 milliwatts (Standard Output) --- 1.26 volts
 Dummy antenna to be in series with signal generator output --- See chart below
 Connection of generator ground lead --- Floating ground
 Generator modulation --- 30% 400 cycles
 Position of Volume Control --- Fully clockwise

Position of Variable	Generator Frequency	Dummy Antenna	Generator Output Connection	Trimmers Adjusted	Trimmer Function	Approximate Sensitivity
Open	455 Kc	.05 uf	12SA7 Grid (Stator of C-1)	A1 A2	IF	4000 uv.
1400 Kc	1400 Kc		Antenna Lug with hank removed	**A3	Oscillator	500 uv.

** Since the antenna section of the variable has no trimmer, the rotor of the variable should be rocked back and forth on both sides of 1400 Kc while adjusting the oscillator trimmer for maximum output. This is to obtain the combination of rotor and trimmer setting to give perfect tracking of the two sections of the variable condenser and consequently give maximum output. Check sensitivity at 600 Kc. If weak, adjust antenna section plates for maximum output at 600 Kc. Tracking of the condenser at points other than 1400 Kc is accomplished by bending the outside plates on the variable condenser rotor, which are cut for this purpose.

MANUAL OF 1950 MOST-OFTEN-NEEDED RADIO DIAGRAMS.

Sears, Roebuck and Co. Chassis 135.244, Catalog No. 9073

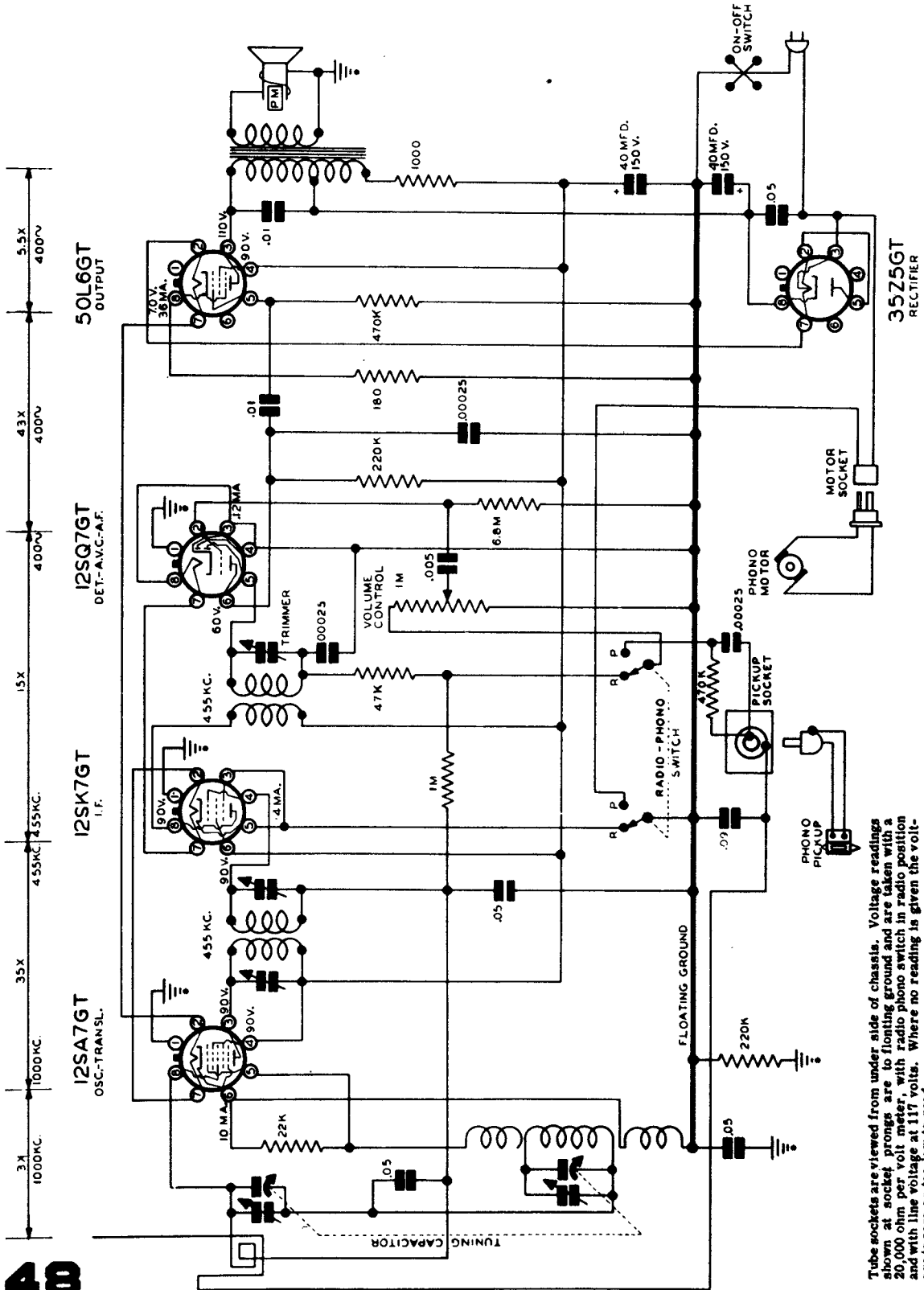

SCHEMATIC DIAGRAM FOR 135.244

Tube sockets are viewed from under side of chassis. Voltage readings shown at socket prongs are to floating ground and are taken with a 20,000 ohm per volt meter, with radio phono switch in radio position and with line voltage at 117 volts. Where no reading is given the voltage is zero or too low to read.

M=1,000,000 ohms.
K=1,000 ohms.

MANUAL OF 1950 MOST-OFTEN-NEEDED RADIO DIAGRAMS

Sentinel Radio

MODELS
312PW, 312PG, 1U312PW,
1U312PG

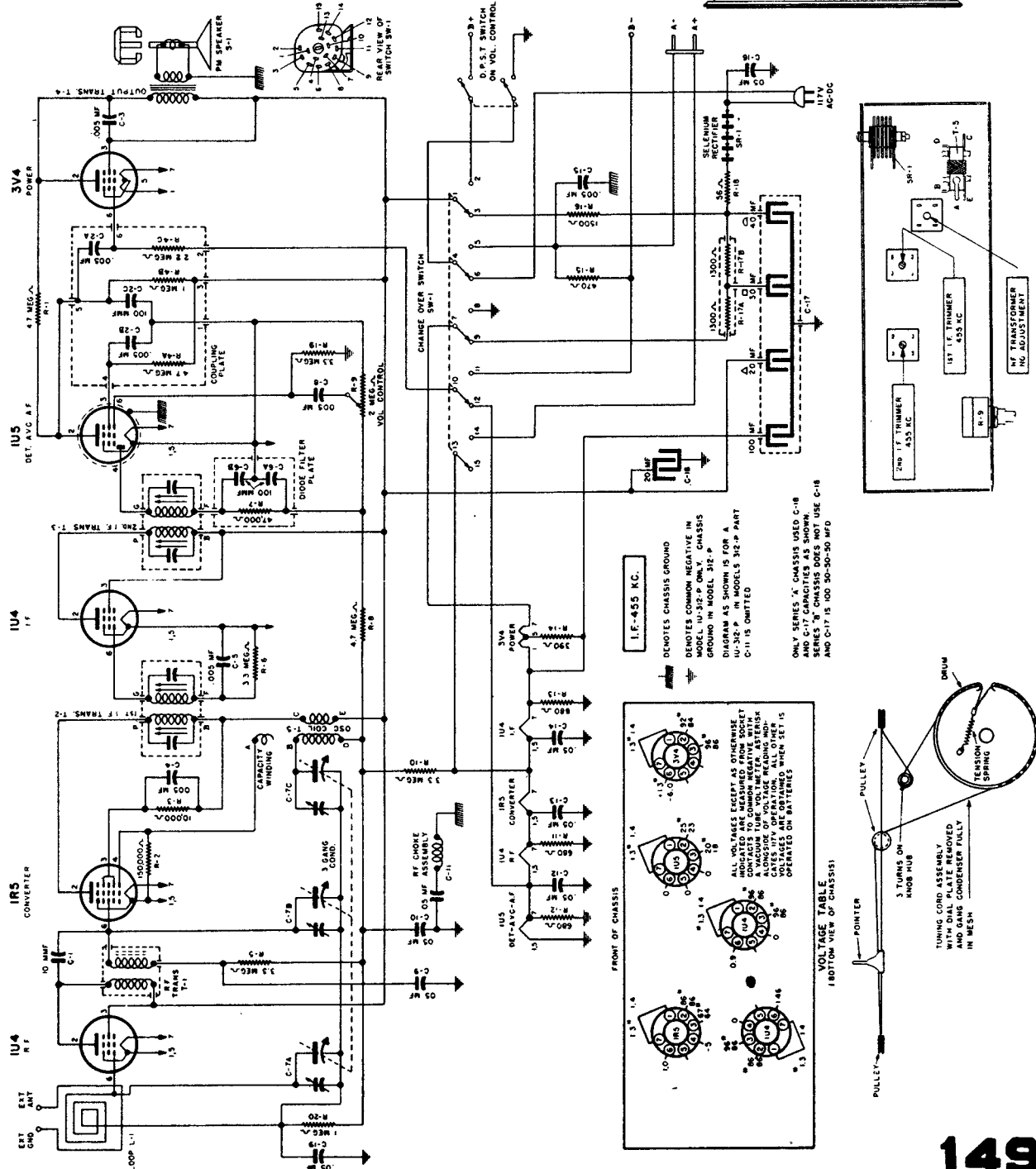
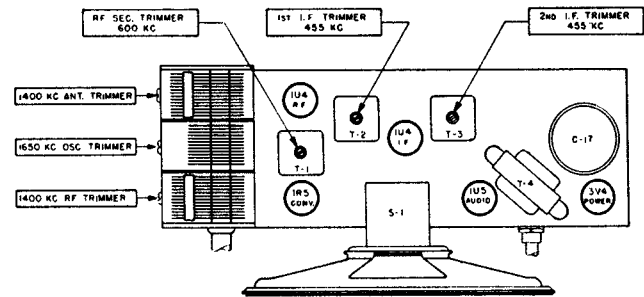

1400 KC ANT. TRIMMER
650 KC OSC. TRIMMER
1400 KC RF TRIMMER
1ST I.F. TRIMMER 455 KC
2ND I.F. TRIMMER 455 KC

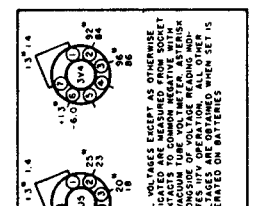

VOLTAGE TABLE
(BOTTOM VIEW OF CHASSIS)

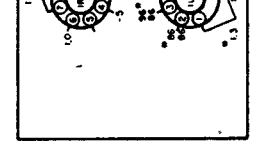

3V4 POWER
1U5 DET. AVC AF
1U4 I.F.
IRS CONVERTER
1U4 I.F.
1U5 DET. AVC AF
PM SPEAKER 3-1
D.P.S.T. SWITCH ON VOL. CONTROL
CHARGE OVER SWITCH SW-1
SELENIUM
C-15
C-16
C-17
C-18
C-19
C-20
C-21
C-22
C-23
C-24
C-25
C-26
C-27
C-28
C-29
C-30
C-31
C-32
C-33
C-34
C-35
C-36
C-37
C-38
C-39
C-40
C-41
C-42
C-43
C-44
C-45
C-46
C-47
C-48
C-49
C-50
C-51
C-52
C-53
C-54
C-55
C-56
C-57
C-58
C-59
C-60
C-61
C-62
C-63
C-64
C-65
C-66
C-67
C-68
C-69
C-70
C-71
C-72
C-73
C-74
C-75
C-76
C-77
C-78
C-79
C-80
C-81
C-82
C-83
C-84
C-85
C-86
C-87
C-88
C-89
C-90
C-91
C-92
C-93
C-94
C-95
C-96
C-97
C-98
C-99
C-100

1.5V
1.4
1.3
1.2
1.1
1.0
0.9
0.8
0.7
0.6
0.5
0.4
0.3
0.2
0.1
0.0

1.5V
1.4
1.3
1.2
1.1
1.0
0.9
0.8
0.7
0.6
0.5
0.4
0.3
0.2
0.1
0.0

1.5V
1.4
1.3
1.2
1.1
1.0
0.9
0.8
0.7
0.6
0.5
0.4
0.3
0.2
0.1
0.0

MANUAL OF 1950 MOST-OFTEN-NEEDED RADIO DIAGRAMS

Sentinel Radio

MODELS 331-W, 331-I, 331-R
AC-DC SUPERHETERODYNE RECEIVER

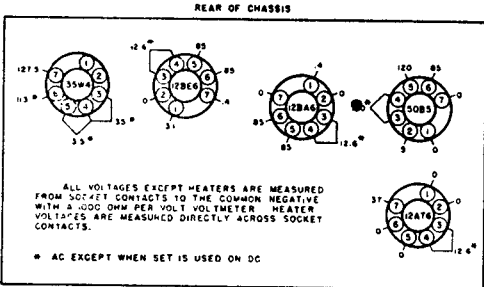
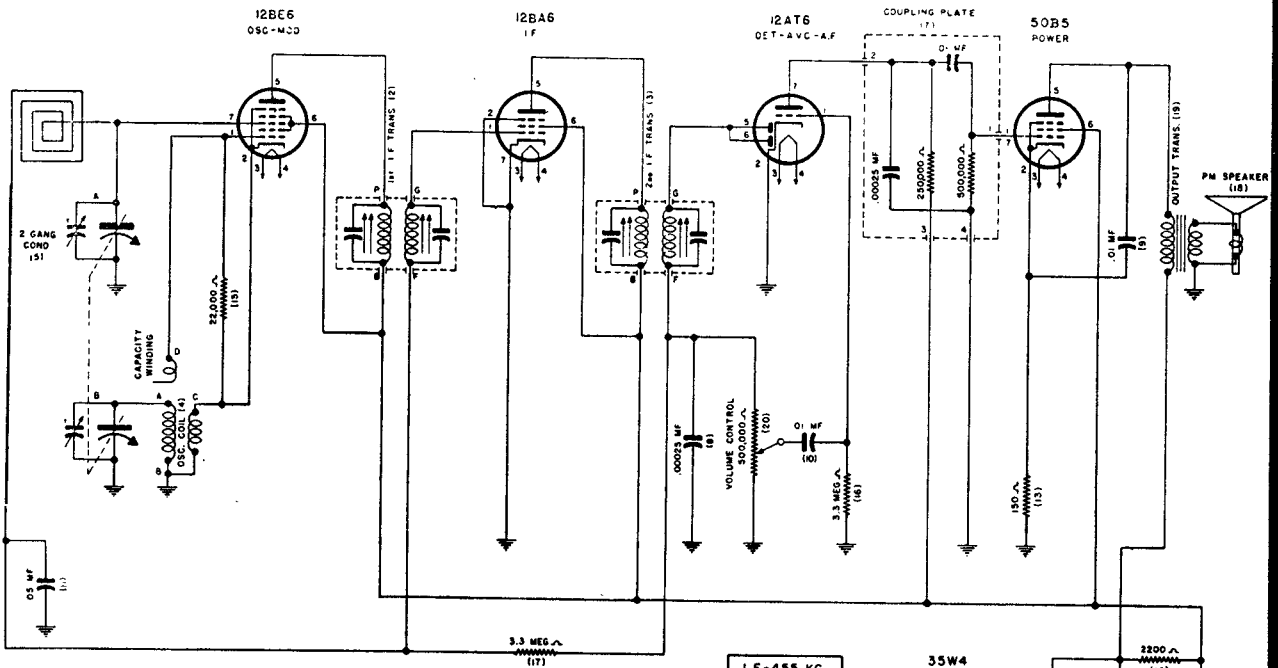
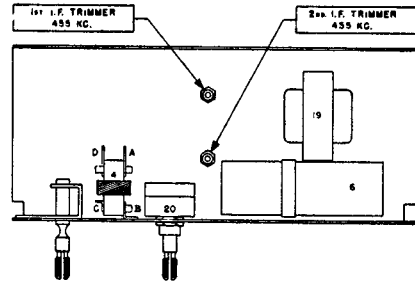
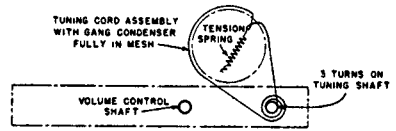
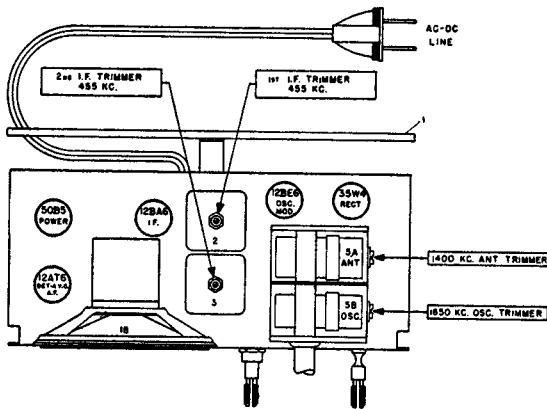

NOTE: NUMBERS SHOWN IN PARENTHESES ARE ILLUSTRATION NUMBERS

ALL VOLTAGES EXCEPT HEATERS ARE MEASURED FROM SOCKET CONTACTS TO THE COMMON NEGATIVE WITH A 1000 OHM PER VOLT VOLTMETER. HEATER VOLTAGES ARE MEASURED DIRECTLY ACROSS SOCKET CONTACTS.

* AC EXCEPT WHEN SET IS USED ON DC

150

VOLTAGE TABLE* (BOTTOM VIEW OF CHASSIS)

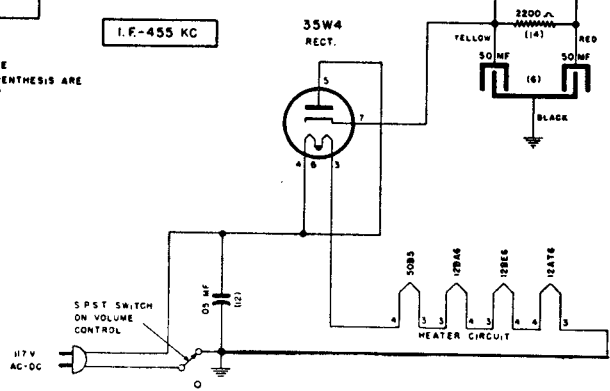

MANUAL OF 1950 MOST-OFTEN-NEEDED RADIO DIAGRAMS

REAR OF CHASSIS

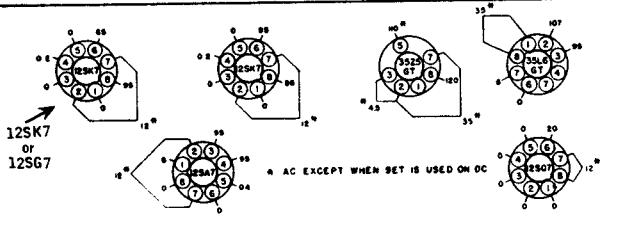

12SK7
or
12SG7

NOTE - ALL VOLTAGES EXCEPT HEATERS ARE MEASURED FROM SOCKET CONTACTS TO THE COMMON NEGATIVE WITH A 1000 OHM PER VOLT VOLTMETER. HEATER VOLTAGES ARE MEASURED DIRECTLY ACROSS SOCKET CONTACTS.

VOLTAGE TABLE
(BOTTOM VIEW OF CHASSIS)

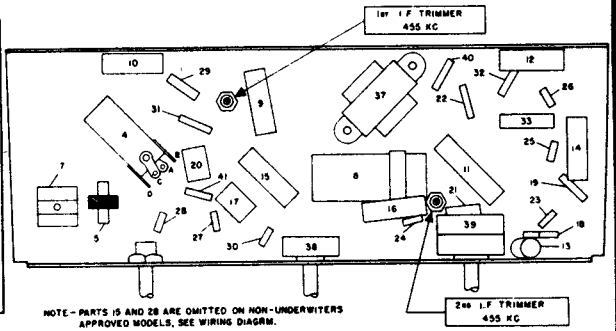
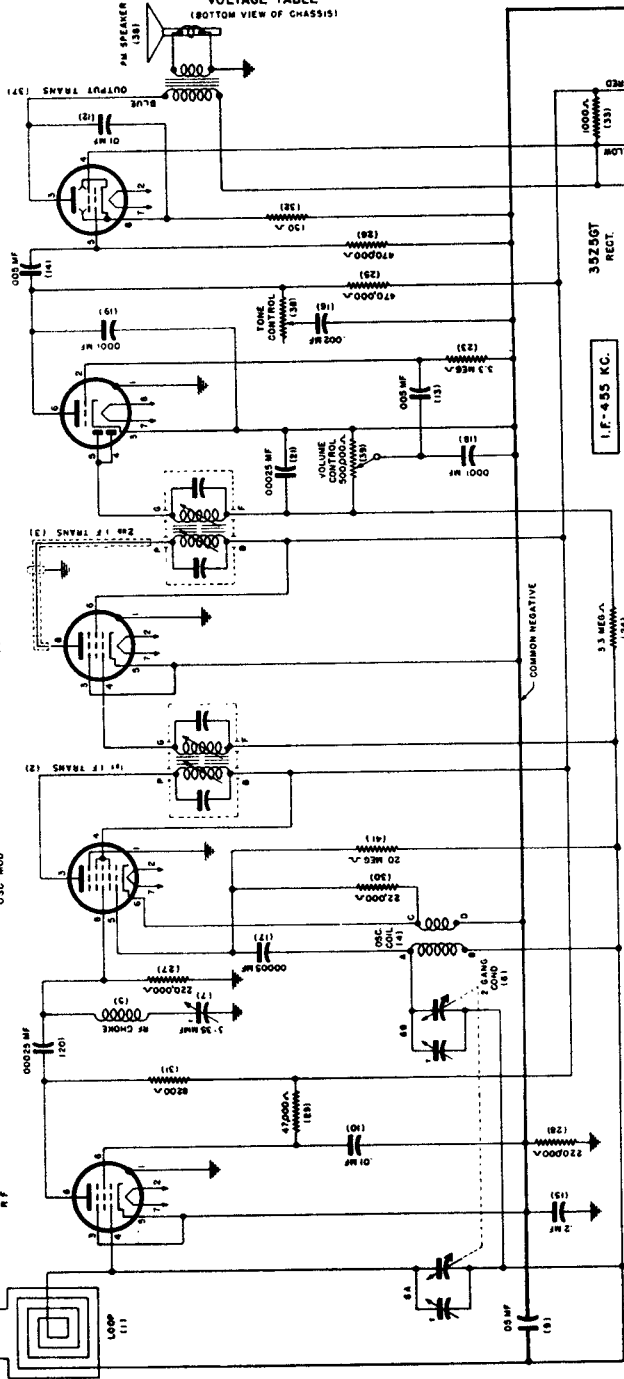

NOTE - PARTS 15 AND 28 ARE OMITTED ON NON-UNDERWRITERS APPROVED MODELS, SEE WIRING DIAGRAM.

NOTE: NUMBERS SHOWN IN PARENTHESIS ARE ILLUSTRATION NUMBERS

UNDERWRITERS APPROVED MODELS HAVE A COMMON NEGATIVE. NON-UNDERWRITERS APPROVED MODELS DO NOT HAVE A COMMON NEGATIVE AND ALL CONNECTIONS TO THE COMMON NEGATIVE ARE GROUNDING DIRECTLY TO THE CHASSIS.

EXTENSION LINE CORDS
480V- 230V (134)
38V- 125V (133)

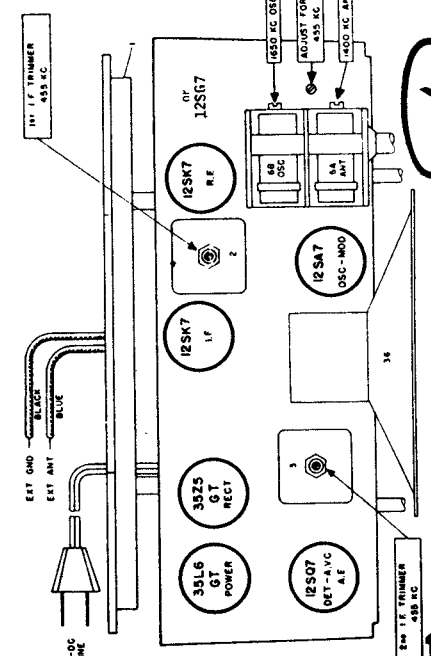
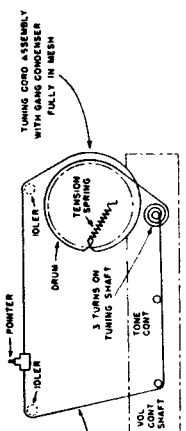

Sentinel Radio MODELS 332W and 332-I

MANUAL OF 1950 MOST-OFTEN-NEEDED RADIO DIAGRAMS

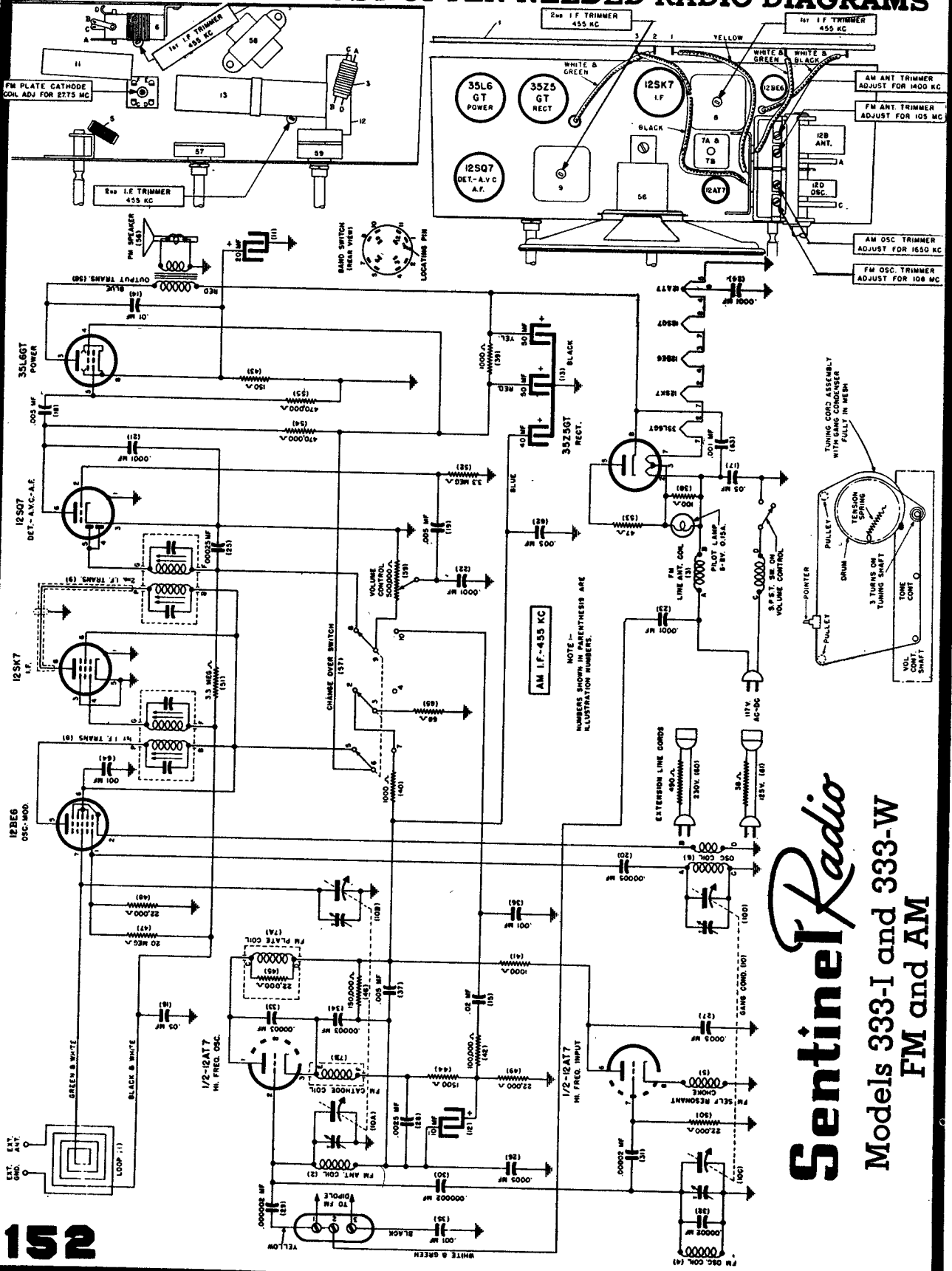

Sentinel Radio
 Models 333-I and 333-W
 FM and AM

Sentinel Radio

Models 333-I and 333-W
FM and AM

AM ALIGNMENT PROCEDURE

Before starting alignment:

- Check tuning dial adjustment by tuning gang condenser until plates touch maximum capacity stop (completely in mesh) at which point the dial pointer must be exactly even with the last line at the low frequency end of the AM dial calibration. If dial needle does not point exactly to last line move to correct position.
- Use an accurately calibrated test oscillator with some type of output measuring device.
- Place loop antenna in the same position it will be in when set is in the cabinet.

Steps	TEST OSCILLATOR				Refer to parts layout diagram for location of trimmers mentioned below:	
	Place band switch for operation on:	Set receiver dial to:	Adjust test oscillator frequency to:	Use dummy antenna in series with output of test oscillator consisting of:		Attach output of test oscillator to:
1	AM Band position	Any point where no interfering signal is received	Exactly 455 K. C.	0.2 Mfd. Condenser	High side to A.M.-Osc. stator plates of tuning condenser (107). Low side to frame of condenser through .01 Mfd. condenser.	Adjust each of the 2nd 455 K. C. AM I. F. transformer trimmers for maximum output, then adjust each of the 1st 455 K. C. AM I. F. transformer trimmers for maximum output.
2	AM Band position	Exactly 1730 K.C.	Exactly 1730 K.C.		Receiver blue antenna lead Receiver black ground lead	Adjust 1730 K. C. oscillator trimmer for maximum output.
3	AM Band position	Approx. 1400 K. C.	Approx. 1400 K. C.		Receiver blue antenna lead Receiver black ground lead	Adjust 1400 K. C. AM Ant. trimmer for maximum output.

FM ALIGNMENT

The only portion of this receiver which is used during FM reception, other than the AF and Power Supply, is the 12AT7 Dual Triode tube and its associated circuits. One triode of the tube is used for HF Oscillator and covers a band 27.75 MC above the 88 to 108 FM Band. The other triode is used for Rf Input, Super-regenerator and Detector. This triode oscillates at 27.75 MC and is quenched by an RC network at about 25 KC.

In tuning this receiver on FM, it will be noticed that two signals will be received with a null point between them. These two signals will be substantially equal in tone and volume and either one can be used. They represent the frequency discrimination which takes place due to the receiver being tuned to one side of the carrier center frequency and this, therefore, is not the spot of greatest quieting. Greatest quieting is found at the null point, at which no frequency discrimination takes place and therefore no audio signal is produced.

The equipment necessary for FM alignment consists of the following:

- An Audio Output Meter.
- An AM or FM Signal Generator that will supply a 27.75 MC, 105 MC and 108 MC signal.

ALIGNMENT PROCEDURE

- Connect Output Meter across voice coil of speaker.
- Remove jumper wire from terminals #1 and #2 on loop terminal strip.
- Connect the hot Signal Generator lead through a 300 Ohm Resistor to the #1 post on terminal strip and the other lead to the post marked #3.

27.75 MC PLATE COIL ADJUSTMENT

- Set Signal Generator to deliver a modulated 27.75 MC Signal.
- Adjust 27.75 MC Plate Coil Trimmer for maximum reading on Output Meter.

108 MC and 105 MC ADJUSTMENT

- Set Signal Generator to deliver a modulated 108 MC signal.
- Tune receiver dial to MINIMUM CAPACITY STOP.
- Adjust 108 MC Oscillator Trimmer for maximum reading on Output Meter.
- Tune receiver dial and Signal Generator to 105 MC.
- Adjust 105 MC Antenna Trimmer for maximum reading

MANUAL OF 1950 MOST-OFTEN-NEEDED RADIO DIAGRAMS

Sentinel

MODELS 335PM,
335PW, 335PI, 335PG, 1U-335PM,
1U-335PW, 1U-335PI, 1U-335PG

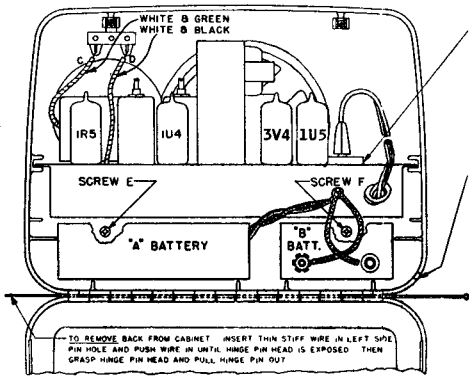

FOR BATTERY OPERATION THE AC LINE CORD PLUG MUST BE FIRMLY INSERTED INTO THIS RECEPTACLE

TO REMOVE CHASSIS FROM CABINET
1. REMOVE BATTERIES.
2. UNSOLDER ANTENNA WIRES C AND D.
3. REMOVE SCREWS E AND F.

FOR AC-DC OPERATION, OPEN BACK, PLACE LINE CORD IN NOTCH AND CLOSE BACK

TO REMOVE BACK FROM CABINET: INSERT THIN STIFF WIRE IN LEFT SPIRE PIN HOLE AND PUSH WIRE IN UNTIL HINGE PIN HEAD IS EXPOSED. THEN GRASP HINGE PIN HEAD AND PULL HINGE PIN OUT.

TO INSTALL BACK ON CABINET: LINE UP CABINET HINGE HOLES WITH BACK HINGE HOLES, INSERT HINGE PIN AND PUSH THROUGH HOLES.

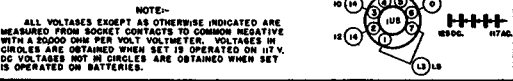
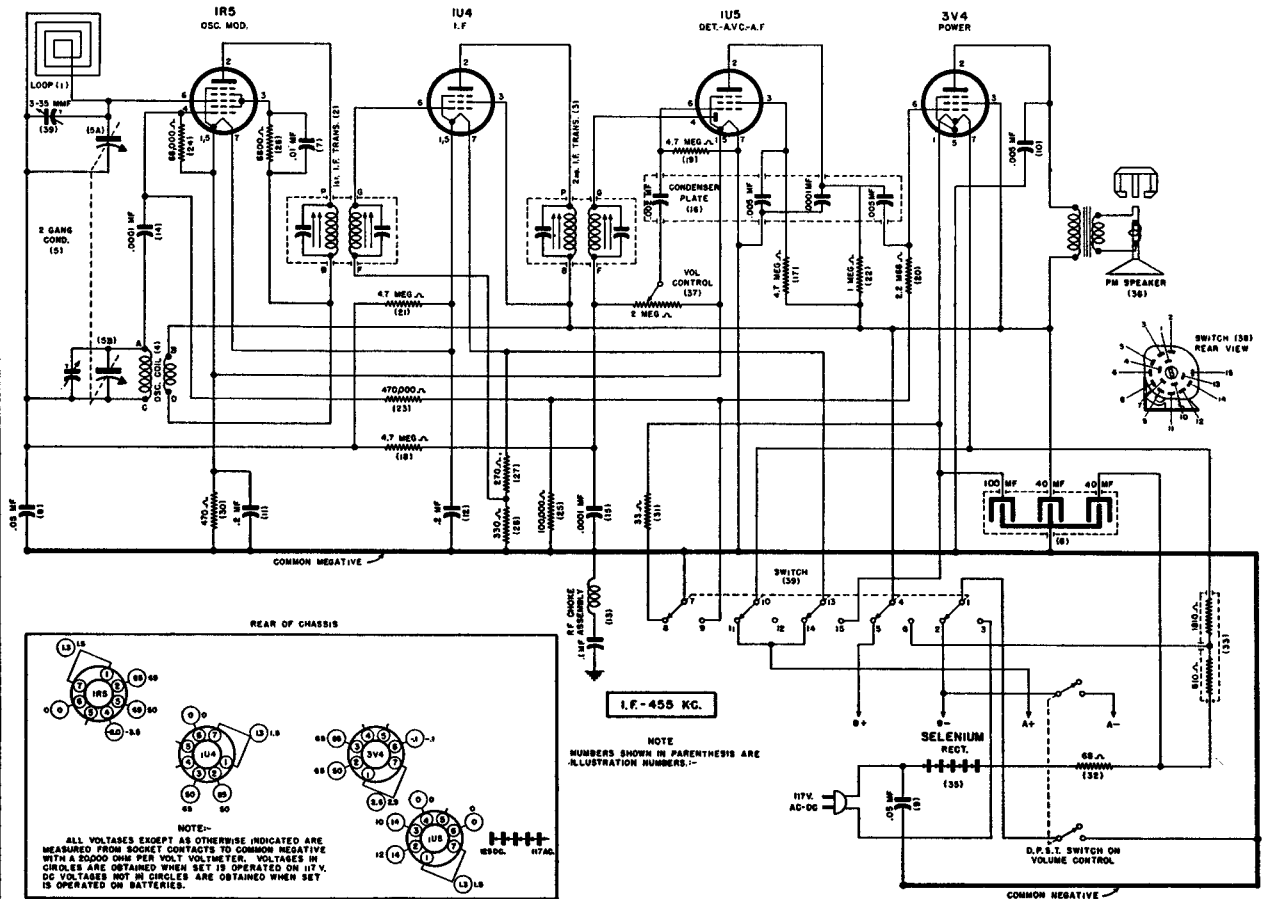
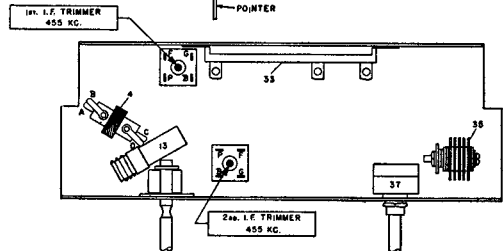
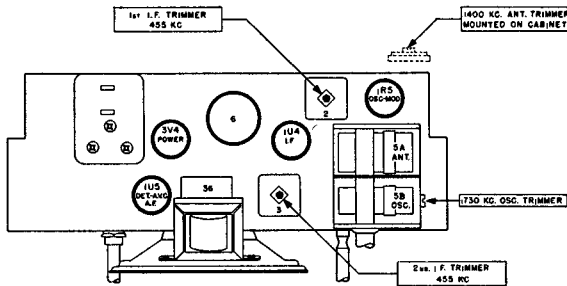
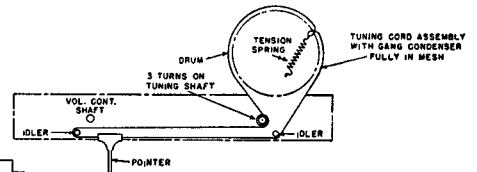

VOLTAGE TABLE
(BOTTOM VIEW OF CHASSIS)

MANUAL OF 1950 MOST-OFTEN-NEEDED RADIO DIAGRAMS

Sentinel Radio Models 339-K and 1U339-K Alignment Procedure

- (A) Check tuning dial adjustment by tuning gang condenser until plates touch maximum capacity stop (completely in mesh) at which point the dial needle must be exactly even with the last line at the low frequency end of the dial calibration. If the dial needle does not point exactly to the last line move to correct position by holding dial needle shank at the point where it attaches to its drum while turning the drum on the gang condenser.
- (B) Use an accurately calibrated test oscillator with some type of output measuring device.
- (C) **THE LOOP MAY BE LEFT IN THE CABINET** and the chassis with its mounting board pulled out of the cabinet just far enough for adjustment of the trimmers, or the loop and chassis may be removed from the cabinet and the loop placed in the same position and plane it will be in when both are mounted in cabinet—approximately 1" space between receiver loop and chassis. Couple test oscillator to receiver loop by: (1) make loop consisting of 5 to 10 turns of No. 20 to No. 30 size wire, wound on a 2" or 3" form; (2) connect this loop across output of test oscillator; (3) place test oscillator loop near radio loop. **BE SURE THAT NEITHER LOOP MOVES WHILE ALIGNING.**

Steps	Set receiver dial to:	TEST OSCILLATOR			Refer to parts layout diagram for location of trimmers mentioned below:
		Adjust test oscillator frequency to:	Use dummy antenna in series with output of test oscillator consisting of:	Attach output of test oscillator to:	
1	Any point where no interfering signal is received	455 K. C.	.02 MFD. See Paragraph (C) Above	High side to rear stator plates of tuning condenser. Low side to chassis (common negative in 1U339K) through a .02 Mfd. blocking condenser.	Adjust each of the second I. F. transformer trimmers for maximum output—then adjust each of the first I.F. trimmers for maximum output.
2	Exactly 1650 K. C.	Exactly 1650 K. C.	See Paragraph (C) Above	See Paragraph (C) Above	Adjust 1650 K. C. oscillator trimmer for maximum output.
3	Approx. 1400 K. C.	Approx. 1400 K. C.	See Paragraph (C) Above	See Paragraph (C) Above	Adjust 1400 K. C. antenna trimmer for maximum output.

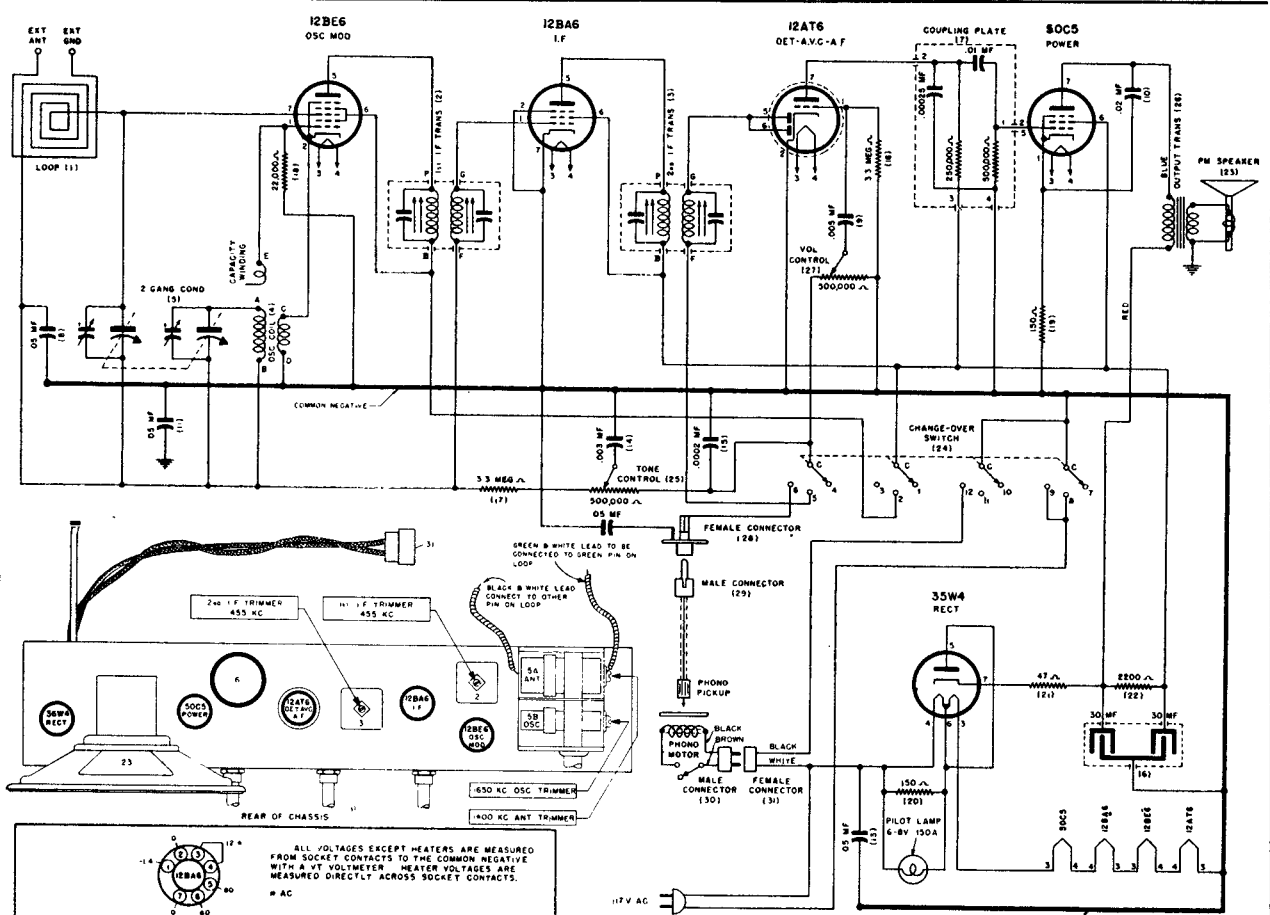

ALL VOLTAGES EXCEPT HEATERS ARE MEASURED FROM SOCKET CONTACTS TO THE COMMON NEGATIVE WITH A V.T. VOLTMETER. HEATER VOLTAGES ARE MEASURED DIRECTLY ACROSS SOCKET CONTACTS.

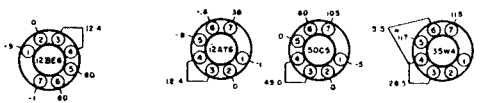

VOLTAGE TABLE (BOTTOM VIEW OF CHASSIS)

Sentinel

339-K AND 1U339-K 155

MANUAL OF 1950 MOST-OFTEN-NEEDED RADIO DIAGRAMS

Sonora Radio & Television Corp.

12AV6
CONVERTER

12AV6
PROC.-AUDIO

50C5
OUTPUT

Models 299 (Walnut)
and 300 (Ivory).

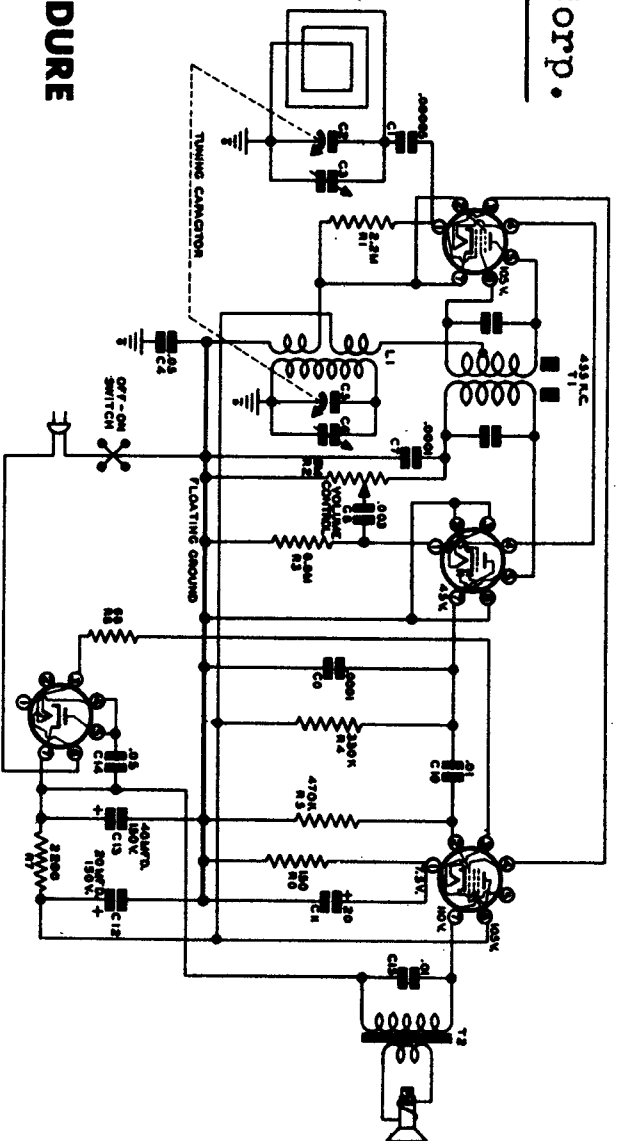

ALIGNMENT PROCEDURE

Step No.	Position of Gang	Signal Generator Frequency	Generator Connection	Dummy Antenna	Adjustment	Type of Adjustment
1.	Open	455 KC.	Rear Gang Terminal	.1 Mfd.	Slugs Top and Bottom in can.	Adjust for Maximum Output
2.	Open	1620 KC.	Dummy	2 Turns of Hookup Wire 6" in Dia. (Place Approx. a Foot from and in Same Plane as Loop)	Front Gang Trimmer	Adjust for Maximum Output
3.	1400 KC	1400 KC	Antenna		Rear Gang Trimmer	Adjust for Maximum Output
4.	600 KC	600 KC			—	Check Gang Alignment

Schematic Location	Sonora Part No.	DESCRIPTION
C1	N-6985	Condenser, Ceramic 50 M.M.F.D. 500V.
C4	N-1945	Condenser, Paper .05 M.F.D. 200V.
C7, C9	N-6015	Condenser, Ceramic 100 M.M.F.D. 500V.
C8	N-2063	Condenser, Paper .003 M.F.D. 600V.
C10, C15	N-1944	Condenser, Paper .01 M.F.D. 400V.
C11	N-7153	Electrolytic { 20 M.F.D. 15V.
C12		{ 20 M.F.D. 160V.
C13		{ 40 M.F.D. 150V.
C14	N-1346	Condenser, Paper .05 M.F.D. 400V.
R1	N-4277	Resistor 2.2 Megohm 1/2 W 20% Volume Control—2.0 Megohm
R2	N-7142	Resistor 6.8 Megohm 1/2 W 20%
R3	N-4028	Resistor 330,000 Ohm 1/2 W 20%
R4	N-4423	Resistor 470,000 Ohm 1/2 W 20%
R5	N-4027	Resistor 180 Ohm 1/2 W 10%
R6	N-4067	Resistor 2,200 Ohm 1/2 W 10%
R7	N-4896	Resistor 68 Ohm 2.0W 10%
R8	N-6014	Transformer, I.F.
T1	N-7694	Oscillator Coil
L1	N-7725	Loop Antenna Coil
	N-7670	Variable Capacitor
	N-7141	Speaker, 4" PM with Output Transformer
	N-7824	

ALIGNMENT PROCEDURE

ALIGNMENT PROCEDURE

STEP NO.	POSITION OF GANG	SIGNAL GENERATOR FREQUENCY	GENERATOR CONNECTION	DUMMY ANTENNA	TYPE OF ADJUSTMENT	ADJUSTMENT
1.	OPEN	455 K.C.	REAR GANG TERMINAL.	.1MFD.	T2, C9 & C8	ADJUST FOR MAXIMUM OUTPUT
2.	OPEN	1620 K.C.	LOOP	.0002 MFD.	FRONT GANG TRIMMER	ADJUST FOR MAXIMUM OUTPUT
3.	1400 K.C.	1400 K.C.	LOOP	.0002 MFD.	REAR GANG TRIMMER	ADJUST FOR MAXIMUM OUTPUT
4.	600 K.C.	600 K.C.	LOOP	.0002 MFD.		CHECK GANG ALIGNMENT

Sonora Radio

Model 306

DESCRIPTION

Capacitor - Electrolytic - 40 MFD. 150 V., 40 MFD. 150 V.

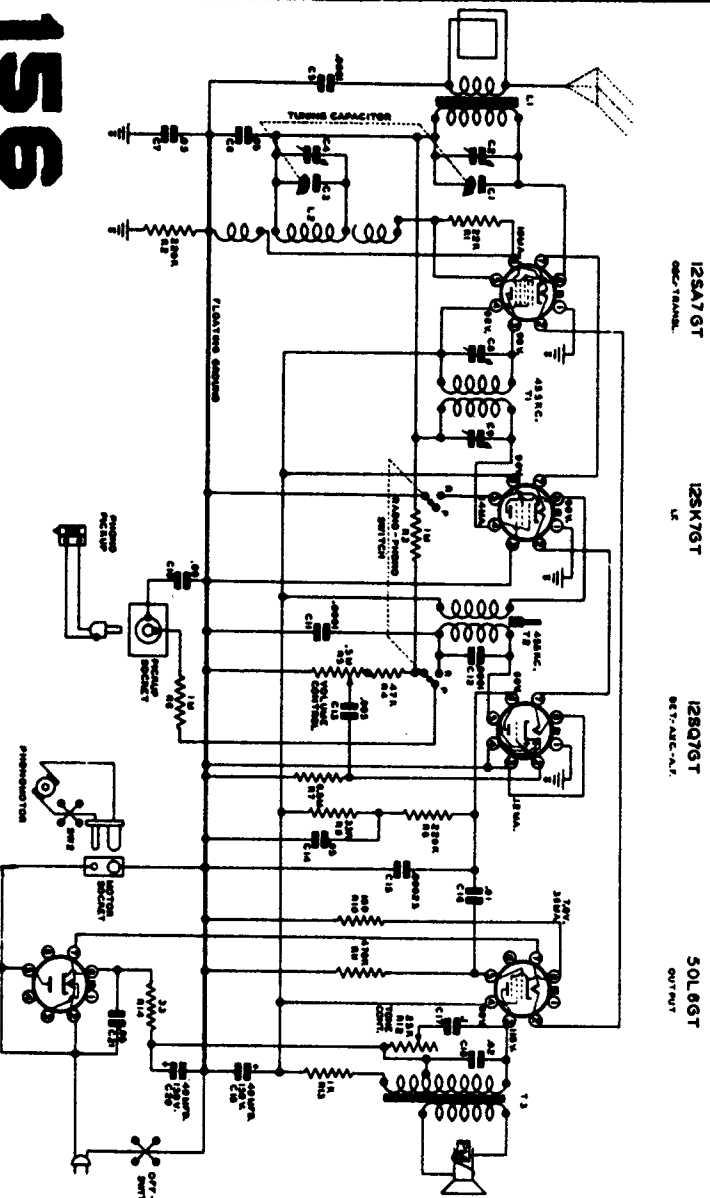

- C5, C11 Capacitor - Ceramic 100 MMFD. 500V. 20%
- C12 Capacitor - Ceramic 100 MMFD. 500V. 10%
- C15 Capacitor - Ceramic 250 MMFD. 500V. 20%
- C13 Capacitor - Paper .005 MFD. 500V. 20%
- C16 Capacitor - Paper .01 MFD. 400V.
- C18 Capacitor - Paper .02 MFD. 400V.
- C6, C7, C14 Capacitor - Paper .05 MFD. 200V.
- C21 Capacitor - Paper .05 MFD. 400V.
- C10 Capacitor - Paper .09 MFD. 200V.
- C17 Capacitor - Paper .1 MFD. 400V.

* Control - On-Off & Volume

- R5 Control - Tone
- R12 Resistor - 33 Ohm - 1/2W. 20%
- R14 Resistor - 180 Ohm - 1/2W. 10%
- R10 Resistor - 22,000 Ohm - 1/2W. 20%
- R1 Resistor - 33,000 Ohm - 1/2W. 20%
- R9 Resistor - 47,000 Ohm - 1/2W. 20%
- R4 Resistor - 220,000 Ohm - 1/2W. 20%
- R11 Resistor - 470,000 Ohm - 1/2W. 20%
- R3, R6 Resistor - 1.0 Megohm - 1/2W. 20%
- R13 Resistor - 1,000 Ohm - 1.0W. 10%

- T1 Transformer - I.F. #1
- T2 Transformer - I.F. #2
- T3 Transformer - Output

MANUAL OF 1950 MOST-OFTEN-NEEDED RADIO DIAGRAMS

(FM) I.F. 10.7 MC.
(AM) I.F. 455 KC.

STEWART-WARNER AM-FM RADIO MODEL 9151-A

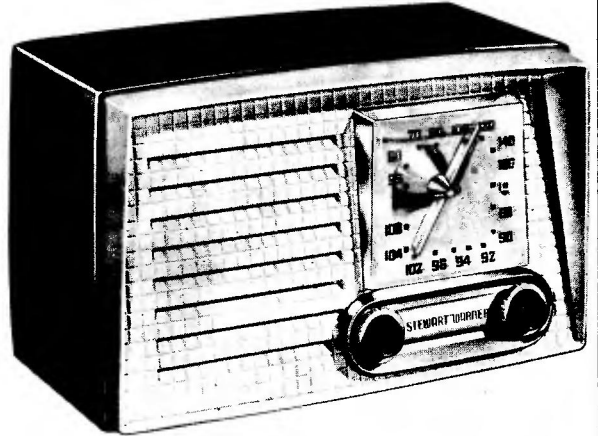

HOW TO REMOVE CHASSIS FROM CABINET

1. Remove all knobs by pulling them forward.
2. Take off dial scale by pressing down on top center of plastic dial enclosure and at the same time pulling it forward.
3. Remove pointer by pulling it forward.
4. Remove cabinet back by taking out three screws and two clips.
Note: Cabinet back has a power cord interlock which is automatically disconnected when back is removed.
5. Take out two chassis mounting screws at bottom of cabinet. Chassis may now be readily removed by sliding it out of cabinet.
6. When replacing cabinet back be sure that it is parallel to loop and power cord interlock plug fits into socket on chassis.

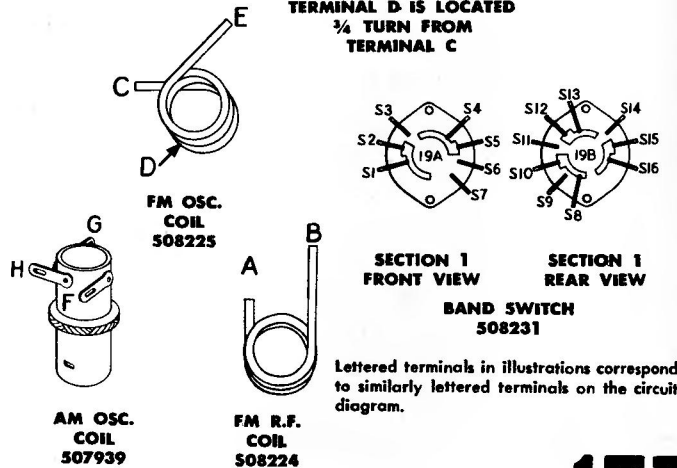
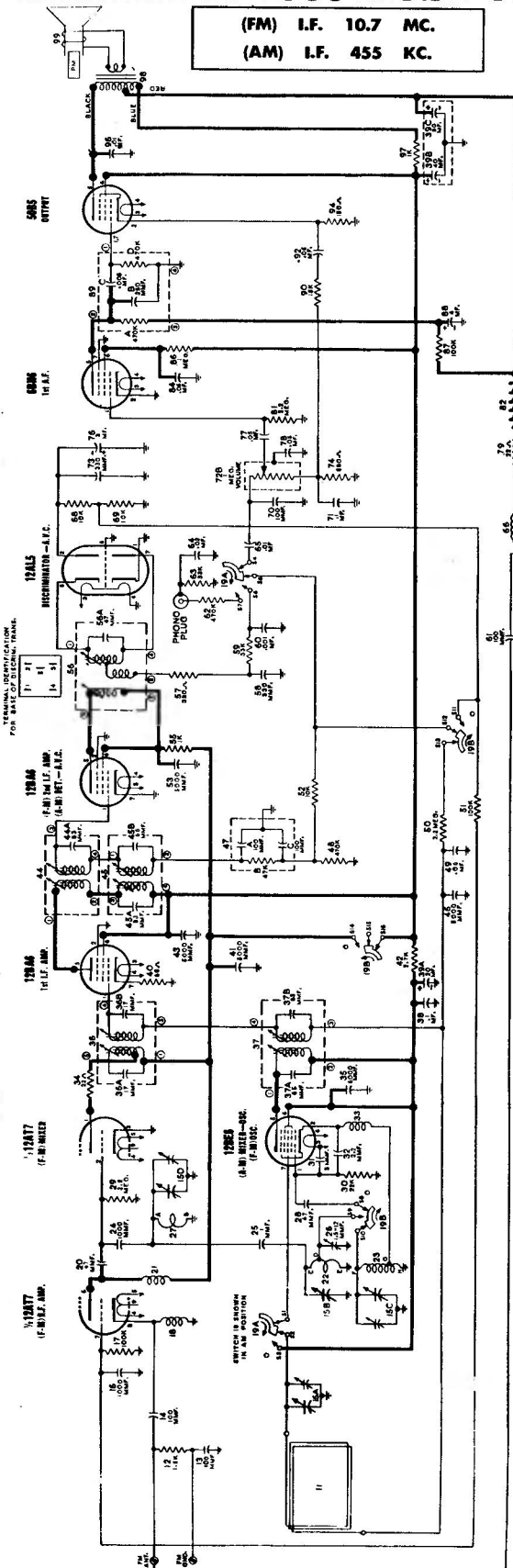

MANUAL OF 1950 MOST-OFTEN-NEEDED RADIO DIAGRAMS

Stewart-Warner Model 9151-A, Continued

BROADCAST BAND—"AM"—ALIGNMENT PROCEDURE

1. If alignment of both AM and FM channels are required, it is advisable to align the AM channel first; then align the FM channel as instructed on Page 159.
2. Remove chassis and loop antenna (which is mounted to chassis) from cabinet by following procedure outlined on Page 157. Allow loop to remain attached to chassis.
3. In order to provide a coupling for signal generator during R.F. alignment as instructed in chart below, wind several turns of wire in a circular shape so that it may be placed adjacent and parallel to the loop.
4. Connect an output meter across the speaker voice coil or from the plate of the 50B5 tube to chassis through a 0.1 Mfd. condenser.
5. Set band switch to the "AM" (counter-clockwise) position.
6. Set volume control at maximum and use a weak signal from the signal generator.
7. Since the dial scale is a part of the cabinet, when completely assembled, it becomes necessary to provide a temporary means of locating the dial to obtain calibration points. Rotate gang condenser fully counter-clockwise and replace painter so that it is **parallel** with base of the chassis. Now, hold dial scale in front of painter in such a position that the ends of the indicator point to the "AM" and "FM" markers. While holding the dial scale in this position, rotate tuning sleeve until painter indicates desired frequency.

SIGNAL GENERATOR CONNECTIONS		SIGNAL GENERATOR FREQUENCY	RECEIVER DIAL SETTING	TRIMMER OR SLUG NUMBER	TRIMMER DESCRIPTION	TYPE OF ADJUSTMENT
CONNECT HIGH SIDE OF SIGNAL GENERATOR TO	CONNECT GROUND LEAD OF SIGNAL GENERATOR TO					
Lug on trimmer #6 at top of gang (see figure 1 for location of trimmer).	Chassis ground. CAUTION: If your signal generator is designed with an AC-DC type power supply, connect ground lead of signal generator to receiver chassis through a .25 Mfd. condenser.	455 KC	Any point where it does not affect the signal.	1 and 2	2nd I.F.	Adjust for maximum output. Then repeat adjustment.
				3 and 4	1st I.F.	
Connect directly to coupling turn. See Step 3 above for instruction on coupling loop.		1500 KC	1500 KC See Step 7 above for instructions on how to obtain this calibration point.	5	AM Oscillator	Adjust for maximum output.
Connect directly to coupling turn. See Step 3 above for instruction on coupling loop.		1500 KC	Tune to 1500 Kc. generator signal.	6	AM Antenna	Adjust for maximum output.

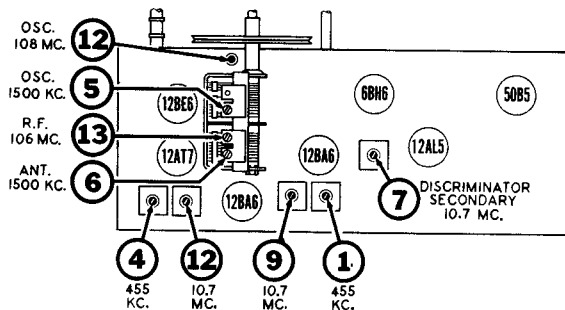
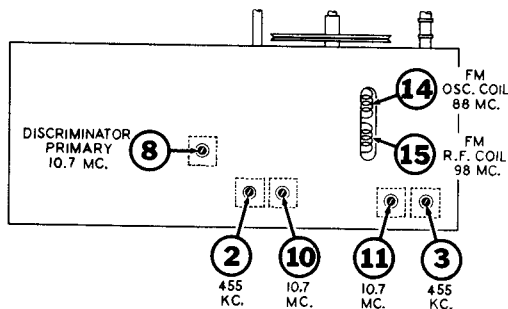

FIG. 1 Top View of Chassis



Bottom View of Chassis

FIG. 2

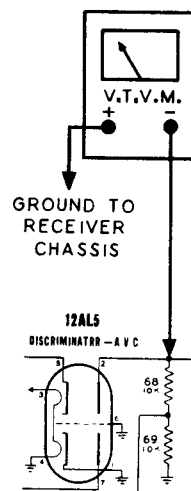

FIG. 3
VTVM Connections
for IF Alignment

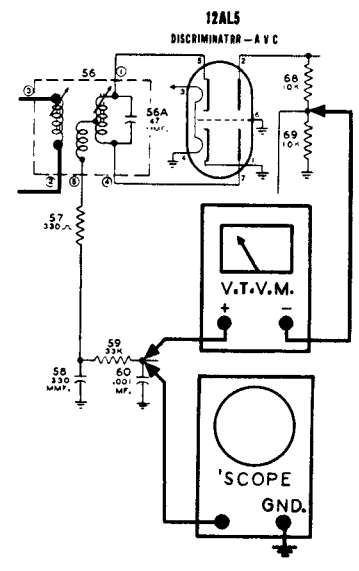

FIG. 4
VTVM and Oscilloscope
Connections for
Discriminator Alignment

MANUAL OF 1950 MOST-OFTEN-NEEDED RADIO DIAGRAMS

Stewart-Warner Model 9151-A, Continued

FREQUENCY MODULATION—"FM"—ALIGNMENT PROCEDURE

1. If alignment of both AM and FM channels are required it is advisable to align the AM channel first as instructed in chart on Page 158. Then, accomplish FM channel alignment by using the procedure outlined in the chart below.
2. Remove chassis and loop antenna (which is mounted to chassis) from cabinet by following procedure outlined on Page 157. Allow loop to remain attached to chassis.
3. Disconnect built-in FM lead from "FM ANT." terminal at back of chassis.
4. Set band switch to the "FM" (middle) position.
5. Set volume control at maximum and use a weak signal from the signal generator.
6. Dress FM circuit leads as short and straight as possible, particularly those in the oscillator circuit. IF plate and grid leads should also be kept short and straight.
7. Since the dial scale is a part of the cabinet, when completely assembled, it becomes necessary to provide a temporary means of locating the dial to obtain calibration points. Rotate gang condenser fully counter-clockwise and replace pointer so that it is **parallel** with base of the chassis. Now, hold dial scale in front of pointer in such a position that the ends of the indicator point to the "AM" and "FM" markers. While holding the dial scale in this position, rotate tuning sleeve until painter indicates desired frequency.

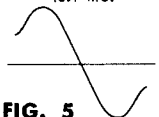
STANDARD SIGNAL GENERATOR		SWEEP GENERATOR		VTVM OR OUTPUT METER CONNECTION	OSCILLOSCOPE CONNECTIONS	RECEIVER DIAL SETTING	TRIMMER OR SLUG NUMBER	TYPE OF ADJUSTMENT AND OUTPUT INDICATION
CONNECTIONS	FREQUENCY	CONNECTIONS	FREQ.					
Connect high side to lug on trimmer #13 (see Fig. 1 for location of trimmer) using a .01 Mfd. condenser in series with generator lead. Connect ground lead to the receiver chassis in vicinity of gang condenser. CAUTION: If your signal generator is designed with an AC-DC type power supply, connect ground lead of signal generator to receiver chassis through a .25 Mfd. condenser.	10.7 MC. Unmodulated	Not used.	————	Connect VTVM as shown in Fig. 3.	Not used.	Any position where it does not affect the signal.	#7 Discriminator secondary #8 Discriminator primary #9-10 2nd IF #11-12 1st IF	Adjust these trimmers for maximum meter reading — the output voltage will be of negative polarity. Note that as slug #7 is rotated, a point will be found where the voltmeter will swing rather sharply from a positive to a negative reading or vice versa. The correct setting is obtained when the meter reads zero as the slug is moved thru this point.
Same as above.	Same as above.	Not used.	————	Connect VTVM as shown in Fig. 4.	Not used.	Same as above.	#7 Discriminator secondary	A pattern similar to that shown in Fig. 5 should appear on the oscilloscope screen. Check for symmetry about the 10.7 Mc. center point and linearity of the slope. 10.7 MC.  FIG. 5 If the characteristic is not shaped properly, attempt to obtain symmetry by changing the setting of slug #7. Should that fail to produce the desired results, then a slight re-adjustment of slugs #8, 9, 10, 11 and 12 should be undertaken.
Same as above.	Same as above. Attenuate signal to prevent overload and distortion of response curve.	Connect high side to lug on trimmer #13 (see Fig. 1 for location of trimmer) using a .01 Mfd. condenser in series with generator lead. Connect ground lead to the receiver chassis in vicinity of gang condenser. CAUTION: If your signal generator is designed with an AC-DC type power supply, connect ground lead of signal generator to receiver chassis through a .25 Mfd. condenser.	10.7 MC Sweeping ±300 Kc.	Not used.	Connect as shown in Fig. 4. Set vertical amplifier of 'scope for maximum amplification. Synchronize oscilloscope with sweep generator by connecting "horizontal input" terminals of 'scope to source of horizontal sweep modulating voltage on the sweep generator.	Same as above.	#7 Discriminator secondary	
Connect high side in series with a 270 ohm carbon resistor to "FM ANT." terminal at rear of chassis. Connect ground lead to "FM GND." terminal.	108 MC. with 400 cycle AM Modulation.	Not used.	————	Connect VTVM as shown in Fig. 3.	Not used.	108 Mc. See Step 7 above for instructions on how to obtain this calibration point.	#12 FM Oscillator	Set trimmer #12 to receive 108 Mc. signal as indicated by maximum meter reading.
Same as above.	108 MC. with 400 cycle AM Modulation.	Not used.	————	Same as above.	Not used.	Tune to 108 Mc. generator signal.	#13 FM RF	Adjust trimmer for maximum meter reading.

Check calibration and tracking of receiver with input signals of 88 and 98 MC. If difference between dial pointer setting and the above mentioned frequencies does not exceed ±0.3 MC, and RF circuit is tracking properly then alignment may be considered satisfactory and no further adjustment is necessary. Where the calibration error is greater than ±0.3 MC, it is advisable to make the following adjustments:
Tune receiver to an 88 MC. signal and note whether dial pointer is above or below correct calibration point. Then tune receiver so that dial pointer is at the 88 MC. position. If generator signal was previously received at a setting above 88 MC., it will be necessary to slightly spread the windings of the FM oscillator coil (#14 in Fig. 2) so that signal will now be received at the correct

dial setting. On the other hand, if generator signal was received at a dial setting below 88 MC., then slightly compress the windings of the oscillator coil until the signal comes in at the correct calibration point.
Check calibration at 108 MC. and if it is in error by more than ±0.3 MC., readjust setting of trimmer #12. Repeat calibration adjustment at 88 and 108 MC. until desired accuracy is obtained.
Observe dial calibration at 98 MC. If it is found to be incorrect by an appreciable amount, then make a very slight adjustment in the spacing of the gang condenser plates to receive the 98 MC. signal at the correct dial setting. Then check adjustment of RF trimmer #13 to obtain maximum output

50B5
OUTPUT

12AT6
2nd DET. - A.V.C. - A.F.

12BA6
I.F. AMP.

12BE6
CONVERTER

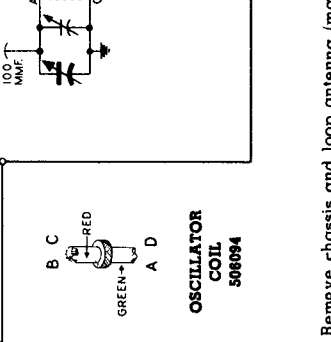
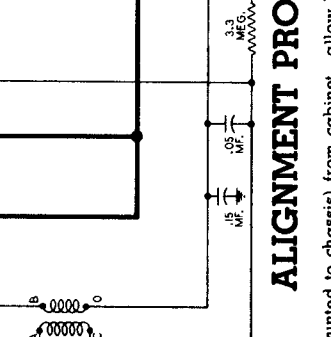
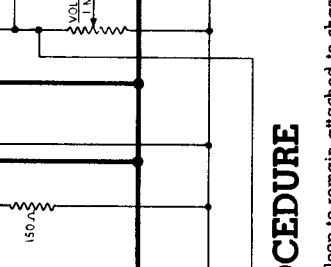
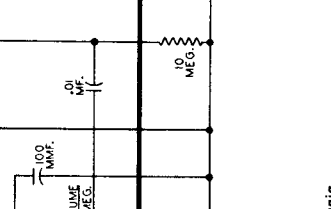
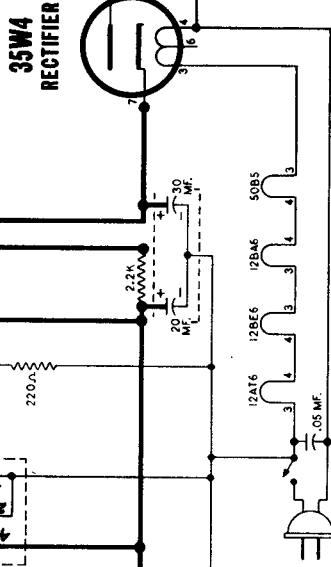

ALIGNMENT PROCEDURE

Remove chassis and loop antenna (mounted to chassis) from cabinet--allow loop to remain attached to chassis.

Replace the dial scale on the shaft of the gang condenser.

Since the "position indicator" for the dial scale is an integral part of the cabinet, it becomes necessary to install a "temporary pointer" when the chassis is removed from the cabinet. This can readily be accomplished by securing a piece of heavy wire under the right front gang condenser mounting screw and shaping the free end of the wire so that it can be placed in a vertical position directly in front of the dial scale. With the gang condenser fully meshed, the "temporary pointer" should appear directly in front of the fine line preceding "55" on the dial scale.

Couple the signal generator to the receiver by connecting its output to several turns of wire formed in a circular shape so that it may be placed adjacent and parallel to the receiver loop antenna.
Connect an output meter across the speaker voice coil or from the plate of the 50B5 tube to B--through a 0.1 Mfd. condenser.
Set volume control at maximum volume position and use a weak signal from the signal generator.

SOCKET VOLTAGES

Measured with voltmeter having sensitivity of 1000 ohms per volt except where indicated by (*).
The (°) symbol designates a vacuum tube volt-meter measurement.

LOOP ANTENNA TERMINALS SHORTED TOGETHER
VOLUME ON FULL WITH NO SIGNAL DIAL TUNED TO 540 KC.

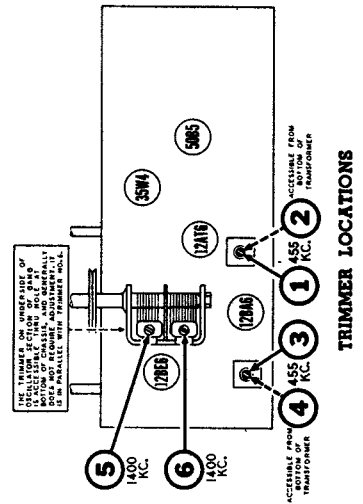
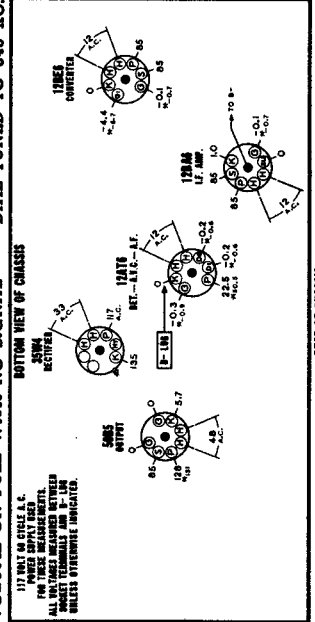

Courtesy Stewart-Warner Corp.

DRIVE CORD ARRANGEMENT

To string dial cord, turn the main drive drum to maximum counter, clockwise position and use following parts:
114955 Clip on end of cord
117057 Cord (2 feet)
505161 Tension Spring

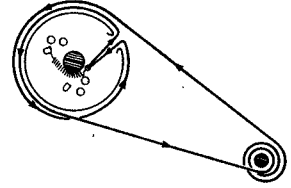

MANUAL OF 1950 MOST-OFTEN-NEEDED RADIO DIAGRAMS

STROMBERG-CARLSON SERVICE NOTES

RADIO RECEIVER - MODEL 1500

ALIGNMENT PROCEDURE

CAUTION: As this is a transformless Receiver, observe all usual precautions. The Black-White (B-) lead is common to one side of the 117 Volt Power Line Cord.

Pointer Setting	Generator Setting	Input and Dummy	VTVM and Scope Connection and Scale	Adj. and Notes
I. F. ADJUSTMENT				
(1) Low frequency end of dial	455 kc. 400 cy. mod.	Pin #7, 12BE6 tube 0.01 mfd. dummy	-3V DC Scale Green-White (AVC) lead and Black-White (B-) lead.	Adj. top and bottom cores of each I. F. transformer with non-metallic screwdriver for maximum voltage.
(2) " "	455 kc. Swept 15 kc.	" "	Scope to Junction C-6 and Volume Control	Adj. same cores as above for best over-lapping curve on scope.
R. F. ADJUSTMENT				
(1) 1650 kc. Condenser plates all way out	1650 kc. 400 cy. mod.	Ant. terminal 0.01 mfd. dummy	" "	Adj. Osc. (front) trimmer on variable condenser for maximum voltage.
(2) 1400 kc.	1400 kc. 400 cy. mod.	" "	" "	Adj. R. F. and Loop trimmers on variable condenser for maximum voltage.

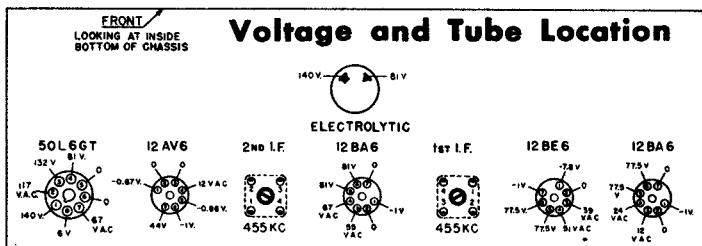
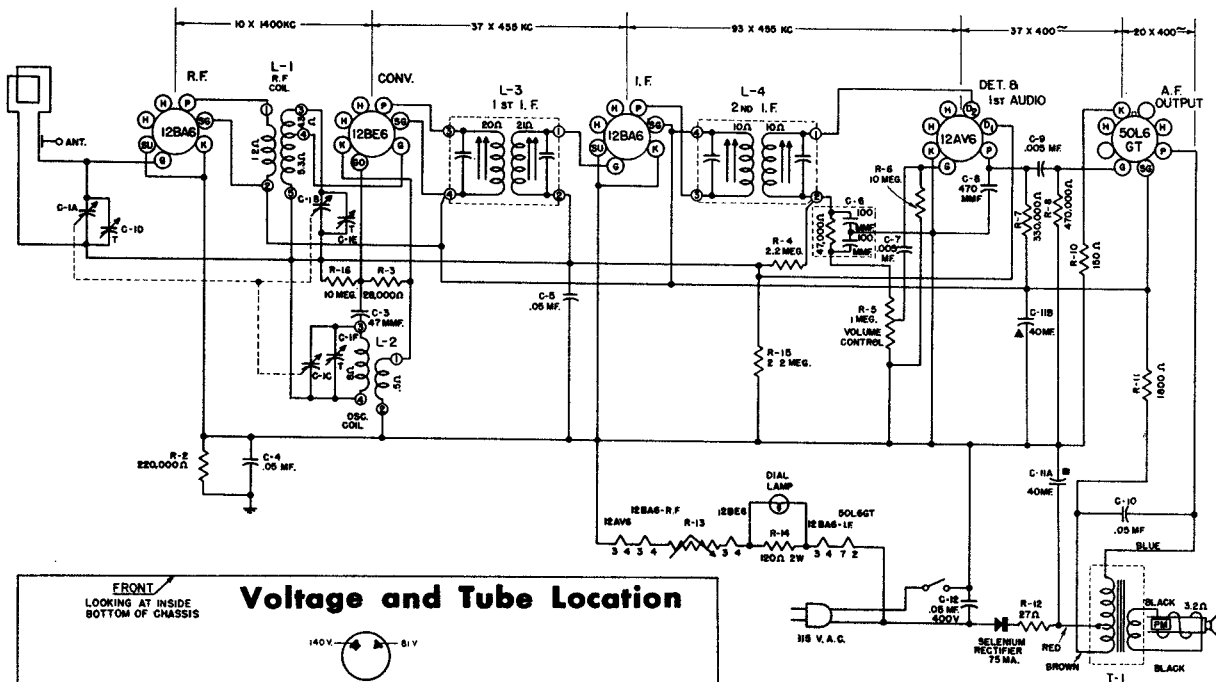

TUBE COMPLEMENT

- 2 12BA6 Miniature RF and IF Amplifier
- 1 12BE6 Miniature Converter
- 1 12AV6 Miniature Detector, AVC and Audio Driver
- 1 50L6GT Power Output

Measurements are made at 117V line, using electronic Voltmeter. Except where otherwise indicated, volages are D.C. and are positive with respect to the reference point which is the common Black-White lead.

MANUAL OF 1950 MOST-OFTEN-NEEDED RADIO DIAGRAMS

MODEL 5015



MODEL 5015

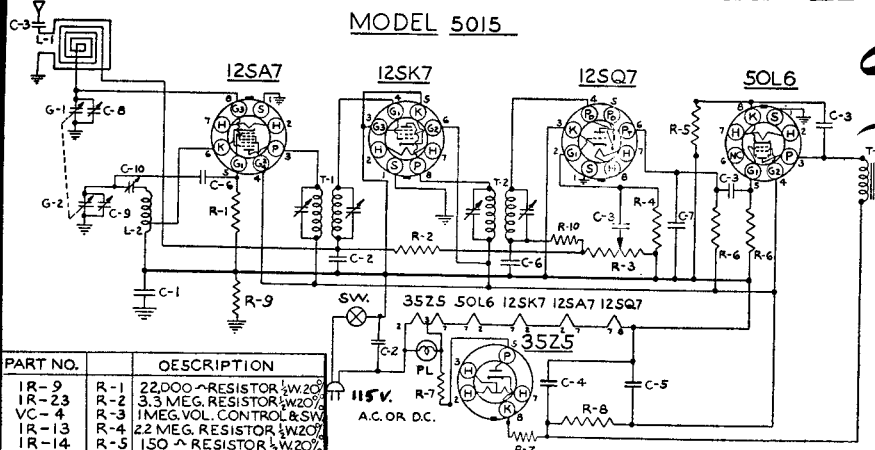

PART NO.	DESCRIPTION
IR-9	R-1 22,000-RESISTOR 1/2W 20%
IR-23	R-2 3.3 MEG. RESISTOR 1/2W 20%
VC-4	R-3 1 MEG. VOL. CONTROL & SW
IR-13	R-4 22 MEG. RESISTOR 1/2W 20%
IR-14	R-5 150 Ω RESISTOR 1/2W 20%
IR-11	R-6 470M Ω RESISTOR 1/2W 20%
IR-17	R-7 33 Ω RESISTOR 1/2W 20%
IR-25	R-8 2200 Ω RESISTOR 1/2W 10%
PC-8	R-9 1 MFD. COND. 400V.
PC-15	C-2 .05 MFD. COND. 400V.
PC-7	C-3 .01 MFD. COND. 400V.
EC-12	C-4 40 MFD. 150V. ELECTROLYTIC
MC-2	C-5 20 MFD.
MC-5	C-6 100MMFD. MICA COND.
MC-5	C-7 500MMFD. MICA COND.
IR-10	R-10 47M Ω 1/2 W 20 %

Model 5015

PART NO.	DESCRIPTION
TC-7	C-8 ANTENNA TRIMMER COND.
TC-6	C-9 OSC. TRIMMER COND.
TC-9	C-10 OSC. PADDING COND.
IR-20	R-9 220M Ω RESISTOR 1/2W 20%
GC-1	G-1 GANG CONDENSER
LL-4	L-1 LOOP ANTENNA
LO-7	L-2 OSC. COIL
LI-1	T-1 INPUT I.F. TRANSFORMER
LI-2	T-2 OUTPUT I.F. TRANSFORMER
T-3	OUTPUT SPKR. TRANSFORMER
SPK-6	V. C. VOICE COIL
PB-1	S P.M. SPEAKER
PL	NO. 47 PILOT BULB
SW.	AC. SW. ON VOL. CONTROL

ALIGNMENT

The receiver volume control should be turned to maximum during the I.F. and all subsequent alignments to keep the AVC from working and giving false readings. Keep the generator output as low as possible to prevent overloading.

FIRST STEP: Connect the hot lead from the generator to the ANT. section of the gang condenser, through a .1 MFD condenser. The ground lead from the generator must be connected to the floating ground buss under the chassis. Turn the gang condenser to complete minimum capacity. Adjust the generator to 455KC and adjust the trimmers of the 1st and 2nd I.F. transformers until a maximum reading is noted on the output meter.

SECOND STEP: With the leads from the generator still connected in the same manner, adjust the Signal Generator to 1720 KC. The OSC. trimmer is located on the front of the chassis. Adjust this trimmer until the 1720 KC signal is tuned in.

THIRD STEP: Remove the hot lead of the generator from the ANT section of the gang condenser. Connect this lead to the primary of the loop antenna through a 200 MMFD condenser. Adjust the Signal Generator to 1400 KC. Rotate the tuning control until this signal is tuned in. The ANT trimmer is located on the top of the ANT. section of the gang condenser. Adjust this trimmer until a maximum reading is noted on the output meter.

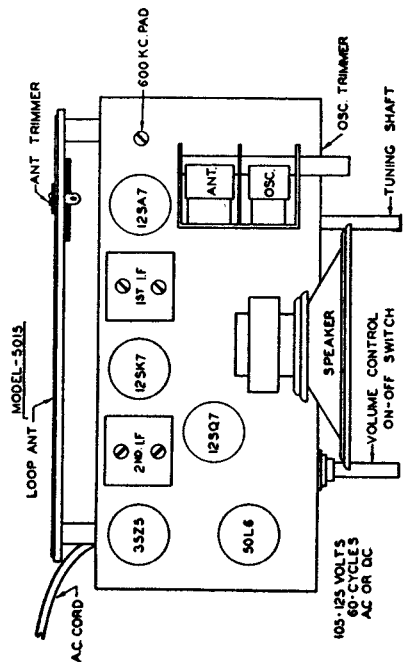

TRAV-LER MODEL 5044

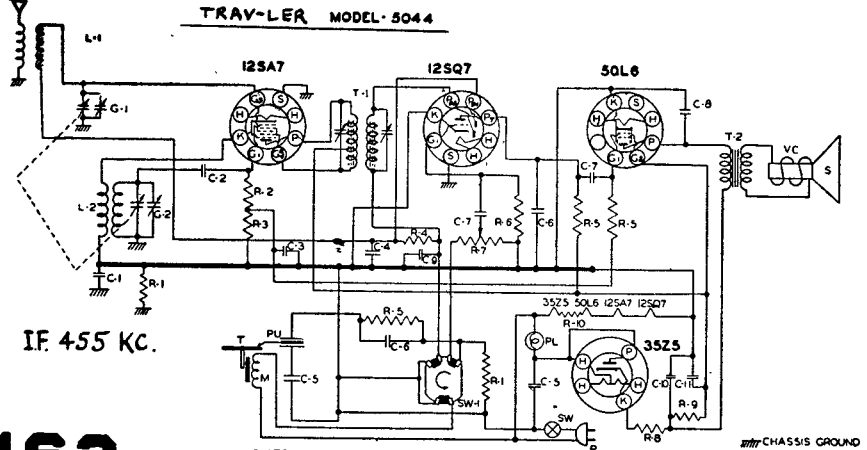

PART NO.	DESCRIPTION
IR-20	R-1 220M Ω RESISTOR 1/2W 20%
IR-8	R-2 22M Ω RESISTOR 1/2W 20%
IR-9	R-3 47M Ω RESISTOR 1/2W 20%
IR-23	R-4 3 MEG. RESISTOR 1/2W 20%
IR-11	R-5 470M Ω RESISTOR 1/2W 20%
IR-3	R-6 10 MEG. RESISTOR 1/2W 20%
VC-4	R-7 1 MEG. VOL. CONTROL
IR-17	R-8 33 Ω RESISTOR 1/2 W 20%
IR-25	R-9 2200 Ω RESISTOR 1 W 10%
IR-41	R-10 47 Ω RESISTOR 1 W 10%
PC-8	C-1 1MFD CONDENSER 400V.
PC-4	C-2 500MMFD. MICA
PC-2	C-3 1MFD CONDENSER 200V.
PC-5	C-4 .05MFD CONDENSER 200V.
MC-6	C-5 .05MFD CONDENSER 400V.
MC-6	C-6 500MMFD. MICA
PC-10	C-7 0.05MFD CONDENSER 400V.
PC-7	C-8 .01MFD CONDENSER 400V.
MC-2	C-9 100MMFD. MICA
MC-2	C-10 40MFD ELECTROLYTIC
EC-12	C-11 20MFD. 150V. ELECTROLYTIC
SW-1	SW SWITCH ON VOLUME CONTROL
LI-8	SW-1 RADIO PHONO SWITCH
T-1	I.F. TRANSFORMER
T-2	OUTPUT TRANSFORMER
V. C.	VOICE COIL
SPK-10	S 4" P.M. SPEAKER
L-1	L-1 LOOP ANTENNA
LO-14	L-2 OSC. COIL
M-2	M-2 110V 60 CYCLES MOTOR
PL-5	PL TONE ARM WITH L-75 CARTRIDGE
PB-1	PB NO. 47 PILOT BULB
CO-1A	P LINE CORD
T-1	T 8" TURN TABLE
GC-5	G-1 GANG CONDENSER
G-2	G-2

MANUAL OF 1950 MOST-OFTEN UNITED MOTORS SERVICE

SERVICE INSTRUCTIONS - BUICK MODEL 980782

DIAGRAMS

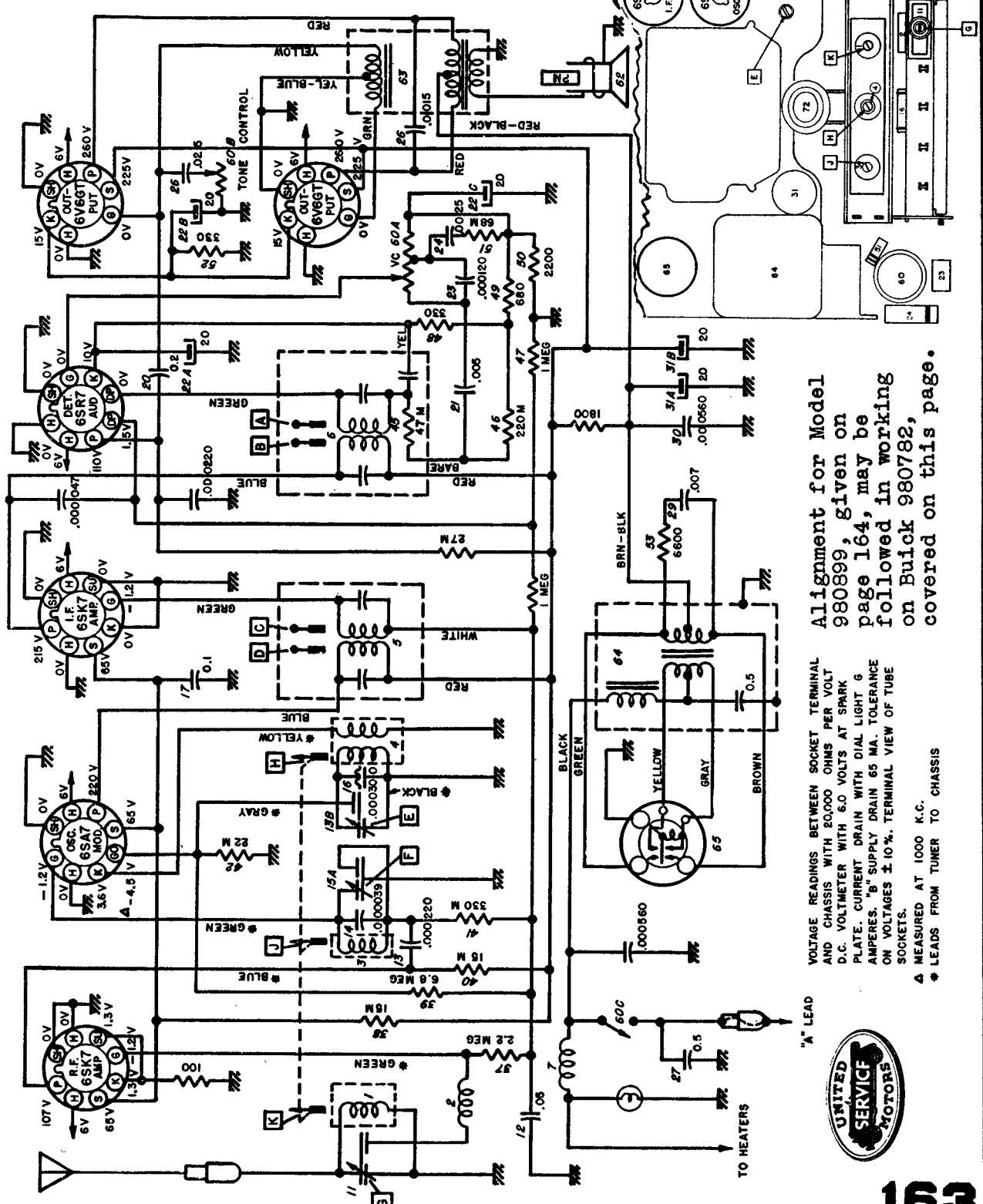

Alignment for Model 980899, given on page 164, may be followed in working on Buick 980782, covered on this page.

VOLTAGE READINGS BETWEEN SOCKET TERMINAL AND CHASSIS WITH 20,000 OHMS PER VOLT D.C. VOLTMETER WITH 6.0 VOLTS AT SPARK PLATE. CURRENT DRAIN WITH DIAL LIGHT 6 AMPERES. "B" SUPPLY DRAIN 65 MA. TOLERANCE ON VOLTAGES ± 10%. TERMINAL VIEW OF TUBE SOCKETS.

▲ MEASURED AT 1000 K.C.
* LEADS FROM TUNER TO CHASSIS

"A" LEAD



MANUAL OF 1950 MOST-OFTEN-NEEDED RADIO DIAGRAMS

UNITED MOTORS SERVICE

DIVISION OF GENERAL MOTORS CORPORATION

BUICK SELECTRONIC

MODEL 980899

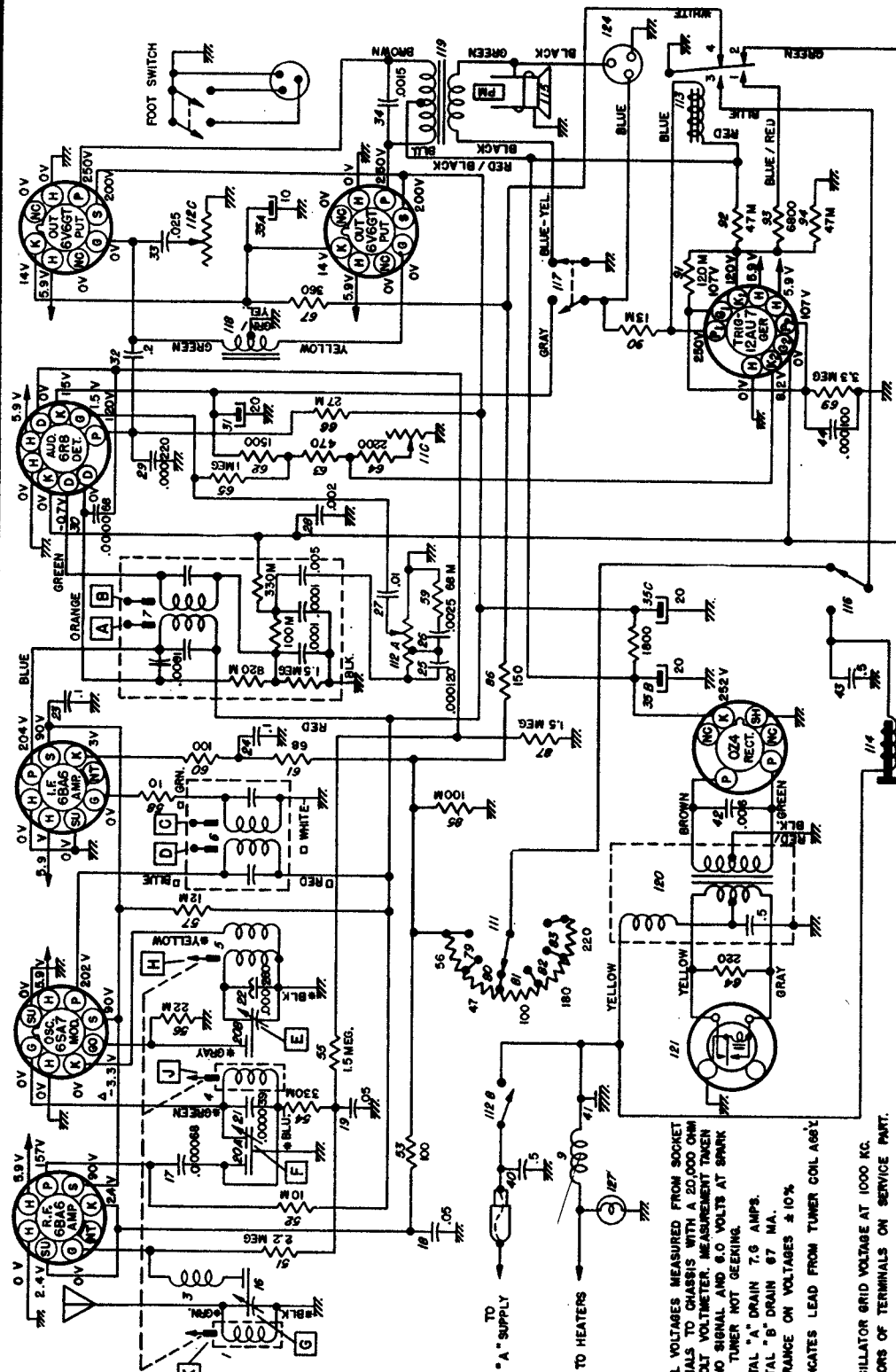

*To tune to high frequency, put a 0.070" feeler gauge (or bare #13 wire) in slot against the high frequency stop. De-press station selector bar and allow the planetary arm to run against the feeler gauge. Turn the radio off and then back on.

**Before making this adjustment, check the setting of oscillator core "H." The rear of the core should be 1 1/8" from the mounting end of the coil form. This measurement is readily made by inserting a suitable plug in the mounting end of the coil form. The core adjustment is made from the mounting end of the coil form with an insulated screwdriver. (It will be necessary to steady the core guide bar while making these adjustments. This can be done by applying a downward pressure on the guide bar at the antenna coil end.) If this adjustment is necessary, first dissolve the gypical seal on the core stud and be sure to re-seal after making the adjustment.

***"L" is the pointer adjustment screw on the end of the core guide bar—adjust so pointer reads 1000 KC.

In step 1, connect Generator thru 0.1 mfd. to pin 8 of 6SA7 in steps 2 to 5 use 62 in mfd. to Ant. Con.

ALL VOLTAGES MEASURED FROM SOCKET TERMINALS TO CHASSIS WITH A 20,000 OHM PER VOLT VOLTMETER. MEASUREMENT TAKEN WITH NO SIGNAL AND 6.0 VOLTS AT SPARK PLATE. TUNER NOT GEERING.
TOTAL "A" DRAIN 7.6 AMPS.
TOTAL "B" DRAIN 87 MA.
TOLERANCE ON VOLTAGES ± 10%
♦ - INDICATES LEAD FROM TUNER COIL A667

Δ - OSCILLATOR GRID VOLTAGE AT 1000 KC.
□ - COLORS OF TERMINALS ON SERVICE PART.

Step	Signal Generator Frequency	Tune Receiver To	Adjust in Sequence For Max. Output
1	260 KC	*High Frequency Stop	A, B, C, D
2	1615 KC	High Frequency Stop	**E, F, G
3	600 KC	Signal Generator Signal	J, K
4	1615 KC	Signal Generator Signal	F, G
5	1000 KC	Signal Generator Signal	***L

MANUAL OF 1950 MOST-OFTEN-NEEDED RADIO DIAGRAMS

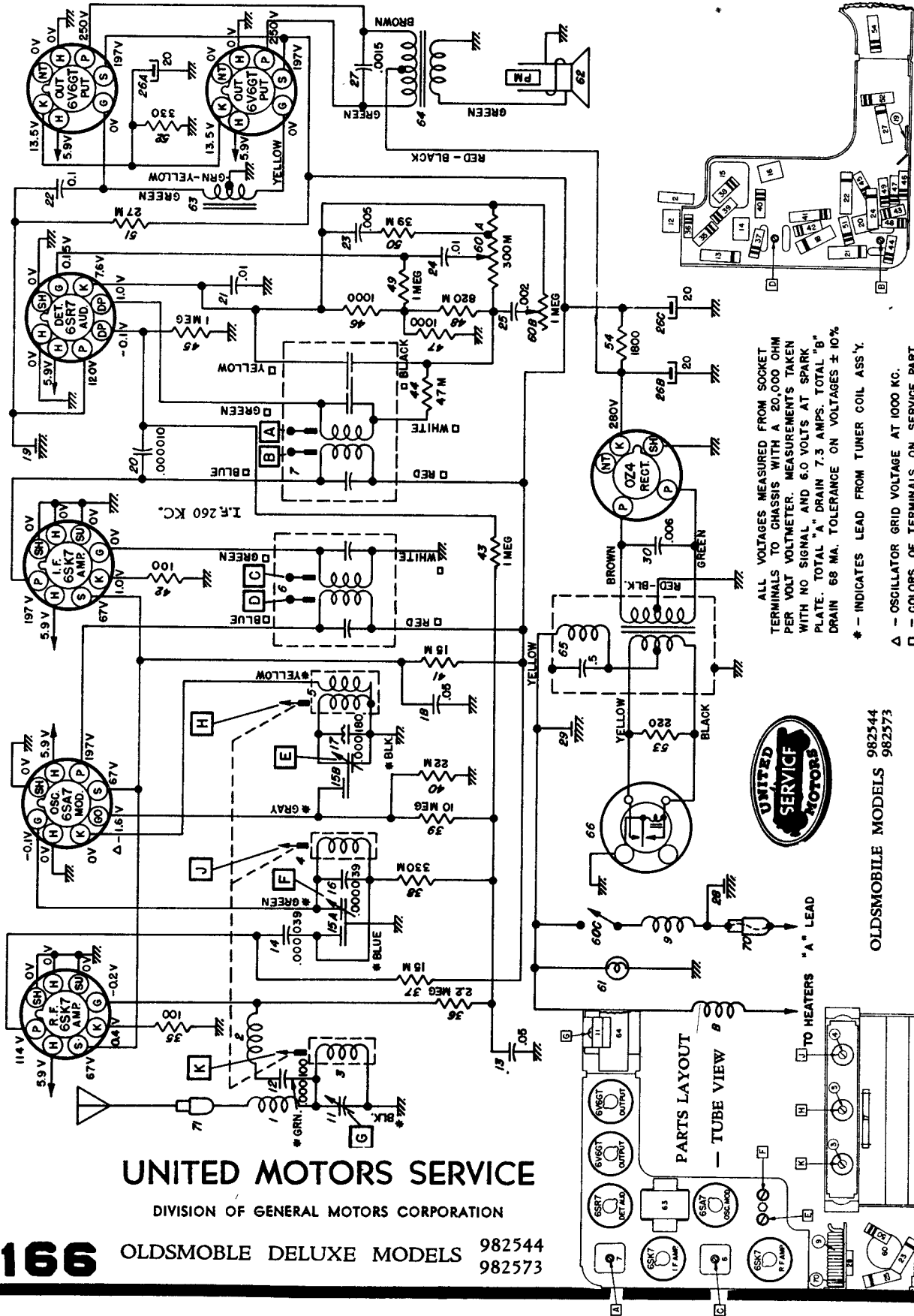

ALL VOLTAGES MEASURED FROM SOCKET TERMINALS TO CHASSIS WITH A 20,000 OHM PER VOLT VOLTMETER. MEASUREMENTS TAKEN WITH NO SIGNAL AND 6.0 VOLTS AT SPARK PLATE. TOTAL "A" DRAIN 7.3 AMPS. TOTAL "B" DRAIN 68 MA. TOLERANCE ON VOLTAGES ± 10%
 * - INDICATES LEAD FROM TUNER COIL ASS'Y.

△ - OSCILLATOR GRID VOLTAGE AT 1000 KC.
 □ - COLORS OF TERMINALS ON SERVICE PART.



OLDSMOBILE MODELS 982544 982573

NOTE: Illustration #39, 10 Megohm, 1/2 Watt Resistor was removed on all sets after serial #44678.

UNITED MOTORS SERVICE

DIVISION OF GENERAL MOTORS CORPORATION

166

OLDSMOBILE DELUXE MODELS

982544
982573

MANUAL OF 1950 MOST-OFTEN-NEEDED RADIO DIAGRAMS

Western Auto, Truetone Models D2002, D2003 (5D127 -A)

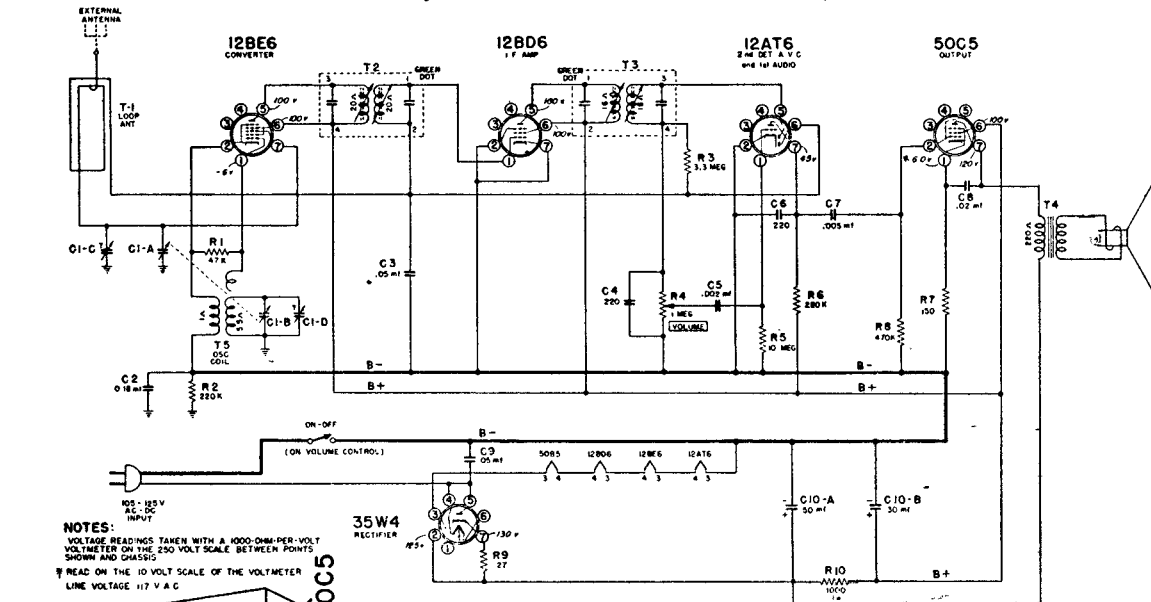

NOTES:
VOLTAGE READINGS TAKEN WITH A 1000 OHM-PER-VOLT VOLTMETER ON THE 250 VOLT SCALE BETWEEN POINTS SHOWN AND GROUND.
↑ READ ON THE 10 VOLT SCALE OF THE VOLTMETER LINE VOLTAGE 117 V A.C.

ALIGNMENT PROCEDURE

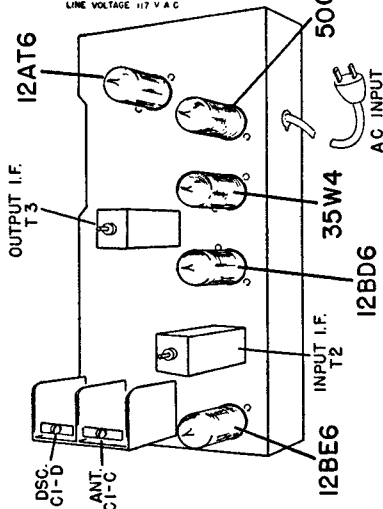

SIGNAL GENERATOR			TUNER SETTING	ADJUST FOR MAXIMUM OUTPUT
Frequency	Coupling Capacitor	Connection to Radio		
455 kc.	.1 mf.	12BE6, Pin 7	Capacitor full open (plates out of mesh)	Top and bottom Cores in output and input I.F. cans
1620 kc.	.1 mf.	12BE6, Pin 7	Capacitor full open (plates out of mesh)	Oscillator trimmer C1-D on gang
535 kc.	.1 mf.	12BE6, Pin 7	Capacitor fully closed	Check for adequate range
1400 kc.	—	Lay Generator lead near back of cabinet	Tune in 1400 kc. signal	Antenna trimmer C1-C on gang
400 cycles	.1 mf.	12AT6, Pin 1	—	—

Western Auto, Truetone Model D2004 (4B115 - Series A)

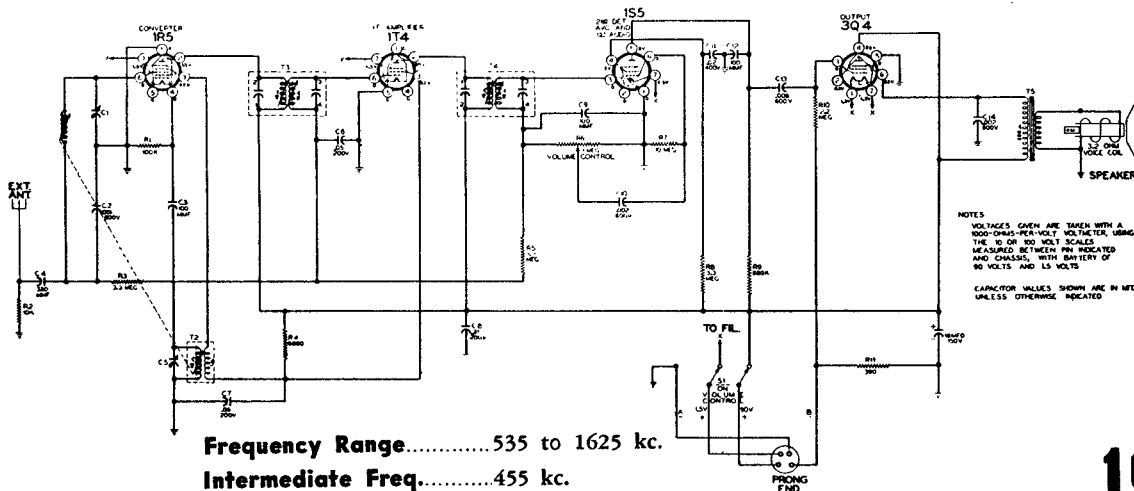

NOTES:
VOLTAGES GIVEN ARE TAKEN WITH A 1000 OHM-PER-VOLT VOLTMETER, USING THE 50 OR 250 VOLT SCALES MEASURED BETWEEN PIN INDICATED AND CHASSIS, WITH BATTERY OF 90 VOLTS AND 45 VOLTS CAPACITOR VALUES SHOWN ARE IN MFD UNLESS OTHERWISE INDICATED

Frequency Range.....535 to 1625 kc.
Intermediate Freq.....455 kc.

MANUAL OF 1950 MOST-OFTEN-NEEDED RADIO DIAGRAMS

Western Auto, Truetone Models D2002, D2003 (5D127 -A)

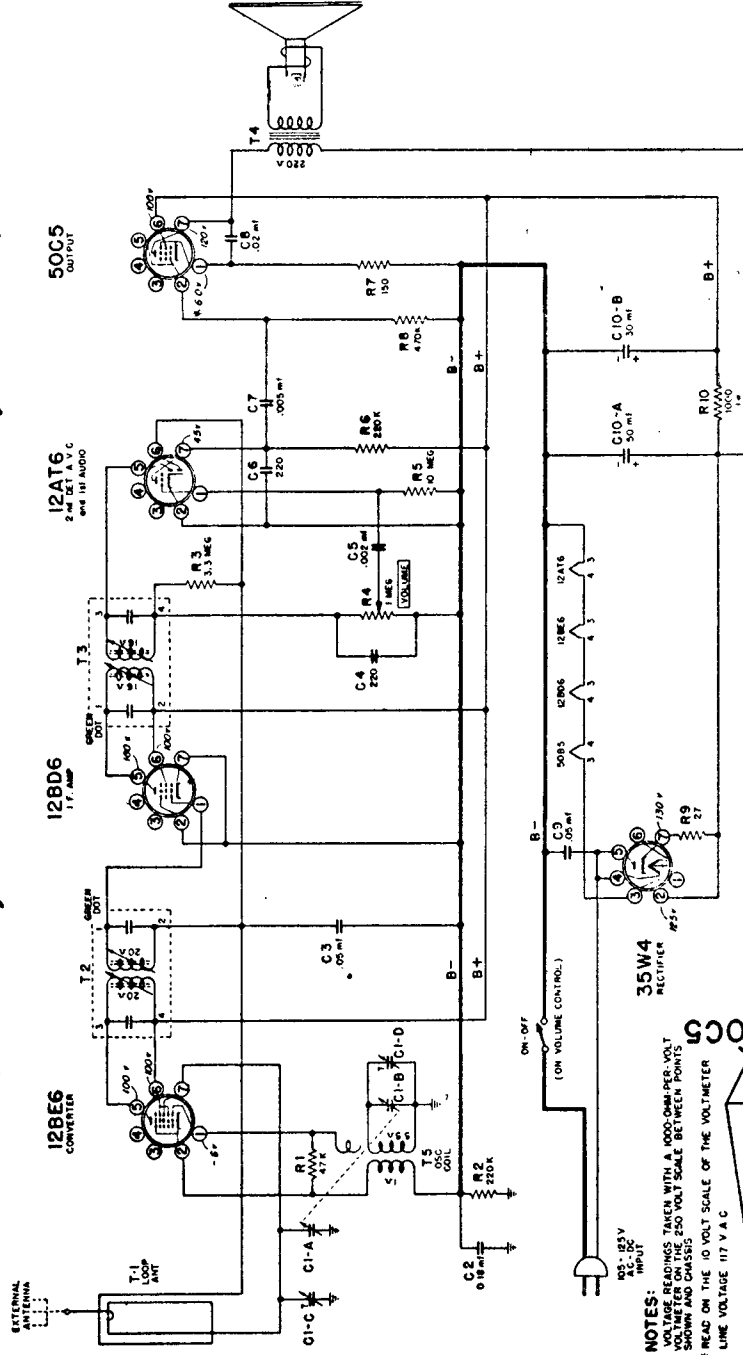

NOTES:
 VOLTAGE READINGS TAKEN WITH A 1000-OHM-PER-VOLT
 VOLTMETER ON THE 250-VOLT SCALE BETWEEN POINTS
 SHOWN AND GROUND.
 * READ ON THE 10-VOLT SCALE OF THE VOLTMETER
 LINE VOLTAGE 117 V A C

ALIGNMENT PROCEDURE

SIGNAL GENERATOR		TUNER SETTING	ADJUST FOR MAXIMUM OUTPUT
Frequency	Coupling Capacitor	Connection to Radio	
455 kc.	.1 mf.	12BE6, Pin 7	Top and bottom Cores in output and input I.F. cans
1620 kc.	.1 mf.	12BE6, Pin 7	Oscillator trimmer C1-D on gang
535 kc.	.1 mf.	12BE6, Pin 7	Check for adequate range
1400 kc.	—	Lay Generator lead near back of cabinet	Antenna trimmer C1-C on gang
400 cycles	.1 mf.	12AT6, Pin 1	—

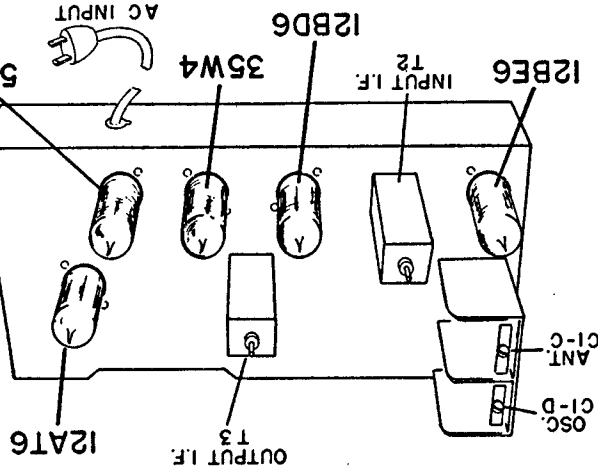

Western Auto, Truetone Model D2004 (4B115 - Series A)

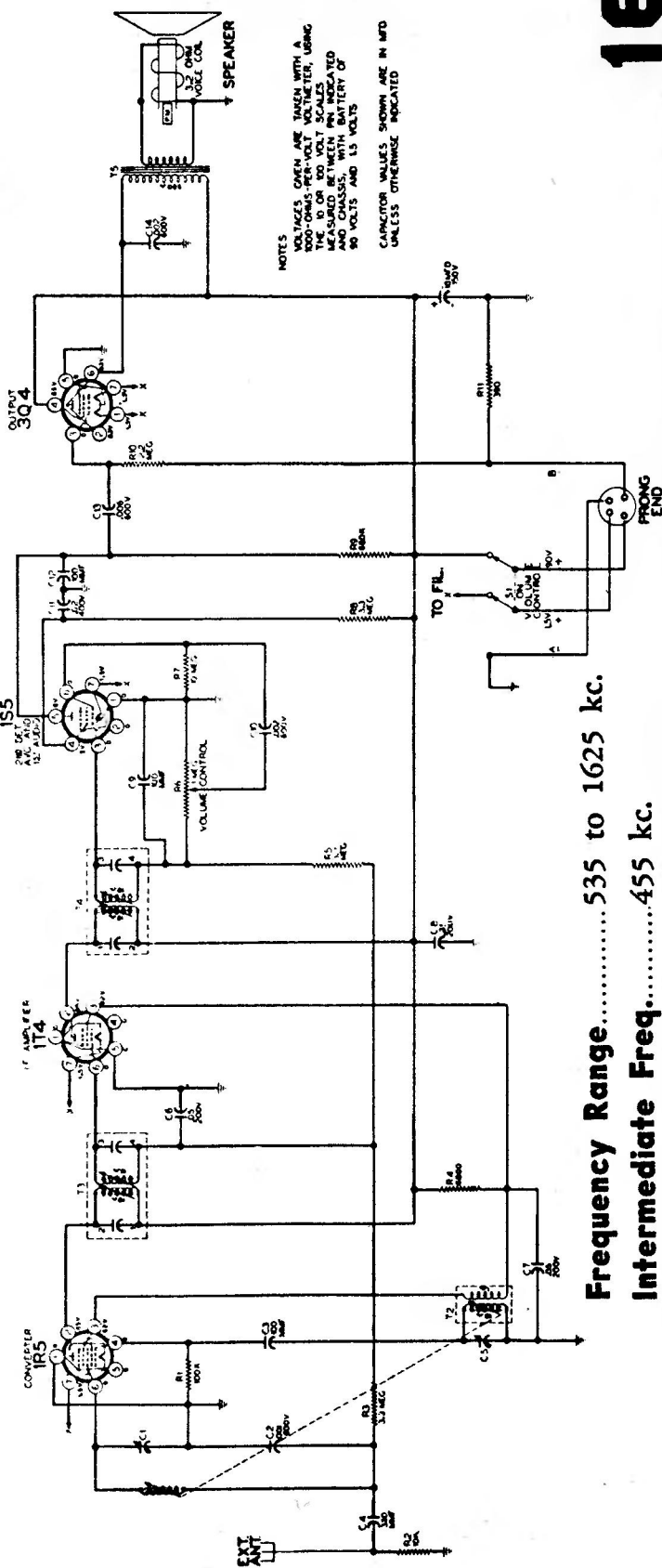

Frequency Range.....535 to 1625 kc.

Intermediate Freq.....455 kc.

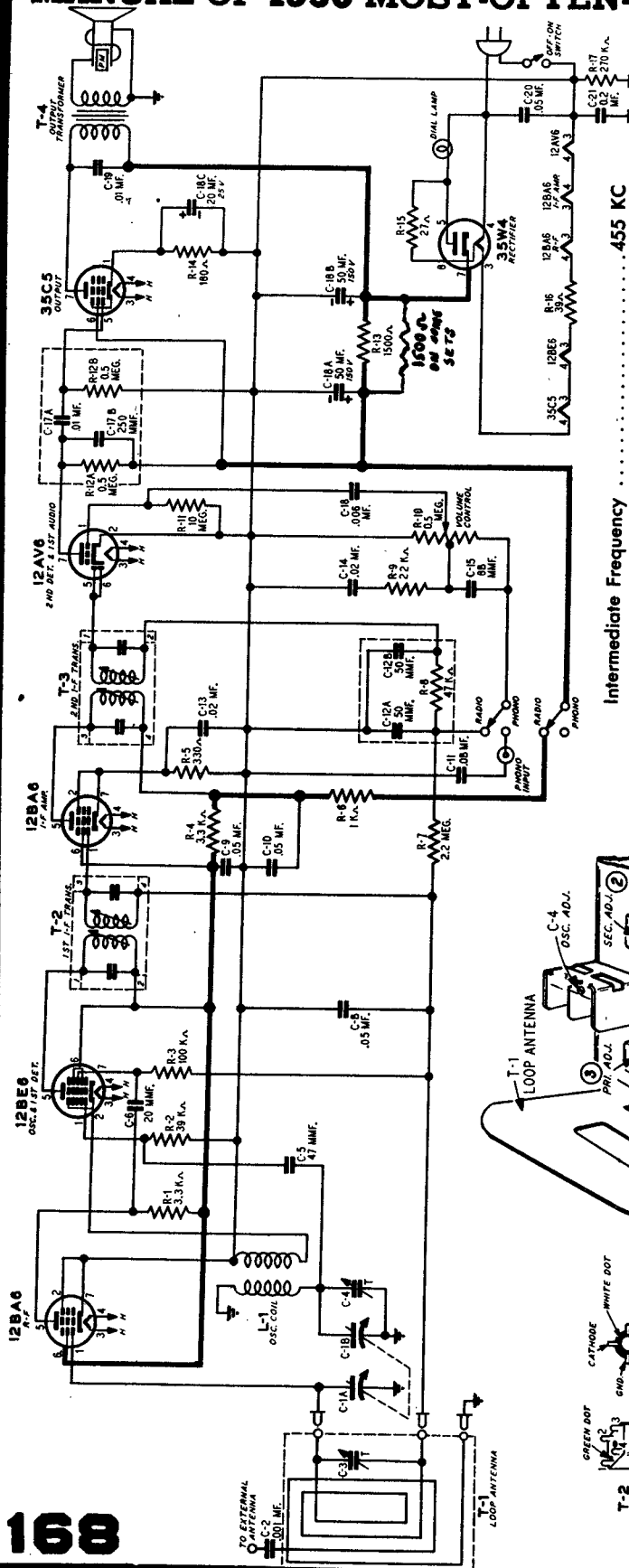

Intermediate Frequency 455 KC

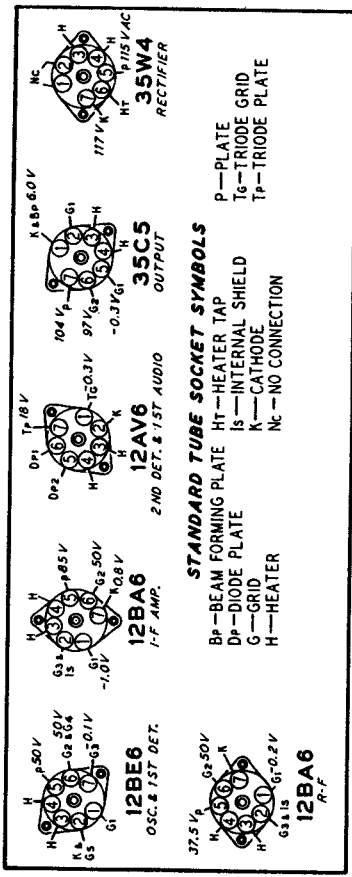

STANDARD TUBE SOCKET SYMBOLS

- Bp—BEAM FORMING PLATE
- Dp—DIODE PLATE
- G—GRID
- H—HEATER
- HT—HEATER TAP
- Is—INTERNAL SHIELD
- K—CATHODE
- Nc—NO CONNECTION
- P—PLATE
- Tg—TRIODE GRID
- Tp—TRIODE PLATE

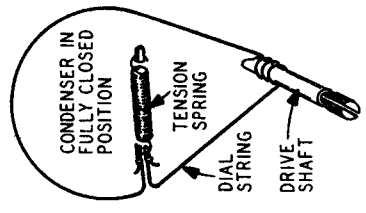
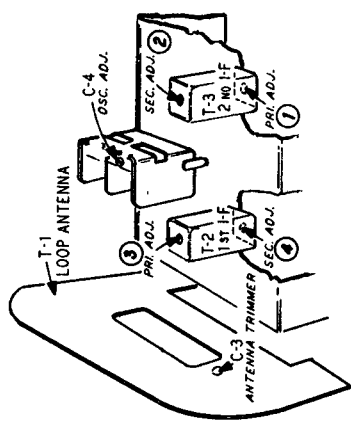

DRIVE CORD REPLACEMENT

Turn the large drive pulley to the fully closed position. Use a new 10x75 drive cord assembly or a piece of cord 16 inches long and fasten one end to the tension spring and fasten the other end of the spring to the drive pulley. Install the cord as shown in the illustration. Wind 2 1/2 turns counterclockwise around the tuning shaft with the turns progressing toward the front of the chassis. After string is installed, stretch the tension spring and fasten free end of cord to spring.

Western Auto

Tru-tone

REG. U.S. PAT. OFF.

MODEL D2017 (WALNUT)
FACTORY MODEL 25D26-006

MODEL D2018 (IVORY)
FACTORY MODEL 225D26-002

MANUAL OF 1950 MOST-OFTEN-NEEDED RADIO DIAGRAMS

Western Auto Supply Co.
Truetone Model D1946

(Factory 26A94-852)

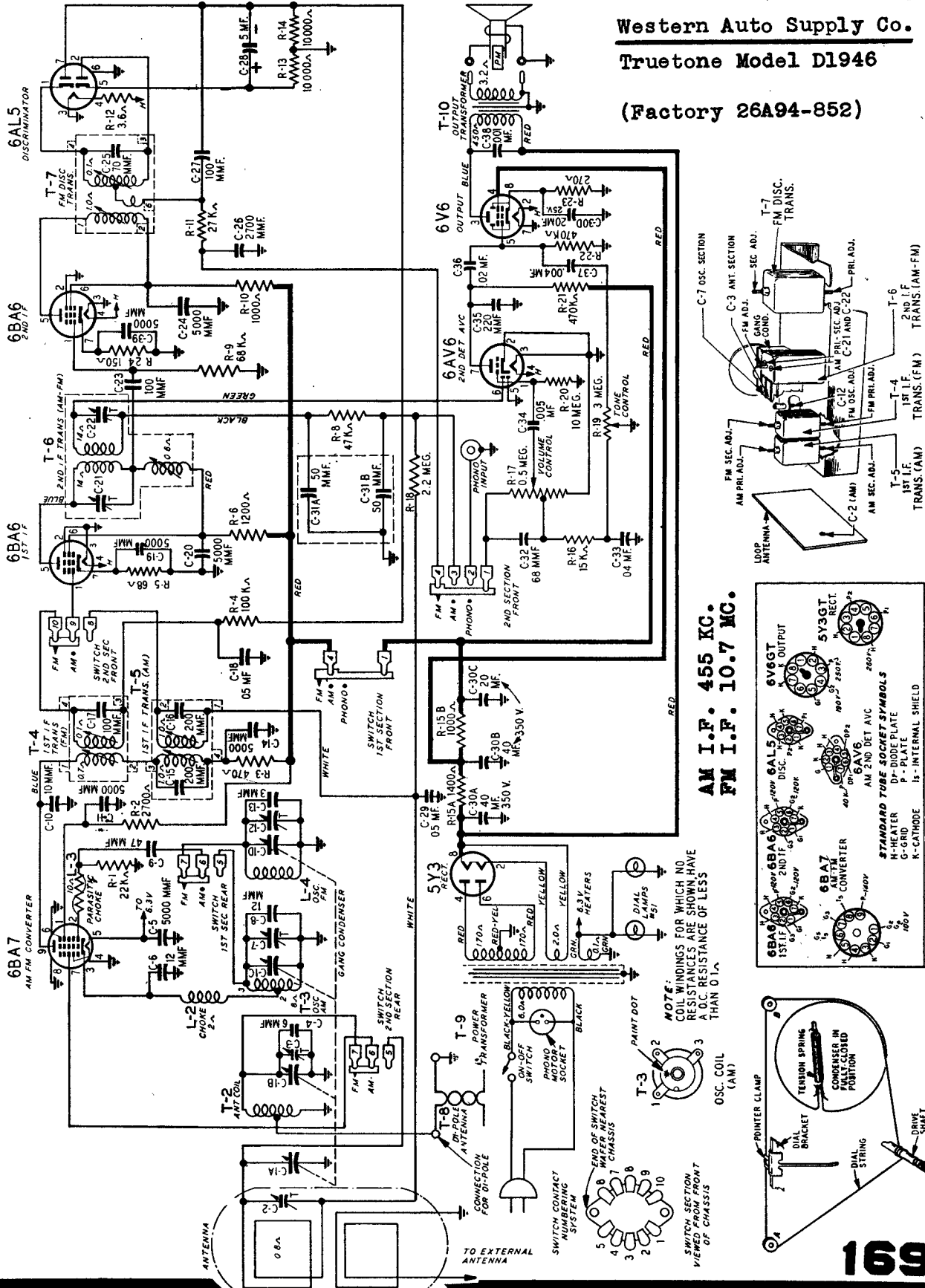

AM I.F. 455 KC.
FM I.F. 10.7 MC.

NOTE: COIL WINDINGS FOR WHICH NO RESISTANCES ARE SHOWN HAVE RESISTANCE OF LESS THAN 0.1 Ω.

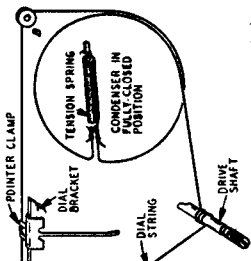
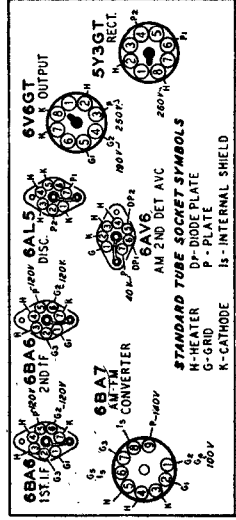

MANUAL OF 1950 MOST-OFTEN-NEEDED RADIO DIAGRAMS

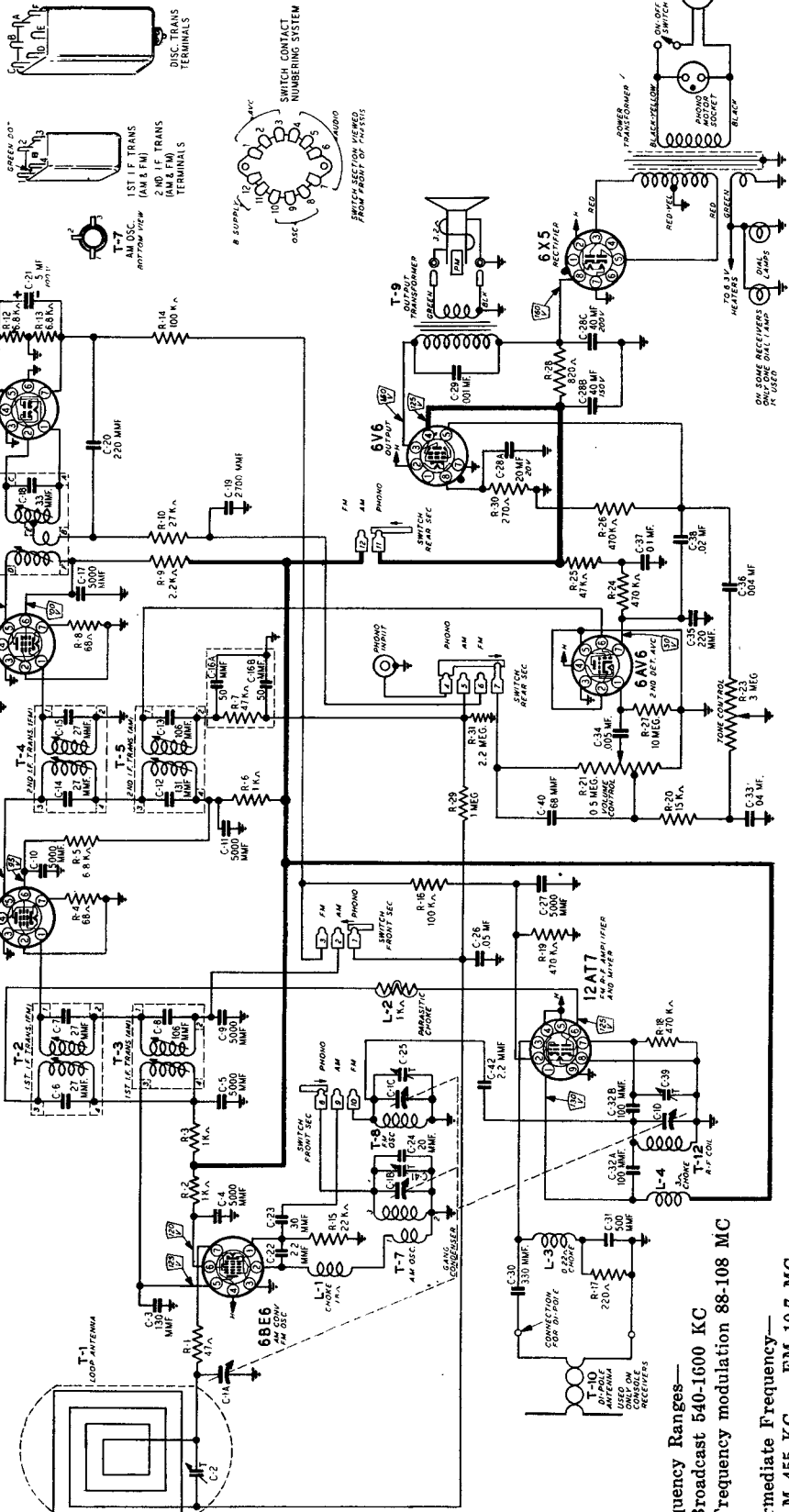

Frequency Ranges—
 Broadcast 540-1600 KC
 Frequency modulation 88-108 MC
 Intermediate Frequency—
 AM 455 KC — FM 10.7 MC

TUBE SOCKET VOLTAGES

Socket voltages are shown on the schematic diagram at the tube socket terminals. All voltages are between the socket terminal and chassis ground. Plate, screen and cathode voltages were taken with a 1000 ohm-per-volt meter with a 300 volt scale used for plate and screen voltages. Audio grid voltages were read with a vacuum tube volt-meter. Conditions of measurement are:

- Line voltage 117 Volts AC
- Signal Input None
- A Variation of $\pm 10\%$ is usually permissible.

Western Auto Supply Co.

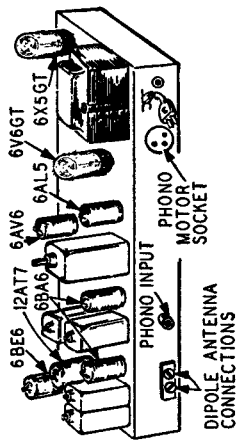

True-tone

REG. U. S. PAT. OFF.

MODEL D2027A

Factory Model 227A96-906

FM AND BROADCAST RADIO

MANUAL OF 1950 MOST-OFTEN-NEEDED RADIO DIAGRAMS

Westinghouse Electric Corporation

Model H-198, Chassis V-2137-2

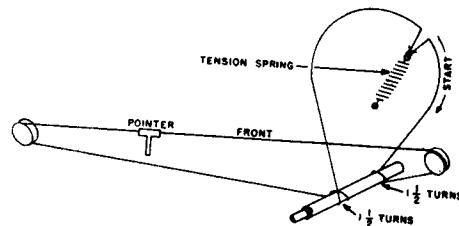
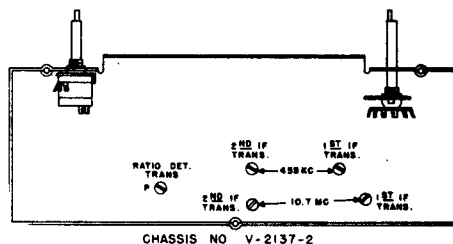
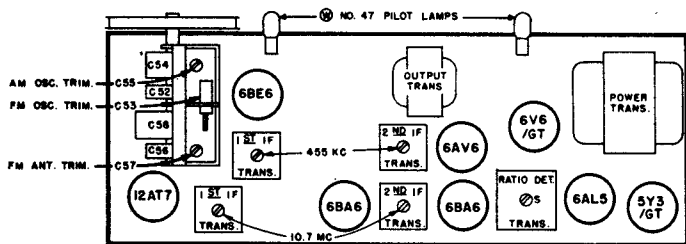

ALIGNMENT Broadcast Band

Connect an output meter across the speaker voice coil.

While making the following adjustments, keep the volume control set for maximum output, the tone control set for maximum treble, and the signal generator output attenuated to avoid A.V.C. action.

Step	Connect Signal Generator to —	Signal Generator Frequency	Radio Dial Setting	Adjust
1	Set the band switch to AM.			
2	Stator of tuning capacitor (C58) through a 0.1 mfd capacitor	455 kc.	maximum capacity	455 kc. pri. and sec. of 1st and 2nd I-F trans. for max. output
3	Radiated signal (no actual connection)	1600 kc.	1600 kc.	AM osc. trimmer (C55) for max. output
4	Radiated signal (no actual connection)	1400 kc.	tune to signal	AM ant. trimmer (C10, located on rear cover) for max. output (rock-in adjustment)

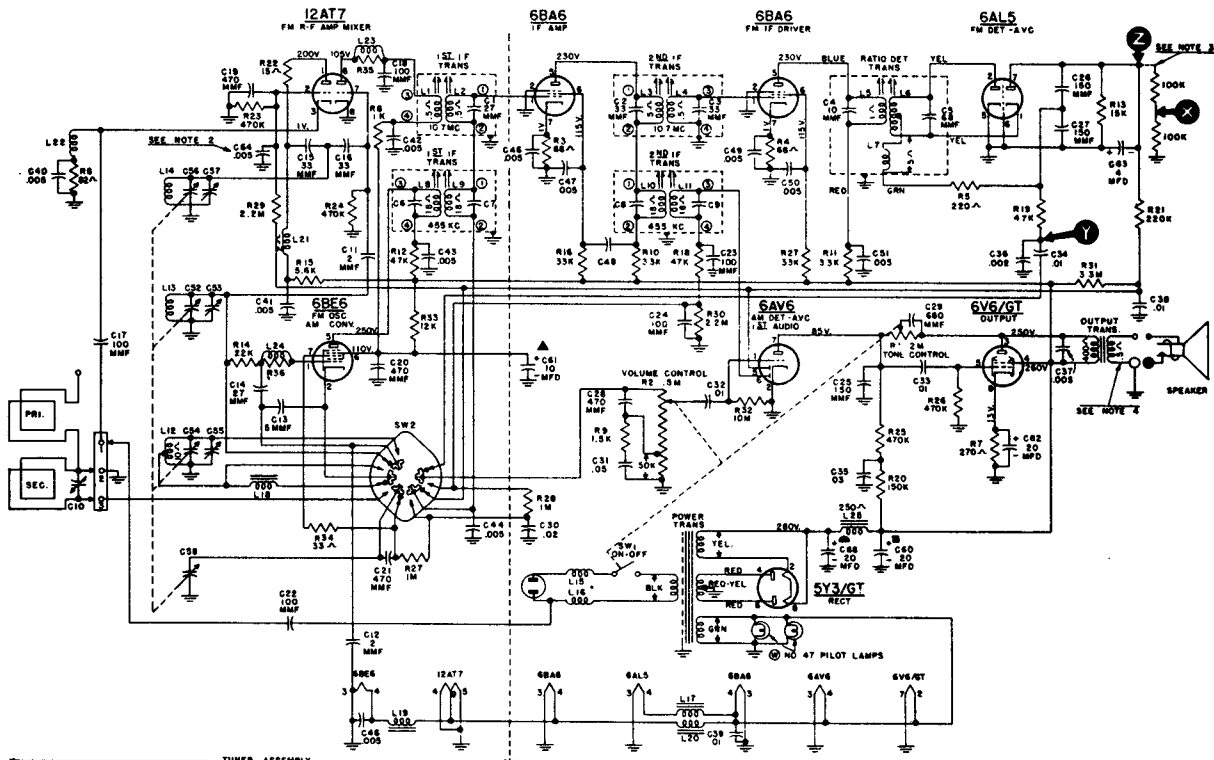

NOTE
1 SELECTOR SWITCH SW2 IS SHOWN IN EXTREME COUNTER CLOCKWISE POSITION OR FM BAND
2 FIRST POSITION, CLOCKWISE IS AM BAND
3 TO BE INSTALLED FOR ALIGNMENT ONLY

4 VOICE COIL DISCONNECTED
5 ALL VOLTAGES MEASURED FROM CHASSIS (GND) USING A 20,000 OHM/VOLT METER.
LINE VOLTAGE: 117 V.A.C. VOLTAGES SHOULD BE AS SHOWN ± 5% PER CENT.

MANUAL OF 1950 MOST

DIAGRAMS

Westinghouse Electric

Model H-199
Chassis V-2137-1

F.M. Alignment

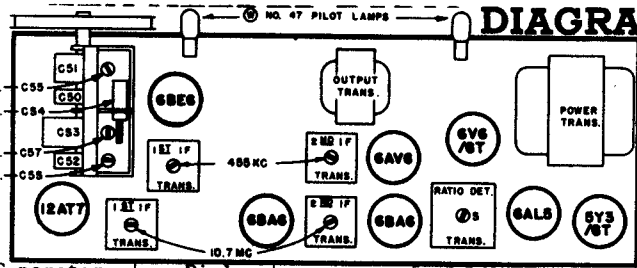

Step	Connect Signal Generator to —	Generator Frequency	Dial Setting	Adjust
1	Set the band switch to FM.			
2	Connect two 100,000 ohm resistors (the resistances must be equal within 5 percent) between pin #7 of the 6AL5 tube and ground as shown on the schematic diagram.			
3	Connect a V.T.V.M. between points "X" and "Y" (see schematic diagram).			
4	Stator of FM ant. section (C52) on tuning capacitor through a .01 mfd mica	10.7 mc.	maximum capacity	Sec. of ratio det. trans. for zero (use medium strength signal)
5	Connect the V.T.V.M. between point "Z" and ground.			
6	Same as step 4	10.7 mc.	maximum capacity	Pri. of ratio det. trans. and pri. and sec. of 10.7 mc. 1st and 2nd I-F trans. for max.
<i>NOTE: The pri. of the ratio det. trans. peaks in two places. Use the peak with the slug farthest out.</i>				
7	Reconnect the V.T.V.M. between points "X" and "Y", and increase the signal strength 2 times.			
8	Same as step 4	10.7 mc.	maximum capacity	Recheck sec. of ratio det. trans. for zero voltage
9	Reconnect the V.T.V.M. between point "Z" and ground.			
10	Same as step 4	10.7 mc.	maximum capacity	Pri. of ratio det. trans. for maximum voltage
11	Remove the two 100,000 ohm resistors that were inserted in step 2.			
12	FM ant. terminal through a 300 ohm non-inductive resistor	105 mc.	105 mc.	FM oac. trimmer (C54) for maximum output
13	Same as step 12.	105 mc.	105 mc.	FM ant. trimmer (C56) for maximum output

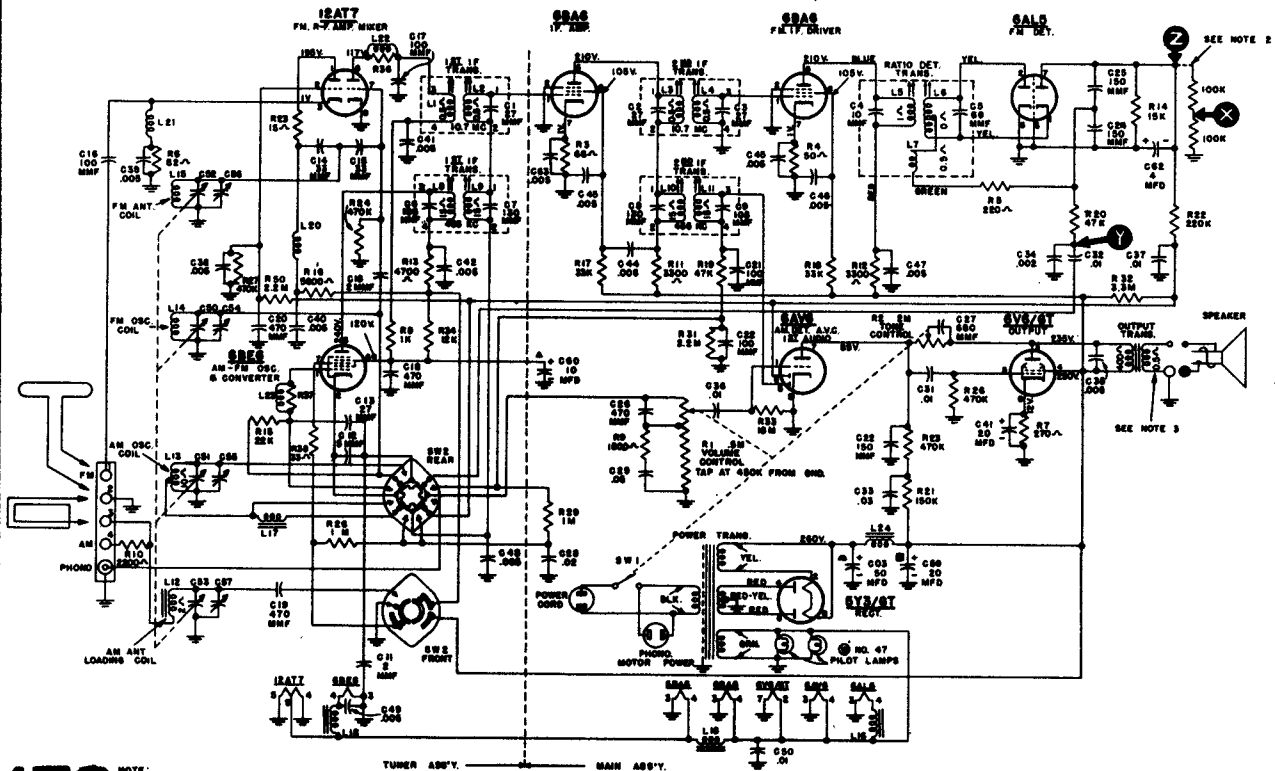

NOTE:
1. SWITCH SWS IS SHOWN IN EXTREME COUNTER CLOCKWISE POSITION SO FM BAND.
FIRST POSITION CLOCKWISE IS AM BAND.
SECOND POSITION CLOCKWISE IS PHONO.
2. TO BE INSTALLED FOR ALIGNMENT ONLY.
3. TUNER ASS'Y. MAIN ASS'Y.
4. VOICE COIL DISCONNECTED.
5. ALL VOLTAGES MEASURED FROM CHASSIS (GND.) USING A 20,000 OHM/VOLT METER.
LINE VOLTAGE 117 V.A.C. VOLTAGES SHOULD BE AS SHOWN ± 2% PER CENT.

MANUAL OF 1950 MOST-OFTEN-NEEDED RADIO DIAGRAMS

Westinghouse Electric Corporation Models H-210 and H-211

Chassis V-2144 and V-2144-1

ALIGNMENT

While making the following adjustments, keep the volume control set for maximum output and the signal generator output attenuated to avoid AVC action.

Step	Connect Signal Generator to —	Signal Generator Frequency	Radio Dial Setting	Adjust
1.	Stator of R-F tuning capacitor (C7) through a 0.1 mfd capacitor	455 kc.	maximum capacity	Pri. and sec. of 1st and 2nd I-F transformers for max. output
<p><i>NOTE: If the I-F transformers are badly mis-aligned, it may be impossible to obtain sufficient output to use the above system. In this event, it will be necessary to align each transformer separately. Start with the last I-F transformer and work forward, connecting the signal generator to the control grid of the tube preceding the transformer under alignment.</i></p>				
2.	Radiated signal (no actual connection)	1615 kc.	minimum capacity	Osc. trimmer (C10) for max. output
3.	Radiated signal (no actual connection)	1400 kc.	1400 kc.	Ant. trimmer (C8) for max. output

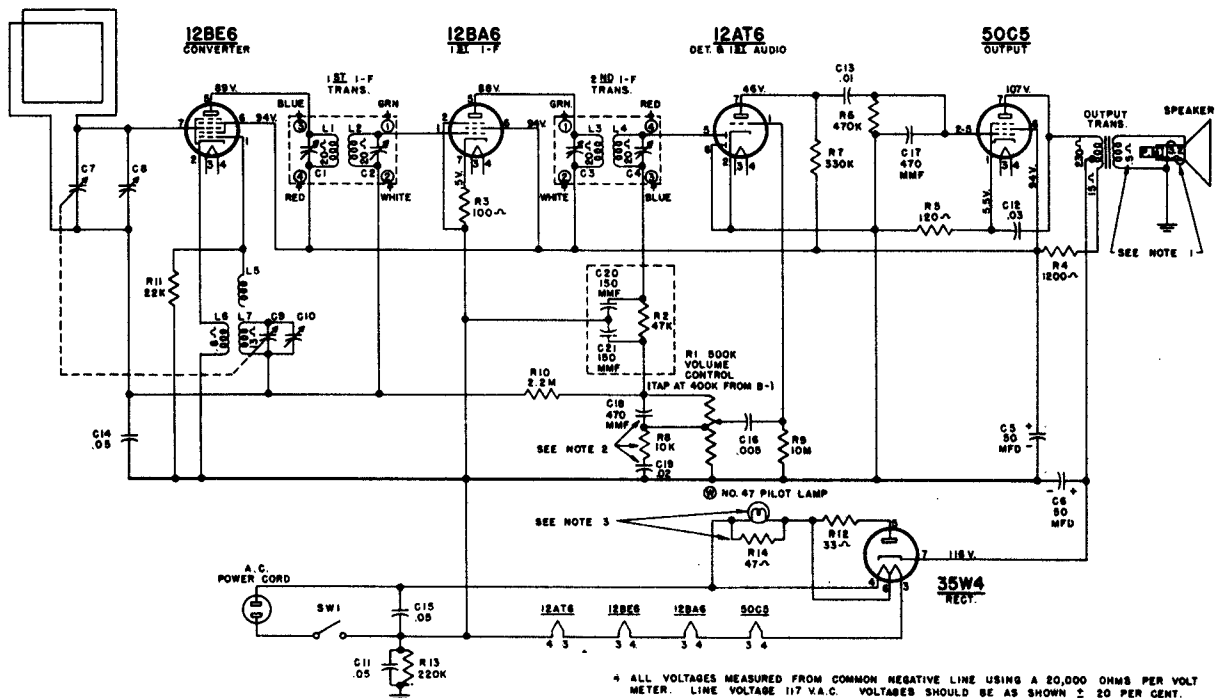
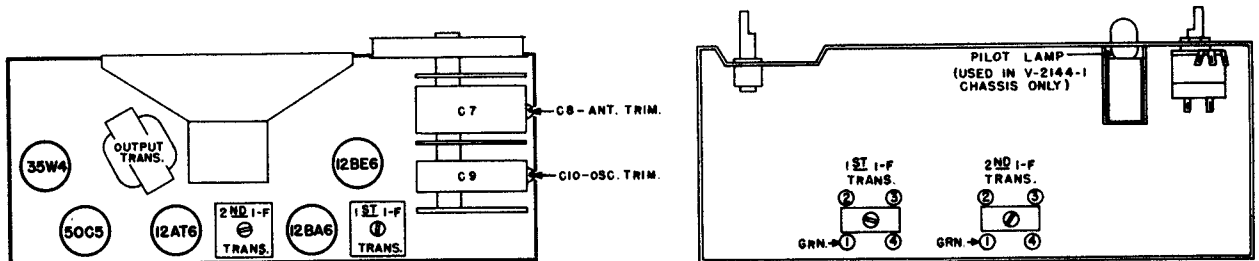

- NOTE:
1. VOICE COIL DISCONNECTED FOR RESISTANCE MEASUREMENT.
 2. C15, C18 AND R8 ARE NOT USED IN V-2144 CHASSIS (H-210).
 3. THE PILOT LAMP IS USED IN THE V-2144-1 CHASSIS (H-211) ONLY. R14 IS USED IN THE V-2144 CHASSIS (H-210) IN PLACE OF THE PILOT LAMP.

4 ALL VOLTAGES MEASURED FROM COMMON NEGATIVE LINE USING A 20,000 OHMS PER VOLT METER. LINE VOLTAGE 117 V.A.C. VOLTAGES SHOULD BE AS SHOWN \pm 20 PER CENT.

MANUAL OF 1950 MOST-OFTEN-NEEDED RADIO

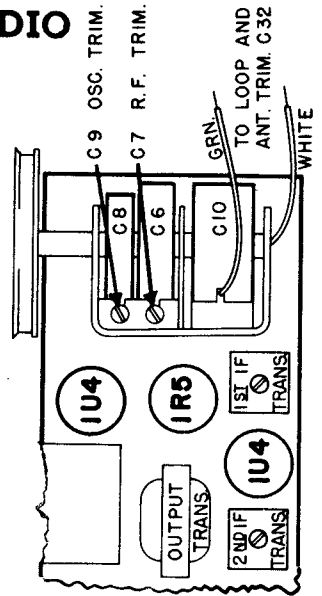
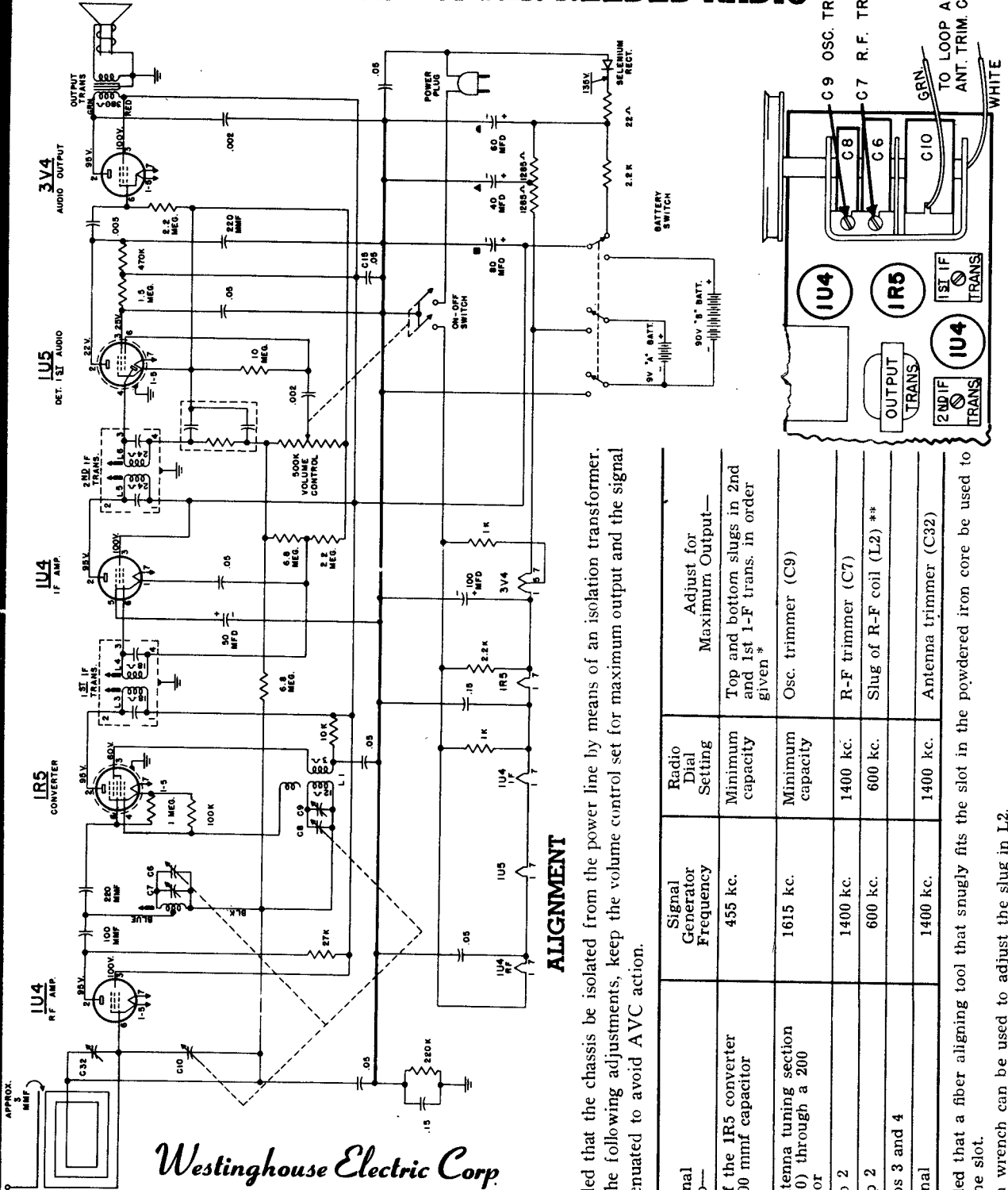

ALIGNMENT

It is recommended that the chassis be isolated from the power line by means of an isolation transformer. While making the following adjustments, keep the volume control set for maximum output and the signal generator output attenuated to avoid AVC action.

Step	Connect Signal Generator to—	Signal Generator Frequency	Radio Dial Setting	Adjust for Maximum Output—
1	Pin No. 6 of the IR5 converter through a 200 mfd capacitor	455 kc.	Minimum capacity	Top and bottom slugs in 2nd and 1st I-F trans. in order given *
2	Stator of antenna tuning section of gang (C10) through a 200 mfd capacitor	1615 kc.	Minimum capacity	Osc. trimmer (C9)
3	Same as step 2	1400 kc.	1400 kc.	R-F trimmer (C7)
4	Same as step 2	600 kc.	600 kc.	Slug of R-F coil (L2) **
5	Recheck steps 3 and 4			
6	Radiated signal	1400 kc.	1400 kc.	Antenna trimmer (C32)

* It is recommended that a fiber aligning tool that snugly fits the slot in the powdered iron core be used to prevent chipping of the slot.

** A 10/32" Allen wrench can be used to adjust the slug in L2.

Westinghouse Electric Corp.

MODEL H-302P5 CHASSIS V-2151-1

NOTES:
1. BATTERY SWITCH IS OPERATED BY PLUGGING POWER PLUG INTO SOCKET IN CHASSIS.
2. ALL VOLTAGES MEASURED FROM COMMON NEGATIVE USING A 20,000 OHM/VOLT METER.
LINE VOLTAGE SET AT 117 V A C VOLTAGES SHOULD BE AS SHOWN ± 20 PER CENT

MANUAL OF 1950 MOST-OFTEN-NEEDED RADIO DIAGRAMS

Westinghouse Electric H-300T5 AND H-301T5

CHASSIS NO. V-2148

ALIGNMENT

It is recommended that the chassis be isolated from the power line by means of an isolation transformer.

Make certain that the dial pointer is correctly positioned with respect to the dial scale.

While making the following adjustments, keep the volume control set for maximum output and the signal generator output attenuated to avoid AVC action.

Step	Connect Signal Generator to —	Signal Generator Frequency	Radio Dial	Adjust for Maximum Output —
1.	Stator of R-F tuning capacitor (C13) through a 200 mmf capacitor	455 kc.	minimum capacity	Top and bottom slugs in 2nd and 1st I-F trans. in order given *
2.	Same as step 1	1615 kc.	minimum capacity	Osc. trimmer (C16)
3.	Radiated Signal	1400 kc.	1400 kc.	R-F trimmer (C15)

* It is recommended that a fiber aligning tool that snugly fits the slot in the powdered iron core be used to prevent chipping of the slot.

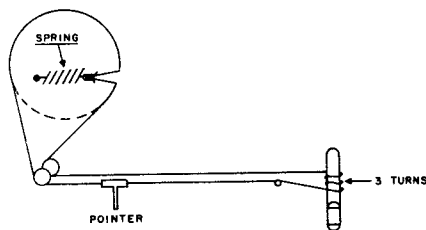

DIAL DRIVE

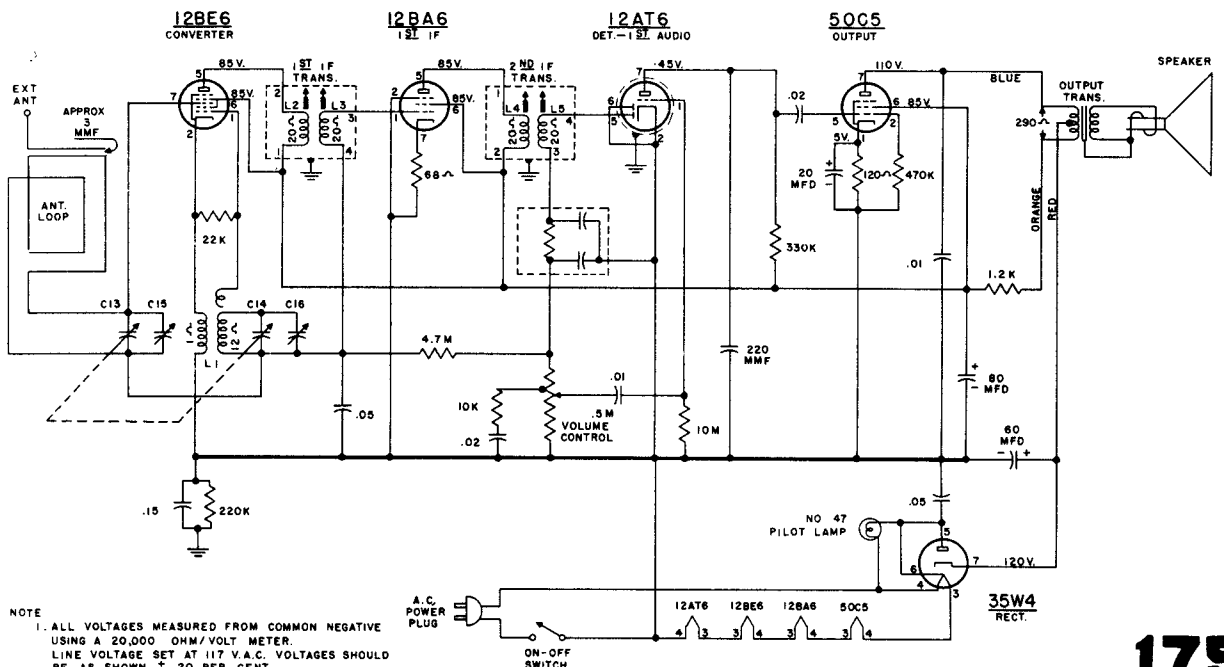
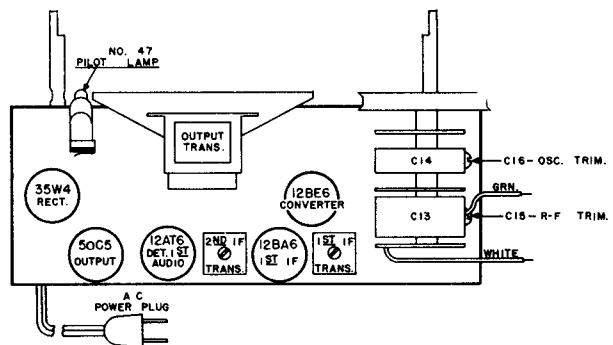

NOTE
1. ALL VOLTAGES MEASURED FROM COMMON NEGATIVE USING A 20,000 OHM/VOLT METER.
LINE VOLTAGE SET AT 117 V.A.C. VOLTAGES SHOULD BE AS SHOWN \pm 20 PER CENT.

MANUAL OF 1950 MOST-OFTEN-NEEDED RADIO DIAGRAMS

Westinghouse Electric Corporation

Models H-303P4 and H-304P4
Chassis V-2153

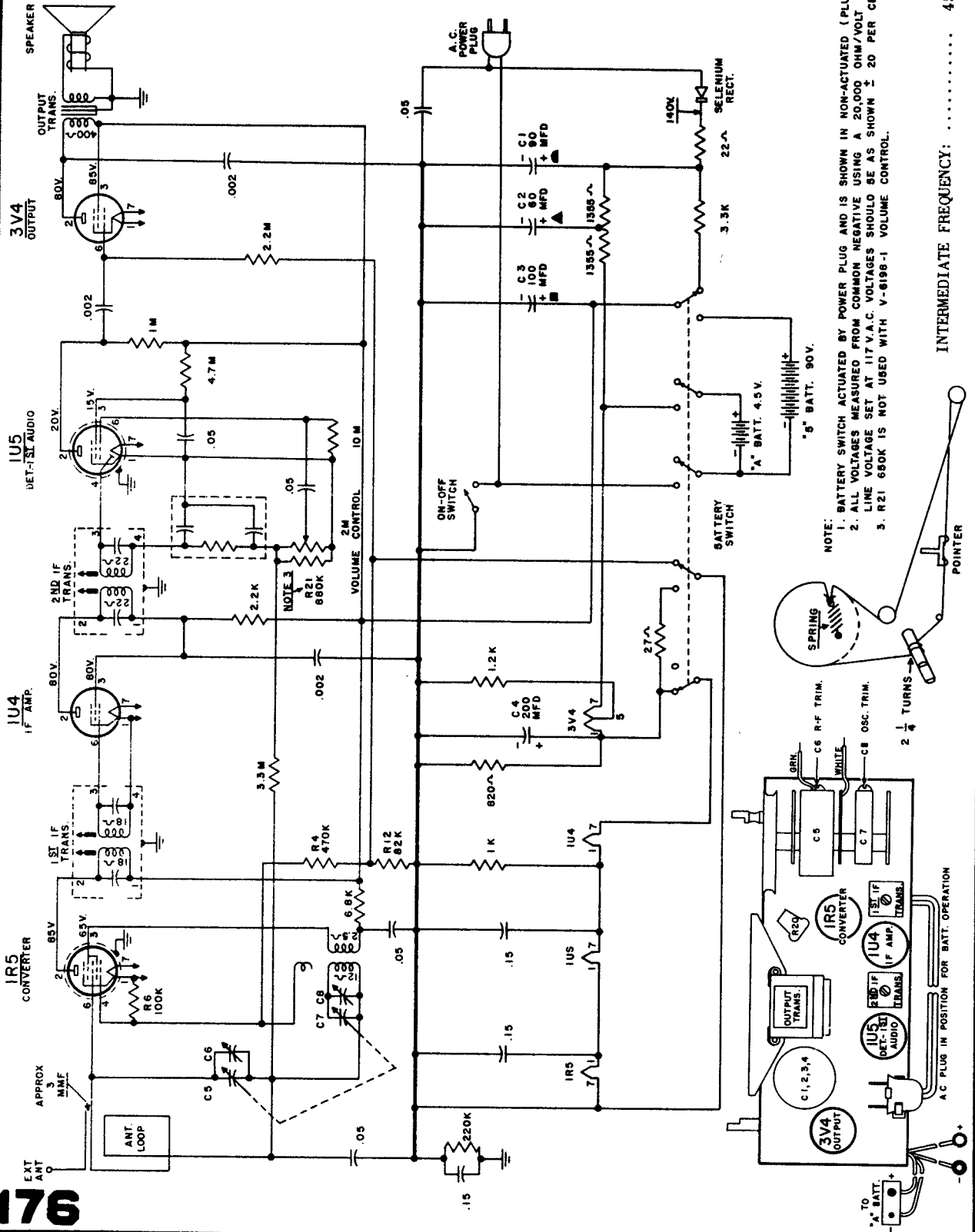

- NOTE:
1. BATTERY SWITCH ACTUATED BY POWER PLUG AND IS SHOWN IN NON-ACTUATED (PLUG OUT)
 2. ALL VOLTAGES MEASURED FROM COMMON NEGATIVE USING A 20,000 OHM/VOLT METER. LINE VOLTAGE SET AT 117 V.A.C. VOLTAGES SHOULD BE AS SHOWN \pm 20 PER CENT.
 3. R21 680K IS NOT USED WITH V-6196-1 VOLUME CONTROL.

INTERMEDIATE FREQUENCY: 455 kc.

MANUAL OF 1950 MOST-OFTEN-NEEDED RADIO DIAGRAMS

Westinghouse Electric Corporation

MODELS H-305C8 AND H-306C8

(MAHOGANY)

(BLONDE)

Chassis V-2137-4

Alignment on page 178.

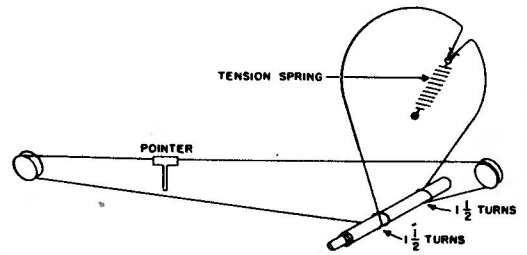

DIAL DRIVE

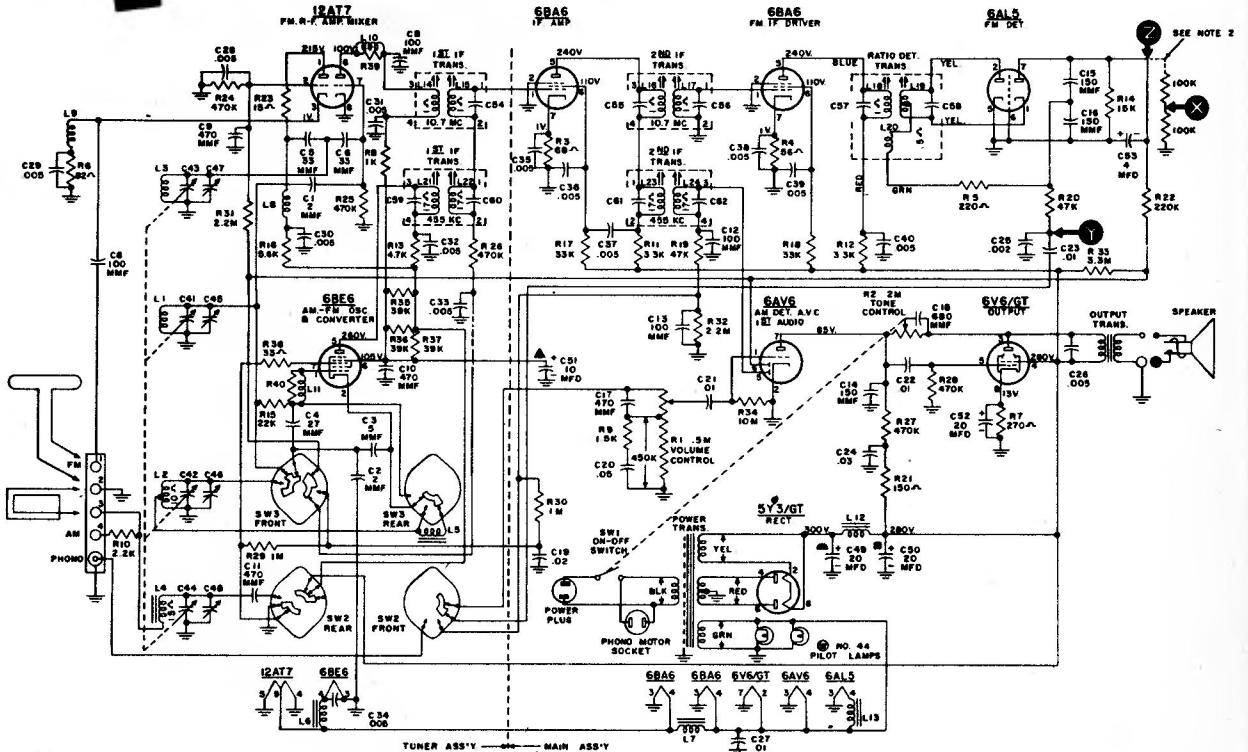

NOTE 1 SELECTOR SWITCH SW2 AND SW3 ARE SHOWN IN EXTREME COUNTER CLOCKWISE POSITION OR FM BAND
FIRST POSITION CLOCKWISE IS AM BAND
SECOND POSITION CLOCKWISE IS PHONO

2 TO BE INSTALLED FOR ALIGNMENT ONLY.
3 ALL VOLTAGES MEASURED FROM CHASSIS (GND) USING A 20,000 OHM/VOLT METER. LINE VOLTAGE SET AT 117 V.A.C. VOLTAGES SHOULD BE AS SHOWN ± 20 PER CENT

CHASSIS NO. V-2137-4

MANUAL OF 1950 MOST-OFTEN-NEEDED RADIO DIAGRAMS

Westinghouse RADIO TELEVISION

MODELS H-305C8 AND H-306C8 (Continued)

See page 177 for schematic.

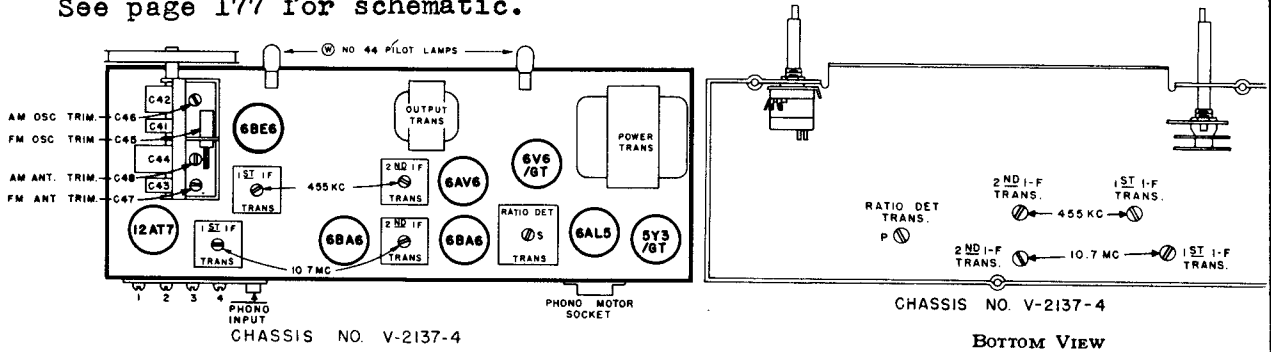

TOP VIEW

ALIGNMENT

BROADCAST BAND

Connect an output meter across the speaker voice coil.

While making the following adjustments, keep the volume control set for maximum output, the tone control set for maximum treble, and the signal generator attenuated to avoid A.V.C. action.

Step	Connect Signal Generator to—	Signal Generator Frequency	Radio Dial Setting	Adjust
1	Set the band switch to AM.			
2	Stator of tuning capacitor (C44) through a 0.1 mfd capacitor	455 kc.	maximum capacity	455 kc. pri. and sec. of 1st and 2nd I-F trans. for max. output

NOTE: If the I-F transformers are badly mis-aligned, it may be impossible to obtain sufficient output using the above system. In this event, it will be necessary to align each transformer separately. Start with the last I-F transformer and work forward, connecting the signal generator to the control grid of the tube preceding the transformer under alignment.

3	Radiated signal (no actual connection)	1600 kc.	1600 kc.	AM osc. trimmer (C46) for max. output
4	Radiated signal (no actual connection)	1400 kc.	tune to signal	AM ant. trimmer (C48) for max. output (rock-in adjustment)

FM BAND

Do not align the FM circuits until all AM adjustments have been completed.

Step	Connect Signal Generator to—	Signal Generator Frequency	Radio Dial Setting	Adjust
1	Set the band switch to FM.			
2	Connect two 100,000 ohm resistors (the resistances must be equal within 5 percent) between pin No. 7 of the 6AL5 tube and ground as shown on the schematic diagram.			
3	Connect a V. T. V. M. between points "X" and "Y" (see schematic diagram).			
4	Stator of FM ant. section (C43) on tuning capacitor through a .01 mfd mica capacitor	10.7 mc.	maximum capacity	Sec. of ratio det. trans. for zero (use medium strength signal)
5	Connect the V. T. V. M. between point "Z" and ground.			
6	Same as step 4	10.7 mc.	maximum capacity	Pri. of ratio det. trans. and pri. and sec. of 10.7 mc. 1st and 2nd I-F trans. for max.

NOTE: The pri. of the ratio det. trans. peaks in two places. Use the peak with the slug farthest out.

7	Reconnect the V. T. V. M. between points "X" and "Y", and increase the signal strength 10 times.			
8	Same as step 4	10.7 mc.	maximum capacity	Recheck sec. of ratio det. trans. for zero voltage
9	Reconnect the V. T. V. M. between point "Z" and ground.			
10	Same as step 4	10.7 mc.	maximum capacity	Pri. of ratio det. trans. for maximum voltage
11	Remove the two 100,000 ohm resistors that were inserted in step 2.			
12	FM ant. terminal through a 300 ohm non-inductive resistor	105 mc.	105 mc.	FM osc. trimmer (C45) for maximum output
13	Same as step 12	105 mc.	105 mc.	FM ant. trimmer (C47) for maximum output

MANUAL OF 1950 MOST-OFTEN-NEEDED RADIO DIAGRAMS

Westinghouse Electric Corporation

H-310T5, H-311T5, H-310T5U, AND H-311T5U

V-2161 AND V-2161U CHASSIS

ALIGNMENT

It is recommended that the chassis be isolated from the power line by means of an isolation transformer.

Make certain that the dial pointer is correctly positioned. When the gang is completely closed, the pointer should be over the small bump near the left end of the dial background.

While making the following adjustments, keep the volume control set for maximum output and the signal generator output attenuated to avoid AVC action.

Step	Connect Signal Generator to —	Signal Generator Frequency	Radio Dial	Adjust for Maximum Output—
1	Stator of R-F tuning capacitor (A) through a 0.1 mfd capacitor	455 kc.	Minimum capacity	Top and bottom slugs in 2nd and 1st I-F trans. in order given *
2	Same as step 1	1615 kc.	Minimum capacity	Osc. trimmer (D)
3	Radiated Signal	1400 kc.	1400 kc.	Ant. trimmer (B)

* It is recommended that a fiber aligning tool that snugly fits the slot in the powdered iron core be used to prevent chipping of the slot.

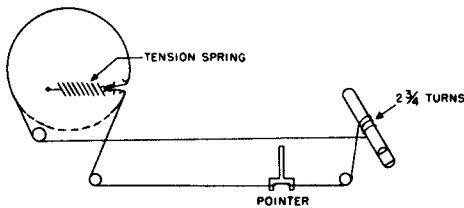

DIAL DRIVE

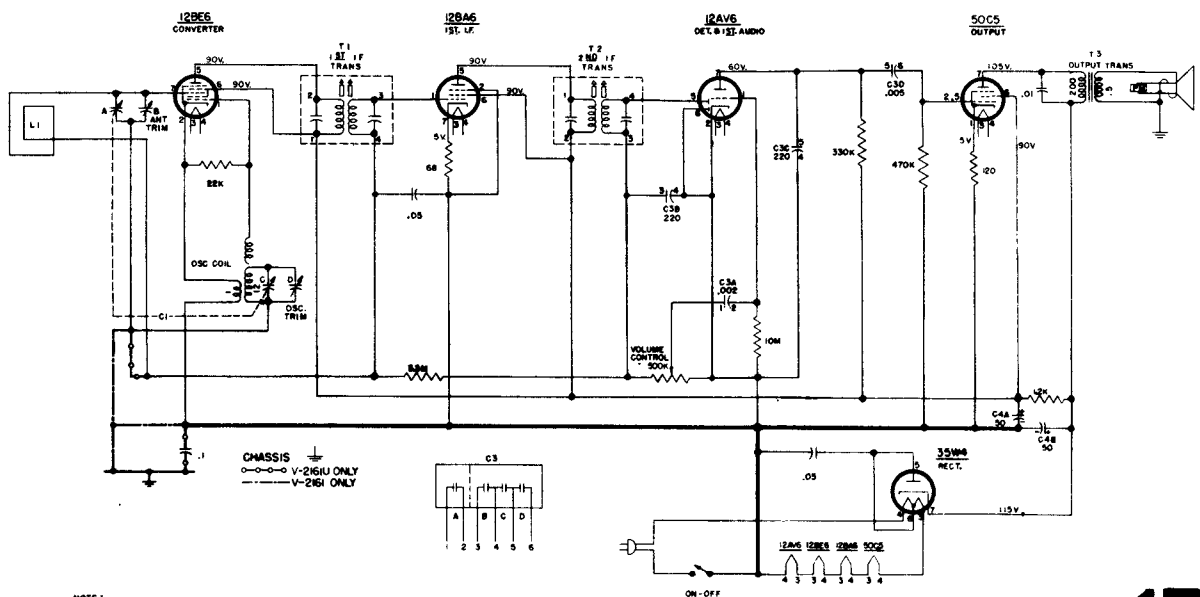
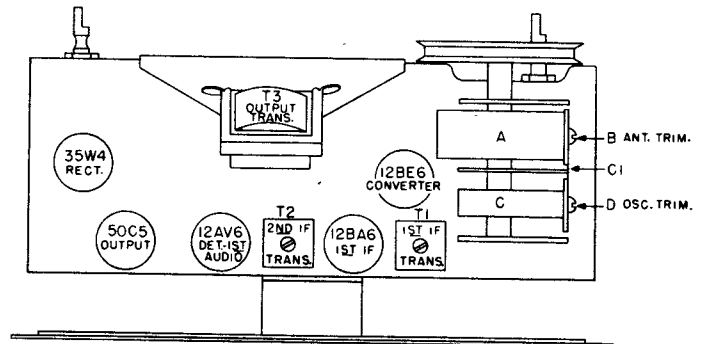

NOTE:
1. ALL VOLTAGES MEASURED FROM CHASSIS GROUND (V-2161 ONLY) OR COMMON NEGATIVE (V-2161U ONLY) USING A 20,000 OHM/VOLT METER.
LINE VOLTAGE SET AT 117 V. A. C. READINGS SHOULD BE AS SHOWN \pm 20 PER CENT.

MANUAL OF 1950 MOST-OFTEN-NEEDED RADIO DIAGRAMS

Westinghouse Electric Corporation

Models H-312P4, H-312P4U, H-313P4, and H-313P4U

Chassis V-2153-1

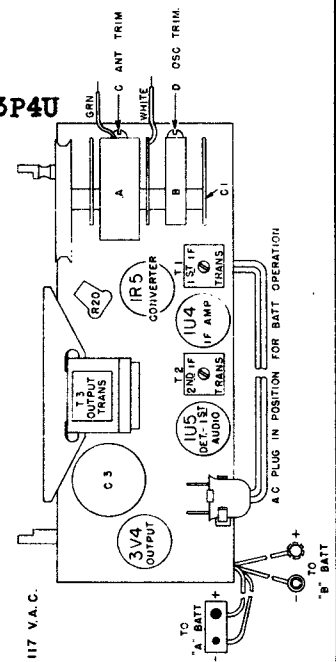
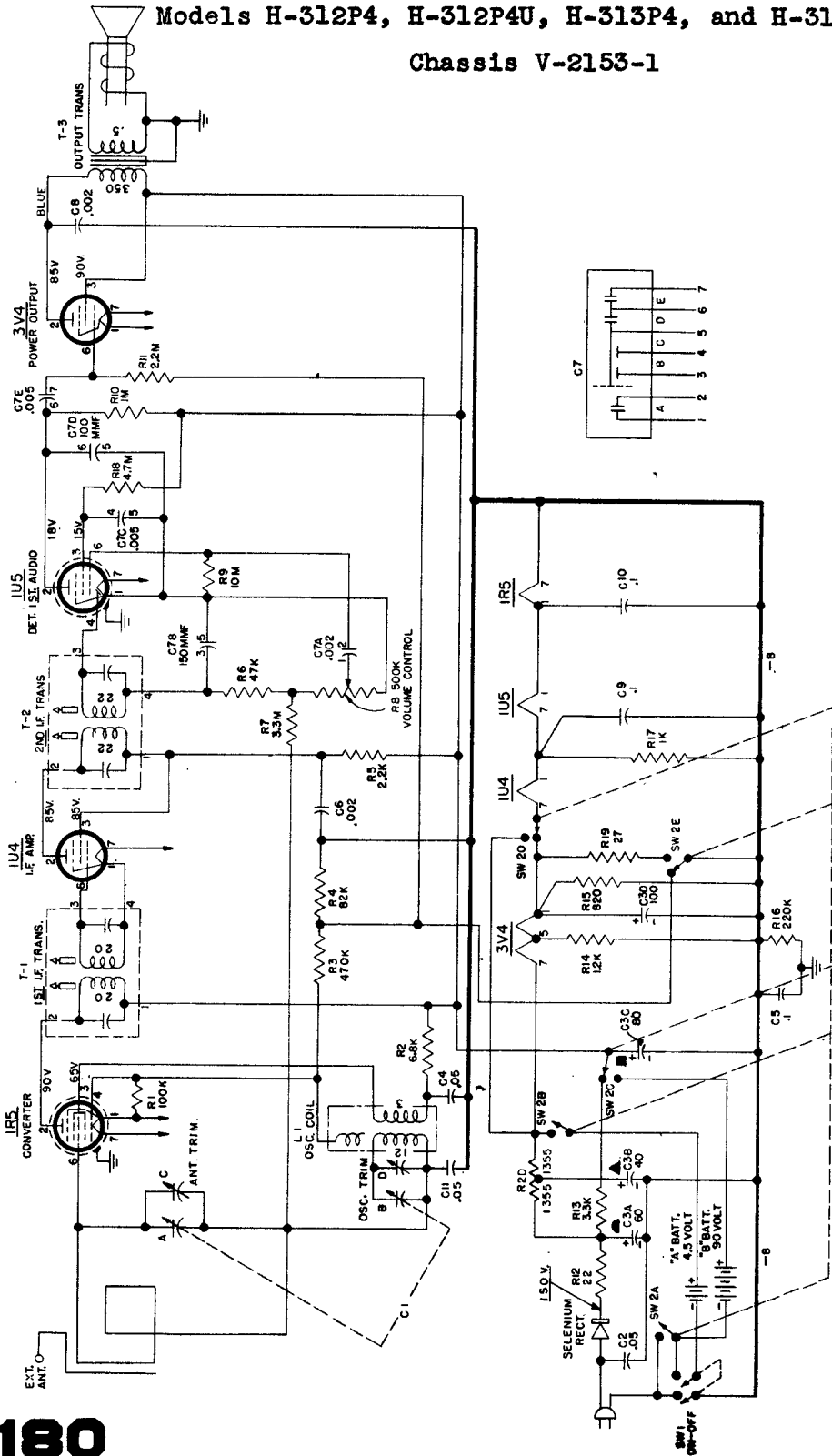

NOTE
 1 ALL VOLTAGES MEASURED FROM COMMON NEGATIVE USING A 20,000 OHM/VOLT METER. LINE VOLTAGE SET AT 117 V.A.C.
 2 VOLTAGES SHOULD BE AS SHOWN ± 20 PER CENT.
 3 ALL CAPACITOR VALUES ARE SHOWN IN MFD. UNLESS OTHERWISE SPECIFIED.
 4 ALL RESISTOR VALUES ARE SHOWN IN OHMS UNLESS OTHERWISE SPECIFIED.

I.F. 455 KC.

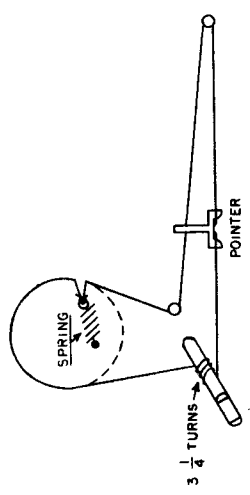

MANUAL OF 1950 MOST-OFTEN-NEEDED RADIO DIAGRAMS

MODELS G511 CHASSIS 5G01

Zenith Radio Model G511, Chassis 5G01, is similar to Model G510, Chassis 5G02, which does not use a pilot light and has a 3-terminal U1 part.

ZENITH RADIO CORP.

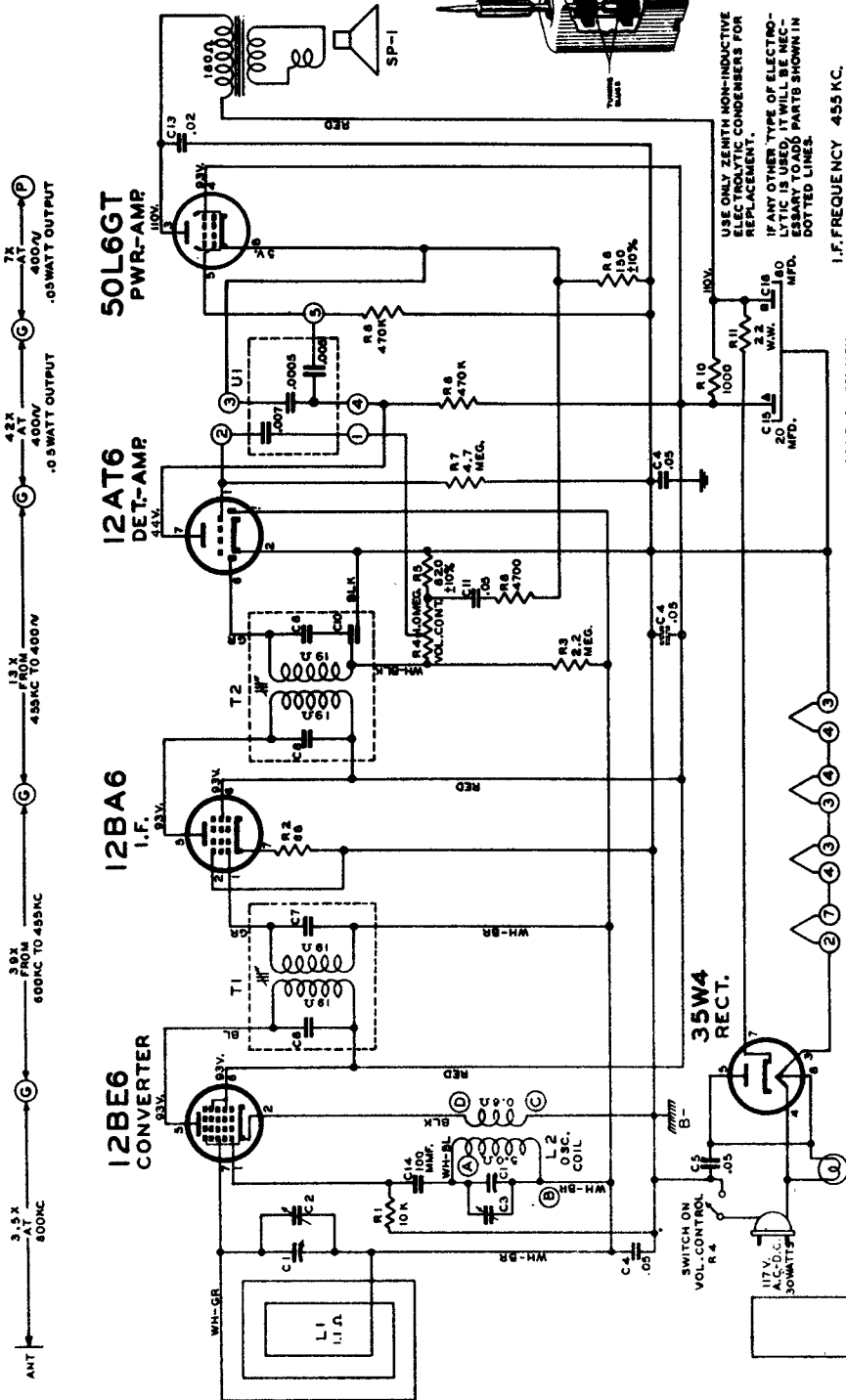
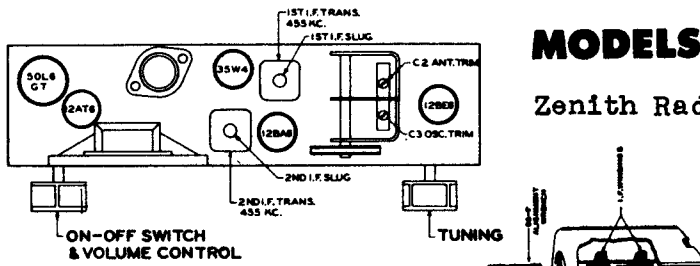

I.F. FREQUENCY 455 KC.
TUNING RANGE
535—1620 K.C.

ALL VOLTAGES MEASURED FROM COMMON RETURN TO POINTS INDICATED WITH AN ARROW. ALL VOLTAGES ARE D.C. UNLESS OTHERWISE SPECIFIED.

ALL RESISTORS 10% TOLERANCE UNLESS OTHERWISE SPECIFIED.

ALIGNMENT PROCEDURE

OPERATION	CONNECTOR TO OSCILLATOR	DUMMY ANTENNA	INPUT SIG. FREQUENCY	SET DIAL AT	TRIMMERS	PURPOSE
1	Converter Grid	.5 Mfd.	455 Kc.	600 Kc.	Adjust Primary & Secondary Slugs C-3	For I. F. Alignment
2	One Turn Loop Coupled Loosely to Wave Magnet	--	1600 Kc.	1600 Kc.	C-3	Set Oscillator to Dial Scale.
3	--	--	1400 Kc.	1400 Kc.	C-2	Align Antenna Stage

ON MULTIPLE SECTION CAPACITORS LEADS NUMBERING TO THE PART NUMBER AS SHOWN.

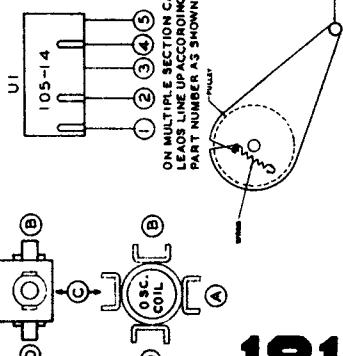

MANUAL OF 1950 MOST-OFTEN-NEEDED RADIO DIAGRAMS

Zenith Radio Model G516, Chassis 5G03

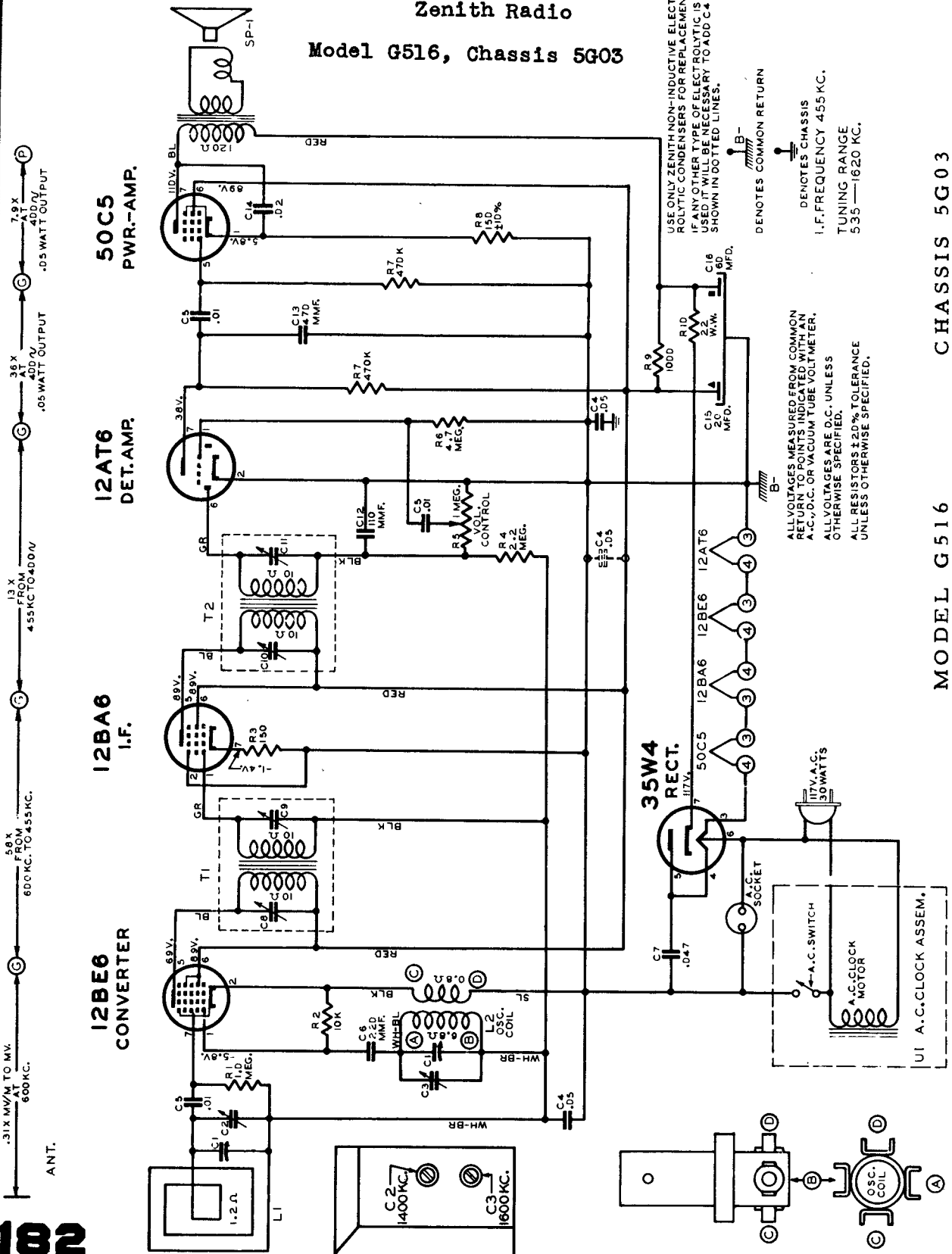

CHASSIS 5G03

MODEL G516

MANUAL OF 1950 MOST-OFTEN-NEEDED RADIO DIAGRAMS

MODEL G503 — CHASSIS 5G41

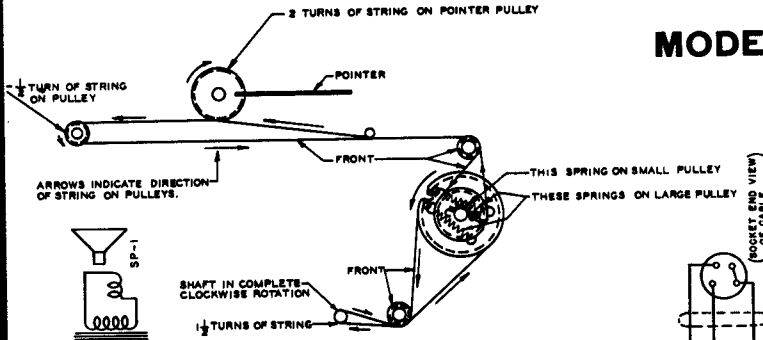

I.F. FREQUENCY 455 K.C.
TUNING RANGE
835-1850 K.C. STD. B.C.
BATTERY PACK NO. Z 909

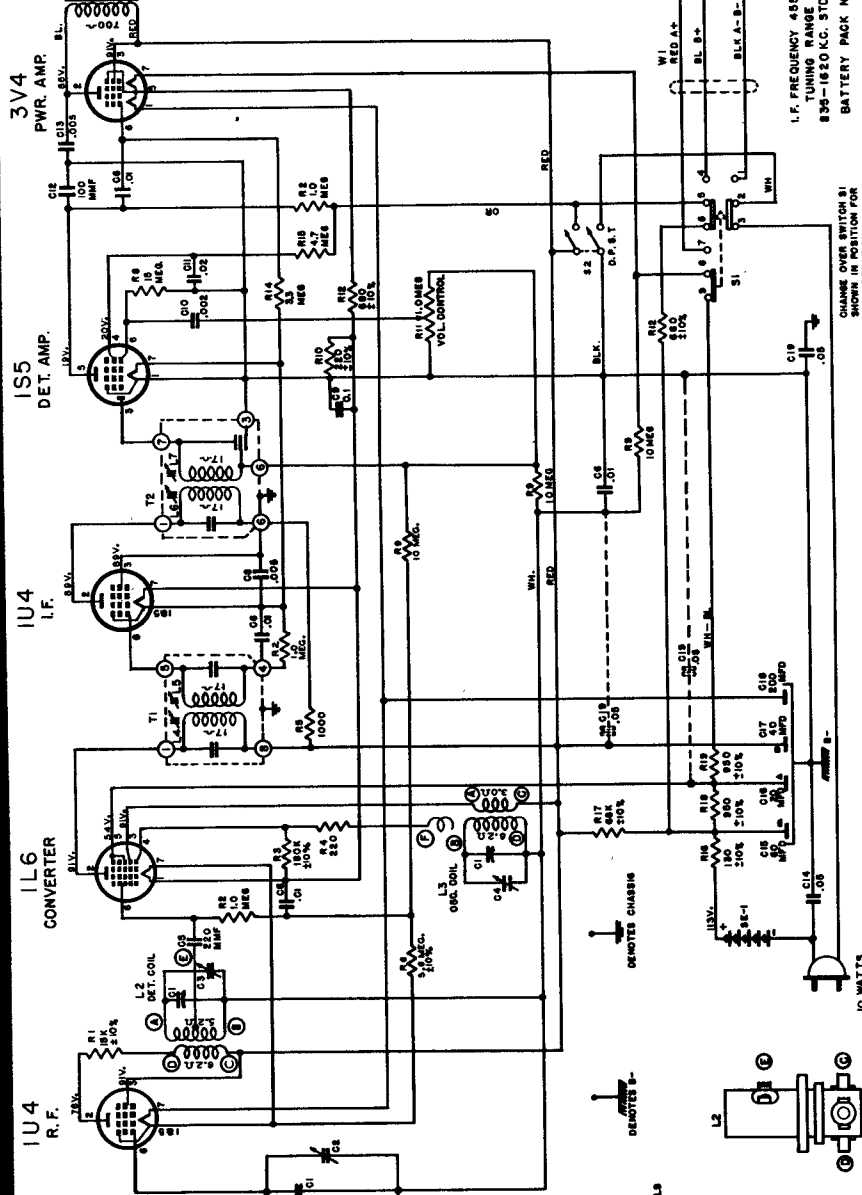

CHANGE OVER SWITCH S1
SHOWN IN POSITION FOR
A.C. OPERATION.

10 WETS. D.C.
INSERT A.C. PLUG HERE
FOR BATTERY OPERATION

L6 PRI. BOTTOM
L7 SEC. TOP
L8 PRI. TOP
L5 SEC. TOP
455 K.C.

C2 ANT. TRIMMER
C3 DET. TRIMMER
C4 OSC. TRIMMER

ON-OFF SWITCH
TUNING
VOLUME CONTROL

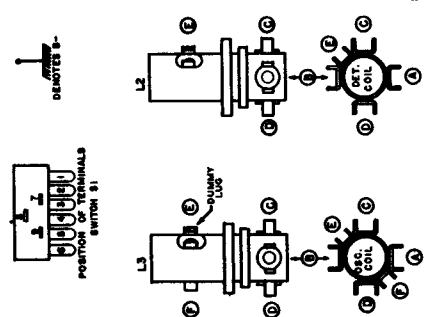

USE ONLY ZENITH NON-INDUCTIVE
ELECTRONIC CONDENSER FOR
REPLACEMENT. TYPE OF ELECTROLYTIC
IS USED IT WILL BE NECESSARY TO
ADD PARTS SHOWN IN BOTTLED LINES.
I.F. TRANSFORMER NUMBERING STARTS
WITH 1, TERMINALS AT FIRST TERMINAL
CLOCKWISE AND ADJACENT TO MAIN
AS VIEWED FROM BOTTOM OF CHASSIS
ALLOWED TO POINTS INDICATED WITH A
D.C. VACUUM TUBE VOLTMETER.
ALL RESISTORS 5.0% TOLERANCE
UNLESS OTHERWISE SPECIFIED.

MANUAL OF MOST-OFTEN-NEEDED RADIO DIAGRAMS

Zenith Radio Model G615 Chassis 6G05

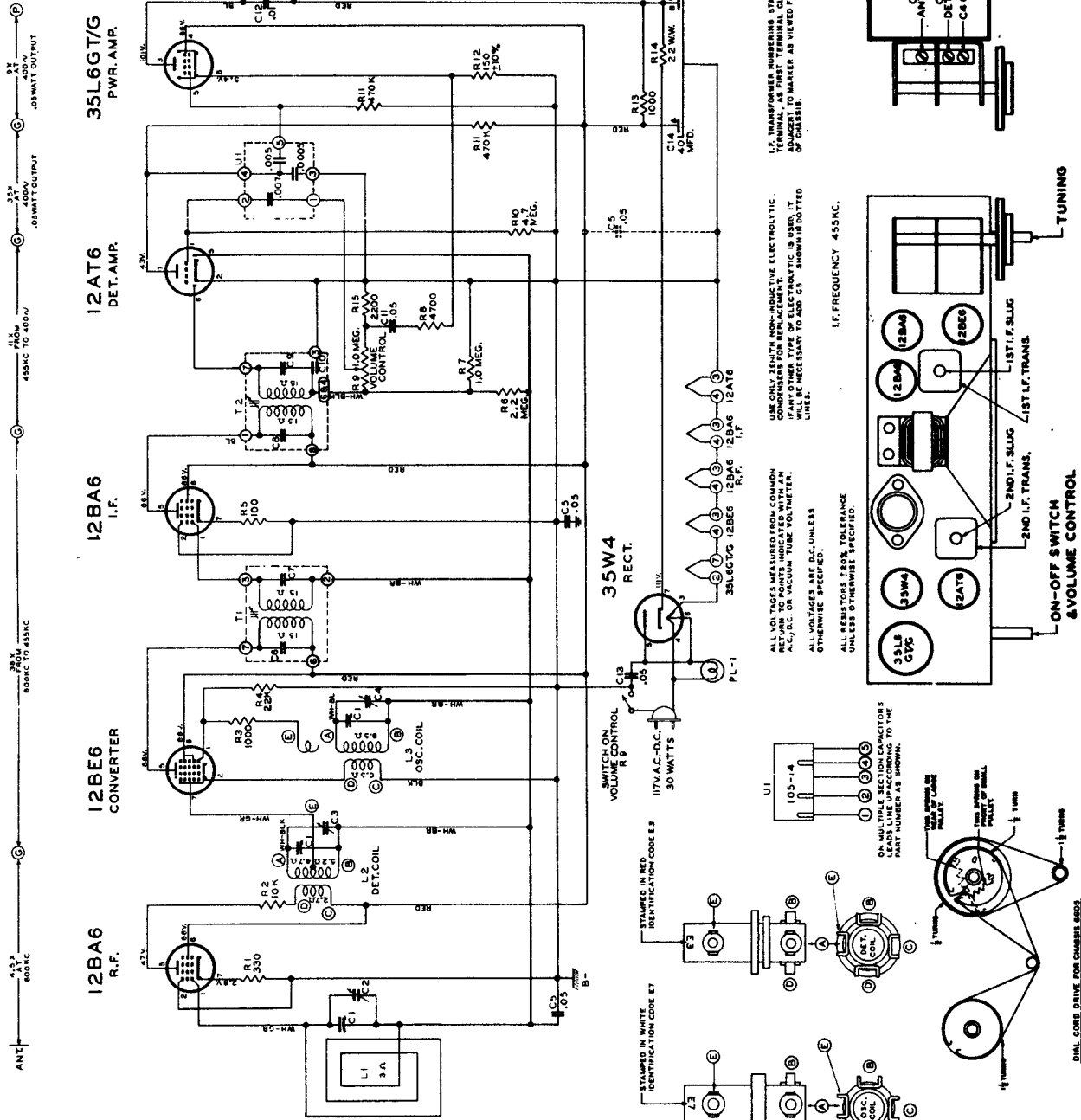

I.F. TRANSFORMER NUMBERING STARTS WITH #1 AT BOTTOM LEFT. IF OTHER TYPE OF ELECTRA-TIC IS USED, IT WILL BE NECESSARY TO ADD C3 SHOWN IN DOTTED LINE.

USE ONLY ZENITH NON-INDUCTIVE ELECTROLYTIC. IF ANY OTHER TYPE OF ELECTROLYTIC IS USED, IT WILL BE NECESSARY TO ADD C3 SHOWN IN DOTTED LINE.

ALL VOLTAGES ARE D.C. UNLESS OTHERWISE SPECIFIED.

ALL RESISTORS 20% TOLERANCE UNLESS OTHERWISE SPECIFIED.

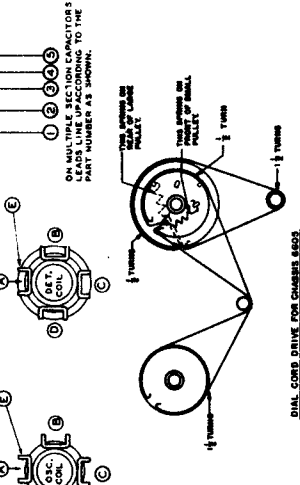
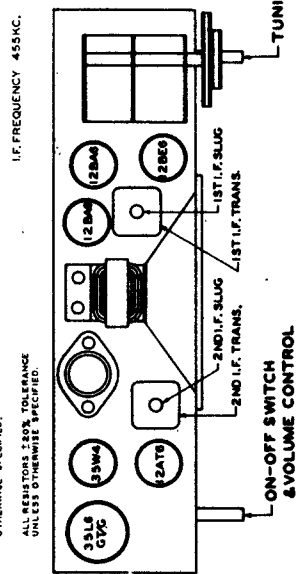
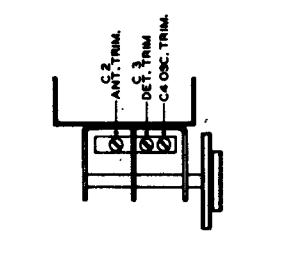

ALIGNMENT PROCEDURE

OPERATION	CONNECT OSCILLATOR TO	DUMMY ANTENNA	INPUT SIG. FREQUENCY	SET DIAL AT	TRIMMERS	PURPOSE
1	Converter Grid	.5 Mfd.	455 Kc.	600 Kc.	Adjust Primary & Secondary Slugs	For I.F. Alignment
2	Single Turn Loosely Coupled to Wave Magnet	--	1600 Kc.	1600 Kc.	C-4	Set Oscillator to Dial Scale.
3		--	1400 Kc.	1400 Kc.	C-3	Detector Alignment
4		--	1400 Kc.	1400 Kc.	C-2	Antenna Alignment

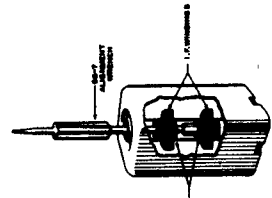

MANUAL OF 1950 MOST-OFTEN-NEEDED RADIO DIAGRAMS

ZENITH RADIO

MODEL 7H922
CHASSIS 7F02

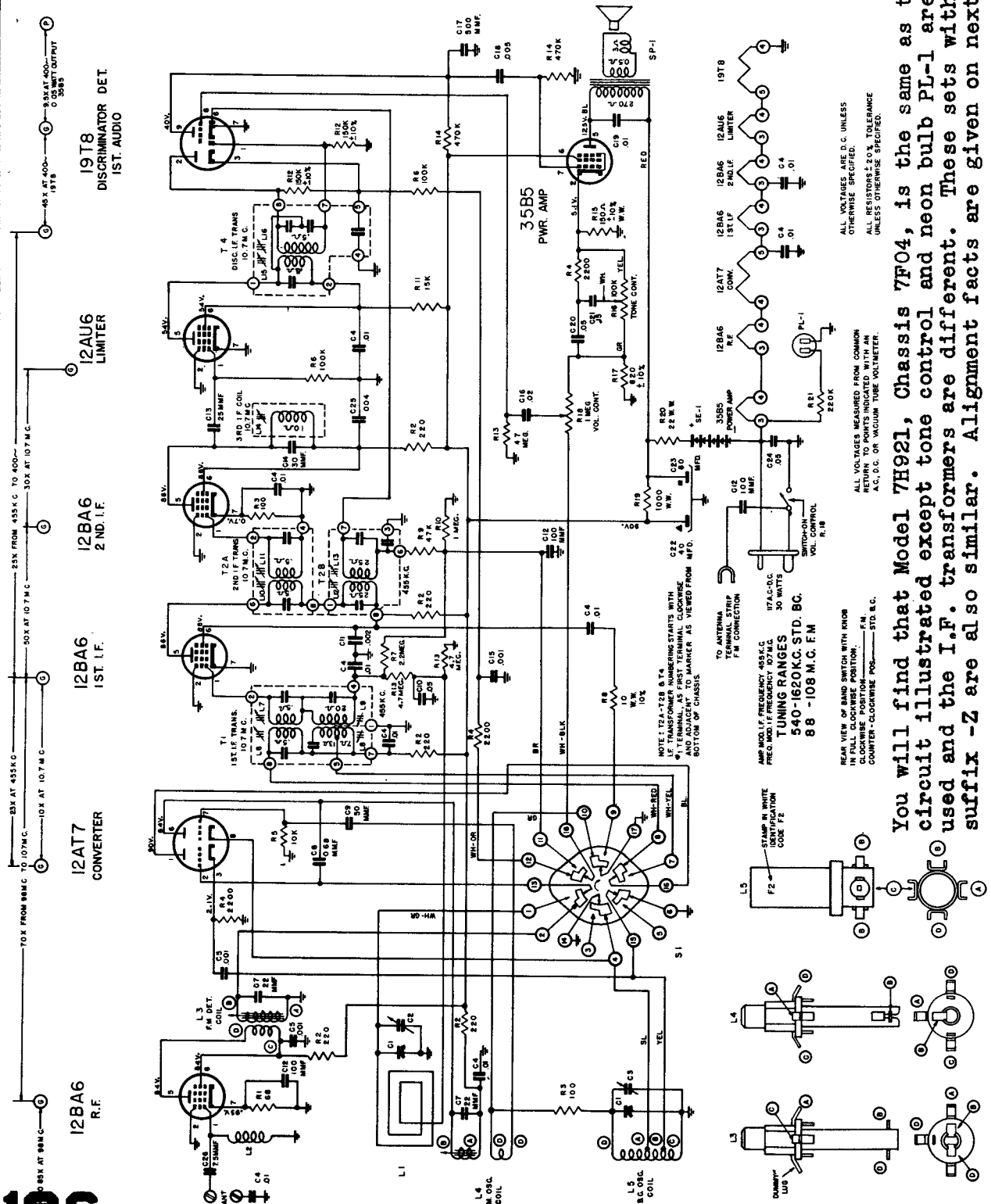

ALL VOLTAGES ARE D.C. UNLESS OTHERWISE SPECIFIED.
ALL RESISTORS ± 20% TOLERANCE UNLESS OTHERWISE SPECIFIED.

ALL VOLTAGES MEASURED FROM COMMON RETURN TO POINTS INDICATED WITH AN A.C. D.C. OR VACUUM TUBE VOLTMETER.

REAR VIEW OF BAND SWITCH WITH KNOB IN FULL CLOCKWISE POSITION. F.M. COUNTER-CLOCKWISE POS. STD. B.C.

TUNING RANGES
540-1620 K.C. STD. BC.
88-108 M.C. F.M.

NOTE: T1, T2, T3 & T4 I.F. TRANSFORMER NUMBERING STARTS WITH 1ST TERMINAL, AS FIRST TERMINAL, CLOCKWISE AND ADJUST TO MARKER AS VIEWED FROM POSITION OF CHASSIS.

IMP. MULTI-F. FREQUENCY 485 K.C. PRE-AMPL. I.F. FREQUENCY 107.7 M.C. 30 WATTS

TO ANTENNA TERMINAL STRIP F.M. CONNECTION

STAMP IN WHITE POSITION CODE F2

DUMMY LUG

You will find that Model 7H921, Chassis 7F04, is the same as the circuit illustrated except tone control and neon bulb PL-1 are not used and the I.F. transformers are different. These sets with a suffix -Z are also similar. Alignment facts are given on next page.

MANUAL OF 1950 MOST-OFTEN-NEEDED RADIO DIAGRAMS

ALIGNMENT PROCEDURE

Operation	Connect Oscillator To	Dummy Antenna	Input Signal Frequency	Band	Set Dial To	Adj. Trimmers	Purpose
1	Pin 2 12AT7 Converter 2 turns loosely cpd.	.05 Mfd.	455 Kc. Modulated	BC	600 Kc.	L8, 9, 12, 13	Align I. F. channel for maximum output.
2	to wavemagnet 2 turns loosely cpd.		1600 Kc. Modulated	BC	1600 Kc.	C3	Set oscillator to dial scale.
3	to wavemagnet		1400 Kc. Modulated	BC	1400 Kc.	C2	Align antenna stage.
4 (a)	Pin 1 (grid) on 12AU6 limiter.	.05 Mfd.	10.7 Mc. Unmodulated	FM		L15 coil slug Primary discr.	Align primary of discriminator for maximum reading.
5 (b)	Pin 1 (grid) on 12AU6 limiter.	.05 Mfd.	10.7 Mc. Unmodulated	FM		L16 coil slug sec. of discr.	Adjust secondary of discriminator for zero reading.
6 (c)	Pin 1 (grid) on 12BA6 2nd. IF.	.05 Mfd.	10.7 Mc. Unmodulated	FM		L14 Prim. of 3rd. IF trans.	Align 3rd. IF transformer for maximum reading.
7 (c)	Pin 1 (grid) on 12BA6 1st. IF.	.05 Mfd.	10.7 Mc. Unmodulated	FM		L10 and L11 Prim. and Sec. of 2nd. IF transformer	Align 2nd IF transformer for maximum reading.
8 (c)	Pin 2 (grid) on 12AT7 converter tube socket.	.05 Mfd.	10.7 Mc. Unmodulated	FM		L6 and L7 Prim. and Sec. of 1st. IF transformer.	Align 1st. IF transformer for maximum reading.
9 (c)	Antenna Post FM (Re-move line ant.)	270 ohms	98 Mc. Unmodulated	FM	98 Mc.	L4 Osc. Coil Slug	Set Oscillator to dial scale.
10 (c) (d)		270 ohms	98 Mc. Unmodulated	FM	98 Mc.	L3 Det. Coil Slug	Align det. stage to maximum reading.

The signal generator output should be kept just high enough to get an indication on the meter.

- (a) Vacuum Tube Voltmeter Lug 7 on discriminator transformer to chassis (half discriminator load).
- (b) Vacuum Tube Voltmeter Lug 5 on discriminator transformer to chassis (full discriminator load).
- (c) Vacuum Tube Voltmeter from Limiter Grid to Chassis.
- (d) Loosen Slugs by applying a hot iron to the cement.

A vacuum tube voltmeter with an isolation resistor of 2,000,000 ohms in series with the hot lead will serve for FM adjustments. This lead should be shielded.

An AC output meter connected across the primary or secondary of the output transformer will be satisfactory for all AM adjustments.

Zenith Model 7H922, Chassis 7F02,
also Model 7H921, Chassis 7F04,
and Model 7H921Z, Chassis 7F04Z.
Diagram material on previous page.

TUBE AND TRIMMER LOCATION

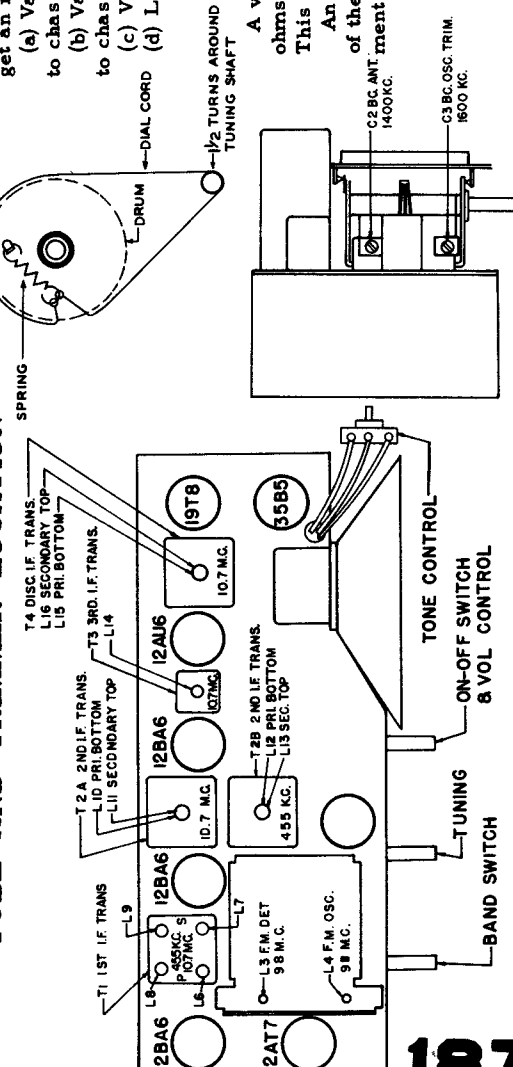

MANUAL OF 1950 MOST-OFTEN-NEEDED RADIO DIAGRAMS

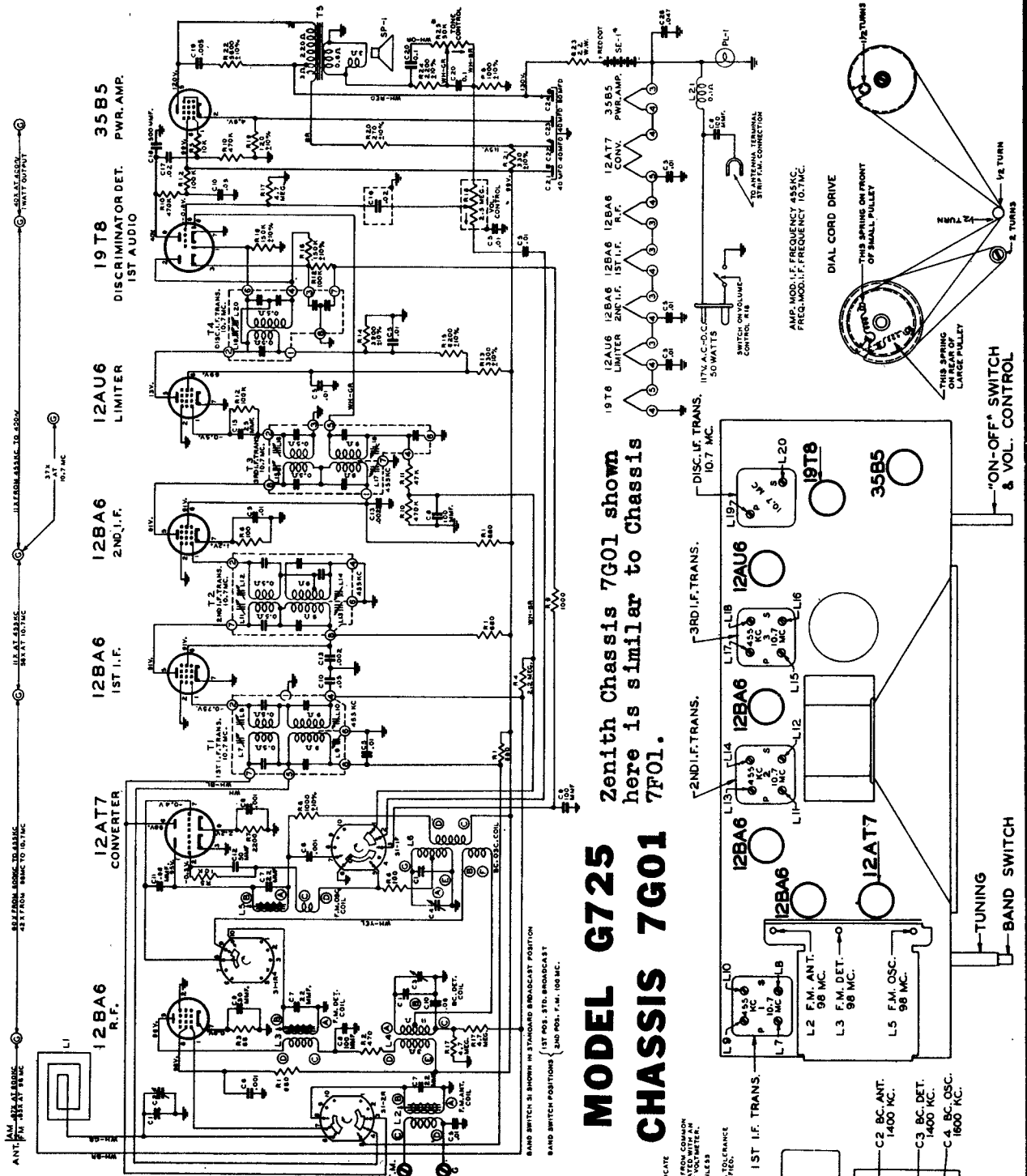

MODEL G725
CHASSIS 7G01

Zenith Chassis 7G01 shown here is similar to Chassis 7F01.

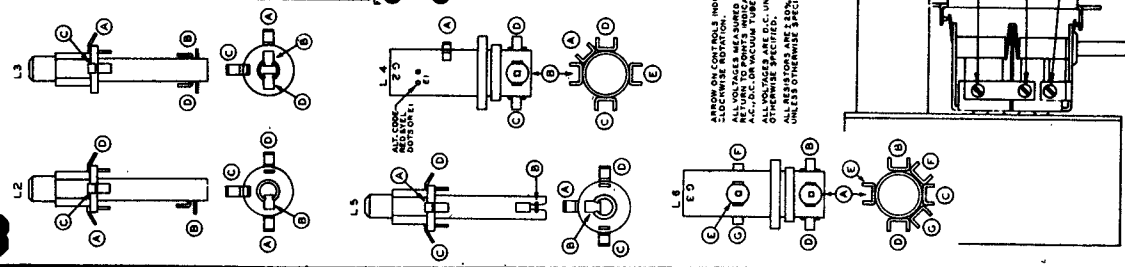

BAND SWITCH 3: SHOWN IN STANDARD BROADCAST POSITION
 BAND SWITCH POSITIONS: 1ST POS. STD. BROADCAST 2ND POS. 7.4 MC. 108 MC.

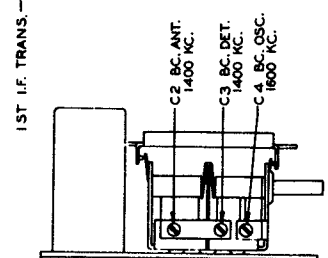

MANUAL OF 1950 MOST-OFTEN-NEEDED RADIO

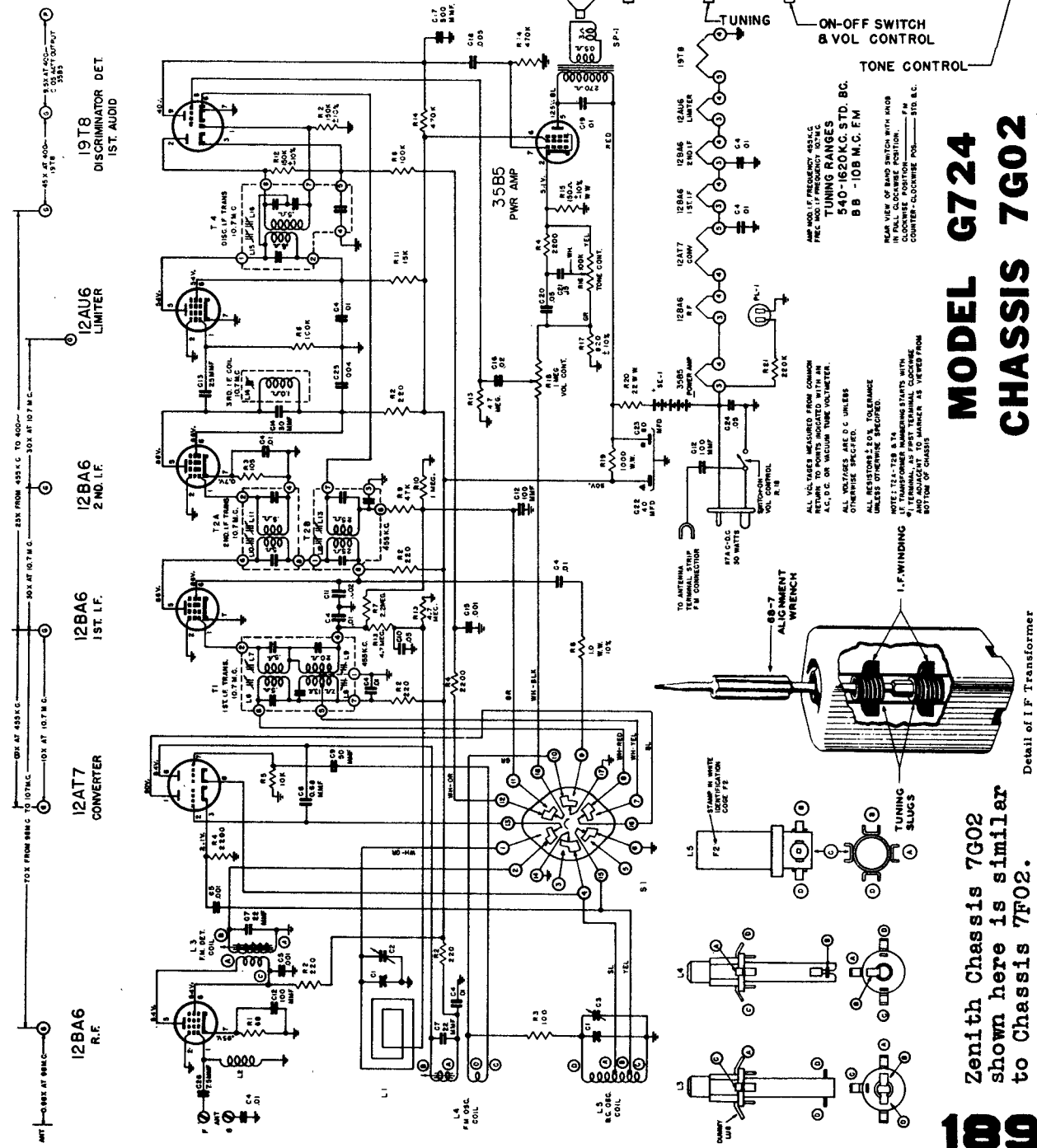
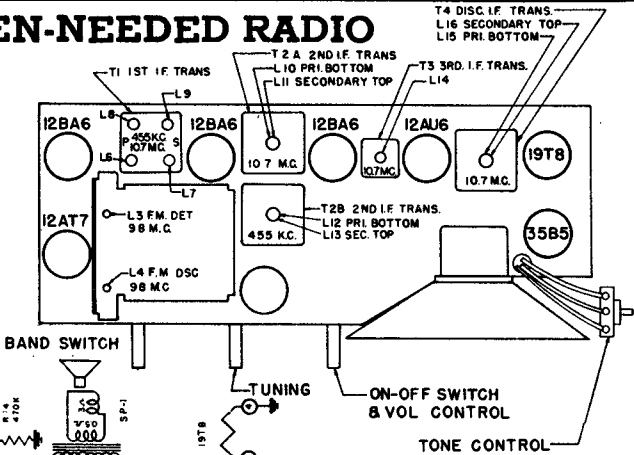
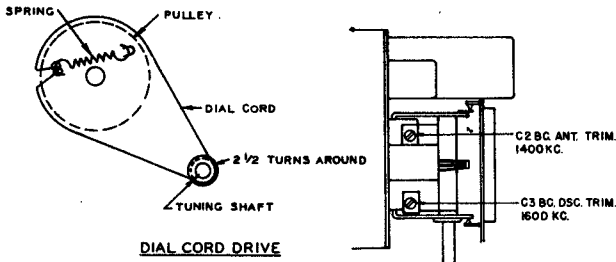

MODEL G724 CHASSIS 7G02

Zenith Chassis 7G02 shown here is similar to Chassis 7F02.

Detail of I F Transformer

MANUAL OF 1950 MOST-OFTEN-NEEDED RADIO DIAGRAMS

MODELS G881, G882, G883, G884 & G885

Zenith Radio CHASSIS 8G20

Model G844, Chassis 8G21 is similar, but less phono section.

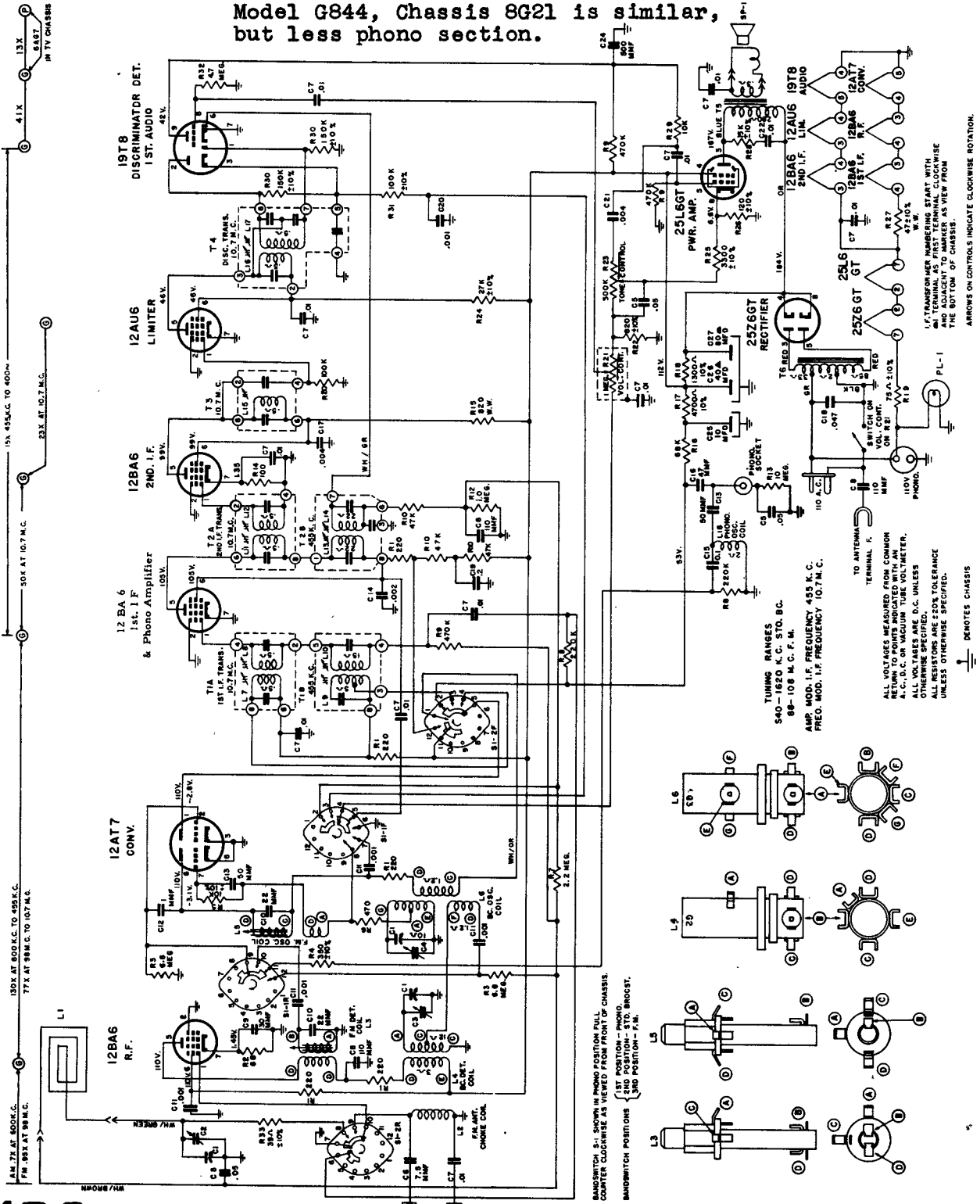

I.F. TRANSFORMER NUMBERING START WITH THIS POINT AND ADJACENT TO MARKER AS VIEW FROM THE BOTTOM OF CHASSIS.

ARROWS ON CONTROLS INDICATE COUNTERCLOCKWISE ROTATION.

TUNING RANGES
 540-1620 K.C. STD. BC.
 88-108 M. C. F. M.
 AMP. MOD. I.F. FREQUENCY 485 K.C.
 FREQ. MOD. I.F. FREQUENCY 10.7 M.C.

ALL VOLTAGES MEASURED FROM COMMON RETURN TO POINTS INDICATED WITH AN A.C., D.C. OR VACUUM TUBE VOLTMETER.
 ALL VOLTAGES ARE D.C. UNLESS OTHERWISE SPECIFIED.
 ALL RESISTORS ARE 5% TOLERANCE UNLESS OTHERWISE SPECIFIED.

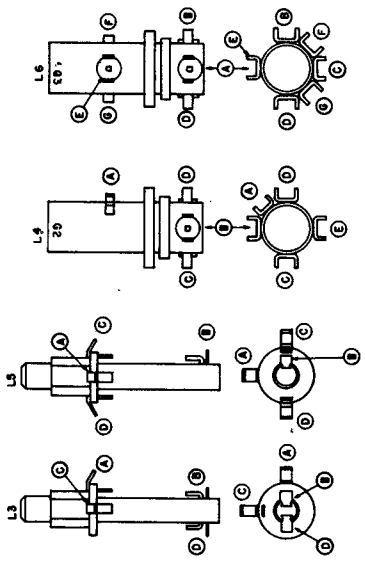

BAUDSWITCH S-1 SHOWN IN PHONO POSITION FULL COUNTER CLOCKWISE AS VIEWED FROM FRONT OF CHASSIS.
 (1ST POSITION - PHONO, 2ND POSITION - BROADCAST.)
 BAUDSWITCH POSITIONS

MANUAL OF 1950 MOST-OFTEN-NEEDED RADIO DIAGRAMS

ALIGNMENT PROCEDURE

Operation	Connect Oscillator To	Dummy Antenna	Input Signal Frequency	Band	Set Dial To	Adj. Trimmers	Purpose
1	Pin 2 12AT7 Converter 2 turns loosely cpd. to wavemagnet	.05 Mfd.	455 Kc. Modulated	BC	600 Kc.	L9, 10, 13, 14	Align 1 F. channel for maximum output.
2	2 turns loosely cpd. to wavemagnet		1600 Kc. Modulated	BC	1600 Kc.	C4	Set oscillator to dial scale.
3	2 turns loosely cpd. to wavemagnet		1400 Kc. Modulated	BC	1400 Kc.	C3, C2	Align detector and antenna stage.
4 (a)	Pin 1 (grid) on 12AU6 limiter.	.05 Mfd.	10.7 Mc. Unmodulated	FM		L16 coil slug Primary discr.	Align primary of discriminator for maximum reading.
5 (b)	Pin 1 (grid) on 12AU6 limiter.	.05 Mfd.	10.7 Mc. Unmodulated	FM		L17 coil slug sec. of discr.	Adjust secondary of discriminator for zero reading.
6 (c)	Pin 1 (grid) on 12BA6 2nd. I F.	.05 Mfd.	10.7 Mc. Unmodulated	FM		L15 Prim. of 3rd. IF trans.	Align 3rd. IF transformer for maximum reading.
7 (c)	Pin 1 (grid) on 12BA6 1st. IF.	.05 Mfd.	10.7 Mc. Unmodulated	FM		L11 and L12 Prim. and Sec. of 2nd. IF transformer.	Align 2nd IF transformer for maximum reading.
8 (c)	Pin 2 (grid) on 12AT7 converter tube socket.	.05 Mfd.	10.7 Mc. Unmodulated	FM		L7 and L8 Prim. and Sec. of 1st. IF transformer.	Align 1st. IF transformer for maximum reading.
9 (c)	Antenna Post FM (Re-move line ant.)	270 ohms	98 Mc. Unmodulated	FM	98 Mc.	L5 Osc. Coil Slug.	Set Oscillator to dial scale.
10 (c) (d)		270 ohms	98 Mc. Unmodulated	FM	98 Mc.	L3 Det. Coil Slug	Align det. stage to maximum reading.

ZENITH RADIO CORP.

Alignment instructions for Chassis 8G20, 8G21, used in Models G844, G881, G882, G883, G884, and G885.

Alignment of this chassis will in most cases be unnecessary unless an IF or RF transformer is replaced or the adjustments have been tampered with.

Correct alignment can only be made if the following procedure is followed:

A vacuum tube voltmeter with an isolation resistor of 2,000,000 ohms in series with the hot lead will serve for FM adjustments. This lead should be shielded.

An AC output meter connected across the primary or secondary of the output transformer will be satisfactory for all AM adjustments.

The signal generator output should be kept just high enough to get an indication on the meter.

(a) Vacuum Tube Voltmeter Lug 7 on discriminator transformer to chassis (half discriminator load).

(b) Vacuum Tube Voltmeter Lug 5 on discriminator transformer to chassis (full discriminator load).

(c) Vacuum Tube Voltmeter from Limiter Grid to Chassis.

(d) Loosen Slugs by applying a hot iron to the cement.

Schematic diagram on previous page.

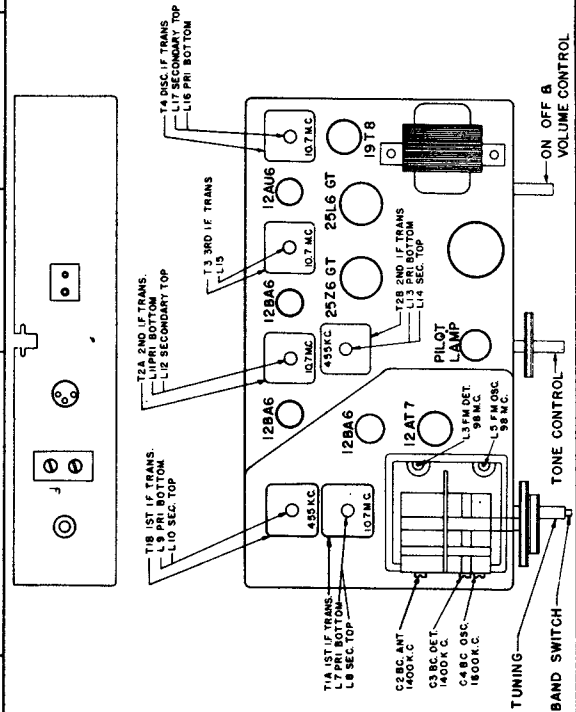

MANUAL OF 1950 MOST-OFTEN-NEEDED RADIO DIAGRAMS

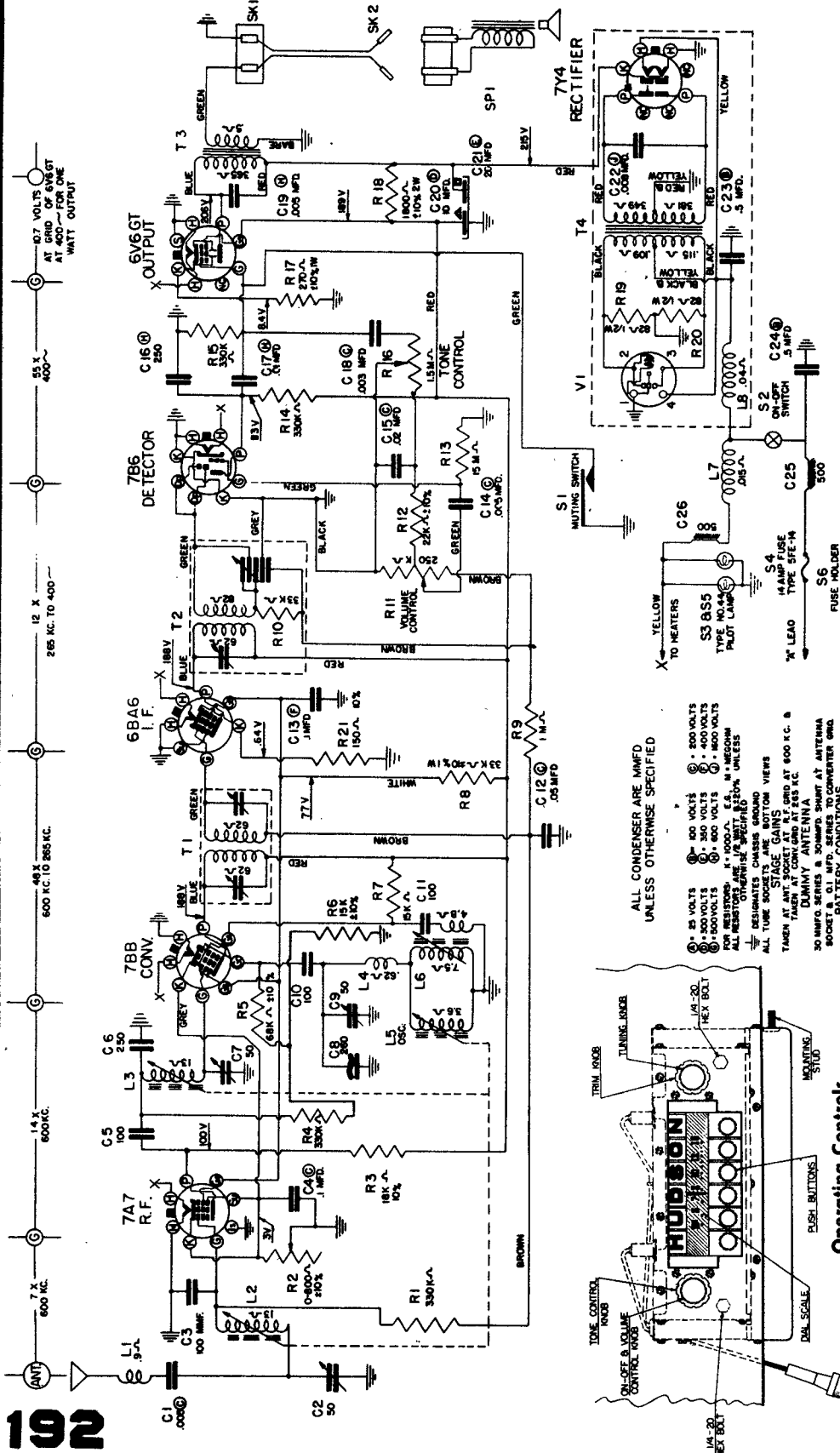

SCHEMATIC DIAGRAM FOR 6 TUBE HUDSON 6MH889

HUDSON 6MH889
 TUNING RANGE 540 KC. TO 1600 KC.
 ZENITH RADIO CORPORATION

HUDSON AUTOMOBILE RECEIVER MODEL 6MH889—CHASSIS 6E89

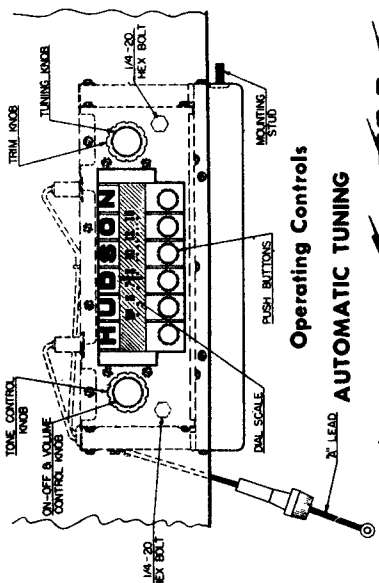

ALL CONDENSERS ARE MMFD UNLESS OTHERWISE SPECIFIED

- ① 25 VOLTS ⑥ 500 VOLTS
- ② 50 VOLTS ⑦ 300 VOLTS
- ③ 100 VOLTS ⑧ 400 VOLTS
- ④ 200 VOLTS ⑨ 600 VOLTS
- ⑤ 300 VOLTS ⑩ 1000 V. E.S. 1/2" W. MESSON

RESISTORS ARE OTHERWISE SPECIFIED BY VALUES

ALL TUBE SOCKETS ARE 9-PIN

STAGS ARE TAKEN FROM VIEWS TAKEN AT ANT. SOCKET AT R.F. GRID AT 600 K.C. & 30 MMFD. SHUNTING ANTENNA LEAD AT ANTENNA SOCKET & 0.1 MMFD. SERIES TO CONVERTER GRID

BATTERY CONDITIONS

4.3 VOLTS AT STORAGE BATTERY TERMINALS WITH POSITIVE GROUNDING

TEST CONDITIONS

NO-LOAD CONTROL SET AT MAXIMUM TONE CONTROL SET VOLTS WITH NO RECORDING SIGNAL

WITH 1000 OHM PER VOLT METER