

Most - Often - Needed

1951

RADIO
DIAGRAMS

Compiled by

M. N. BEITMAN

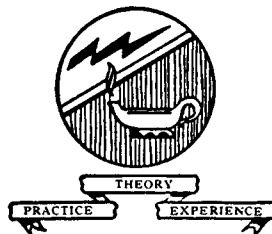

SUPREME PUBLICATIONS
CHICAGO

MANUAL OF 1951 MOST-OFTEN-NEEDED RADIO DIAGRAMS

Index

Always use this Index to find needed material in this Volume 11, 1951 RADIO Diagram manual. You will find the various makes of radios listed in alphabetical order by manufacturer's name. Under each make, models or chassis are listed in numerical order at the left of the column while the corresponding page numbers are given to the right.

Admiral Corp.	
4T1	6
4T11	6
4W1	6
4W18	6
4W19	6
5E2	7
5E21	7
5E22	7
5E23	7
5G2	8
5G21	8
5G21/15	8
5G22	8
5G22/15	8
5G23	8
5G23/15	8
5J2	7
5J21	7
5J22	7
5J23	7
6J2	9
6J21	9
6J22	9
Air Chief	
See Firestone	
Airline	
See Montgomery	
Allied Radio Corp.	
5G563	59
Arvin Industries	
RE-277	13
RE-277-1	13
RE-280	11
RE-281	10
RE-284	12
446P	11
450T	10
451T	10
460T	12
461T	12
480TFM	13
481TFM	13

Bendix Radio	
951	14
951W	14
Cadillac	
7260405	135
7260905	135
Capehart	
TC-20	15
T-30	16
C-297	15
Chevrolet	
986515	140
Coronado	
T-64	42
05RA4-43-9876A,	
and -B	43
05RA33-43-5016A	41
05RA33-43-8120A	42
05RA33-43-8136A	44
05RA33-43-8137A	44
15RA38-43-8235A	43
15RA38-43-8236A	43
Crosley Corp.	
10D	17
10D-1	17
D10BE	17
D10CE	17
D10GN	17
D10RD	17
D10TN	17
D10WE	17
11-100U	17
11-101U	17
11-102U	17
11-103U	17
11-104U	17

Crosley, continued	
11-105U	17
11-106U	19
11-107U	19
11-108U	19
11-109U	19
11-110U	19
11-111U	19
11-112U	19
11-113U	19
11-114U	18
11-115U	18
11-116U	18
11-117U	18
11-118U	18
11-119U	18
11-120U	21
11-121U	21
11-122U	21
11-123U	21
11-124U	21
11-125U	21
11-126U	20
11-127U	20
11-128U	20
11-129U	20
11-130U	19
11-132U	19
11-301U	22
11-302U	22
11-303U	22
11-304U	22
11-305U	22
11-444MU	23
11-474BU	23
11-550MU	24
11-560BU	24
D25BE	21
D25CE	21
D25GN	21
D25MN	21
D25TN	21
D25WE	21
299	19
301	17
302	19
303	22

MANUAL OF 1951 MOST-OFTEN-NEEDED RADIO DIAGRAMS

Crosley, continued

311, 311-1	21
312	20
330	17
also on	18
330-1	18
332	23
337	24

Delco

See United Mot.

DeWald Radio Mfg.

E-520	25-26
E-522	26

Emerson Radio

625	28
634B	27
641B	29
646A, 646B	30
659B	31
671D	32
672B	27
679B	33-34
120097-B	27
120105B	28
120116B	33-34
120121A	30
120121B	30
120125B	29
120126B	31
120137D	32

Fada Radio

P-111	35
P-130	36

Firestone Tire

4-A-70	39
4-A-85	40
4-A-89	40
4-B-56	38
4-B-57	38
4-B-58	37
4-B-60	38
4-B-61	37
4-B-62	38
4-C-18	39

Gamble-Skogmo See Coronado

General-Electric

400	45
401	45
402	45
404	46
405	46
408	47
410	46
411	45
510F	48
511F	48
512F	48
513F	48
515F	48
516F	48
517F	48
518F	48
521F	48
522F	48
605	49
606	49
610	50
611	50
740	51
752	52
753	52

Hallicrafters, Inc.

5R10	53-54
5R11	44
5R12	44
5R13	44
5R14	44

Hoffman Radio

165	55
204	55
205	55

Jewel Radio

955	57
956	57
960, 960U	58
961	58
5010U	56
5050	56
5057	58

Kaiser-Frazer

100170	136
100205	138

Knight

5G563	59
-------	----

Montgomery Ward

05BR-1536A,B	62
05BR-1537A,B	62
05BR-2756A,B	68
05WG-2748C,D	63
05WG-2748E,F	63
05WG-2751A	60-61
05WG-2752	61
05WG-2752B	60-61
05WG-2752C	61
15BR-1543A	64
15BR-1544A	64
15BR-1547A	65
15BR-2757A	68
15GCB-1583	66
15GCB-1584	66
15HA-1553A	67
15HA-1554A	67
15WG-1813B	63
15WG-2752D	61
15WG-2752E	61
94WG-2748A	63
94WG-2748B,C	63

Motorola, Inc.

BKOA	76
GMOT	76
HNO	76
ILOTC	76
OEO	76
PCO	76
1A	73
1B	74
CT1	73
CT1M	74
KR1	73
NH1C	75
SR1B	74
5C1	87
5C2	87
5C3	87
5C4	87
5C5	87
5C6	87
5H11, -U	89
5H12, -U	89
5H13, -U	89
5J1, -U	91
5J2, -U	91
5L1, -U	91
5L2, -U	91
5R11, A,AU,U	88

MANUAL OF 1951 MOST-OFTEN-NEEDED RADIO DIAGRAMS

Motorola, cont.

5R12, A,AU,U	88
5R13, A,AU,U	88
5R14, A,AU,U	88
5R15, A,AU,U	88
5R16, A,AU,U	88
5X11U	89
5X12U	89
5X13U	89
6L1	92
6L2	92
6X11U	90
6X12U	90
CT8A	76
8FM21	94
8FM21B	94
GM9TA	76
KR9A	76
PC9A	76
SR9A	76
10A	76
51L1U	91
51L2U	91
51M1U	93
51M2U	93
ST-54 is similar to ST-60	
AT-58 Tuner 69-72	
ST-60 Tuner 81-86	
61L1	92
61L2	92
ST-78 Tuner 81-86	
HS-224	91
HS-226	92
HS-228	87
HS-242	88
HS-243	89
HS-244	89
HS-245	90
HS-247	94
HS-250	91
HS-254	88
HS-256	89
HS-258	87
HS-262	87
HS-270	87
HS-271	87
HS-272	87
HS-280	88
HS-281	88
HS-283	93
401	78
451	78
501	79
601	79
606	80
701	77
801	77

Oldsmobile

982697	137
982698	137

Olympic Radio

489	95
-----	----

Packard

416394	135
--------	-----

Philco Corp.

51-530	96
51-532	96
51-534	96
51-537	97
51-537-I	97
51-538	97
51-930	101
51-931	101
51-932	101
51-1330	99
51-1730	100
51-1730(L)	100
51-1731	102-104
51-1732	102-104
CR-501	98
CR-503	98
CR-505	98

Pontiac

984592	139
--------	-----

R.C.A. Victor

45-EY-1	105
45-EY-2	106
45-EY-3	105
45-EY-15	105
BX57	107
A-101	109
A-108	109
RS-132F, -H	105
RS-136, -A	105
RS-138, -A	106
RP-190	111-118
B-411	108
X551	110
X552	110
RC-1088A	107
RC-1088C	107
RC-1089B, -C	110
RC-1096	109
RC-1098, -A	108

Sears, Roebuck

4	119
69	123
215	120
225	122
9103	121
100.201	123
110.490	121
478.233	119
528.171	122
528.171-1	122
528.174	120

Silvertone

See Sears, Roeb.

Sonora Radio

105	124
314	124
315	124

Sparks, Withington

See Sparton

Sparton

8M10	125-126
8W10	125
141X	125-126
141XX	125
142X	125-126
142XX	125
1040X	125-126
1040XX	125
1041X	125-126
1041XX	125
1085	125
1086	125
1090	125
1091	125

Stewart-Warner

9153-A	127
9154-C	128
9154-CZ	128
9156-A	129

Stromberg-Carlson

1507	130
1608	131-132

Trav-ler Radio

5022	133
5060	133
5061	133
5066	134

Truetone

see Western Auto

United Motors

100170	136
100205	138
416394	135
982697	137
982698	137
984592	139
986515	140
7260405	135
7260905	135

Western Auto

4P11	146
5D162	144
5D165	145
8AF29	143
25C23-11	147
25D26-006	141
27A96-952	142
225D26-002	141
D-1034A,B,C	142
D-1046A,B,C	142
D-1046D	142
D-2017,-A,-B	141
D-2018,-A,-B	141
D-2026	143
D-2042	144
D-2102A	145
D-2103A	145
D-3120A	146
D-4142A	147

Westinghouse Elect.

H-307T7	149
H-308T7	149
H-309P5	151
H-309P5U	151
H-316C7	149
H-317C7	149
H-318T5, -U	148
H-320T5, -U	148
H-321T5, -U	148
H-322T5, -U	148
H-323T5, -U	148
H-324T7, -U	149
H-325T7, -U	149
H-326C7	149
H-328C7	149
H-334T7U	149-150
H-335T7U	149-150
H-336T5U	148
H-337T5U	148
H-338T5U	148
H-341T5U	148
H-342P5U	151
H-343P5U	151
V-2136	149
V-2136-1	149
V-2136-2	149
V-2136-4	149
V-2136-5U	149
V-2156	151
V-2156-1U	151
V-2157, -R	148
V-2157-1	148
V-2157-1U	148
V-2157-2	148
V-2157-2U	148
V-2157-4U	148

Zenith Radio Corp.

5H01	152
6H01	153
6H02	153
7H02	154
7H02Z	154
7H04, -Z	155
8H20	156-157
10H20	158
H511	152
H511W, -Y	152
H661E	153
H661R	153
H665	153
H665R, -RZ	153
H665Z	153
H723, -Z	155
H724, -Z	154
H880R	157
H880RZ	156-157
H1083E	158
H1086R	158
H1087R	158
S14028	159
S14029	159
S14030	159
S14031	159
S14036	159

MANUAL OF 1951 MOST-OFTEN-NEEDED RADIO DIAGRAMS

Admiral

CHASSIS 4W1 and 4T1
 MODELS 4W18, 4W19, and 4T11

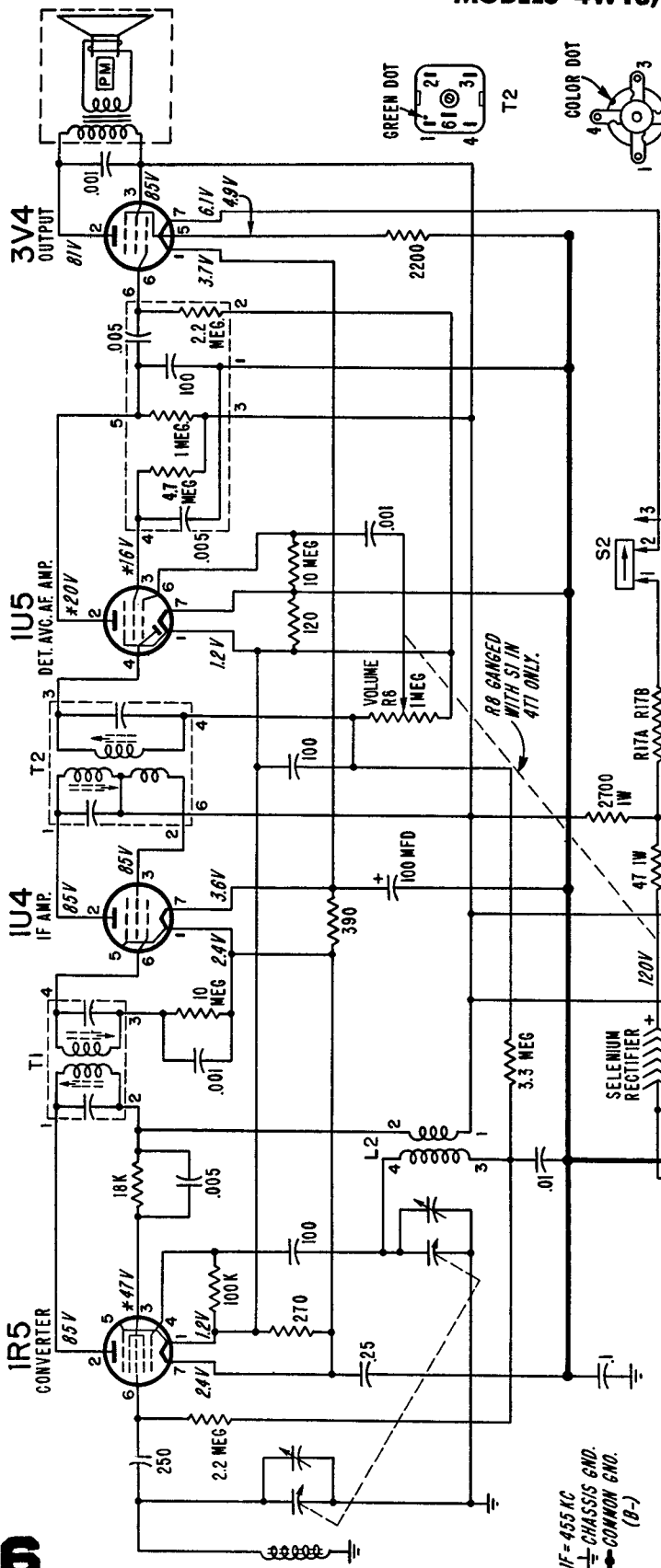

IF = 455 KC
 CHASSIS GND.
 COMMON GND. (B-)

110 VOLTS 60 CYCLE
 AC OR DC

S2 SHOWN IN POSITION FOR OPERATION FROM POWER LINE

*These readings will be either lower or practically zero if taken with a 1000 ohm-per-volt meter

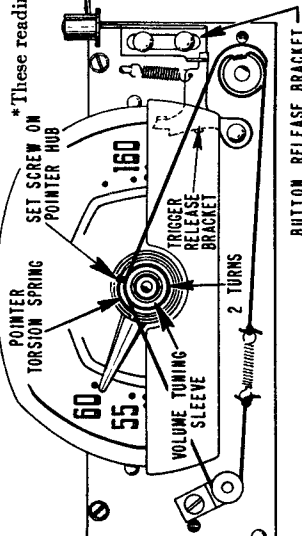

POINTNER TORSION SPRING

SET SCREW ON POINTNER HUB

TRIGGER RELEASE BRACKET

VOLUME TUNING SLEEVE

2 TURNS

BUTTON RELEASE BRACKET

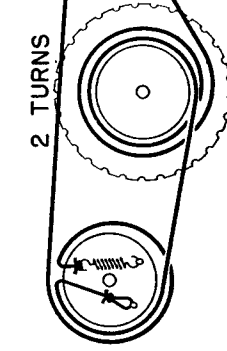

2 TURNS

VOLUME OFF

MAINPIN SPRING

POINTNER HUB

POINTNER

POINTNER SPRING

VOLUME DRIVE PULLEY

FIBRE WASHER

VOLUME TUNING KNOB

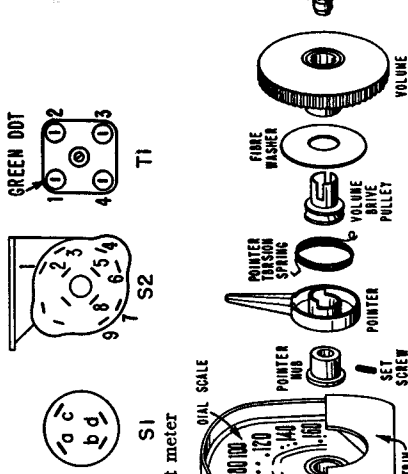

TUNING KNOB

VOLUME TUNING KNOB

FIBRE WASHER

VOLUME DRIVE PULLEY

POINTNER SPRING

POINTNER

POINTNER HUB

DIAL HOUSING

OIAL SCALE

DIAL TRAIN

SET SCREW

MAINPIN SPRING

70.00

60

55.1

MANUAL OF 1951 MOST-OFTEN-NEEDED RADIO DIAGRAMS

Admiral

CHASSIS 5E2
MODELS 5E21, 5E22, 5E23

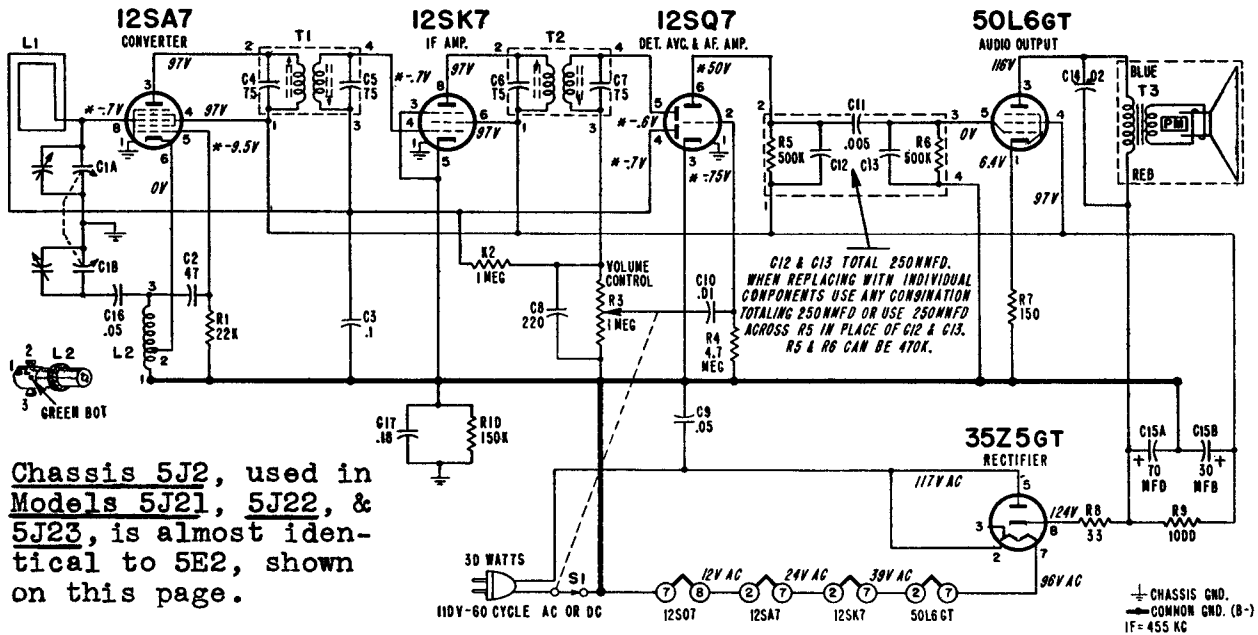

Chassis 5J2, used in Models 5J21, 5J22, & 5J23, is almost identical to 5E2, shown on this page.

*These readings will be either lower or practically zero if taken with a 1000 ohm-per-volt meter.

ALIGNMENT PROCEDURE

- Connect output meter across speaker voice coil.
- Turn receiver volume control full on.
- Use an isolation transformer if available, otherwise connect a .1 mfd. condenser in series with low side of signal generator and connect to chassis.

VOLTAGE DATA

All readings made between tube socket terminals and B minus (terminal of On-Off switch).

Dial turned to low frequency end; volume control at minimum.

Measured on 117 Volts AC line.

Volts measured with Vacuum Tube Voltmeter.

Step	Dummy Antenna in Series with Signal Generator	Connection of Signal Generator (High Side)	Signal Generator Frequency	Receiver Gang Setting	Trimmer Description	Trimmer Designation	Type of Adjustment
1	250 mmfd. condenser	Antenna stator of tuning condenser	455 KC	Gang fully open	2nd IF 1st IF	*A, B *C, D	Maximum Output
2	250 mmfd. condenser	Antenna stator of tuning condenser	1620 KC	Gang fully open	Oscillator (on gang)	E	Maximum Output
3	Loop of several turns of wire or place generator lead close to receiver loop for adequate signal pickup.	No actual connection (signal by radiation)	1400 KC	Tune in generator signal	Antenna (on gang)	F	Maximum Output
4	Mount and set dial pointer as shown in Pointer Setting and Dial Cord Stringing Diagram.						

*Adjustments A and C made from the underside of the chassis.

TUBE AND TRIMMER LOCATION

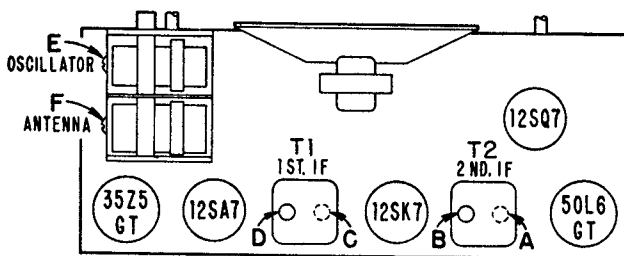

Adjustments A and C are made from underside of chassis.

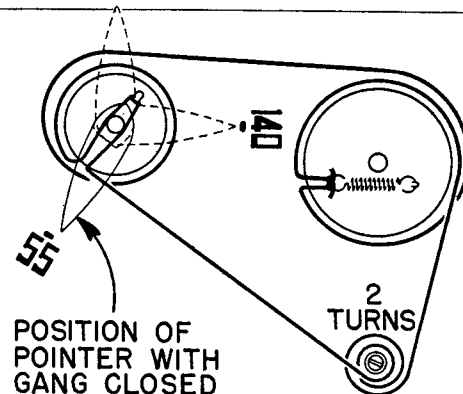

POSITION OF POINTER WITH GANG CLOSED

MANUAL OF 1951 MOST-OFTEN-NEEDED RADIO DIAGRAMS

Admiral

CHASSIS 5G2
 MODELS 5G21, 5G22, 5G23,
 5G21/15, 5G22/15, 5G23/15

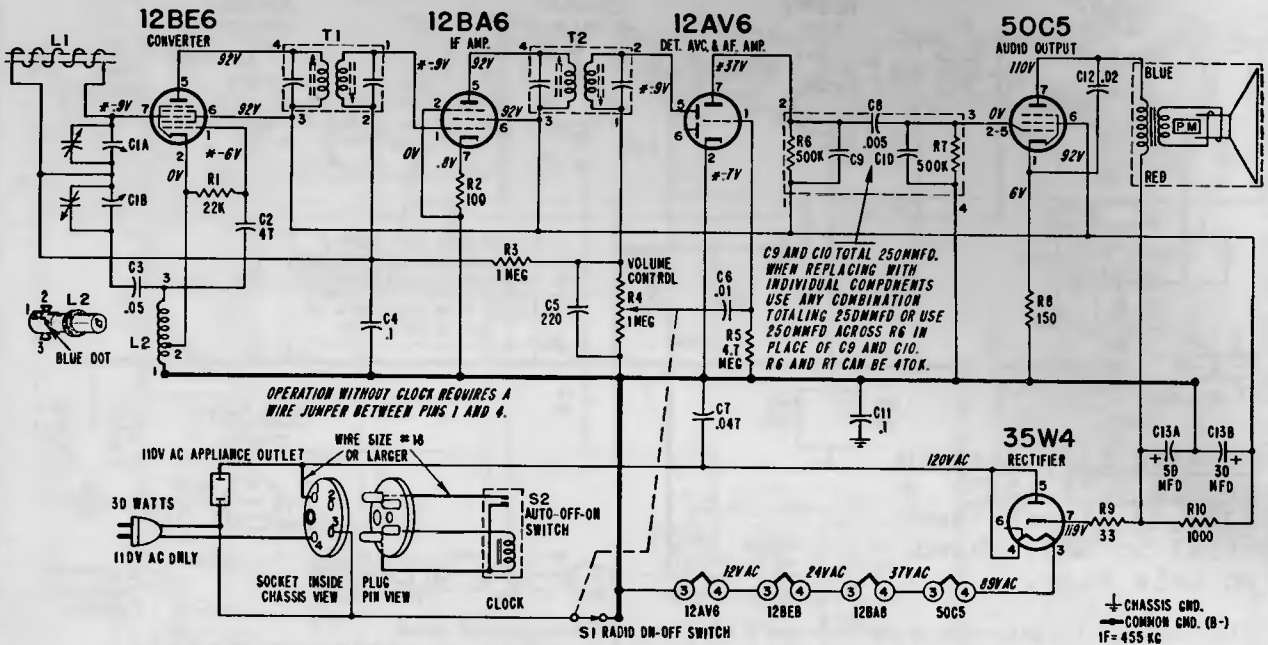

*These readings will be either lower or practically zero if taken with a 1000 ohm-per-volt meter.

OPERATING RADIO MANUALLY

To operate the radio manually, the "Auto-Off-On" switch must be in the "On" position or the radio will not operate.

The radio on-off switch will turn the radio on or off, but will have no control over the appliance or the clock.

TO REMOVE CLOCK from CABINET

(Radio chassis need not be removed when removing clock)

1. Remove the back from radio cabinet.
2. Remove the clock plug from the socket on top of the radio chassis, by removing screw from top of plug and gently prying plug out from socket.
3. Turn the slumber switch to the "60" position.
4. Remove the 3 nuts which hold the clock back cover to the clock.
5. Carefully pull the clock through the front of the cabinet while twisting it slightly to eliminate binding.

TO REMOVE FIELD and COIL ASSEMBLY or TO REMOVE ROTOR

The field and coil assembly and the rotor can be easily removed after the two screws which mount the nameplate are removed.

Note that when the rotor is replaced, the gear on the rotor must drop into the hole in the center of the gear plate and mesh with the clock gear.

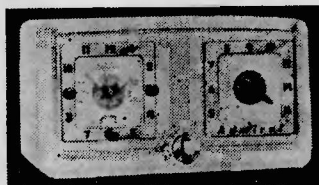

VOLTAGE DATA

Voltages shown on schematic diagram

- All readings made between tube socket terminals and B minus (terminal of On-off switch).
- Measured on 117 Volt AC line.
- Volume control minimum; dial turned to low frequency end.
- Voltages measured with Vacuum Tube Voltmeter.

TUBE AND TRIMMER LOCATION

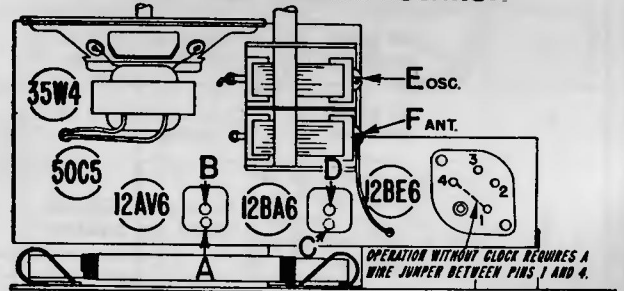

Adjustments A and C made from underside of chassis.

DIAL STRINGING AND POINTER SETTING

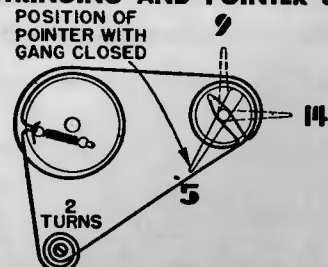

Dial stringing and pointer with solid lines shown with gang closed. Dashed line pointer positions (1400 KC and 900 KC) shown when tuning condenser is tuned to generator signal.

MANUAL OF 1951 MOST-OFTEN-NEEDED RADIO DIAGRAMS

Admiral

CHASSIS 6J2
MODELS 6J21, 6J22

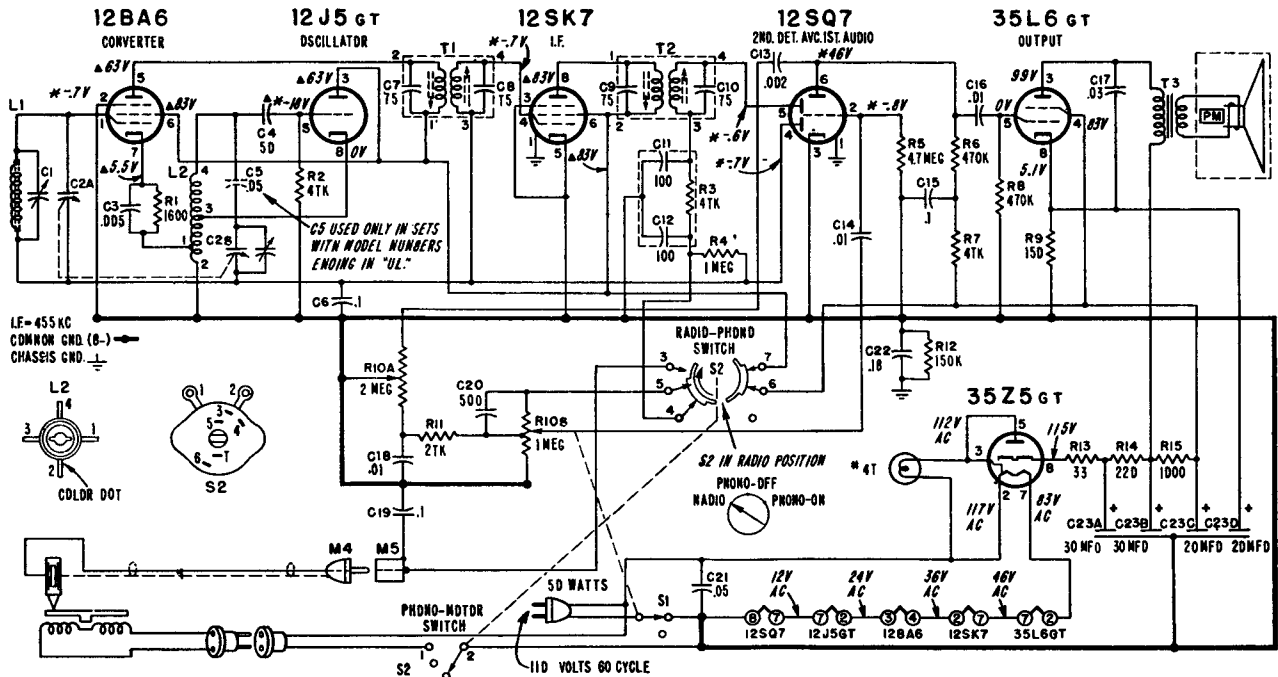

*These readings will be either lower or practically zero if taken with a 1000 ohm-per-volt meter.
▲ These readings will be zero on "Phono"; all other DC readings may be slightly higher.

Step	Dummy Antenna in Series with Signal Generator	Connection of Signal Generator (High Side)	Signal Generator Frequency	Receiver Gang Setting	Trimmer Description	Trimmer Designation	Type of Adjustment
1	250 mmfd. condenser	Tuning condenser, antenna stator	455 KC	Gang fully open	2nd IF 1st IF	*A, B *C, D	Maximum output
2	250 mmfd. condenser	Tuning condenser, antenna stator	1620 KC	Gang fully open	Oscillator	F	Maximum output

Mount dial pointer. Set pointer to horizontal position with tuning condenser tuned to 1400 KC generator signal (see illustration below). Rotate the tuning condenser until the pointer is in a vertical position (900 KC), then slip chassis in cabinet, carefully guiding the pointer so that it locates between the dial escutcheon and the cabinet. Install antenna and chassis mounting bolts. The pointer and escutcheon may be mounted after installing the chassis in cabinet as follows: Set pointer to horizontal position with gang tuned to 1400 KC signal. Place escutcheon on cabinet. With long nose pliers slip the hairpin ends of the escutcheon mounting springs in holes of escutcheon tabs.

3	Loop of several turns of wire, or place generator lead close to receiver antenna for adequate signal pickup.	No actual connection (signal by radiation)	1400 KC	Tune in generator signal	Antenna	†F	Maximum output
---	--	--	---------	--------------------------	---------	----	----------------

*Adjustments A and C made from the underside of the chassis. If IF transformers have hollow core slugs, these adjustments may all be made from the top of chassis, if you use alignment tool #98A30-7 obtainable from your Admiral distributor. The bottom IF slug adjustment may be reached through the hollow core in the upper slug.
† Antenna Trimmer "F" should be aligned after chassis and antenna are mounted in cabinet.

DIAL STRINGING AND POINTER SETTING

Dial stringing and pointer with gang closed shown with solid lines. Dashed line pointer positions (1400 KC and 900 KC) shown when tuning condenser is tuned to generator signal.

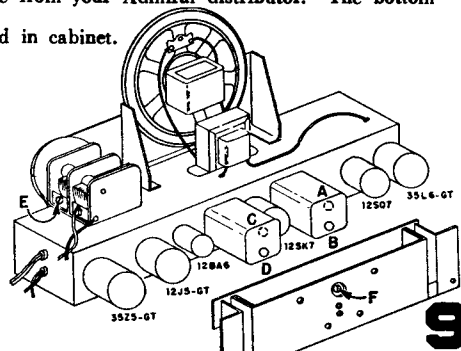
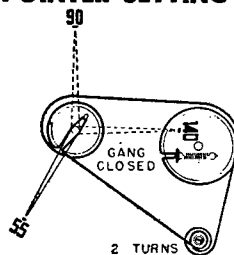

MANUAL OF 1951 RADIO DIAGRAMS

ARVIN RADIOS, MODELS 450T AND 451T
CHASSIS RE-281, 5 TUBE AC-DC

FREQUENCY RANGE

Broadcast 540-1600 kc
IF 455 kc

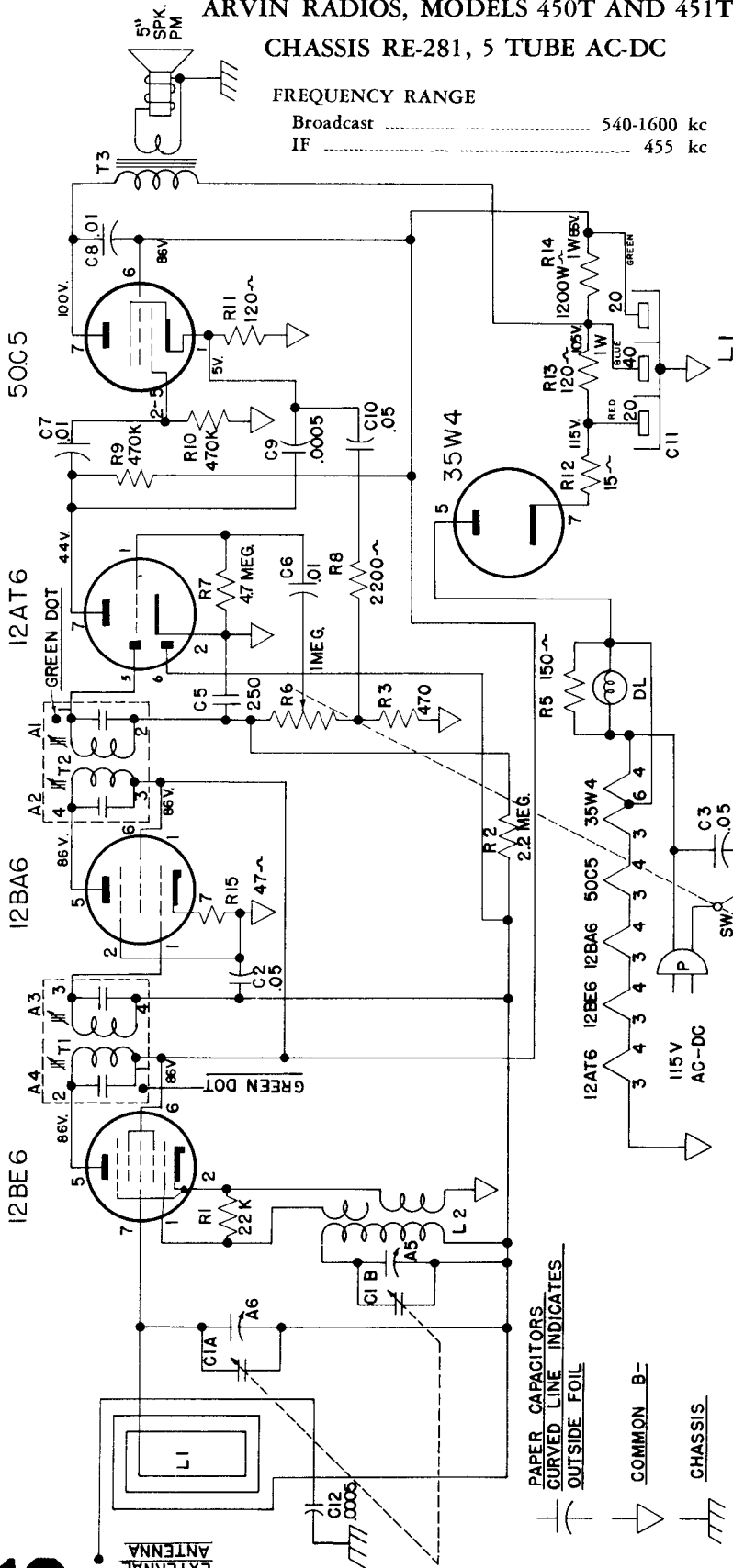

PAPER CAPACITORS
CURVED LINE INDICATES
OUTSIDE FOIL

COMMON B-

CHASSIS

LOCATION OF TUBES AND TRIMMERS

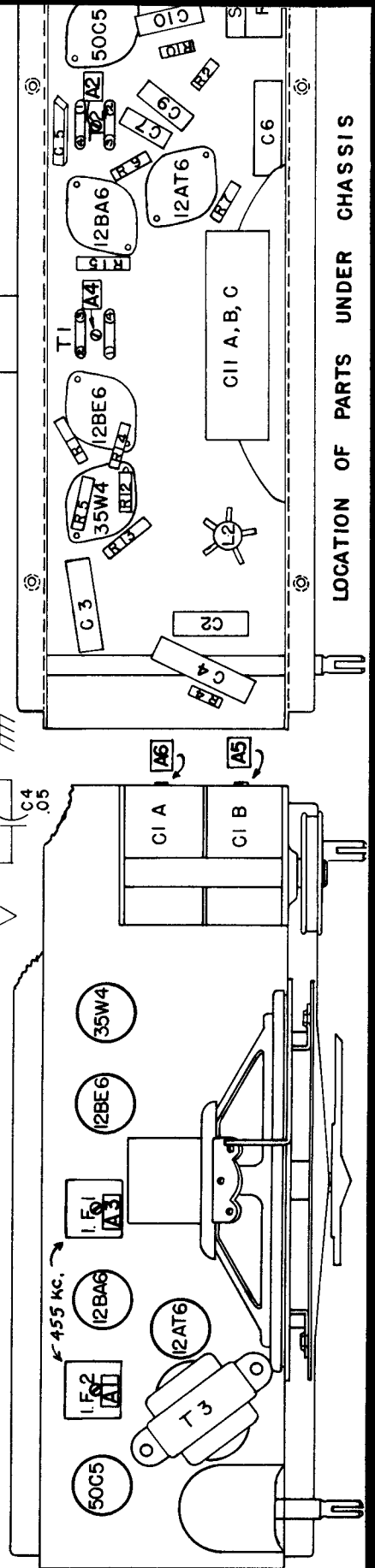

LOCATION OF PARTS UNDER CHASSIS

MANUAL OF 1951 MOST-OFTEN-NEEDED RADIO DIAGRAMS

ARVIN RADIO

ARVIN RADIO, MODEL 446P; CHASSIS-RE-280
4 TUBE BATTERY PORTABLE



FREQUENCY RANGE

Broadcast 540-1600 kc
IF 455 kc

POWER SUPPLY

1 67½ V. B. Battery, Eveready Minimax, No. 467 or Equal.
2 1½ V. D. Size Flashlight Cells, Connected in Parallel.

POWER OUTPUT

Undistorted06 Watts
Maximum15 Watts
Plate Load 10,000 Ohms

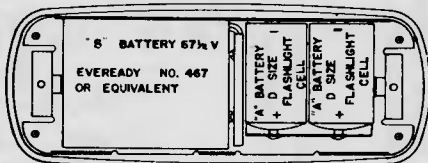
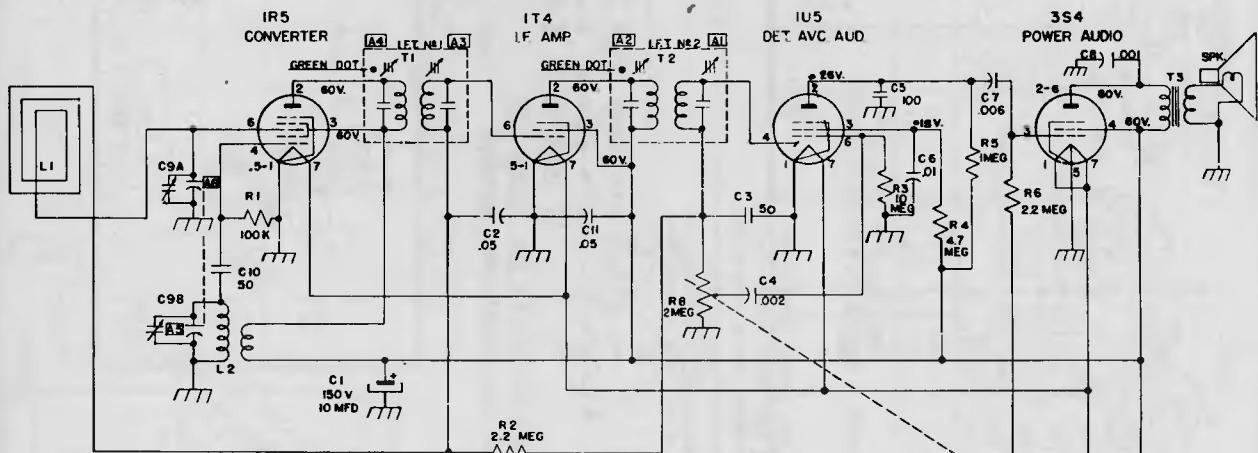

BATTERY INSTALLATION

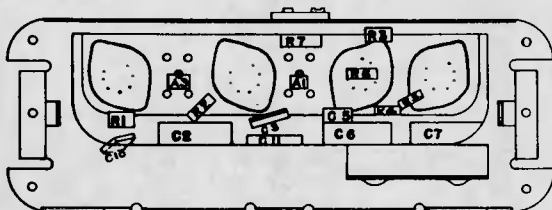

LOCATIONS OF PARTS UNDER CHASSIS

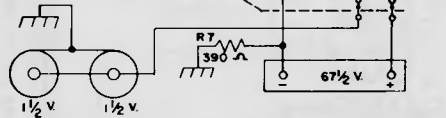

• MEASURED WITH VACUUM TUBE VOLTMETER

VOLUME CONTROL

ON-OFF SWITCH

TUNING

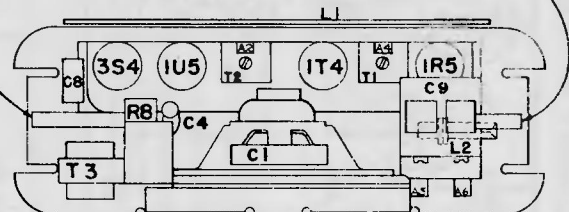

TUBE LAYOUT

ALIGNMENT DATA

Preliminary

Output meter reading to indicate .05 watt across voice coil 0.4 V.
Generator ground lead connected to metal chassis.
Generator modulation 30%, 400 cycles.
Position of Volume control fully on.

Position of Variable	Generator Frequency	Dummy Antenna	Generator Connections	Adjust Trimmers (in order shown)	Trimmer Function
Open	455 KC	.05 MFD	Mixer Grid	A1, A2, A3, A4	I.F.
Open	1650 KC		Test Loop	A5	Osc.
1400 KC	1400 KC		Test Loop	A6	Ant.
600 KC	600 KC		Test Loop	Check Point	

MANUAL OF 1951 RADIO DIAGRAMS

ARVIN RADIOS, MODELS 460T AND 461T
CHASSIS RE-284, 6 TUBE AC-DC

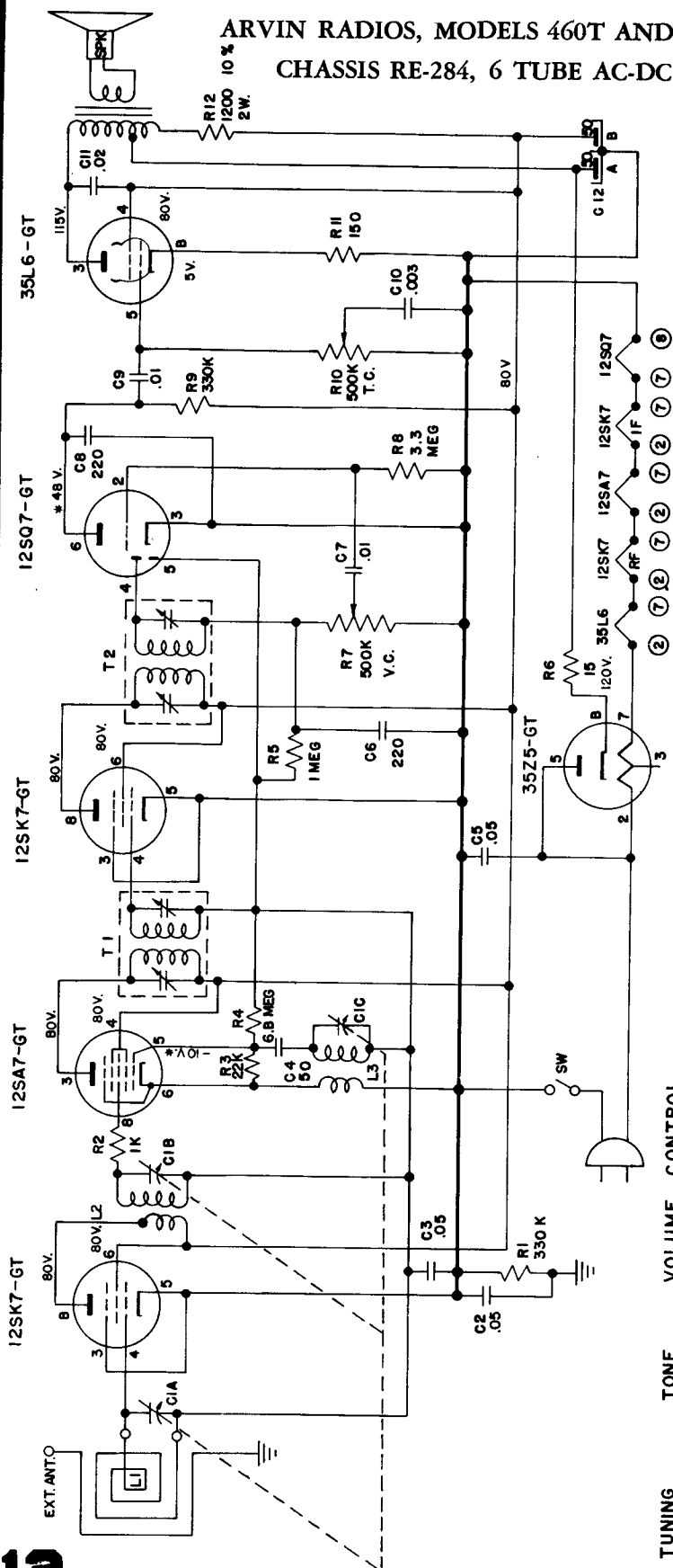

VOLTAGE READINGS TAKEN WITH 117V. A.C. LINE VOLTAGE
*THESE READINGS TAKEN WITH VACUUM TUBE VOLTMETER

TUNING
TONE
DIAL LIGHT
VOLUME CONTROL & SWITCH

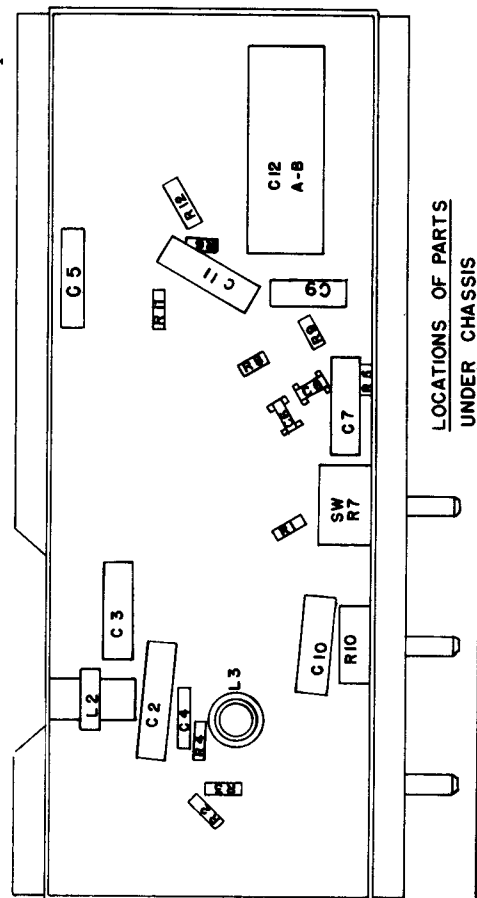

LOCATIONS OF PARTS
UNDER CHASSIS

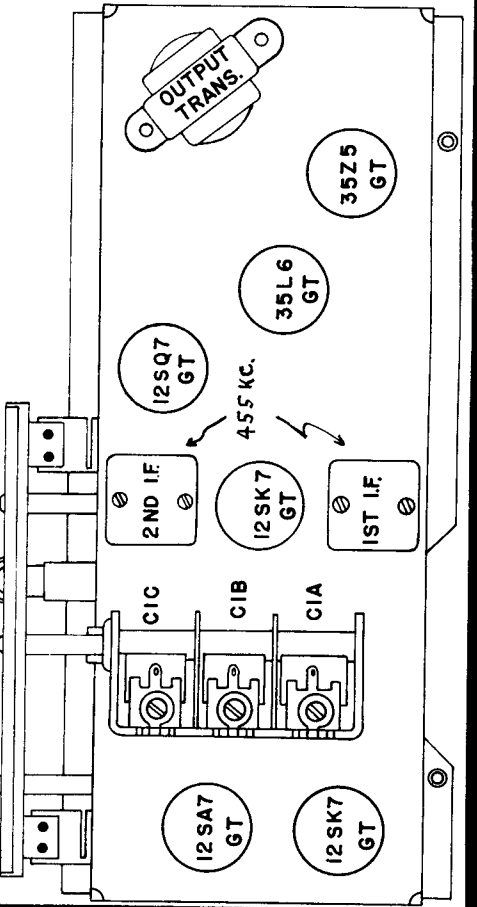

MANUAL OF 1951 MOST-OFTEN-NEEDED RADIO DIAGRAMS

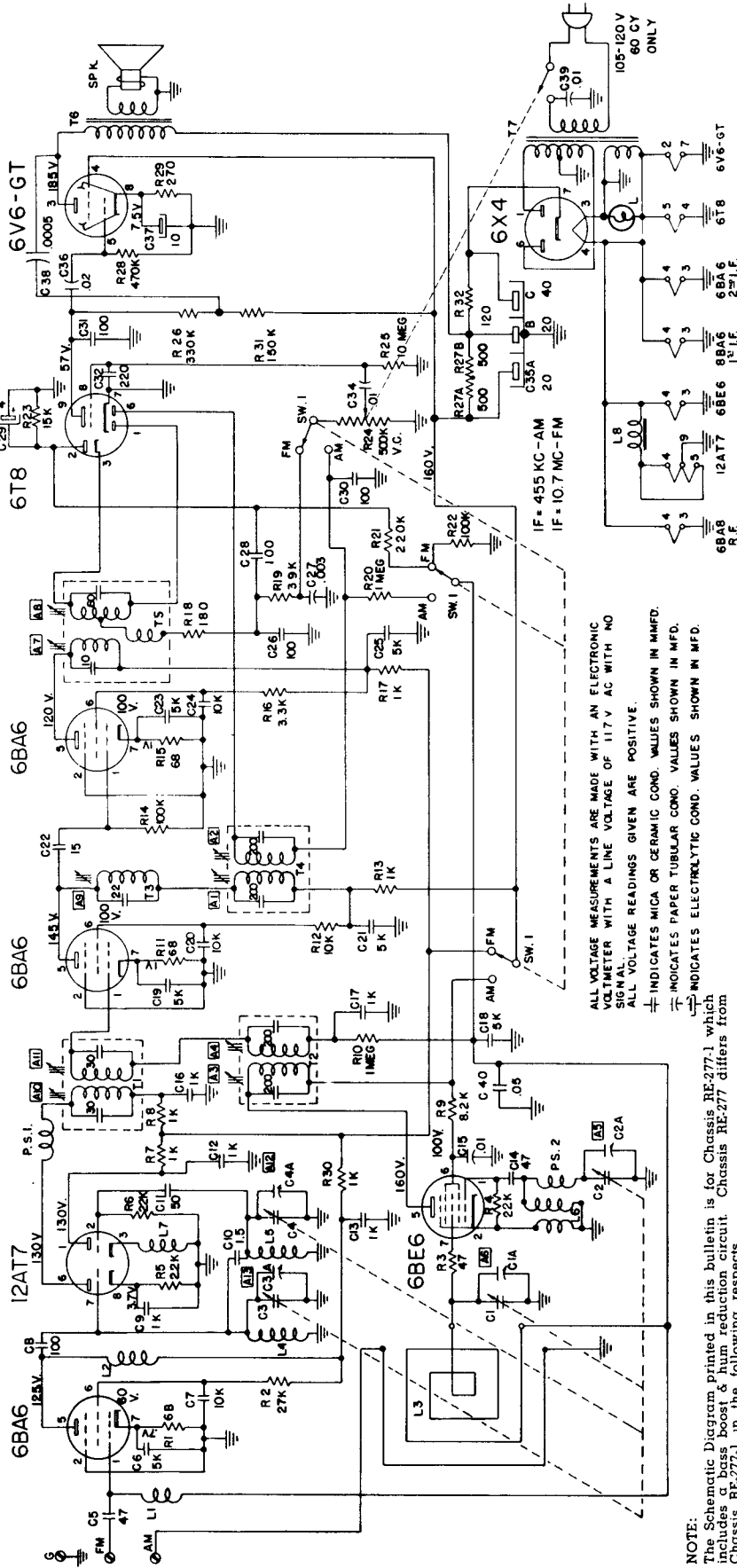

NOTE:
 The Schematic Diagram printed in this bulletin is for Chassis RE-277-1 which includes a bass boost & hum reduction circuit. Chassis RE-277 differs from Chassis RE-277-1 in the following respects.

1. C38 was .02 uf. 400 V., and was connected from plate to screen of the 6V6GT tube.
 2. R31, 150 K ohm 1/4 watt Resistor, was not included in the circuit and R26 connected directly to B+ 140 V.
 3. R32, 120 ohm 1 watt resistor, was not included in the circuit and C35B electrolytic condenser section connected to the center tap of R27.
- The two chassis are identified by the proper RE numbers on the Model Number label on the bottom of the cabinet.

ALL VOLTAGE MEASUREMENTS ARE MADE WITH AN ELECTRONIC VOLTMETER WITH A LINE VOLTAGE OF 117 V AC WITH NO SIGNAL.
 ALL VOLTAGE READINGS GIVEN ARE POSITIVE.
 ⊕ INDICATES MICA OR CERAMIC COND. VALUES SHOWN IN MFD.
 ⊚ INDICATES PAPER TUBULAR COND. VALUES SHOWN IN MFD.
 ⊚ INDICATES ELECTROLYTIC COND. VALUES SHOWN IN MFD.

ARVIN RADIO

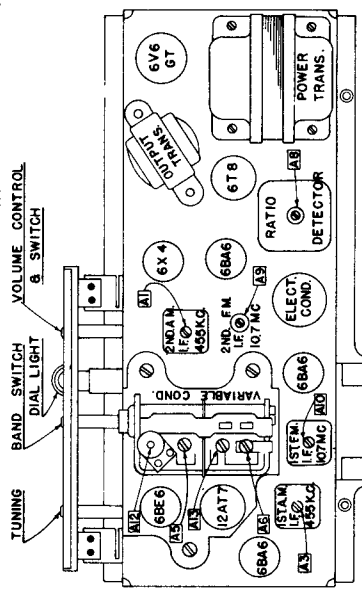

ARVIN RADIOS, MODELS 480TFM AND 481TFM
 CHASSIS RE-277 & RE-277-1, 8 TUBE AC, AM-FM

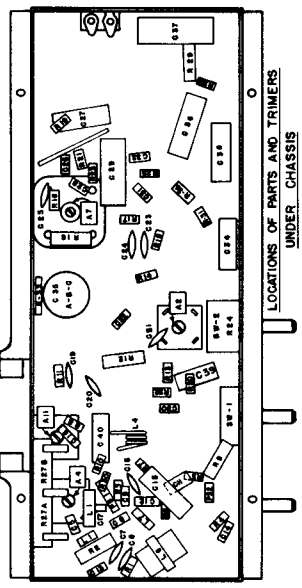

MANUAL OF 1951 MOST-OFTEN-NEEDED RADIO DIAGRAMS

BENDIX RADIO MODELS 951 and 951W

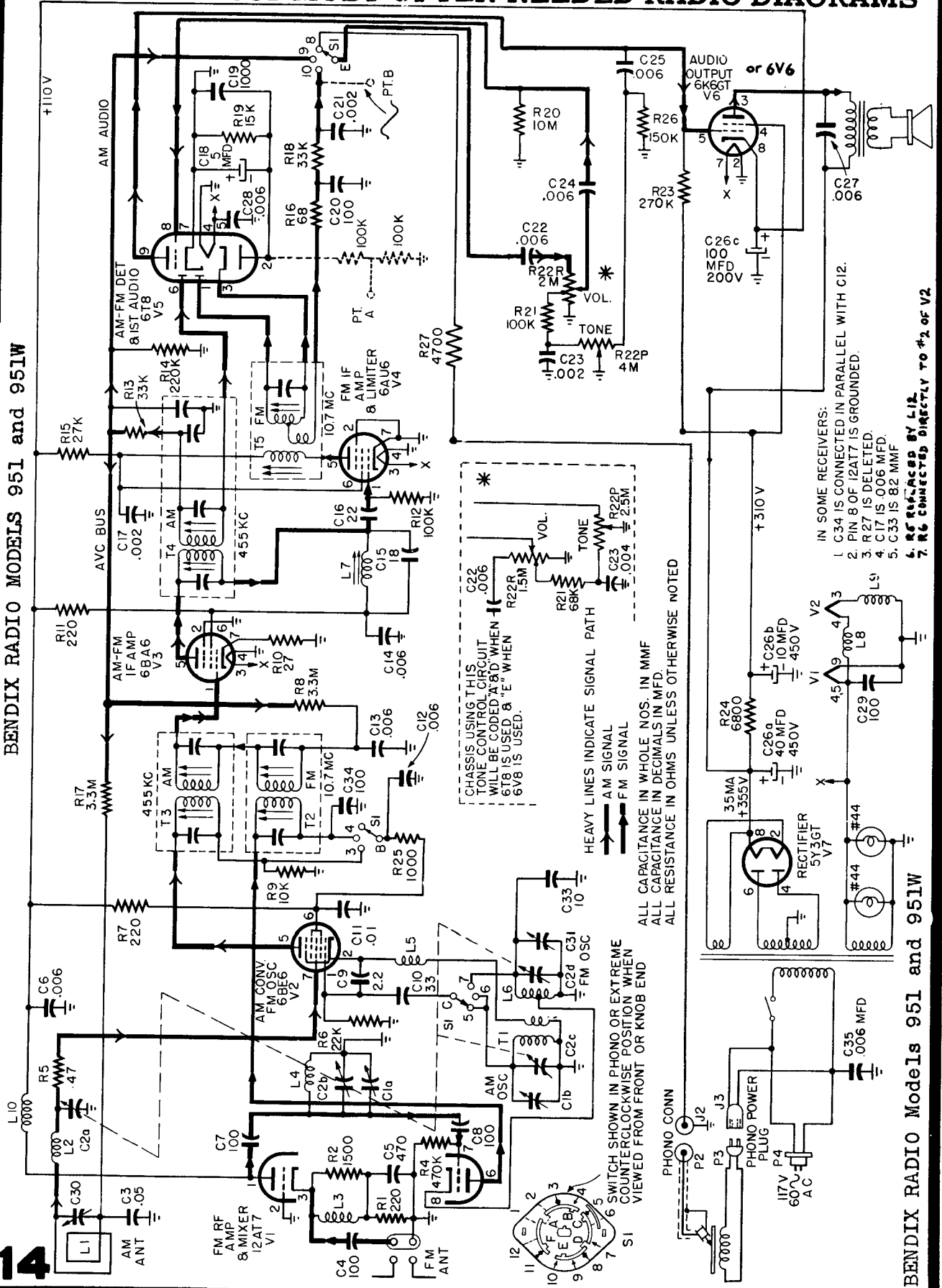

MANUAL OF 1951 MOST-OFTEN-NEEDED RADIO DIAGRAMS

CLOCK - RADIO

Caphart

MODEL
TC-20

RADIO CHASSIS
C-297

V101
12BE6
OSC.-CONV.

V102
12BA6
I-F AMP.

V103
12AV6
DET AVC - 1ST AUDIO

V104
50C5
OUTPUT

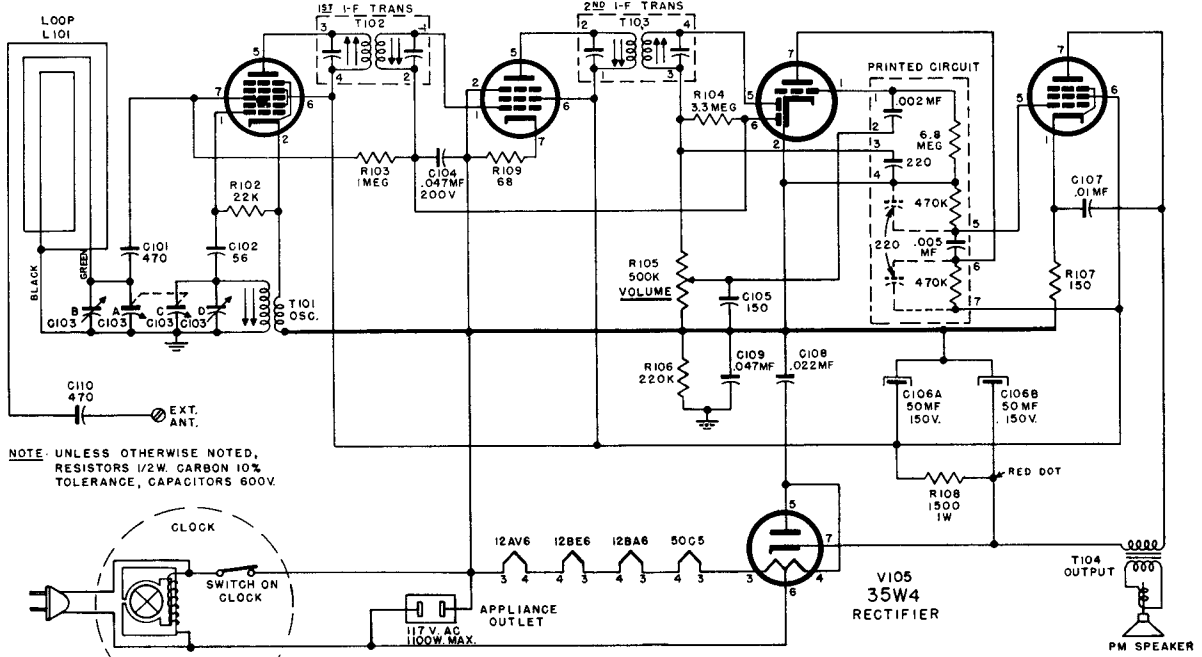

NOTE: UNLESS OTHERWISE NOTED, RESISTORS 1/2W. CARBON 10% TOLERANCE, CAPACITORS 600V.

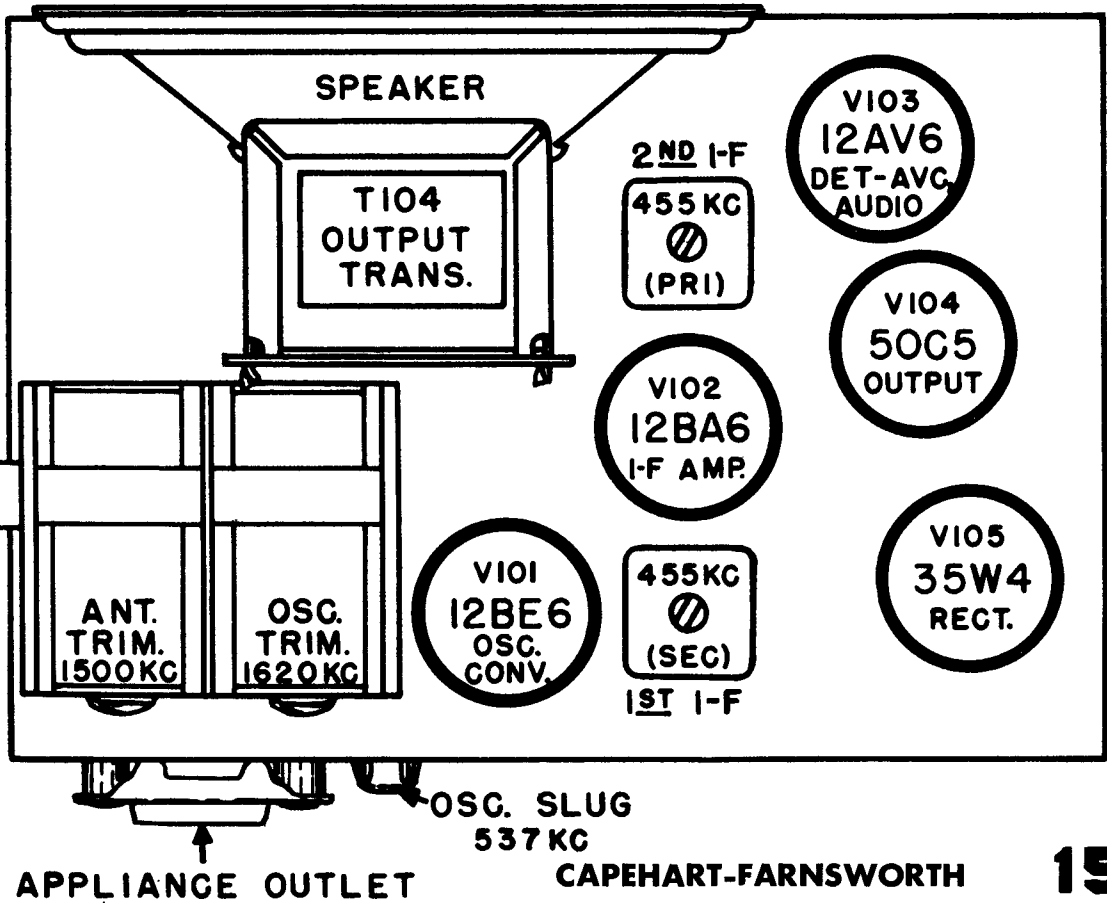
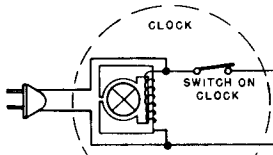

APPLIANCE OUTLET

CAPEHART-FARNSWORTH

MANUAL OF 1951 MOST-OFTEN-NEEDED RADIO DIAGRAMS

THE CAPEHART T-30 MODEL RADIO

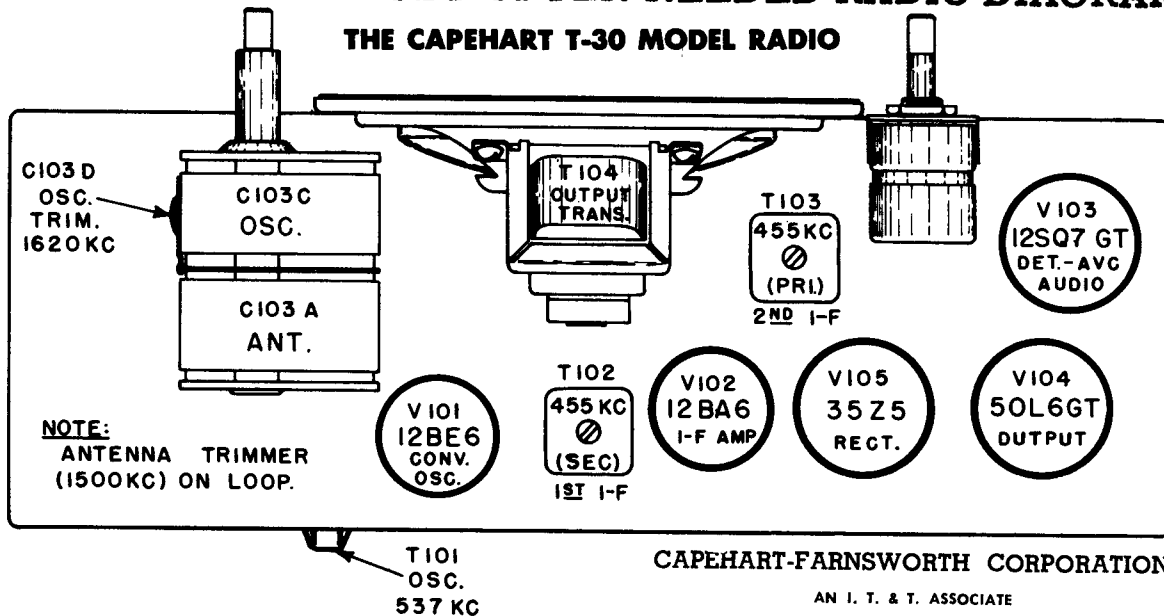

Step	Set RF Generator at	Set Condenser gang at	Adjust	To Obtain
1	455KC	Fully Open at some quiet point	IF Slugs T103 T102	Maximum Output
2	1620KC	1620KC	Osc. Trimmer C103D	Same
3	1500	1500	Ant. Trimmer C103B (on Loop)	Same
4	537KC	537KC	T101 Osc. Slug	Same

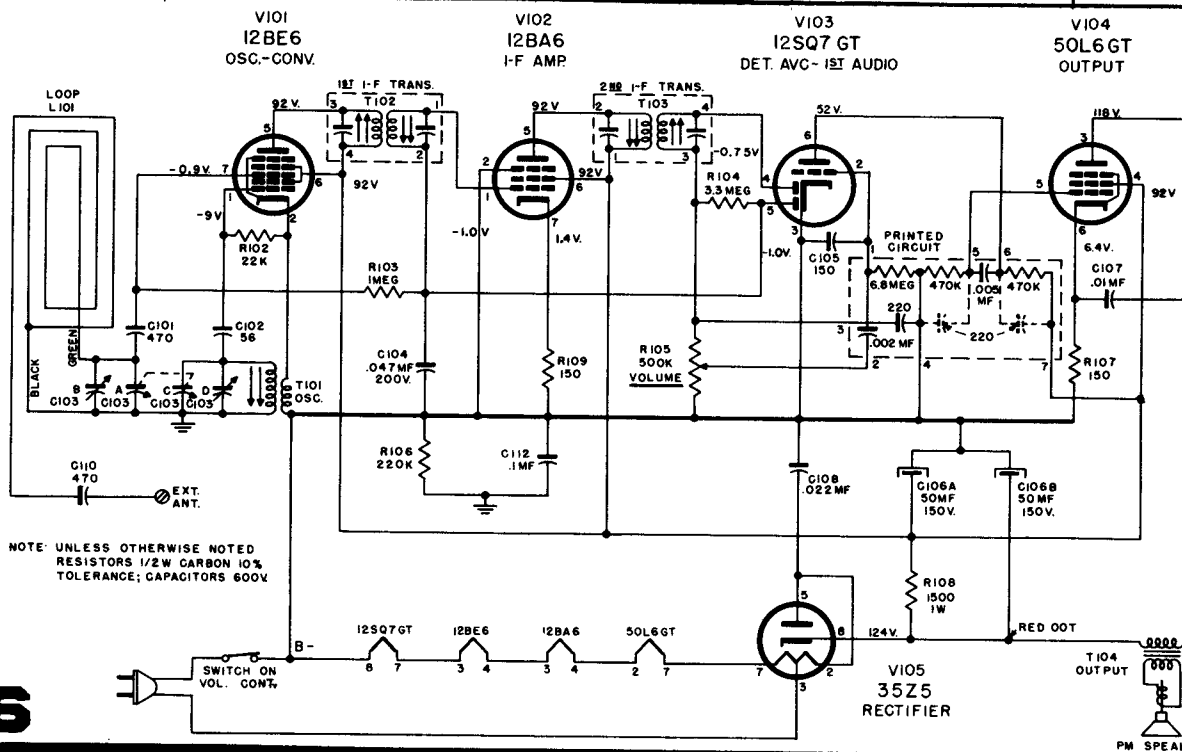

MANUAL OF 1951 MOST-OFTEN-NEEDED RADIO DIAGRAMS

CROSLEY

REVISED MODELS: 11-100U, 11-101U, 11-102U, 11-103U
11-104U, 11-105U

(Chassis 330)

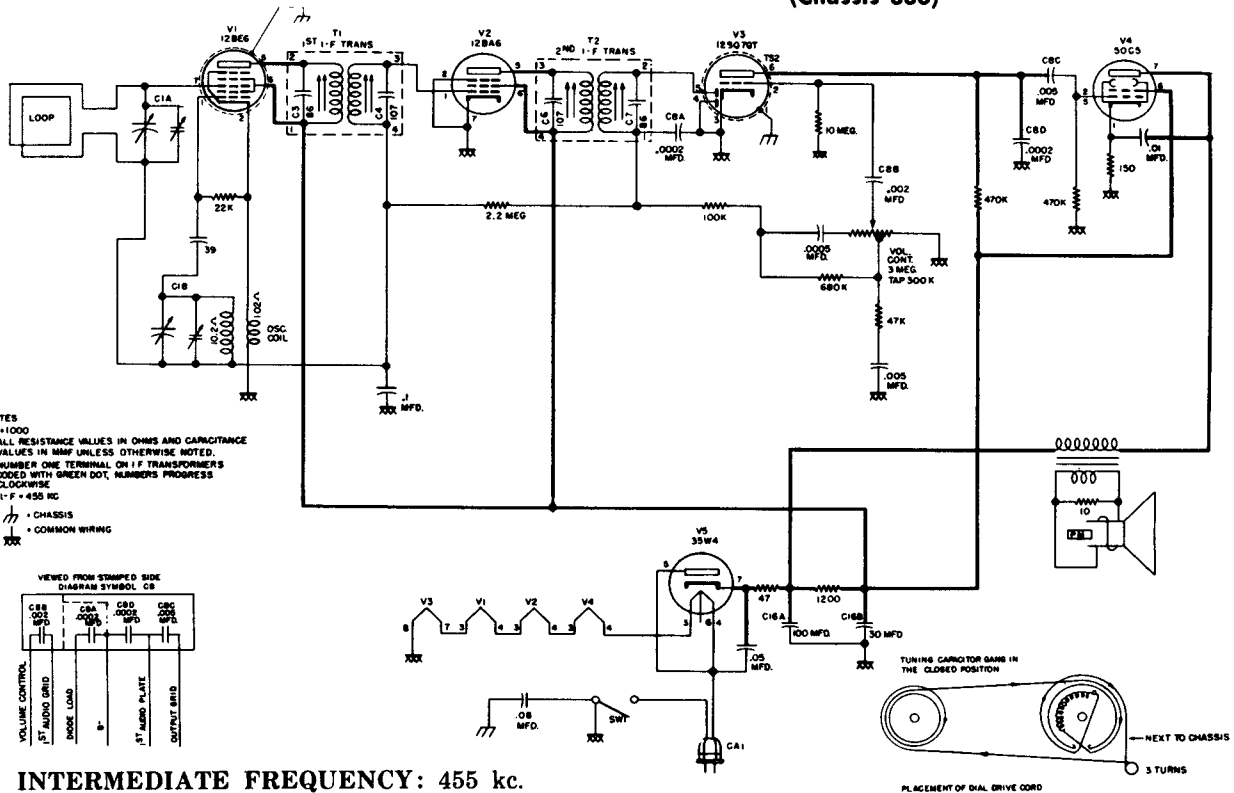

- NOTES
- 1 K=1000
 - 2 ALL RESISTANCE VALUES IN OHMS AND CAPACITANCE VALUES IN MMF UNLESS OTHERWISE NOTED.
 - 3 NUMBER ONE TERMINAL ON I-F TRANSFORMERS CODED WITH GREEN DOT, NUMBERS PROGRESS CLOCKWISE
 - 4 I-F = 455 KC
 - 5 CHASSIS
 - XXX COMMON WIRING

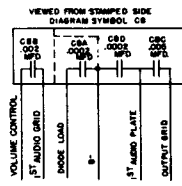

INTERMEDIATE FREQUENCY: 455 kc.

Models D1OBE, D1OCE, D1OEN, D1ORD, D1OTN, and D1OWE, using Chassis 10D, are very similar in circuit to the description on this page. Some of these models used Chassis 10D-1 also where an electromagnetic speaker is employed -- see insert schematic at bottom of page.

The above listed models also used Chassis 301 which is similar to Chassis 330, but uses 12AV6 instead of 12SQ7 as V3. In some sets R2 is a 3.3 megohms and C5 is .05 mfd.

CONVERTER

AT 540 KC.

I-F AMPLIFIER

RECTIFIER

OUTPUT

NOTES.

1. BOTTOM VIEW OF TUBE SOCKETS.
2. MEASURE VOLTAGE WITH AN ELECTRONIC VOLTMEETER FROM SOCKET LUG TO B - PIN 2 ON THE 12BA6.
3. LINE VOLTAGE 117 V. 60~
4. NC = NO CONNECTION.
5. # = AC VOLTAGE
6. SOCKET VOLTAGE TOLERANCE ± 10%.

RECTIFIER & E.M. SPEAKER SCHEMATIC
10D-1 CHASSIS

OET-AVC.-1ST AUDIO AMPL.

MANUAL OF 1951 MOST-OFTEN-NEEDED RADIO DIAGRAMS

CROSLEY

MODELS 11-114U, 11-115U, 11-116U,
11-117U, 11-118U, 11-119U

** (Chassis 330, 330-1)

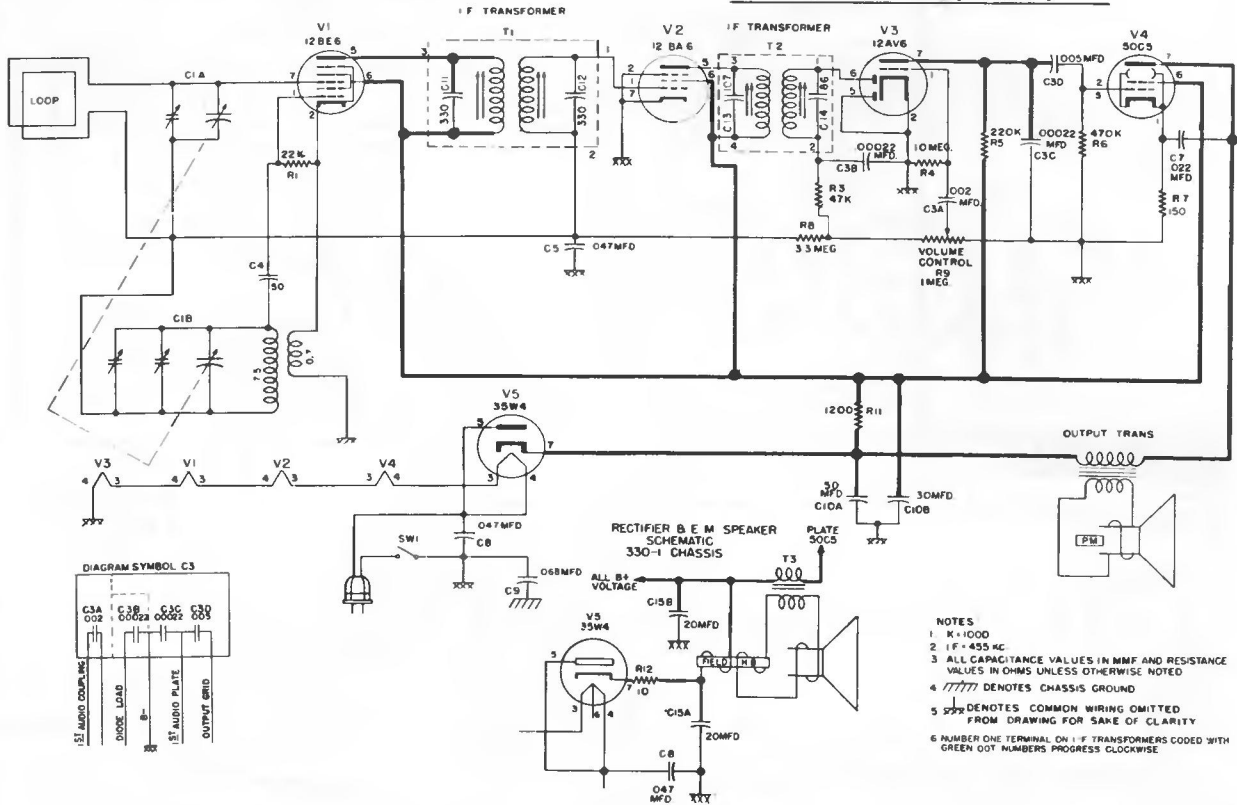

SCHEMATIC DIAGRAM: CHASSIS 330, 330-1 (Early Production Sets)

** Chassis 330 is equipped with a P. M. Speaker Chassis 330-1 is equipped with an E. M. Speaker

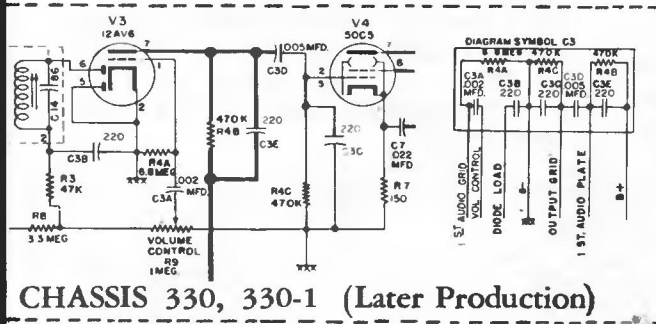

CHASSIS, TOP VIEW

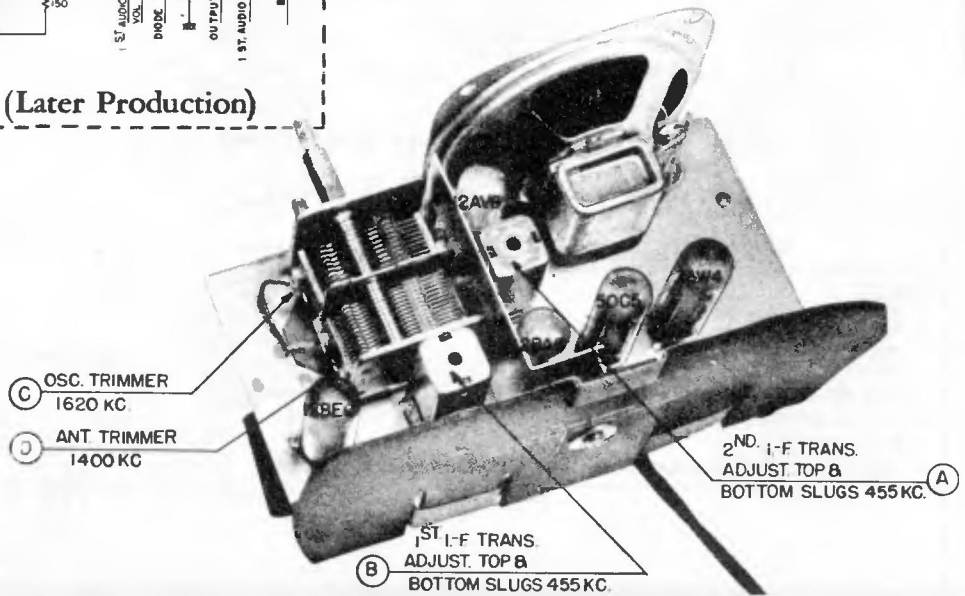

MANUAL OF 1951 MOST-OFTEN-NEEDED RADIO DIAGRAMS

CROSLLEY

MODELS: 11-106U, 11-107U, 11-108U, 11-109U
(Chassis 302)

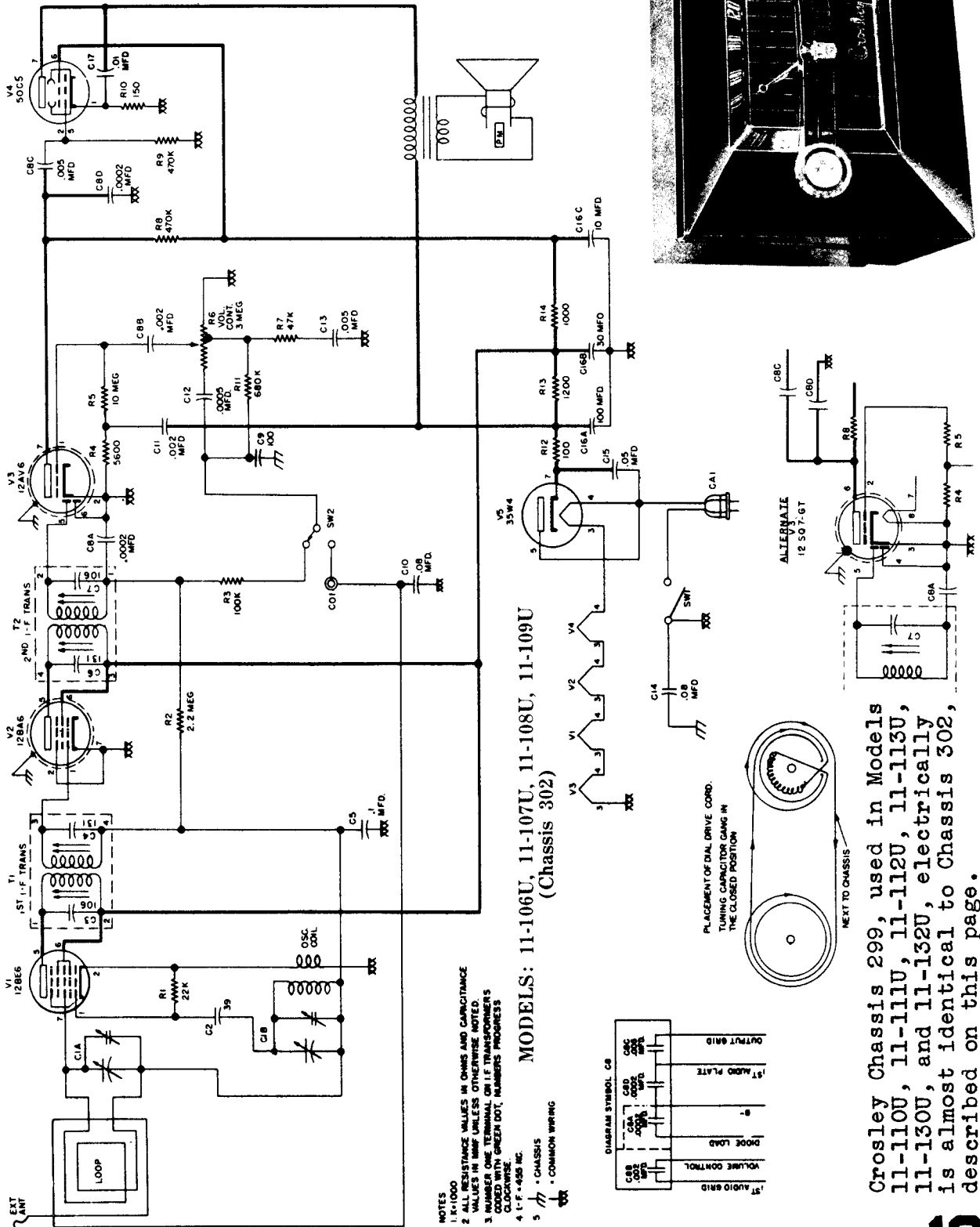
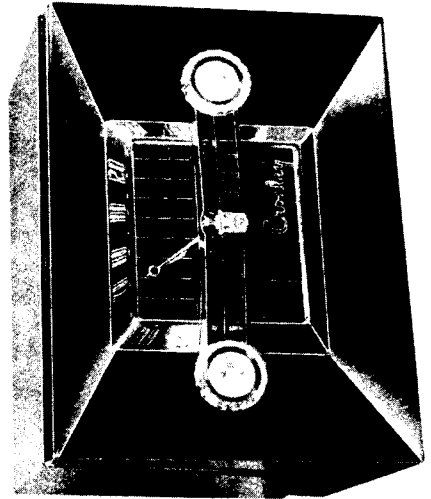

MODELS: 11-106U, 11-107U, 11-108U, 11-109U
(Chassis 302)

- NOTES
 1. K=1000
 2. ALL RESISTANCE VALUES IN OHMS AND CAPACITANCE VALUES IN MMF UNLESS OTHERWISE NOTED.
 3. NUMBER ONE TERMINAL ON IF TRANSFORMER COILS WITH GREEN DOT, NUMBERS PROGRESSIVE
 4. 1-F=465 MC.
 5. CHASSIS
 * COMMON WIRING

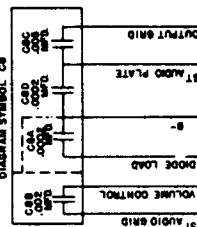

PLACEMENT OF DIAL DRIVE CORD. TUNING CAPACITOR GANG IN THE CLOSED POSITION

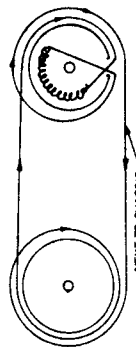

Crosley Chassis 299, used in Models 11-110U, 11-111U, 11-112U, 11-113U, 11-130U, and 11-132U, electrically is almost identical to Chassis 302, described on this page.

MANUAL OF 1951 MOST-OFTEN-NEEDED RADIO DIAGRAMS

CROSLEY

MODELS: 11-126U, 11-127U, 11-128U, 11-129U
(Chassis 312)

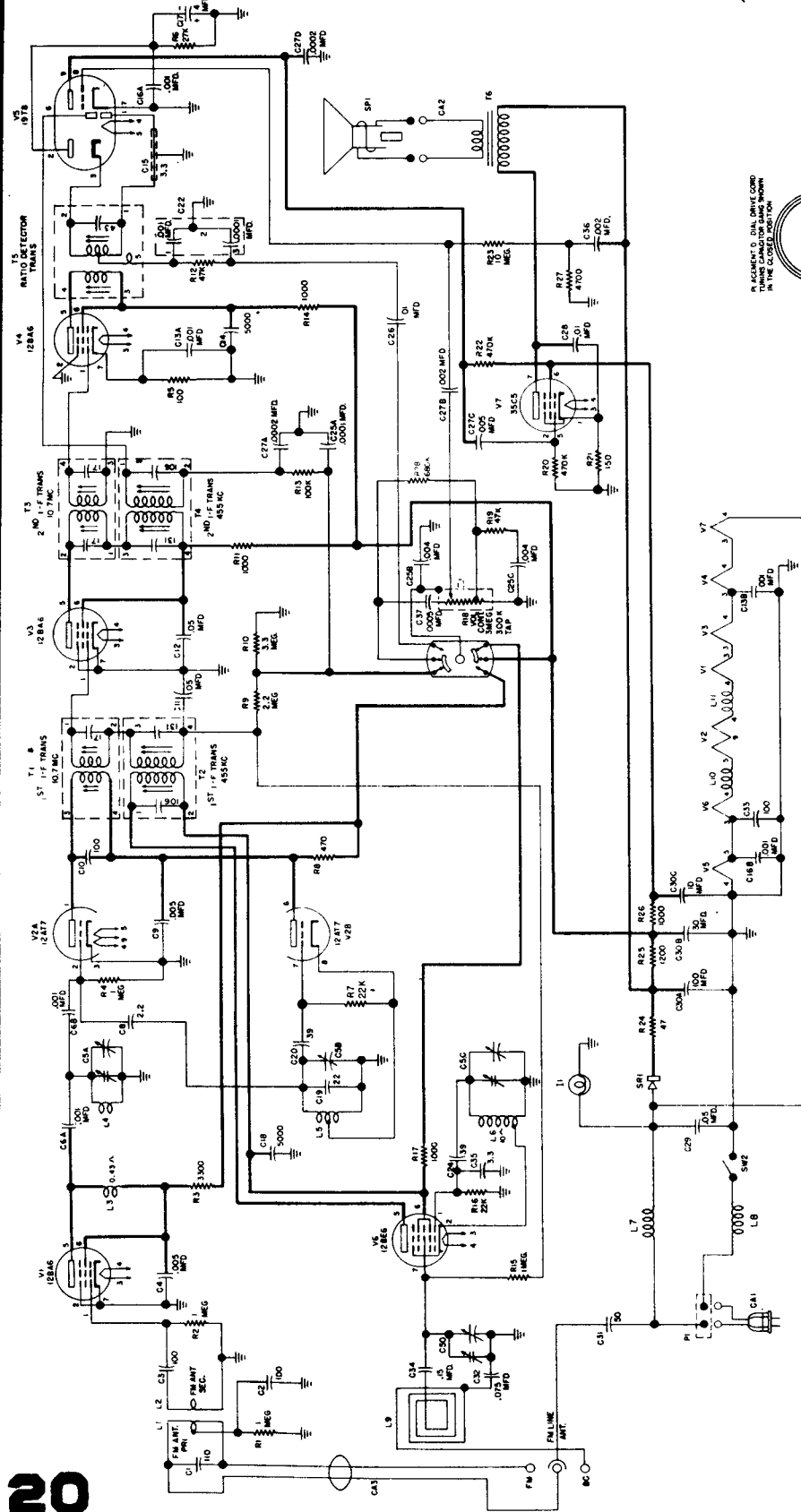

REPLACE ONLY ONE OR TWO TUBES CAN NOT BE SHOWN IN THE CLOSED POSITION

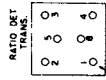
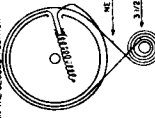

NOTES:
1. K-1000
2. 1.4-105 KC. FM
3. ALL CAPACITANCE VALUES IN MFD UNLESS OTHERWISE SPECIFIED
4. COUNTER CLOCKWISE POSITION
5. NUMBER 1 TERMINAL ON I.F. TRANSFORMERS COODE BY GREEN DOT NUMBERS PROGRESS CLOCKWISE, EXCEPT AS NOTED

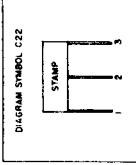
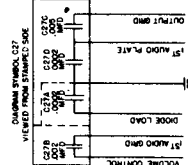
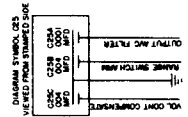

TYPE: Seven-tube, two-band, superheterodyne.
FREQUENCY RANGE: Standard Broadcast Band; 540 to 1620 kc.
 Frequency Modulation Band; 88 to 108 megacycles.
INTERMEDIATE FREQUENCY: Standard Broadcast Band; 455 kc.
 Frequency Modulation Band; 10.7 mc.
FM ANTENNA INPUT IMPEDANCE: 75 ohms balanced.
POWER SUPPLY: a.c.—d.c.

MANUAL OF 1951 MOST-OFTEN-NEEDED RADIO DIAGRAMS

CROSLLEY

MODELS: 11-120U, 11-121U, 11-122U, 11-123U
11-124U, 11-125U

Models: D-25 WE, D-25 TN, D-25 CE,
D-25 MN, D-25 BE, D-25 GN

(Chassis 311, 311-1)

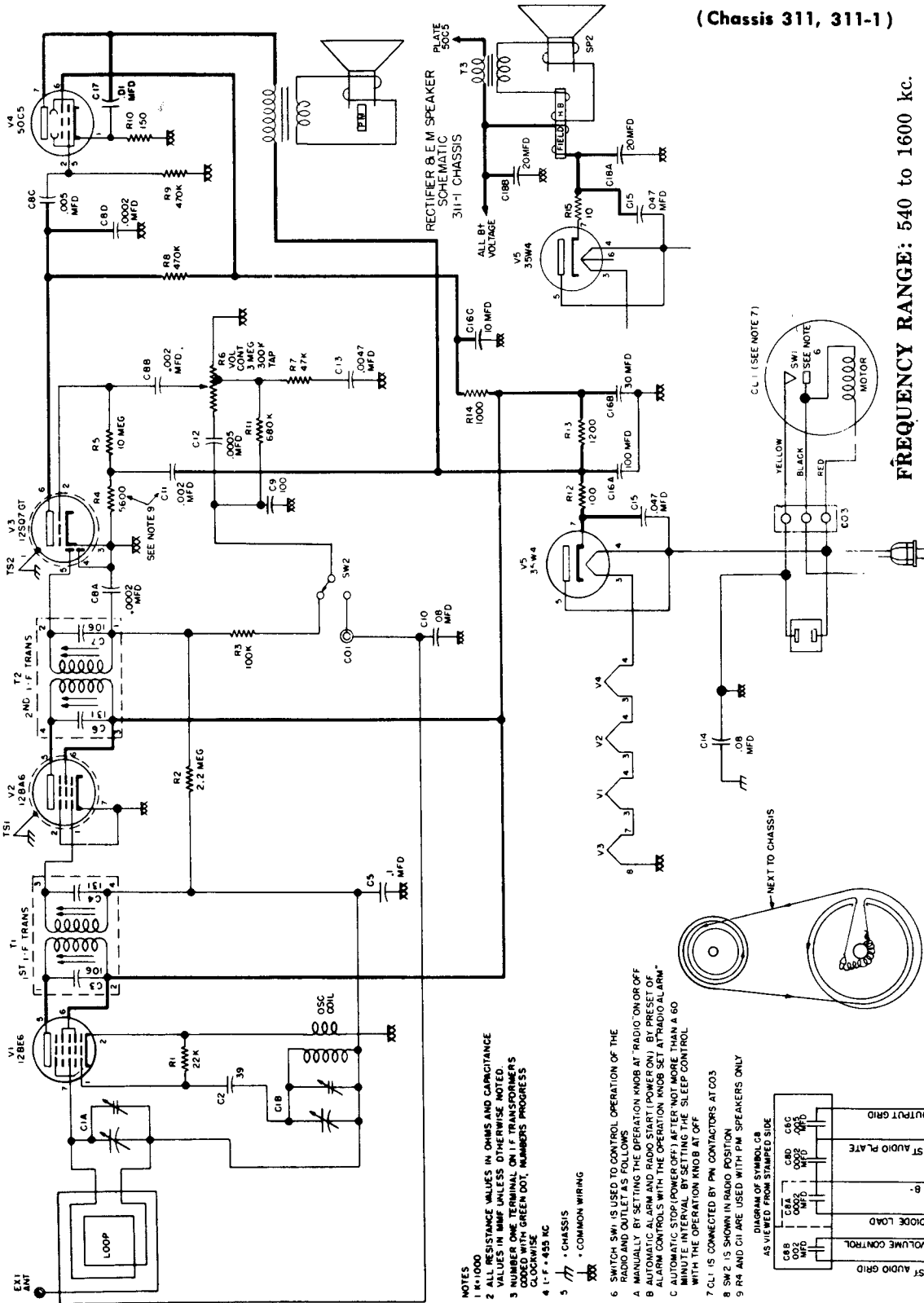

MANUAL OF 1951 MOST-OFTEN-NEEDED RADIO DIAGRAMS

CROSLEY

MODELS 11-301U, 11-302U, 11-303U, 11-304U, 11-305U

(Chassis 303)

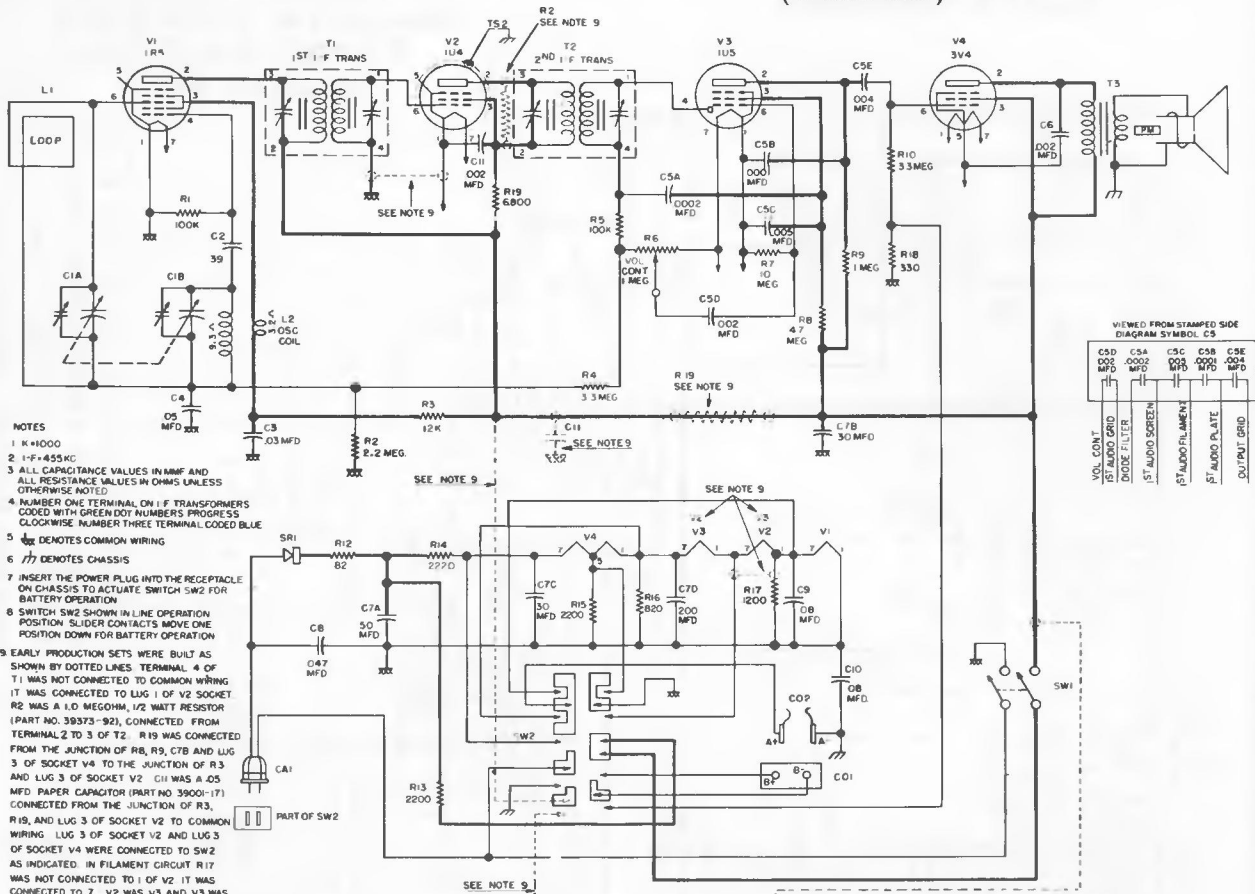

- NOTES**
- 1 K=1000
 - 2 F=455 KC
 - 3 ALL CAPACITANCE VALUES IN MMF AND ALL RESISTANCE VALUES IN OHMS UNLESS OTHERWISE NOTED
 - 4 NUMBER ONE TERMINAL ON I-F TRANSFORMERS CODED WITH GREEN DOT NUMBERS PROGRESS CLOCKWISE, NUMBER THREE TERMINAL CODED BLUE
 - 5 XXX DENOTES COMMON WIRING
 - 6 // DENOTES CHASSIS
 - 7 INSERT THE POWER PLUG INTO THE RECEPTACLE ON CHASSIS TO ACTUATE SWITCH SW2 FOR BATTERY OPERATION
 - 8 SWITCH SW2 SHOWN IN LINE OPERATION POSITION. SLIDER CONTACTS MOVE ONE POSITION DOWN FOR BATTERY OPERATION
 - 9 EARLY PRODUCTION SETS WERE BUILT AS SHOWN BY DOTTED LINES. TERMINAL 4 OF T1 WAS NOT CONNECTED TO COMMON WIRING. IT WAS CONNECTED TO LUG 1 OF V2 SOCKET. R2 WAS A 1.0 MEGOHM, 1/2 WATT RESISTOR (PART NO. 39373-92), CONNECTED FROM TERMINAL 2 TO 3 OF T2. R19 WAS CONNECTED FROM THE JUNCTION OF R8, R9, C7B AND LUG 3 OF SOCKET V4 TO THE JUNCTION OF R3 AND LUG 3 OF SOCKET V2. C11 WAS A .05 MFD. PAPER CAPACITOR (PART NO. 39001-17) CONNECTED FROM THE JUNCTION OF R3, R19, AND LUG 3 OF SOCKET V2 TO COMMON WIRING. LUG 3 OF SOCKET V2 AND LUG 3 OF SOCKET V4 WERE CONNECTED TO SW2 AS INDICATED. IN FILAMENT CIRCUIT R17 WAS NOT CONNECTED TO I OF V2. IT WAS CONNECTED TO 7. V2 WAS V5 AND V3 WAS V2. V1 ALSO HAD A SHIELD (PART NO. W-44784), THE SAME AS V2. REVISING AN EARLY PRODUCTION SET TO A LATER PRODUCTION SET, AS SHOWN BY THE SOLID LINES IN SCHEMATIC WIRING DIAGRAM, IMPROVES ITS SENSITIVITY AND STABILITY.

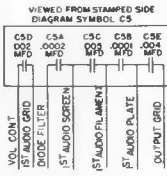

INTERMEDIATE FREQUENCY: 455 kc.

BOTTOM VIEW OF TUBE SOCKETS
VOLTAGES MEASURED WITH AN ELECTRONIC VOLTMETER FROM SOCKET LUG TO (B-)
W J = WIRING JUNCTION
N C = NO CONNECTION
▲ = VOLTAGES MEASURED WITH RADIO PLUGGED INTO 117 V 60 CYCLE LINE.
ALL OTHER VOLTAGES MEASURED IN BATTERY POSITION WITH "A" = 1.45 VOLTS, "B" = 67 1/2 VOLTS

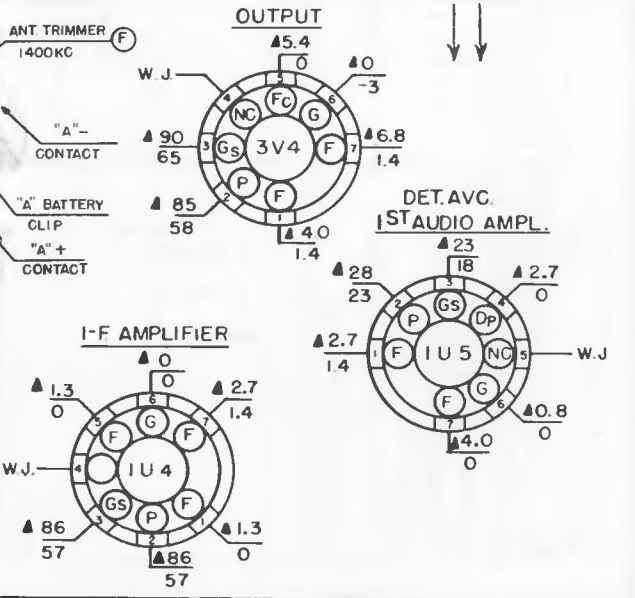
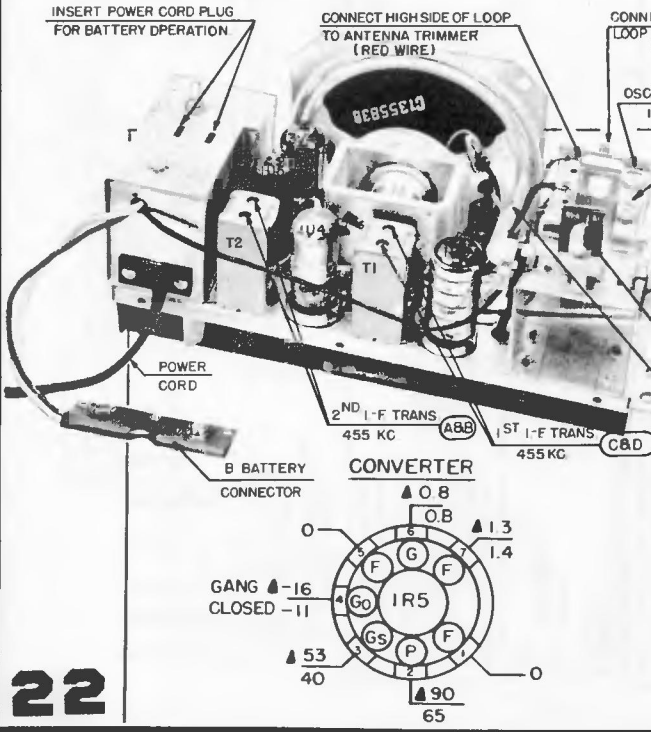

MANUAL OF 1951 MOST-OFTEN-NEEDED RADIO DIAGRAMS

CROSLLEY

RADIO CHASSIS 332—PHONO UNIT V-950
USED IN MODELS 11-444MU, 11-474BU

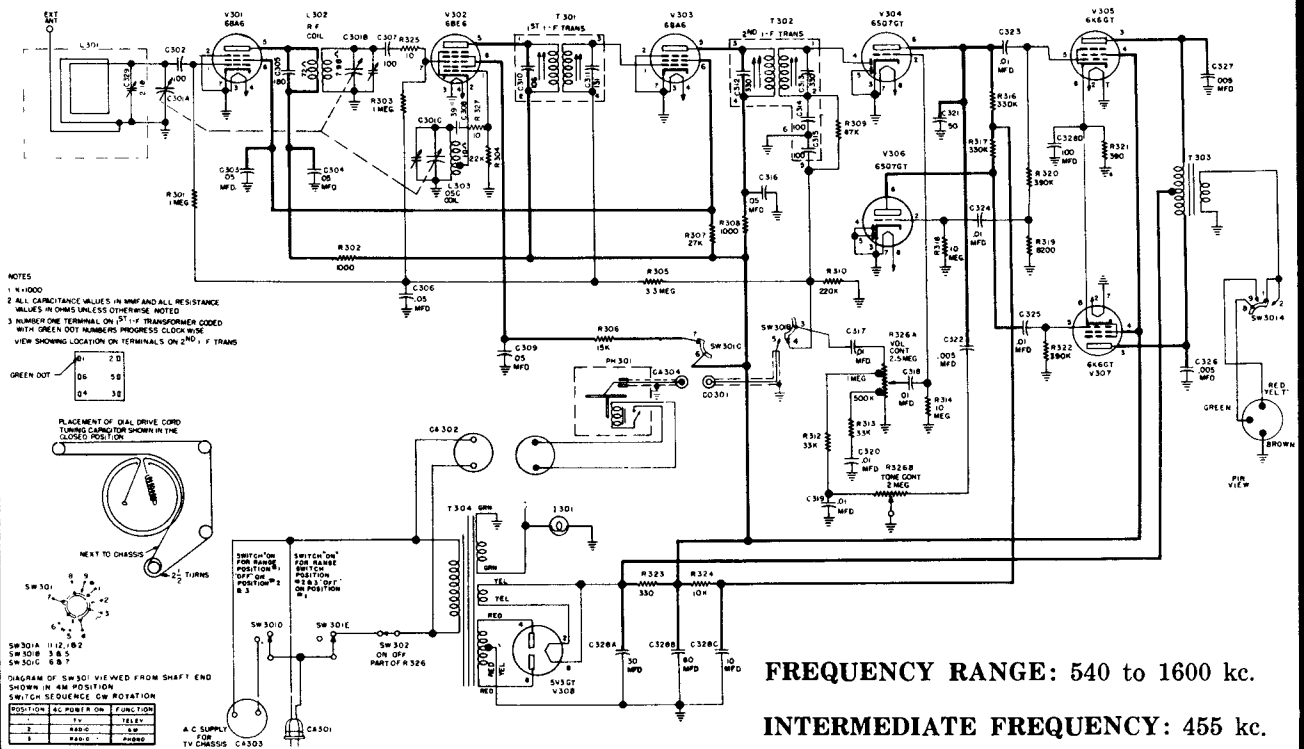

FREQUENCY RANGE: 540 to 1600 kc.
INTERMEDIATE FREQUENCY: 455 kc.

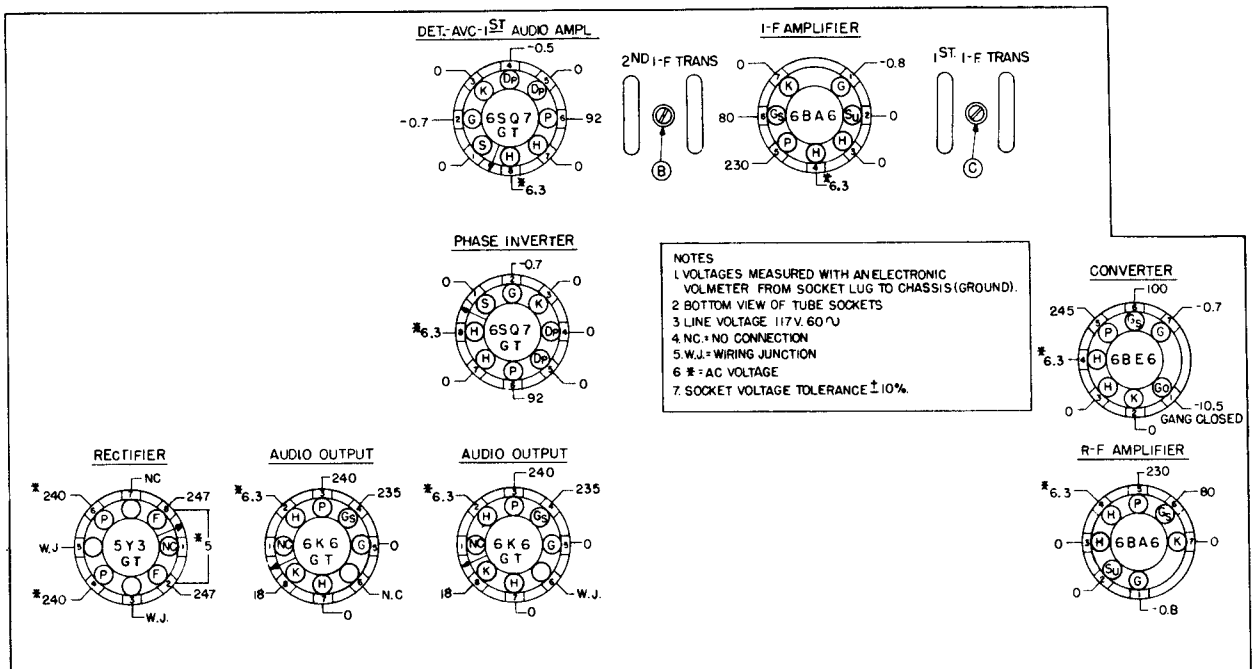

SOCKET VOLTAGE CHART

MANUAL OF 1951 MOST-OFTEN-NEEDED RADIO DIAGRAMS

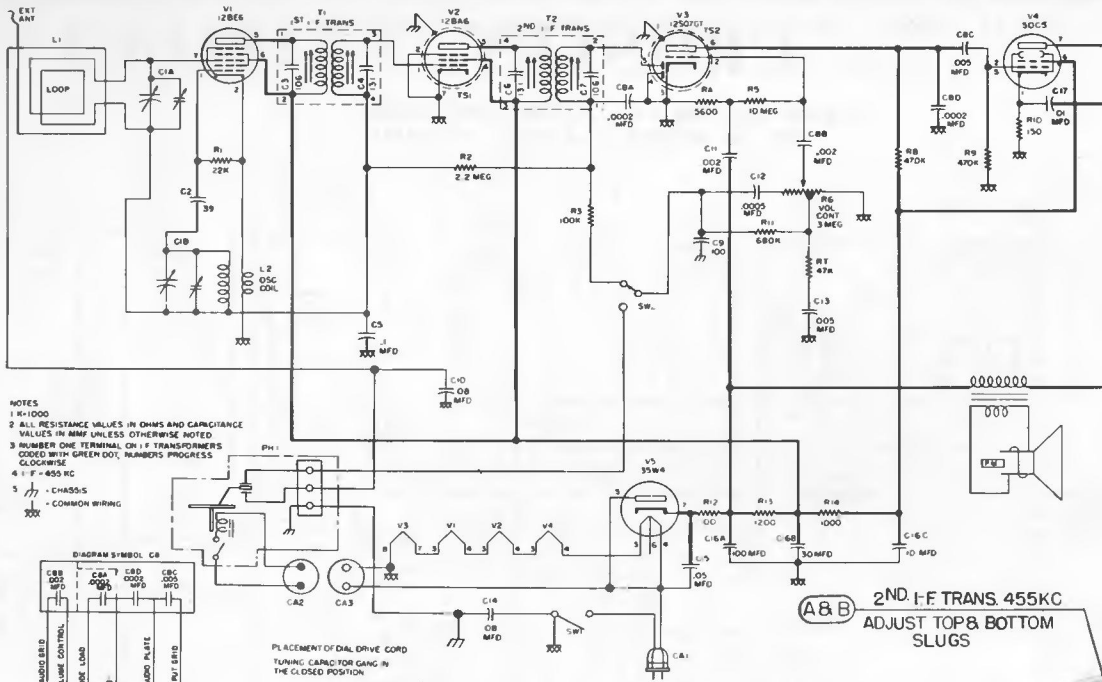

- NOTES
 1 K=1000
 2 ALL RESISTANCE VALUES IN OHMS AND CAPACITANCE VALUES IN MMF UNLESS OTHERWISE NOTED
 3 NUMBER ONE TERMINAL ON I-F TRANSFORMERS CODED WITH GREEN DOT, NUMBERS PROGRESS CLOCKWISE
 4 I-F=455 KC
 5 CHASSIS
 XXX COMMON WIRING

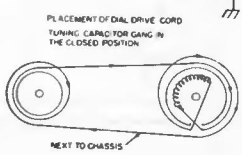
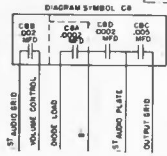

A & B 2ND I-F TRANS. 455 KC
 ADJUST TOP & BOTTOM SLUGS

C & D 1ST I-F TRANS. 455 KC.
 ADJUST TOP & BOTTOM SLUGS.

= CROSLEY =

MODELS: 11-550MU, 11-560BU
 (Chassis 337)

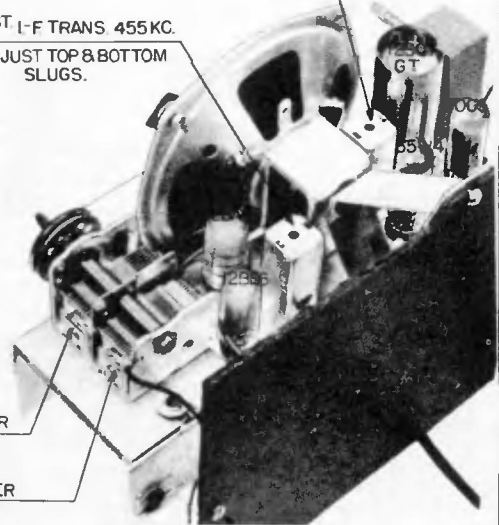

- E OSC. TRIMMER
 1600 KC
 F ANT. TRIMMER
 1400 KC

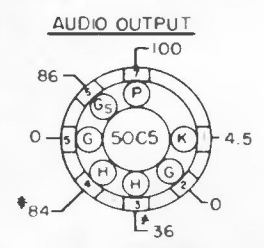
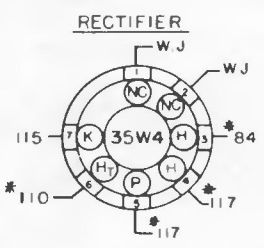
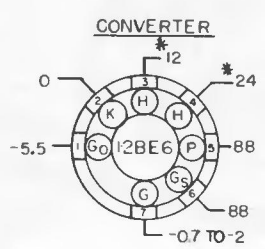

- NOTES
 1 BOTTOM VIEW OF TUBE SOCKETS.
 2 VOLTAGES MEASURED WITH AN ELECTRONIC VOLTMETER FROM SOCKET LUG TO B-(PIN 7 OF 12BA6)
 3 MEASURED WITH THE VOLUME CONTROL AT MINIMUM & NO SIGNAL INTO THE LOOP, TUNING GANG CLOSED.
 4 W.J = WIRING JUNCTION.
 * = AC VOLTAGES NC = NO CONNECTION
 5 LINE VOLTAGE = 117V, 60~AC
 6 SOCKET VOLTAGE TOLERANCE ± 10%

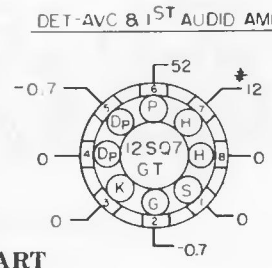
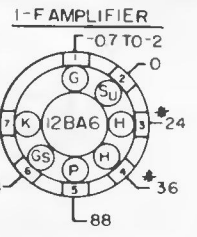

SOCKET VOLTAGE CHART

DeWALD RADIO INSTRUCTION SHEET
MODEL E-520

Alignment instructions for this model given on page 26, over.

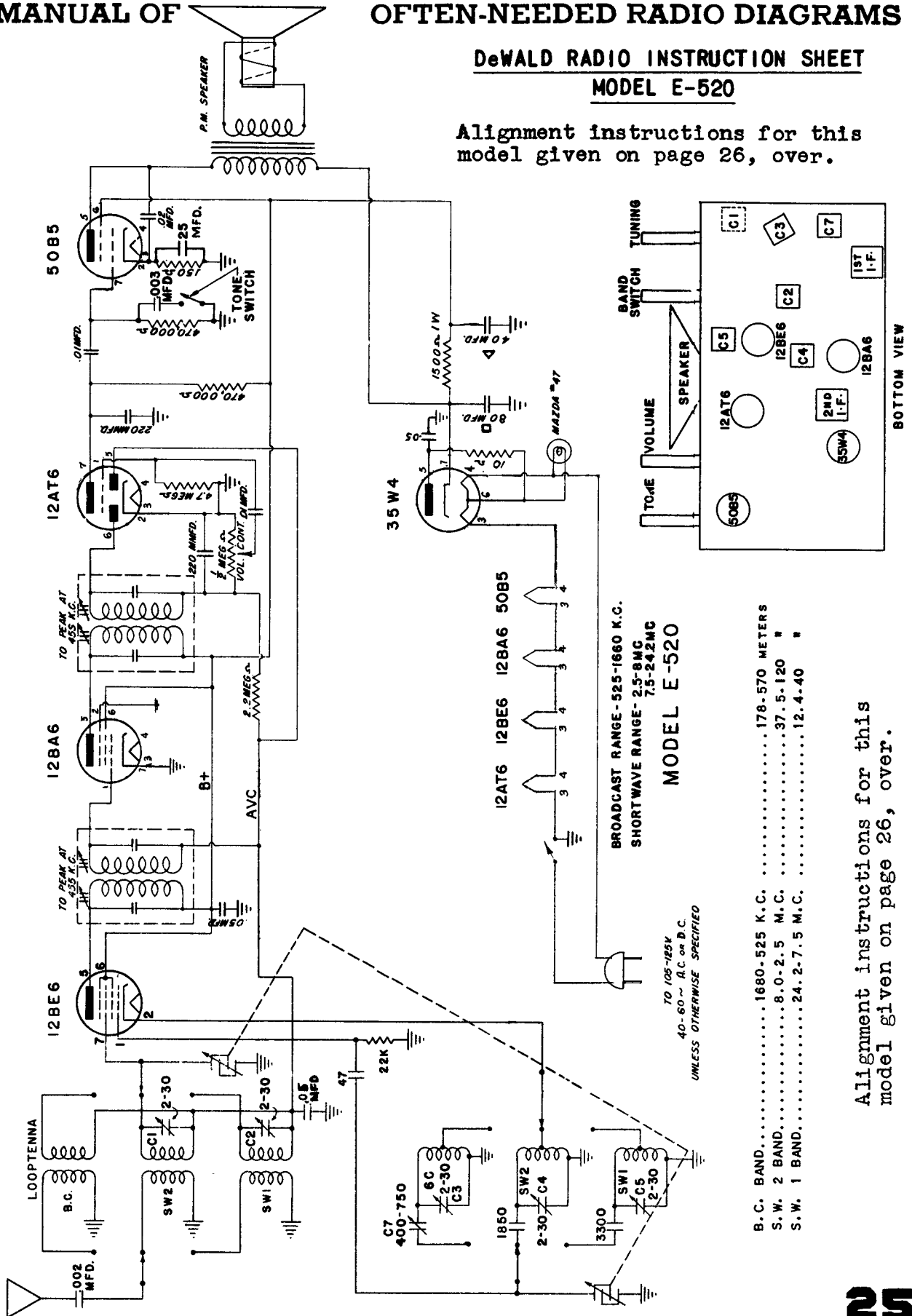

BROADCAST RANGE - 525-1660 K.C.
SHORTWAVE RANGE - 2.5-8MC
7.5-24.2MC
MODEL E-520

B.C. BAND.....	1680-525 K.C.	178-570 METERS
S.W. 2 BAND.....	8.0-2.5 M.C.	37.5-120 "
S.W. 1 BAND.....	24.2-7.5 M.C.	12.4-40 "

TO 105-125V
40-60 ~ A.C. OR D.C.
UNLESS OTHERWISE SPECIFIED

Alignment instructions for this model given on page 26, over.



MANUAL OF 1951 MOST-OFTEN-NEEDED RADIO DIAGRAMS

Alignment Instructions for DeWald Radio Model E-520 (Circuit Diagram on page 25)

To calibrate Model E-520 receiver, connect the output of a signal generator in series with a 200 mmfd. fixed condenser to the flexible antenna lead attached to the loop. Connect the low side of the generator through a 0.1 mfd. condenser to the receiver chassis. The wave band switch should be in the broadcast position. Adjust the generator to 455 KC. and adjust both I.F. transformers (both top and bottom) for maximum signal output. Open the variable condenser for minimum capacity. Turn the wave band switch to short wave #1 position. Set generator at 24.2 MC. Peak the short wave #1 oscillator trimmer screw (C5) for maximum signal. Next set the generator at 23 MC. and tune in this signal on receiver. Adjust short wave #1 R.F. trimmer screw (C2) for maximum signal. The low frequency end of the dial is automatically adjusted by a fixed padder condenser. Next turn band switch to short wave #2 position. Rotate drive shaft until variable condenser of the receiver is open all the way. Adjust generator to 8 MC. Adjust the short wave #2 oscillator trimmer screw (C4) until maximum signal is secured. Next set generator at 7 MC. Tune in this signal on receiver, and adjust short wave #2 R.F. trimmer screw (C1) for maximum signal strength. The low frequency end of the dial is automatically adjusted by a fixed padder condenser. Next turn band switch to broadcast position. Adjust generator to produce 1500 KC. and tune in this signal on receiver. Adjust the broadcast oscillator trimmer screw (C3) for maximum signal. To adjust the low end of the dial, set the generator and receiver at 600 KC. Peak the broadcast padder (C7) for maximum output. The variable condenser should be rocked slightly during this operation. Keep the signal generator output as low as possible when making all these adjustments.

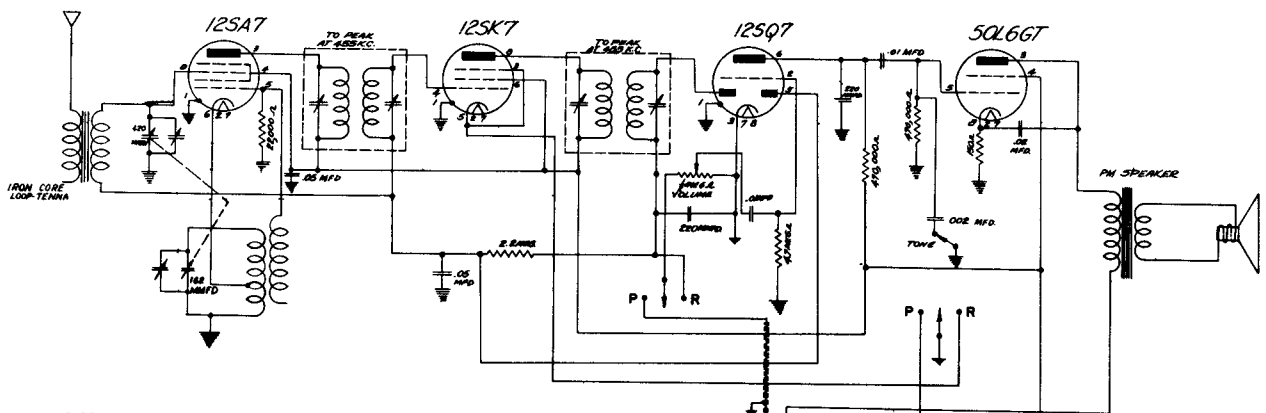

DeWALD Radio Model E-522

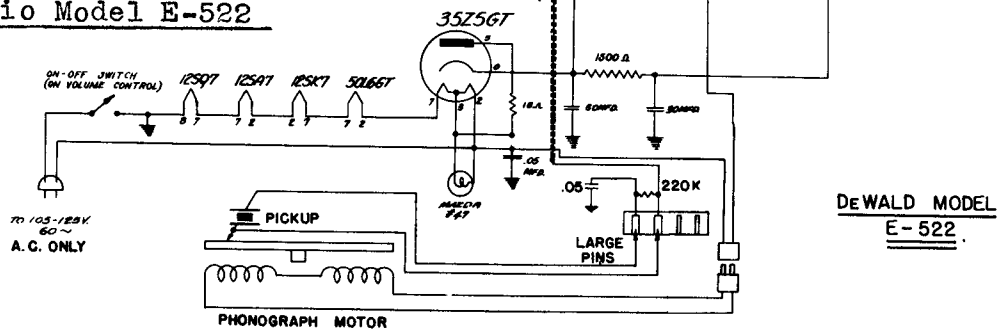

DeWALD MODEL
E-522

Emerson Radio

MODEL 634B

MODEL 672B

CHASSIS MODEL 120097-B

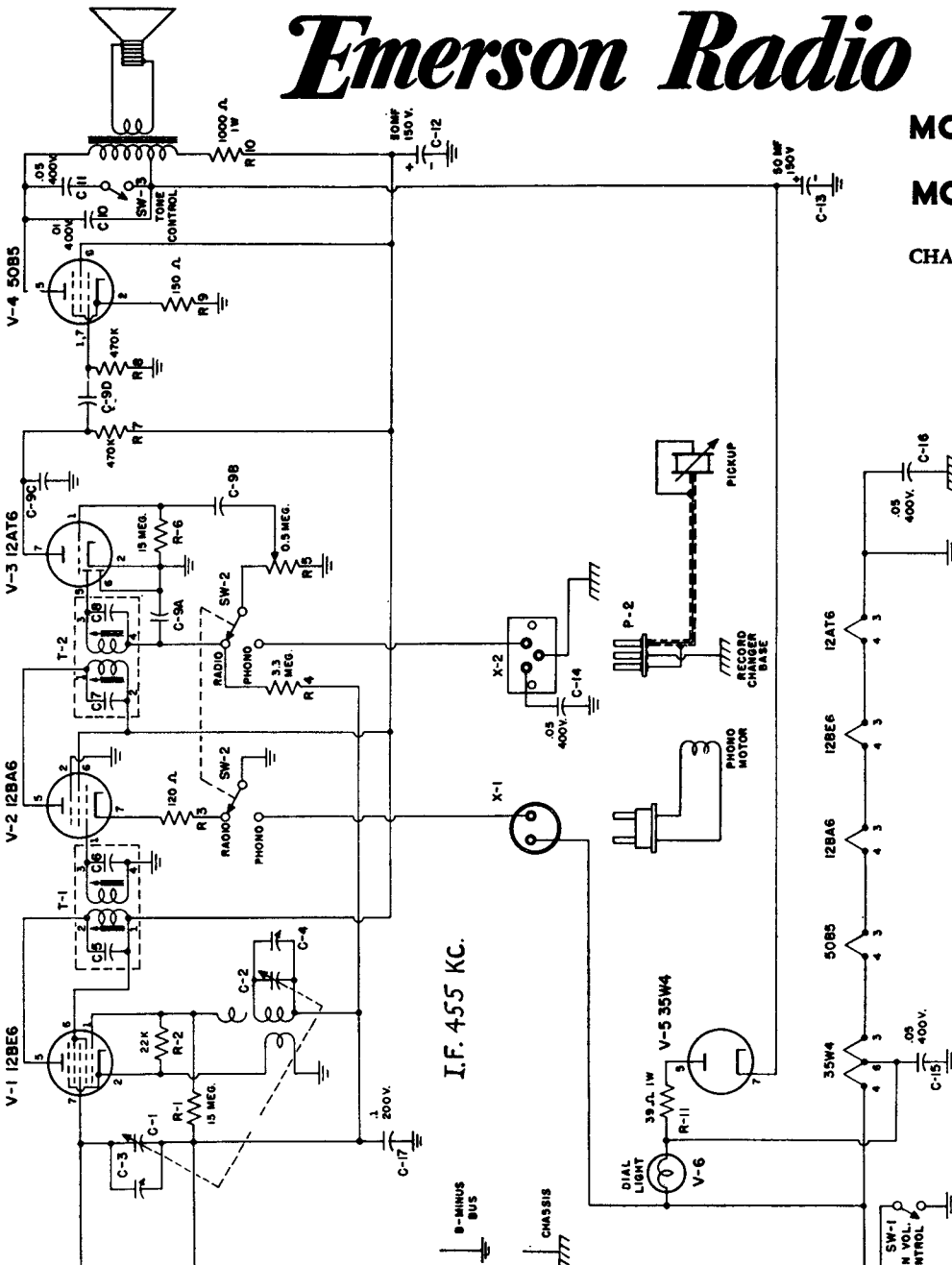

CONDITIONS FOR VOLTAGE AND RESISTANCE READINGS

Voltages indicated are positive d.c., resistances are in ohms, unless otherwise indicated. Measurements made with voltohmmyst or equivalent. Line voltage maintained at 120 volts a.c. for voltage measurements. Socket connections are shown as bottom views, with measurements from pin to common negative. Volume control at maximum; radio-phonograph switch in radio position; no signal applied for Model 634B measurements. Nominal tolerance on component values makes possible a variation of $\pm 15\%$ in voltage and resistance readings. On the diagrams, upper values are voltage; lower values are resistance. NC denotes no connection, K is kilohms, MEG megohms, INF. is infinity. Resistances marked * are measured to pin 7 of rectifier (B+).

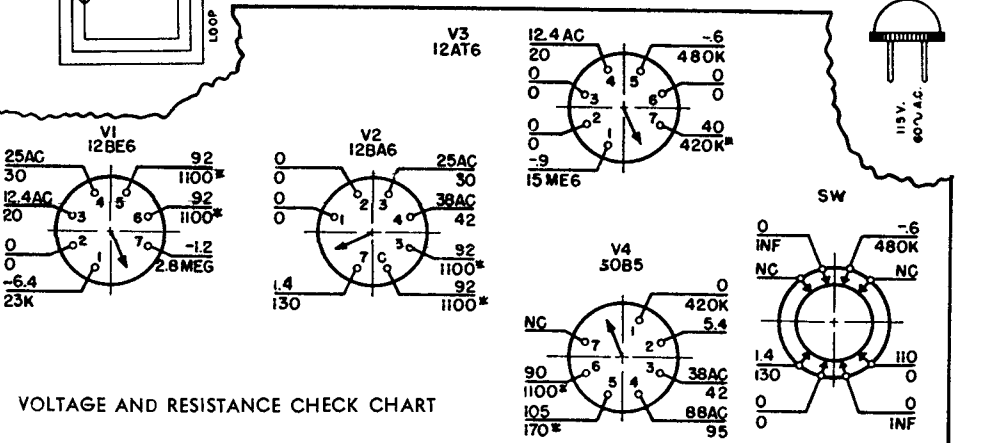

VOLTAGE AND RESISTANCE CHECK CHART

MANUAL OF 1951 MOST-OFTEN-NEEDED RADIO DIAGRAMS

EMERSON RADIO & PHONOGRAPH CORPORATION

MODEL: 625

CHASSIS MODEL: 120105B

TYPE: Automatic record-changer phonograph

TYPE OF TUBES:

1—12SQ7 audio amplifier

1—50L6GT power output

1—35Z5GT rectifier

POWER SUPPLY: 60 cycle a.c. only

VOLTAGE RATING: 105-125 volts

POWER CONSUMPTION: 30 watts

CURRENT DRAIN: 0.25 amp. at 117 volts a.c.

DISASSEMBLY INSTRUCTIONS

1. Remove two push-on knobs at front of cabinet.
2. Disconnect phono-motor leads by unscrewing wirenuts.
3. Remove phono pickup plug.
4. Unscrew two front cabinet feet and two chassis bolts at sides of cabinet. Lift out chassis.
5. Remove two base plate screws at center of chassis.

CONDITIONS FOR VOLTAGE AND RESISTANCE READINGS

1. Voltages indicated are positive d.c., resistances are in ohms, unless otherwise indicated.
2. Measurements made with voltohmmyst or equivalent.
3. Line voltage maintained at 117 volts a.c. for voltage measurements.
4. Socket connections are shown as bottom views, with measurements from pin to common negative.
5. Volume control at maximum, for voltage measurements.
6. Nominal tolerance on component values makes possible a variation of $\pm 15\%$ in voltage and resistance readings.
7. On the diagram, upper values are voltage and lower values are resistance. NC denotes no connection, K is kilohms, MEG is megohms, INF is infinity. Resistances marked * are measured to pin 8 of rectifier (B+).

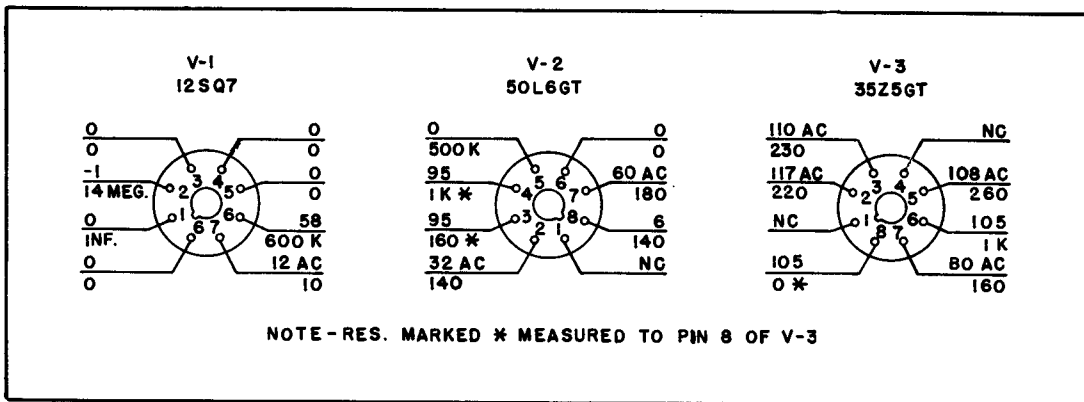

BOTTOM VIEW - CHASSIS 120105B

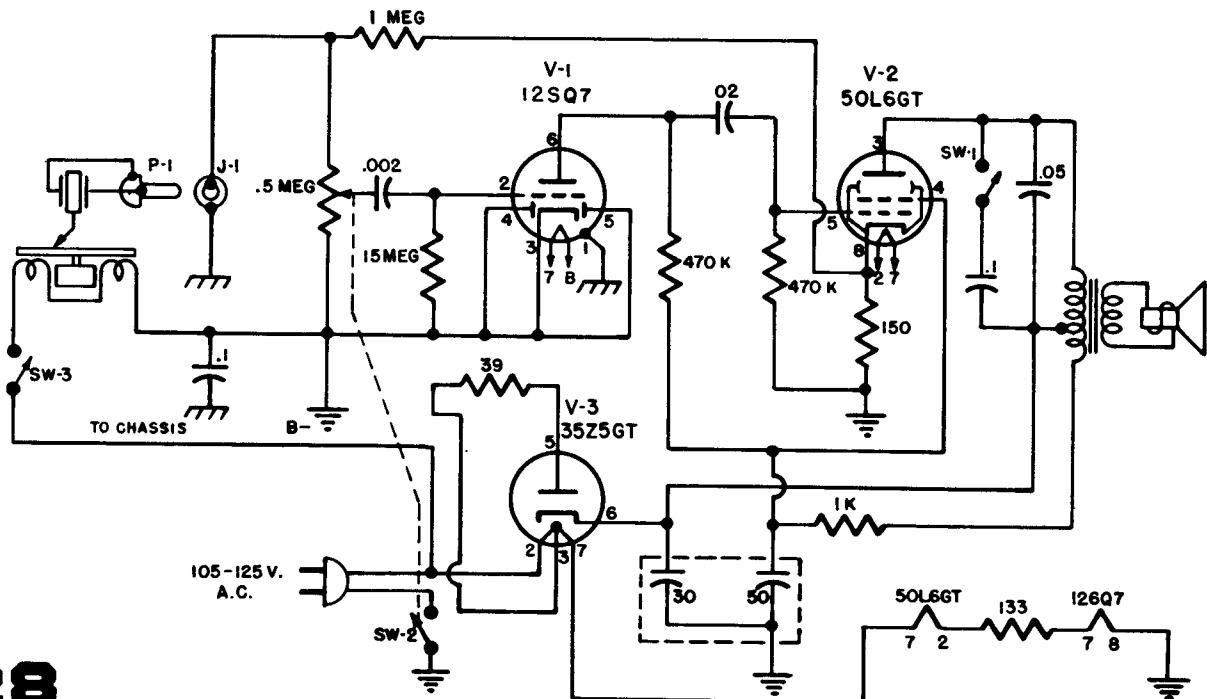

MANUAL OF 1951 MOST-OFTEN-NEEDED RADIO DIAGRAMS

Emerson Radio

MODEL: 641B

CHASSIS MODEL: 120125B

VOLTAGE READINGS FOR CHASSIS 120125-B

SYMBOL	TUBE	PIN 1	PIN 2	PIN 3	PIN 4	PIN 5	PIN 6	PIN 7
V-1	6BJ6	-1.2 DC	1 DC	18 AC	12 AC	85 DC	35 DC	0
V-2	6BJ6	-9.2 DC	0	24 AC	18 AC	85 DC	85 DC	0
V-3	6BJ6	0	1.4 DC	30 AC	36 AC	68 DC	85 DC	0
V-4	6BJ6	-1.3 DC	.65 DC	30 AC	24 AC	85 DC	85 DC	0
V-5	12AT6	-8 DC	0	36 AC	12 AC	0	-.65 DC	42 DC
V-6	50C5	5.4 DC	0	80 AC	80 AC	0	85 DC	100 DC
V-7	35W4	85 DC	NC	80 AC	115 AC	110 AC	110 AC	110 DC

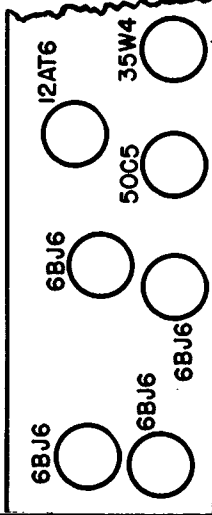

A.C. and D.C. measurements are taken with a V.T.V.M.
 Measured values are from socket pin to common negative (B-).
 Line voltage maintained at 115V A.C. for voltage readings.
 Nominal tolerance on component values makes possible a variation of ± 15%
 Volume control at maximum with no signal applied, for voltage measurement.

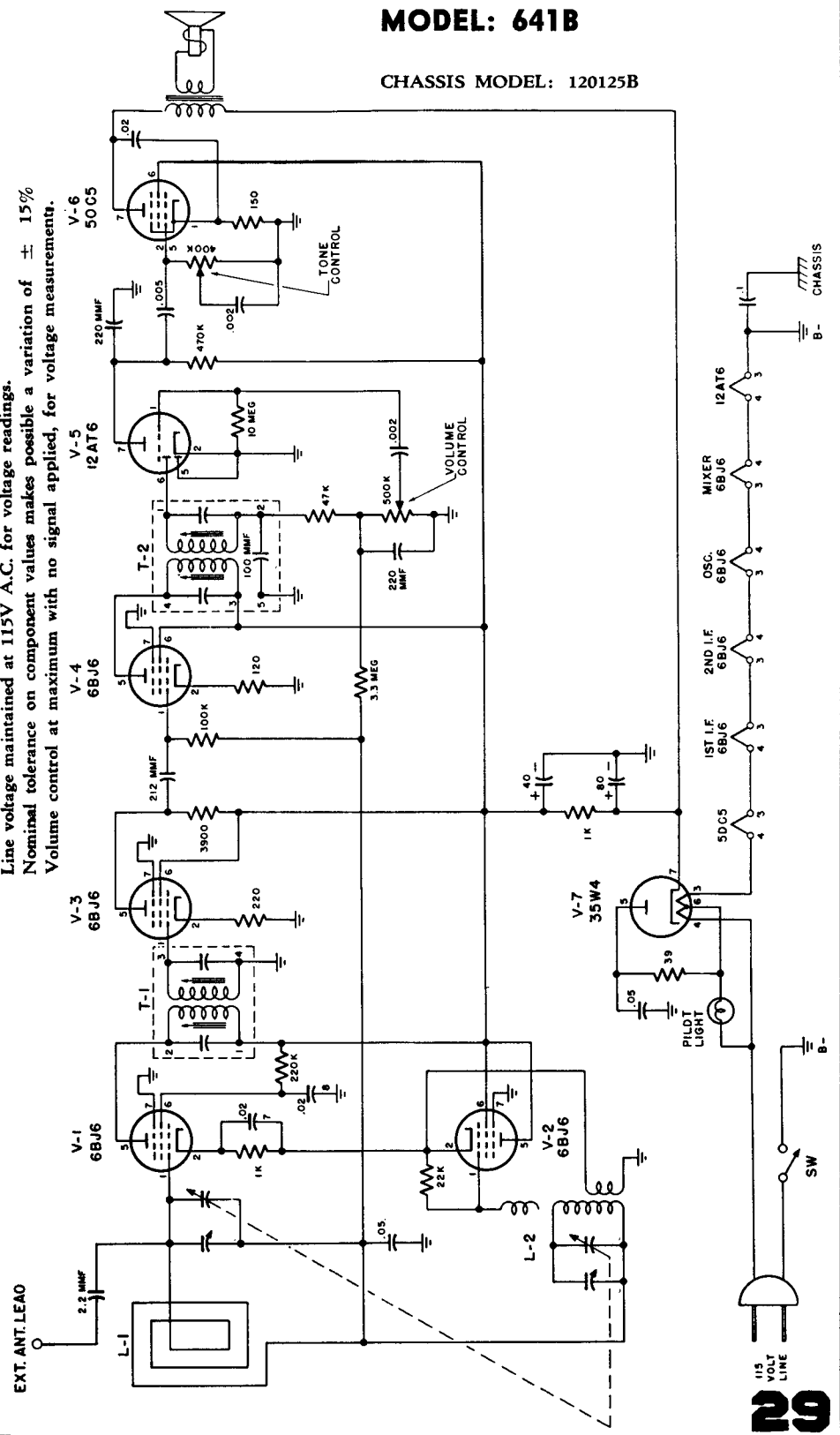

CHASSIS	SYMBOL	TUBE TYPE	PIN 1	PIN 2	PIN 3	PIN 4	PIN 5	PIN 6	PIN 7
120121A 120121B	V1	1R5	0	95	60	-6.2	0	0	1.3
	V2	1U4	2.8	95	95	0	2.8	.05	4.0
	V3	1U5	1.3	16	15	.05	.01	.01	2.5
	V4	3V4	4	95	95	0	5.2	0	6.5
	V5	117Z3	N.C.	115	115 AC	0	115 AC	116	115

RESISTANCE READINGS

CHASSIS	SYMBOL	TUBE TYPE	PIN 1	PIN 2	PIN 3	PIN 4	PIN 5	PIN 6	PIN 7
120121A 120121B	V1	1R5	0	3800	20K	100K	0	3 Meg.	17
	V2	1U4	30	3800	3800	Inf.	34	3.3 Meg.	38
	V3	1U5	17	1 Meg.	3 Meg.	1 Meg.	3 Meg.	10 Meg.	30
	V4	3V4	38	4000	3800	330	42	3.3 Meg.	54
	V5	117Z3	N.C.	2000	480	0	480	2000	2000

NC=no connection;

Inf.=infinity;

K=kilohms;

Meg.=megohms

ALIGNMENT PROCEDURE

1. Use battery power when available. When a.c. power is used, connect the line cord through an isolation transformer if available. Otherwise connect a 0.1 mfd. condenser in series with the low side of the signal generator and B—.
2. Set the volume control at maximum. The output of the signal generator should be no higher than that necessary to obtain an output reading. Attenuate the signal input as alignment proceeds. Use an insulated alignment tool.
3. Maintain the loop in the same position relative to the chassis as when the receiver is in the cabinet.

	DUMMY ANTENNA	SIGNAL GENERATOR COUPLING	SIGNAL GENERATOR FREQUENCY	RADIO DIAL SETTING	OUTPUT METER	ADJUST*	REMARKS
1	0.1 mfd.	High side to pin 6 (grid) of V1 (1R5). Low side to chassis	455 kc	Variable condenser fully open.	Across voice coil.	A1, (2nd i-f trans), A2, A3 (1st i-f trans.)	Adjust for maximum output. If a.c. is used without an isolation transformer, reduce dummy antenna to 200 mmf. to reduce hum modulation.
2	200 mmf.	High side to external ant. lead. Low side to chassis	1620 kc	Variable condenser fully open.	Across voice coil.	A4 (trimmer cond. C4.)	Adjust for maximum output.
3	200 mmf.	"	1400 kc	Tune for maximum output.	Across voice coil.	A5 (trimmer cond. C2.)	Adjust for maximum output.

30

MANUAL OF 1951 MOST-OFTEN-NEEDED RADIO DIAGRAMS

EMERSON RADIO

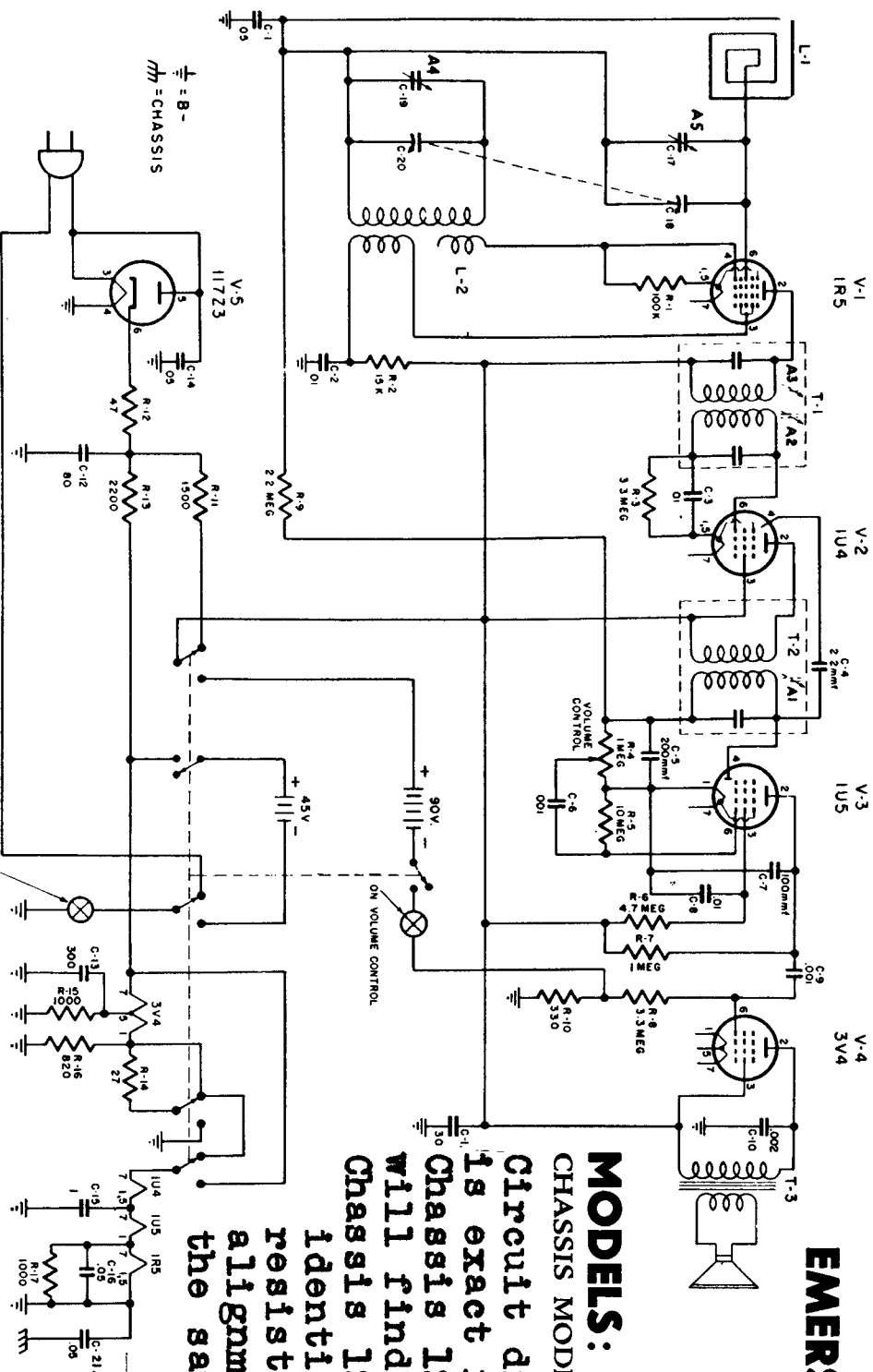

MODELS: 646A, 646B
 CHASSIS MODELS: 120121A, 120121B

Circuit diagram shown is exact for Model 646B Chassis 120121B. You will find Model 646A, Chassis 120121A almost identical. Voltage, resistance, and alignment data is the same for both.

Voltage and resistance measurements taken from socket pin to chassis. VTVM used. V.C. at maximum, no signal. Line voltage: 117 volts A.C.

VOLTAGE READINGS

N.C. Denotes "No Connection."
 *Denotes Bandswitch in FM Position Only.

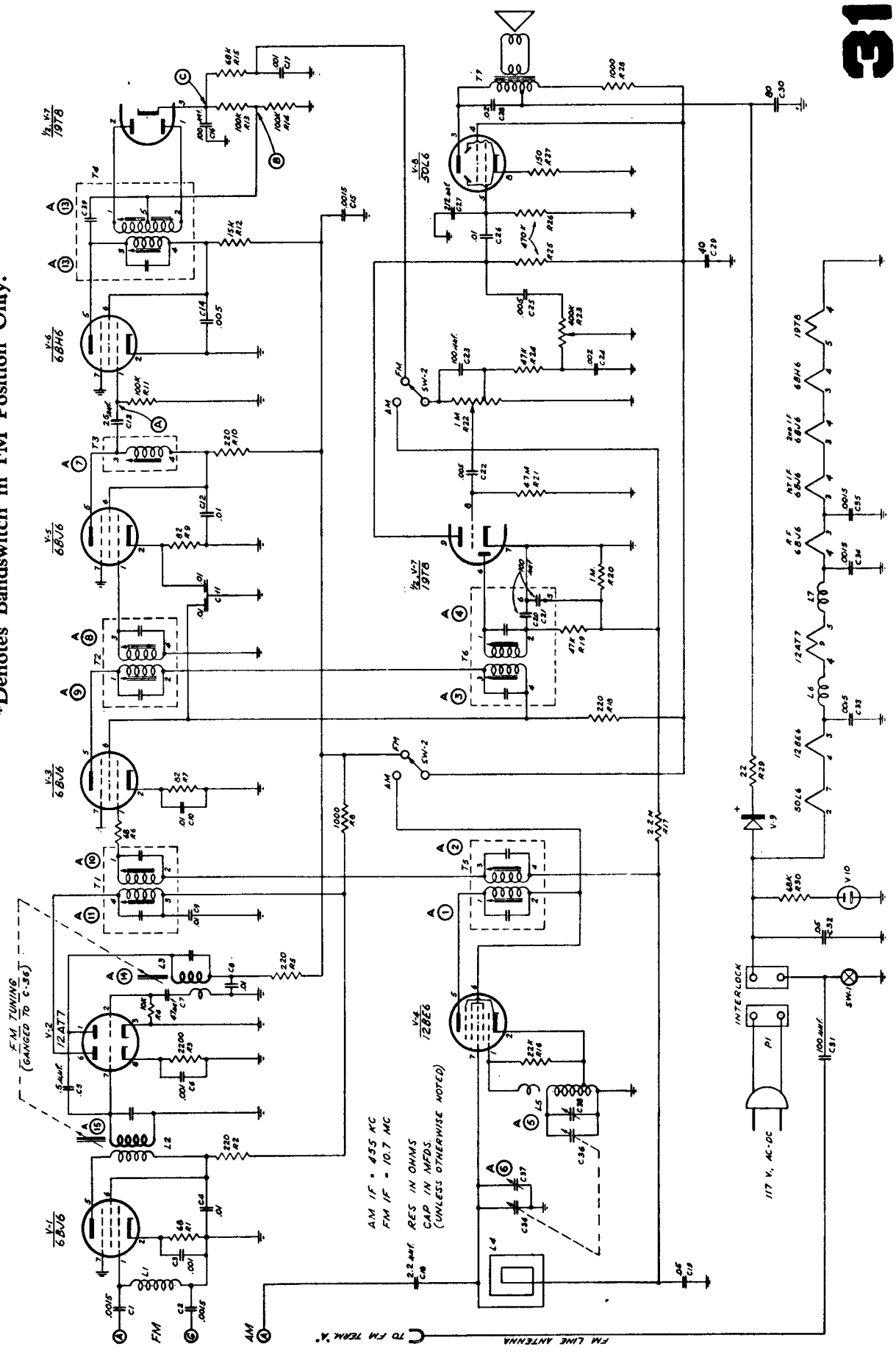

MANUAL OF 1951 MOST-OFTEN-NEEDED RADIO DIAGRAMS

Emerson Radio

MODEL: 659B

CHASSIS MODEL: 120126-B

INSTRUCTIONS FOR VOLTAGE AND RESISTANCE READINGS

1. Voltages readings are in d.c. volts and resistance reading in ohms, unless otherwise specified.
2. D.c. voltage measurements are made at 20,000 ohms-per-volt and a.c. voltages are measured at 1000 ohms-per-volt.
3. Socket connections are shown as bottom views. Values are measured from socket pin to common negative.
4. Line voltage maintained at 115 volts a.c. for voltage readings.
5. Nominal tolerance on component values makes possible a variation of $\pm 15\%$ in readings.
6. Volume control at maximum, with no signal applied and bandswitch in broadcast position (unless otherwise noted), for voltage measurements.

VOLTAGE READINGS (CHASSIS 120126-B)

SYMBOL	TUBE	PIN 1	PIN 2	PIN 3	PIN 4	PIN 5	PIN 6	PIN 7	PIN 8	PIN 9
V-1	6BJ6	0	.6*	35 AC	41 AC	78*	78*	0	—	—
V-2	12AT7	86*	-2.8*	0	53 AC	41 AC	80*	0	1.7*	NC
V-3	6BJ6	-.4	.8	35 AC	30 AC	100	100	0	—	—
V-4	12BE6	-7.6	0	53 AC	.64 AC	100	100	-.4	—	—
V-5	6BJ6	0	.7*	30 AC	24 AC	86*	86*	0	—	—
V-6	6BH6	-.3	0	24 AC	18 AC	50*	50*	0	—	—
V-7	19T8	-.5*	-.6*	-.1*	0	18 AC	-.5	0	-.5	40
V-8	50L6	NC	115 AC	110	105	0	NC	64 AC	7.2	—

RESISTANCE READINGS (CHASSIS 120126-B)

SYMBOL	TUBE	PIN 1	PIN 2	PIN 3	PIN 4	PIN 5	PIN 6	PIN 7	PIN 8	PIN 9
V-1	6BJ6	0	68	42	50	200K*	200K*	0	—	—
V-2	12AT7	200K*	10K	0	62	50	200K*	0	2200	NC
V-3	6BJ6	3.2 meg.	82	42	35	200K*	200K*	0	—	—
V-4	12BE6	22K	.5	62	75	200K	200K	2.7 meg.	—	—
V-5	6BJ6	.6	82	35	28	200K*	200K*	0	—	—
V-6	6BH6	100K	0	28	20	200K*	200K*	0	—	—
V-7	19T8	100K	100K	175K*	0	20	500K	0	4.7 meg.	500K
V-8	50L6	NC	130	200K	200K	470K	NC	75	150	—

Emerson Radio

MODEL: 671D

CHASSIS: 120137-D

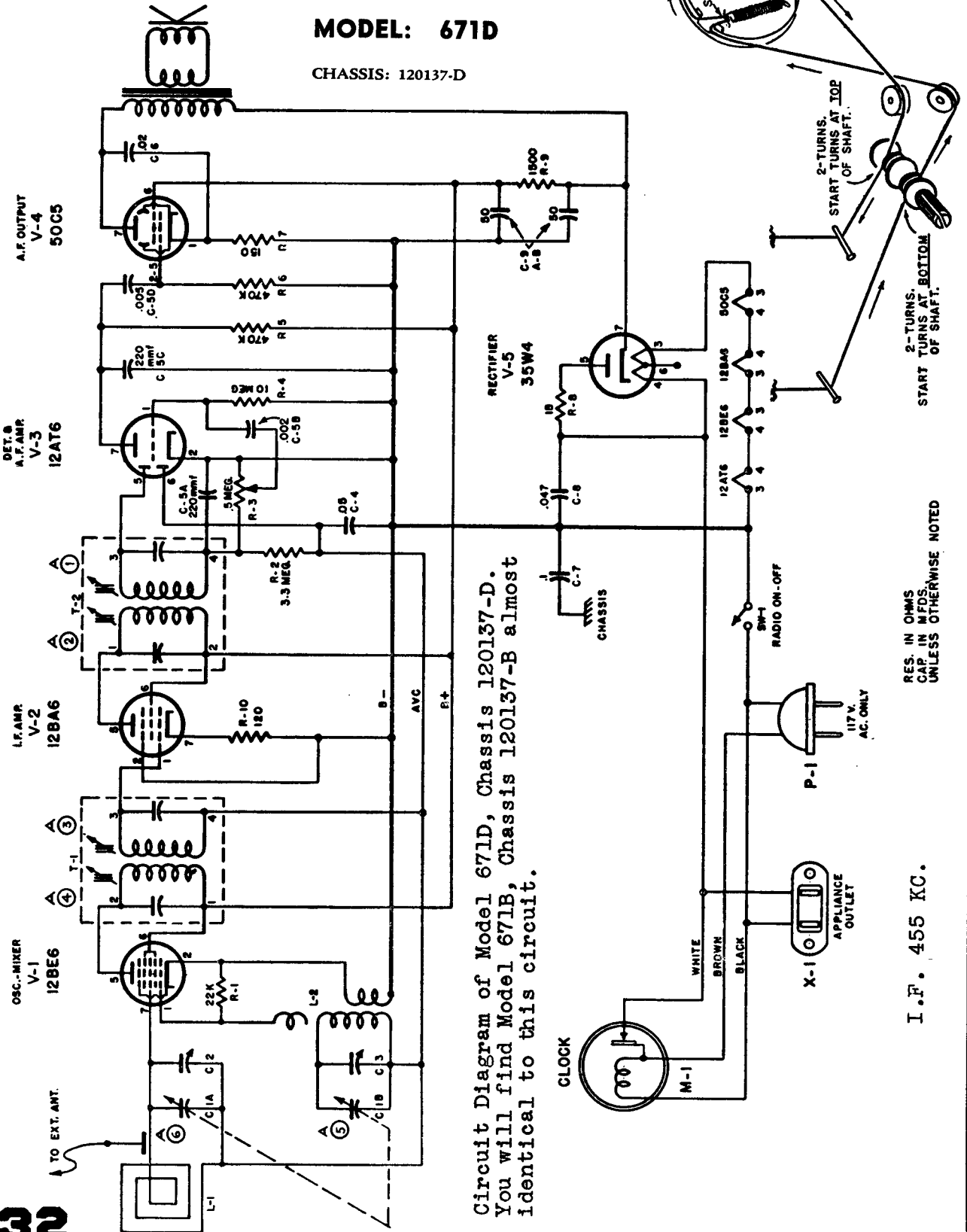

Circuit Diagram of Model 671D, Chassis 120137-D. You will find Model 671B, Chassis 120137-B almost identical to this circuit.

RES. IN OHMS
CAP. IN MFD.
UNLESS OTHERWISE NOTED

I.F. 455 KC.



MANUAL OF 1951 MOST-OFTEN-NEEDED RADIO DIAGRAMS

Emerson Radio

MODEL: 679B

CHASSIS MODEL: 120116-B

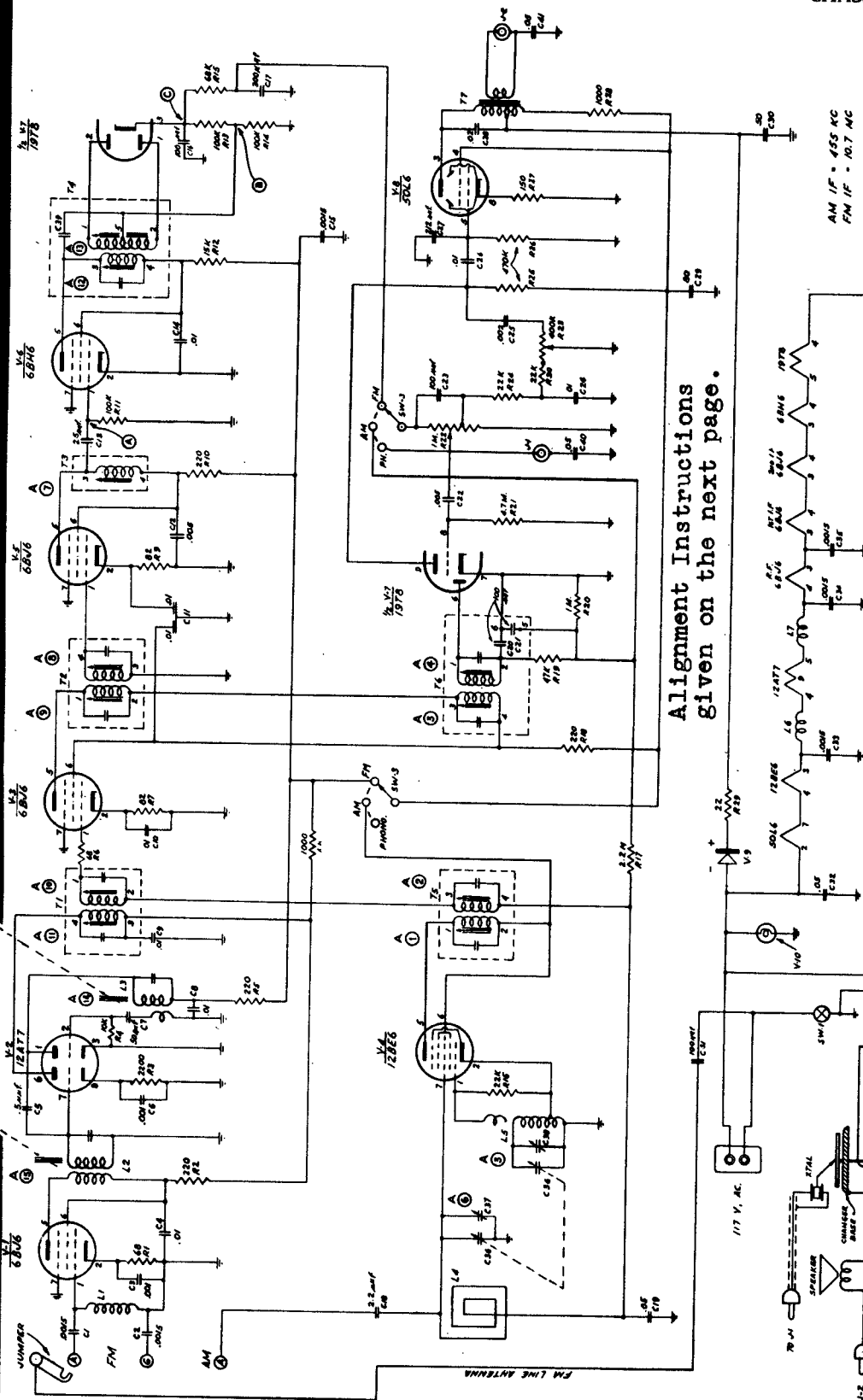

Alignment Instructions given on the next page.

AM IF = 455 KC
FM IF = 10.7 MC
RES. IN OHMS
CAP. IN MFD.
(UNLESS OTHERWISE NOTED)

VOLTAGE READINGS (CHASSIS 120116-B)

SYMBOL	TUBE	PIN 1	PIN 2	PIN 3	PIN 4	PIN 5	PIN 6	PIN 7	PIN 8	PIN 9
V-1	6BJ6	0	.6 V.*	35 V.AC	41 V.AC	78 V.*	78 V.*	0	1.7 V.*	N.C.
V-2	12AT7	86 V.*	-2.8 V.*	0	53 V.AC	41 V.AC	80 V.*	0	0	0
V-3	6BJ6	-4 V	.8 V.	35 V.AC	30 V.AC	100 V.	100 V.	0	0	0
V-4	12BE6	-7.6 V	0	53 V.AC	64 V.AC	100 V.	100 V.	-4 V	0	0
V-5	6BJ6	0	.7 V.*	30 V.AC	24 V.AC	86 V.*	86 V.*	0	0	0
V-6	6BH6	-3 V.	0	24 V.AC	18 V.AC	50 V.*	50 V.*	0	0	0
V-7	19T8	-5 V.*	-6 V.*	-1 V.*	0	18 V.AC	-5 V.	0	-5 V.	40 V.
V-8	50L6	N.C.	115V.AC	110 V.	105 V.	0	N.C.	64 V.AC	7.2 V.	0

N.C. Denotes "No Connection."

*Bandswitch in F.M. Position Only.



MANUAL OF 1951 MOST-OFTEN-NEEDED RADIO DIAGRAMS

EMERSON RADIO

ALIGNMENT INSTRUCTIONS, MODEL 679B, continued.

To position pointer, turn variable condenser fully closed and set pointer to reference mark on dial backplate at the low frequency end of the dial. Volume control should be set at maximum position. The output of the signal generator should be no higher than necessary to obtain an output reading. Attenuate the signal input as alignment proceeds. Use an insulated alignment tool for all adjustments. Use isolation transformer if available; otherwise connect a .1 mfd. condenser in series with low side of signal generator to chassis.

AM ALIGNMENT

	DUMMY ANTENNA	SIGNAL GENERATOR COUPLING	SIGNAL GENERATOR FREQUENCY	BAND SWITCH POSITION	RADIO DIAL SETTING	OUTPUT METER	ADJUST	REMARKS
1	.1 mfd.	High side to Pin 7 (grid) of 12BE6. Low side to chassis.	455 KC.	Broadcast	Tuning condenser fully open.	Across voice coil.	A1, A2, (Trans. T4). A3, A4, (Trans. T2).	Adjust for maximum output. Reduce dummy antenna to .001 mfd. if isolation trans. is not used.
2		Loop	1620 KC.	Broadcast	Tuning condenser fully open.	Across voice coil.	A5, (Trimmer cond. C6).	Form loop of several turns of wire. Radiate signal into receiver loop. Adjust for maximum output.
3		Loop	1400 KC.	Broadcast	Tune for max. outpt.	Across voice coil.	A6, (Trimmer cond. C5).	Adjust for maximum output.

FM I-F and Disc. Alignment Using AM Signal Generator and VTVM

	DUMMY ANTENNA	SIGNAL GENERATOR COUPLING	SIGNAL GENERATOR FREQUENCY	BAND SWITCH POSITION	RADIO DIAL SETTING	CONNECT VTVM	ADJUST	REMARKS
1	.01 mfd.	High side to Pin 1 (grid) of 6BJ6 2nd i-f (V5). Low side to chassis.	10.7 mc. (Unmodulated)	Frequency modulation	Tuning condenser fully open.	Connect d.c. probe to point "A". Common to chassis.	A7, (Trans. T5).	Adjust for maximum output.
2	.01 mfd.	High side to Pin 1 (grid) of 6BJ6 1st i-f (V3). Low side to chassis.	10.7 mc. (Unmodulated)	Frequency modulation	Tuning condenser fully open.	Connect d.c. probe to point "A". Common to chassis.	A8, A9, (Trans. T3).	Adjust for maximum output.
3	.01 mfd.	High side to Pin 7 of 12AT7 conv. (V2). Low side to chassis.	10.7 mc. (Unmodulated)	Frequency modulation	Tuning condenser fully open.	Connect d.c. probe to point "A". Common to chassis.	A10, A11, (Trans. T1).	Adjust for maximum output.
4	.01 mfd.	High side to Pin 1 (grid) of 6BJ6 2nd i-f (V5). Low side to chassis.	10.7 mc. (Unmodulated)	Frequency modulation	Tuning condenser fully open.	Connect d.c. probe to point "B". Common to chassis.	A12, (Trans. T6).	Adjust for maximum output.
5	.01 mfd.	"	10.7 mc. (Unmodulated)	Frequency modulation	Tuning condenser fully open.	Connect d.c. probe to point "C". Common to chassis.	A13, (Trans. T6).	Adjust for zero output, Continue with FM r-f alignment.

FM I-F AND DISC. ALIGNMENT USING SWEEP SIGNAL GENERATOR AND OSCILLOSCOPE. Use frequency modulated signal, with 60 cycle modulation and 450 Hz sweep. Use 120 cycle sawtooth sweep voltage in oscilloscope for horizontal deflection.

	DUMMY ANTENNA	SIGNAL GENERATOR COUPLING	SIGNAL GENERATOR FREQUENCY	BAND SWITCH POSITION	RADIO DIAL SETTING	CONNECT OSCILLOSCOPE	ADJUST	REMARKS
1	.01 mfd.	High side to Pin 1 (grid) of 6BJ6 1st i-f (V3). Low side of chassis.	10.7 mc. (Unmodulated).	Frequency modulation	Tuning condenser fully open.	Vertical input to Point "A". Ground to chassis.	A7, A8, A9, (Trans. T5 and T3).	Adjust for maximum output (height) and symmetry as per i-f alignment curve shown.
2	.01 mfd.	High side to Pin 7 of 12AT7 of conv. (V2). Low side to chassis.	10.7 mc. (Unmodulated).	Frequency modulation	Tuning condenser fully open.	Vertical input to Point "A". Ground to chassis.	A10, A11, (Trans. T1)	Adjust for maximum output (height) and symmetry as per i-f alignment curve shown.
3	.01 mfd.	High side to Pin 1 (grid) of 6BJ6 2nd i-f (V5). Low side to chassis.	10.7 mc. (Unmodulated).	Frequency modulation	Tuning condenser fully open.	Vertical input to Point "C". Ground to chassis.	A12, A13, (Trans. T6).	Alternately adjust A12 for maximum amplitude and A13 for maximum straightness of cross-over lines, with cross-over occurring at center of pattern as per discriminator alignment curve. Continue with FM r-f alignment.

FM R-F ALIGNMENT

	DUMMY ANTENNA	SIGNAL GENERATOR COUPLING	SIGNAL GENERATOR FREQUENCY	BAND SWITCH POSITION	RADIO DIAL SETTING	CONNECT VTVM	ADJUST	REMARKS
1	300 ohm resistor in series with gen. lead.	High side to FM ant. term. Low side to chassis.	109.0 mc. (Unmodulated).	Frequency modulation	Tuning condenser fully open	Connect d.c. probe to point "A". Common to chassis	A14 (Iron Core)	Adjust for maximum output.
2	"	"	106.0 mc.	Frequency modulation	Tune for maximum output.	"	A15 (Iron Core)	Adjust for maximum output.

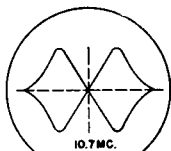
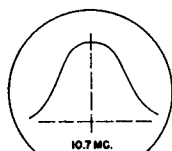

ALIGNMENT CURVES (FM)

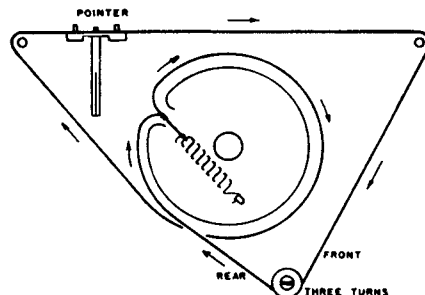

MANUAL OF 1951 MOST-OFTEN-NEEDED RADIO DIAGRAMS

FADA RADIO & ELECTRIC CO., Inc.

Model P111

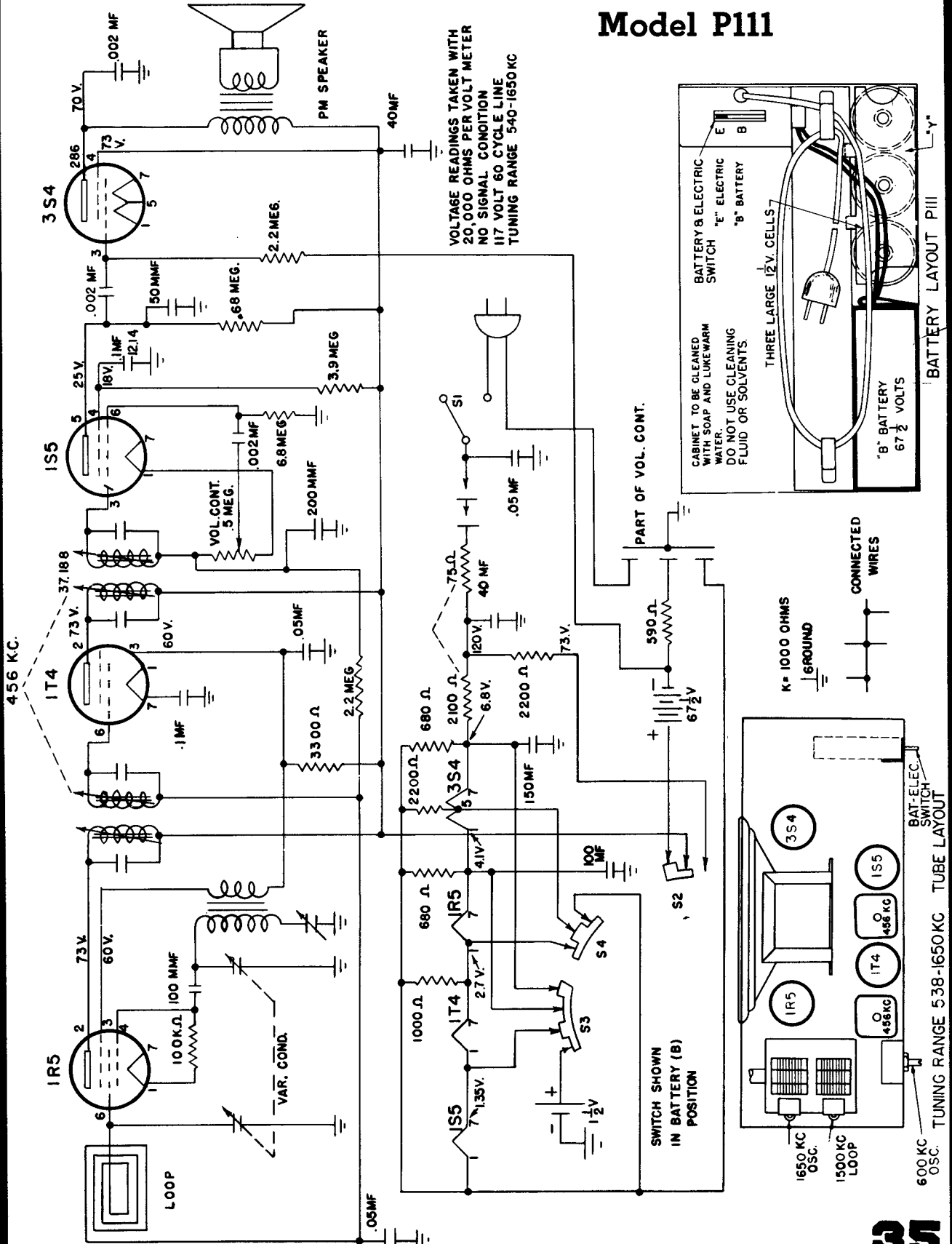

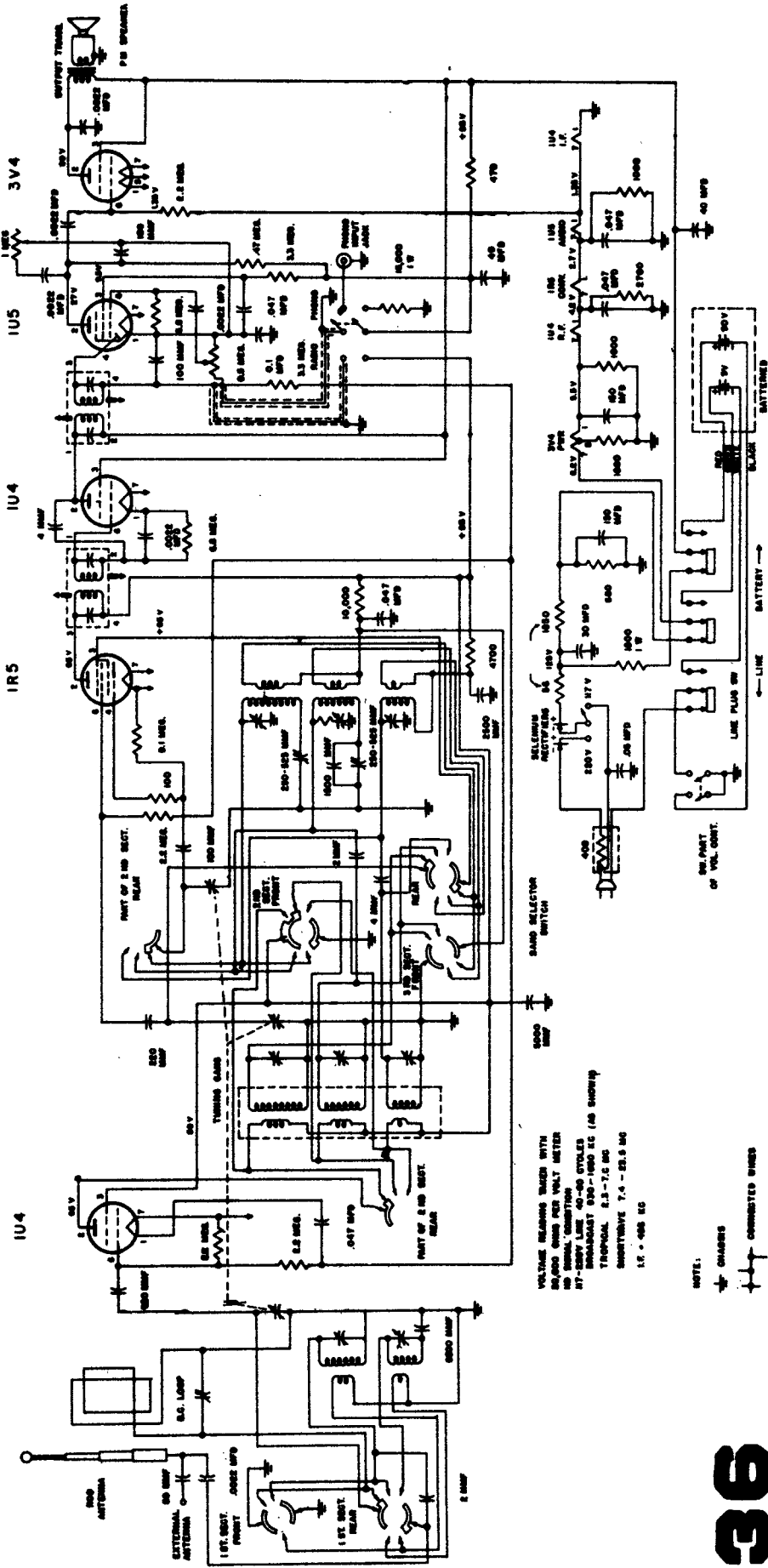

NOTE: VOLTAJE RELAYAS BAKEN WITH
 250V CHAS PER WALT METER
 IN SERIAL POSITION
 17-250V LINE 40-60 CYCLES
 WIRING DIAGRAM 320-1800 EC (40 SHORTH)
 TYPICAL 2.2-7.0 MC
 SUBSTITUTIVE 7.4 - 22.5 MC
 I.C. - 408 EC

NOTE:
 CHASSIS
 CONNECTED WIRING

36

MANUAL OF 1951 MOST-OFTEN-NEEDED RADIO DIAGRAMS

FADA RADIO & ELECTRIC CO., Inc.

Model P-130

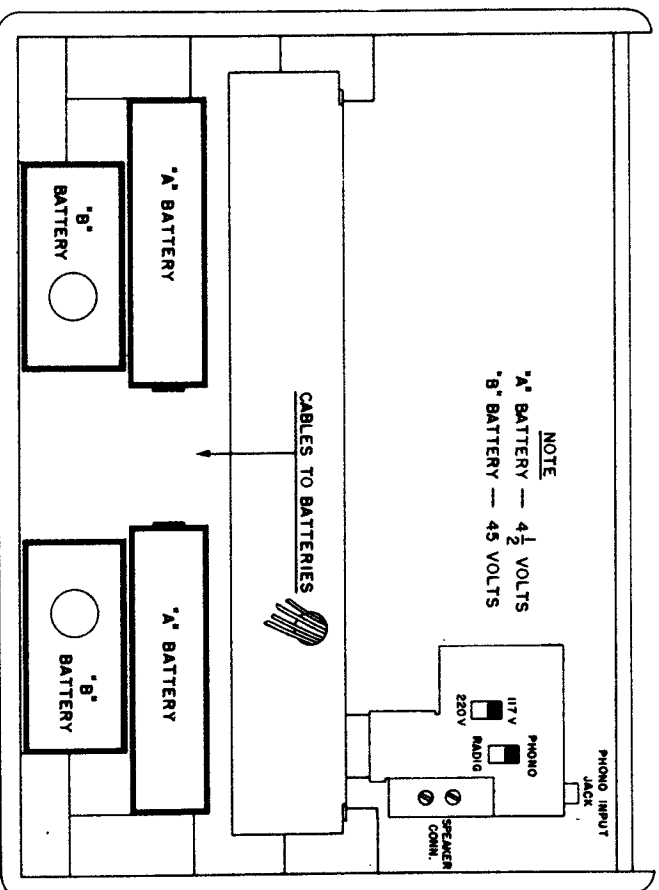

BATTERY LAYOUT P130

Portable Receiver designed for operation from 105-125 volts, 40-60 cycles A.C. or the same voltage D.C., or 180-220 volts, 40-60 cycles A.C., or from batteries.

Frequency ranges are:

530 KC to 1650 KC,

2.3 MC to 7.6 MC, and

7.4 MC to 23.5 MC.

I.F. 456 KC.

Speaker: 5" P.M., 1.47 oz.

Alnico V Magnet.

Voice coil: 3.2 ohms.

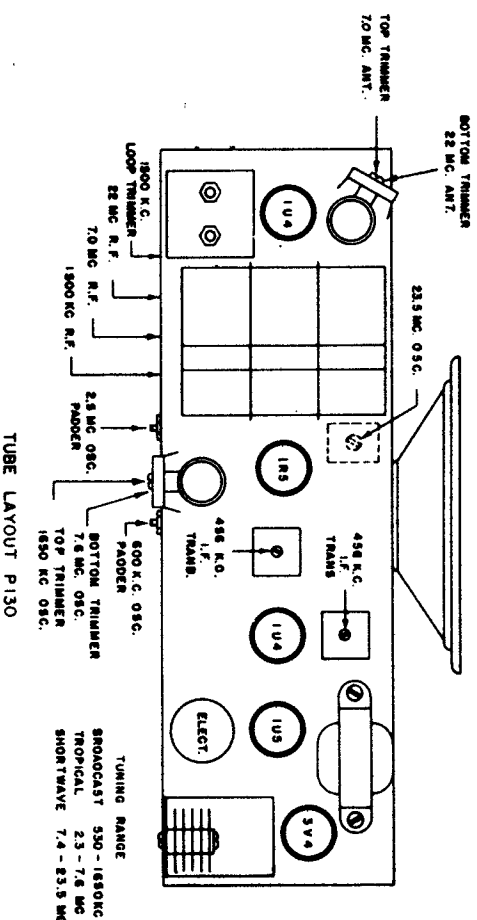

TUBE LAYOUT P130

TO SIG. GEN.

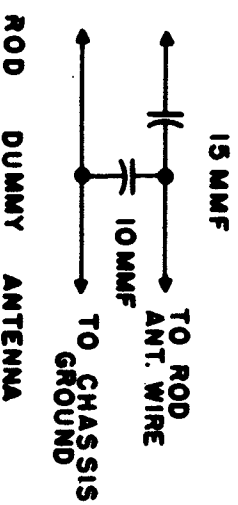

MANUAL OF 1951 MOST-OFTEN-NEEDED RADIO DIAGRAMS

THE FIRESTONE TIRE & RUBBER CO.

4-B-58 and 4-B-61

Firestone Auto Radio 4-B-61 (Code 120-1-C351) is for 1951 Chevrolet; and 4-B-58 (Code 120-0-D200) is for 1949 & 1950 Dodge and Plymouth. Both sets use identical circuit.

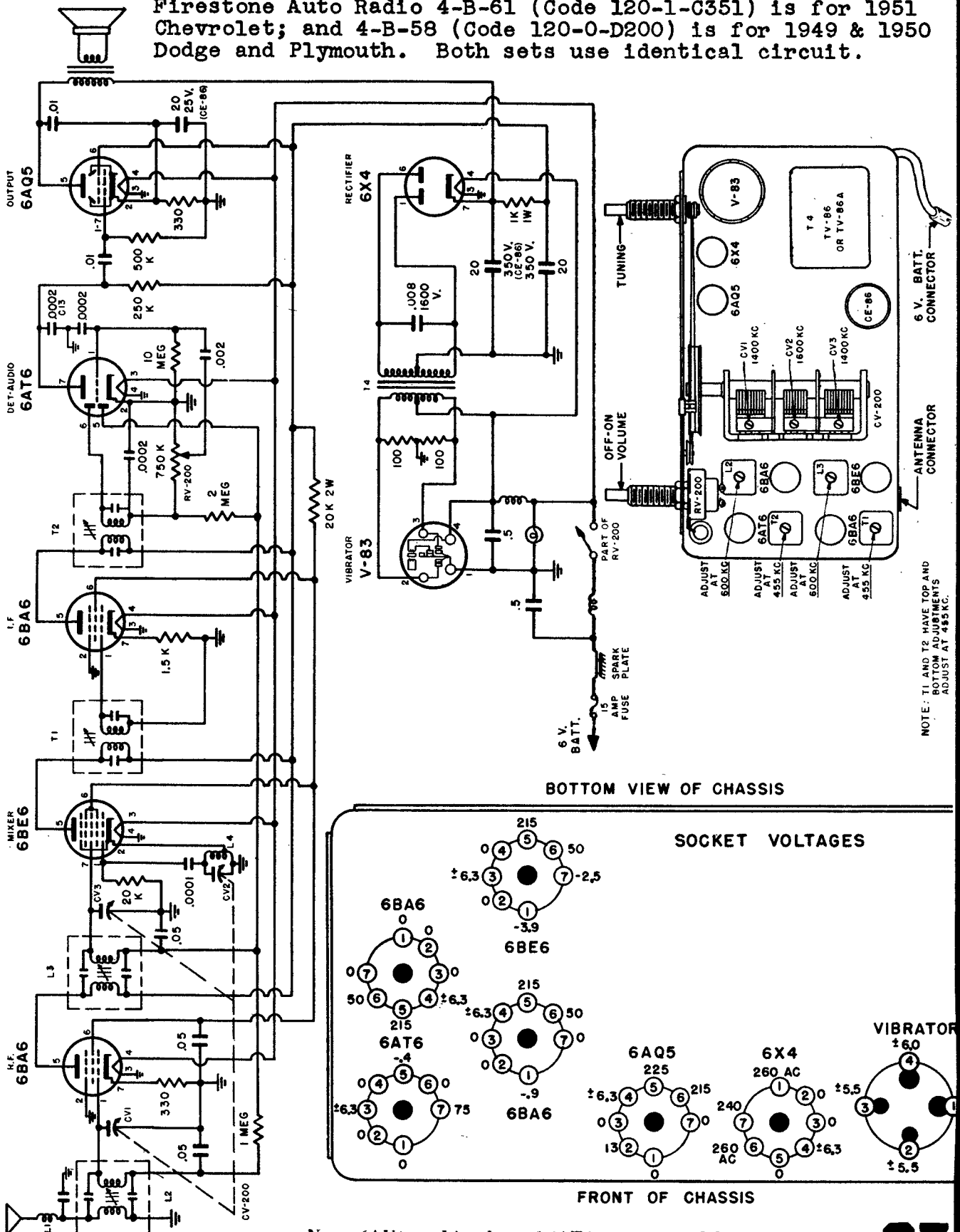

Note: 6AV6 used in place of 6AT6 on some models.

MANUAL OF 1951 MOST-OFTEN-NEEDED RADIO DIAGRAMS

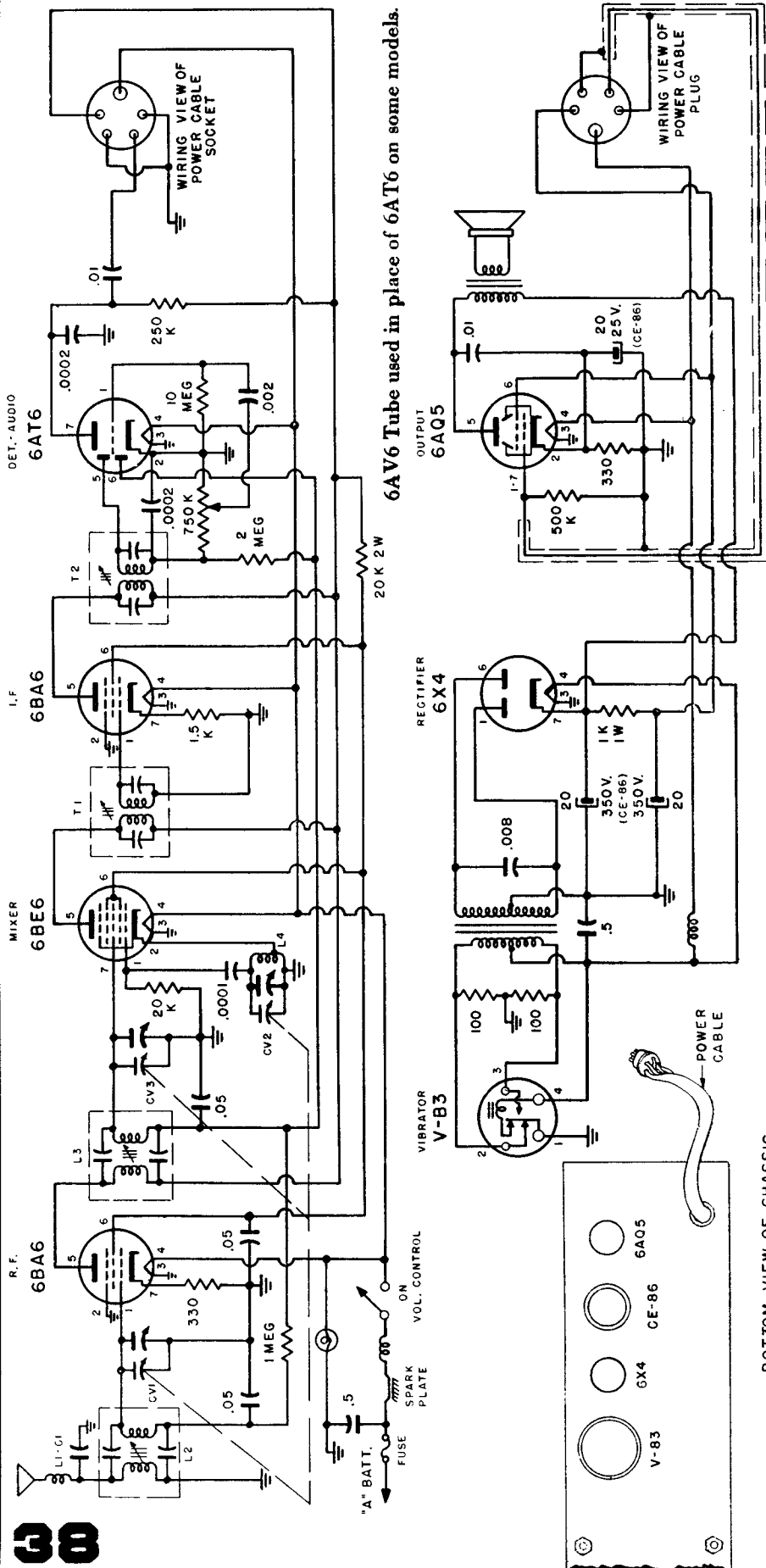

FIRESTONE TIRE & RUBBER

Custom Auto Radios for 1951 Ford, No. 4-B-60; 1949-1950 Ford, 4-B-56; 1950-1951 Studebaker, No. 4-B-62; and 1949-1950 Chevrolet, 4-B-57. The same electrical circuit is used in all these models, but location of parts may differ.

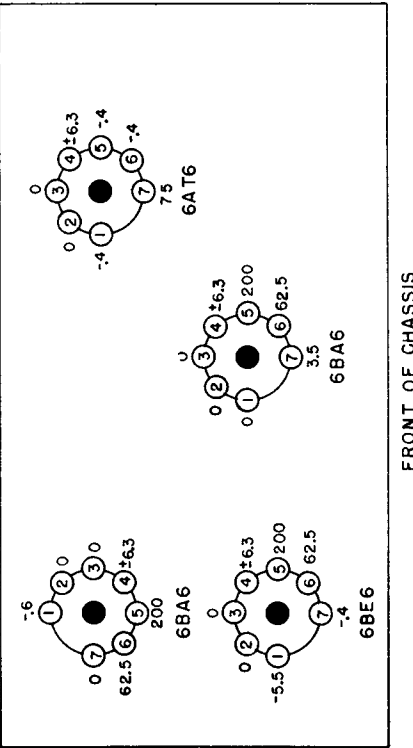
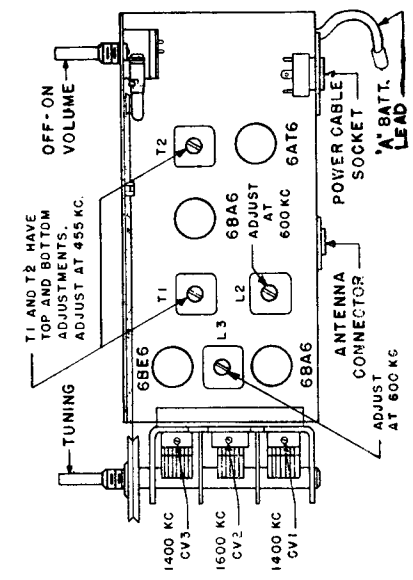

MANUAL OF 1951 MOST-OFTEN-NEEDED RADIO DIAGRAMS

THE FIRESTONE TIRE & RUBBER CO.

Stock No. 4-A-70
Code No. 297-0-299

12AU6
CONVERTER

12AV6
DIODE-AUDIO

50C5
OUTPUT

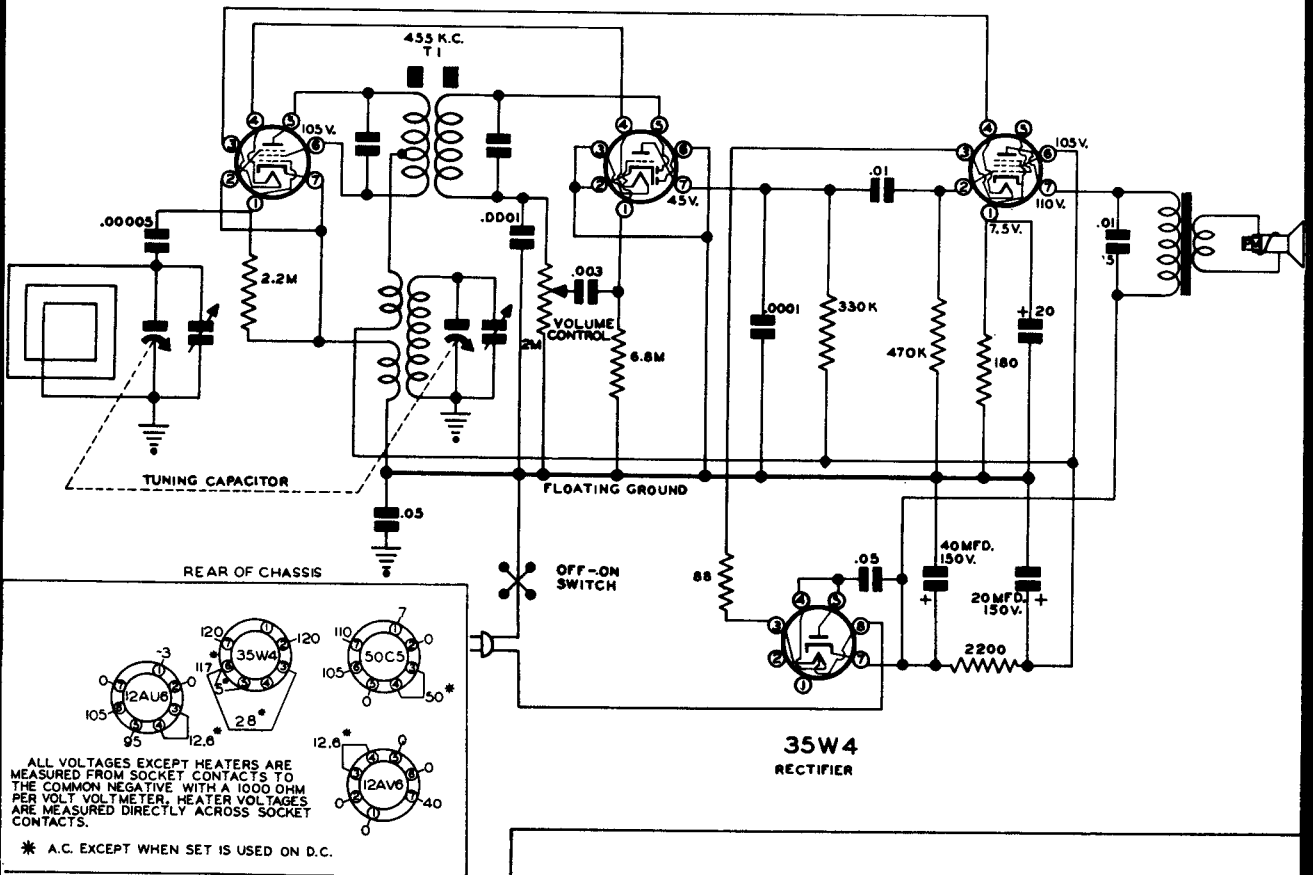

ALL VOLTAGES EXCEPT HEATERS ARE MEASURED FROM SOCKET CONTACTS TO THE COMMON NEGATIVE WITH A 1000 OHM PER VOLT VOLTMETER, HEATER VOLTAGES ARE MEASURED DIRECTLY ACROSS SOCKET CONTACTS.

* A.C. EXCEPT WHEN SET IS USED ON D.C.

VOLTAGE TABLE
(BOTTOM VIEW OF CHASSIS)

Firestone

Stock No. 4-C-18
Code No. 332-0-175193

I. F. Frequency
455 KC

L2 - R.F. COIL

L3 - OSC. COIL

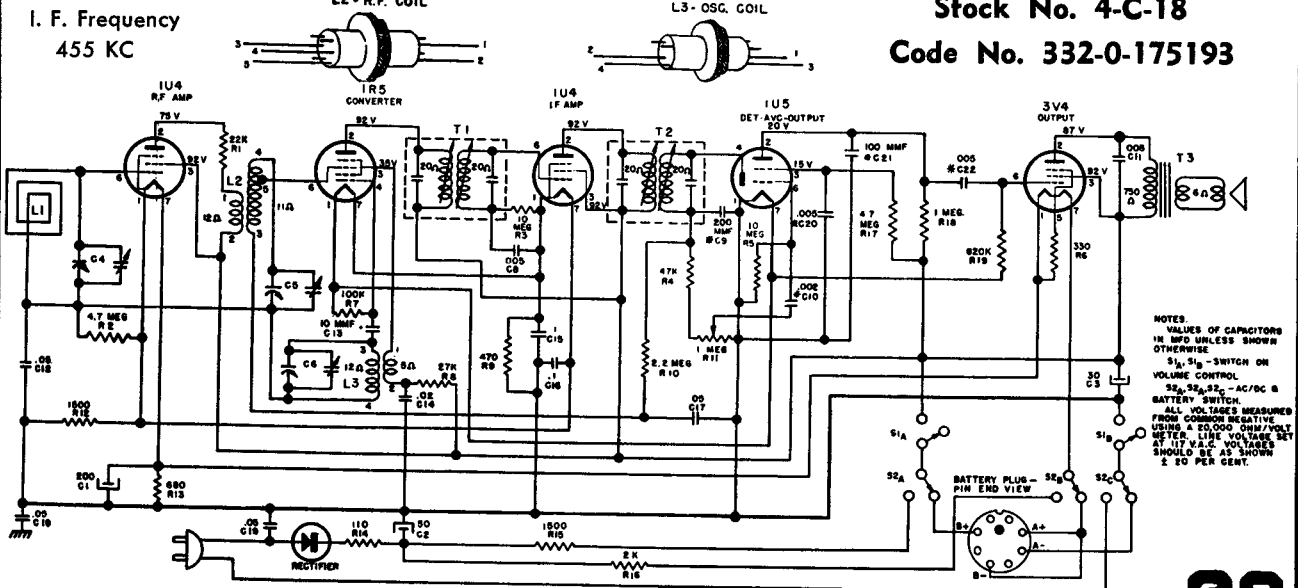

NOTES:
VALUES OF CAPACITORS IN MFD UNLESS SHOWN OTHERWISE
S1_a, S1_b - SWITCH ON VOLUME CONTROL
S2, S2_a, S2_b - AC/DC & BATTERY SWITCH
ALL VOLTAGES MEASURED FROM COMMON NEGATIVE USING A 20,000 OHM/VOLT METER. LINE VOLTAGE SET AT 117 V.A.C. VOLTAGES SHOULD BE AS SHOWN ± 2% PER CENT.

* THESE CAPACITORS ARE IN CERAMIC UNIT PART NUMBER 17-103.

Firestone

CODE NO.
STOCK NO.
STOCK NO.

297-0-3123
4-A-85 Walnut
4-A-89 White

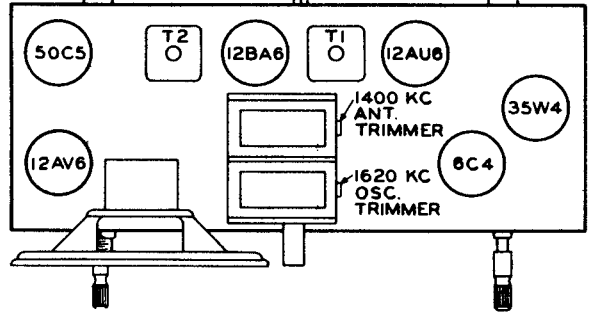
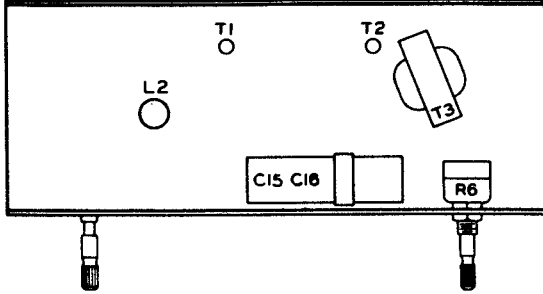
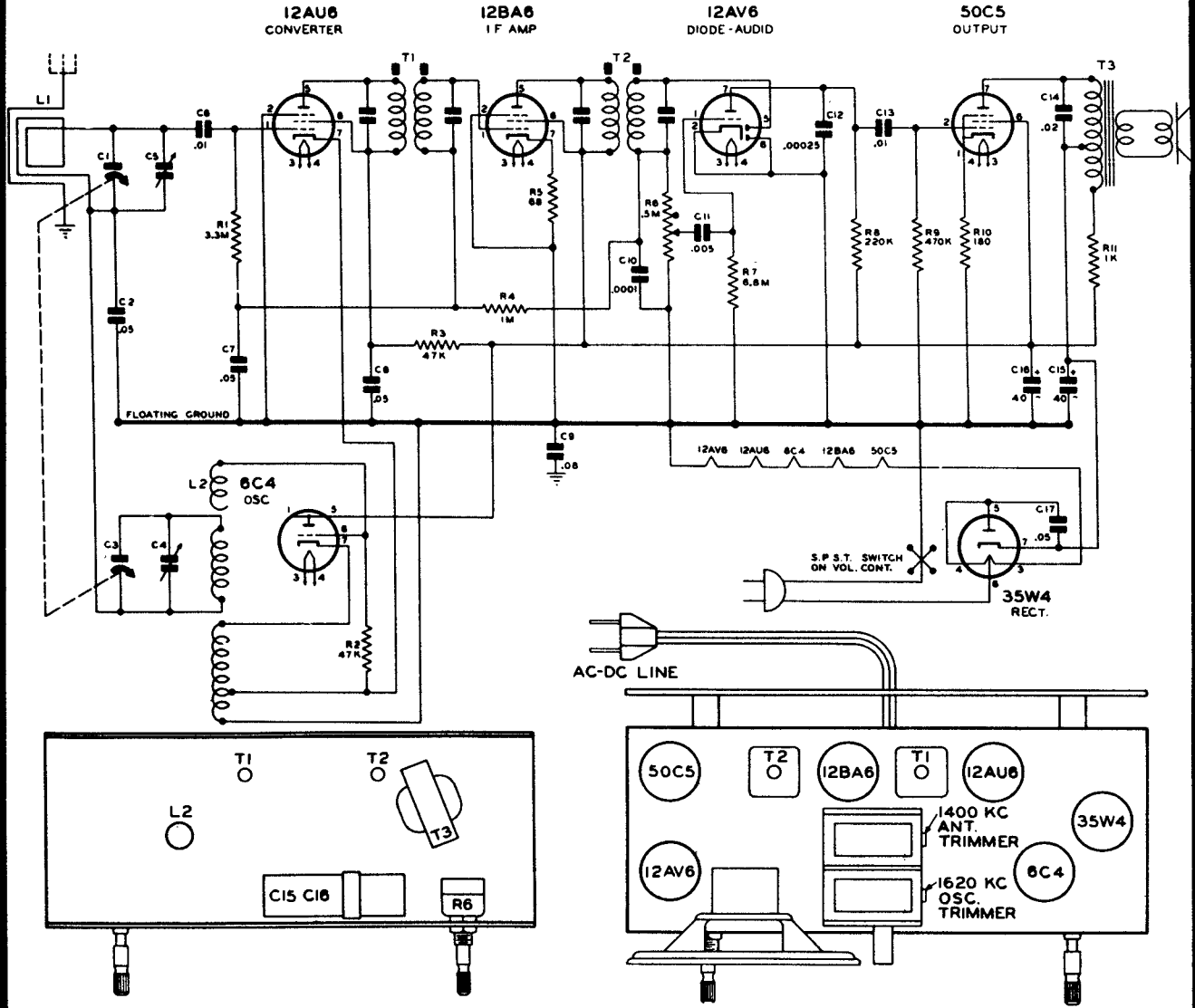

Steps	Set Receiver dial to:	TEST OSCILLATOR		DUMMY ANTENNA	Refer to parts layout diagram for location of trimmers mentioned below:
		Adjust test oscillator frequency to:	Attach output of test oscillator to:		
1	Any point where no interfering signal is received.	EXACTLY 455 KG	High side to grid of 12AU6 Tube. Low side to common negative.	.05 MFD. CONDENSER.	Adjust slugs at top and bottom of 2nd I.F. (T2) and then each of the slugs of the 1st I.F. (T1) for max. output.
2	Exactly 1620 KC	Exactly 1620 KC	External Antenna blue lead on loop.	100 MMFD CONDENSER	Adjust 1620 KC oscillator trimmer for maximum output.
3	Approx. 1400 KC	Approx. 1400 KC	External Antenna blue lead on loop.	100 MMFD CONDENSER	Adjust 1400 KC antenna trimmer for maximum output.

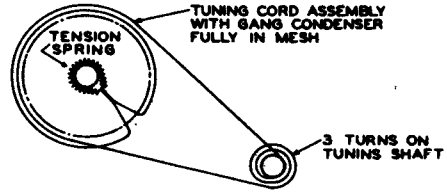
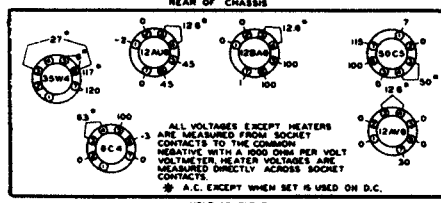

MANUAL OF 1951 MOST-OFTEN-NEEDED RADIO DIAGRAMS

CORONADO RADIO MODEL 05RA33-43-5016A

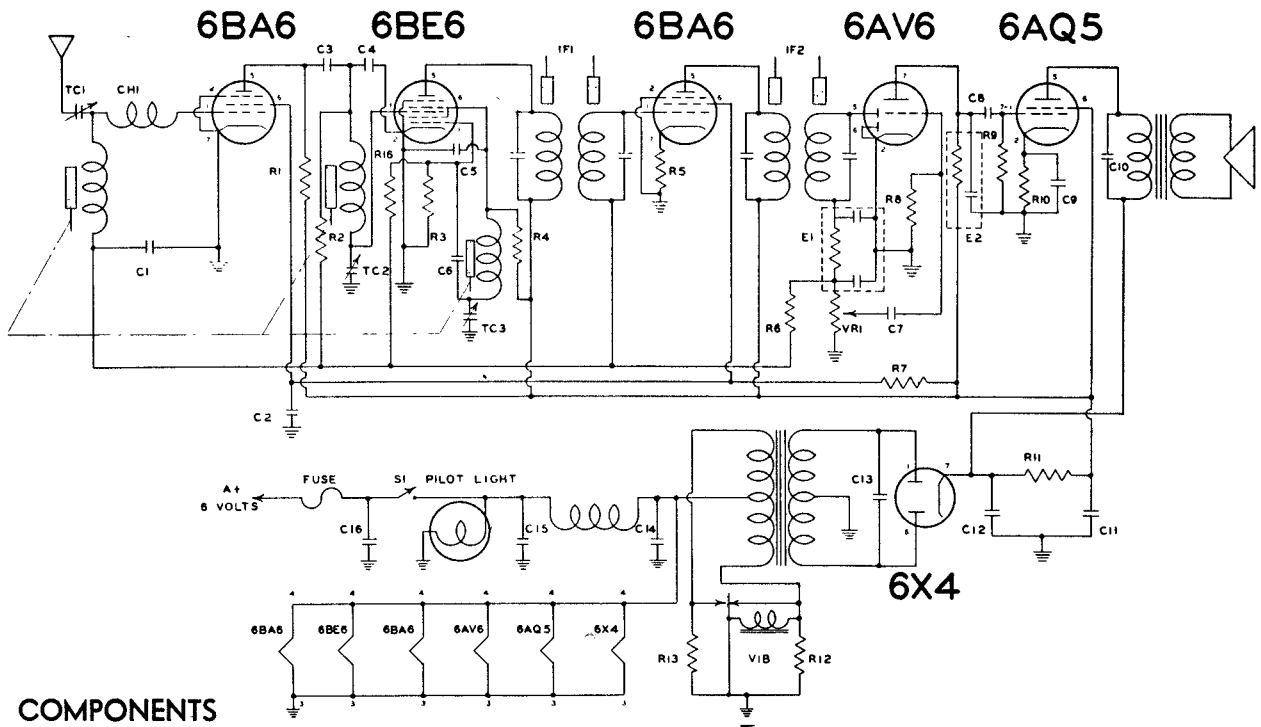

COMPONENTS

SYMBOL	DESCRIPTION	VALUE	RATING
TC2-TC3	Dual Trimmer		
TC1	Trimmer		
C9, C11, C12	Electrolytic	15-15-25 MFD	350-350-25 volts
C14, C15	Generator, capacitor	.5 MFD	
C1	Capacitor, paper	.047 MFD	200 volts
C2	Capacitor, paper	.047 MFD	400 volts
C8	Capacitor, paper	.015 MFD	600 volts
C7, C10	Capacitor, paper	.01 MFD	600 volts
C13	Capacitor, buffer	.0056 MFD	1600 volts
C5	Capacitor, mica	1420 MMFD	500 volts
C4	Capacitor, mica	300 MMFD	500 volts
C6	Capacitor, mica	50 MMFD	500 volts
C3	Capacitor, mica	10 MMFD	500 volts
C16	Capacitor, spark	200 MMFD	2000 volts
R12, R13	Resistor	68 ohms	1/2 watt
R5	Resistor	1200 ohms	1/2 watt
R1, R3	Resistor	22K ohms	1/2 watt
R4	Resistor	33K ohms	1/2 watt
R9	Resistor	470K ohms	1/2 watt
R2	Resistor	1.8 megohm	1/2 watt
R6	Resistor	2.2 megohm	1/2 watt
R8	Resistor	10 megohm	1/2 watt
R10	Resistor	450 ohms	1 watt
R11	Resistor	1000 ohms	1 watt
R7	Resistor	27K ohms	1 watt
VR1	Resistor, suppressor	10K ohms	
S1	Switch SP.S.T.		
E2	Capristor	270K ohm/100 MMFD	
E1	Diode filter unit	100-100 MFD/47K ohm	

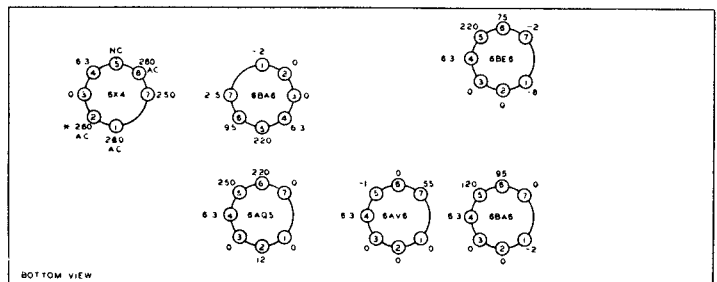
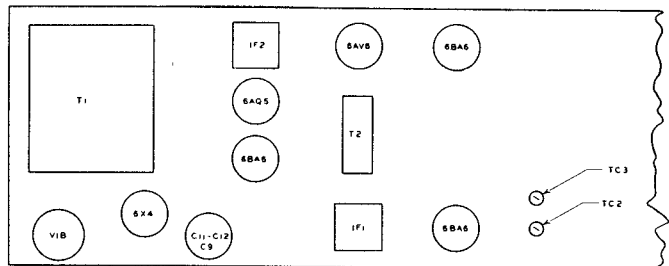

ALIGNMENT PROCEDURE

* TIE POINT FOR C13

VOLTAGE CHART

Frequency	Dummy Antenna	Connection To Radio	Position Of Tuner	Adjust for Max. Output
257.5 KC	100 MMFD	6BE6 Grid Pin No. 7	Slugs Out	IF1 & IF2
1610 KC	100 MMFD	Ant. Jack	Slugs Out	TC3
1610 KC	100 MMFD	Ant. Jack	Slugs Out	TC2
1610 KC	100 MMFD	Ant. Jack	Slugs Out	TC1
1400 KC	100 MMFD	Ant. Jack	Tune in Signal Gen.	LA Slug & LR Slug

MANUAL OF 1951 MOST-OFTEN-NEEDED RADIO DIAGRAMS

CORONADO "BANTAM" RADIO MODEL 05RA33-43-8120A

ALIGNMENT PROCEDURE

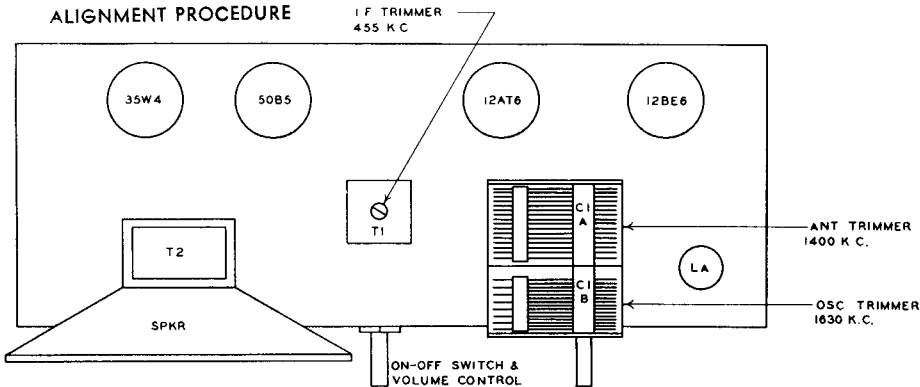

Frequency	Dummy Antenna	Connection to Radio	POSITION OF VARIABLE	ADJUST FOR MAXIMUM OUTPUT
455 KC	100 MMFD	12BE6 Grid Stator C1A	Fully Open	T1
1630 KC	100 MMFD	12BE6 Grid Stator C1A	Fully Open	C1B Oscillator CIA Antenna
1400 KC	100 MMFD	Coupled to Antenna Lead	Fully Open	

Connect low side of signal generator to chassis.

PARTS VALUES FOR T-64 GAMBLE'S AC-DC BANTAM

SYMBOL	DESCRIPTION	VALUE	RATING
C1A-C1B	Condenser, 2 gang	.05 MFD	200 volt
C2, C4	Condenser, paper	5 MMFD	500 volt
C3	Condenser, ceramic	100 MMFD	500 volt
C5	Condenser, mica	.002 MFD	600 volt
C6	Condenser, paper	.005 MFD	600 volt
C7, C8	Condenser, paper	20 MFD	150 volt
C9	Electrolytic	40 MFD	150 volt
C10	Electrolytic	.05 MFD	400 volt
C11	Condenser, paper	22K ohm	1/2 watt
R1	Resistor	2.2 megohm	1/2 watt
R2	Resistor	10 megohm	1/2 watt
R3	Resistor	220K ohm	1/2 watt
R4	Resistor	330K ohm	1/2 watt
R5	Resistor	2200 ohm	1/2 watt
R6	Resistor	68 ohm	1/2 watt
R7	Resistor	1 megohm	2 watt
R8	Volume control		

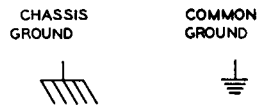
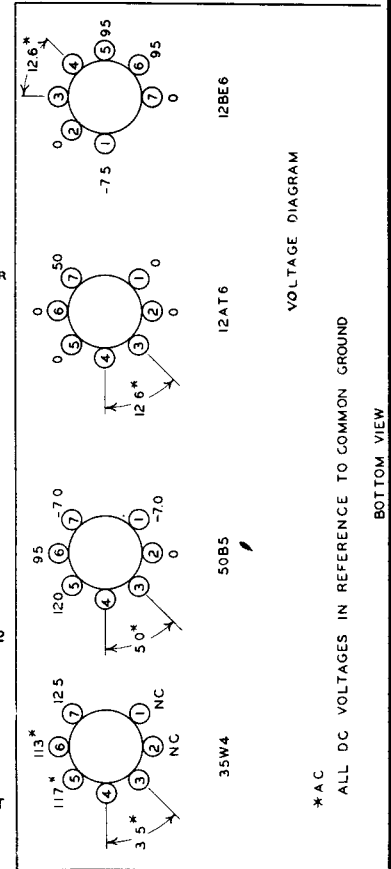
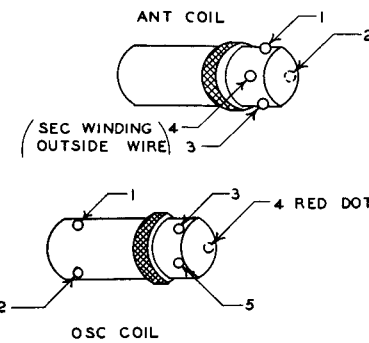

12BE6 12AT6 50B5

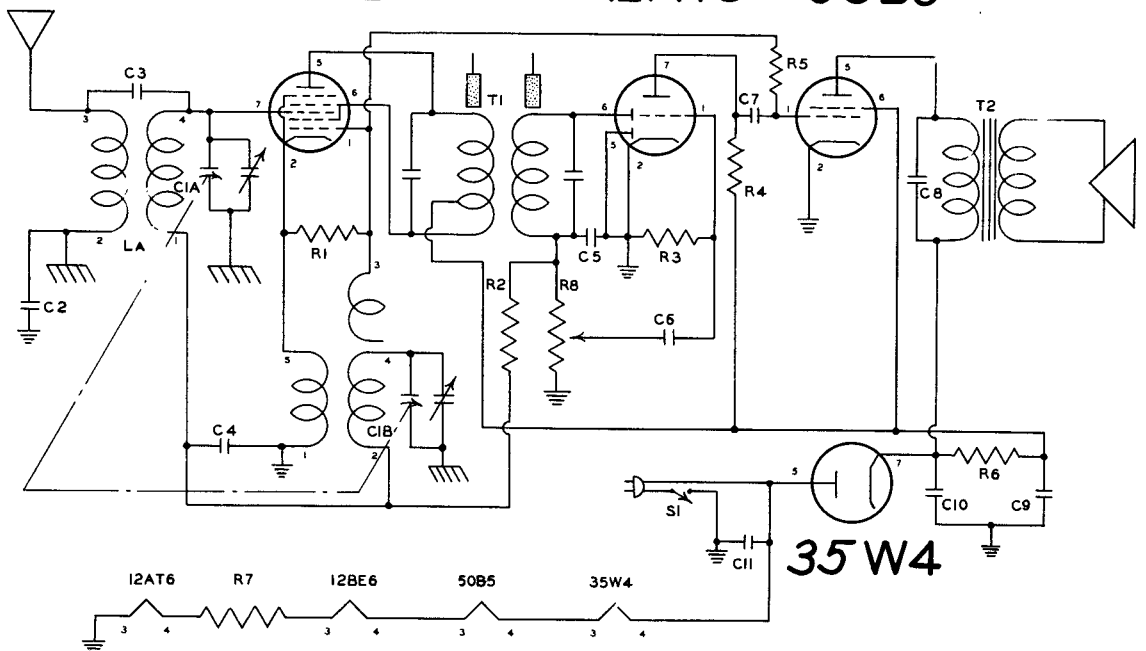

MANUAL OF 1951 MOST-OFTEN-NEEDED RADIO DIAGRAMS

CORONADO RADIO MODEL 05RA4-43-9876A

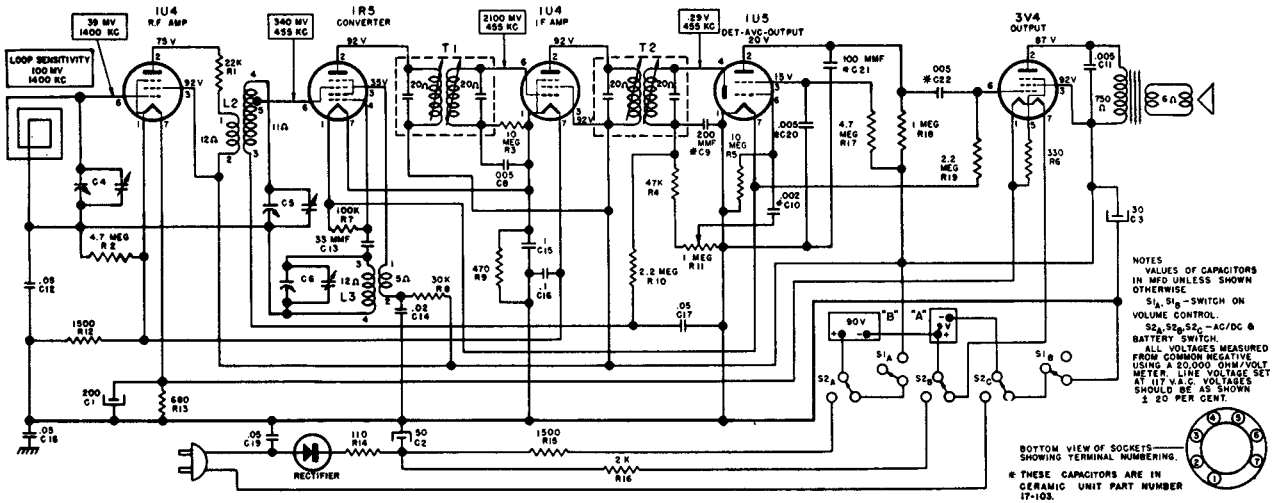

NOTES
 VALUES OF CAPACITORS
 IN MFD UNLESS SHOWN
 OTHERWISE
 S₁, S₂ - SWITCH ON
 VOLUME CONTROL.
 S₂, S₂, S₂ - AC/DC &
 BATTERY SWITCH.
 ALL VOLTAGES MEASURED
 FROM COMMON NEGATIVE
 USING A 20,000 OHM/VOLT
 METER. LINE VOLTAGE SET
 AT 117 V.A.C. VOLTAGES
 SHOULD BE AS SHOWN
 ± 20 PER CENT

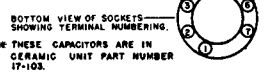

Bottom Chassis View.

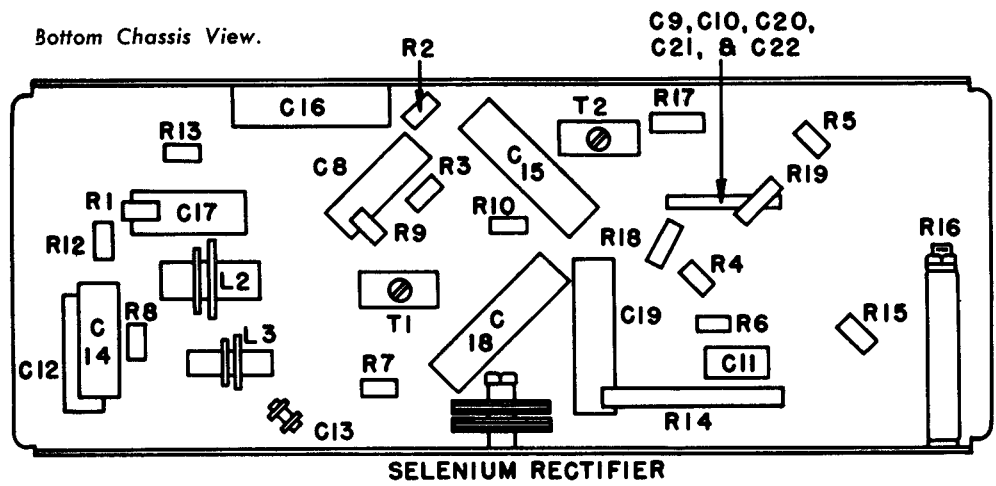

Sets with the
 suffix "B" in-
 stead of "A",
 use 1L4 tubes
 instead of 1U4,
 and a switch
 operated by
 power plug and
 chassis socket.

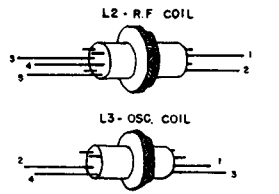

SELENIUM RECTIFIER

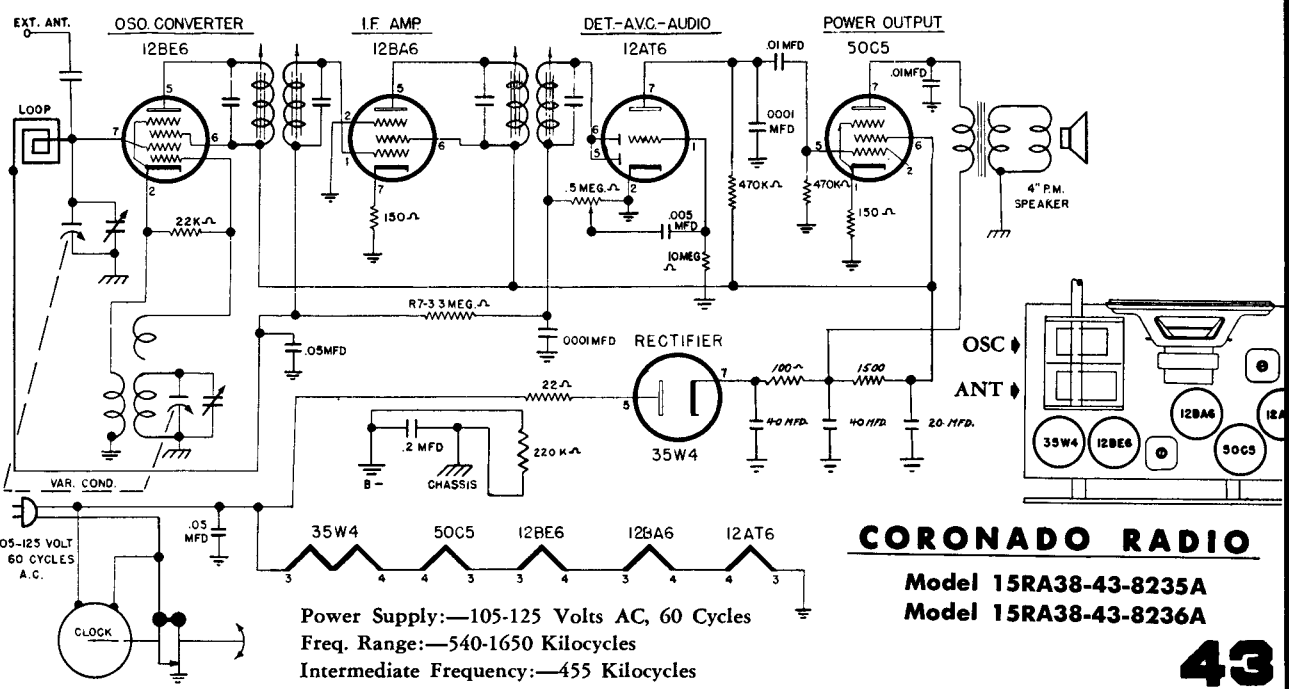

CORONADO RADIO Model 15RA38-43-8235A Model 15RA38-43-8236A

Power Supply:—105-125 Volts AC, 60 Cycles
 Freq. Range:—540-1650 Kilocycles
 Intermediate Frequency:—455 Kilocycles

MANUAL OF 1951 MOST-OFTEN-NEEDED RADIO DIAGRAMS

CORONADO RADIO MODELS 05RA33-43-8136A, 05RA33-43-8137A

HALLICRAFTER RADIO MODELS 5R11, 5R12, 5R13, 5R14

ALIGNMENT PROCEDURE

The alignment should be made with volume control fully on, and the output from the signal generator as low as possible, to prevent AVC action from interfering with proper alignment.

With the output meter connected across the voice coil of the speaker, the output meter reading for 50 milliwatts is 0.4 volts, using a signal which is modulated 400 c.p.s.

Adjust all trimmers for maximum output. Repeat the alignment procedure given below as a final check.

CAUTION: This is an AC/DC receiver, and when aligning the set it is necessary to isolate the signal generator or the receiver from the line by use of a transformer, or to place a .2 MFD condenser in each test lead of the signal generator.

Frequency	SIGNAL GENERATOR Dummy Antenna	Connection to Radio	POSITION OF VARIABLE	ADJUST FOR MAXIMUM OUTPUT
455 KC	.1 MFD	12BE6 Grid Stator VCA	Fully Open	T1 & T2
1625 KC		12BE6 Grid Stator VCA	Fully Open	VCB Oscillator
1400 KC	.1 MFD	Loosely Coupled to Loop	Tune in Signal Generator	VCA Antenna

Connect low side of signal generator to common negative.

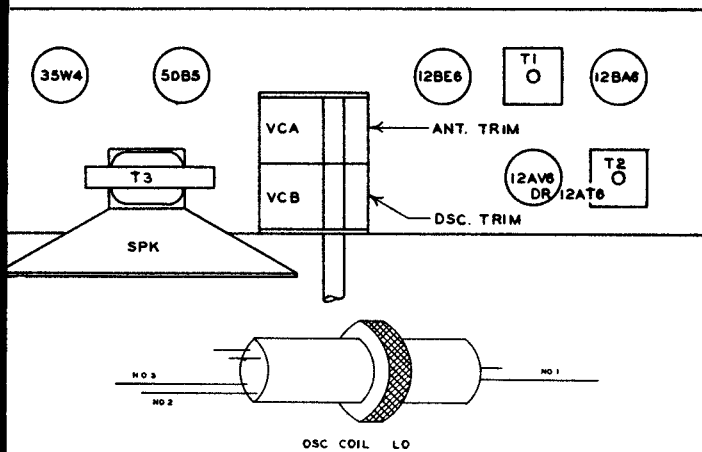

SYMBOL

SYMBOL	DESCRIPTION	VALUE	RATING
VCA-VCB	Condenser, 2 gang		
C1	Condenser, paper	.05 MFD	200 volts
C2	Condenser, paper	.1 MFD	200 volts
C3	Condenser, paper	.02 MFD	600 volts
C4-C6-C7	Condenser, paper	.005 MFD	600 volts
C5	Condenser, mica	250 MMFD	500 volts
C8	Condenser, electrolytic	20 MFD	150 volts
C9	Condenser, electrolytic	40 MFD	150 volts
C10	Condenser, paper	.05 MFD	400 volts
R1	Resistor	22K ohm	1/2 watt
R2	Resistor	390 ohm	1/2 watt
R3	Resistor	1 megohm	1/2 watt
R4	Resistor	10 megohm	1/2 watt
R5-R9	Resistor	470K ohm	1/2 watt
R6	Resistor	120 ohm	1/2 watt
R7	Resistor	10K ohm	1 watt
R8	Resistor	1000 ohm	1 watt
E1	Diode filter unit	2X100 MMFD-47K ohm	
VR	Volume control	1 megohm	

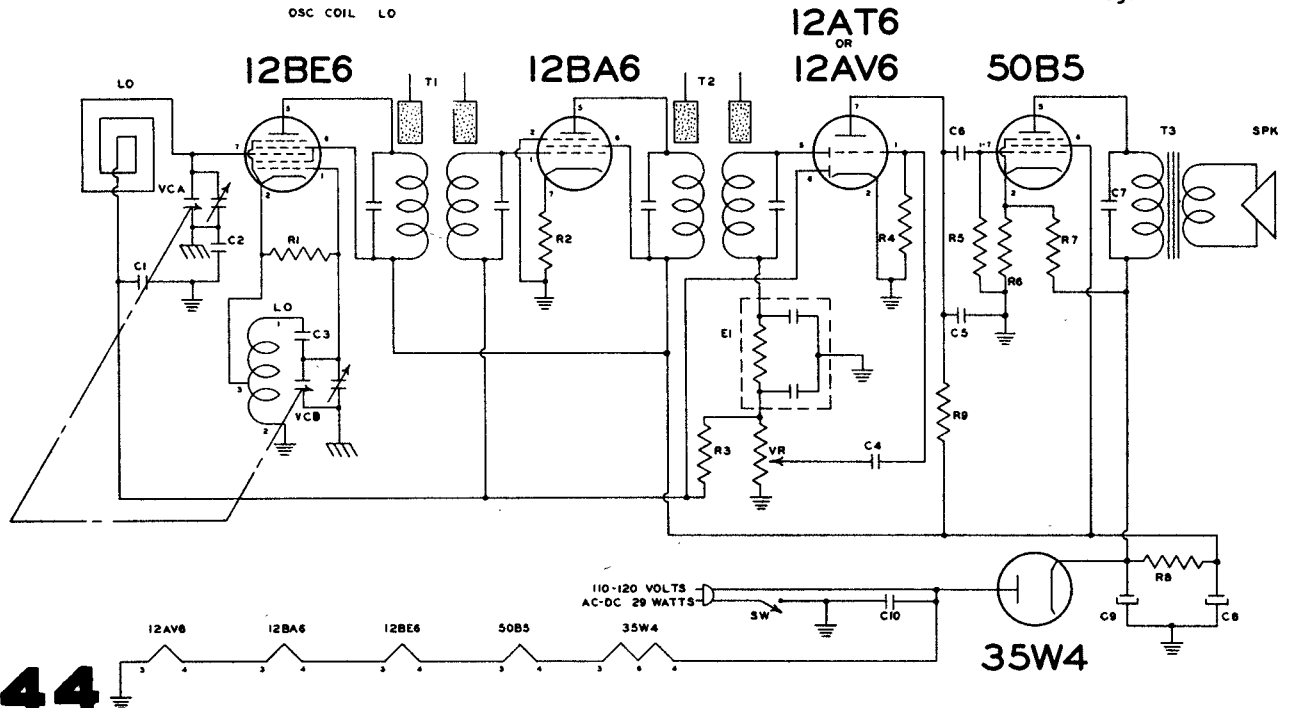

MANUAL OF 1951 MOST-OFTEN-NEEDED RADIO DIAGRAMS

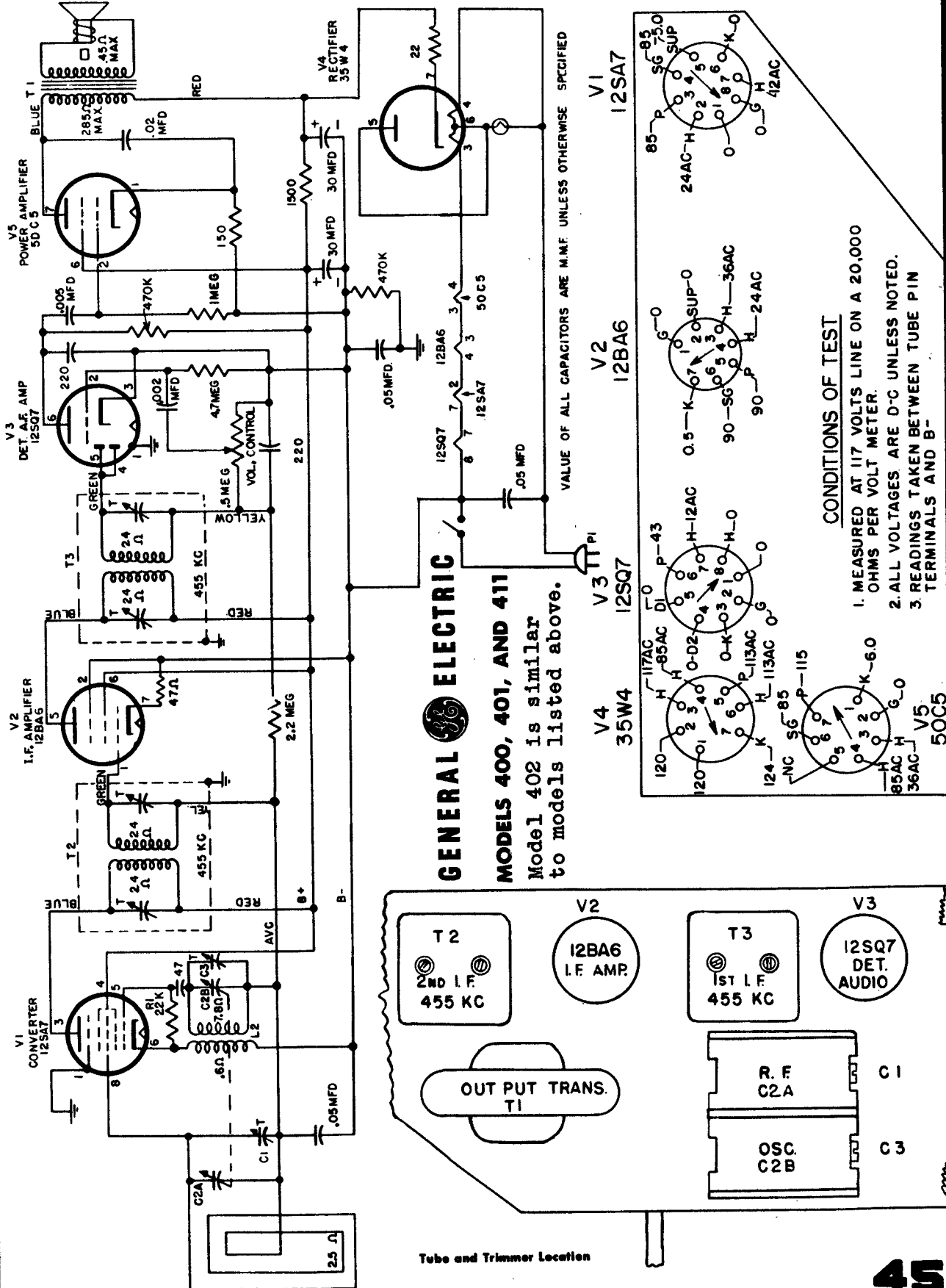

MANUAL OF 1951 MOST-OFTEN-NEEDED RADIO DIAGRAMS

GENERAL ELECTRIC

RADIO SERVICE DATA

MODELS 404, 405 and 410

ALIGNMENT CHART

Step	Connect Test Oscillator to:	Test Osc. Setting	Radio Dial Setting	Adjust Trimmers for Maximum
------	-----------------------------	-------------------	--------------------	-----------------------------

I-F ALIGNMENT

1	V3, 12BA6 grid (Pin 1), in series with 0.5 mfd.	455 KC	C9 and C8 of second i-f transformer T3.
2	V2, 12SA7 grid (Pin 8), in series with .05 mfd.			C7 and C6 of first i-f transformer, T2
3				Recheck adjustment of C9, C8, C7, C6, for maximum

R-F ALIGNMENT

4	Inductively coupled to radio loop.	1620 KC	Minimum capacity C1A, C1B	C3, oscillator trimmer
5		1500 KC	Tune for Maximum	C1, r-f trimmer C2, ant. trimmer

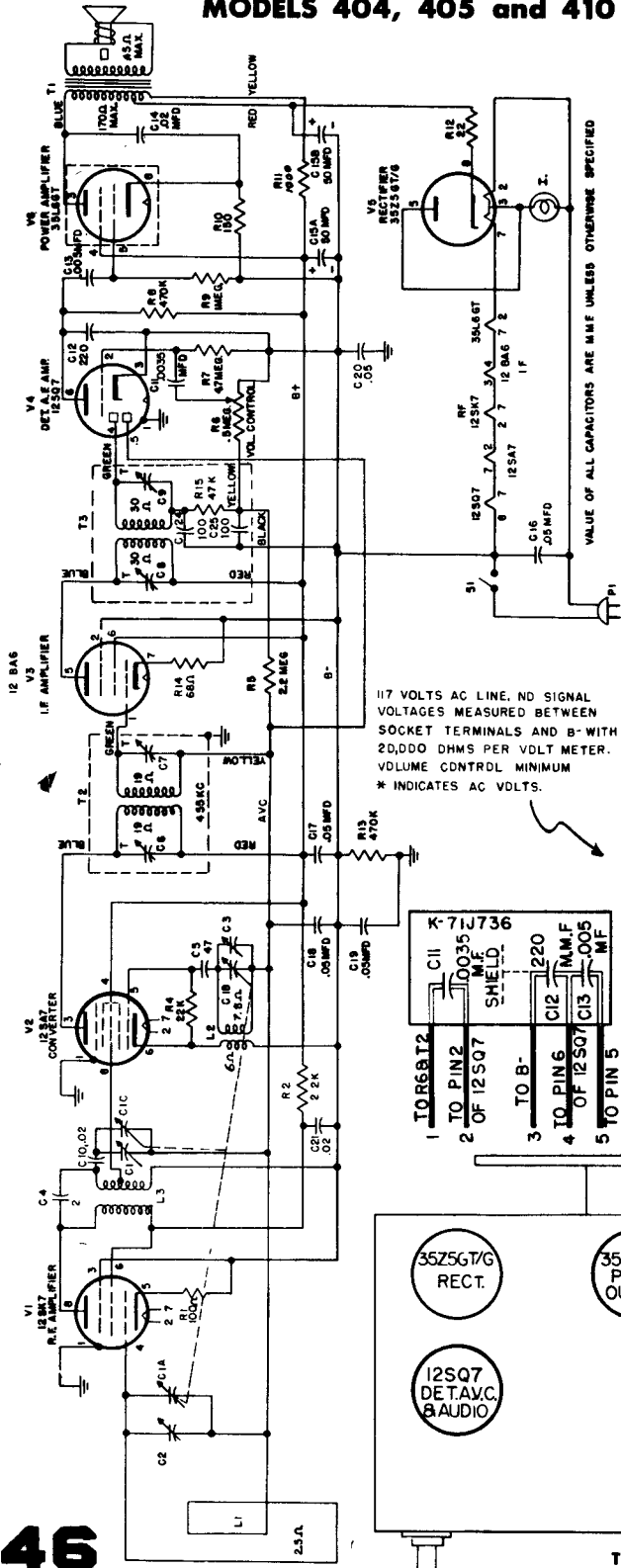

FRONT OF CHASSIS

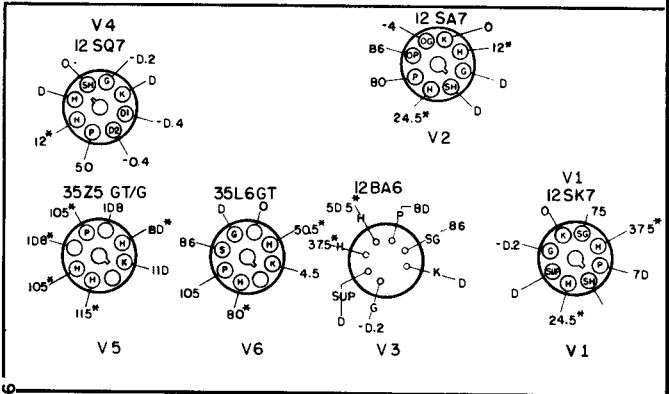

BOTTOM VIEW OF CHASSIS

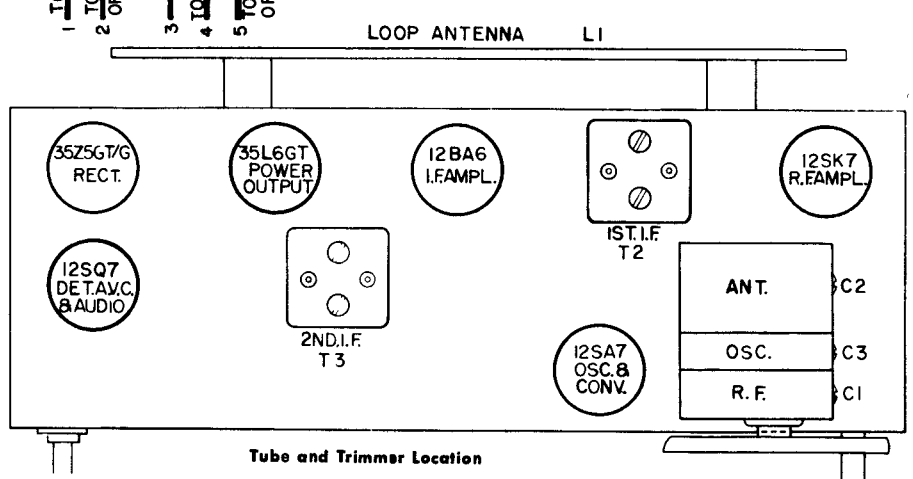

Tube and Trimmer Location

MANUAL OF 1951 MOST-OFTEN-NEEDED RADIO DIAGRAMS

GENERAL ELECTRIC

MODEL 408

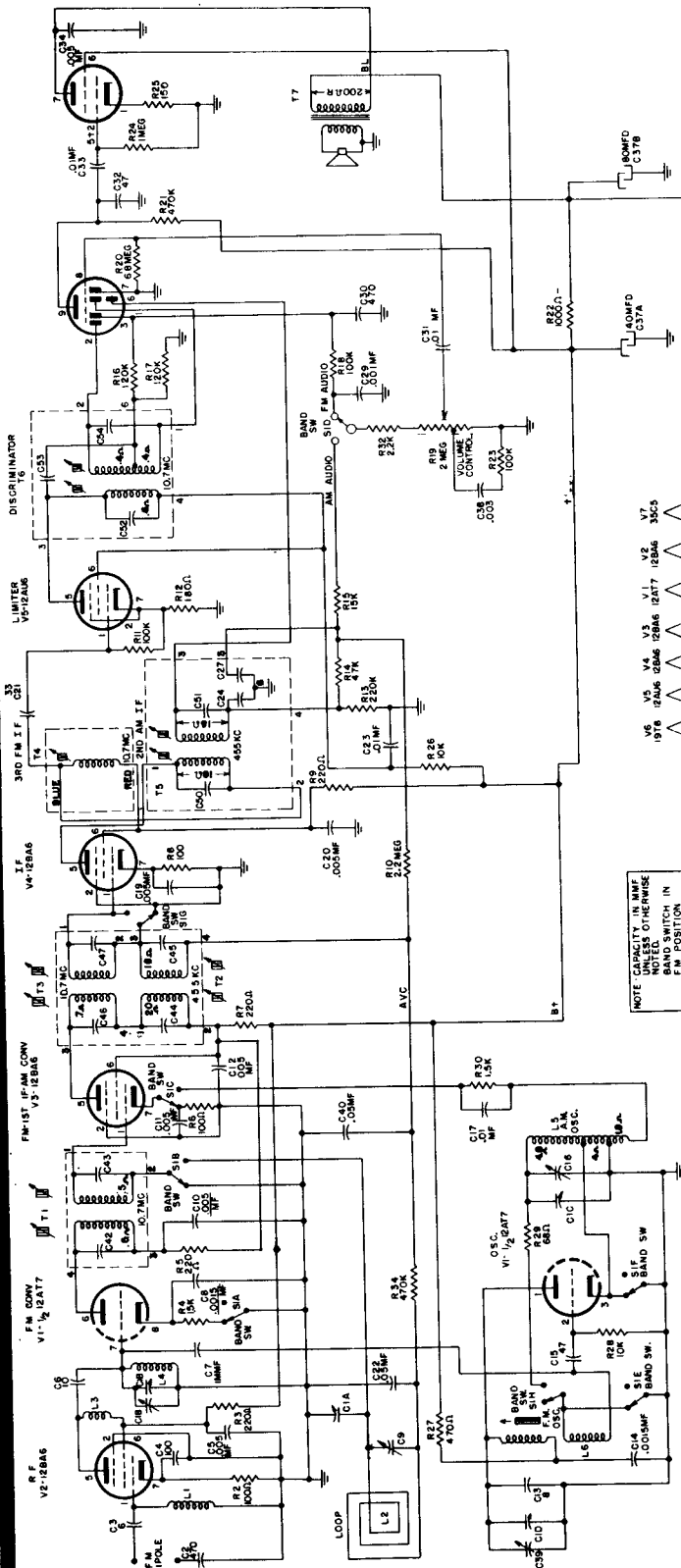

NOTE CAPACITANCE VALUES NOTED. BAND SWITCH IN F.M. POSITION.

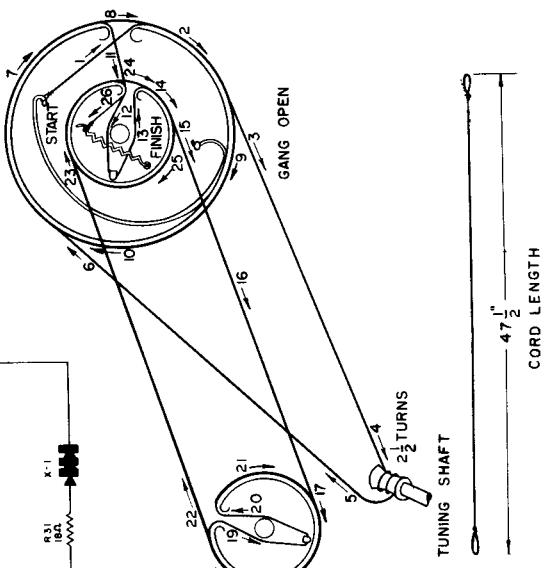

BROADCAST ANTENNA TRIMMER

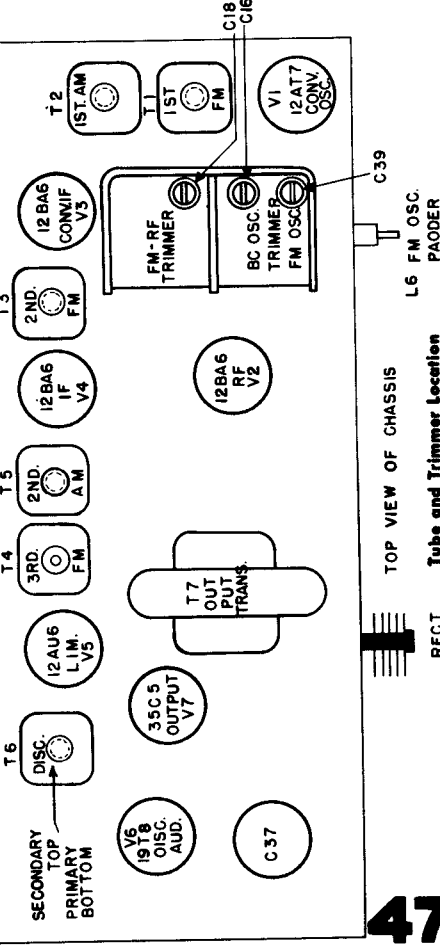

MANUAL OF 1951 MOST-OFTEN-NEEDED RADIO DIAGRAMS

GENERAL ELECTRIC

MODELS 510F, 511F, 512F, 513F, 515F, 516F, 517F, 518F, 521F, AND 522F

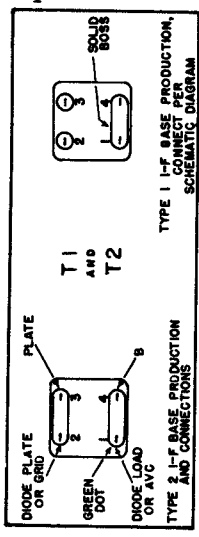
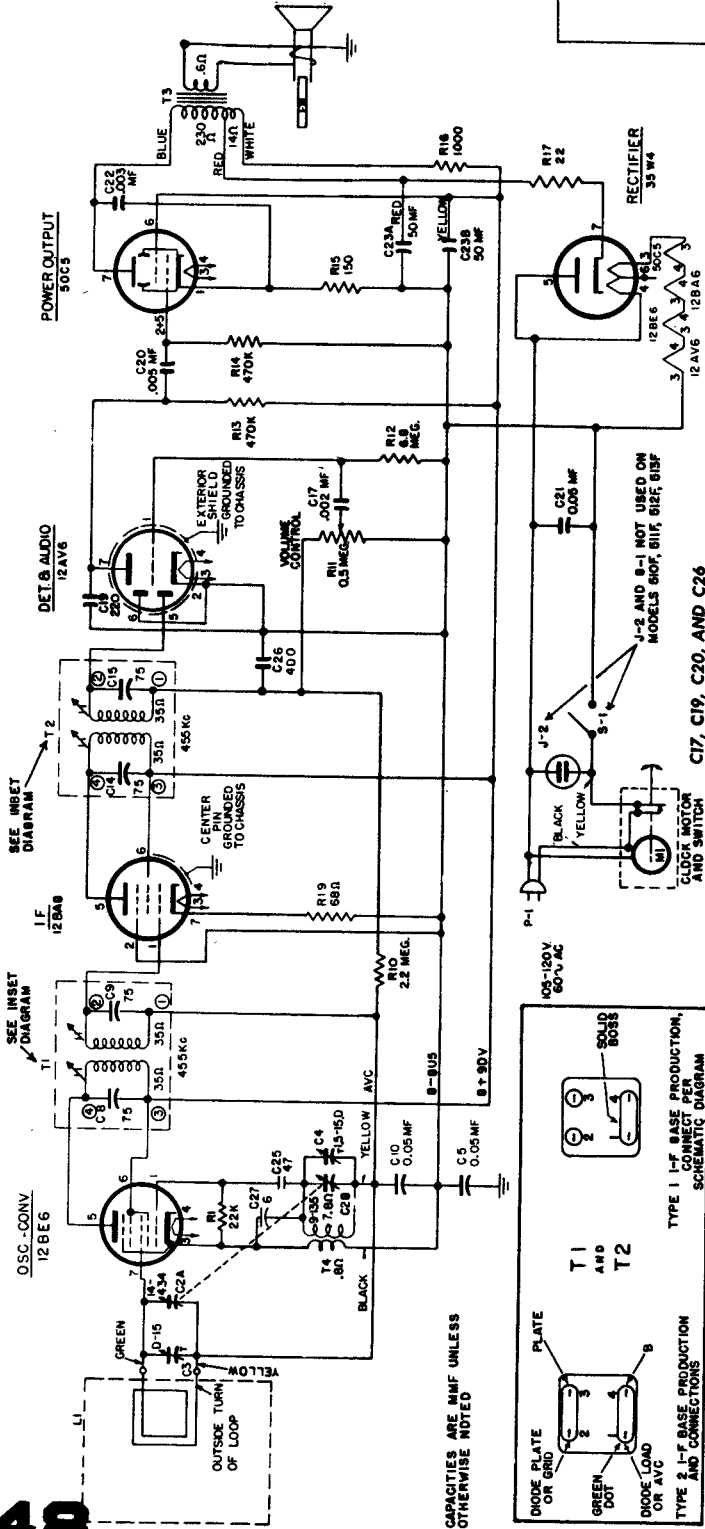

TYPE 1 1-1/2 BASE PRODUCTION, AND CONNECTIONS

TYPE 2 1-1/2 BASE PRODUCTION, AND CONNECTIONS

CAPACITIES ARE MMF UNLESS OTHERWISE NOTED

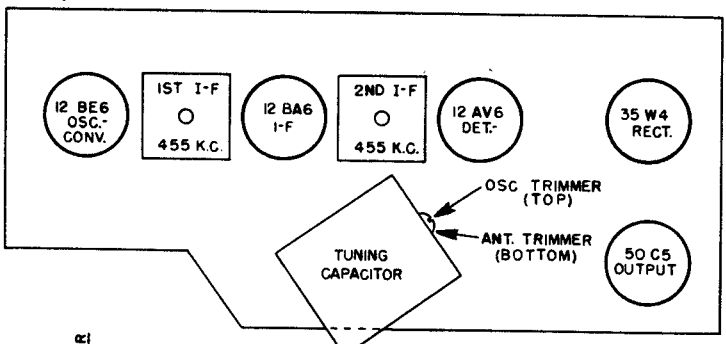

The lead identification for the four-section ceramic capacitor RCW-3048 (K71J670) can be observed from the illustration of Figure 2.

C17, C19, C20, AND C26

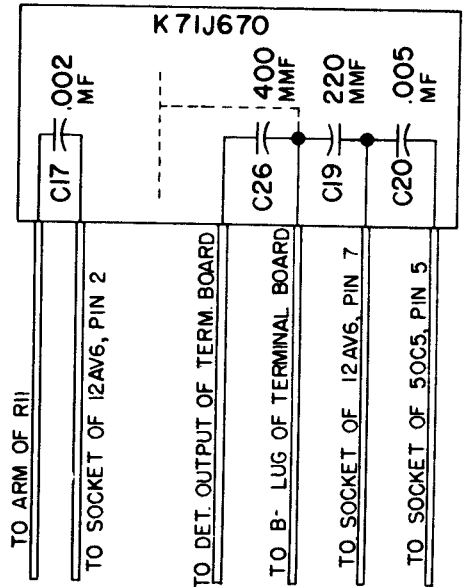

Capacitor RCW-3013

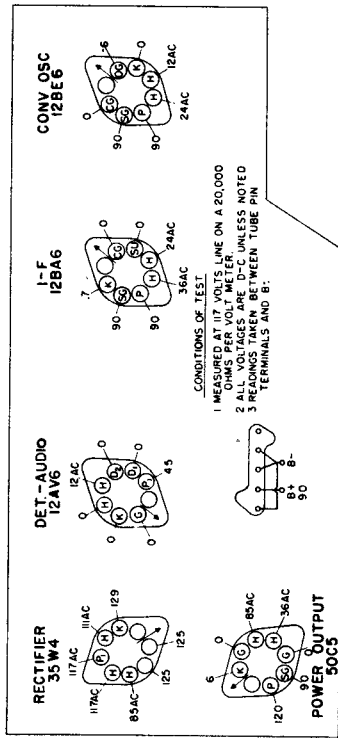

CONDITIONS OF TEST

- 1 MEASURED AT 117 VOLTS LINE ON A 20,000 OHMS PER VOLT METER
- 2 ALL READINGS TAKEN BETWEEN TUBE PIN TERMINALS AND B-

VIEWED FROM BOTTOM OF CHASSIS

General Electric models as listed in the upper left hand corner, but without the suffix "F", use an identical circuit but employ 12SA7 instead of 12BE6, and 12SQ7 for 12AV6, and differ in physical assembly.

MANUAL OF 1951 MOST-OFTEN-NEEDED RADIO

GENERAL ELECTRIC

Models 605 and 606

ALIGNMENT CHART

Step	Sig. Gen. Connected to	Sig. Gen. Frequency	Dial Setting	Adjust For Max. Output
1	1T4 Grid Pin 6	455 kc	550 kc	Cores of I-F Trans. T ₃
2	1R5 Grid Pin 6	455 kc	550 kc	Cores of I-F Trans. T ₂
3	1R5 Grid Pin 6	455 kc	550 kc	Re-adjust T ₂ and T ₃
4	Inductively Coupled	1620 kc	1620 kc	Osc. trimmer C2B
5	Inductively Coupled	1500 kc	Tune for maximum	R.F. trimmer C1B

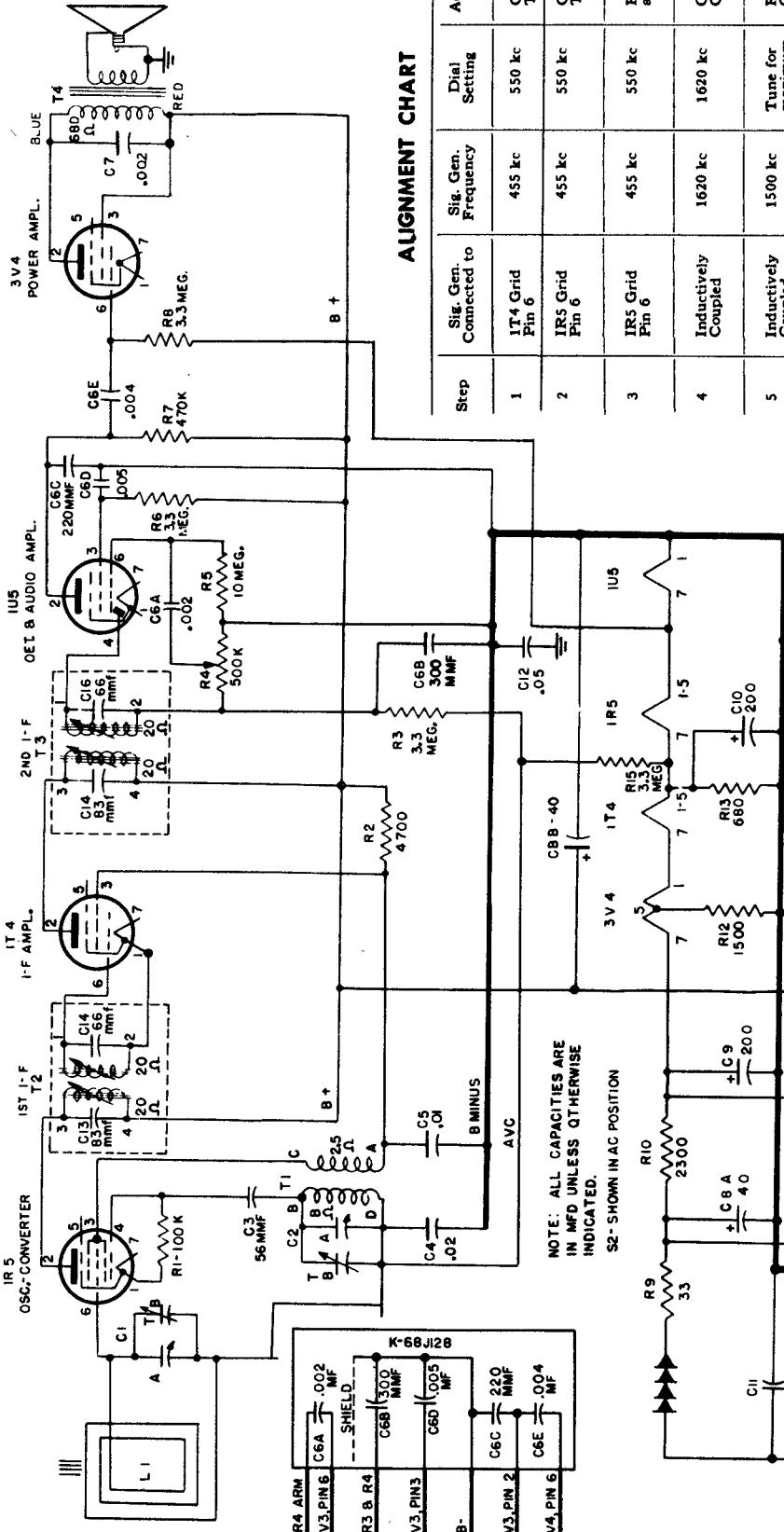

NOTE: ALL CAPACITIES ARE IN MFD UNLESS OTHERWISE INDICATED.
S2 - SHOWN IN AC POSITION

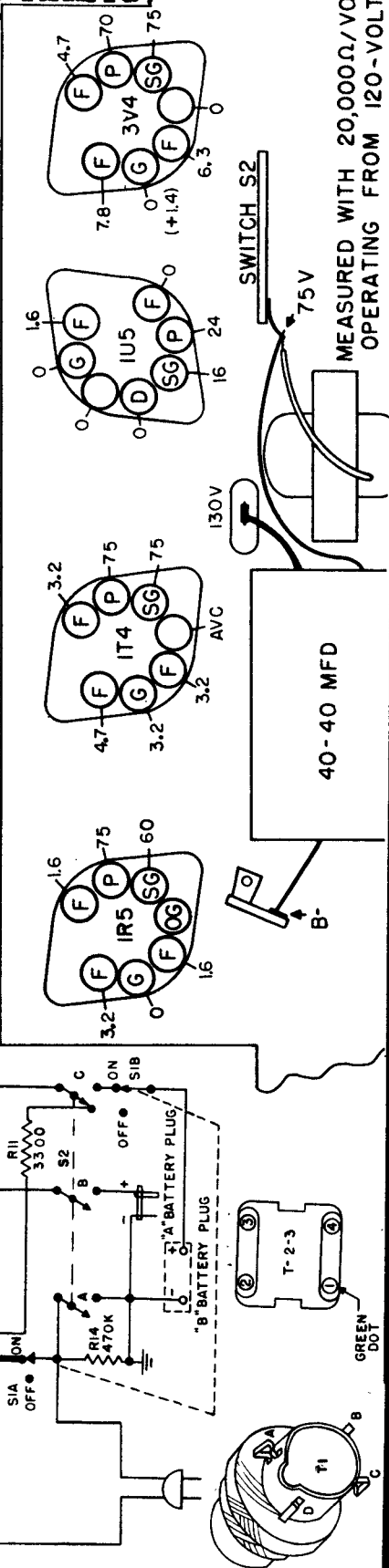

MEASURED WITH 20,000Ω/VOLT
OPERATING FROM 120-VOLTS

MANUAL OF 1951 MOST-OFTEN-NEEDED RADIO DIAGRAMS

GENERAL ELECTRIC MODELS 610 AND 611

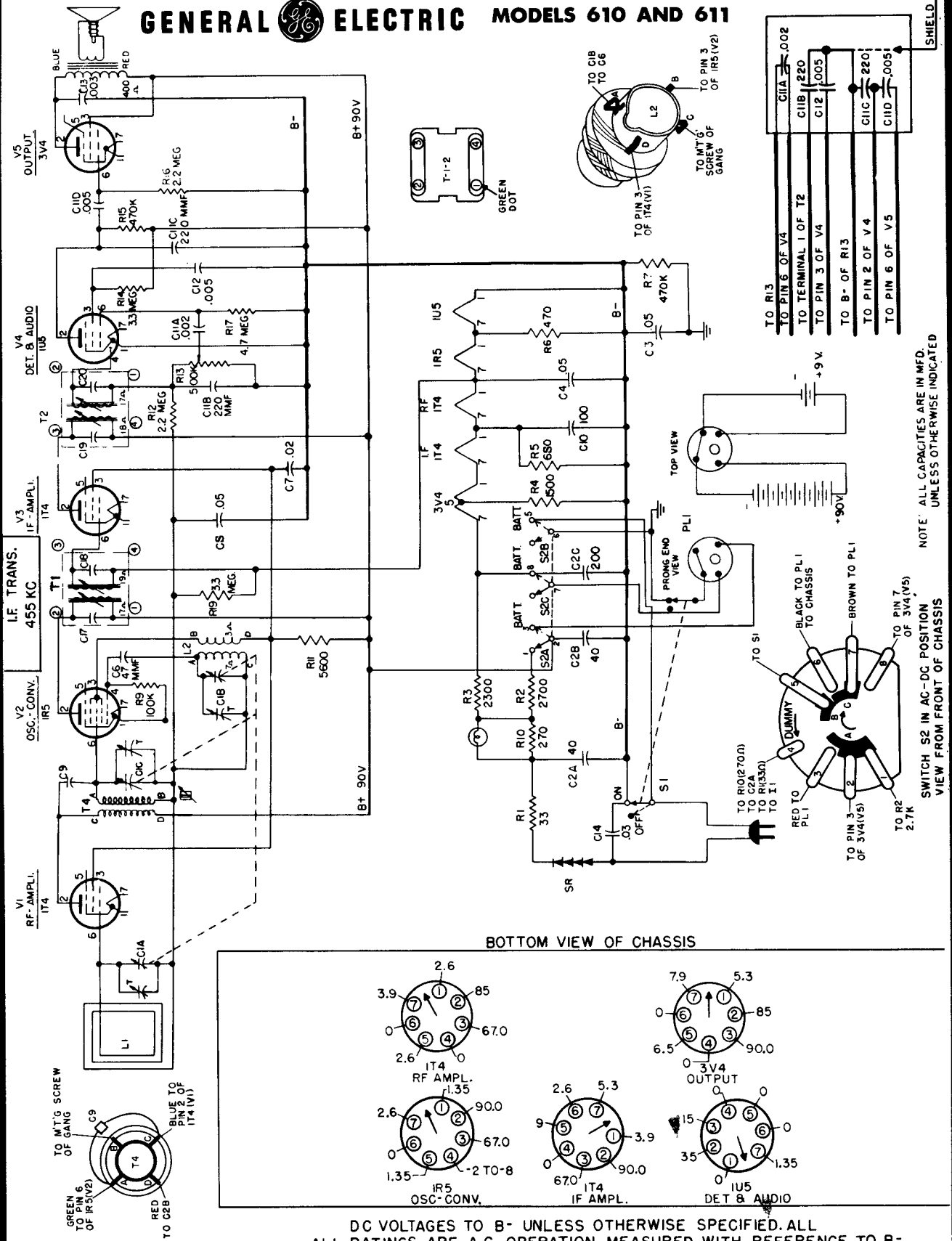

NOTE: ALL CAPACITIES ARE IN MFD. UNLESS OTHERWISE INDICATED.

BOTTOM VIEW OF CHASSIS

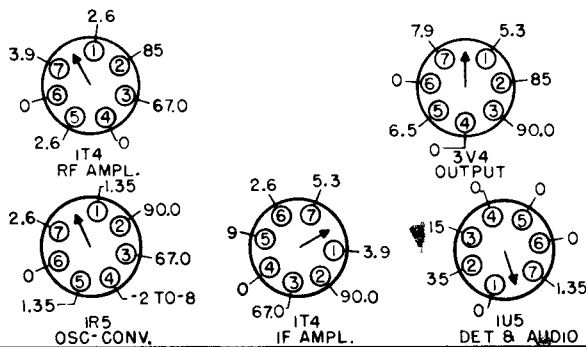

MANUAL OF 1951 MOST-OFTEN-NEEDED RADIO DIAGRAMS

GENERAL ELECTRIC RADIO SERVICE DATA FOR MODEL 740

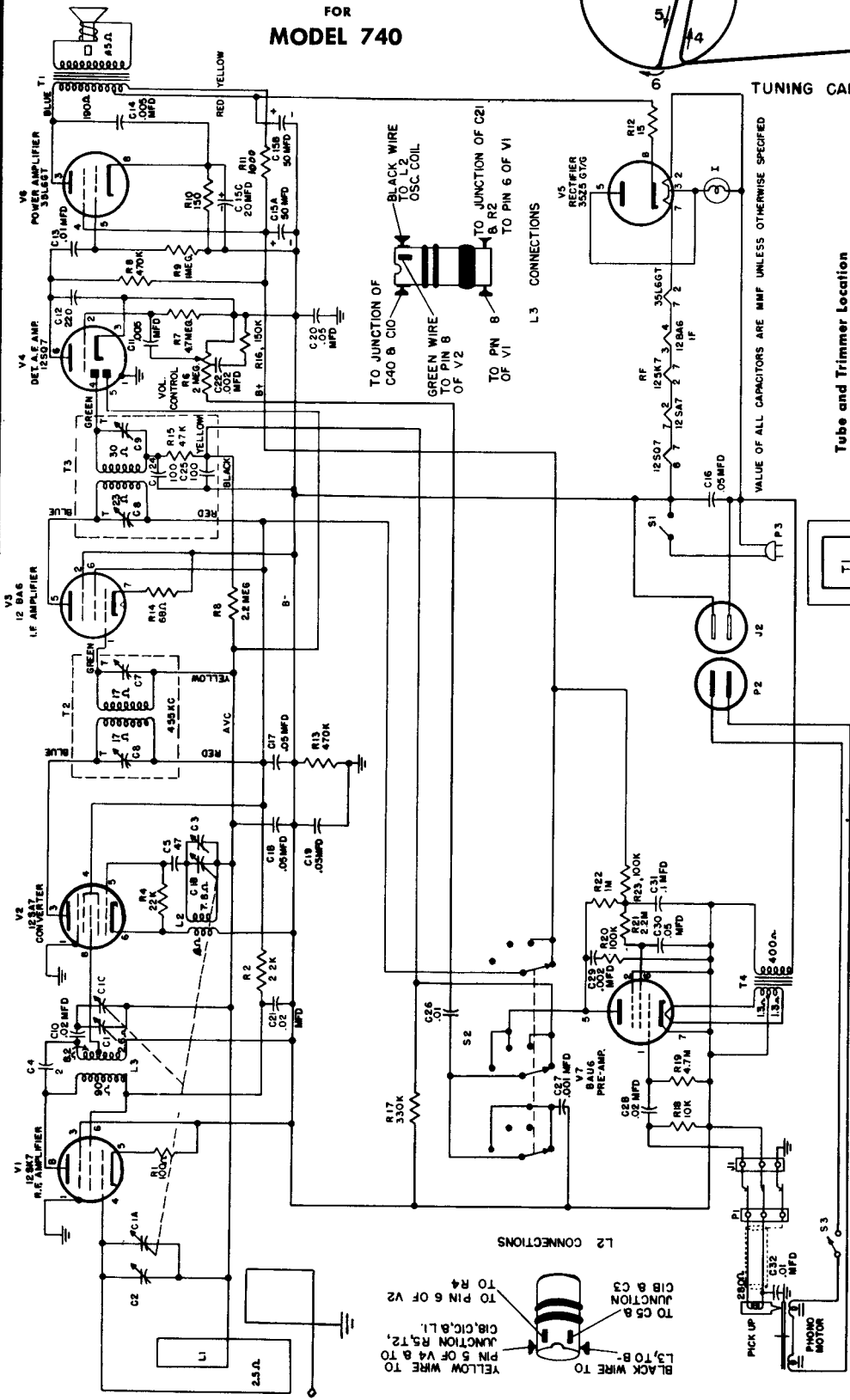
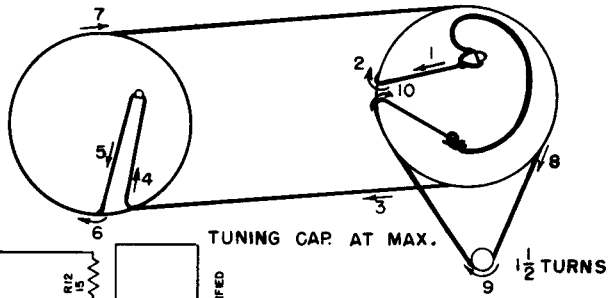

Tube and Trimmer Location

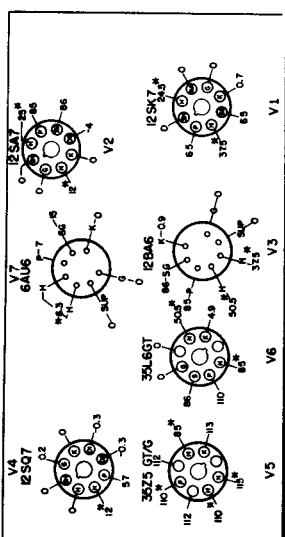
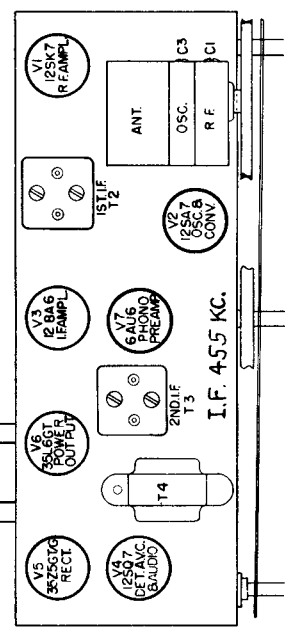

117 VOLTS AC LINE VOLTAGE
NO SIGNAL INPUT
NO SIGNAL SOCKET TERMINALS SHOWN
USE 20,000 OHM PER VOLTS METER
SET VOLUME CONTROL TO MINIMUM
* INDICATES AC FLUORESCENT VOLTAGES
SWITCH SE IN RADIO POSITION

Schematic Change. On later production receivers, the pilot lamp is connected across the secondary of T4 — instead of pins 2-3 of the Type 35Z5 tube (V5). Pin 5 of this tube is connected to pin 2 instead of pin 3.

MANUAL OF 1951 MOST-OFTEN-NEEDED RADIO DIAGRAMS

GENERAL ELECTRIC

MODELS 752-753

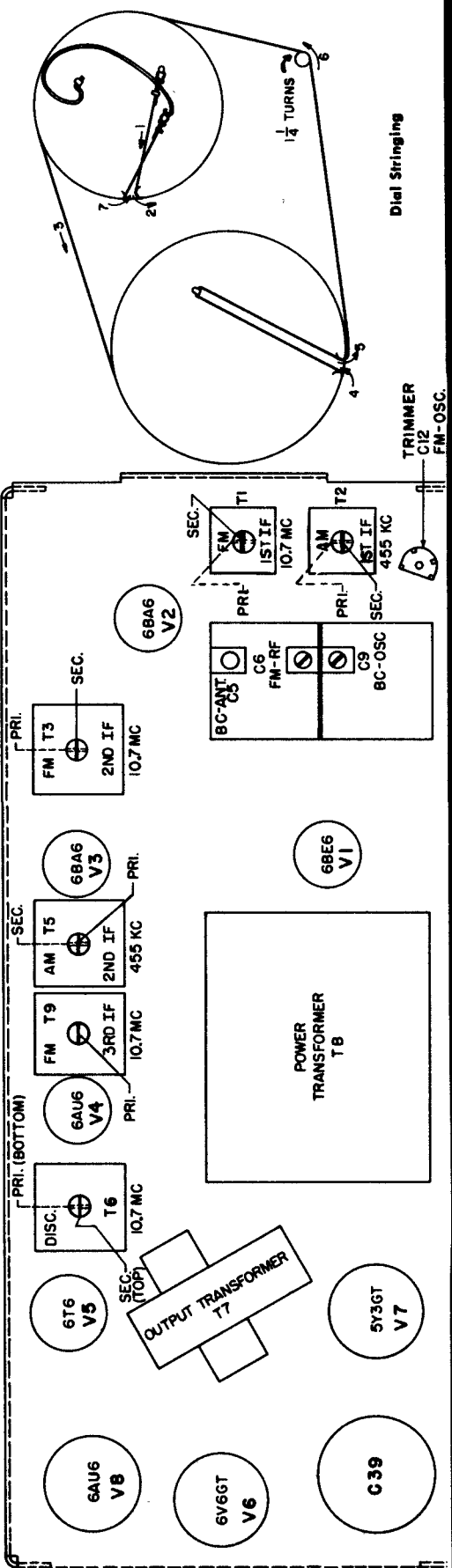
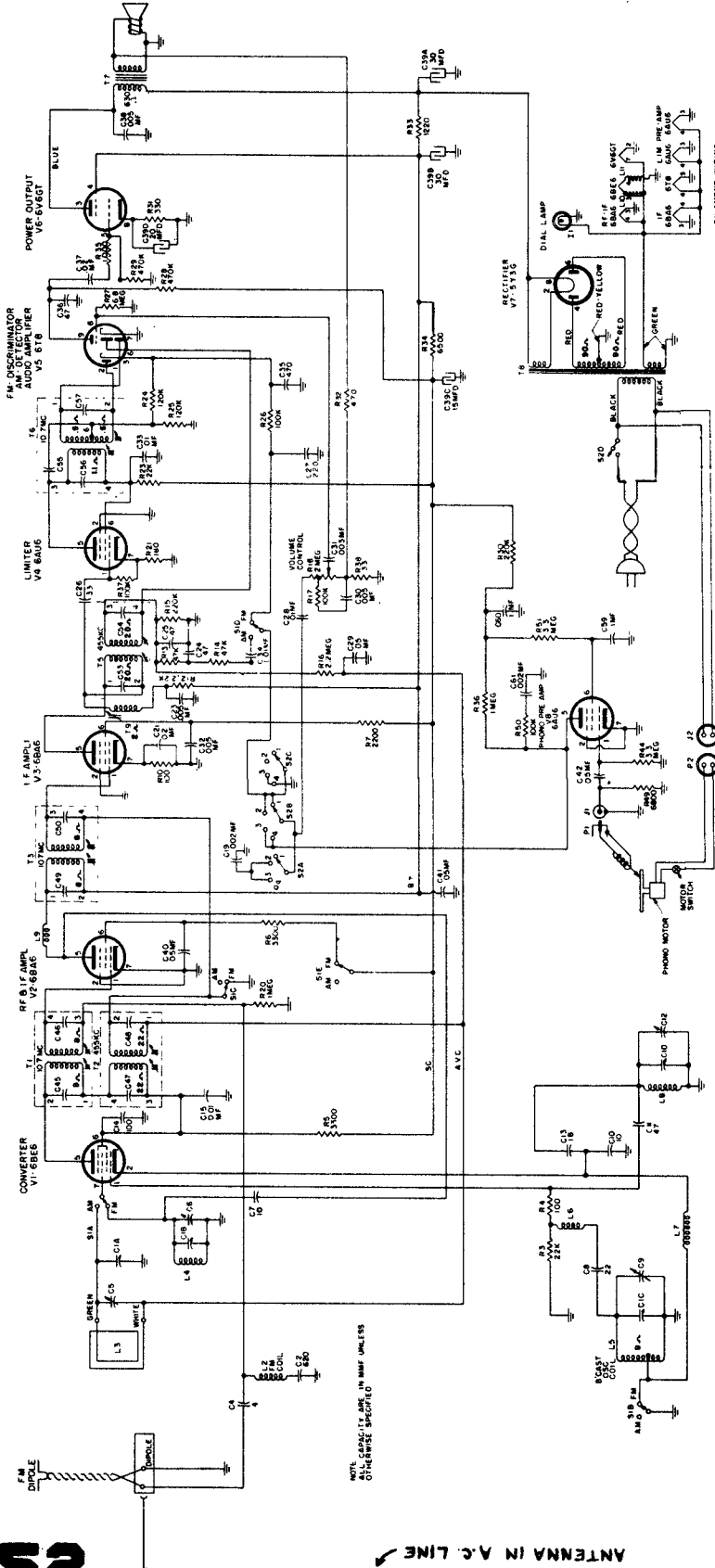

The Hallicrafters Co.
Model 5R10 Radio Receiver

CONVERTER
V₁
12SA7

IF AMPLIFIER
V₂
12SK7

DETECTOR &
1ST AUDIO AMP.
V₃
12SO7

AUDIO OUTPUT
V₄
50L6GT

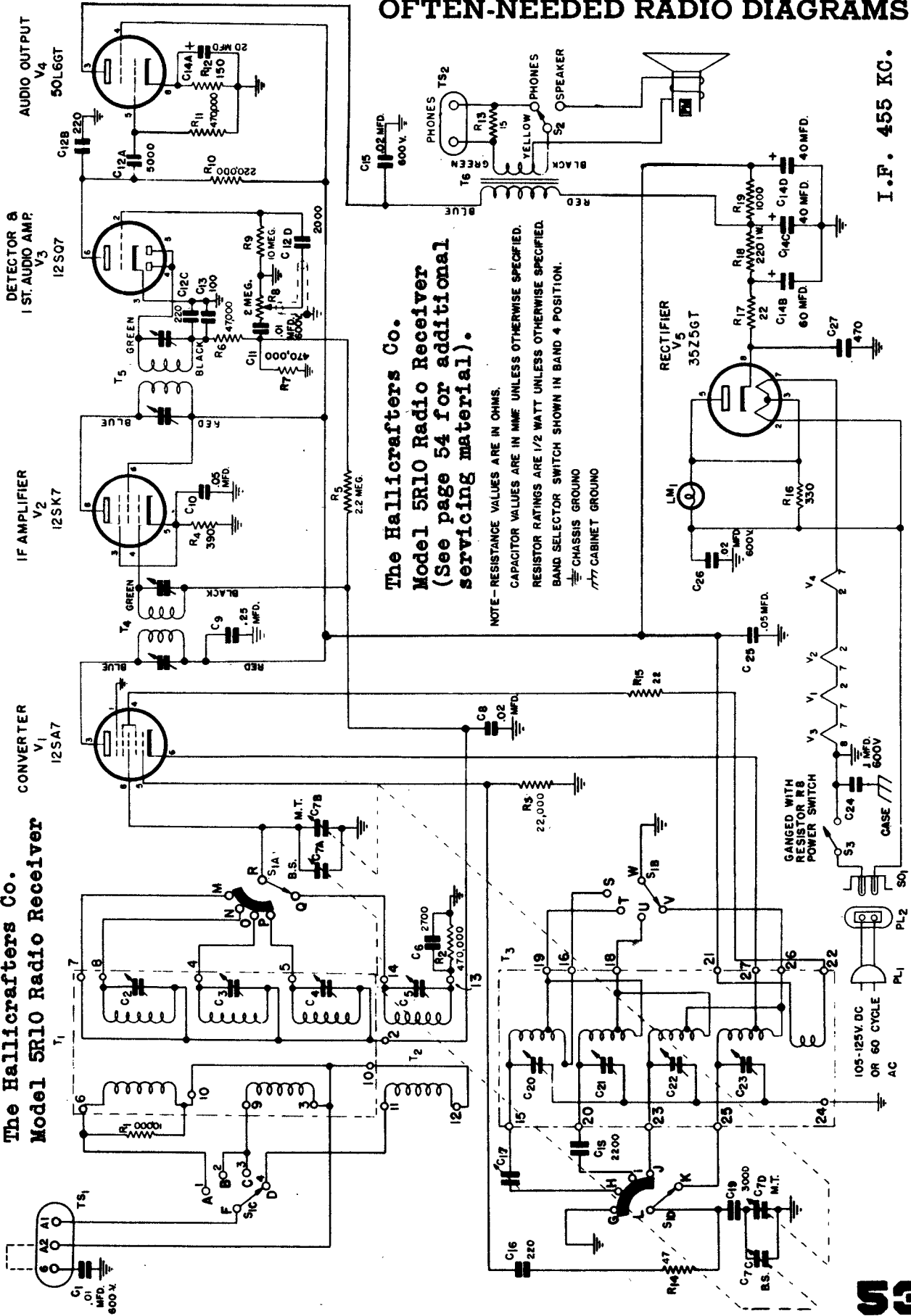

The Hallicrafters Co.
Model 5R10 Radio Receiver
(See page 54 for additional
servicing material).

NOTE - RESISTANCE VALUES ARE IN OHMS.
CAPACITOR VALUES ARE IN MME UNLESS OTHERWISE SPECIFIED.
RESISTOR RATINGS ARE 1/2 WATT UNLESS OTHERWISE SPECIFIED.
BAND SELECTOR SWITCH SHOWN IN BAND 4 POSITION.
⊥ CHASSIS GROUND
⌞ CABINET GROUND

I.F. 455 KC.

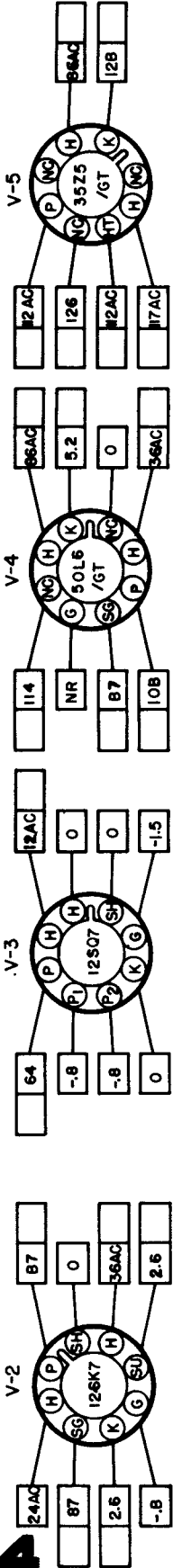

the hallicrafters co.

1. SOCKET VIEWS ARE BOTTOM VIEWS.
2. ALL VOLTAGES ARE MEASURED BETWEEN TUBE SOCKET TERMINALS & CHASSIS, WITH ZERO SIGNAL INPUT.
3. LINE VOLTAGE—117 V. AC. AC VOLTAGES WILL BE DC VOLTAGES WHEN OPERATING FROM A DC SOURCE.
4. ALL VOLTAGES SHOWN ARE DC UNLESS OTHERWISE SPECIFIED.
5. DC VOLTAGES SHOWN WERE MEASURED WITH A VACUUM TUBE VOLTMETER.
6. "NC" NO CONNECTION. (VOLTAGES SHOWN FOR THIS TERMINAL ONLY WHEN TERMINALS ARE USED AS A TIE LUG.)
7. "NR" NOT READABLE. (READING GENERALLY MEANINGLESS)
8. SPACE PROVIDED FOR SERVICE METER READINGS.
9. BAND SELECTOR SWITCH AT BAND "4" POSITION.

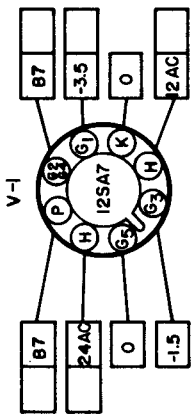

FRONT APRON
BOTTOM VIEW OF CHASSIS

I.F. 455 KC.

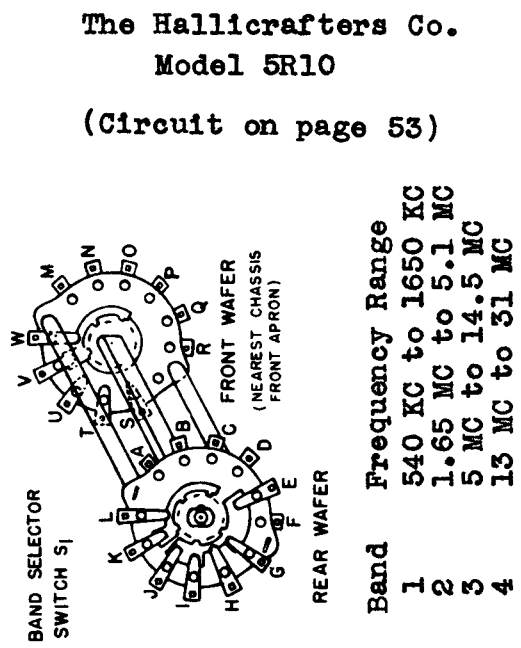
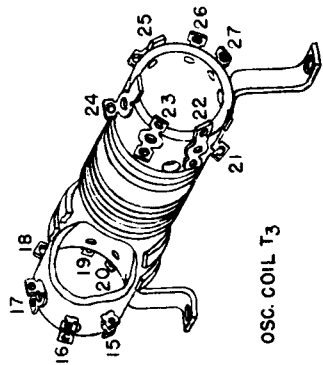
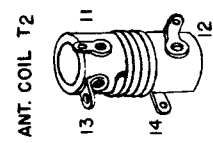
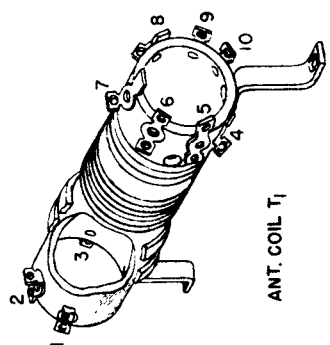

The Hallicrafters Co.
Model 5R10
(Circuit on page 53)

Band	Frequency Range
1	540 KC to 1650 KC
2	1.65 MC to 5.1 MC
3	5 MC to 14.5 MC
4	13 MC to 31 MC

NOTE: DIMENSIONS & PROPORTIONS SHOWN IN PICTORIAL VIEWS HAVE BEEN EXAGGERATED FOR CLARITY OF TERMINAL LUG LOCATION.

MANUAL OF 1951 MOST-OFTEN-NEEDED RADIO DIAGRAMS

Hoffman

SERVICE DATA

RADIO CHASSIS 165

MODELS 204, 205

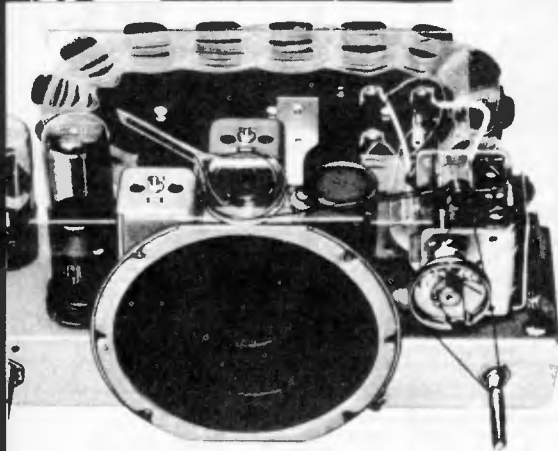

PARTS LIST

All values of capacity are microfarads unless otherwise noted.
All resistors are 1/2 watt composition type with values given in ohms unless otherwise specified.

Symbol	Part No.	Value	Tolerance	Watts or Volts
C1 } C2 } C3 } C4 }	4401	{ 0 - 388 mmf { 0 - 180 mmf		
C5	Not used			
C6	4000	100 mmf	20%	
C7	4102	.005		600
C8	4100	.05		200
C9	4001	270 mmf	20%	
C10	4102	.005		600
C11	4100	.05		200
C12	4001	270 mmf	20%	
C13	4102	.005		600
C14	4106	.02		400
C15	4100	.05		200
C16	4101	.05		400
C17		50		150
C18	4201	30		150
C19	4121	.1	20%	400
R1	4501	22K	20%	
R2	Not used			
R3	Not used			
R4	4502	2.2 meg	20%	
R5	4504	47K	20%	
R6	4505	10 meg	20%	
R7	4836	500K		
R8	4511	100K	20%	
R9	4500	220K	20%	
R10	4506	470K	20%	
R11	4510	150	20%	
R12	4508	47	20%	
R13	4700	500	10%	
R14	4506	470K	20%	5 W

NOTES:

- The pin voltage readings are obtained with no signal input to receiver.
- D.C. voltages measured with 20,000 ohm/volt meter.
- A.C. voltages measured with 1,000 ohm/volt meter.
- All voltages measured with reference to B-.
- Live voltage 115V A.C.

Pin Voltage Diagram

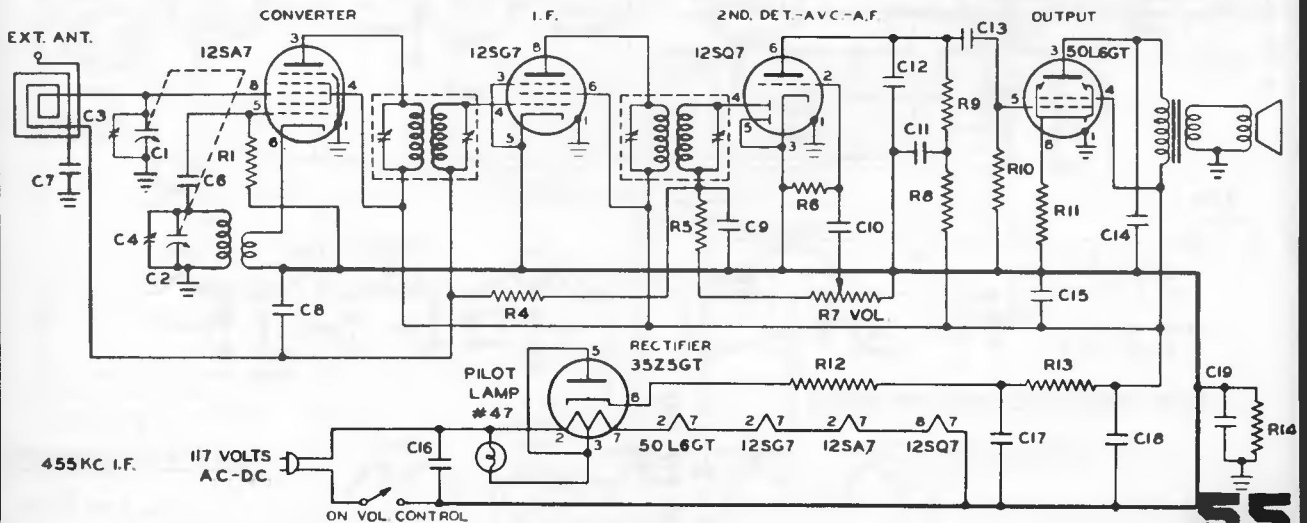
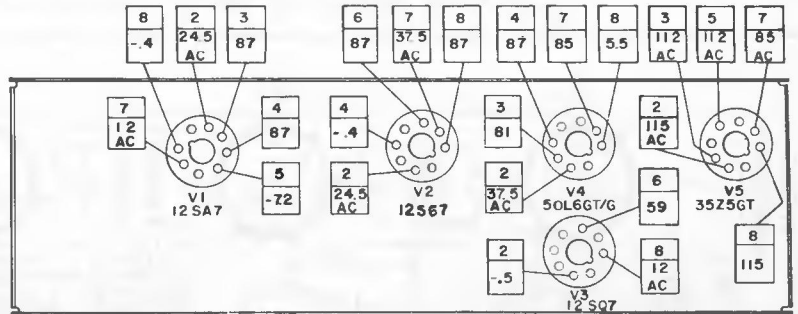

MANUAL OF 1951 MOST-OFTEN-NEEDED RADIO DIAGRAMS

Jewel Radio Corp. Model 5010U

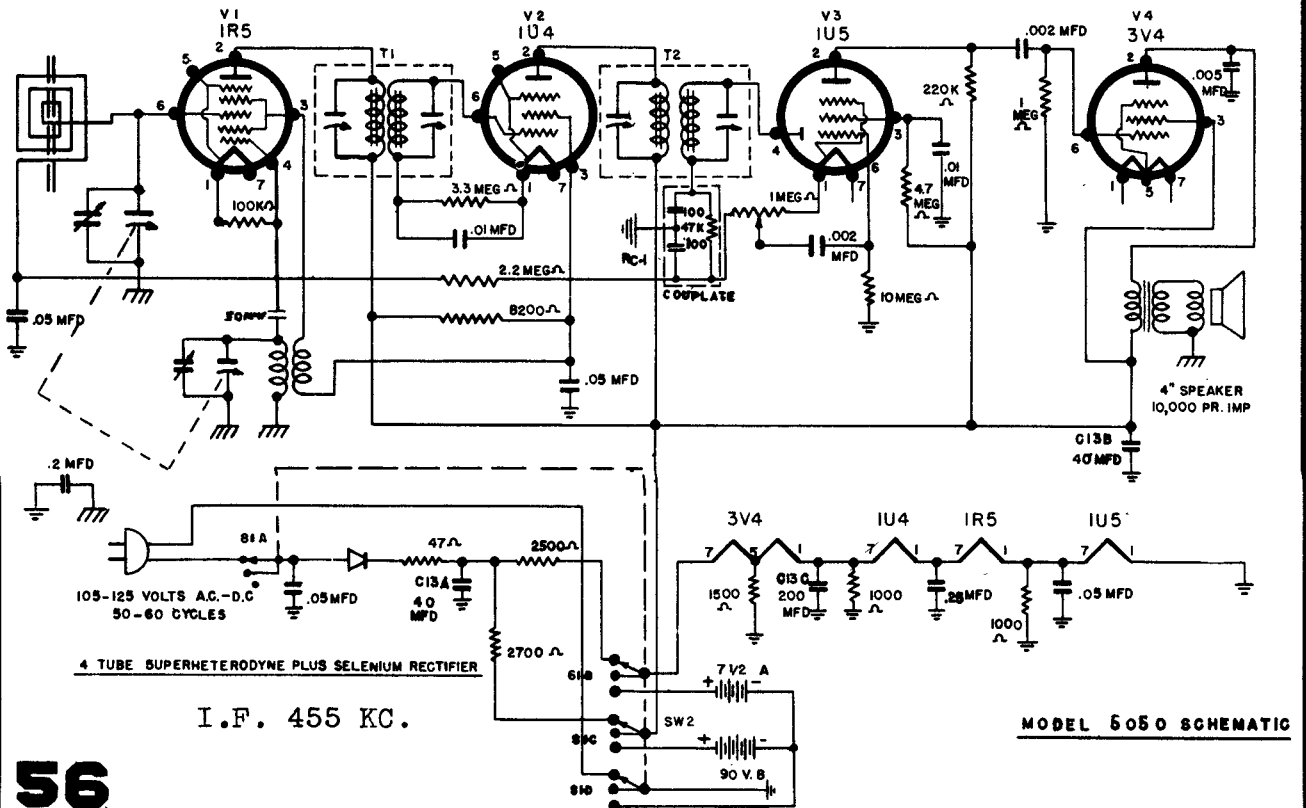
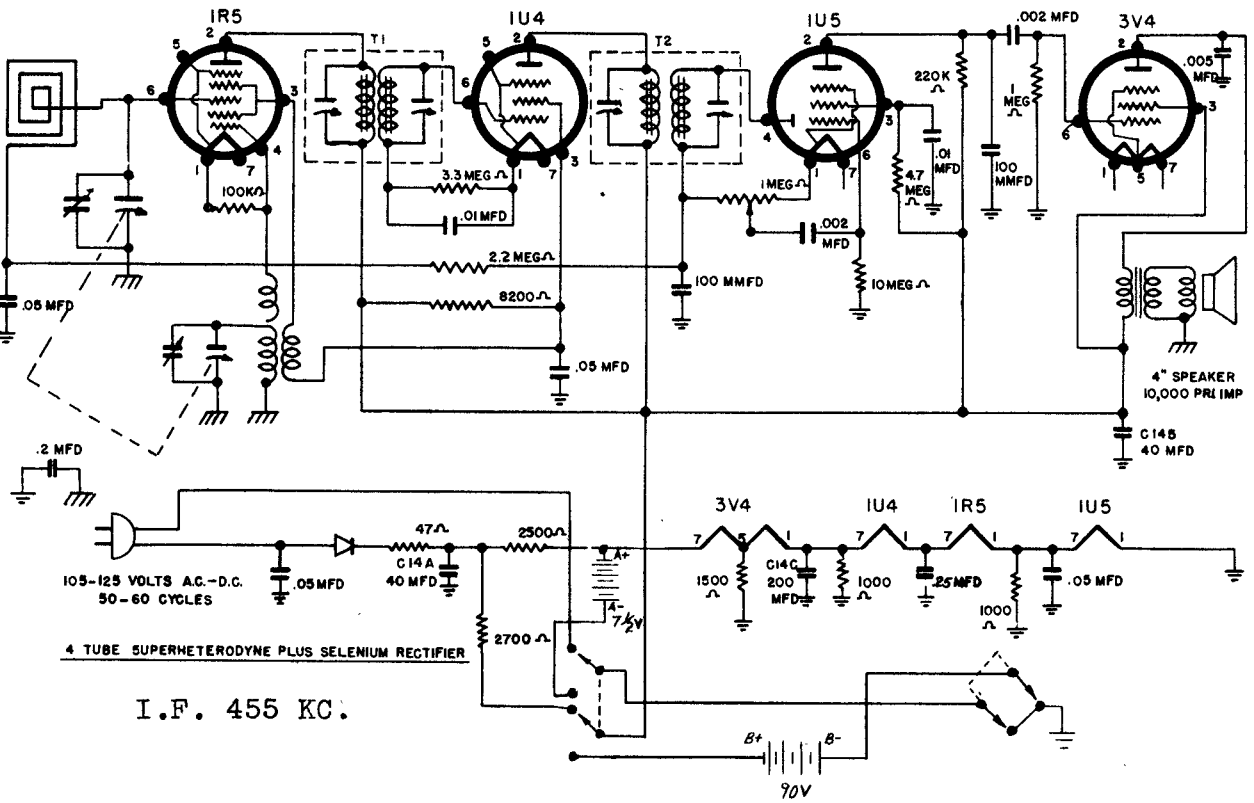

MANUAL OF 1951 MOST-OFTEN-NEEDED RADIO DIAGRAMS

Jewel Radio Corp.

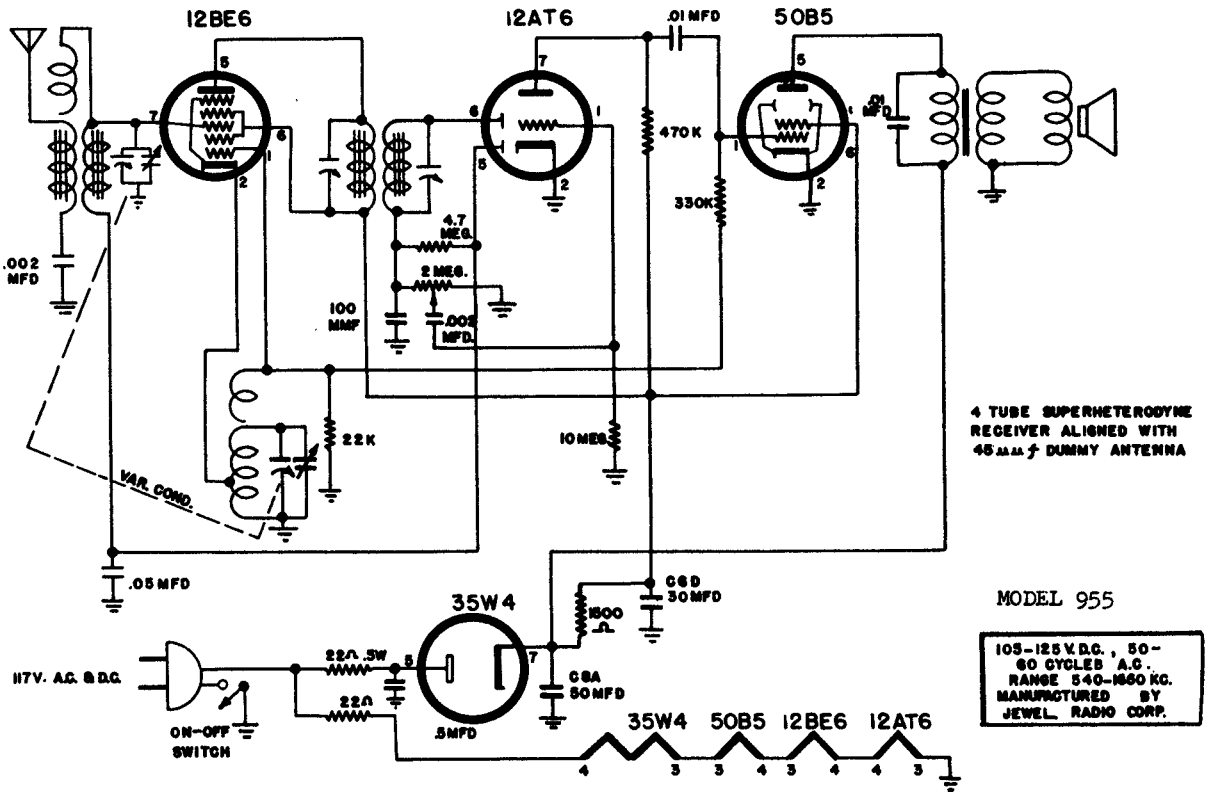

I.F. 455 KC.

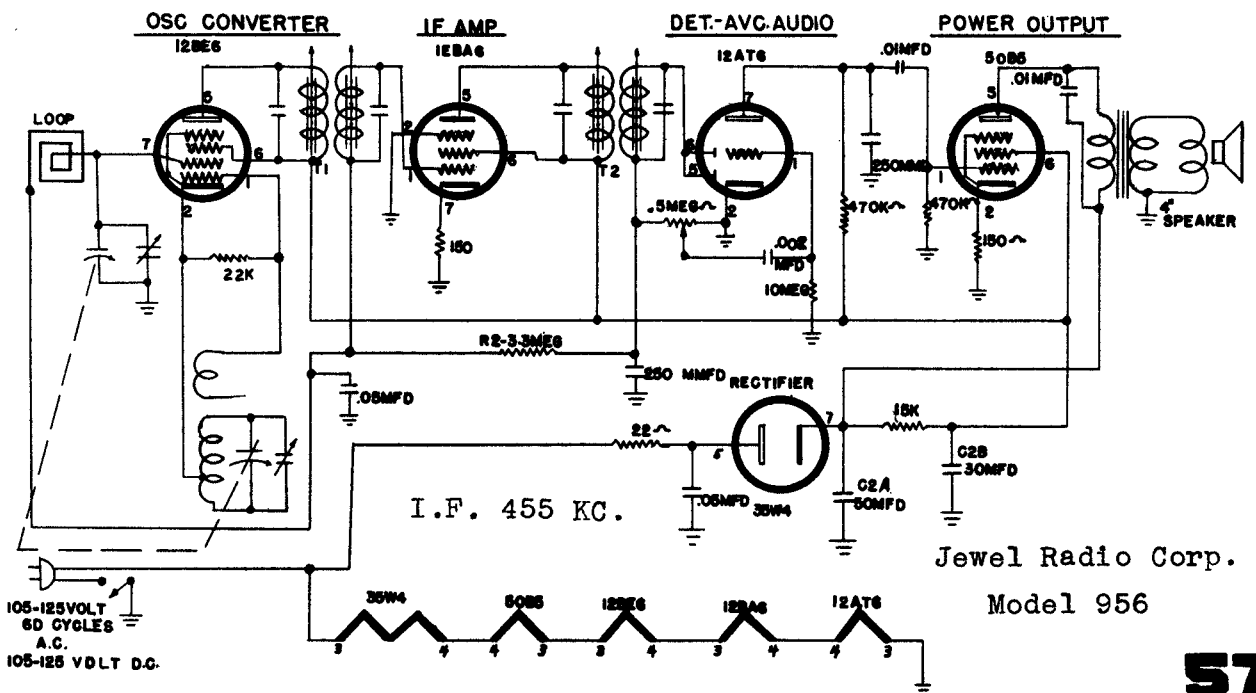

MANUAL OF 1951 MOST-OFTEN-NEEDED RADIO DIAGRAMS

Jewel Radio Corp.

Model 5057U

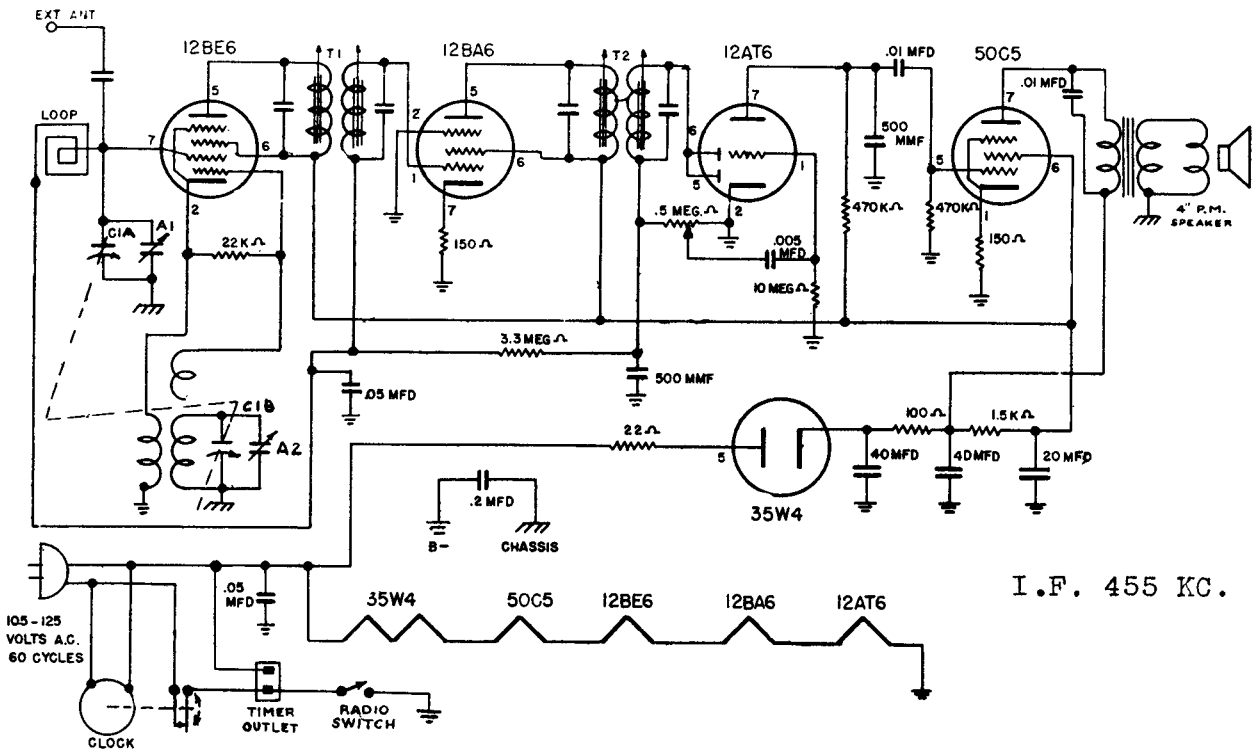

Jewel Radio Corp.

Models 960, 960U, 961

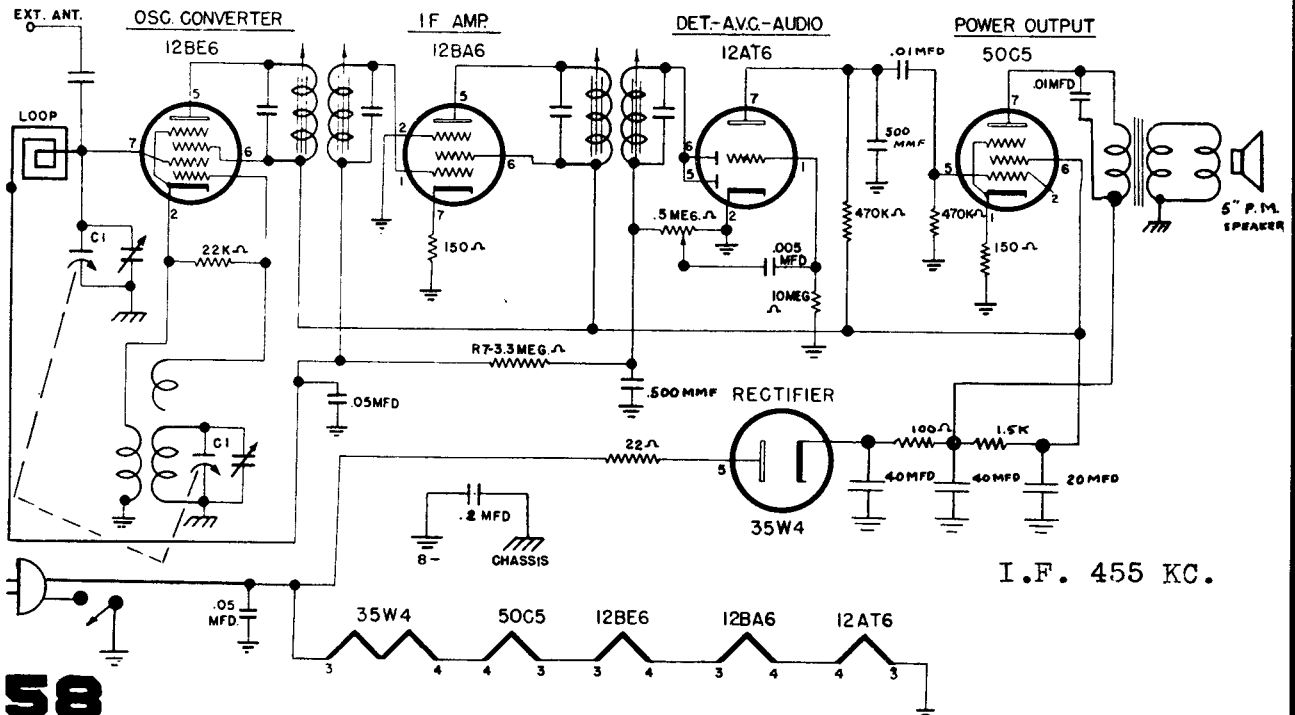

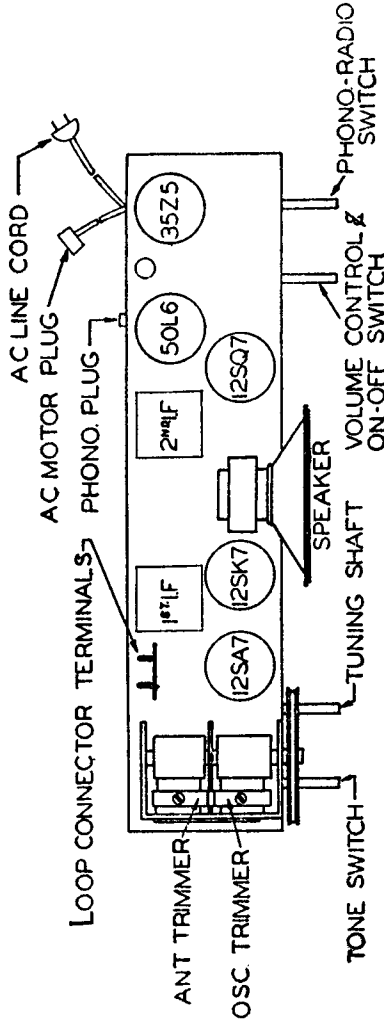

ALIGNMENT AND SERVICE DATA

Remove chassis from cabinet for alignment.

A Signal Generator is required having the following frequencies: 455 KC, 1400 KC, 1720 KC. An output meter should be connected across the speaker.

The receiver volume control should be turned to maximum during the I.F. and all subsequent alignments to keep the AVC from working and giving false readings. Keep the generator output as low as possible to prevent overloading.

FIRST STEP: Connect the hot lead from the generator to the ANT. section of the gang condenser, through a .1 MFD condenser. The ground lead from the generator must be connected to the floating ground buss under the chassis. Turn the gang condenser to complete minimum capacity. Adjust the generator to 455KC and adjust the trimmers of the 1st and 2nd I.F. transformers until a maximum reading is noted on the output meter.

SECOND STEP: With the leads from the generator still connected in the same manner, adjust the Signal Generator to 1720 KC. The OSC. trimmer is located on the front of the chassis. Adjust this trimmer until the 1720 KC signal is tuned in.

THIRD STEP: Remove the hot lead of the generator from the ANT section of the gang condenser. Connect this lead to the primary of the loop antenna through a 200 MMFD condenser. Adjust the Signal Generator to 1400 KC. Rotate the tuning control until this signal is tuned in. The ANT trimmer is located on top of the ANT. section of the gang condenser.

Adjust this trimmer until a maximum reading is noted on the output meter.

MANUAL OF 1951 MOST-OFTEN-NEEDED RADIO DIAGRAMS

KNIGHT MODEL 5G563 ALLIED RADIO CORPORATION

PART NO.	DESCRIPTION
PC-2	.05MFD. CONDENSER 200V
PC-8	.1MFD. CONDENSER 400V
MC-4	.0005MFD. MICA
MC-5	.0005MFD. MICA
PC-5	.25MFD. CONDENSER 200V
PC-6	.005MFD. MICA
PC-3	.05MFD. CONDENSER 400V
MC-2	.0001MFD. MICA
PC-7	.01MFD. CONDENSER 400V
C-9	20MFD. -150V ELECTROLYTIC
EC-14	40MFD. -150V ELECTROLYTIC
C-11	40MFD.
R-1	220M \sim RESISTOR 1/2 W. 20%
R-2	22 M \sim RESISTOR 1/2 W. 20%
R-3	47 M \sim RESISTOR 1/2 W. 20%
R-4	3.3MEG \sim RESISTOR 1/2 W. 20%
R-5	1MEG \sim RESISTOR 1/2 W. 20%
R-6	22MEG \sim RESISTOR 1/2 W. 20%
R-7	1MEG. VOLUME CONTROL
R-8	470 \sim RESISTOR 1/2 W. 20%
R-9	1000 \sim RESISTOR 1 W. 10%
R-10	33 \sim RESISTOR 1/2 W. 20%
R-11	470M \sim RESISTOR 1/2 W. 20%
R-12	2200 \sim RESISTOR 1/2 W. 30%
G-1	GANG CONDENSER
G-2	ANT. TRIMMER
G-3	OSC. TRIMMER
G-4	OSC. TRIMMER
L-1	INPUT LF. TRANSFORMER
L-2	OUTPUT LF. TRANSFORMER
L-3	OUTPUT TRANSFORMER
L-1	LOOP ANT.
L-2	OSC. COIL
SP	5" PM. SPEAKER
S-1	TO NE SWITCH
S-2	SWITCH ON VOLUME CONTROL
S-3	PHONO-RADIO SWITCH
S-4	SWITCH ON RECORD CHANGER
AC-M-7	RECORD CHANGER MOTOR
AC-PU-7	CRYSTAL PICKUP ARM CARTRIDGE
PB-2	110 V. 7 1/2 W. PILOT BULB
PL	LINE COORD

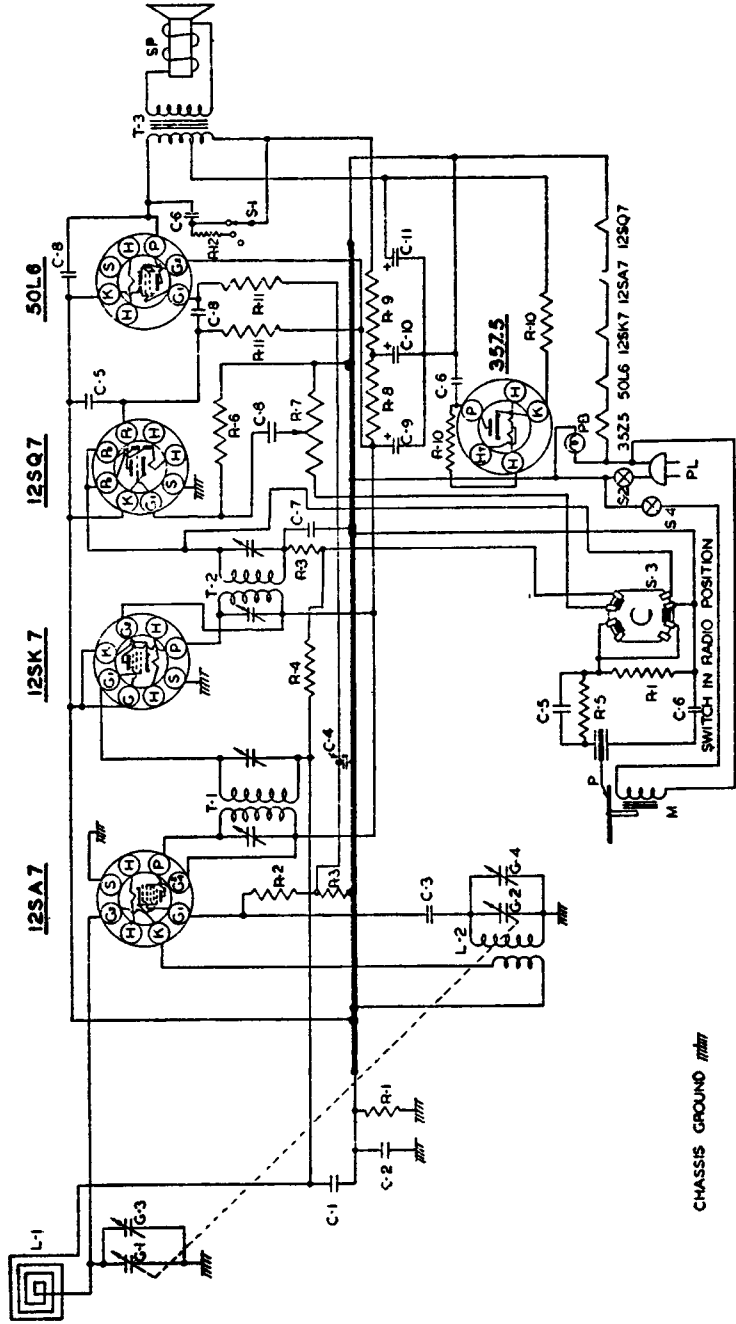

CHASSIS GROUND $\text{---} \text{---} \text{---}$

TUBE AND TRIMMER LOCATION

MANUAL OF 1951 MOST-OFTEN-NEEDED RADIO DIAGRAMS

Montgomery Ward Models 05WG-2751A, 05WG-2752B, etc. Continued on page 61

ALIGNMENT PROCEDURES

AM STAGES

The following is required for aligning:

An All Wave Signal Generator Which Will Provide an Accurately Calibrated Signal at the Test Frequencies as Listed.

Output Indicating Meter, Non-Metallic Screwdriver, Dummy Antennas
— .1 mf, and 50 mmf.

Volume Control Maximum all Adjustments.

Connect Radio Chassis to Ground Post of Signal Generator with a Short Heavy Lead.

Allow Chassis and Signal Generator to "Heat Up" for Several Minutes.

SIGNAL GENERATOR				GANG CONDENSER SETTING	ADJUST	ADJUST FOR
FREQUENCY SETTING	CONNECT GENERATOR OUTPUT TO	THROUGH DUMMY ANTENNA	CONNECT GROUND TO			
455 KC	Control Grid 1st 6BA6 Pin No. 1	.1 mf	Chassis Base	Rotor Fully Open	2nd I.F. Pri. (1) and Sec. (2)	Maximum Output
455 KC	Control Grid 6BE6 Pin No. 7 1st Det.	.1 mf	Chassis Base	Rotor Fully Open	1st I.F. Pri. (3) and Sec. (4)	Maximum Output
455 KC	Control Grid 6BE6 Pin No. 7	.1 mf	Chassis Base	Rotor Fully Open	2nd I-F Pri. (1) and Sec. (2)	Maximum Output
1620 KC	Control Grid 6BE6 Pin No. 7	.1 mf	Chassis Base	Rotor Fully Open	Oscillator C-41	Maximum Output
1400 KC	External Antenna Terminal	50 mmf	Chassis Base	Turn Rotor to Max. Output. Set Pointer to 1400 KC See Note A	Antenna C-2	Maximum Output

NOTE A—If the pointer is not at 1400 KC on the dial, reset pointer to the 1400 KC mark on the dial scale.

FM STAGES

The following is required for aligning:

An accurately calibrated signal generator providing unmodulated signals at the test frequencies listed below.

Non-metallic screwdriver.

Dummy Antennas and I-F Loading Resistor—2500 mmf, 300 ohms

Zero center scale DC vacuum tube voltmeter having a range of approximately 3 volts.

(If a zero center scale meter is not available, a standard scale vacuum tube voltmeter may be used by reversing the meter connections for negative readings.)

Allow chassis and signal generator to "Heat Up" for several minutes.

SIGNAL GENERATOR			THROUGH DUMMY ANTENNA	BAND SWITCH SETTING	GANG CONDENSER SETTING	ADJUST	ADJUST FOR
	FREQUENCY SETTING	CONNECT GENERATOR OUTPUT TO					
Discriminator	10.7 MC	6BA6 2nd I-F Pin 1 and Chassis	2500 mmf	FM	Rotor Fully Open	Disc. Pri. (5) Note A	Maximum Deflection
	10.7 MC	6BA6 2nd I-F Pin 1 and Chassis	2500 mmf	FM	Rotor Fully Open	Disc. Sec. (6) Note B	
I-F	10.7 MC Note C	6BA6 1st I-F Pin 1 and Chassis	2500 mmf	FM	Rotor Fully Open	2nd I-F Pri. (7) Sec. (8) Note D	Maximum Deflection
Discriminator	10.7 MC	6BA6 1st I-F Pin 1 and Chassis	2500 mmf	FM	Rotor Fully Open	Disc. Pri. (5) Note D	Maximum Deflection
I-F	10.7 MC	Junction C-32A & B (Dual 100 mmf cond.) And chassis	2500 mmf	FM	Rotor Fully Open	1st I-F Pri. (9) & Sec. (10) 2nd I-F Pri. (7) & Sec. (8) Disc. Pri. (5) In Order Shown Note D	Maximum Deflection
	10.7 MC	Same as above	2500 mmf	FM	Rotor Fully Open	Disc. Sec. (6) Note B	

RECHECK I-F ADJUSTMENTS IN ORDER GIVEN

Oscillator	108.5	Disconnect built-in dipole antenna and connect generator to dipole terminals with resistor in series.	300 ohms	FM	Rotor Fully Open	Osc. C-25	Deflection Maximum
Antenna	104.5	Same as above	300 ohms	FM	Tune rotor for max. AVC voltage	Ant. C-39	Maximum Deflection

RECHECK ANTENNA & OSC. ADJUSTMENTS IN ORDER GIVEN

FM ALIGNMENT NOTES

NOTE A—The zero center scale DC vacuum tube voltmeter is to be connected between chassis ground and the AVC line. A signal of .1 volt must be fed into the receiver for this adjustment.

Note output voltage on the zero center DC vacuum tube voltmeter.

NOTE B—Disconnect zero center DC vacuum tube voltmeter from AVC and connect it at the audio takeoff point at the

27 K ohm resistor (R-10) and its junction with the terminal strip. Adjust for zero voltage indication.

NOTE C—AM I-F coils must be aligned before attempting to align the FM I-F coils.

NOTE D—Connect zero center DC vacuum tube voltmeter as in Note A. Adjust input to give same output on the zero center DC vacuum tube voltmeter as in Note A.

MANUAL OF 1951 MOST-OFTEN-NEEDED RADIO DIAGRAMS

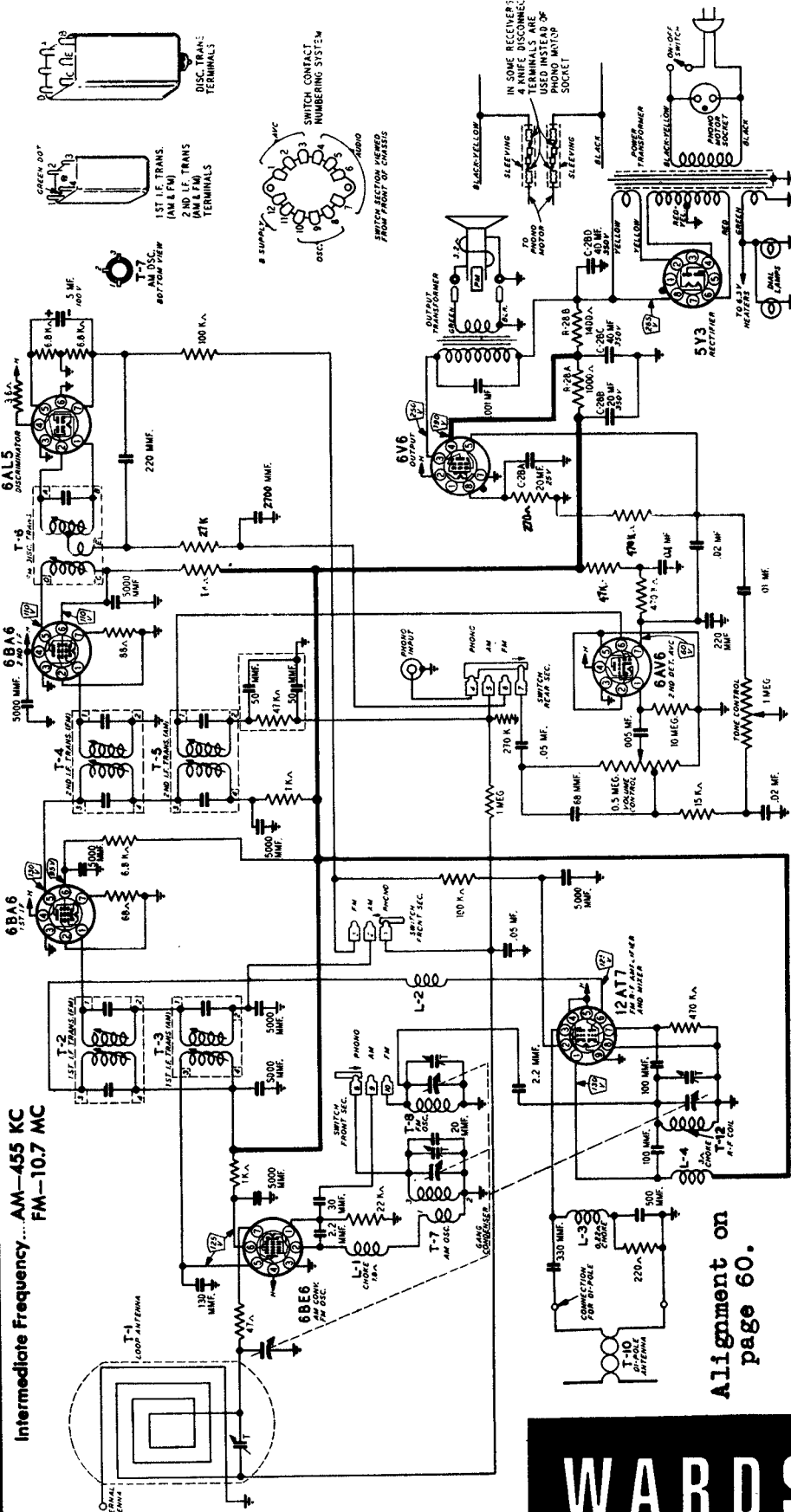

M O N T G O M E R Y W A R D MODELS 05WG-2751A & 05WG-2752B

Models 05WG-2752, 05WG-2752C, and 15WG-2752D differ from models listed above and presented on this page in cabinet or record changer. Model 15WG-2752E also uses an AF coupling pack.

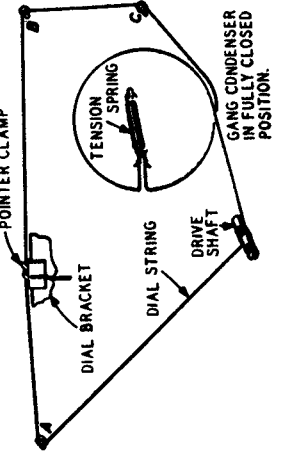

TUBE SOCKET VOLTAGES

Socket voltages are shown on the schematic diagram at the tube socket terminals. All voltages are between the socket terminal and chassis ground. Plate, screen and cathode voltages were taken with a 1000 ohm-per-volt meter with a 300 volt scale used for plate and screen voltages. Audio grid voltages were read with a vacuum tube volt-meter.

Conditions of measurement are:

Line voltage 117 Volts AC

Signal Input None

WARDS

MANUAL OF 1951 MOST-OFTEN-NEEDED RADIO DIAGRAMS

Montgomery Ward
MODELS 05BR-1536A, 1537A

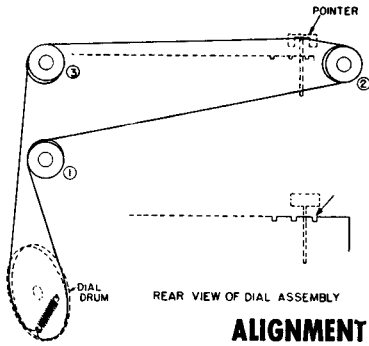

Models with suffix "B" use 35Z5 in place of 35W4

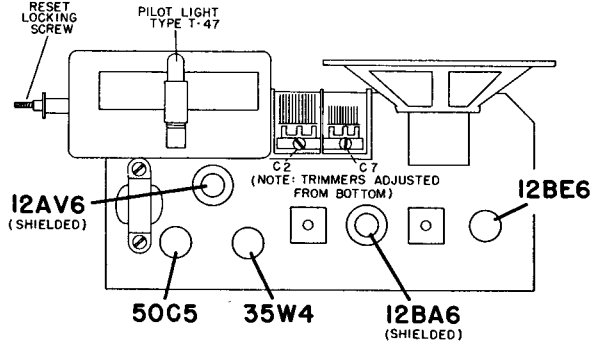

CHASSIS VIEW, SHOWING TUBE LOCATIONS

ALIGNMENT PROCEDURE AND RECEIVER STAGE SENSITIVITIES

The signal source must be an accurately calibrated signal generator capable of supplying R. F. signals modulated 30% with a 400-cycle audio signal. A 400-cycle source is necessary for the audio measurement.

The table below lists the sensitivity at various points. All measurements are based on an output of 50-milliwatts. This may be measured by disconnecting the

speaker voice coil and substituting a 3.2-ohm, 5-watt resistor across the secondary winding of the output transformer. A reading of .4 volts AC across this resistor will be equivalent to a 50-milliwatt output with the speaker connected. Variations of plus or minus 25% are usually permissible. Volume control at maximum for all adjustments.

SIGNAL GENERATOR				TUNER SETTING	ADJUST FOR MAXIMUM OUTPUT	INPUT FOR 50-MILLIWATT OUTPUT
Frequency	Coupling Capacitor	Connection to Radio	Ground Connection			
455 kc.	.1 mf.	Pin No. 7 of 12BE6	Buss wire	Rotor full open	Trimmers on output and input I.F. cans	50 microvolts
1700 kc.	.1 mf.	Pin No. 7 of 12BE6	Buss wire	Rotor full open	Oscillator trimmer C7 (on top)	_____
1400 kc.	none	See note A	none	Set dial at 1400	Antenna trimmer C2 (on top)	_____
1400 kc.	.1 mf.	External antenna clip	Buss wire	1400 kc.	_____	50 microvolts
400 cycles	.1 mf.	12AV6, Pin 1	Buss wire	_____	_____	.03 volts

Note A: Lay output lead of generator in back of loop antenna. Turn up generator output. Loop antenna will pick up energy.

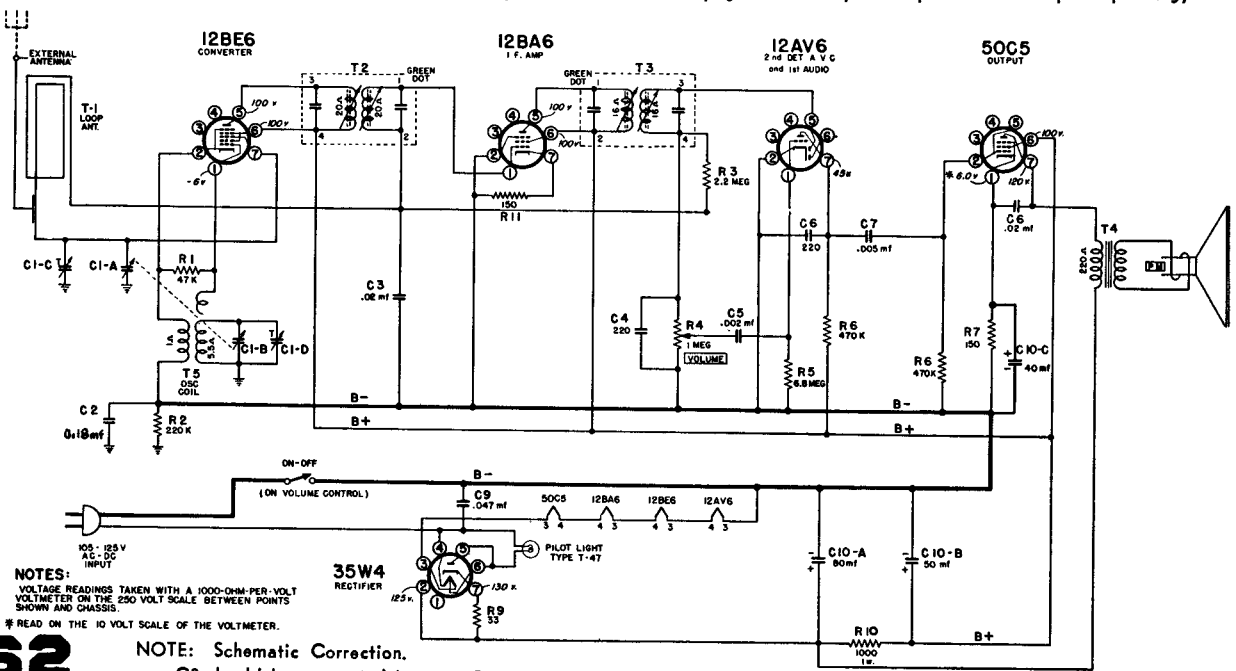

NOTES:
 VOLTAGE READINGS TAKEN WITH A 1000-OHM-PER-VOLT VOLTMETER ON THE 250 VOLT SCALE BETWEEN POINTS SHOWN AND CHASSIS.
 * READ ON THE 10 VOLT SCALE OF THE VOLTMETER.

NOTE: Schematic Correction.
 C8 should be connected between Pin 7 of the 50C5 tube to B-

MANUAL OF 1951 MOST-OFTEN-NEEDED RADIO DIAGRAMS

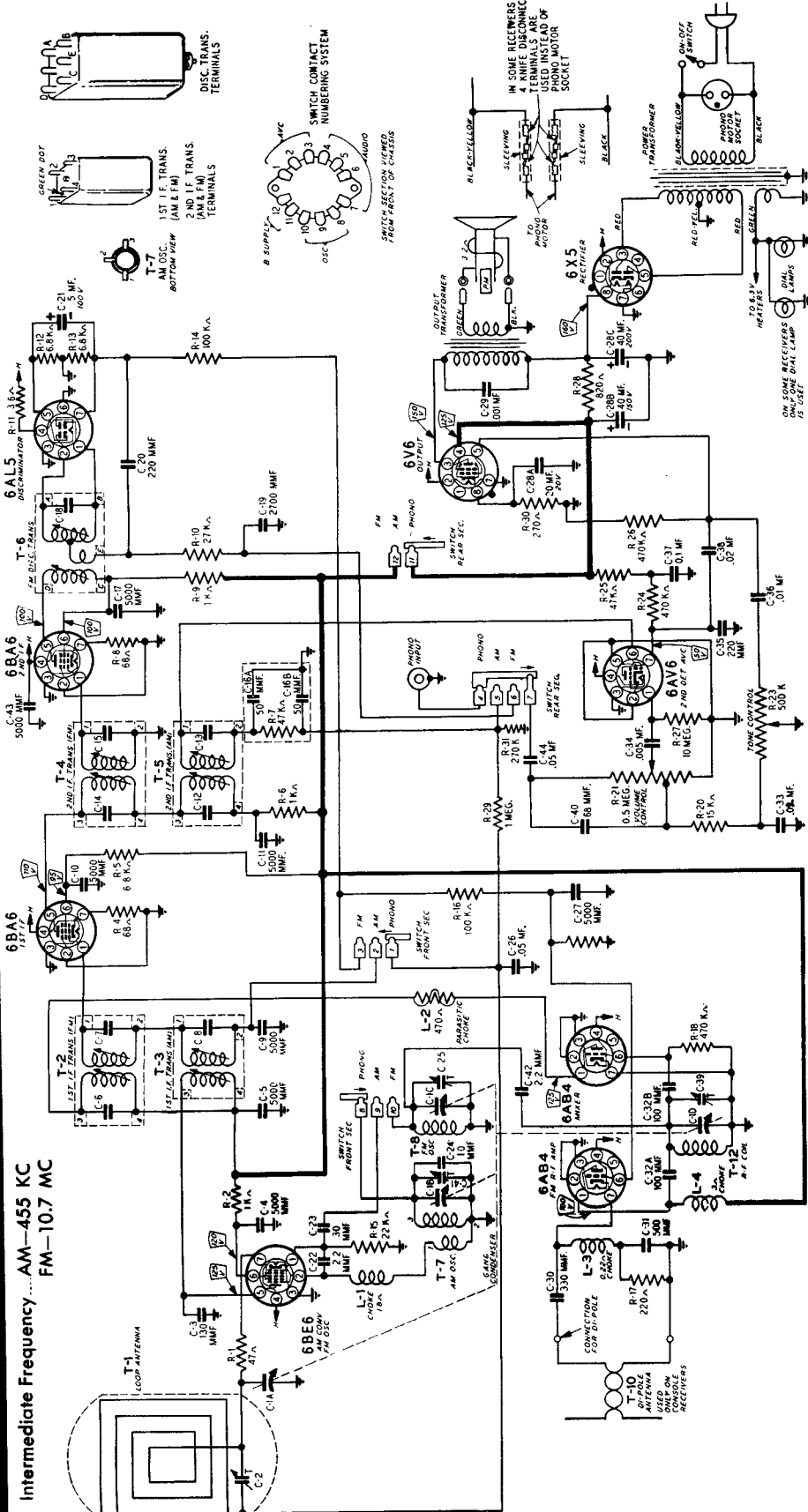

Intermediate Frequency...AM-455 KC
FM-10.7 MC

TUBE SOCKET VOLTAGES

Socket voltages are shown on the schematic diagram at the tube socket terminals. All voltages are between the socket terminal and chassis ground. Plate, screen and cathode voltages were taken with a 1000 ohm-per-volt meter with a 300 volt scale used for plate and screen voltages. Audio grid voltages were read with a vacuum tube volt-meter. Conditions of measurement are:

- Line voltage117 Volts AC
- Signal InputNone
- A variation of $\pm 10\%$ is usually permissible.

M O N I T O R I N G O M E R Y W A R D

AM-FM MANTEL RADIO

MODEL
05WG-1813A

Model 15WG-1813B is similar, but uses 12AT7 tube instead of two 6AB4 tubes.

MODEL
05WG-2748F

AM-FM CONSOLE

Models of the above number, but with suffix C, D, or E, or Models 94WG-2748B and 94WG-2748C are the same as model here described but use a different record changer. Model 94WG2748A has minor circuit differences from these models.

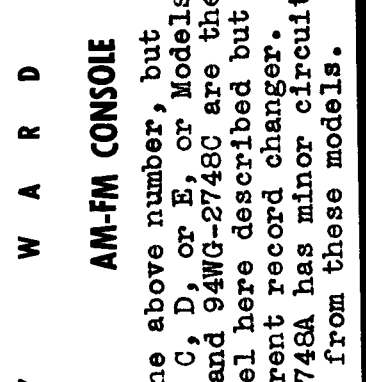
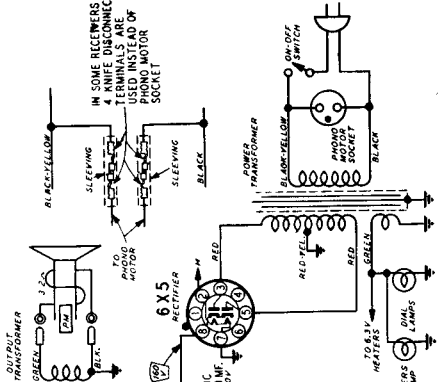
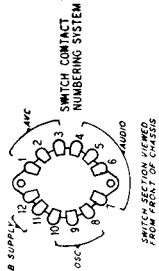
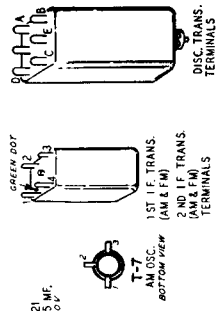

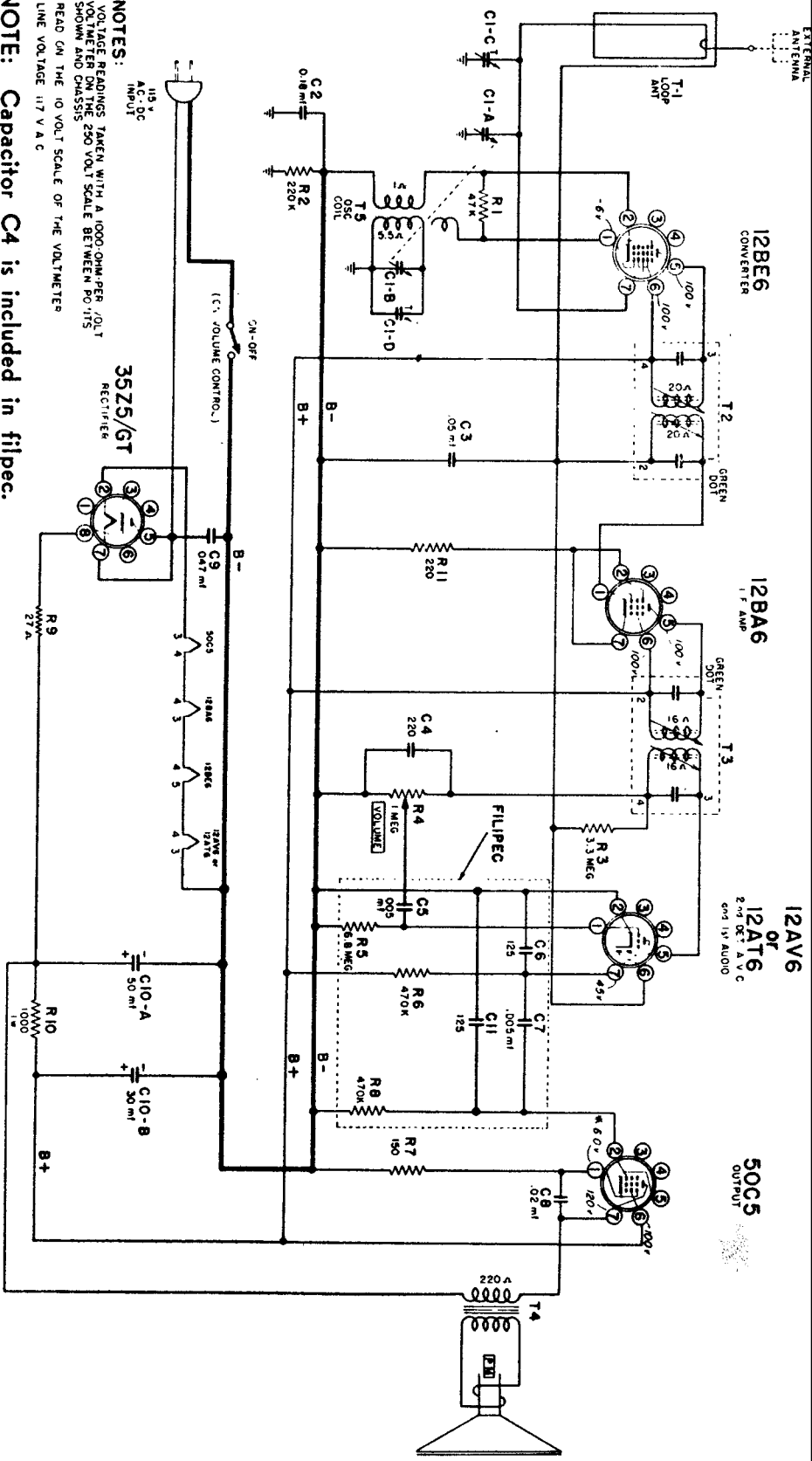

12BE6
CONVERTER

12BA6
1.7 AMP

12AV6
OR
12AT6
2.05 DC7 A V C
6MS 15V AUDIO

50C5
OUTPUT

NOTES:

VOLTAGE READINGS TAKEN WITH A 1000 OHM PER VOLT
VOLTMETER ON THE 250 VOLT SCALE BETWEEN PO 115
SHOWN AND CHASSIS
* READ ON THE 10 VOLT SCALE OF THE VOLTMETER
LINE VOLTAGE 117 V A C

64 NOTE: Capacitor C4 is included in filpec.

MANUAL OF 1951 MOST-OFTEN-NEEDED RADIO DIAGRAMS

M O N I T O R I N G M E R I T W A R D

MODEL NO.

15BR-1543A

15BR-1544A

Power Supply 115 volts, DC or 50-60 cycle AC,
24 watts.

Frequency Range 540 to 1600 Kc.

Intermediate Freq. 455 Kc.

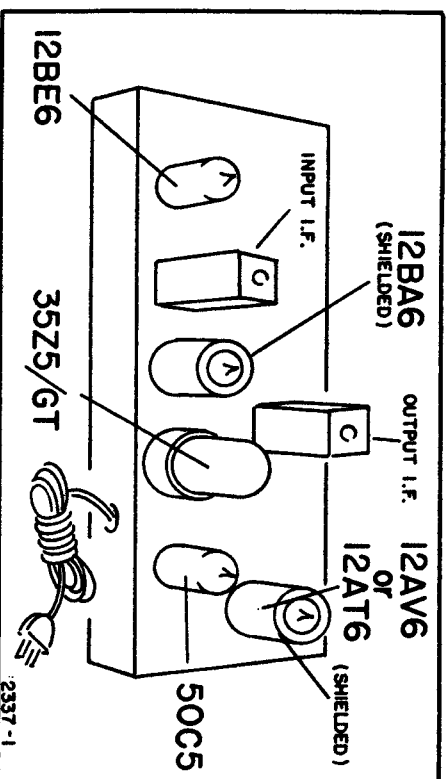

Top Chassis View

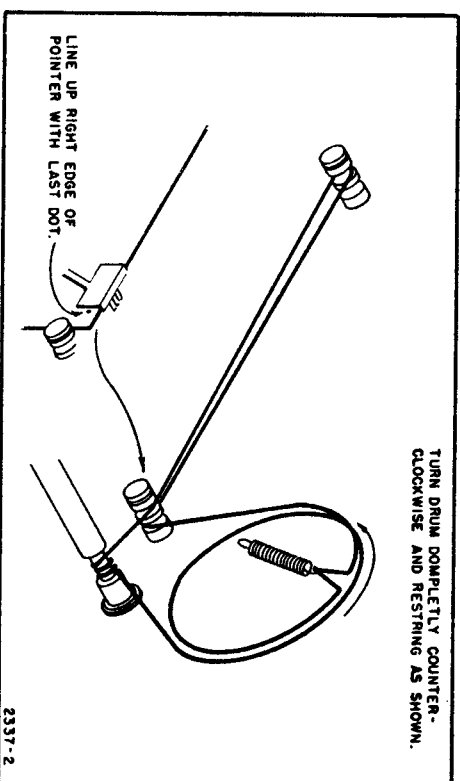

Dial Stringing Diagram

ALIGNMENT PROCEDURE

- Loop must be connected and set volume to maximum.

SIGNAL GENERATOR

Frequency	Coupling Capacitor	Connection to Radio	Ground Connection
455 kc.	.1 mf	12BE6, Pin 7	HEAVY BUSS LEAD ACROSS CENTER OF CHASSIS
1620 kc.	.1 mf	12BE6, Pin 7	
535 kc.	.1 mf.	12BE6, Pin 7	
1400 kc.	_____	Lay generator lead near back of cabinet	
400 cycles	.1 mf	12AT6, Pin 1	

TUNER SETTING

ADJUST FOR MAXIMUM OUTPUT

INPUT FOR 50-MILLIWATT OUTPUT

Capacitor fully open (plates out of mesh)	Top and bottom Cores in output and input I.F. cans	65 microvolts
Capacitor fully open (plates out of mesh)	Oscillator trimmer C1-D on gang	70 microvolts
Capacitor fully closed	Check for adequate range	70 microvolts
Tune in 1400 kc. signal	Antenna trimmer C-1C on gang	200 to 400 microvolts
_____	_____	.06 volts

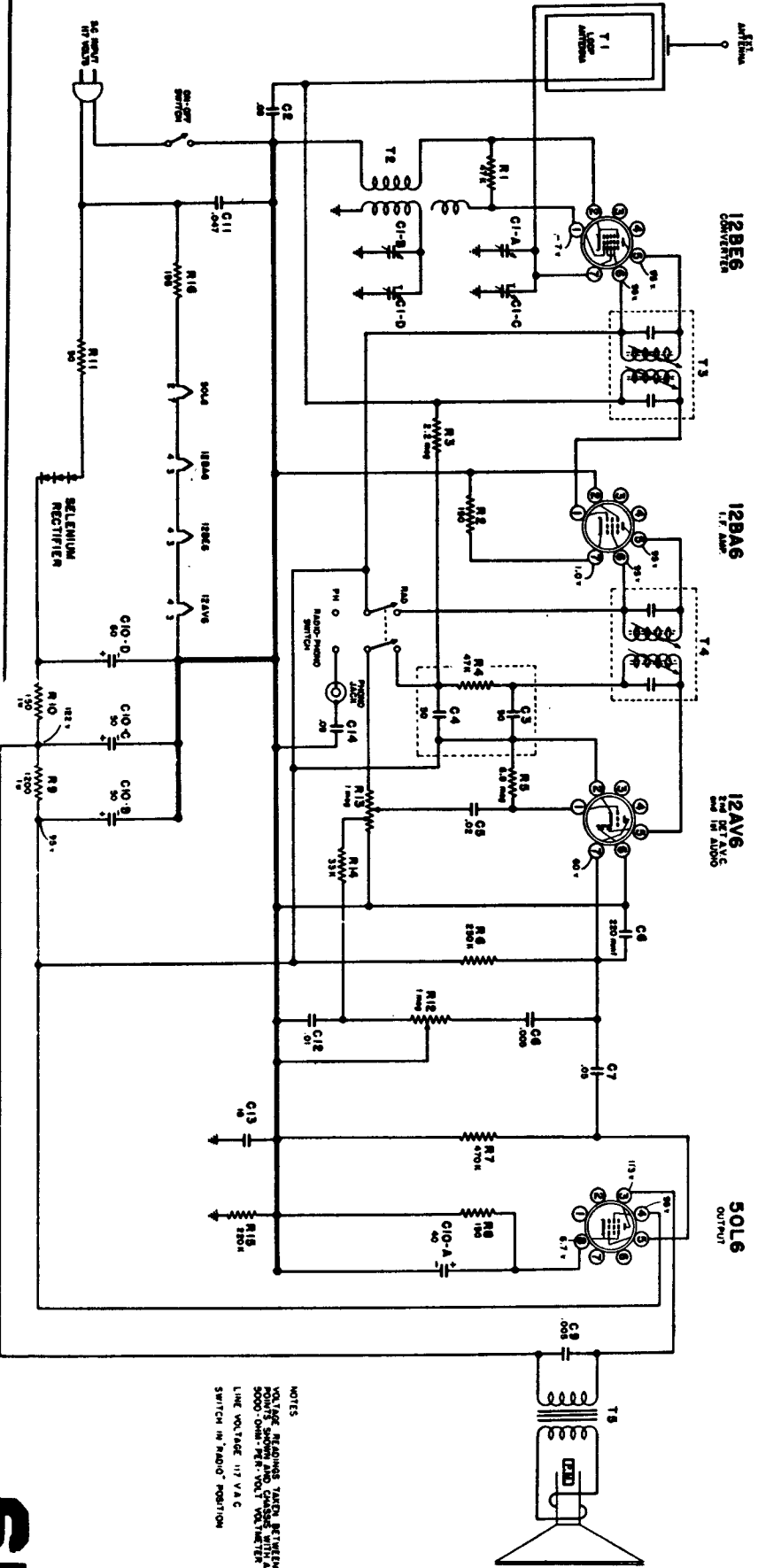

NOTE: Either a 12AT6 or a 12AV6 tube may be used.

NOTES
 VOLTAGE READINGS TAKEN BETWEEN
 POINTS SHOWN AND CHANGED WITH A
 5000 OHM PER VOLT VOLTMETER
 LINE VOLTAGE 117 V A C
 SWITCH IN "RADIO" POSITION

MANUAL OF 1951 MOST-OFTEN-NEEDED RADIO DIAGRAMS

12A7G
or
12AV6

M O N I T G O M E R Y

W A R D

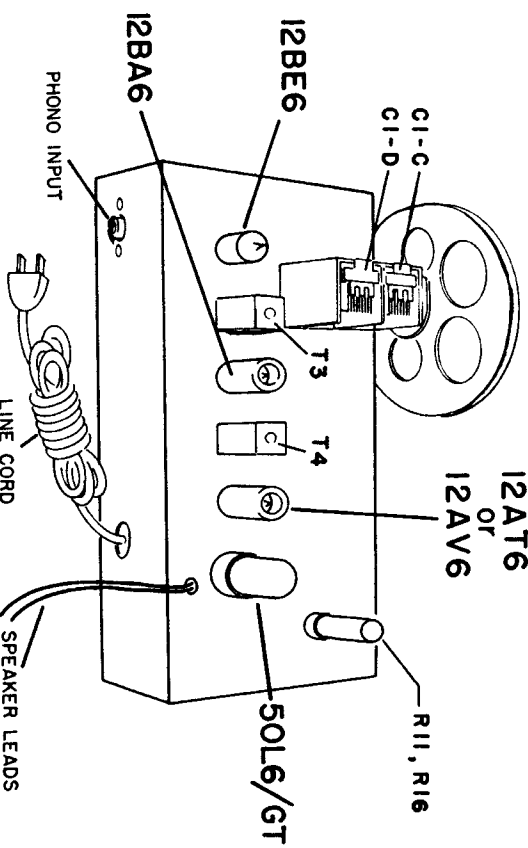

TABLE RADIO

MODEL NO.

15BR-1547A

ALIGNMENT PROCEDURE AND RECEIVER STAGE SENSITIVITIES

Alignment must be done in the cabinet.

The signal source must be an accurately calibrated signal generator capable of supplying 455 Kc and up to 1620 Kc signals modulated 30% with a 400-cycle audio signal.

To connect the output meter, disconnect the speaker and substitute a 3.2 ohm, 5 watt resistor across the secondary winding of the output transformer. Connect output meter across 3.2 ohm resistor.

- Volume control at maximum for all adjustments.
- Align for maximum output. Reduce input as needed to keep output near 0.4 volts.
- Loop antenna should be connected to receiver and in its proper position when making adjustments.

SIGNAL GENERATOR

Frequency	Coupling Capacitor	Connection to Radio	Ground Connection	TUNER SETTING	ADJUST FOR MAXIMUM OUTPUT
455 kc.	.1 mf.	12BE6, Pin 7	B MINUS POINT BUSS LEAD	Capacitor fully open (plates out of mesh)	Top and bottom Cores in output and input I.F. cans
1620 kc.	.1 mf.	12BE6, Pin 7		Capacitor fully open (plates out of mesh)	Oscillator trimmer C1-D on gang
535 kc.	.1 mf.	12BE6, Pin 7		Capacitor fully closed	Check for adequate range
1400 kc.	—	Lay Generator lead near back of cabinet.		Set dial pointer at 1400 kc.	Antenna trimmer C1-C on gang

MANUAL OF 1951 MOST-OFTEN-NEEDED RADIO DIAGRAMS

MONTGOMERY WARD

RADIO

Model Nos.

15GCB-1583

15GCB-1584

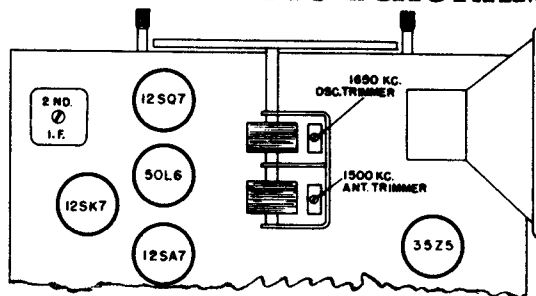

SIGNAL GENERATOR				DIAL SETTING	ADJUST FOR MAXIMUM OUTPUT
Frequency	Coupling	Connection to Radio	Ground Connection		
455 KC	.1 mfd condenser	Stator lug Var. Capacitor (front section)	Lug on Power Switch	Variable Condenser fully open	Trimmers 1st and 2nd I.F. transformer
1650 KC	Coupling loop	None	None	Variable Condenser fully open	Oscillator Trimmer (front section)
1500 KC	Coupling loop	None	None	1500 KC	Ant. Trimmer (rear section)

TUBE COMPLEMENT AND VOLTAGE CHART

TUBE TYPE	PIN 1	PIN 2	PIN 3	PIN 4	PIN 5	PIN 6	PIN 7	PIN 8
12SA7 Converter	-.8	25 A.C.	85	85	-.8	0	12 A.C.	-.8
12SK7 IF Amplifier	-.8	37 A.C.	-.8	-.8	0	85	25 A.C.	85
12SQ7 Det., AVC, Aud. Amp.	-.8	-.8	0	-.8	-.8	45	12.6 A.C.	0
50L6 Beam Power Amp.	---	84 A.C.	104	85	0	---	37 A.C.	5
35Z5 Rectifier	---	117 A.C.	112 A.C.	85	117 A.C.	110	84A.C.	116

All readings with VTVM measured to B minus

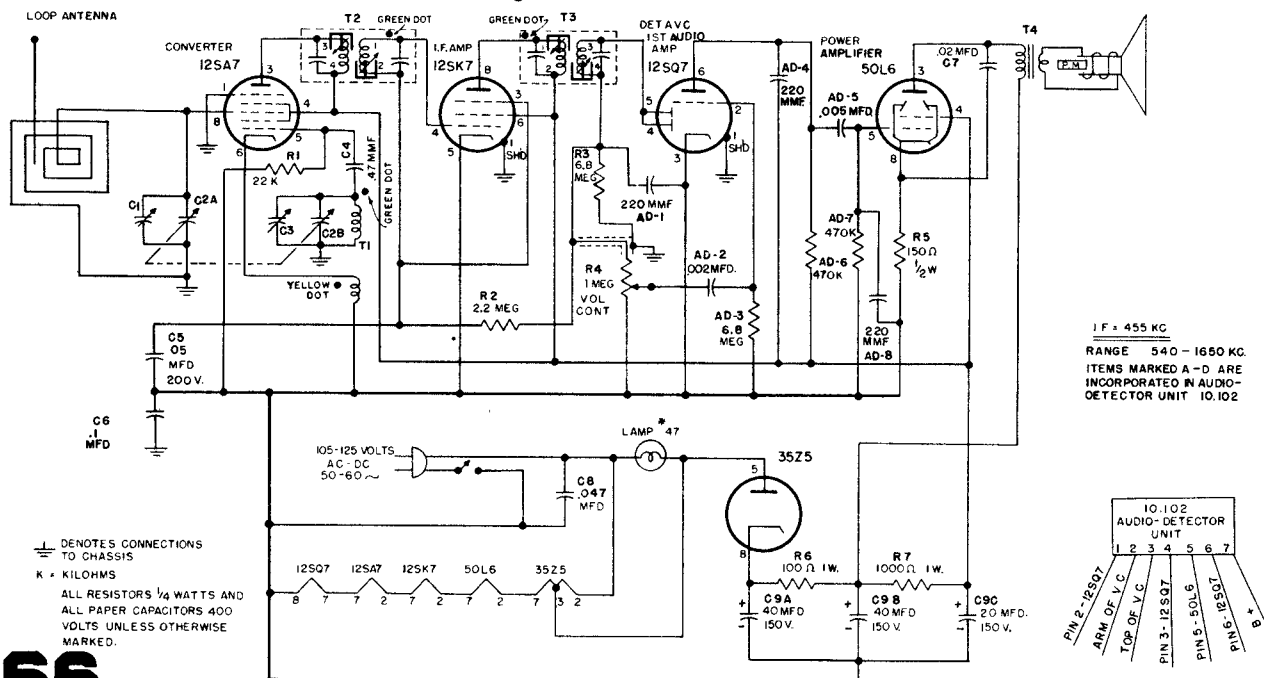

IF = 455 KC
RANGE 540 - 1650 KC.
ITEMS MARKED A-D ARE
INCORPORATED IN AUDIO-
DETECTOR UNIT 10.102

⊥ DENOTES CONNECTIONS
TO CHASSIS
K = KILOHMS
ALL RESISTORS 1/4 WATTS AND
ALL PAPER CAPACITORS 400
VOLTS UNLESS OTHERWISE
MARKED.

MANUAL OF 1951 MOST-OFTEN-NEEDED RADIO DIAGRAMS

M O N T G O M E R Y W A R D

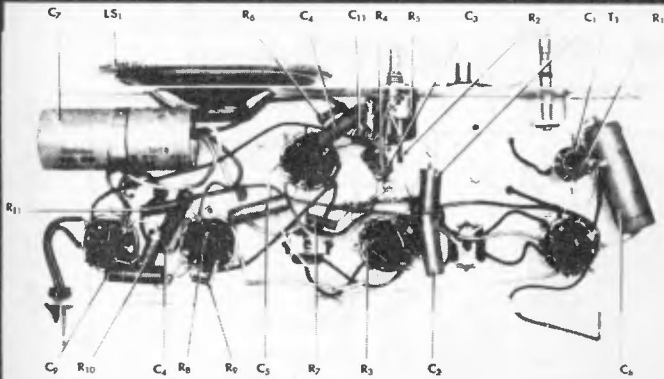

DIAL CORD STRINGING

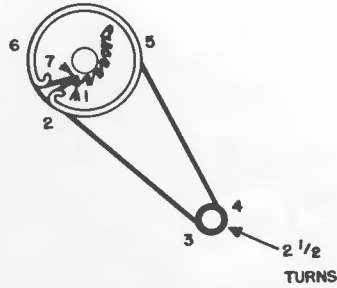

RADIO TABLE MODELS
15HA-1553A
15HA-1554A

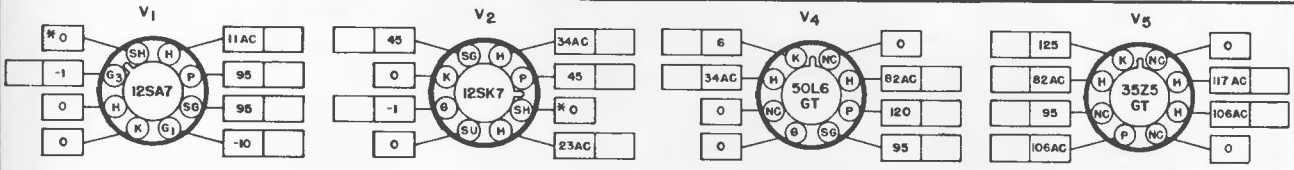

*CAUTION—SEE NOTE 9.

Intermediate Frequency.455 KC

1. SOCKET VIEWS ARE BOTTOM VIEWS.
2. ALL VOLTAGES ARE MEASURED BETWEEN TUBE SOCKET TERMINALS AND ELECTRICAL GROUND (NOT CHASSIS) WITH ZERO SIGNAL INPUT.
3. LINE VOLTAGE—117 V. AC.
4. ALL VOLTAGES SHOWN ARE DC UNLESS OTHERWISE SPECIFIED. AC VOLTAGES SHOWN BECOME DC WHEN OPERATING FROM A DC LINE.
5. DC VOLTAGES SHOWN WERE MEASURED WITH AN ELECTRONIC VOLTMETER.
6. "NC"—NO CONNECTION (VOLTAGE SHOWN FOR THIS TERMINAL ONLY WHEN TERMINAL IS USED AS A TIE LUG).
7. "NR"—NOT READABLE (READING GENERALLY MEANINGLESS).
8. " " SPACE PROVIDED FOR SERVICE METER READINGS.
9. ALL READINGS TAKEN WITH LINE PLUG POLARIZED SO THAT GROUND BUSS AND CHASSIS ARE AT THE SAME POTENTIAL WITH THE CHASSIS GROUNDED.

FRONT APRON

BOTTOM VIEW OF CHASSIS

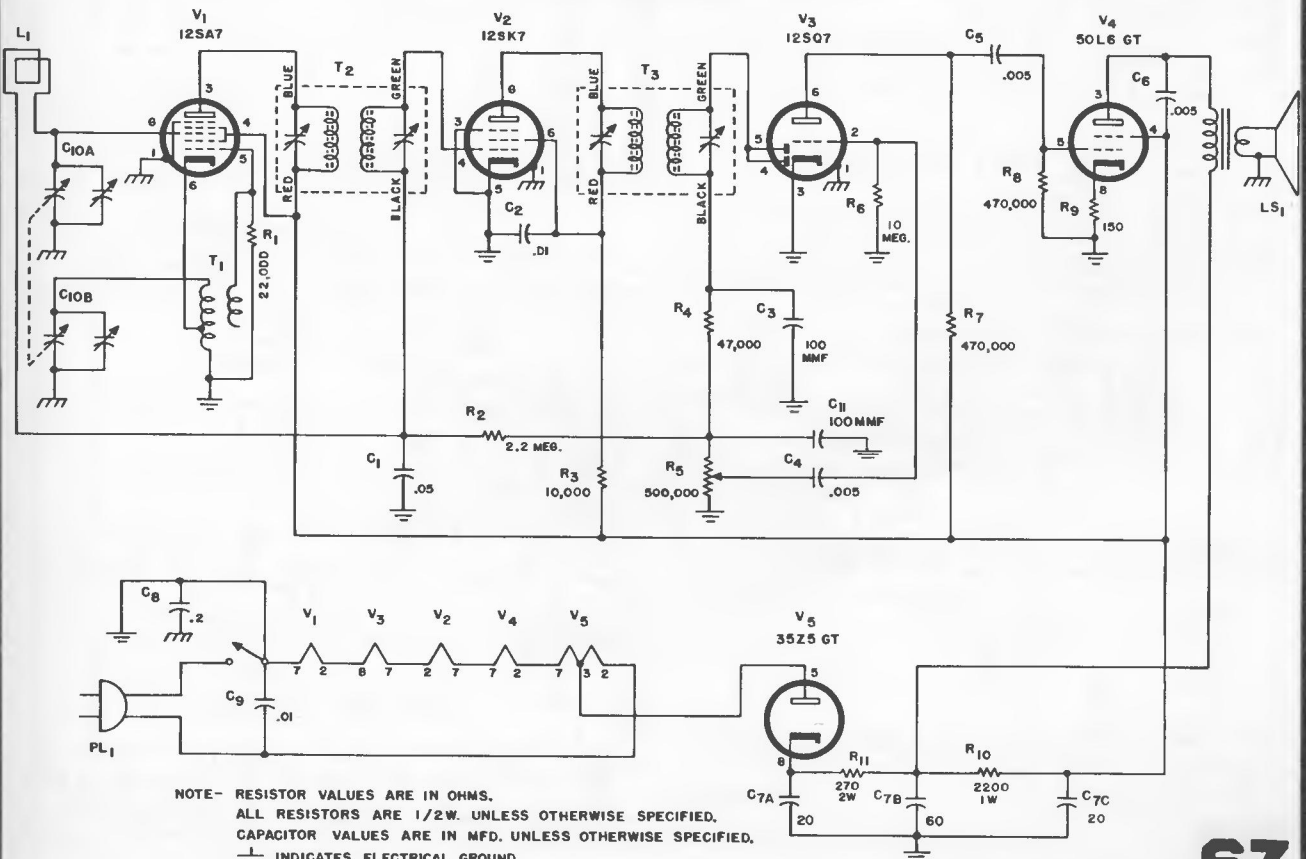

NOTE—RESISTOR VALUES ARE IN OHMS.
ALL RESISTORS ARE 1/2W. UNLESS OTHERWISE SPECIFIED.
CAPACITOR VALUES ARE IN MFD. UNLESS OTHERWISE SPECIFIED.
⊥ INDICATES ELECTRICAL GROUND
⏏ INDICATES CHASSIS GROUND

MANUAL OF 1951 MOST-OFTEN-NEEDED RADIO DIAGRAMS

MONTGOMERY WARD
Models O5BR-2756A, 15BR-2756B,
and 15BR-2757A.

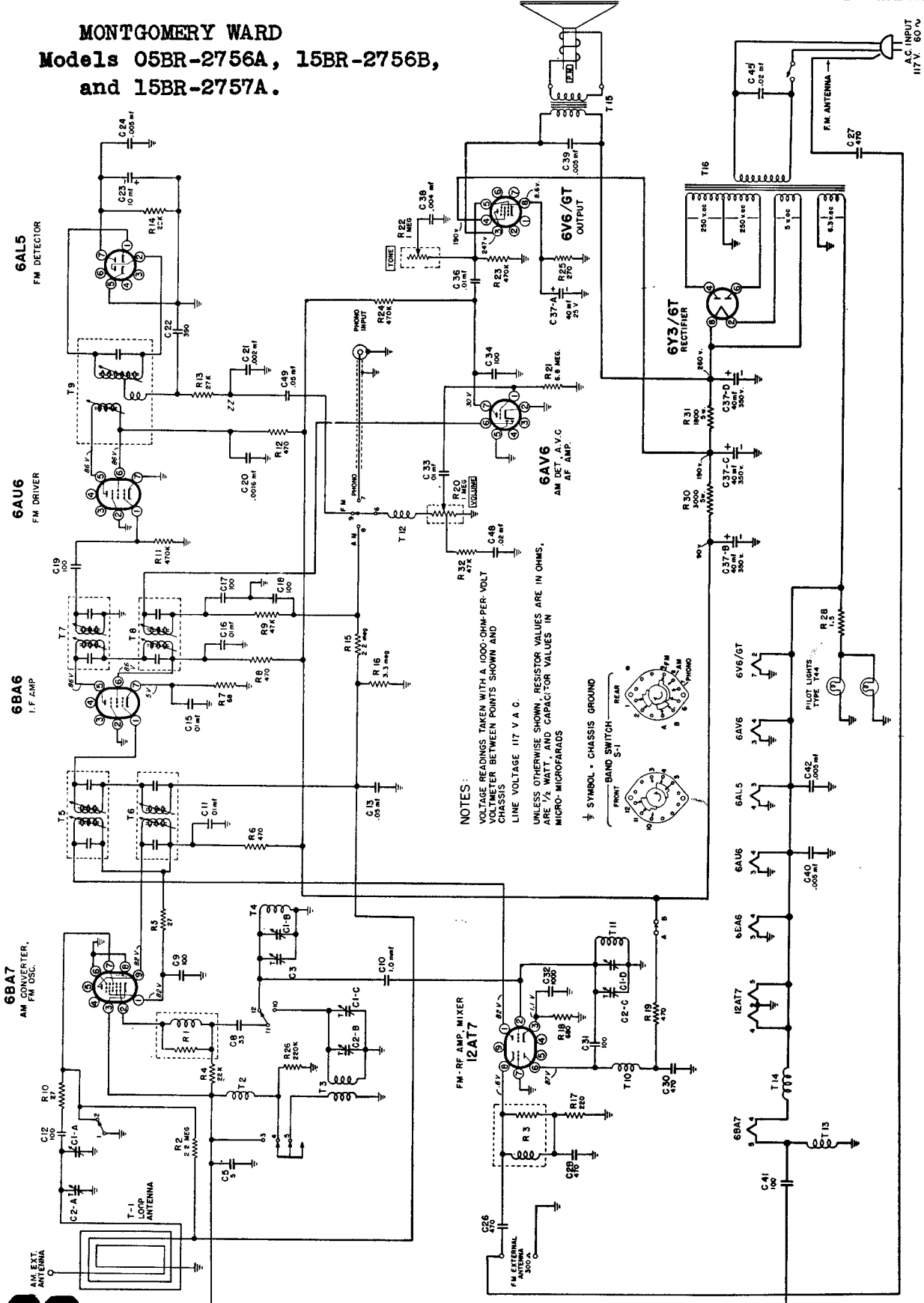

NOTES:
 VOLTAGE READINGS TAKEN WITH A 1000-OHM-PER-VOLT
 VOLTMETER BETWEEN POINTS SHOWN AND
 CHASSIS GROUND
 LINE VOLTAGE 117 V. A. C.
 UNLESS OTHERWISE SHOWN, RESISTOR VALUES ARE IN OHMS,
 ARE 1/2 WATT, AND CAPACITOR VALUES IN
 MICRO-MICROFARADS

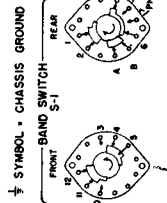

NOTE: Line cord Antenna wire is not electrically connected to the AC plug terminals. Intermediate Freq.....AM-455 kc.; FM-10.7 mc.

Motorola **AUTO** Radio

AUTOMATIC TUNER AT-58

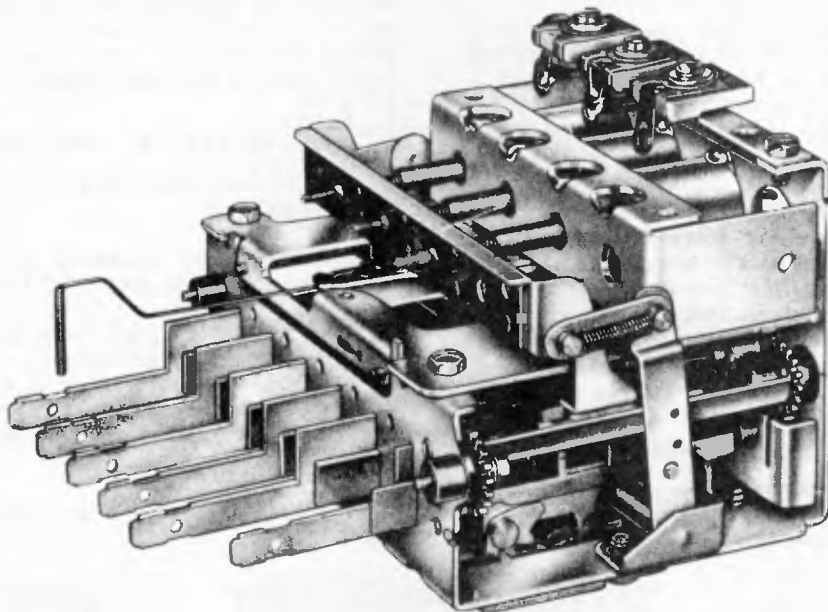

GENERAL INFORMATION

DESCRIPTION

Automatic Tuner AT-58 is used in Motorola specific auto receivers.

This is a 3-gang permeability type tuner, mechanically operated by movement of its push buttons. Five pre-set and one manual tuning positions are provided. The frequency range is 535 to 1600 Kc. The pre-set positions can be set in any sequence to any frequency within this range.

SERVICE TOOLS

The simplicity of the tuner allows easy servicing with:

1. 1/4" open end and 1/4" box end wrench.
2. A stiff steel hook 1/16" diameter made of 1/8" rod, ground down and shaped like a #5 to #10 size crochet hook, to hook and unhook the springs.
3. Slab head wrench for coil adjustment: #2/56 head.

TO REMOVE TOP DECK

Unscrew two #8 sheet metal screws (45) on the back of the tuner and two #8 sheet metal screws (45) on the top front of the tuner. (Do not unscrew screws (45) at trimmer bracket). Before removing

top deck, unhook springs (53) and links (25). Grasp top deck and lift up and tip back. This leaves both decks open for servicing. See Figures 1 and 2.

SERVICING LOWER DECK

Looking at the top of the lower deck (with front to you), on the right we have the manual drive lead screw assembly (42). The other 5 assemblies (43) are the station set-up screw assemblies.

Note that all assemblies can be easily lifted out after springs (50) are unhooked.

Note also that unless a push button arm (1) is pushed in, all assemblies lay flat. When a push button arm (1) is pushed in, the assembly is tilted about 30°.

Visual inspection will show correct location of all springs in the assemblies and those which hold down the assemblies.

(Service material on Tuner AT-58 is continued on the next three pages.)

MANUAL OF 1951 MOST-OFTEN-NEEDED RADIO DIAGRAMS

Motorola Automatic Tuner AT-58, continued from previous page,

Note action of gear train as manual knob is turned and push button arm is pushed in so gears mesh. Automatic tuning buttons can be checked for any binding by trying each button.

DRIVE ARM ADJUSTMENT

It is very important that the carriage drive assembly (12) be correctly adjusted in its bearings so as not to bind or be too loose and allow it to twist and force the tuner out of alignment.

On the left side of the lower deck, you will find a set screw (47) and lock nut (30) for assembly adjustment. Note that the assembly is floated in the base bracket (7) between two ball bearings (4), one on each end. Adjust by loosening lock nut (30) and then turn set screw (47) so that all bearing play is eliminated but yet carriage drive assembly (12) moves freely. Tighten lock nut (30) after adjustment. Before hooking spring (54), tip the tuner several times to make sure carriage drive assembly (12) is free enough to swing up or down by its own weight.

POINTER REPLACEMENT

The pointer is easily removed by downward and outward pressure to unhook it from the pointer arm (2). Pointer is replaced by reversing procedure.

SERVICE INFORMATION

The entire top deck of this tuner may be removed, while tuner is mounted in receiver chassis, allowing complete accessibility to all mechanical parts.

TO REPLACE PARTS ON LOWER DECK

Remove top deck of tuner (follow previous instructions). This exposes the 5-station set up screw assemblies (43) and manual lead screw assembly (42). These may be removed by unhooking springs (50) and lifting them out.

If push button arms or slider arms are to be replaced, it will be necessary to remove spring (54); then take out screws (46) from bottom of tuner to allow bracket (7) to move back and permit push button arm assemblies (1) or slider arms (3) to be removed after springs (53) have been removed.

SERVICE HINTS

1. **STATION DRIFT (Push Buttons).** Check the flat friction spring (56) for breaks or permanent set.
2. **TUNER STICKING.** Check collars on manual drive assembly (42). If they are cocked or stuck, replace with new assembly.
3. **HARD TUNING FOR PRE-SETTING.** Check lubricant on the gear train. It should be Stayput #512 or equal.
4. **TWISTING CARRIAGE PLATE.** Due to poor setting of carriage drive assembly (12). See "Drive Arm Adjustment".

ANT., RF OR OSC. CORE REPLACEMENT

The tuner cores (18) are easily unscrewed from clip (14) and pulled out when carriage assembly (13) is extended. Note that the cores are coded with a paint dot on the screw portion; always use replacement cores bearing the same color coding. When ordering replacement cores, always specify color coding together with part number.

TO SET THE PUSH BUTTONS

1. Turn receiver "on" and allow it to warm up for a few minutes.
2. Push the first automatic tuning button in as far as it will go and HOLD IT THAT WAY.
3. With the tuning knob, tune in the station you desire to set up. Tune carefully until you are exactly on the station; tuning to either side of it will result in poor tone quality. The pointer will indicate station being set up. Release button and knob after tuning in station.
4. Follow above steps 2 and 3 for the remaining four buttons.

Patience is required to assemble push button arm assemblies (1) and slider arms (3) back into bracket (7). Reassemble tuner by working in reverse order.

Test all parts of lower deck for free operation before assembling to upper deck.

TO REPLACE TOP DECK

Make sure that carriage drive assembly (12) is tipped back (spring (54) unhooked) and carriage assembly (13) carrying the tuning cores is out. Slip in the top deck, making sure the spring washer (70) on the manual drive assembly (42) is between the drive assembly gear and the back of the base before putting in screws and locking the two decks together.

5. **ROUGH DRIVE -** Check die cast gears (19, 20 & 21). Check for lubrication (Stayput #512). Check manual drive bushings.
6. **LATCH BAR JAMMING OUT.** Check the latch bar spring (51) on the back. If it is bent out of shape, turn it 180° and reshape. If it is weak-
replace.
7. **STICKING POINTERS.** Check the pointer bearing (6) and make sure the linkage of the assembly is free.
8. **POINTER NOT RE-POSITIONING OR SLOPPY ACTION.** Be sure to check the torsion spring (58) (on the under side of the top deck) for breakage or slipping from the notches on the base and the pointer link plate (34).

MANUAL OF 1951 MOST-OFTEN-NEEDED RADIO DIAGRAMS

Motorola Automatic Tuner AT-58, continued

(Service instructions given on the previous two pages; Figure 2, showing location of additional parts is on the next page, over).

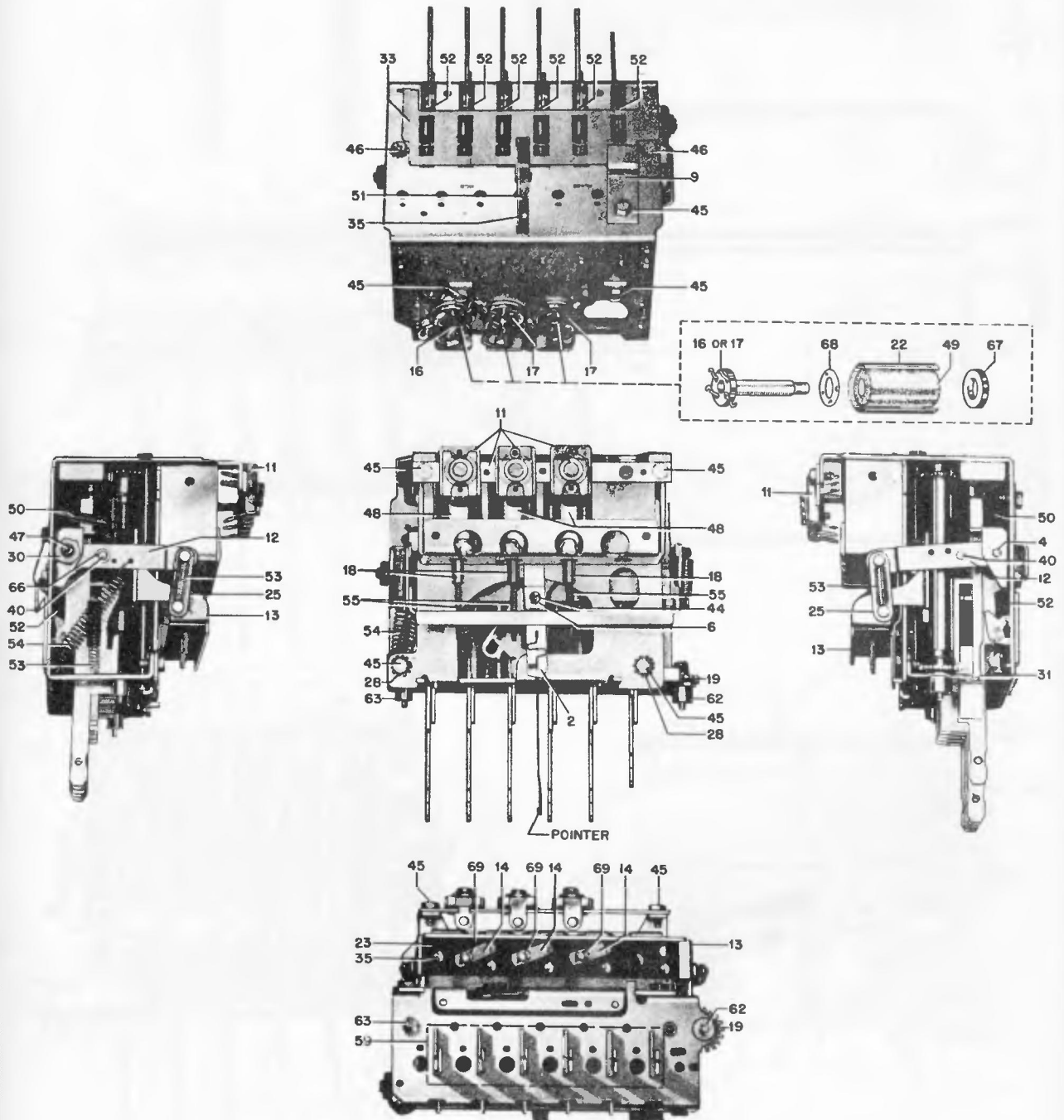

FIGURE 1. AUTOMATIC TUNER AT-58 PARTS LOCATIONS

MANUAL OF 1951 MOST-OFTEN-NEEDED RADIO DIAGRAMS

Motorola Automatic Tuner AT-58, continued

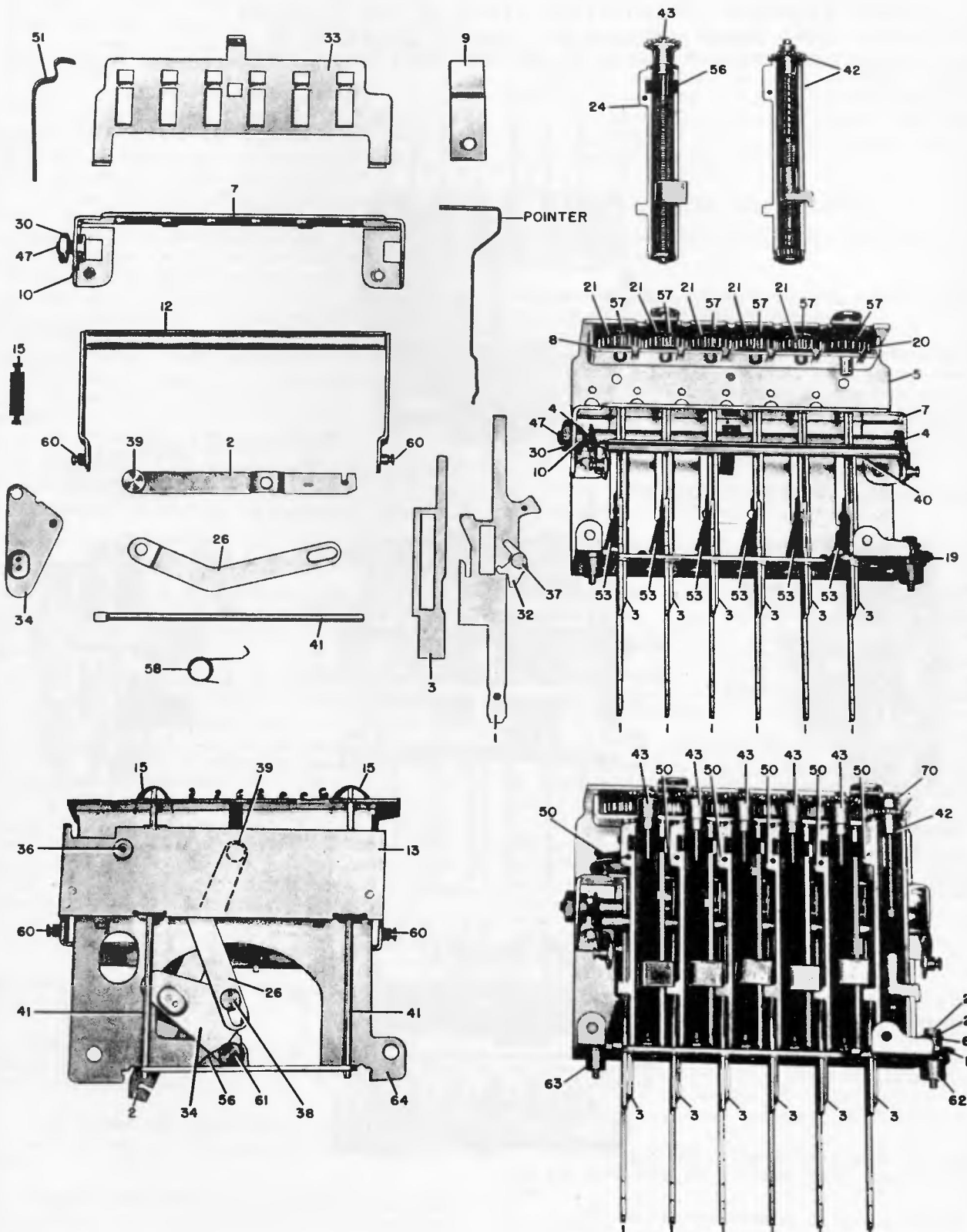

FIGURE 2. AUTOMATIC TUNER AT-58 PARTS LOCATION

MANUAL OF 1951 MOST-OFTEN-NEEDED RADIO DIAGRAMS

Motorola Inc. CHASSIS **1A**

MODEL **KR1**
CT1

VOLTAGE READINGS SHOWN WERE MEASURED FROM POINT INDICATED TO CHASSIS GROUND WITH A VTVM. NO SIGNAL WAS TUNED IN. ALL VOLTAGE READINGS ARE AT 6.3 V. DC AT 80% RECEPTABLE VOLTAGE. TOLERANCE ± 10%.

NOTES
ALL RESISTORS ARE INDICATED IN OHMS.
ALL CAPACITORS ARE INDICATED IN MMF UNLESS OTHERWISE SPECIFIED.

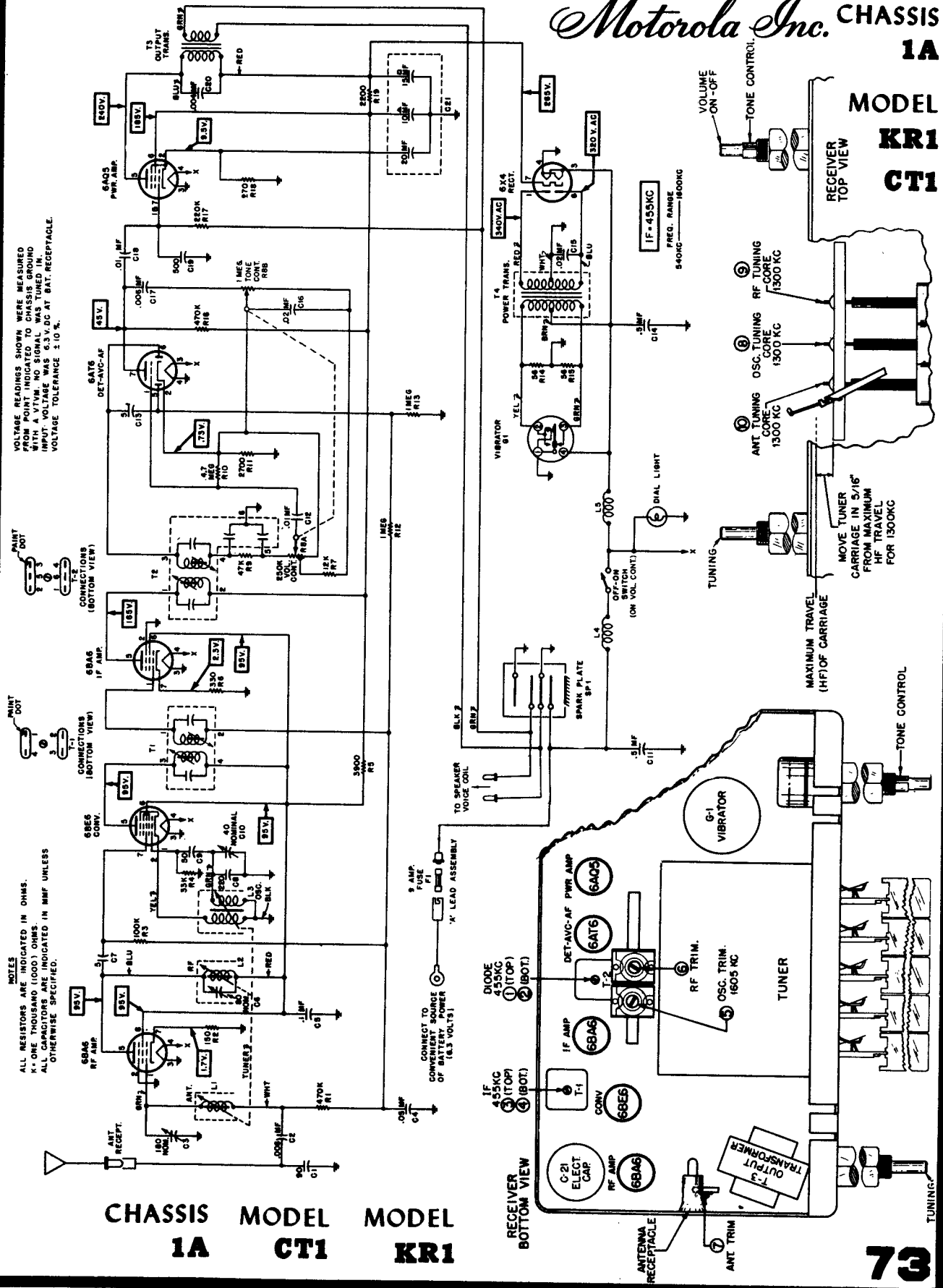

CHASSIS MODEL **1A** MODEL **KR1**
CT1

RECEIVER **BOTTOM VIEW**

TUNER

MANUAL OF 1951 MOST-OFTEN-NEEDED RADIO DIAGRAMS

Motorola Inc.

CHASSIS
1B

MODEL
SR1B

Model CT1M designed for 1951 Chevrolet
uses almost the identical circuit.

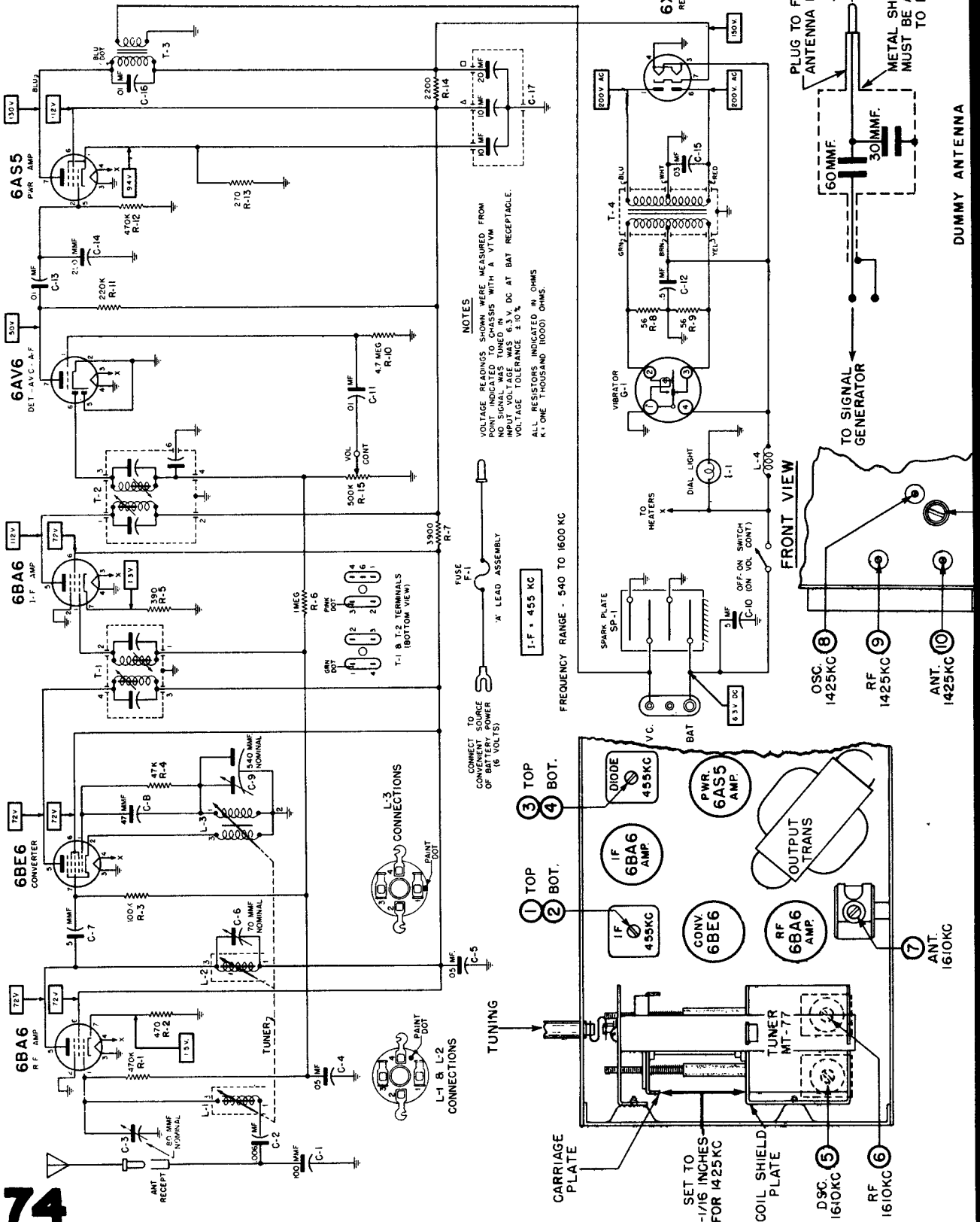

MANUAL OF 1951 MOST-OFTEN-NEEDED RADIO DIAGRAMS

Motorola

TYPE - Specifically designed for installation in the 1951 Nash (Rambler Series cars only).

MODEL NH1C

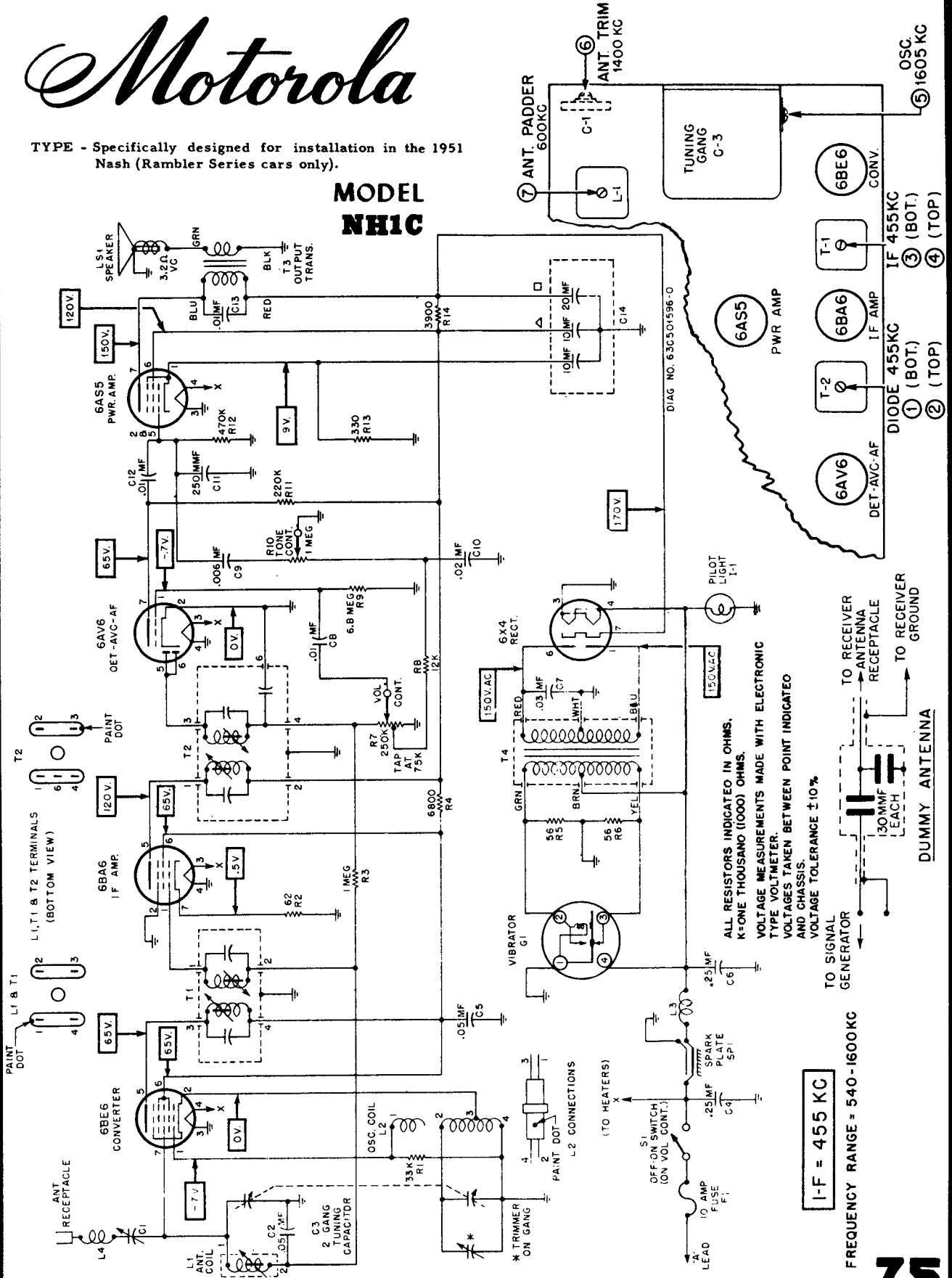

I-F = 455 KC

FREQUENCY RANGE = 540-1600 KC

MANUAL OF 1951 MOST-OFTEN-NEEDED RADIO DIAGRAMS

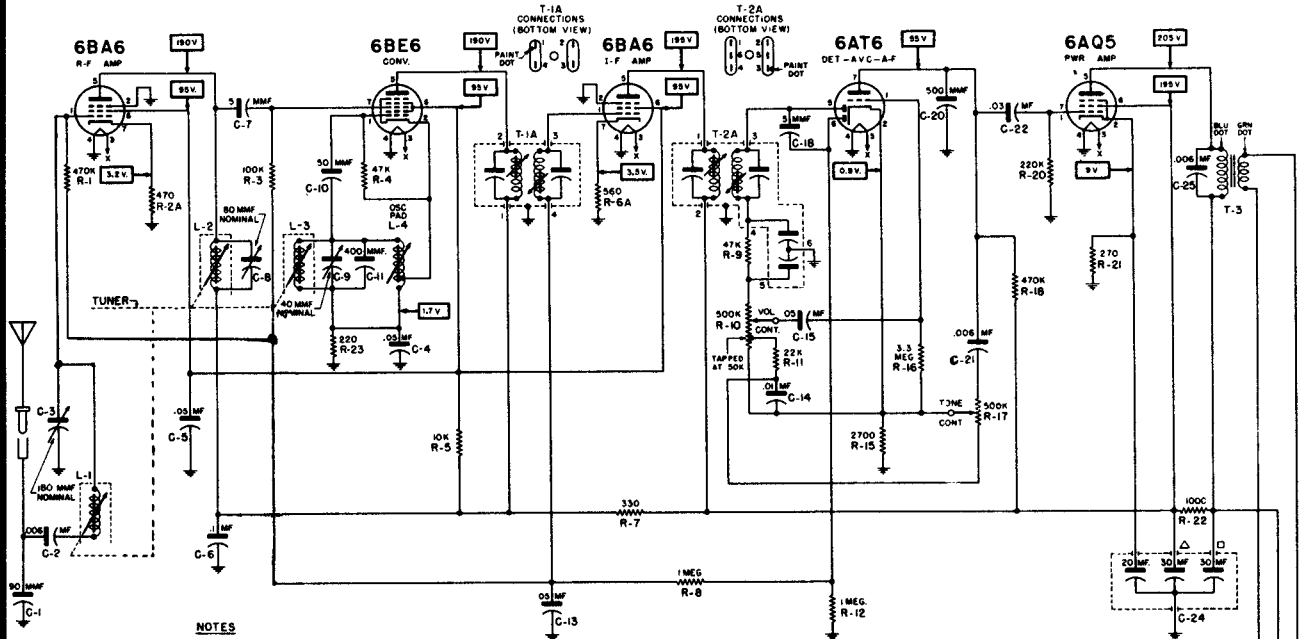

NOTES

VOLTAGE READINGS SHOWN WERE MEASURED FROM POINT INDICATED BY CHASSIS WITH A VTVM NO SIGNAL WAS TUNED IN INPUT VOLTAGE WAS 6.3V. DC AT BAT RECEPTACLE. VOLTAGE TOLERANCE $\pm 10\%$. ALL RESISTORS INDICATED IN OHMS $\times 1,000$ (1000) OHMS



I-F = 455 KC

FREQUENCY RANGE - 535 TO 1600 KC

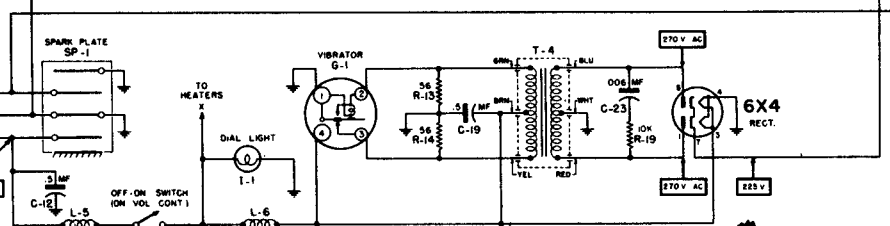

MODELS

- BKOA
- CT8A
- GM9TA
- GMOT
- HNO
- ILOTG
- KR9A
- OEO
- PCO
- PC9A
- SR9A

Motorola Inc.

CHASSIS 10A

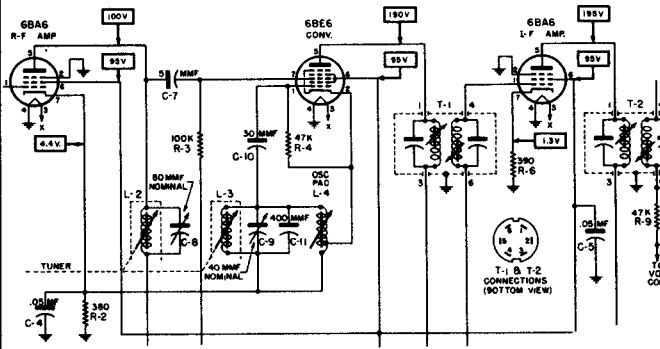
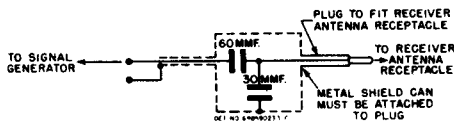
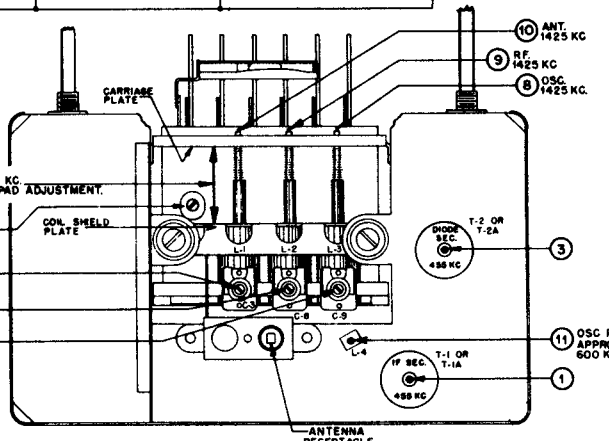

OLD IF CIRCUIT

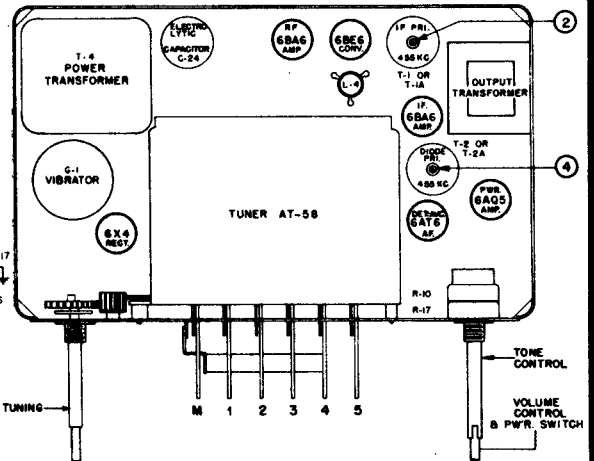

MANUAL OF 1951 MOST-OFTEN-NEEDED RADIO DIAGRAMS

Motorola

Model 701 circuit is shown on this page.

Model 801 tuner unit is as shown, while the audio unit differs mainly in using two 6AQ5 tubes in the output stage.

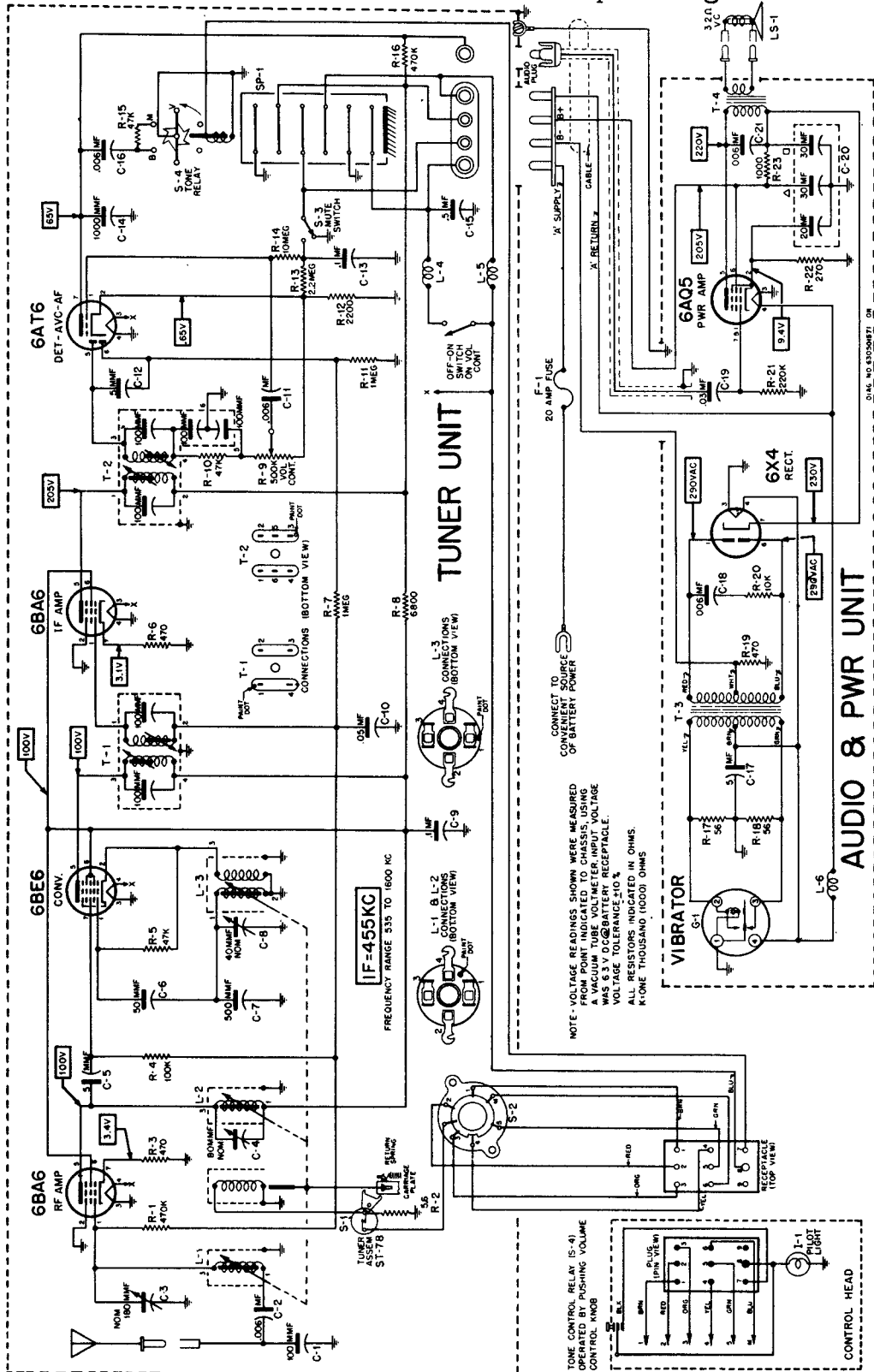

MANUAL OF 1951 MOST-OFTEN-NEEDED RADIO DIAGRAMS

Motorola Inc.

Models 401 and 451

Model 401 uses a self-contained speaker and its circuit is exactly as shown on this page. Model 451 employs an external speaker, but is the same as the 401 in all other respects.

NOTE—
CAPACITORS INDICATED IN MMF UNLESS OTHERWISE SPECIFIED
ALL RESISTOR INDICATED IN OHMS
K—ONE THOUSAND (000) OHMS
VOLTAGE MEASUREMENTS MADE WITH ELECTRONIC TYPE VOLTMETER
VOLTAGES TAKEN BETWEEN POINT INDICATED AND GROUND
VOLTAGE TOLERANCE ±10%
MAY VOLTAGE 7V DC
NO SIGNAL INPUT

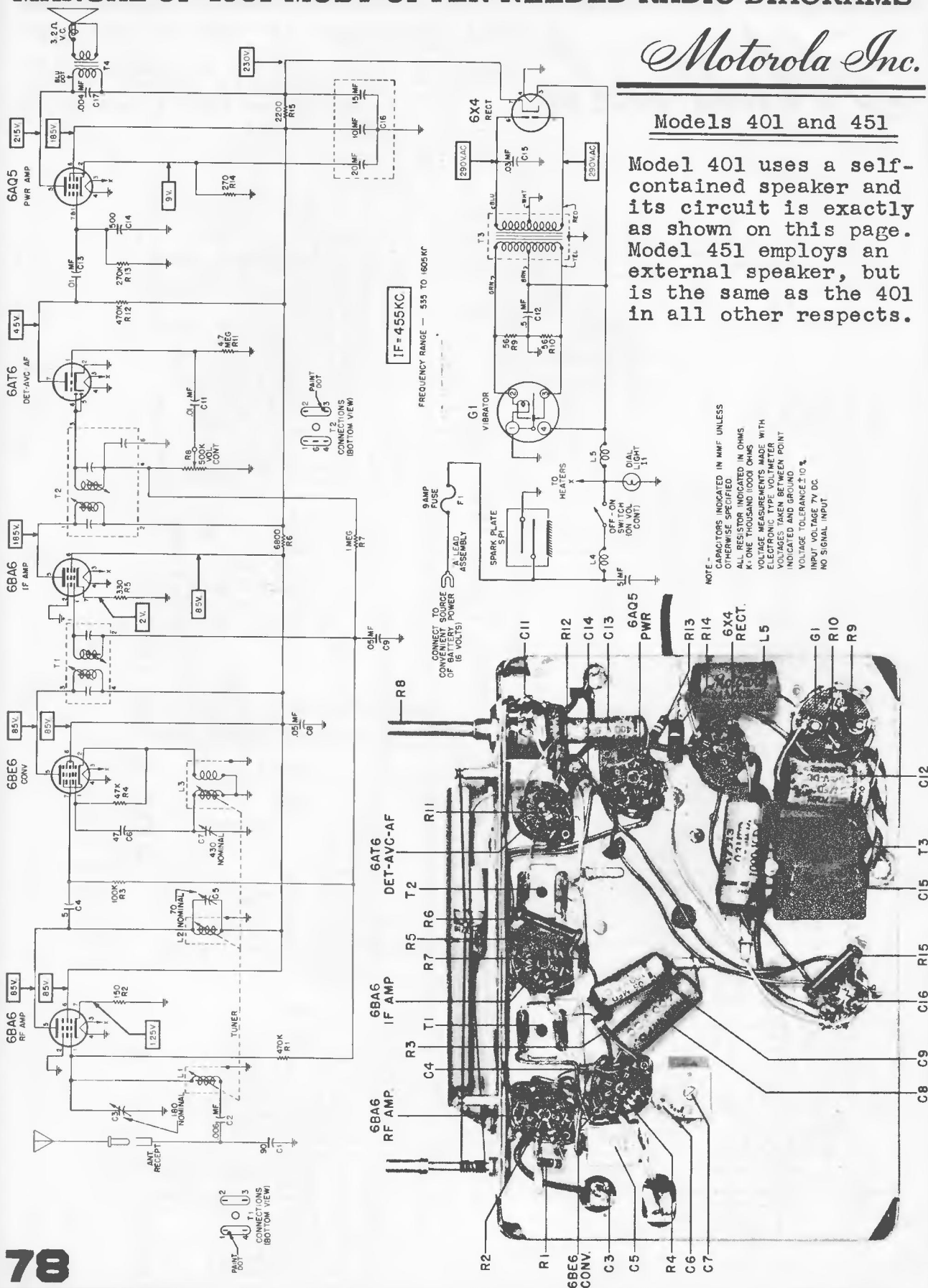

MANUAL OF 1951 MOST-OFTEN-NEEDED RADIO DIAGRAMS

Motorola

Model 501, with self-contained speaker, is exactly as per diagram.

Model 601, differs only in the use of an external loud-speaker.

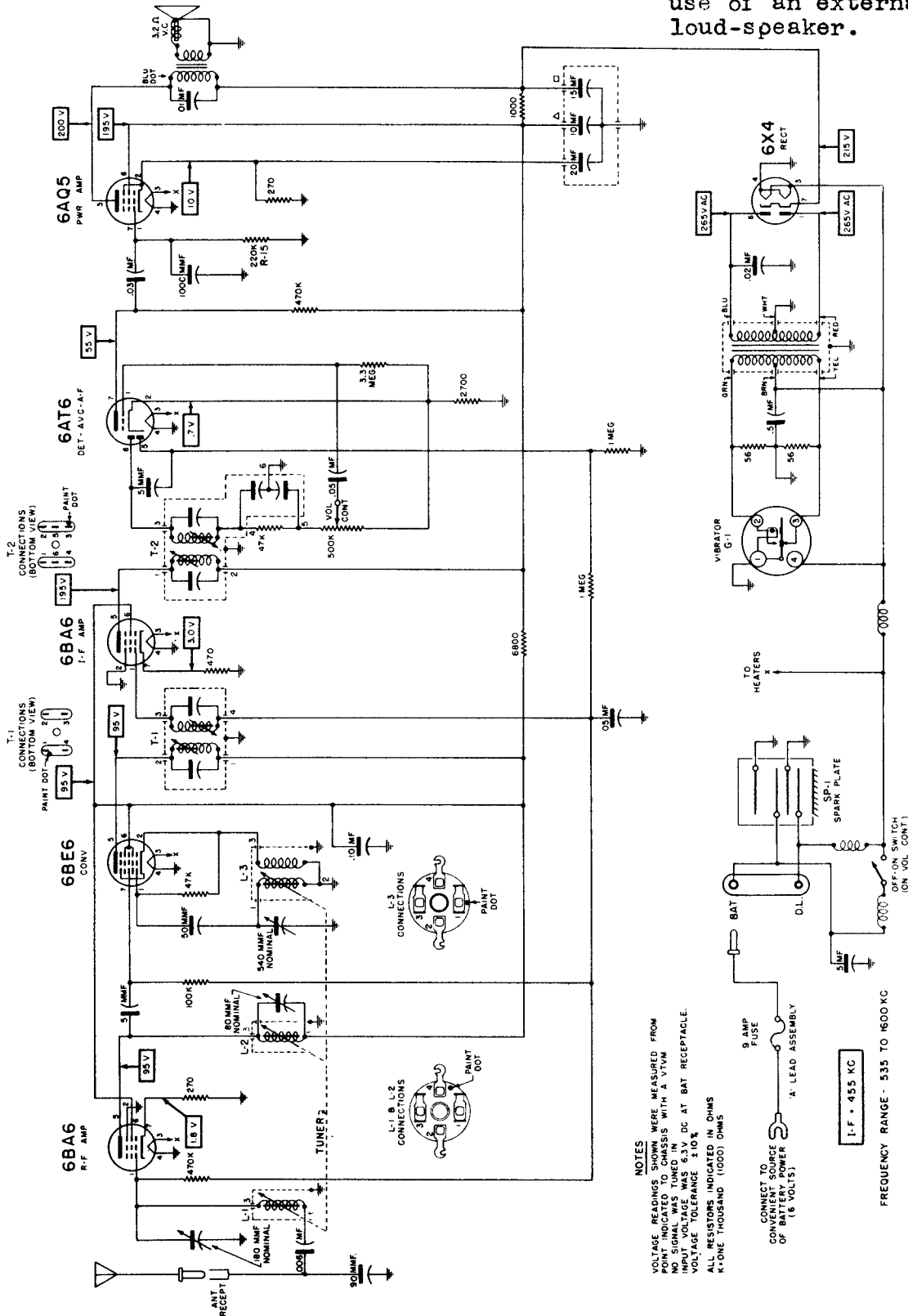

NOTES
 VOLTAGE READINGS SHOWN WERE MEASURED FROM POINTS INDICATED BY THE ARROWS. ANALYSIS WITH A VTVM NOT SHOWN. SIGNALS TUNED IN.
 INPUT VOLTAGE WAS 6.3V DC AT BAT RECEPTACLE.
 VOLTAGE TOLERANCE ±1.0%
 ALL RESISTORS INDICATED IN OHMS
 K=ONE THOUSAND (1000) OHMS

CONNECT TO CONVENIENT SOURCE OF BATTERY POWER (6 VOLTS)
 9 AMP FUSE
 'A' LEAD ASSEMBLY
 SPARK PLATE
 TO HEATERS
 VIBRATOR G-1
 6X4 RECT
 285V AC

FREQUENCY RANGE - 535 TO 1600 KC
 I-F - 455 KC
 OFF-ON SWITCH (ON VOL CONT.)

Motorola **AUTO** Radio

Two-piece automotive type receiver, specifically designed for installation in Plymouth P-22 and P-23 cars.

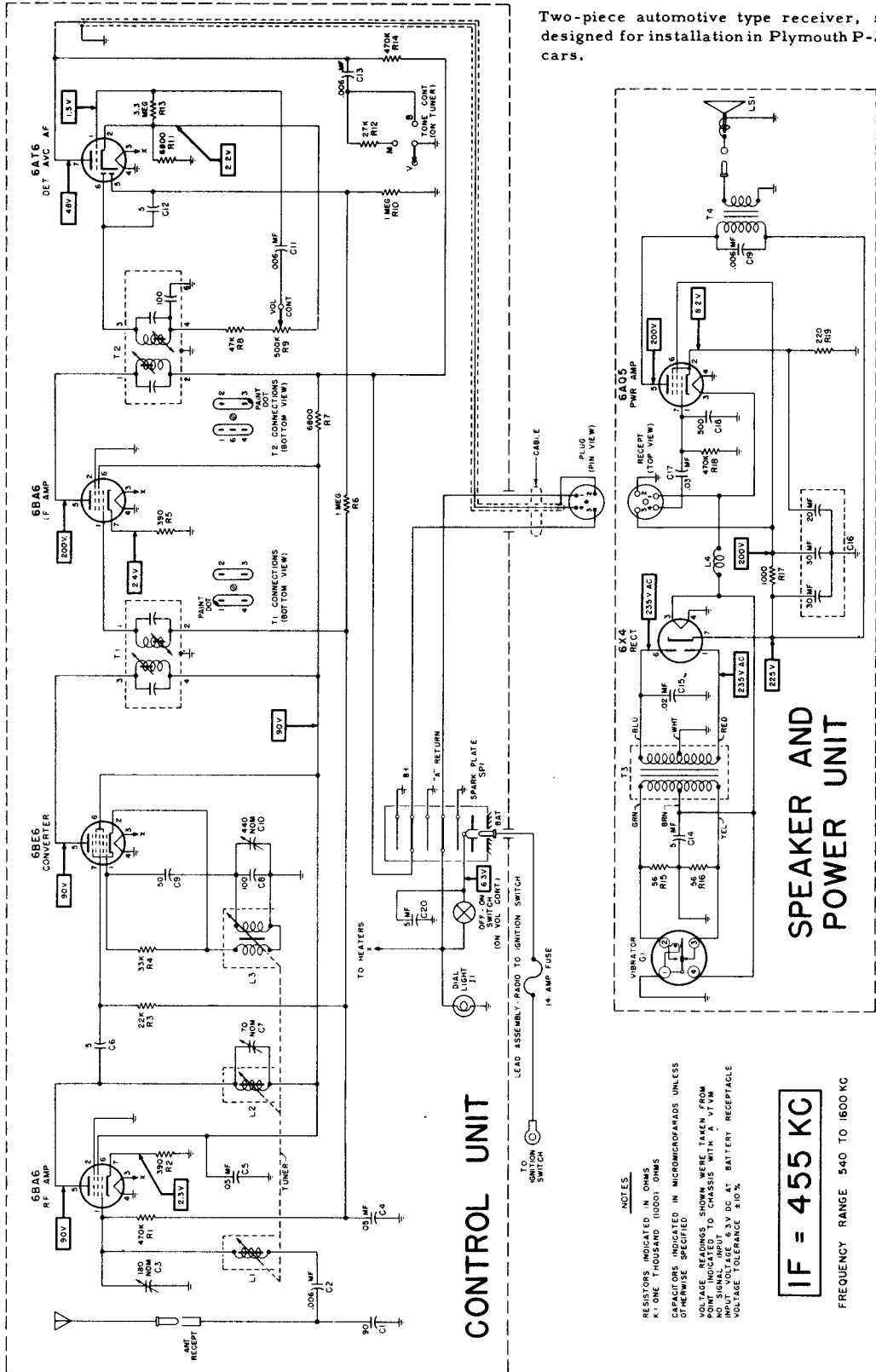

MANUAL OF 1951 MOST-OFTEN-NEEDED RADIO DIAGRAMS

Motorola **AUTO** Radio SERVICE MANUAL

SOLENOID
TUNER

MODELS
ST-60
ST-78

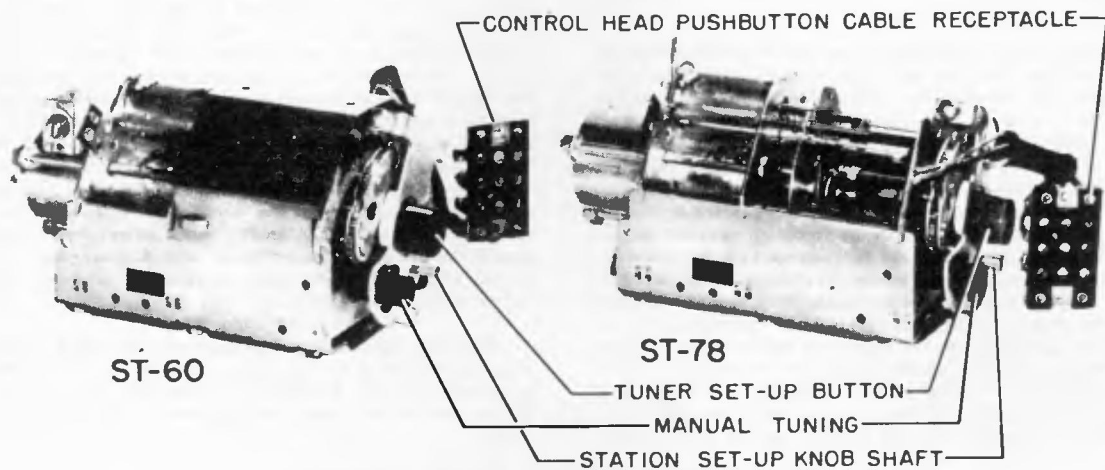

GENERAL

Solenoid Tuners ST-60 and ST-78 are used in Motorola electric push-button standard auto receivers.

Fundamentally ST-60 and ST-78 tuners are the same. The two tuners differ in push-button switch lead lengths, oscillator coil, sleeve and shield, tuning cores, antenna trimmer and cover over ST-60 carriage. These tuners are similar to the original Motorola ST-54 solenoid tuner.

This is a 3 gang permeability type tuner operated by a solenoid. Five pre-set and one manual tuning positions are provided. The frequency range is 535 to 1600 kc. The pre-set positions can be set to any frequency within this range.

The tuner is designed to operate satisfactorily with 4.5 to 7.3 volts input. Before attempting any service work on a tuner that operates too slowly or one that doesn't operate at all, check the battery voltage directly at the receiver

spark plate. Normally, this voltage is 6.3 volts. At the moment any push-button is pressed, the voltage at the spark plate should not drop to less than 4.5 volts. If the voltage is less than 4.5, it is an indication of poor wiring between the car battery and receiver or a defective car battery.

This tuner depends on "dash-pot" action between the plunger and the solenoid for proper operation. When the fit between the plunger and solenoid is too tight, the air can't get out fast enough. The result is a slow or sluggish operating tuner. All ST-60 and ST-78 tuners have an adjustable air release in the solenoid end plate. See Figures 1 & 3.

The tuner solenoid coil must be in a horizontal or near horizontal position or the tuner will not operate properly. If it is operated with the coil in a vertical position, the solenoid and carriage return spring may not be strong enough to operate the tuner.

TO SET UP AUTOMATIC TUNER

- a. Turn receiver on and allow it to warm up for a few minutes.
- h. Collapse antenna until signal is weak.
- c. Press Manual "M" button on control head.
- d. Turn tuning knob until desired station is tuned in. (Make a mental note of the program). For best results choose only local stations.
- e. Press desired button and wait until tuning mechanism completes its operation.
- f. Press automatic tuner set-up button until "click" is heard. (See detail above.)
- g. Turn automatic tuner set-up knob until previously noted program is heard. NOTE: Check the setting of the automatic button just set up by pressing the "M" button and manually tune in the station. There should be no difference in volume or clarity when the station is tuned in either manually or automatically. If a difference is noted, reset the automatic tuner push button more accurately by repeating above procedure. Also make sure the push button is set to same station that was selected manually and not to a weak distant station carrying the same network program.
- h. Repeat steps c, d, e, f and g for balance of buttons.

(This material is continued on the following pages through page 86.)

MANUAL OF 1951 MOST-OFTEN-NEEDED RADIO DIAGRAMS

MOTOROLA Auto Radio Solenoid Tuner, Models ST-60 and ST-78, continued.

THEORY OF OPERATION

NOTE: Throughout these paragraphs, it is suggested that constant reference be made to Figure 1.

When any push-button is pressed, current flows through the solenoid coil, causing the plunger to pull into the coil. Near the end of the plunger travel, through a ratchet mechanism inside the plunger, the selector switch shaft is rotated 60° , moving the selector switch and stop plate to their new position.

An instant later, the solenoid switch is opened breaking solenoid current and the carriage return spring then pulls the plunger out, closing the solenoid switch again. If the selector switch is now resting at the position selected by the push-button (cut away section of selector switch resting in front of contact selected by push-button), the solenoid plunger will continue to be pulled out until the stop plate is resting on the selected lead screw stop. In the event the selector switch is not resting in the position selected by the push-button when the solenoid plunger is on its return trip, the moment the plunger moves out far enough to actuate the solenoid switch, current will again flow through solenoid causing the plunger to be pulled in again. The plungers inward motion again rotates the stop plate and selector switch through another 60° . This last operation is repeated automatically until the selector switch comes to rest at the position selected by the push-button, at which time the solenoid circuit is opened and the plunger moves out until the

stop plate is resting on the selected lead screw stop. The stops are adjusted to the desired positions during the station setting up procedure, through the set-up gear train assembly.

Refer to Figure 2 for mechanics behind station setting-up mechanism detail.

When the button on which a station is to be set up is first pressed, the tuner operates and the stop plate comes to rest against the selected lead screw stop. The pressure of the stop plate against the lead screw stop moves the lead screw forward until its shoulder rests against the tuner end plate. The square end of the lead screw does not engage in the square hole of the set-up gear until the set-up button is pushed in and the station set-up knob is turned. A latch on one end of the detent lever engages the gear lever, holding the set-up gear train in contact with the selected lead screw. Now the selected lead screw stop can be moved on its lead screw by turning the station set-up knob. None of the other lead screws turn because the stop plate is not resting against them. After the button is set up, pressing any other button will unlatch the gear lever and disengage the lead screw from the set-up gear. See Figure 2.

Since the coil tuning iron cores are attached to the carriage plate and move in unison with the plunger, the point at which they are brought to a stop (by means of the lead screw stop) determines the frequency to which the coils are tuned.

TO REMOVE TUNER FROM CHASSIS

Should it become necessary to remove the solenoid tuner from the receiver chassis, proceed as follows:

1. Remove the covers from the set, completely exposing the chassis.
2. Mark all leads connecting tuner to receiver.

3. Disconnect all leads connecting tuner to receiver. The control head connecting receptacle is to be removed by unscrewing the two self-tapping screws. Do not unsolder leads from the tuner selector switch.

4. The tuner is held to the chassis by self-tapping screws driven into the sides of the tuner. Do not remove any other screws.

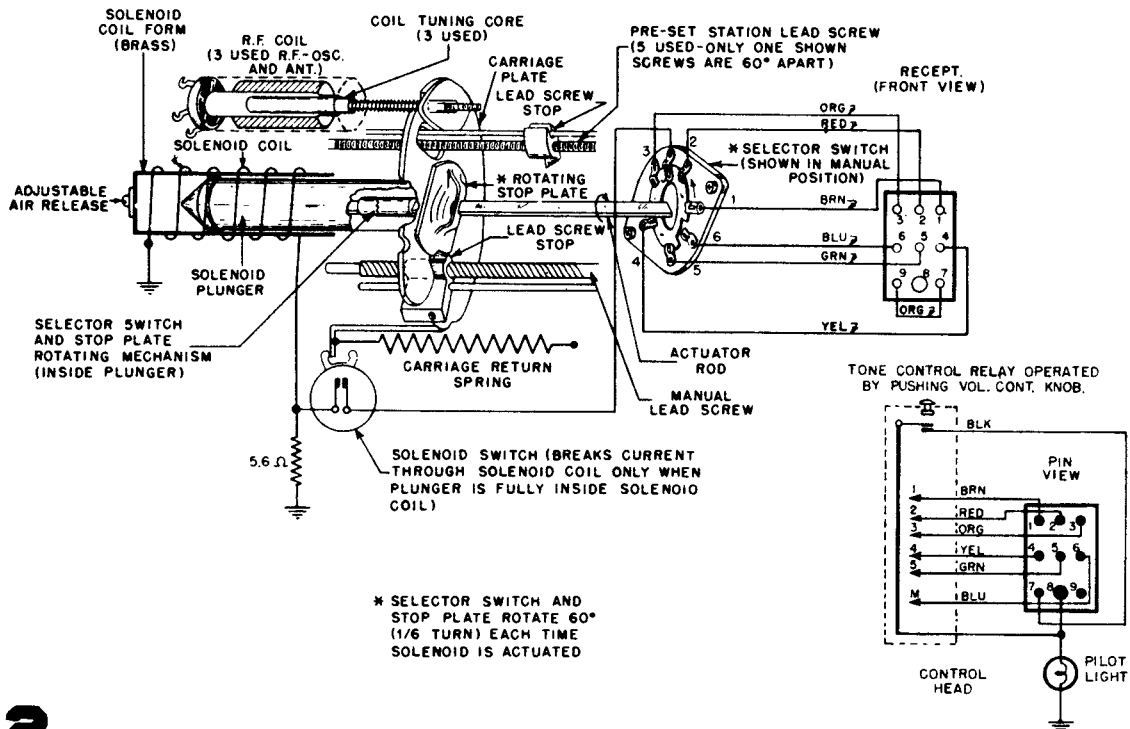

FIGURE 1. TUNER FUNCTIONAL DETAIL

MANUAL OF 1951 MOST-OFTEN-NEEDED RADIO DIAGRAMS

MOTOROLA Solenoid Tuner, Models ST-60 and ST-78, continued.

1.

POSITION OF LEAD SCREW WHEN STOP PLATE IS NOT RESTING ON SELECTED LEAD SCREW STOP.

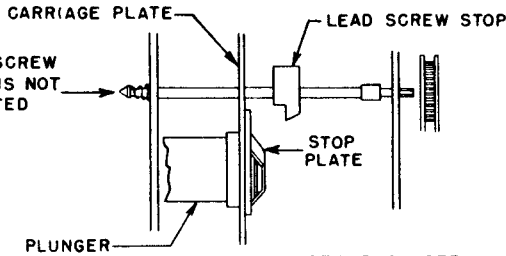

2.

POSITION WHEN STOP PLATE IS RESTING AGAINST LEAD SCREW STOP.

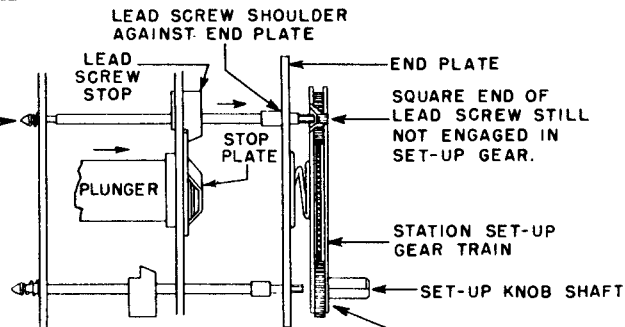

3.

SELECTED LEAD SCREW NOW ENGAGED IN SET-UP GEAR.

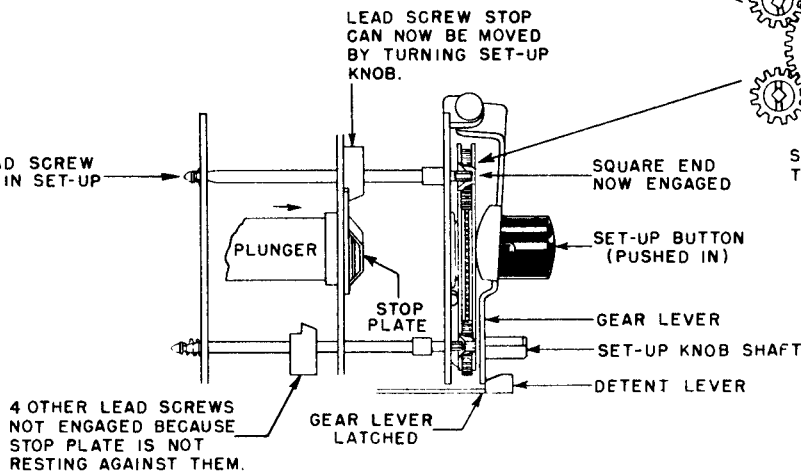

4.

AFTER STATION IS SET UP GEAR LEVER IS UNLATCHED BY PRESSING A BUTTON

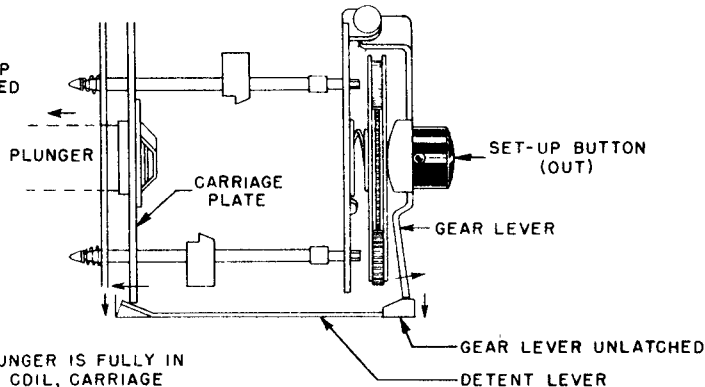

WHEN PLUNGER IS FULLY IN SOLENOID COIL, CARRIAGE PLATE RELEASES GEAR LEVER AS SHOWN, DISENGAGING LEAD SCREW FROM SET-UP GEAR.

FIGURE 2. STATION SET-UP MECHANISM

MANUAL OF 1951 MOST-OFTEN-NEEDED RADIO DIAGRAMS

MOTOROLA Auto Radio Solenoid Tuner Models ST-60 and ST-78, continued.

ADJUSTMENTS

AIR RELEASE ADJUSTMENT

The speed at which the tuner operates is governed by dash-pot action of the solenoid plunger within the closed solenoid coil form. The rate at which air is allowed to enter or escape determines the speed of the plunger.

An adjustable air release is provided on all ST-60 and ST-78 tuners. See Fig. 3. To adjust, loosen the screw and move the eccentric washer which covers the air release hole to expose or cover more of the air release hole as required.

1. If tuner operates too slowly, open the air release hole. Open it only far enough to secure reliable operation. Too little "dash-pot" action (air release open too much) may cause the plunger to hammer and sometimes even to make the tuner operate continuously due to the selector switch rotor being turned so rapidly as to overshoot its contacts.
2. If the tuner operates too rapidly increase dash-pot action by closing the air release hole slightly. Close it only enough to eliminate hammering.

PLUNGER RATCHET ADJUSTMENT

The plunger ratchet mechanism is shown in Figure 4. This mechanism rotates the actuator rod which, in turn, rotates the carriage stop plate and the selector switch 60° for each inward motion of the plunger.

If this adjustment is incorrect, tuner may operate continuously once current is applied.

Correct ratchet adjustment is indicated when 1/64" to 1/32" clearance is observed between selector switch contacts and the selector switch rotor as shown in Figure 5. Slowly work the plunger by hand and observe clearance at each contact position. If the average clearance is not 1/64" to 1/32", correction can be made by loosening ratchet adjustment setscrew and turning actuator rod by hand until correct clearance is observed.

Before ratchet adjustment setscrew is finally tightened, push fixed ratchet 1/32" back into plunger. This increases spring tension against rotating ratchet, thus insuring more positive operation.

SOLENOID SWITCH TRIP ADJUSTMENT

The solenoid switch tripping mechanism should be adjusted as shown in Figure 6.

If the solenoid switch is tripped too early, the ratchet mechanism may fail to operate; if it trips too late, the plunger may hammer violently or should the solenoid switch fail to trip, the plunger would be held within the solenoid.

FAILURE OF SOME LEAD SCREW TO ENGAGE IN SET-UP GEARS

If some of the lead screws fail to engage in the set-up gears during station setting up procedure, check the gear lever to see if it is bent. When the set-up button is pushed in and the gear lever latches on the detent lever, the set-up gear train should be parallel with the tuner end plate and the bottom of the gear train should be resting on the raised portions of the tuner end plate.

END VIEW OF TUNER

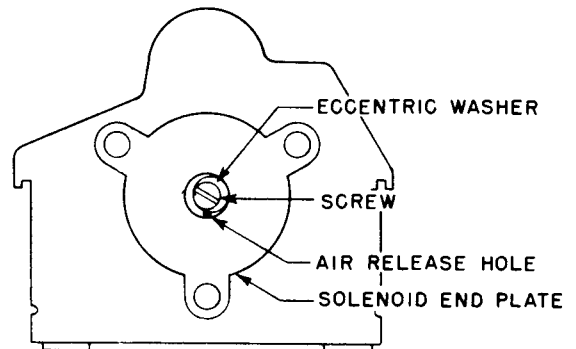

FIGURE 3. AIR RELEASE ADJUSTMENT

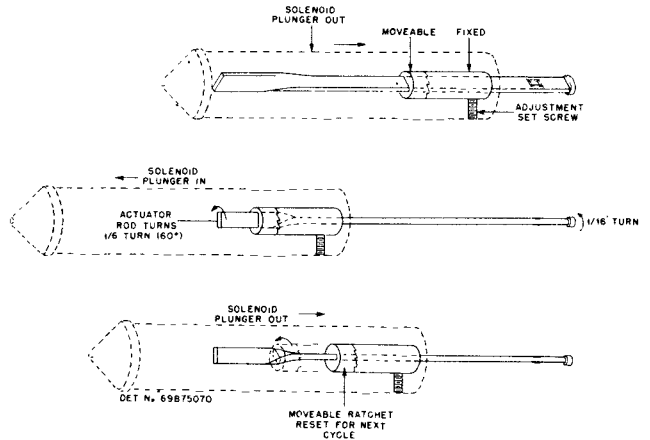

FIGURE 4. PLUNGER RATCHET MECHANISM

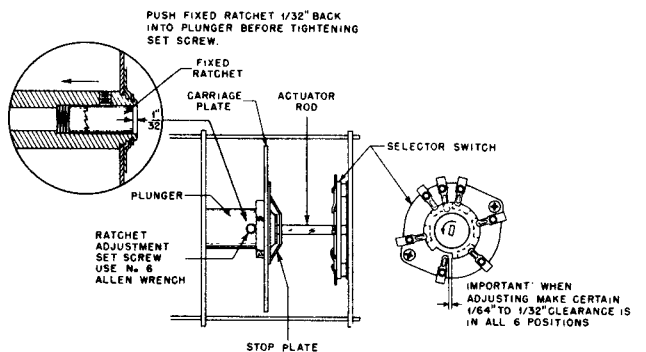

FIGURE 5. PLUNGER RATCHET ADJUSTMENT

SERVICE NOTES

LUBRICATION

Should lubrication ever be required, it is recommended that a very fine grease, commercially called DOW-CORNING Silicone (DC 44 Medium Grade), or its equivalent be used.

Remove all old and sticky lubricant with a solvent such as carbon tetrachloride and then, very sparingly, lubricate only the following points:

1. Carriage guide rods.
2. Actuator rod.
3. Manual lead screw.

Do not lubricate or permit lubricant to get on Selector Switch contacts.

MANUAL OF 1951 MOST-OFTEN-NEEDED RADIO DIAGRAMS

MOTOROLA Tuner ST-60, ST-78, continued.

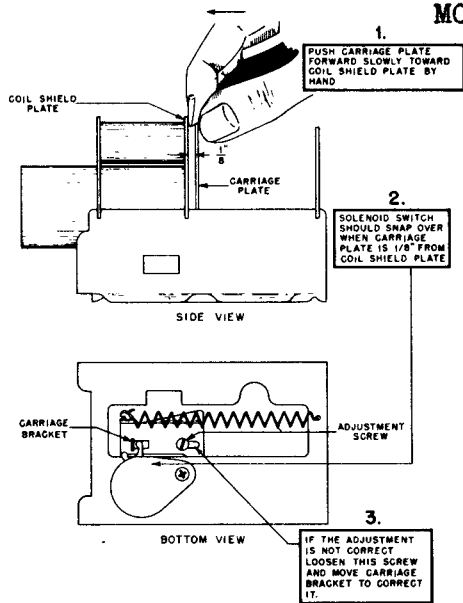

FIGURE 6. SOLENOID SWITCH ADJUSTMENT

LEAD DRESSING

Make sure that the selector switch and solenoid coil leads are dressed so that carriage plate does not rub against them. Leads rubbing against the carriage plate may cause the tuner to stick, especially at the high frequency end.

REPLACEMENT OF SOLENOID COIL OR SOLENOID PLUNGER

Should replacement of the solenoid coil or solenoid plunger be required, it will be necessary to replace the entire tuner. A close fit between solenoid plunger and solenoid coil form is required; a proper match can only be secured at the factory. When service of this kind is required, return the tuner to the factory for exchange.

ALIGNMENT

In the event that some part of the R. F. circuit has been changed or the adjustments shifted by mishandling, it is suggested that the receiver be realigned. Follow the alignment instructions found in the receiver service manual.

The tuner must be in good working order and assembled onto the chassis before attempting alignment of its tuned circuits.

TO REPLACE ANT. R. F., OR OSC. COILS

1. Unsolder the two lugs holding the coil to the tuner plate.
2. Carefully remove the old coil. Save the thin paper washer that is found at the base of the coil.
3. Slip the paper washer over the replacement coil and slip coil into shield can.
4. Orient coil so its lugs are in same position as before and resolder to tuner plate.
5. Reassemble tuner and install in receiver.
6. Realign ANT., R. F. and OSC. stages per instructions found in the receiver service manual.

ADJUSTMENT OF GEAR LEVER LATCH

The gear lever latch holds the station set-up gear train in position while setting up stations. Failure of the latch to engage properly when the set-up button is pushed in will result in the inability to set up pre-set stations. Failure of the latch to disengage after station is set-up will result in faulty automatic tuning because the lead screws might not seat themselves properly against the tuner end plate. Figure 7 shows the latch detail and adjustment.

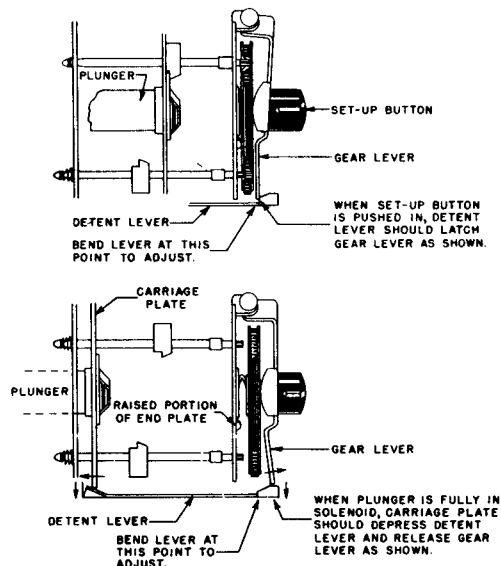

FIGURE 7. GEAR LEVER LATCH ADJUSTMENT

TO REPLACE ANT. R. F. OR OSC. COIL TUNING CORES

1. Remove the carriage return spring.
2. Move the carriage plate back as far as it can go. The tuning cores can now be screwed "out" or "in" by grasping the portion that sticks out the back of the coil. When installing a new core, make sure that the insulating washer and adjustment clip are replaced properly. The insulating washer goes on the core side; the core adjustment clip has an ear on it and this ear must fit into a hole in the bakelite insulator on the carriage plate. Refer to Figure 8.
3. Replace the carriage return spring.
4. Install tuner in receiver.
5. Realign ANT., R. F. and OSC. stages following the instructions found in the receiver service manual.

PLUNGER RATCHET REMOVAL

To remove ratchets, proceed as follows:
(Refer to Figure 8 for parts identification).

1. Remove gear plate mounting screw (55).
2. Pull out actuator rod (46). Don't lose washers (83), (88) and (89).
3. Remove stop plate bracket (4) by sliding it out of the retaining slots.
4. Loosen setscrew (50).
5. The large fixed ratchet (34), small floating ratchet (35) and ratchet spring (70) can now be removed.
6. Reassemble in reverse order.

TUNER HANGS UP

The beginning of this trouble is usually a condition where the tuner "runs wild" (fails to stop at a station). Eventually, the stop plate gets "hung up" by getting on the wrong side of the station stops (56). The cause of the trouble is that the selector switch (74) does not turn the correct amount with each dash of the plunger.

Since the actuator rod (46) determines the rotation of the selector switch, it is usually at fault. Check the twist in the actuator rod. It should be 82 degrees. Also check the fit between the "head" end of the actuator rod (46) and the rotary section of the selector switch (77). We have found that some sloppiness sometimes occurs at this point. If the fit is loose, replace the actuator rod (46). This can be easily done by removing gear plate mounting screw (55).

MANUAL OF 1951 MOST-OFTEN-NEEDED RADIO DIAGRAMS

MOTOROLA, INC. Circuit diagrams of Models 5R11AU, 5R12AU, 5R13AU, 5R14AU, 5R15AU, 5R16AU, all using Chassis HS-281, are shown on this page. Chassis HS-280, used in the same numbered models but with a suffix "A" (not "AU"), omits choke-capacitor E1 and connects one side of the line to chassis. Chassis HS-242 and HS-254, used in the same numbered models but without any suffix or with suffix "U" only, use 35W4 rectifier.

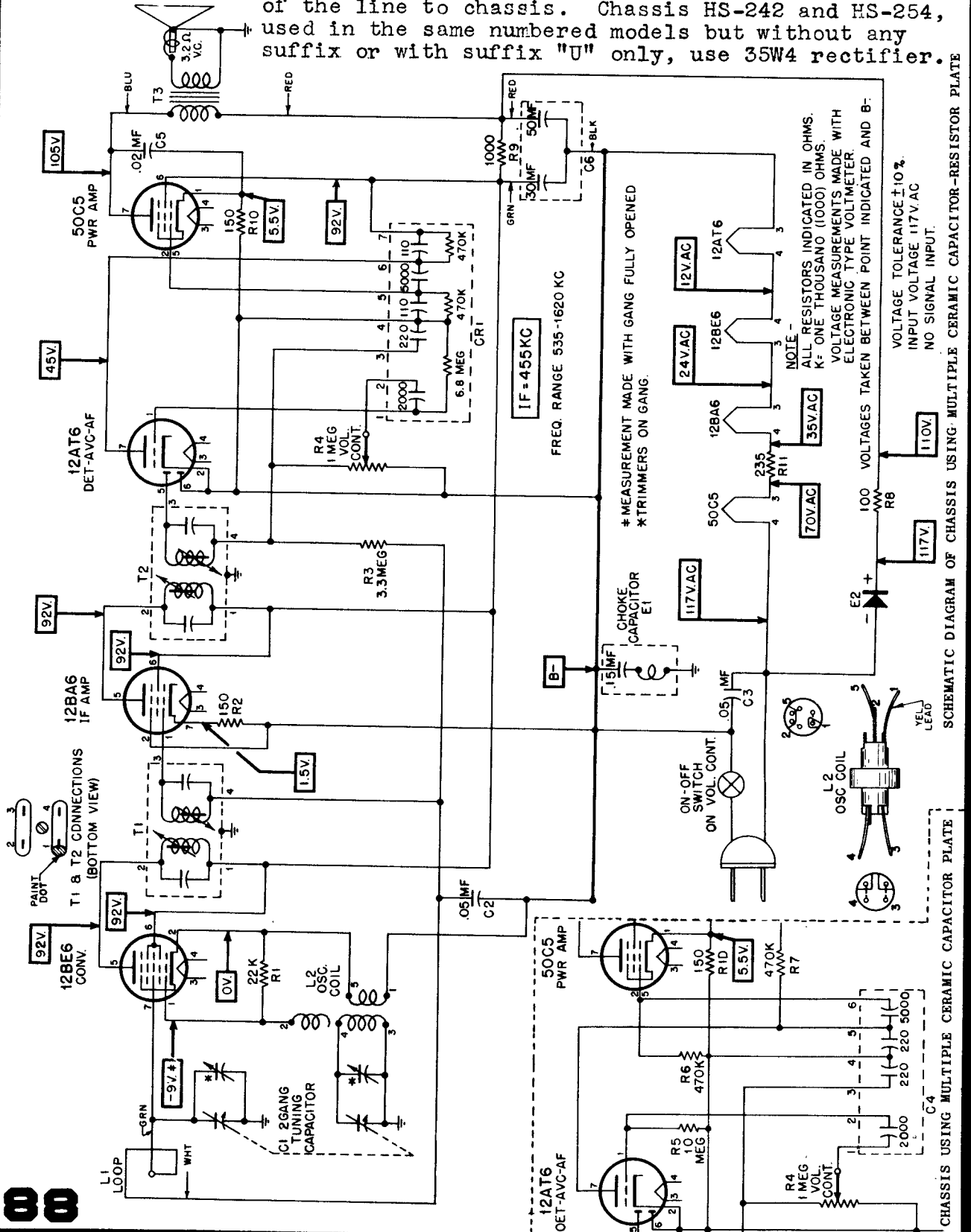

MANUAL OF 1951 MOST-OFTEN-NEEDED RADIO DIAGRAMS

MODELS
5X11U
5X12U
5X13U

Motorola Inc.
5H11U
5H12U
5H13U

5H11
5H12
5H13

CHASSIS
HS-243

CHASSIS
HS-244

CHASSIS
HS-256

Models 5H11, 5H12, 5H13,
 Chassis HS-256, omits
 C3, uses common chassis.

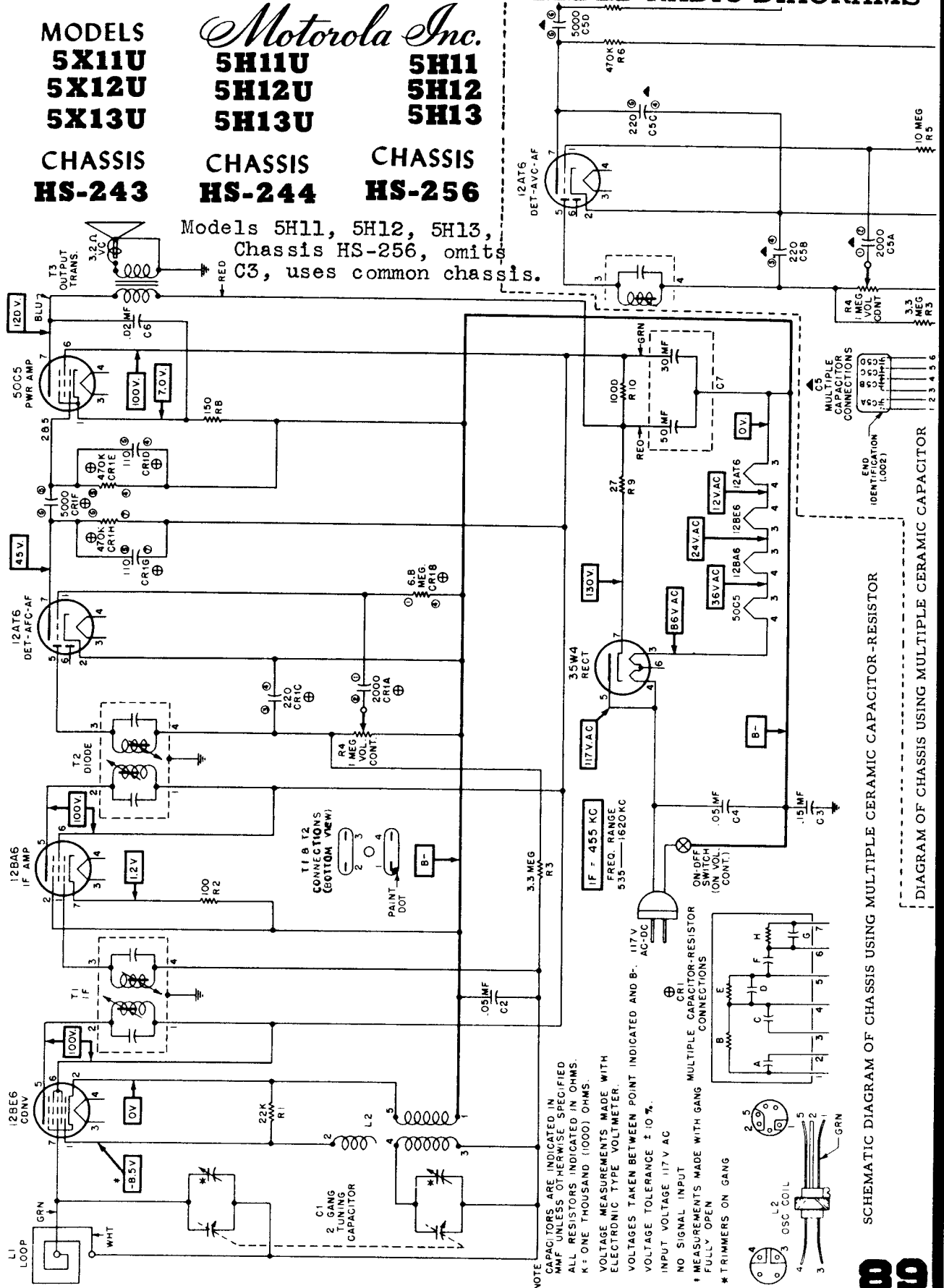

MANUAL OF 1951 MOST-OFTEN-NEEDED RADIO DIAGRAMS

Motorola Inc.

**MODELS
6X11U
6X12U**

**CHASSIS
HS-245**

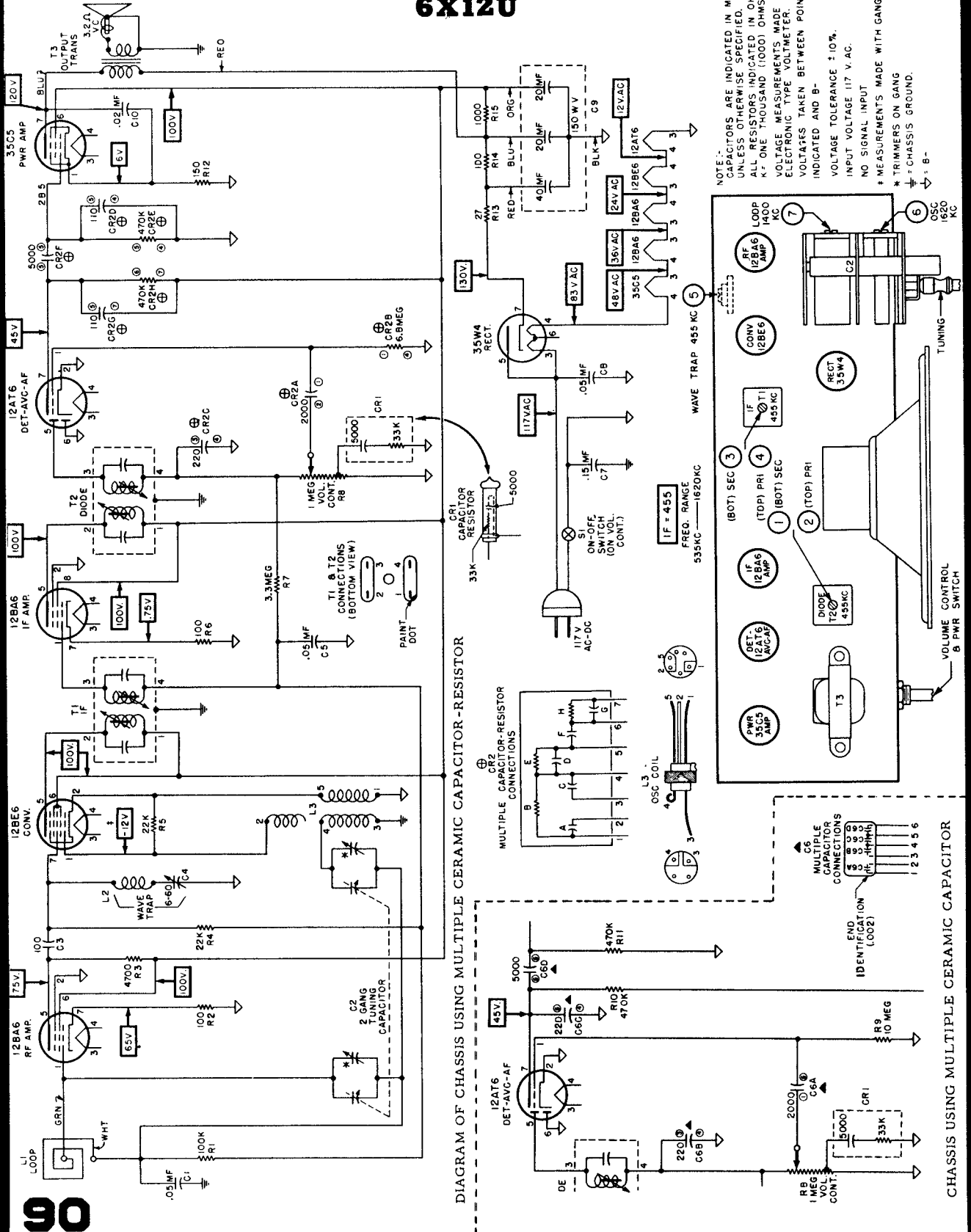

DIAGRAM OF CHASSIS USING MULTIPLE CERAMIC CAPACITOR-RESISTOR

CHASSIS USING MULTIPLE CERAMIC CAPACITOR

MANUAL OF 1951 MOST-OFTEN-NEEDED RADIO DIAGRAMS

Motorola HOME Radio

MODELS

5L1	5L1U
5L2	5L2U
51L1U	51L2U
5J1	5J1U
5J2	5J2U

The models listed at right with the suffix "U" use Chassis HS-224, the other models use Chassis HS-250. The circuit shown is exact for HS-250 using multiple capacitor-resistor plate. The insert diagram in the lower left hand corner shows differences in the HS-250 for a multiple capacitor plate. Chassis HS-224 uses both types of plates and differs from HS-250 in physical assembly and some circuit elements.

CHASSIS
HS-224
HS-250

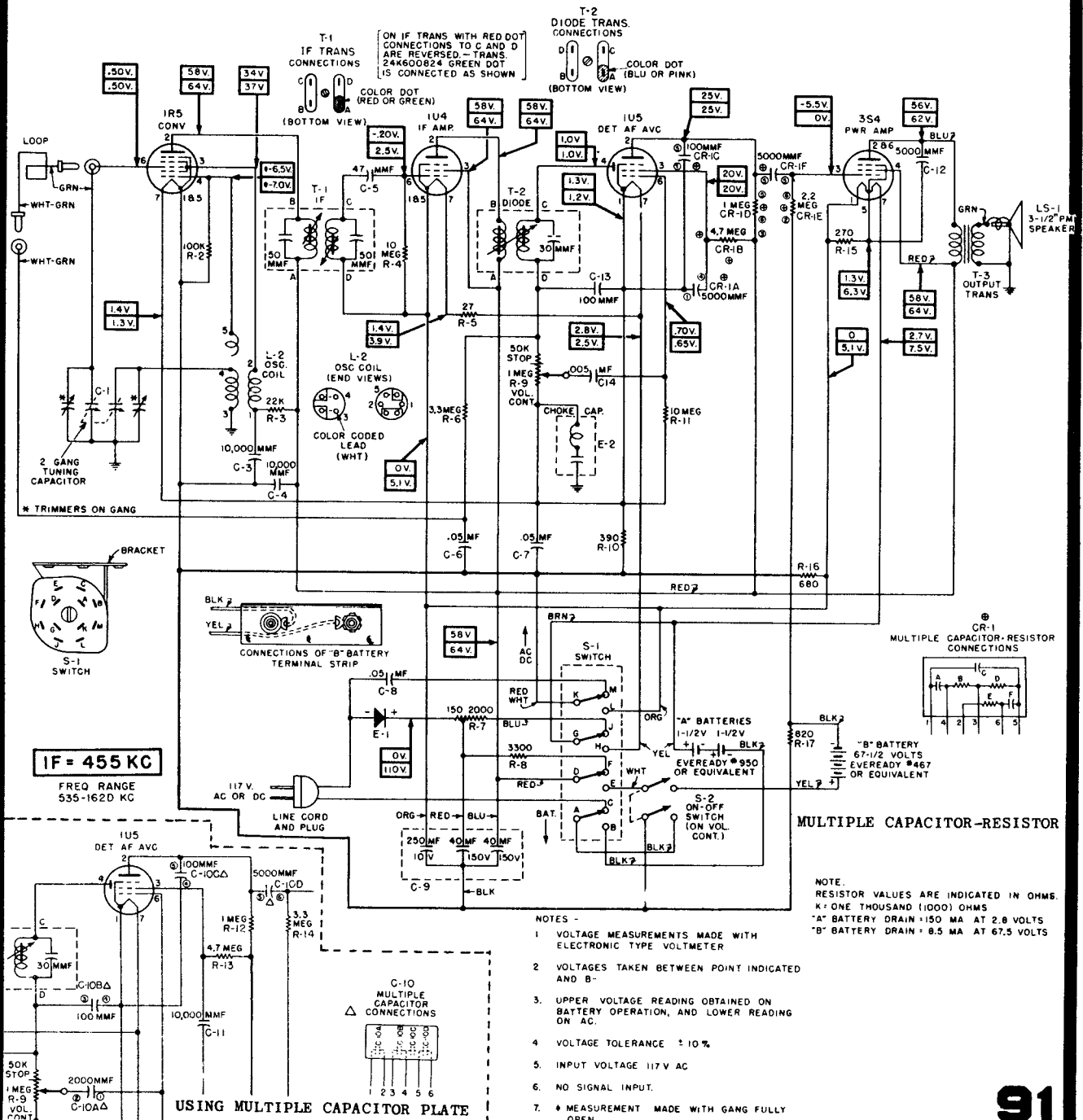

MANUAL OF 1951 MOST-OFTEN-NEEDED RADIO DIAGRAMS

Motorola Inc.

CHASSIS MODELS
HS-226 **6L1**
 6L2
 61L1
 61L2

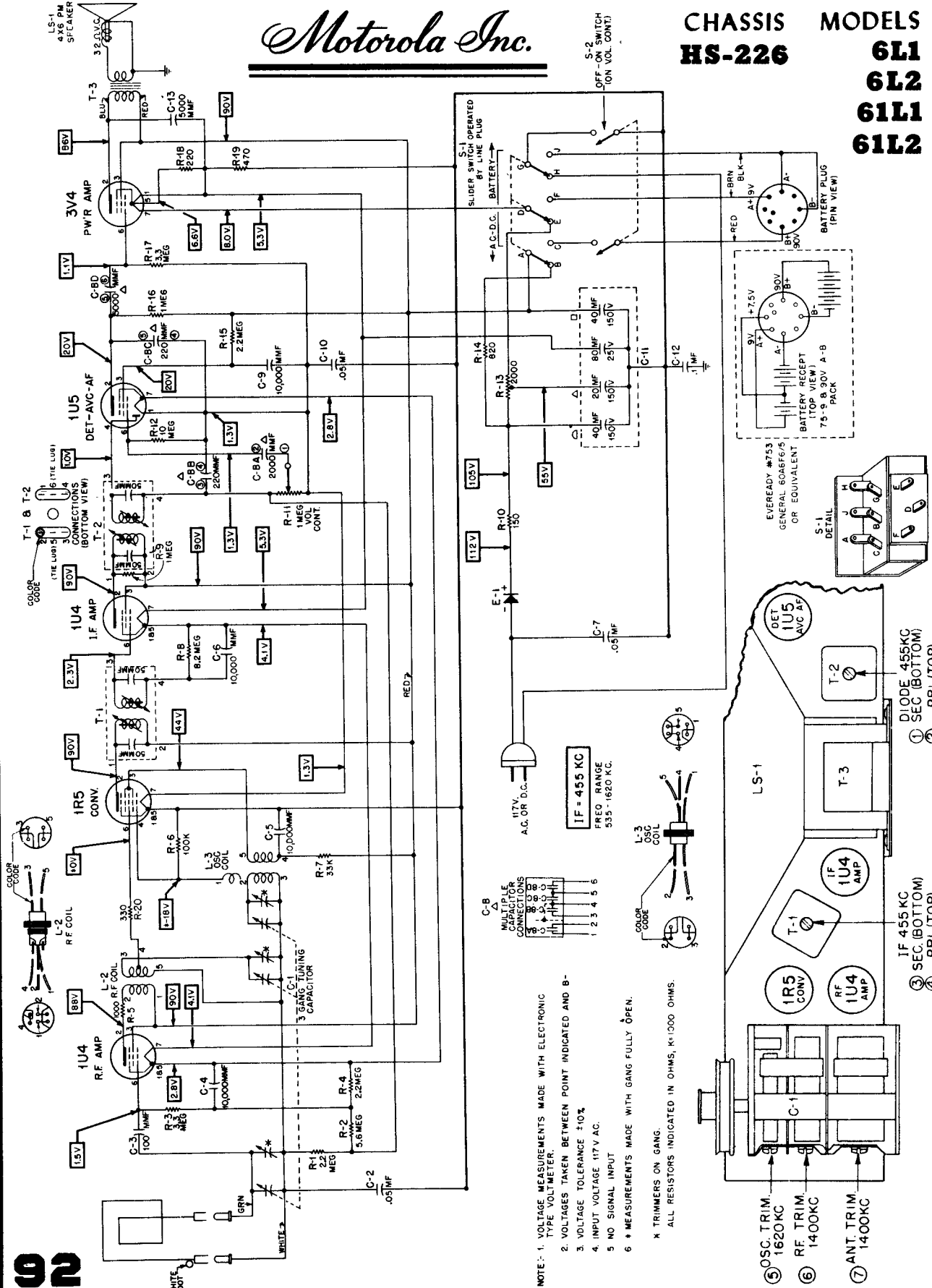

NOTE: 1. VOLTAGE MEASUREMENTS MADE WITH ELECTRONIC TYPE VOLTMETER.
 2. VOLTAGES TAKEN BETWEEN POINT INDICATED AND B-
 3. VOLTAGE TOLERANCE $\pm 10\%$.
 4. INPUT VOLTAGE 117 V AC.
 5. NO SIGNAL INPUT
 6 * MEASUREMENTS MADE WITH GANG FULLY OPEN.

X TRIMMERS ON GANG.
 ALL RESISTORS INDICATED IN OHMS, K:1,000 OHMS.

- ⑤ OSC. TRIM 1620KC
- ⑥ RF. TRIM. 1400KC
- ⑦ ANT. TRIM. 1400KC
- ① DIODE 455KC
- ② SEC. (BOTTOM)
- ③ PRI. (TOP)
- ④ SEC. (TOP)
- ⑤ PRI. (BOTTOM)

MANUAL OF 1951 MOST-OFTEN-NEEDED RADIO DIAGRAMS

Motorola Inc.

**MODELS
51M1U
51M2U
CHASSIS
HS-283**

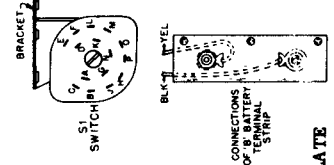
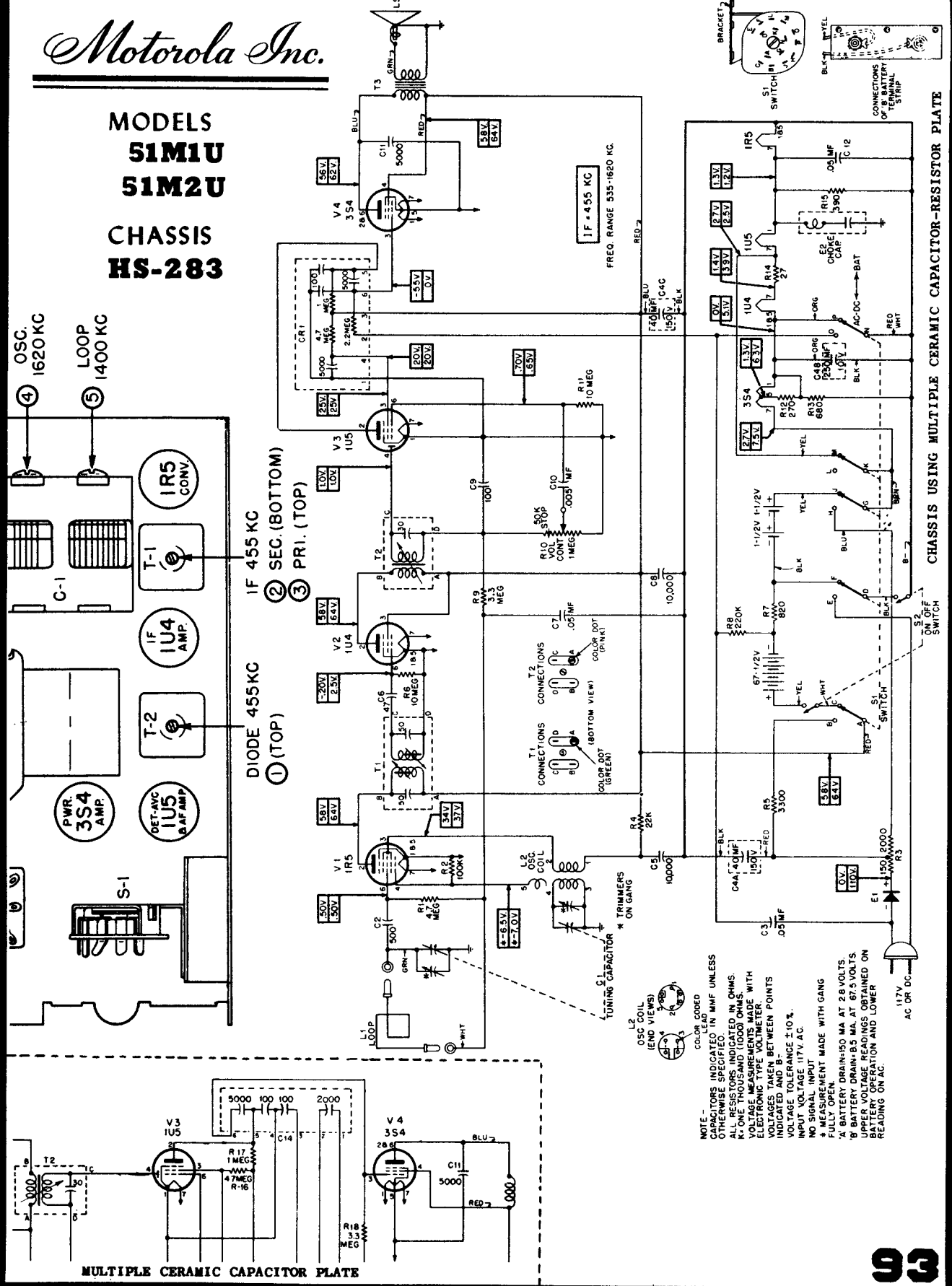

CHASSIS USING MULTIPLE CERAMIC CAPACITOR-RESISTOR PLATE

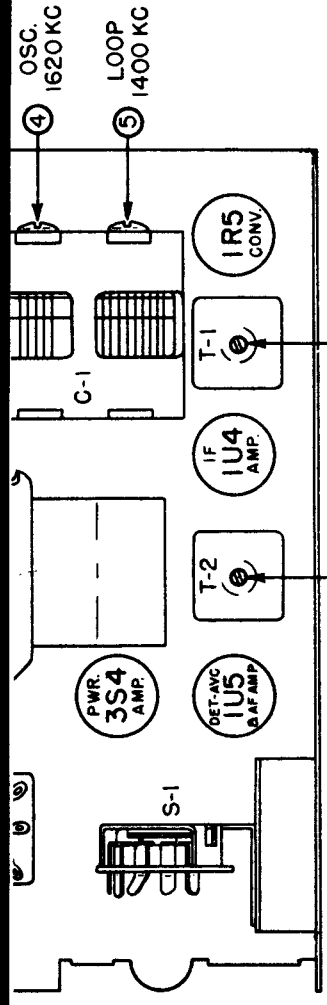

① (TOP)
 ② SEC. (BOTTOM)
 ③ PRI. (TOP)

MULTIPLE CERAMIC CAPACITOR PLATE

NOTE -
 CAPACITORS INDICATED IN MMF UNLESS OTHERWISE SPECIFIED. IN OHMS, K = ONE THOUSAND, L = ONE HUNDRED THOUSAND, M = ONE MILLION.
 VOLTAGE MEASUREMENTS MADE WITH ELECTRONIC TYPE VOLTMETER.
 VOLTAGES TAKEN BETWEEN POINTS INDICATED AND B-
 VOLTAGE TOLERANCE ±10%.
 * TRIMMERS ON GANG
 ** SIGNAL INPUT
 † MEASUREMENT MADE WITH GANG FULLY OPEN.
 ‡ BATTERY DRAIN-150 MA AT 28 VOLTS.
 § UPPER VOLTAGE READINGS OBTAINED ON BATTERY OPERATION AND LOWER READINGS ON AC.

MANUAL OF 1951 MOST-OFTEN-NEEDED RADIO DIAGRAMS

MODELS
8FM21
8FM21B
CHASSIS
HS-247

Motorola HOME Radio

TUNING RANGE - AM 535 to 1620 Kc AM IF - 455 Kc
 FM 88 to 108 Mc FM IF - 10.7 Mc

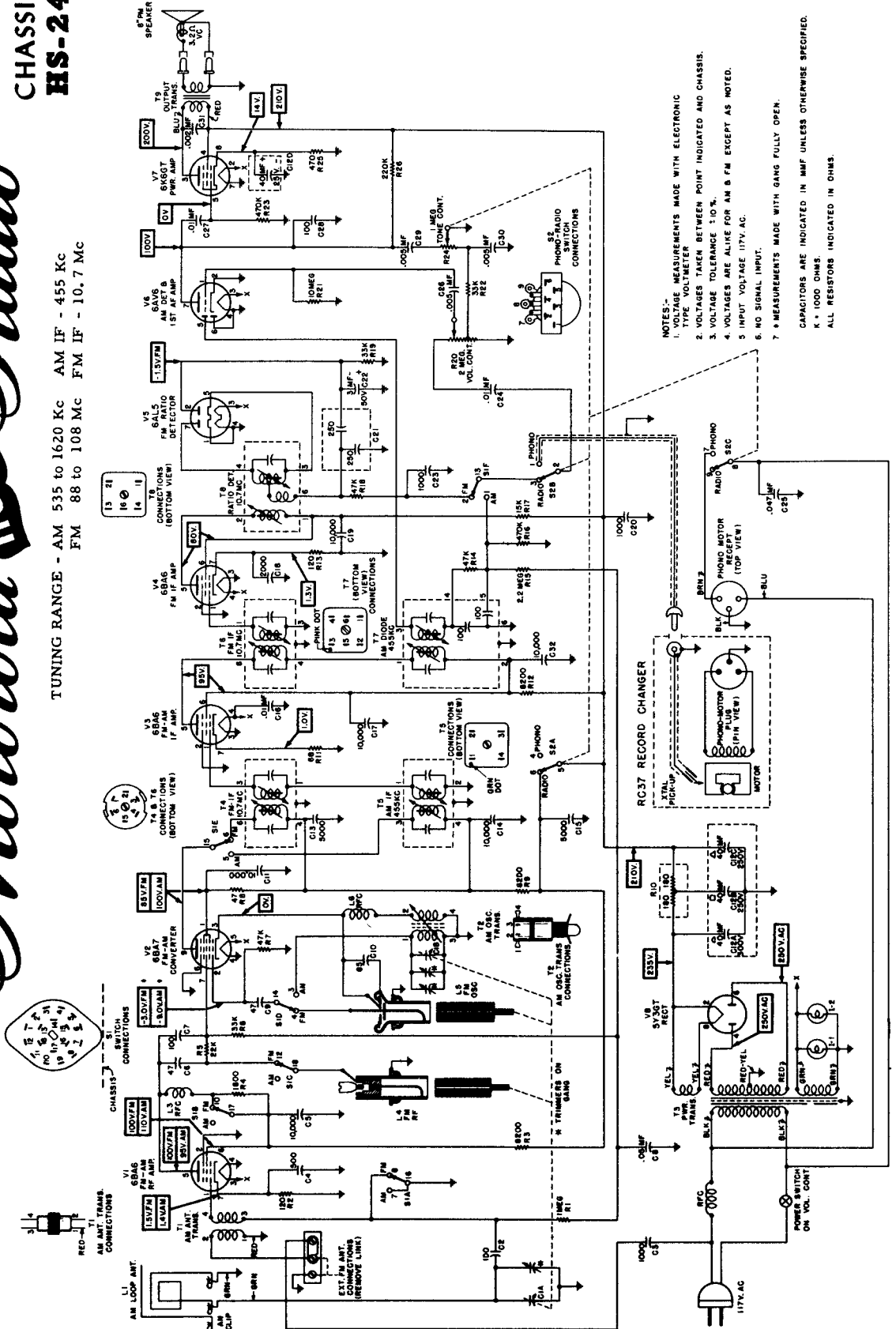

- NOTES:-**
1. VOLTAGE MEASUREMENTS MADE WITH ELECTRONIC TYPE VOLTMETER
 2. VOLTAGES TAKEN BETWEEN POINT INDICATED AND CHASSIS.
 3. VOLTAGE TOLERANCE 5.0%.
 4. VOLTAGES ARE ALIKE FOR AM & FM EXCEPT AS NOTED.
 5. INPUT VOLTAGE 117V. AC.
 6. NO SIGNAL INPUT.
 7. * MEASUREMENTS MADE WITH GANG FULLY OPEN.

CAPACITORS ARE INDICATED IN MMF UNLESS OTHERWISE SPECIFIED.
 K = 1000 OHMS.
 ALL RESISTORS INDICATED IN OHMS.

PRINTED CIRCUIT "PENTODE COUPLATE"
CENTRAL LAB. YA 408-002A.

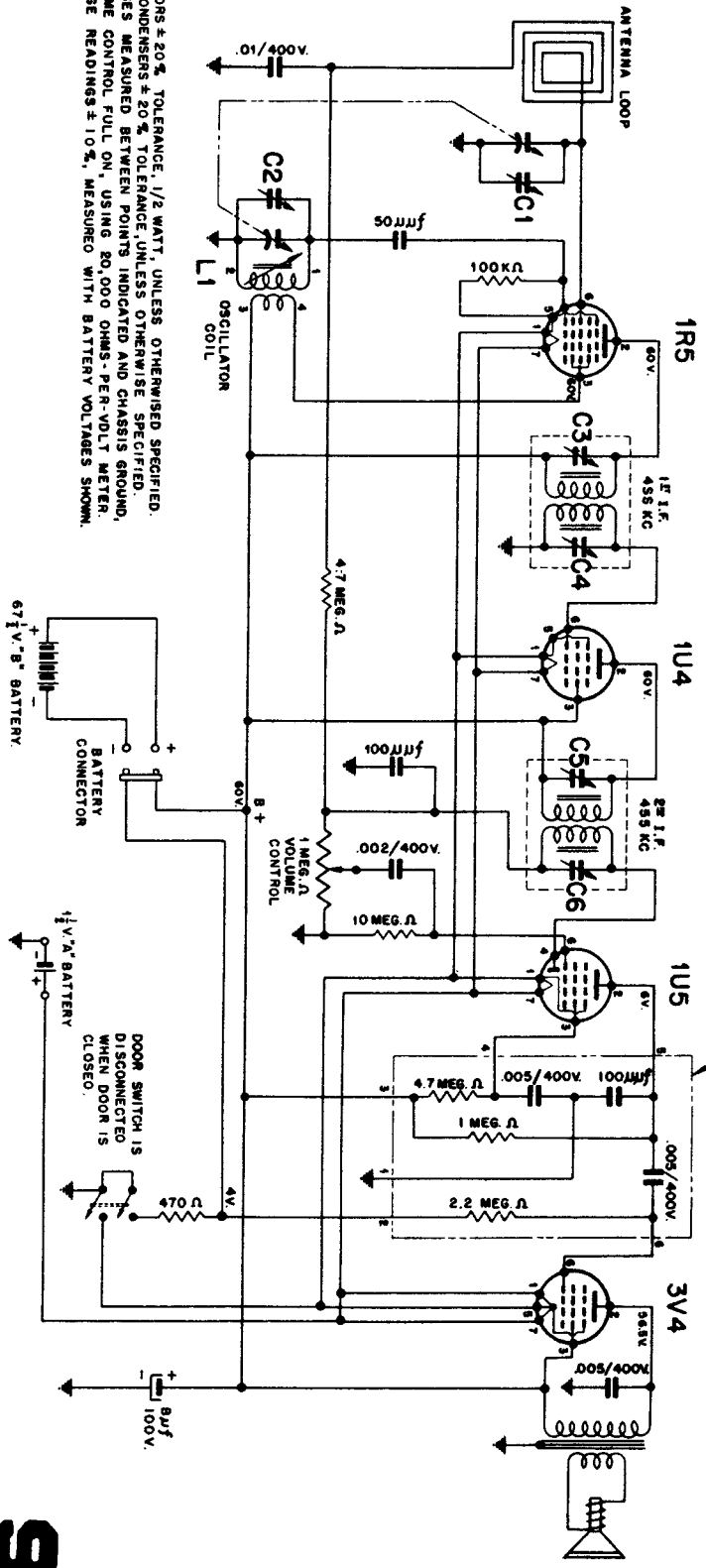

- NOTES:
- 1 ALL RESISTORS ± 20% TOLERANCE, 1/2 WATT, UNLESS OTHERWISE SPECIFIED.
 - 2 ALL MICA CONDENSERS ± 20% TOLERANCE, UNLESS OTHERWISE SPECIFIED.
 - 3 ALL VOLTAGES MEASURED BETWEEN POINTS INDICATED AND CHASSIS GROUND, WITH VOLUME CONTROL FULL ON, USING 20,000 OHMS-PER-VOLT METER.
- ALL VOLTAGE READINGS ± 10%, MEASURED WITH BATTERY VOLTAGES SHOWN.

MANUAL OF 1951 MOST-OFTEN-NEEDED RADIO DIAGRAMS

OLYMPIC RADIO & TELEVISION INC.

MODEL 489

TUBE AND BATTERY LAYOUT

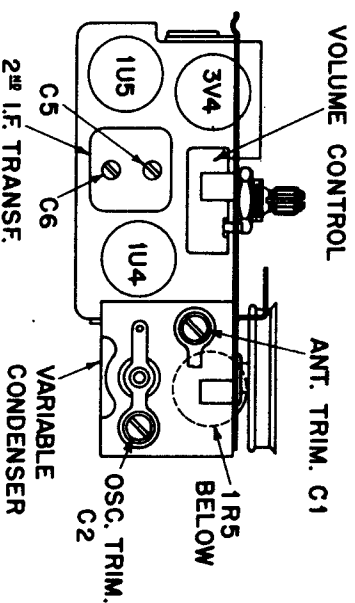
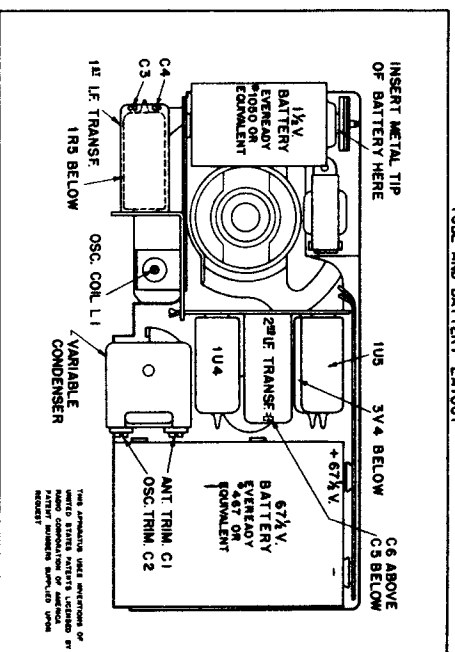

For alignment, the following equipment is required: A.M. modulated R.F. signal generator, VTVM or output meter, insulated screw driver, radiation loop (one turn of about 6" or 8" of #12 or #14 wire connected across the output of the signal generator and placed parallel to receiver loop about 8" away), one 0.1 mfd. 400 v. condenser. Before aligning, close the variable condenser fully counterclockwise (plates fully closed) and check pointer position. Follow sequence in alignment procedure chart below.

ALIGNMENT PROCEDURE CHART

STEP	CONNECT HIGH SIDE OF SIGNAL GENERATOR TO-	SET SIGNAL GENERATOR TO-	SET POINTER TO-	ADJUST THE FOLLOWING FOR MAXIMUM OUTPUT. (KEEP SIGNAL FROM SIGNAL GENERATOR AS LOW AS POSSIBLE.)
1	R. F. SECTION OF VARIABLE CONDENSER IN SERIES WITH A 1.MFD. 400VOLT CONDENSER.	455 KC.	EXTREME RIGHT HAND POSITION (CONDENSER PLATES FULLY OPEN)	C6, C5, C4, C3 AND REPEAT IN SAME ORDER (1st AND 2nd. I.F. TRANSFORMERS)
2	USE RADIATED SIGNAL.	1600 KC.	1600 KC. (160 ON DIAL)	C2 (OSCILLATOR TRIMMER)
3	CONNECT BOTH SIDES OF SIGNAL GENERATOR TO RADIATION LOOP)	1400 KC.	MAXIMUM SIGNAL (APPROX. 140 ON DIAL)	C1 (ANTENNA TRIMMER)
4	TO RADIATION LOOP)	600 KC.	MAXIMUM SIGNAL (APPROX 60 ON DIAL)	ADJUST L1 ROCK VARIABLE FOR MAXIMUM SIGNAL.
5	REPEAT STEPS 2, 3 & 4 AT LEAST TWICE TO INSURE MAXIMUM SENSITIVITY & PROPER DIAL TRACKING.			

MANUAL OF 1951 MOST-OFTEN-NEEDED RADIO DIAGRAMS

PHILCO RADIO MODELS 51-530, 51-532 and 51-534

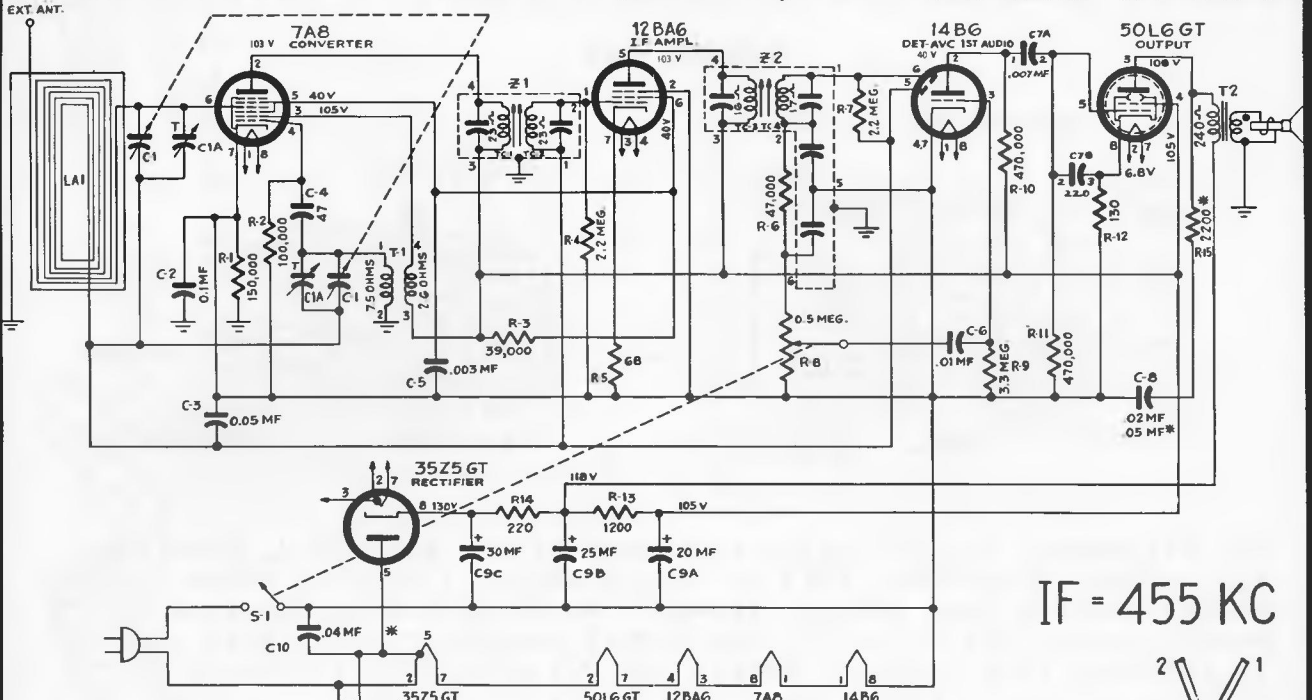

IF = 455 KC

* THE FOLLOWING APPLIES ONLY TO MODEL 51-530:
R-15 (NOT USED IN MODELS 51-532 & 51-534)
C-8 IS A .05 μf CONDENSER
RECTIFIER IS WIRED AS SHOWN IN INSERT.

ALL VOLTAGES MEASURED WITH 20,000 OHMS PER-VOLT METER BETWEEN POINTS INDICATED AND B MINUS AT A LINE VOLTAGE OF 117V AC.

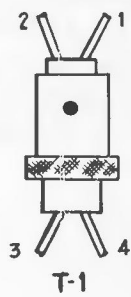
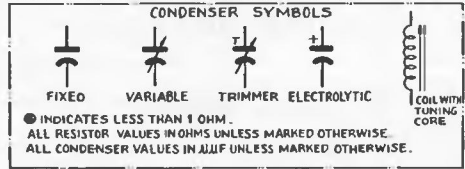

Symbolized Chassis, Showing Parts Placement

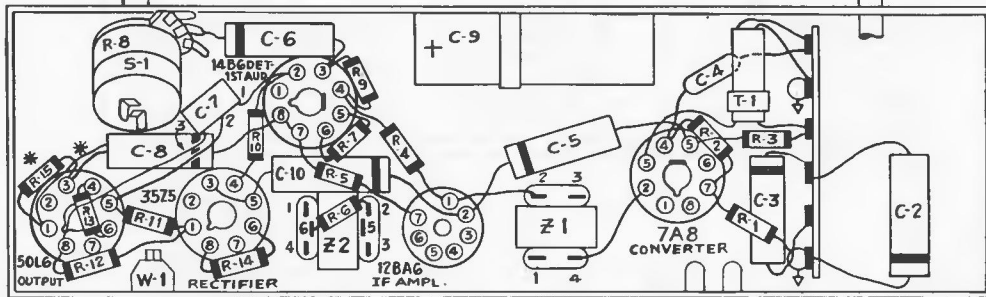

* THIS PART AND WIRING CHANGE REFER TO MODEL 51-530 ONLY.

- TC4—2nd i-f sec.
- TC3—2nd i-f pri.
- TC2—1st i-f sec.
- TC1—1st i-f pri.
- C1B—osc.
- C1A—aerial



NOTE: TC1 and TC3 are located on underside of chassis.

Top View, Showing Trimmer Locations

External Antenna Connection

MANUAL OF 1951 MOST-OFTEN-NEEDED RADIO DIAGRAMS

PHILCO RADIO-CLOCK, MODELS 51-537 and 51-537-I

Model 51-538 is identical in circuit to 51-537 here described. In some Model 51-538 sets (Code 122) a 12BA6 is used instead of 14A7. The Philco material in this manual is reprinted through the courtesy of Philco Corp.

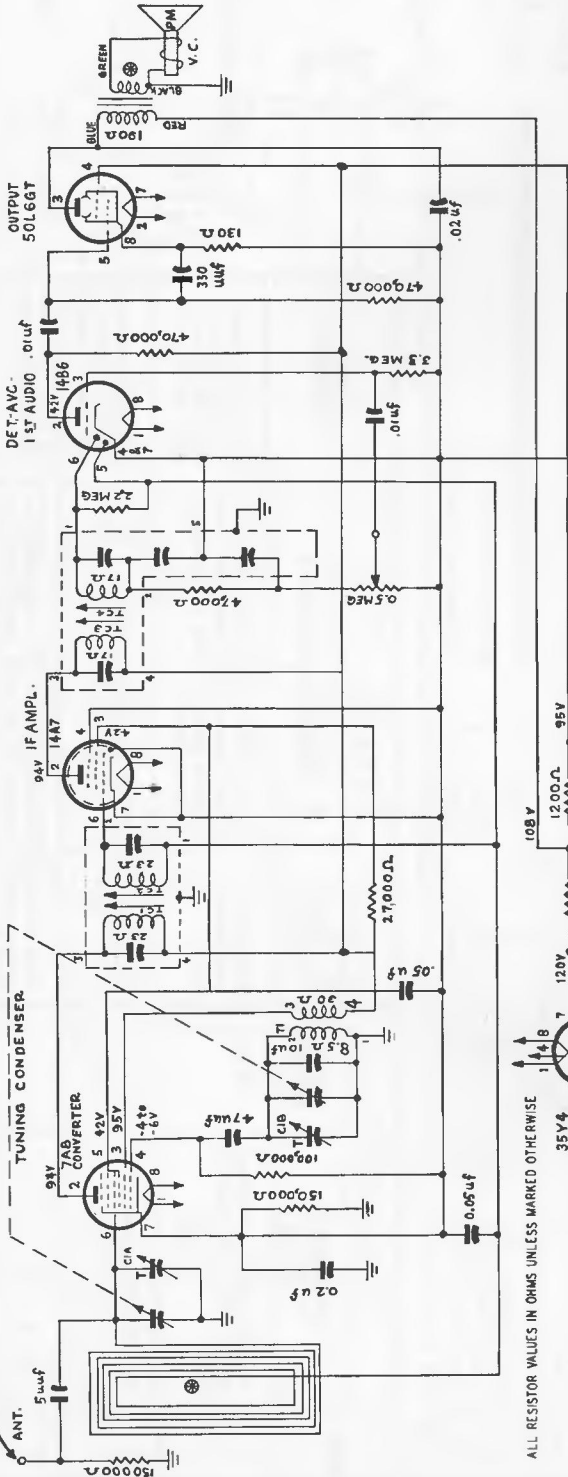

Top View, Showing Trimmer Location

TC1 and TC3 are located on underside of chassis.

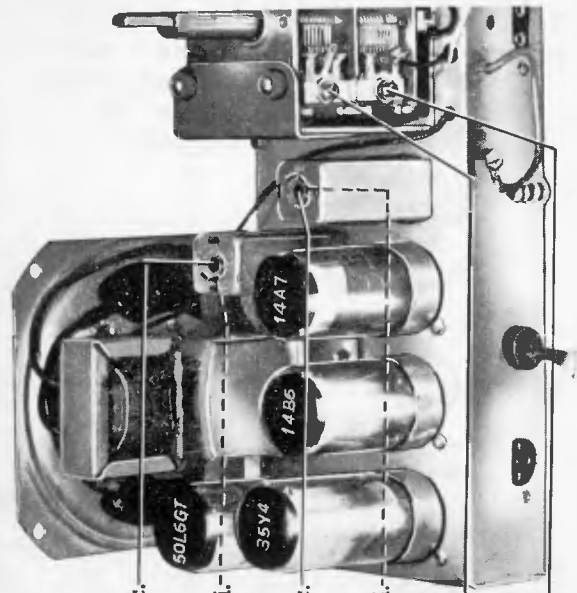

TC4—2nd if sec.
TC3—2nd if pri.
TC2—1st if sec.
TC1—1st if pri.
C1B—Osc.
C1A—Aerial

ALL RESISTOR VALUES IN OHMS UNLESS MARKED OTHERWISE

IF=455KC

NOTE: VOLTAGES SHOWN WERE MEASURED WITH
INDICATED POINTS
INDICATED TO 5 MINUS AT A LINE VOLTAGE
OF 117V AC

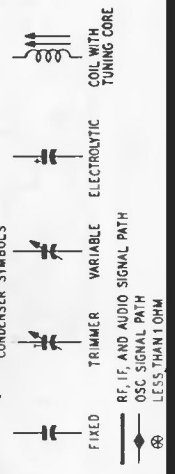
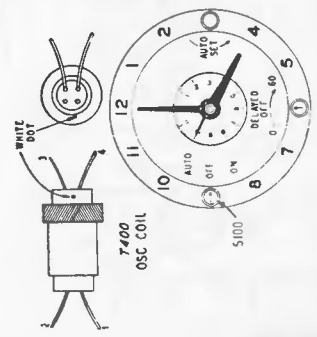

MANUAL OF 1951 MOST-OFTEN-NEEDED RADIO DIAGRAMS

PHILCO AUTO RADIO MODEL CR-501

Models CR-503 and CR-505 have external speakers, and CR-505 uses push-buttons, but their circuits are similar to Model CR-501.

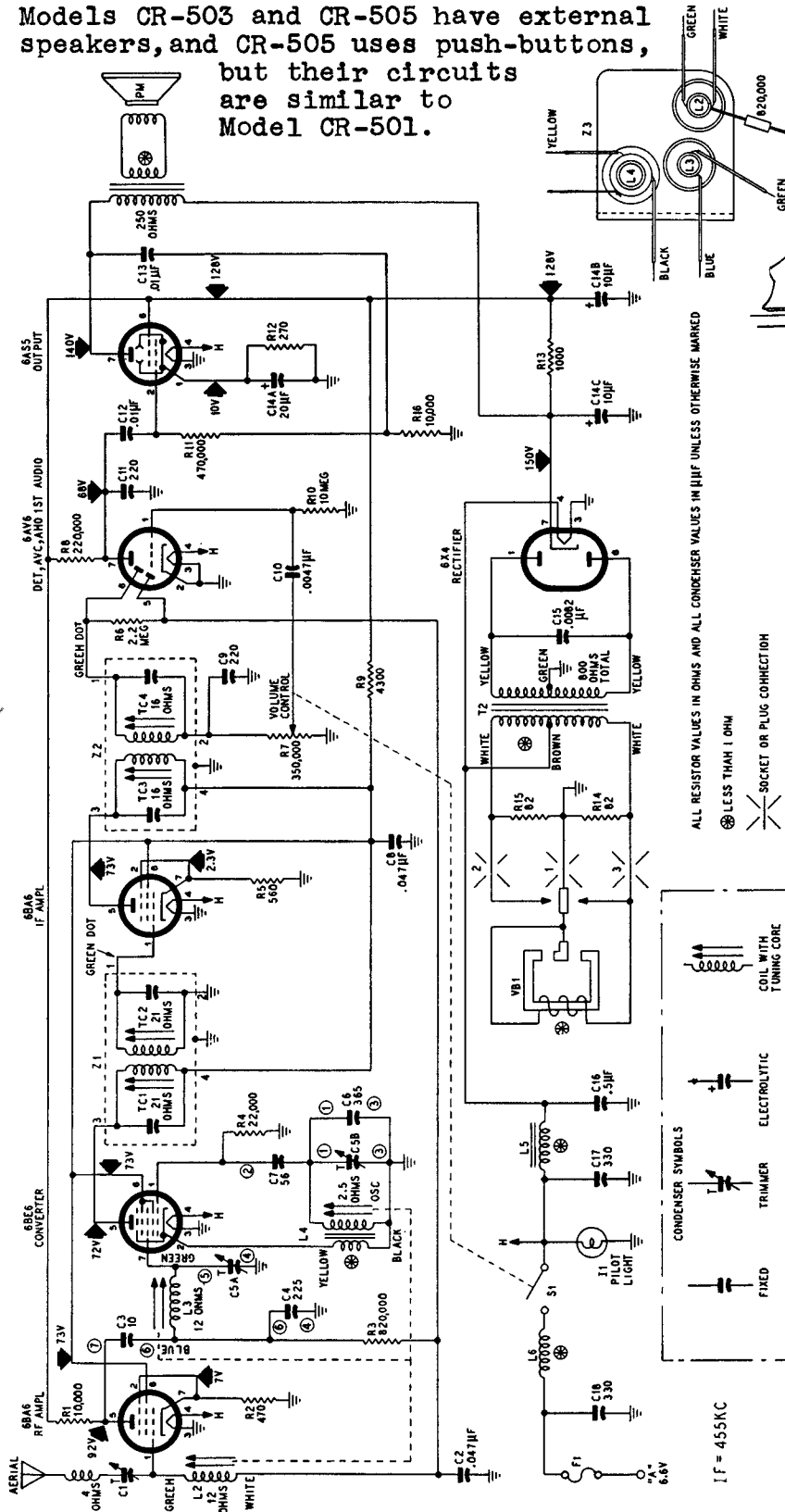

STEP	SIGNAL GENERATOR		RADIO	
	CONNECTION TO RADIO	DIAL SETTING	DIAL SETTING	SPECIAL INSTRUCTIONS
1	Through .05- μ f. condenser to converter grid (pin 7 of 6BE6).	455 kc.	Maximum counterclockwise	Adjust cores, in order given, for maximum output. TC1 and TC3 are reached through holes in bottom of i.f. transformers.
2	Through dummy aerial.	1605 kc.	1605 kc.	Adjust for maximum output.
3			Tune to weak station near 1600 kc.	Readjust trimmer C1, with radio in station near 1600 kc.

Trimmer Locations

MANUAL OF 1951 MOST-OFTEN-NEEDED RADIO DIAGRAMS

PHILCO RADIO-PHONOGRAPH MODEL 51-1330

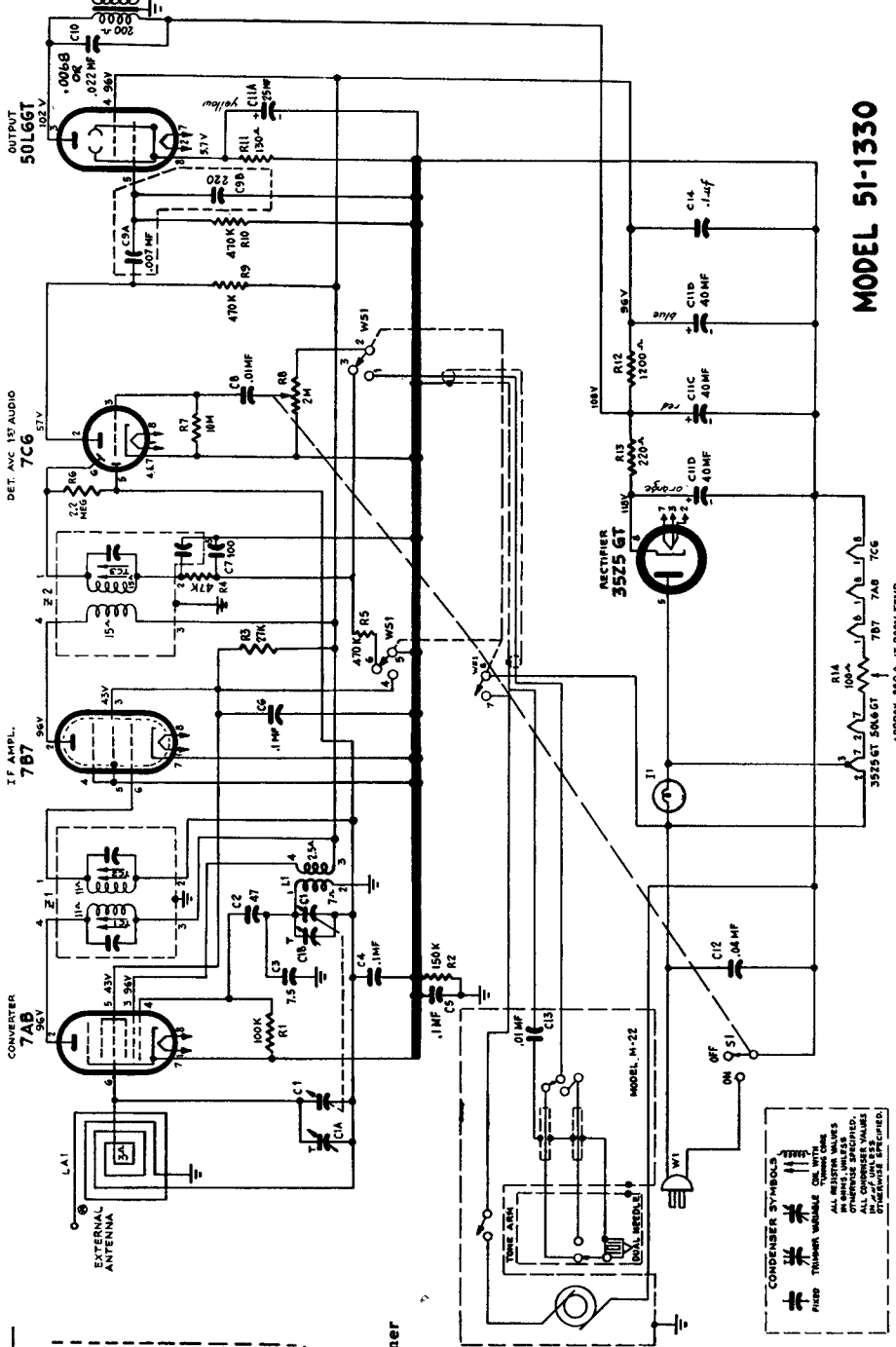

**MODEL 51-1330
IF 455 KC**

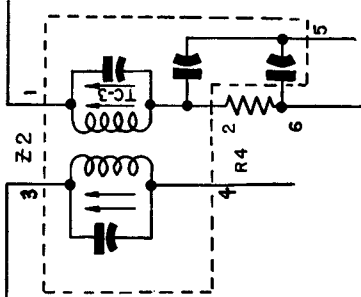
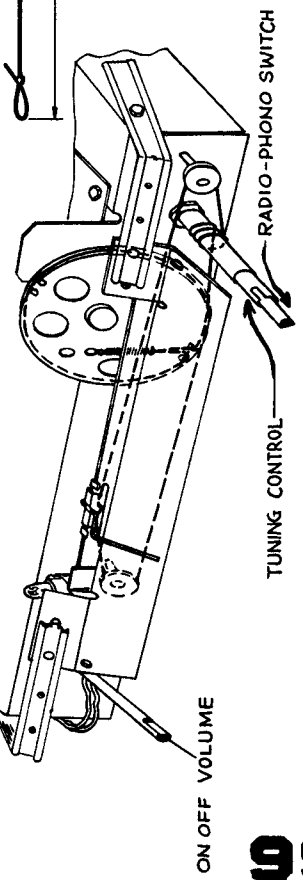
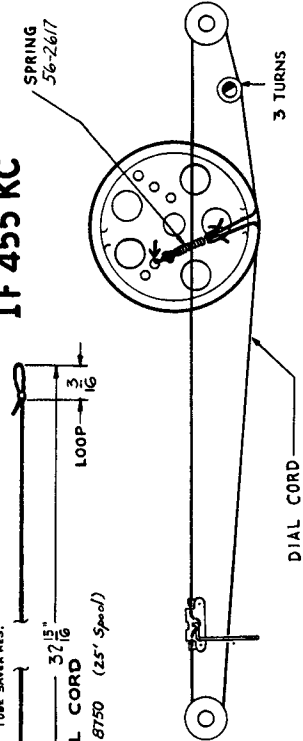

Run 2 i-f Transformer
The 2nd i-f transformer, 32-4240. This transformer is double tuned and has two 100 μ f. i-f filter condensers built-in.

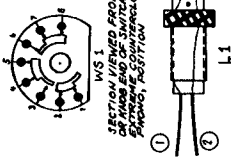

CONDENSER SYMBOLS
FIXED TRIMMER VARIABLE
ALL RESISTOR VALUES IN OHMS UNLESS OTHERWISE SPECIFIED.
RESISTOR VALUES IN K. UNLESS OTHERWISE SPECIFIED.

Drive-Cord Installation Details

MANUAL OF 1951 MOST-OFTEN-NEEDED RADIO DIAGRAMS PHILCO RADIO MODELS 51-930, 51-931 AND 51-932

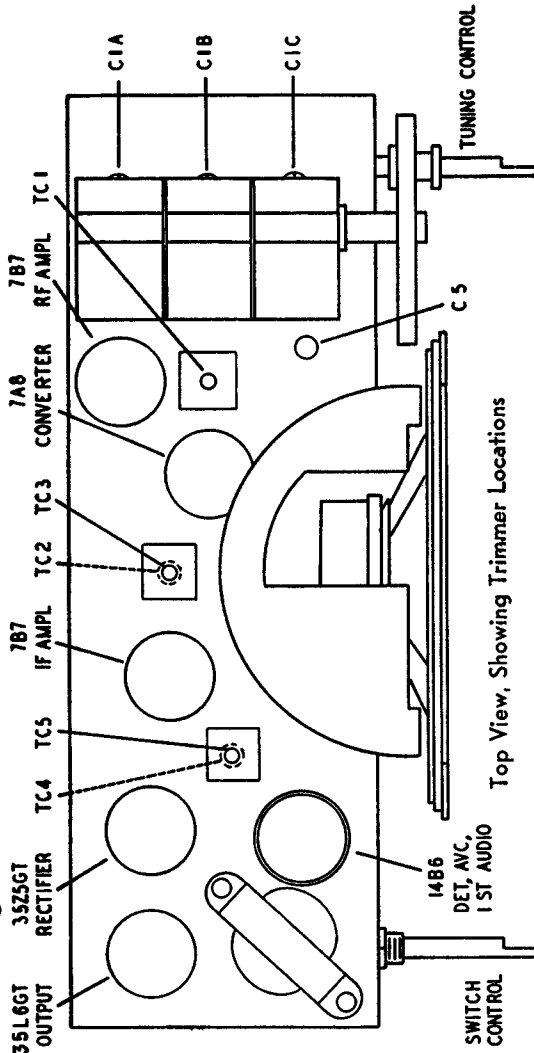
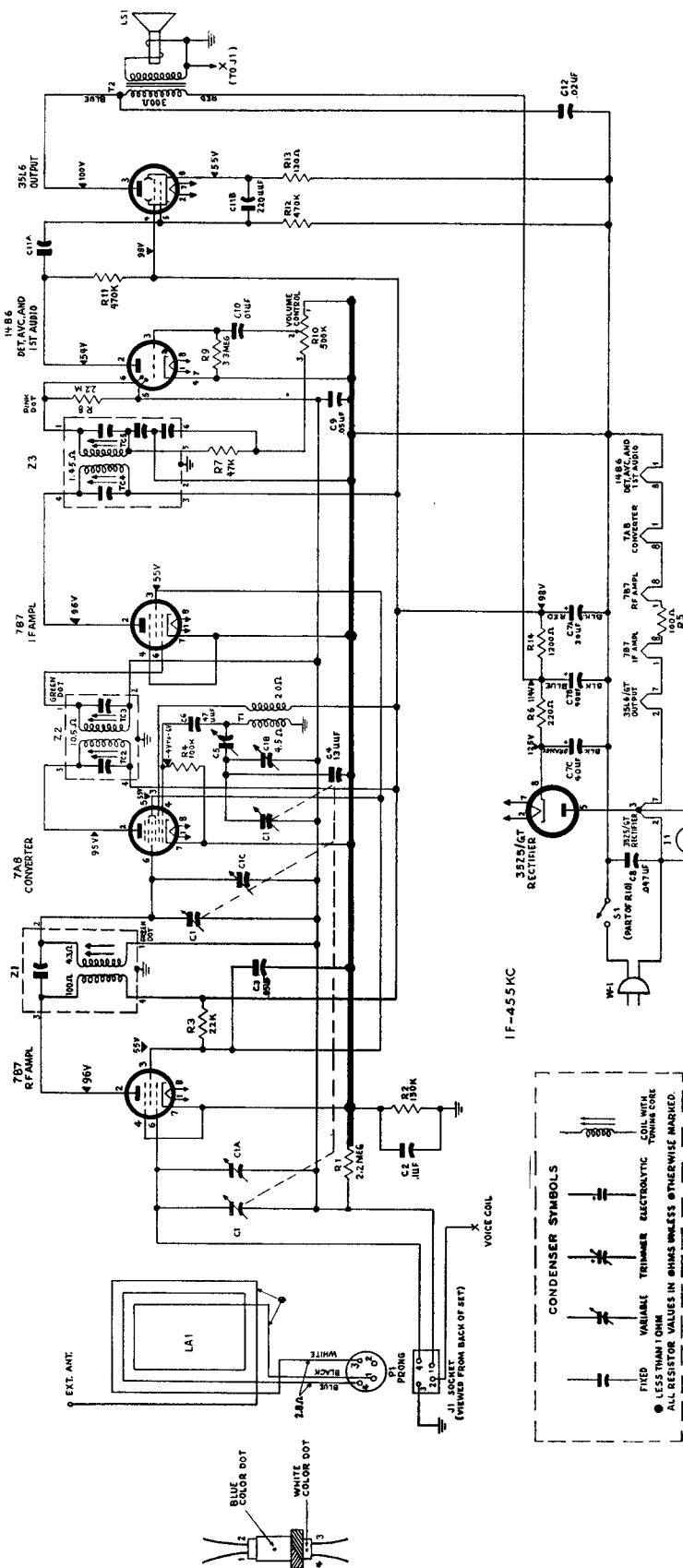

Top View, Showing Trimmer Locations

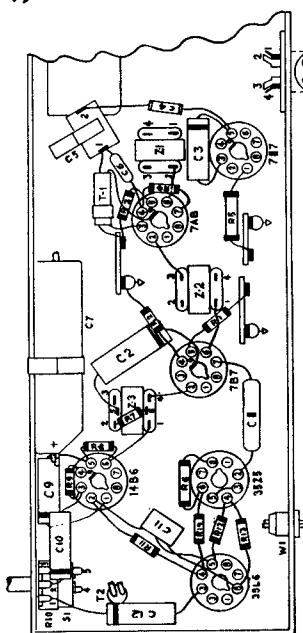

Symbolized Chassis, Showing Parts Placement

OSCILLATOR VOLTAGE MEASURED ACROSS R4 POSITIVE LEAD TO B; NEGATIVE LEAD TO PIN #4 WITH A 100,000 OHM RESISTOR IN SERIES, 20,000 OHM/VOLT, 10 VOLT RANGE. ALL OTHER VOLTAGES MEASURED WITH A 20,000 OHM-S PER-VOLT VOLTMETER BETWEEN POINTS INDICATED TO B-, AT A LINE VOLTAGE OF 117 V AC.

5A-1731-6W6
51-1732-6Y6G
OUTPUT

6V 8
DET AVC
AND 1ST AUDIO

6AU6
2ND IF
AMPL

6BA6
1ST IF
AMPL

* C44, C45 AND R39 ARE USED
IN MODEL 51-1732 ONLY.

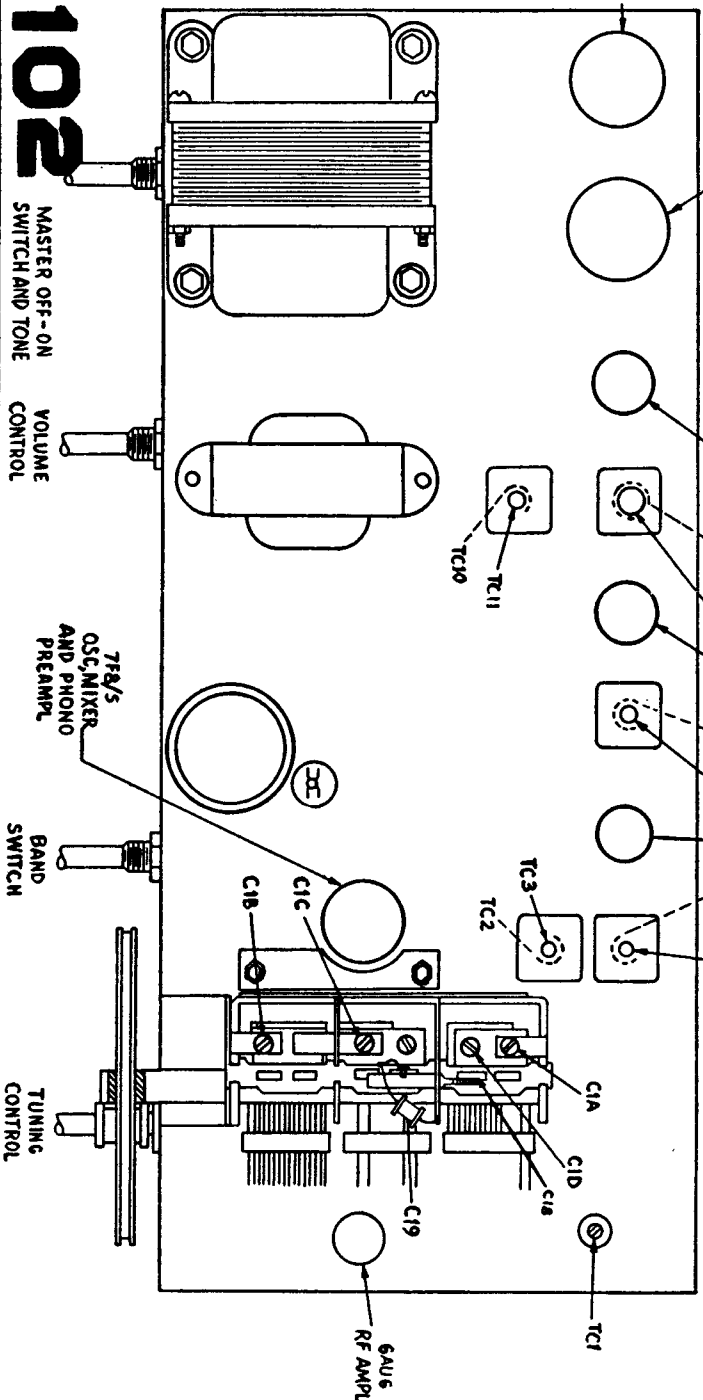

102
MASTER OFF-ON
SWITCH AND TONE

VOLUME
CONTROL

7F8/5
OSC, MIXER
AND PHONO
PREAMPL

BAND
SWITCH

TUNING
CONTROL

RADIO CHASSIS

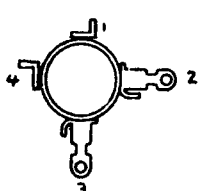
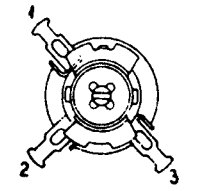
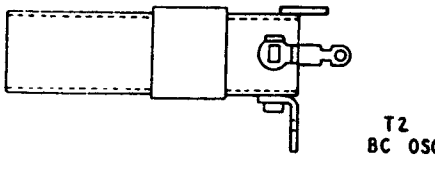
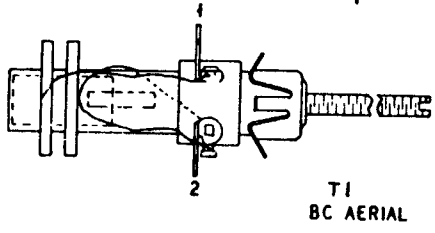

MANUAL OF 1951 MOST-OFTEN-NEEDED RADIO DIAGRAMS PHILCO RADIO-PHONOGRAPH MODELS 51-1731 and 51-1732

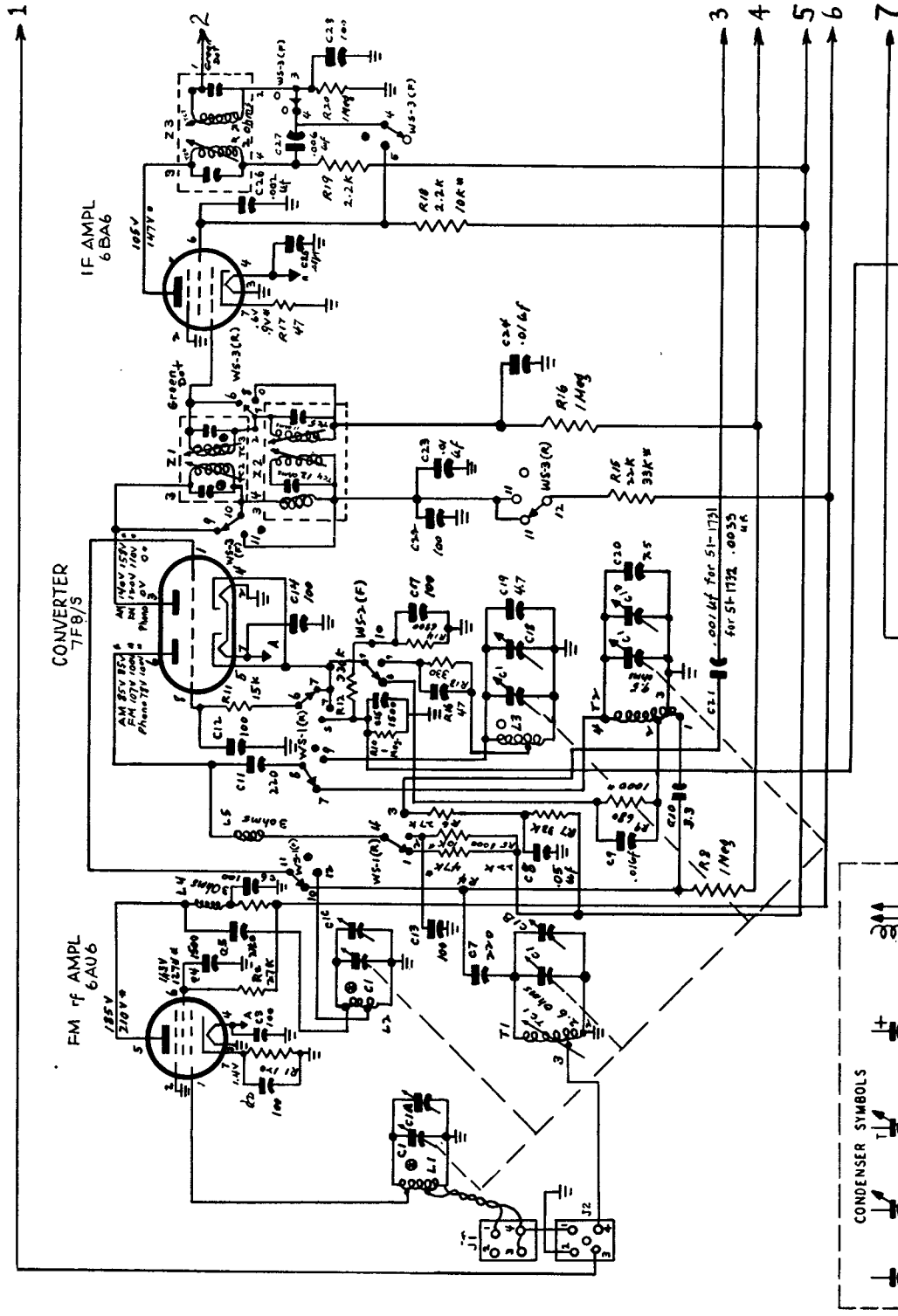

CONDENSER SYMBOLS

FIXED VARIABLE TRIMMER ELECTROLYTIC. COIL WITH TUNING CORE

ALL RESISTOR VALUES IN OHMS AND ALL CONDENSER VALUES IN μUF UNLESS MARKED OTHERWISE

VOLTAGES WERE MEASURED FROM POINTS INDICATED TO GROUND WITH A 20,000-OHMS-PER-VOLT METER AT A LINE VOLTAGE OF 117VAC

⊙ INDICATES LESS THAN 1 OHM

* THE PARTS VALUES AND VOLTAGES MARKED WITH AN ASTERISK APPLY TO MODEL 51-1732

Top View, Showing Trimmer Locations

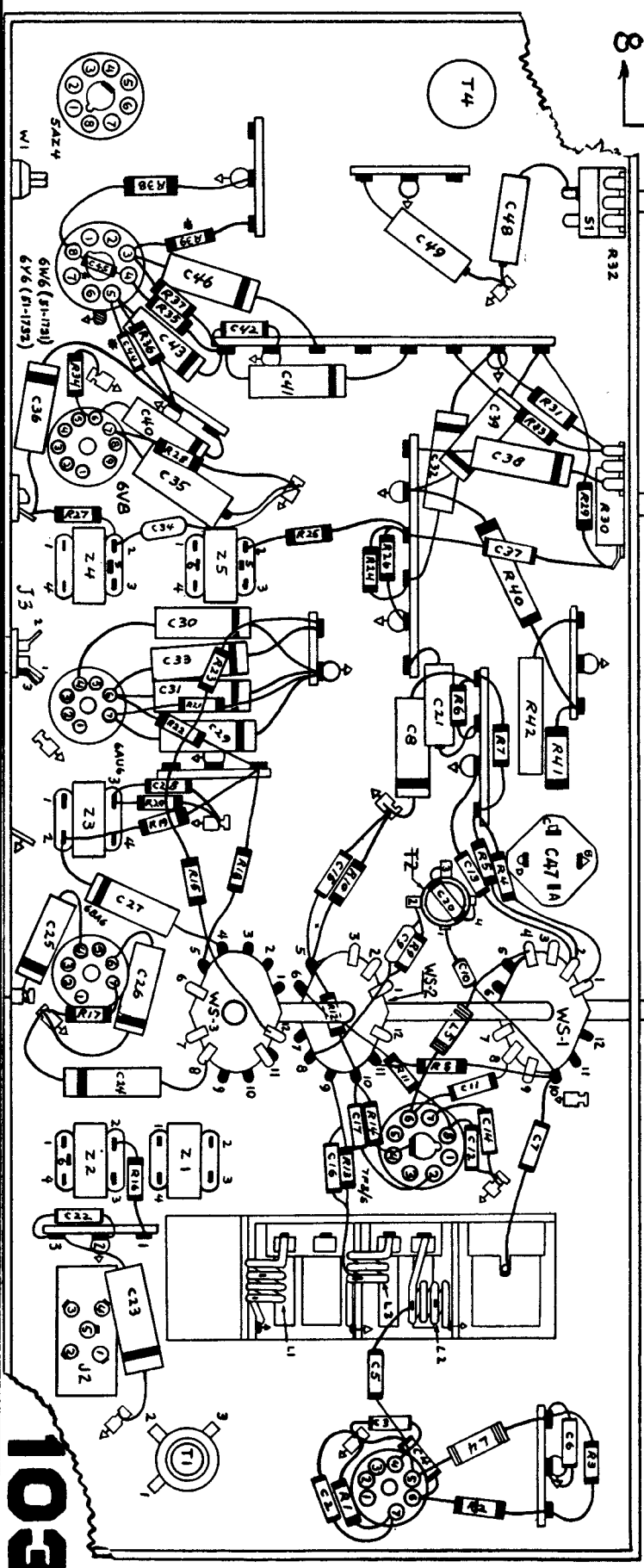

103

MANUAL OF 1951 MOST-OFTEN-NEEDED RADIO DIAGRAMS

Philco Radio-Phonograph Models 51-1731 and 51-1732, continued,
(Alignment Information on the next page).

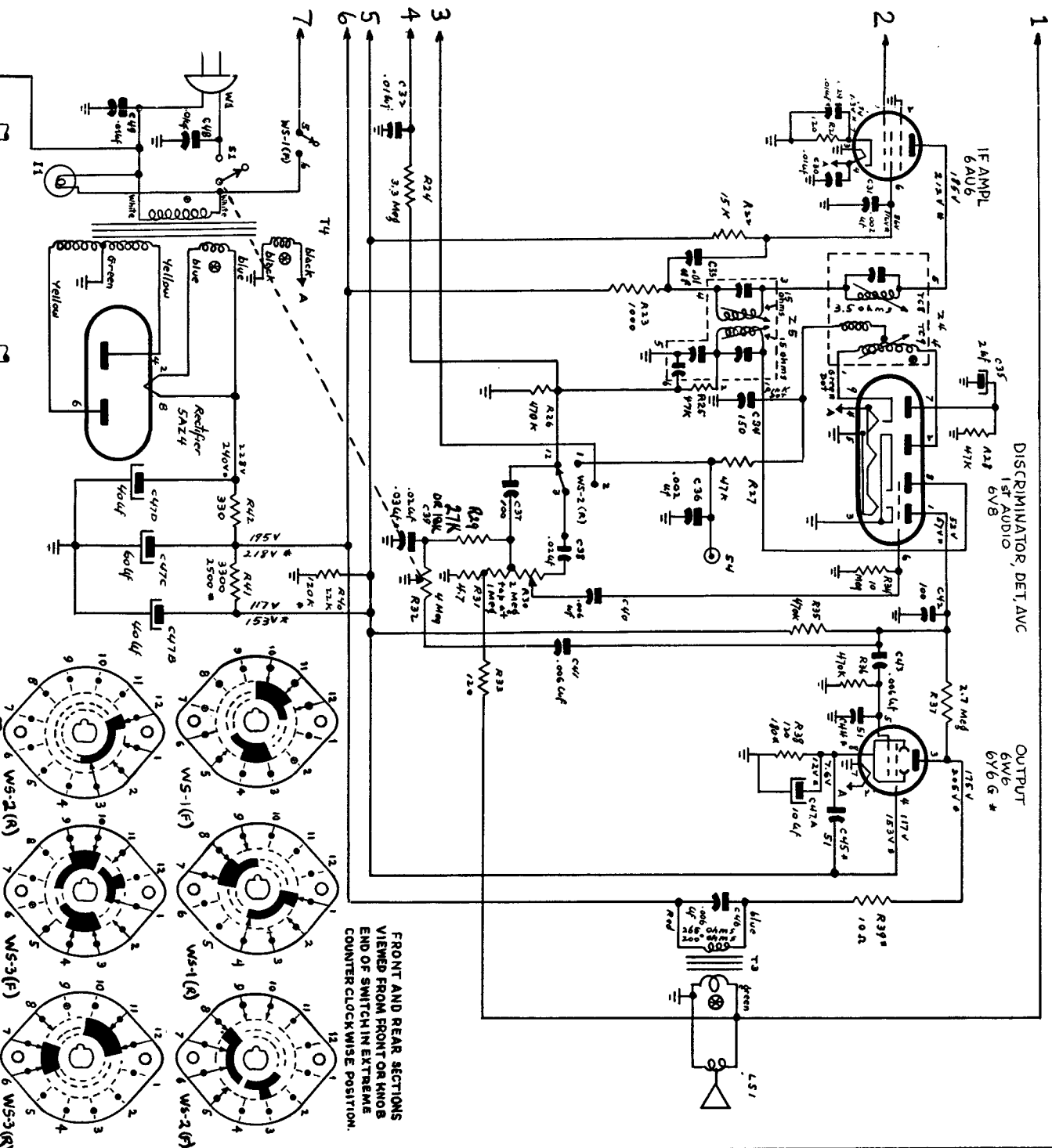

MANUAL OF 1951 MOST-OFTEN-NEEDED RADIO DIAGRAMS

Philco Models 51-1731 and 51-1732 Alignment Information (continued)

AM ALIGNMENT PROCEDURE

Make alignment with loop aerial connected to radio. The AM alignment should be made before the FM alignment.

DIAL POINTER: Calibration and pointer-index measurements are shown in figure 3. With tuning gang fully meshed, set pointer to index mark.

OUTPUT METER: Connect across speaker voice-coil terminals.

SIGNAL GENERATOR: Connect AM r-f signal generator as indicated in chart. Generator ground lead to chassis. Use modulated output.

RADIO CONTROLS: Set volume control to maximum, tone control counterclockwise, and band switch to broadcast position.

OUTPUT LEVEL: During alignment, adjust signal-generator output to hold output meter indication below 1.25 volts.

STEP	SIGNAL GENERATOR		RADIO		ADJUST TRIMMER
	CONNECTION TO RADIO	DIAL SETTING	DIAL SETTING	SPECIAL INSTRUCTIONS	
1	Through a .01- μ f. condenser to mixer grid, pin 1, of 7F8/S.	455 kc.	Gang fully meshed.	Adjust, in order given, for maximum output.	TC11—2nd AM i-f sec. TC10—2nd AM i-f pri. TC5—1st AM i-f sec. TC4—1st AM i-f pri.
2	Radiating loop. (See Note below.)	1600 kc.	1600 kc.	Adjust for maximum output.	C1D—AM osc. shunt
3	Same as step 2.	1500 kc.	1500 kc.	Adjust for maximum output.	C1B—AM ant. shunt
4	Same as step 2.	580 kc.	580 kc.	Adjust for maximum output. This should not be necessary unless T1 (aerial transformer) has been replaced.	TC1—AM ant. tuning core

RADIATING LOOP: Make up a 6-to-8 turn, 6-inch-diameter loop, using insulated wire; connect to signal generator leads and place near radio loop aerial.

FM ALIGNMENT PROCEDURE

Make the AM alignment first.

RADIO CONTROLS: Set volume control to maximum, tone control counterclockwise, and band switch to FM position. Allow radio and signal generator to warm up for at least 15 minutes before making alignment.

SIGNAL GENERATOR: Use a signal generator capable of delivering a 9.1-mc. FM signal with a deviation of ± 80 kc., and modulated AM signals of 92 mc., 105 mc., and 108 mc. Philco Model 7008 Precision Visual Alignment Generator fulfills these requirements. **NOTE:** The signal generator must be well bonded to radio chassis.

OSCILLOSCOPE: Connect to FM Test jack. Model 7008 is suggested.

OUTPUT METER: Connect across speaker voice-coil terminals.

R-F COIL NOTE: Check resonance of circuits containing coils L1, L2, and L3 by inserting each end of a tuning wand, such as Philco Part No. 45-8885, into coil. If signal strength increases when powdered-iron end is inserted, compress turns slightly. If signal strength increases when brass end is inserted, spread turns slightly. If signal strength decreases when each end is inserted, no adjustment is necessary. Do no spread or compress turns excessively; only a small change is required at these high frequencies.

STEP	SIGNAL GENERATOR		RADIO		ADJUST TRIMMER
	CONNECTION TO RADIO	DIAL SETTING	DIAL SETTING	SPECIAL INSTRUCTIONS	
1	Through a .01- μ f. condenser to pin 1 of 6AU6 I-F amplifier.*	9.1 mc. ± 80 kc. deviation.	Gang fully meshed.	Adjust TC9 for correct crossover. Adjust TC8 for maximum and equal peaks. Repeat.	TC9—FM det. sec. TC8—FM det. pri.
2	.01- μ f. condenser to pin 1 of 6BA6.*	9.1 mc. ± 80 kc. deviation.	Gang fully meshed.	Adjust, in order given, for maximum and equal peaks. Repeat.	TC7—FM 2nd i-f sec. TC6—FM 2nd i-f pri.
3	.01- μ f. condenser to pin 1 of 7F8/S.*	9.1 mc. ± 80 kc. deviation.	Gang fully meshed.	Adjust, in order given, for maximum and equal peaks. Repeat.	TC3—FM 1st i-f sec. TC2—FM 1st i-f pri.
4	Through a 300 ohm dummy aerial to FM aerial socket, J1.	108 mc.	108 mc.	Adjust trimmer for maximum reading on output meter.	C1B—FM osc.
5	Same as step 4.	105 mc.	105 mc.	Adjust for maximum output while rocking gang.	C1C—FM r-f C1A—FM aerial
6	Same as step 4.	92 mc.	92 mc.	Adjust coils, in order given, for proper resonance	L3—FM osc. coil L2—FM r-f coil L1—FM aerial coil

*CAUTION: Do not overload! When aligning the i-f stages, the curve will be distorted or destroyed if too great a signal is used. To check, attenuate the signal input. If the curve changes in form, rather than merely decreasing in amplitude, the stage is overloaded.

MANUAL OF 1951 MOST-OFTEN-NEEDED RADIO DIAGRAMS

RCA VICTOR

MODELS 45-EY-1, 45-EY-15

Chassis Nos. RS-132F, RS-132H

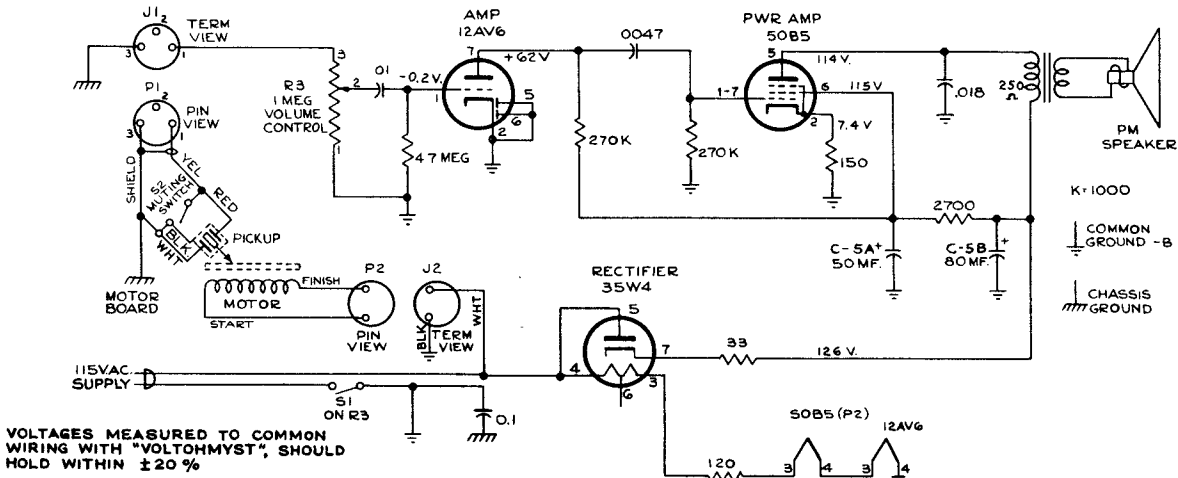

RCA VICTOR

MODEL 45-EY-3

Chassis No. RS-136, RS-136A

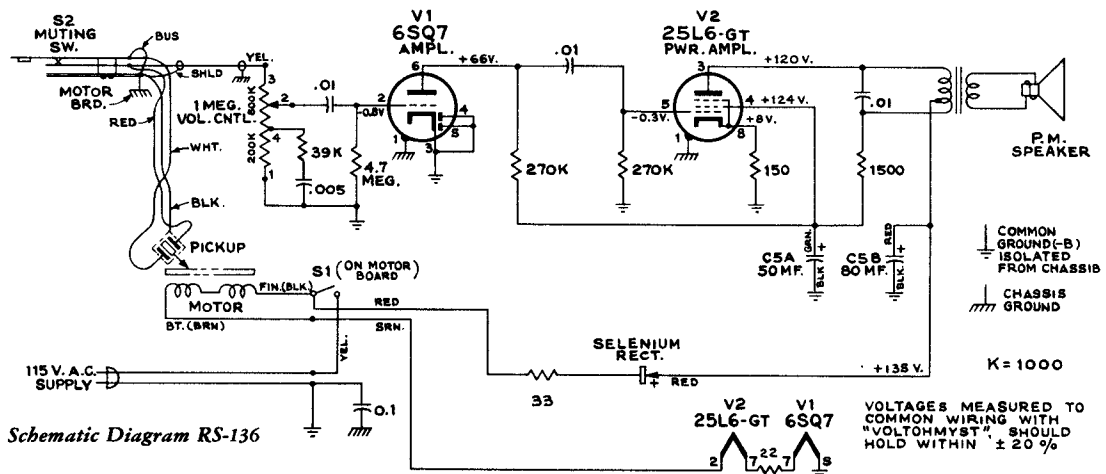

Schematic Diagram RS-136

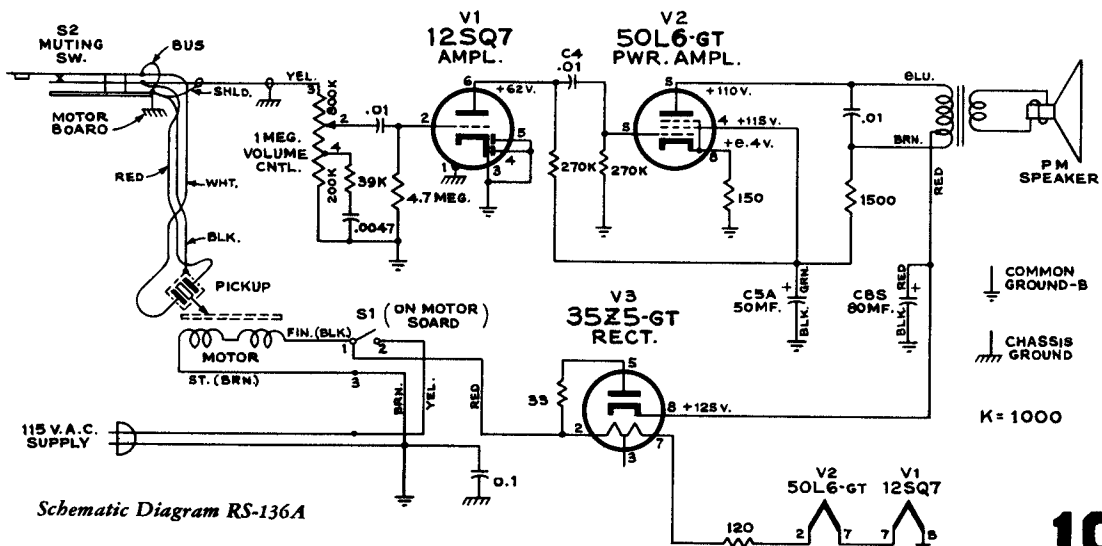

Schematic Diagram RS-136A

MANUAL OF 1951 MOST-OFTEN-NEEDED RADIO DIAGRAMS



RCA VICTOR

Automatic Record Player

MODEL 45-EY-2

Chassis No. RS-138, RS-138A

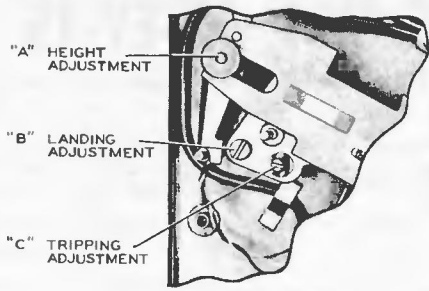

Pickup Height Adjustment

Adjust knurled nut (A) until the distance (during change cycle) between the top of the turntable and the stylus point is approximately $1\frac{1}{4}$ "

Pickup Landing Adjustment

Adjust the screw driver landing adjustment stud "B" so the stylus lands $2\frac{3}{4}$ " \pm $\frac{1}{64}$ " from the side of the center post.

Tripping Adjustment

Adjust the eccentric tripping stud (C) until the mechanism trips when the stylus is $1\frac{3}{32}$ " from the side of the center post.

Stop Dog Adjustment

Turn the eccentric screw (E) until the record drops to the turntable without striking the pickup arm.

Critical Lead Dress

1. Dress all leads away from R6 and R9
2. Dress electrolytic capacitor away from R6 and R9
3. Dress filament leads down to chassis
4. Solder braid of W-1 such that it acts as a strain relief

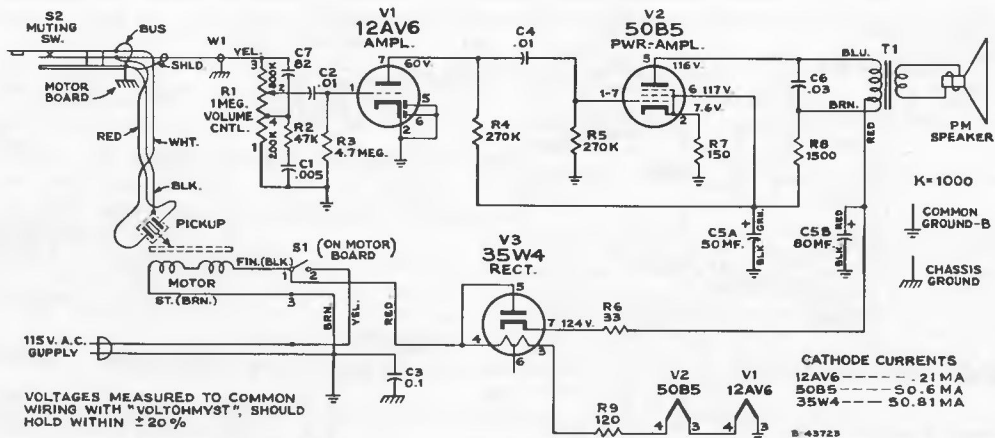
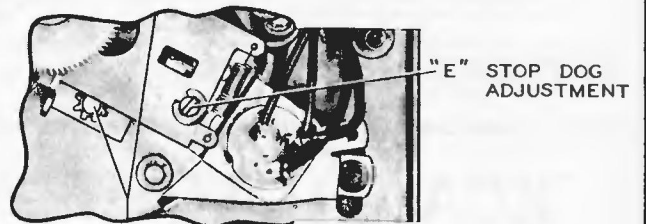

Schematic Diagram RS138

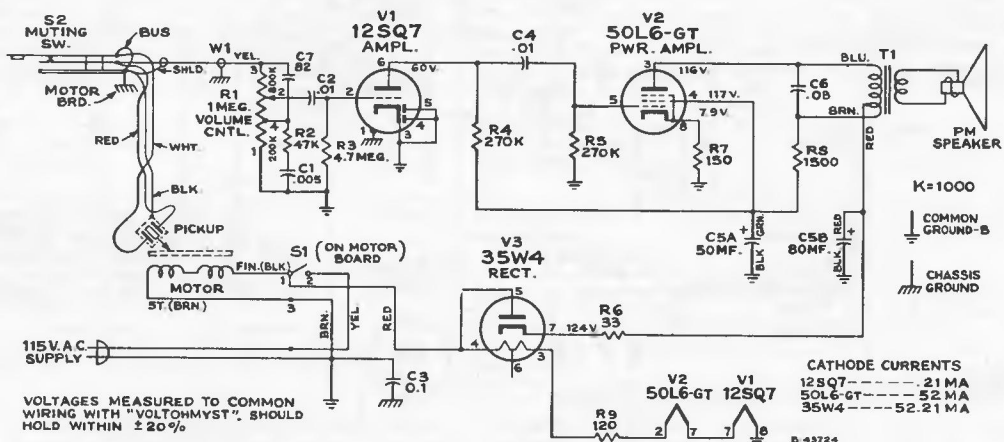

Schematic Diagram RS138A

RCA VICTOR MODEL BX57

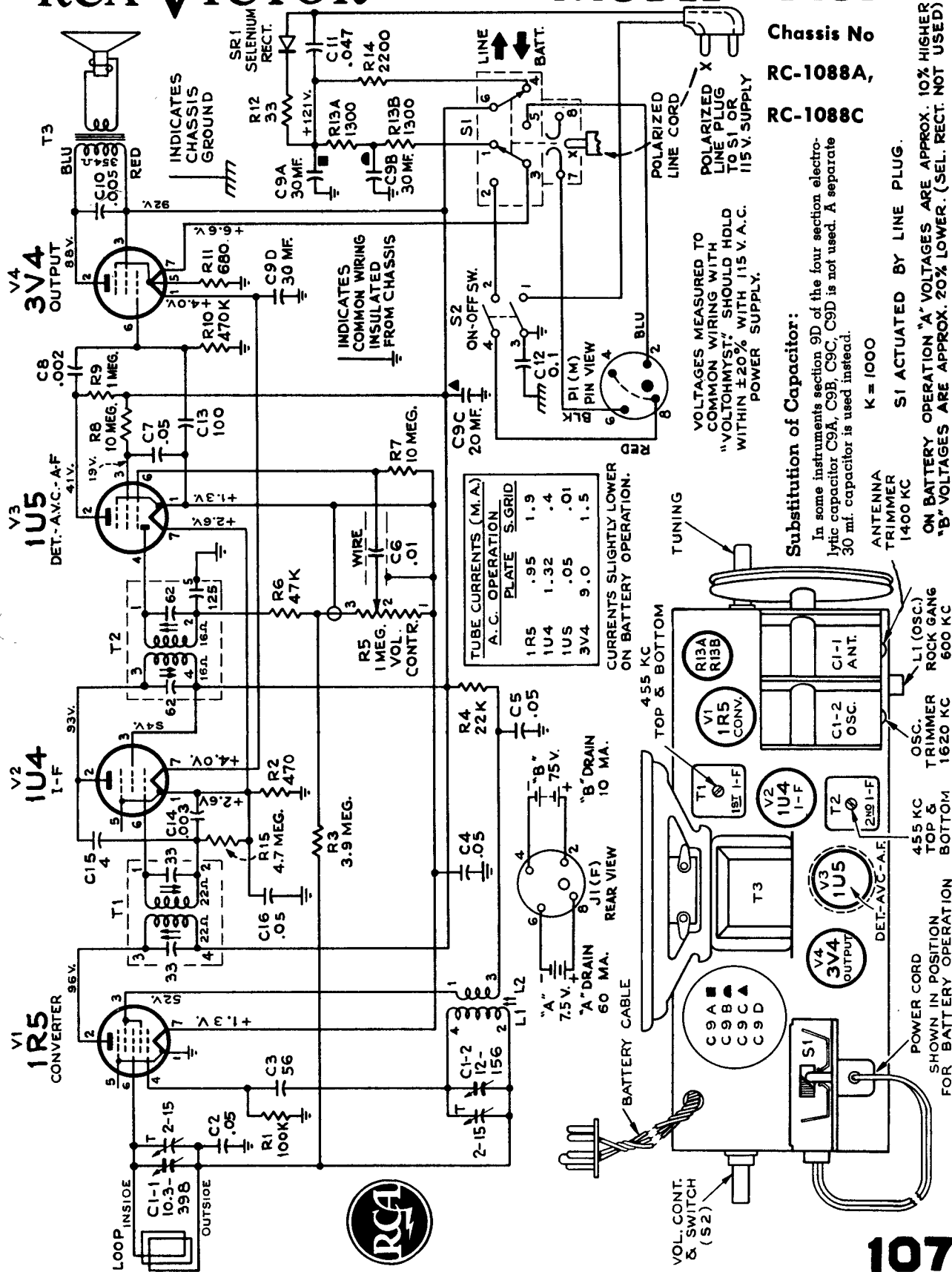



RCA VICTOR

MODEL B-411

Chassis No. RC-1098 or RC-1098A

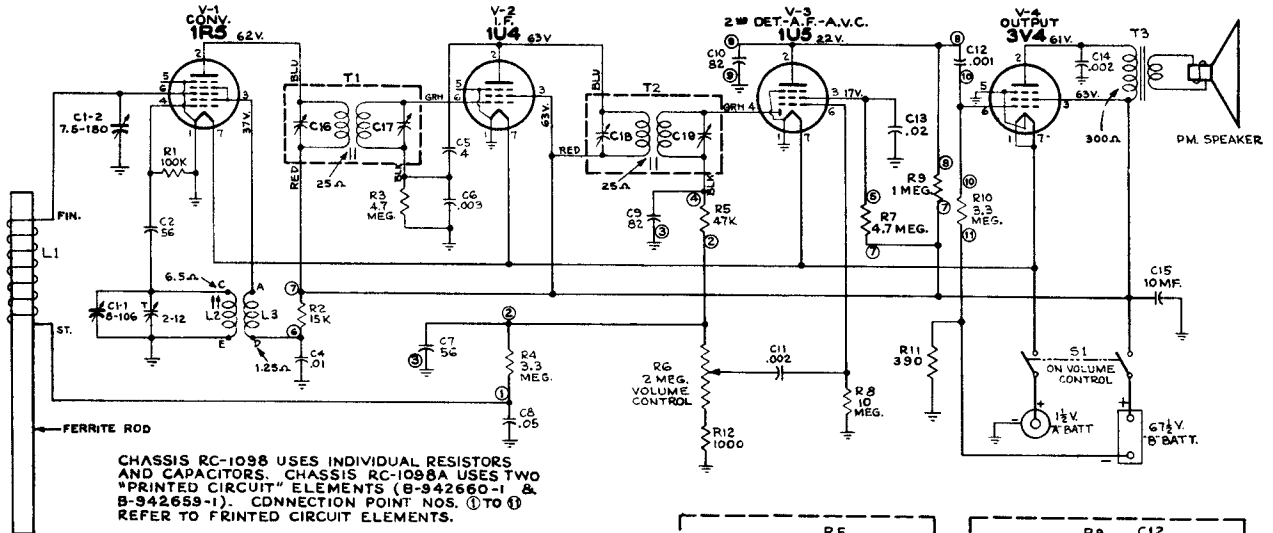

CHASSIS RC-1098 USES INDIVIDUAL RESISTORS AND CAPACITORS. CHASSIS RC-1098A USES TWO "PRINTED CIRCUIT" ELEMENTS (B-942660-1 & B-942659-1). CONNECTION POINT NOS. ① TO ⑩ REFER TO PRINTED CIRCUIT ELEMENTS.

ALL RESISTANCE VALUES IN OHMS. K = 1000. ALL CAPACITANCE VALUES LESS THAN 1.0 IN MF. AND ABOVE 1.0 IN MMF. UNLESS OTHERWISE INDICATED.

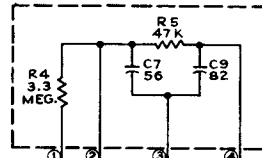
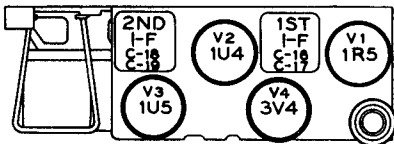

DIODE FILTER UNIT
B 942660-1

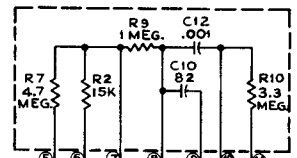

AUDIO COUPLING UNIT
B 942659-1

Output Meter.—Connect meter from No. 2 terminal of V4 (plate of 3V4) to ground. Turn volume control to maximum position.

Test-Oscillator.—For all alignment operations, connect the low side of the test-oscillator to the receiver chassis, and keep the oscillator output as low as possible to avoid a-v-c action.

Note.—The inductance of the antenna coil is adjusted by sliding the coil along the Ferrite rod. This ant. coil is supplied pre-adjusted and cemented to rod. This makes further adjustment unnecessary.

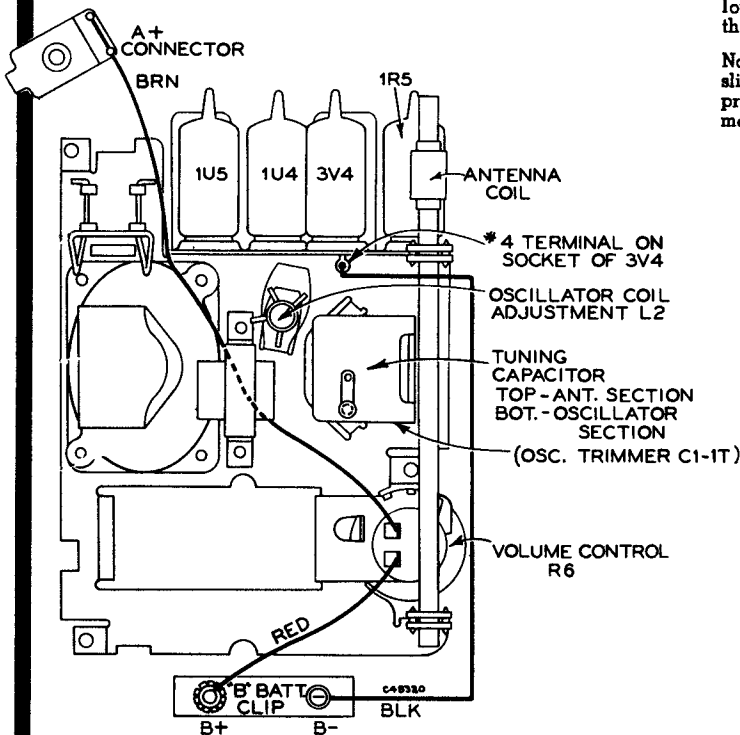

Steps	Connect the high side of test osc. to—	Tune test-osc. to—	Turn radio dial to—	Adjust the following for max. peak output—
1				C18, C19 2nd I-F trans.
2	Connection lug of C1-2 located on rear of gang in series with .01 mf.	455 kc	Quiet point near 1600 kc	C18, C17 1st I-F trans.
Repeat steps 1 and 2				
4		1400 kc	14 Rock gang	C1-1T (osc.)
5	*Antenna coupling loop (Chassis in case)	600 kc	60 Rock gang	L2 (osc.)
6				Repeat steps 4 and 5

*Steps 4 and 5 require a coupling loop from the signal generator to feed a signal into the receiver ant. coil. This loop should be loosely coupled to the receiver antenna coil so as not to disturb the receiver ant. coil inductance.

MANUAL OF 1951 MOST-OFTEN-NEEDED RADIO DIAGRAMS

MODEL A-108

Chassis No. RC 1096

Record Changers 960284 (78/33 1/3 r.p.m.)
RP 168 or RP 190-2 (45 r.p.m.)



MODEL A-101

Chassis No. RC 1096

Record Changers 960282-4 or 5 (78/33 1/3 r. p. m.)
and RP 190-2 (45 r.p.m.)

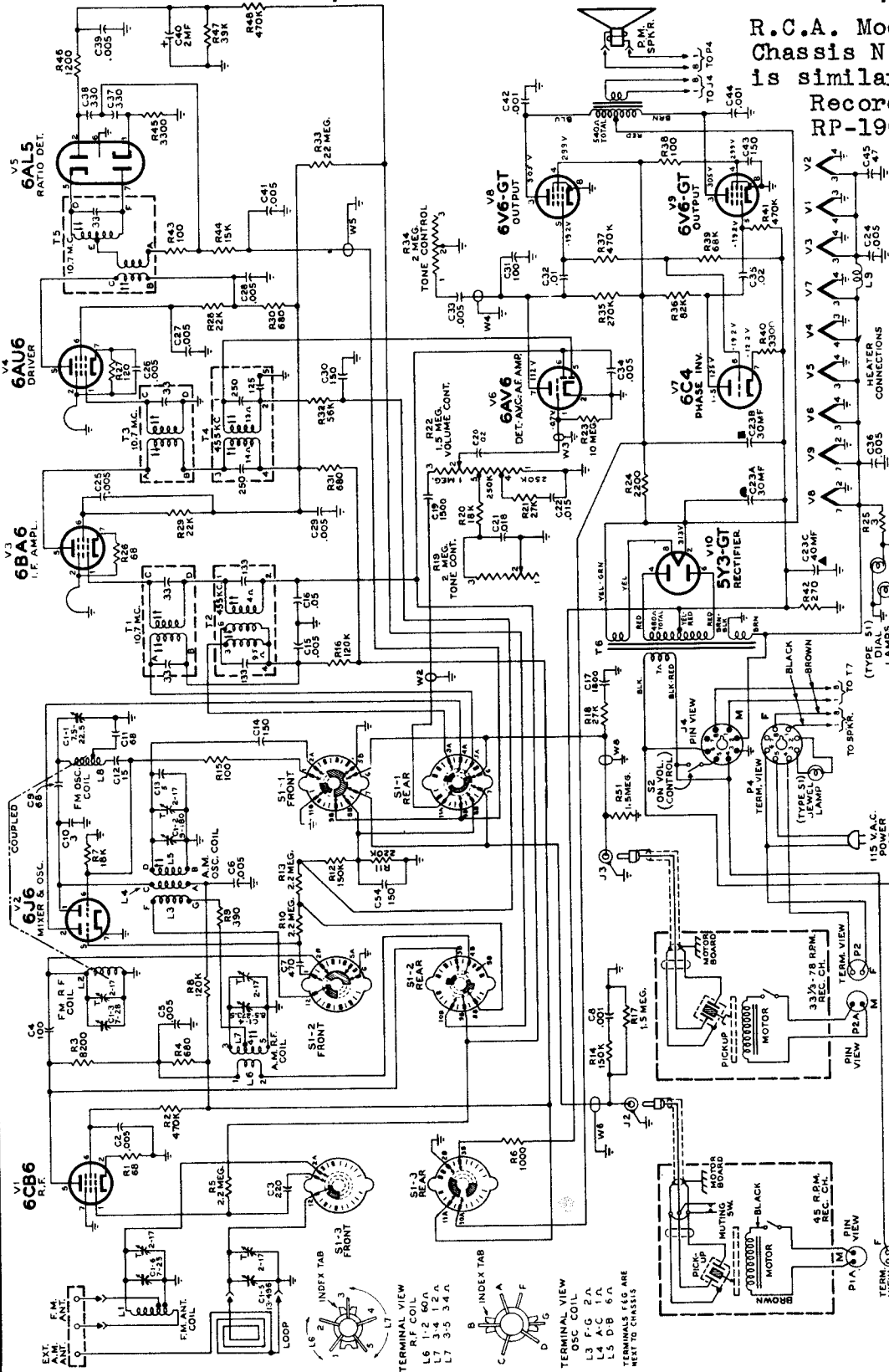

R.C.A. Model 45-W-10, Chassis No. RC-1096A, is similar, but uses Record Changer RP-190-2 (45 rpm) only.



Function switch viewed from front and shown in "Phono 78/33" position (max. c/clockwise).
CAPACITOR VALUES LESS THAN 1 ARE IN MF. VALUES GREATER THAN 1 ARE IN MMF. UNLESS OTHERWISE SPECIFIED.
RESISTANCE VALUES IN OHMS. X = 1000.VOLTAGES MEASURED TO CHASSIS WITH VOLTOHMIST WITH NO SIGNAL INPUT AND SHOULD HOLD WITHIN ±20% WITH 117-VOLT Standard Broadcast (AM) 540-1,800 kc.
Frequency Modulation (FM) 88-108 mc.
Intermediate Frequencies AM—455 kc, FM—10.7 mc.

MANUAL OF 1951 MOST-OFTEN-NEEDED RADIO DIAGRAMS



RCA VICTOR

AC-DC Radio Receiver

MODELS X551, X552

Chassis No. RC-1089B RC-1089C



X551
Maroon

X552
Ivory

Change in Schematic Diagram:

Resistor R4 (3.3 meg. a.v.c. filter), previously connected to the junction of R12 (47K) and the phono jack (J1), is now connected to the junction of R12 and terminal #2 of the 2nd I-F transformer. The revised connection is illustrated below.

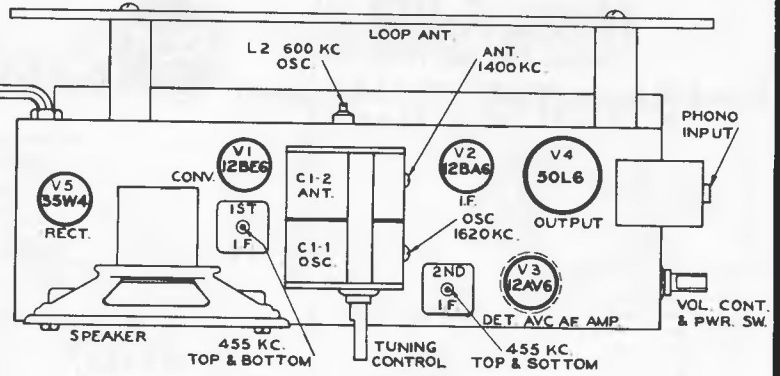

Tube and Trimmer Locations

Alignment Procedure

Test-Oscillator—For all alignment operations, connect the low side of the test-oscillator to the receiver chassis, and keep the oscillator output as low as possible to avoid a-v-c action.

On a.c. operation an isolation transformer (115 v./115 v.) may be necessary for the receiver if the test oscillator is also a.c. operated.

Steps	Connect the high side of test-oscillator to—	Tune test-osc. to—	Turn radio dial to—	Adjust the following for max. output
1	12BA6 I-F grid through .01 mfd. capacitor	455 kc	Quiet-point 1600 kc end of dial	T2 (top and bottom) 2nd I-F trans.
2	Stator of C1-2 through .01 mfd.			T1 (top and bottom) 1st I-F trans.
3	Short wire placed near loop to radiate signal	1620 kc	Min. cap.	osc. trimmer
4		1400 kc	1400 kc signal	ant. trimmer
5		600 kc	600 kc signal	L2 (osc.) Rock gang
6		Repeat steps 3, 4 and 5.		

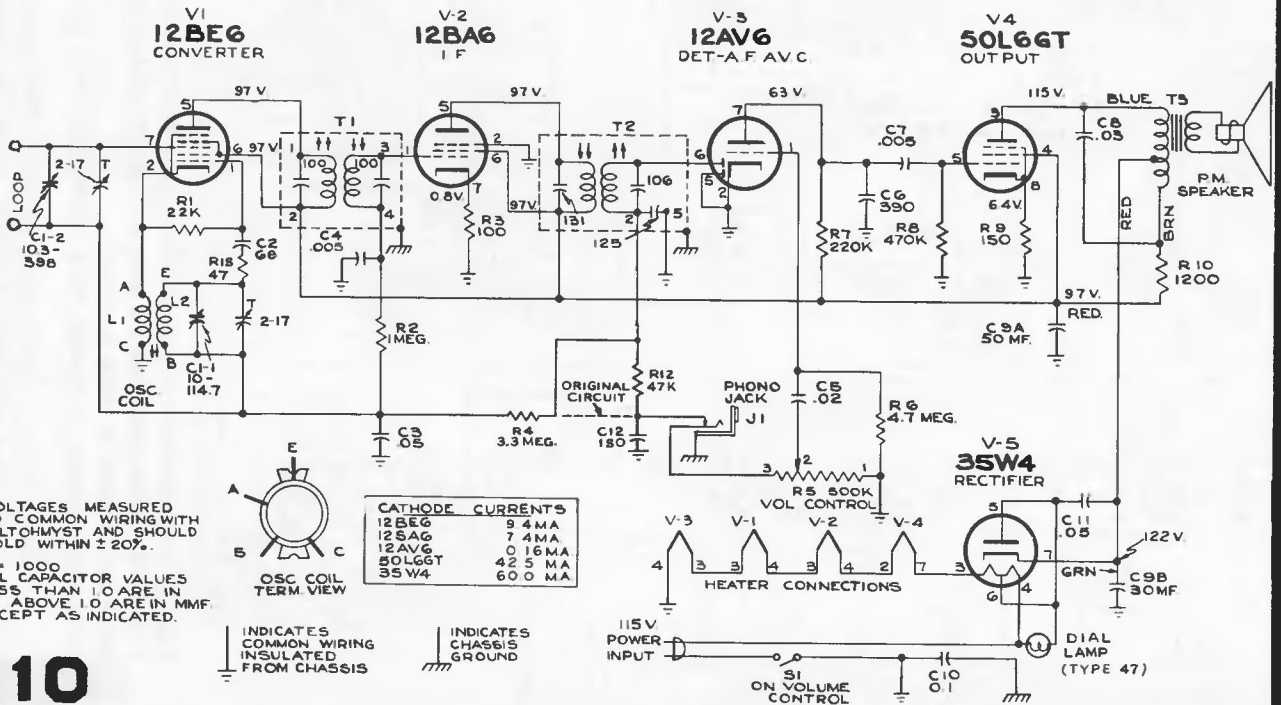

MANUAL OF 1951 MOST-OFTEN-NEEDED RADIO DIAGRAMS



RCA VICTOR

RP-190 Series

45 R.P.M. Automatic Record Changer



MODEL IDENTIFICATION

- RP190-1 Uses pickup Stock No. 75476.
RP190-2 Same as RP190-1, except use pickup Stock No. 75575.
RP190-3 Same as RP190-1, except use 85 volt motor Stock No. 75937.
RP190-4 Same as RP190-1, except "ON-OFF" switch; however, they are physically interchangeable.

LUBRICATION

A light machine oil (SAE No. 10) should be used to oil the bearings of the drive motor.

On all bearing surfaces, excepting the motor bearings, Houghton STA-PUT No. 320, or equivalent, should be used. On all other sliding surfaces, STA-PUT No. 512, or equivalent, is recommended.

(Do not oil or grease record separator shelves.)

It is important that the drive motor spindle and the rubber tire on the idler wheel be kept clean and free from oil or grease, dirt, or any foreign material at all times. Carbon tetrachloride or naphtha is satisfactory for cleaning these parts.

CAUTION

1. Avoid handling the pickup arm when the mechanism is in cycle.
2. Do not use force to release a jam.
3. Do not try to remove the records on the turntable if the turntable is stopped in cycle.
4. If the separator knives protrude from the center post when the mechanism is out of cycle, push the "start-reject" knob to reject and the condition should be corrected automatically.

AUTOMATIC OPERATION

1. Place a stack of records over the center post, with the desired selections upward, the last record to be played on top.
2. Push the "start-reject" knob to "start" (forward) and release. The mechanism will automatically play in sequence one side of each record stacked on the separator shelves.
3. To reject a record being played, push the "start-reject" knob.
4. At conclusion of playing and as the last record is being repeated, lift the pickup arm and place on its rest. Turn off the power to the drive motor by pushing back on control knob.
5. Remove the stack of records by lifting them straight up.

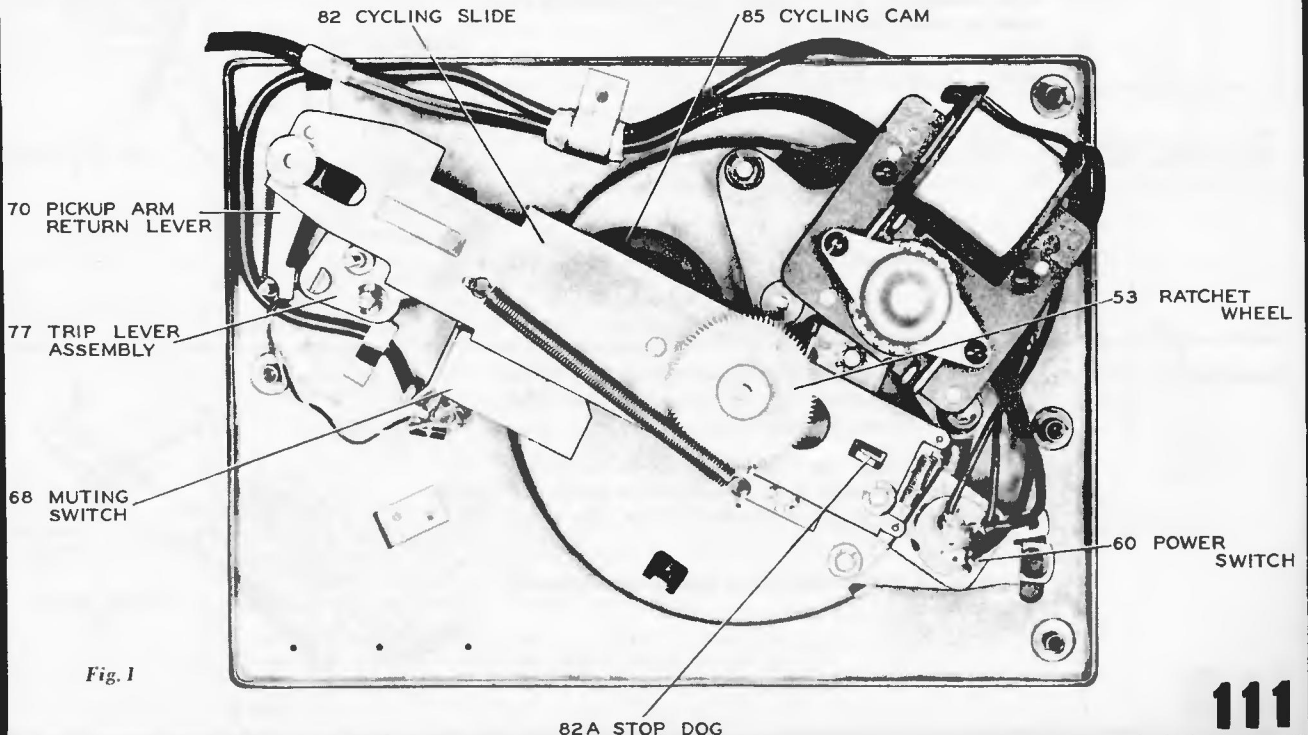

Fig. 1

MANUAL OF 1951 MOST-OFTEN-NEEDED RADIO DIAGRAMS

RP-190 Series

Function of Principal Parts

Trip Lever (77)

The trip lever is mounted on the bottom end of the pickup arm vertical pivot shaft. The function is to transfer the movement of the pickup arm to parts of the operating mechanism below the motor board. The end of the trip lever contacts stud on cycling cam thereby starts tripping action.

Pickup Arm Return Lever (70)

The function of the pickup arm return lever is to provide a force necessary to push the pickup into landing position. The end of the pickup arm return lever is curved so as to provide a stop for trip lever. This stop determines landing position of the pickup.

Reject Lever (22)

The function of the reject lever is to transfer the action of the control knob to the cycling cam thereby starting a change cycle.

Muting Switch (68)

The function of the muting switch is to short the pickup leads to prevent amplifying of mechanical noise, of the mechanism during change cycle.

Cycling Cam (85)

The cycling cam is mounted on the cycling slide. The function of the cam is to transfer the rotary motion of the turntable shaft into sliding motion of the cycling slide.

Stop Dog (82A)

The stop dog is mounted on the end of cycling slide. The function of the stop dog is to engage the ratchet wheel on the separator shaft and prevent it from rotating, at the exact moment during change cycle.

Ratchet Wheel (53)

The function of the ratchet wheel located on the end of the separator shaft is to keep the separator shaft stationary at the proper time, so as to actuate the separator mechanism inside the centerpost.

Cycling Slide (82)

The cycling slide is the main connecting medium between the various moving parts.

Cycle of Operation

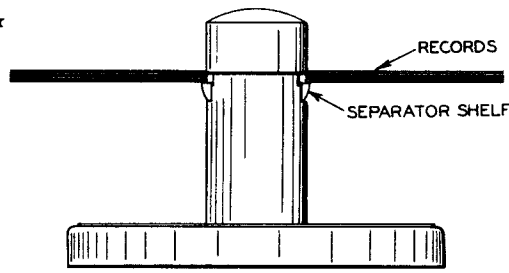
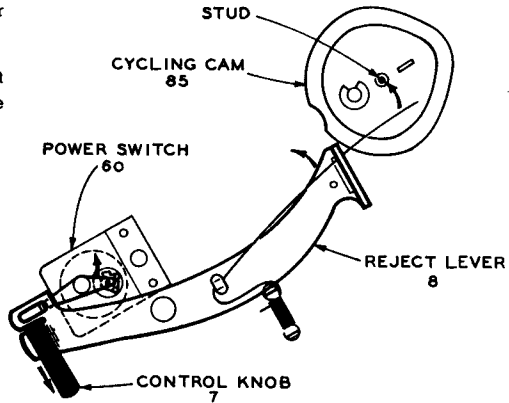
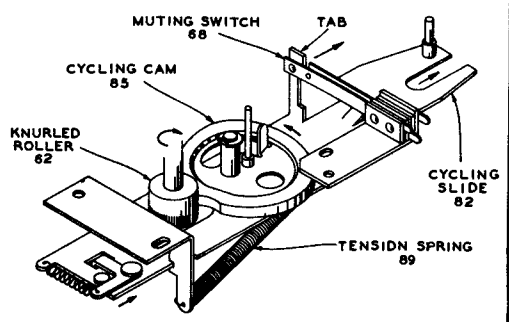
FUNCTION	EXPLANATION
Place a stack of records over centerpost.	<ol style="list-style-type: none"> 1. Records rest on separator shelves protruding from either side of the centerpost.  <p style="text-align: center;">Fig. 3</p>
Push control knob to reject.	<ol style="list-style-type: none"> 1. The control first actuates the power switch applying power to the drive motor. This starts the turntable rotating. 2. Further movement of the control knob actuates the reject lever assembly (8) which contacts the stud mounted on the eccentric cycling cam and moves it slightly.  <p style="text-align: center;">Fig. 4</p>
Cycling starts.	<ol style="list-style-type: none"> 1. The slight movement of the eccentric cycling cam (85) is sufficient for engagement with the rotating knurled roller (62) mounted on turntable shaft. 2. The eccentric cycling cam which is mounted on the cycling slide (82) pushes the slide in the direction of the pickup arm pivot. In so doing tension is increased on the slide return spring (89). 3. The tab on the cycling slide moves back permitting muting switch to close.  <p style="text-align: center;">Fig. 5</p>

MANUAL OF 1951 MOST-OFTEN-NEEDED RADIO DIAGRAMS

Cycle of Operation—Continued

RP-190 Series

Pickup raises from the rest.

1. As the cycling slide continues to move in the direction of the pickup arm pivot the small incline pressed in the slide causes the elevating rod (74) to lift the pickup arm from the rest.
2. The raised pickup arm moves inward slightly from the inward force of the pickup arm return lever (70), until the stud on the trip lever (77) assembly comes against edge of the cycling slide.
3. The cycling slide continues to move further, which pushes the trip lever back. The eccentric landing adjustment stud (79) contacts and pushes the pickup arm return lever (70) against the tension of the return spring (69).

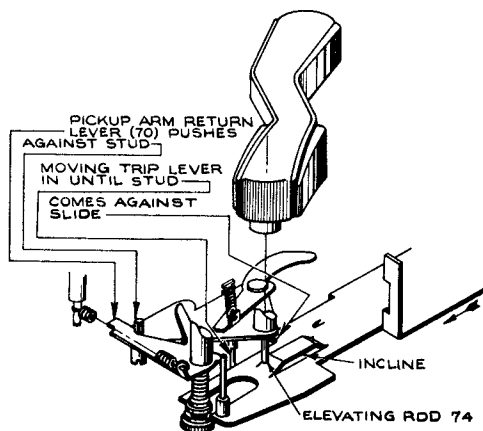

Fig. 7

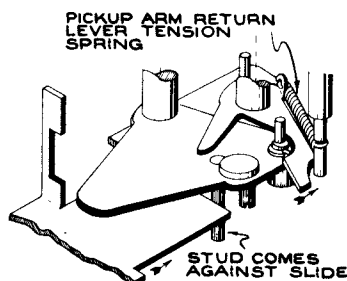

Fig. 6

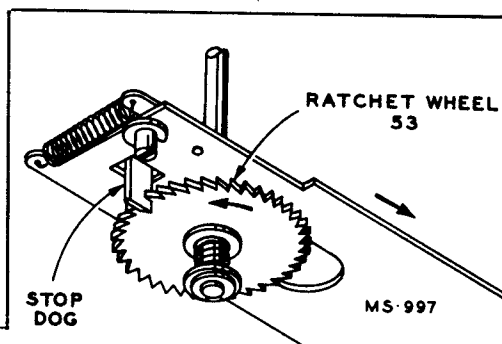

Fig. 8

Separator knives separate the lower record from the stack and the lower record drops to the turntable.

1. As the cycling slide reaches the limit in its movement in the direction of the pickup arm pivot, the stop dog mounted on the slide engages the rotating ratchet wheel (53).
2. The ratchet wheel and separator shaft (6) then remains stationary and the turntable continues to rotate.
3. The separator shelves and knives are coupled together in such a manner that the flattened end of the separator shaft pushes the knives out, which in turn pulls the opposite shelves in.
4. As the shelves recede, the separator knives mounted above the shelves move out and separate the lower record of the stack and support the remaining records while the lower record drops to the turntable.

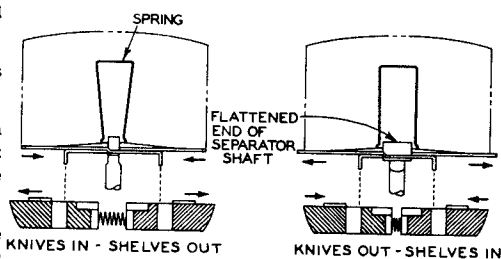

Fig. 9

Pickup moves in for landing.

1. The cycling slide moves away from the pickup arm pivot, due to the force produced by the tension spring (89) keeping the eccentric cycling cam against the rotating knurled roller (62). The knurled roller at this time is returning to the smaller diameter of the cam.
2. The stud on trip lever assembly follows the slide due to the force produced by the action of the pickup arm return lever.
3. After the slide has moved back a short distance the stud on the trip lever assembly no longer follows the slide since the landing adjustment stud comes against the curved stop on the end of the pickup arm return lever. At this moment the pickup is directly above the point of landing.
4. As the cycling slide completes the return movement the elevating rod slides down the incline which lowers the stylus on the record.

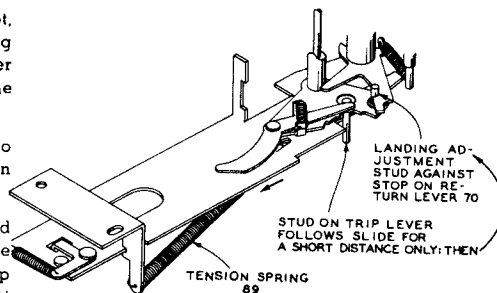

Fig. 10

MANUAL OF 1951 MOST-OFTEN-NEEDED RADIO DIAGRAMS

RP-190 Series

Cycle of Operation—Continued

Cycle completed and the record plays.

1. The tab on the cycling slide contacts and opens the muting switch.
2. The stud on the cycling slide pushes pickup arm return lever back to permit free motion of the pickup arm.
3. The change cycle is completed as the cycling slide comes against the stop bracket, at which time the knurled roller rotates in the cut away section of the cam.
4. As the record plays and the pickup arm moves inward.
5. When the stylus reaches the end of the selection the end of the trip lever contacts the stud on the cycling cam, and pushes it slightly.
6. The slight movement of the cycling cam causes engagement with the rotating knurled roller, thereby starting a change cycle.
7. The mechanism repeats the preceding sequence of operations until the last record of the stack has dropped and has been played. This selection will be repeated until the pickup is lifted and placed on the rest.

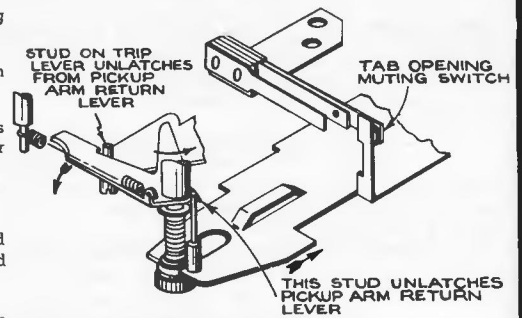

Fig. 11

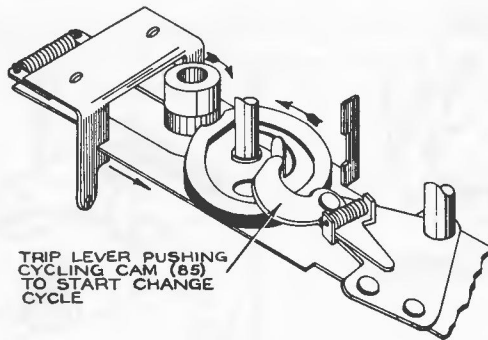

Fig. 13

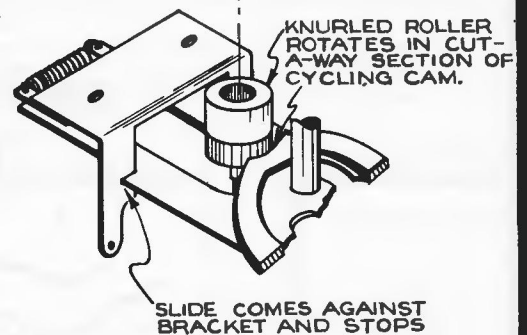

Fig. 12

DO YOU KNOW?

IF THIS SPRING IS LOOSE OR MISSING, PICKUP WILL NOT LAND PROPERLY

IF THERE IS A BIND IN THIS PIVOT, MECHANISM MAY NOT TRIP

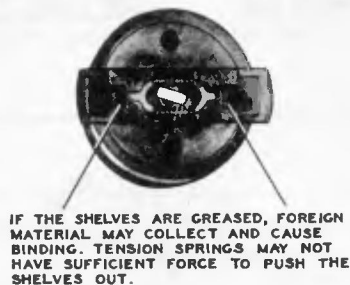

Fig. 16

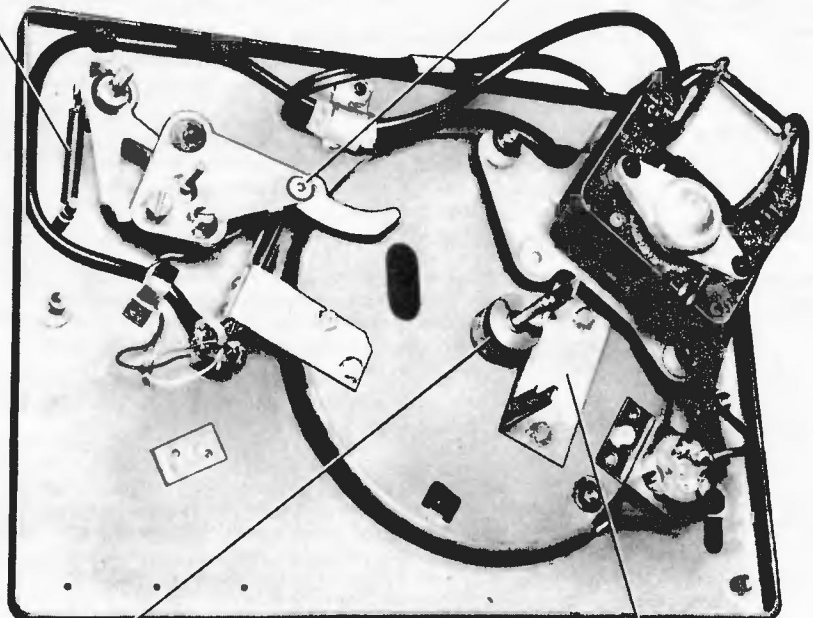

Fig. 14

IF THIS KNURLED ROLLER IS LOOSE, MECHANISM MAY FAIL TO COMPLETE CYCLE

IF THIS BRACKET IS IMPROPERLY ADJUSTED, THE CYCLING SLIDE MAY BIND OR CONTINUOUS TRIPPING MAY RESULT

REJECT CONTROL FAILS TO OPERATE

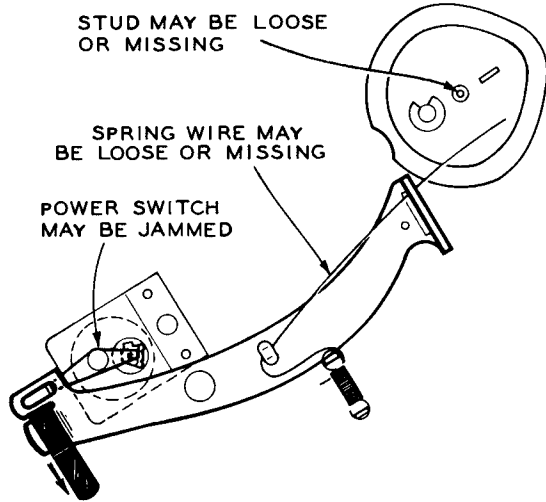

Fig. 17

RECORD STRIKES PICKUP ARM WHEN DROPPING

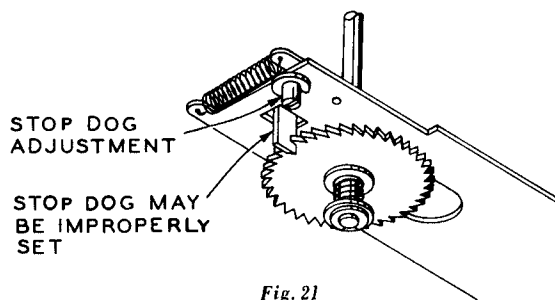
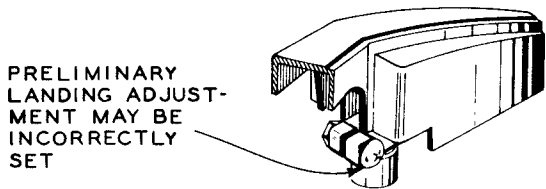

Fig. 21

PREMATURE TRIPPING

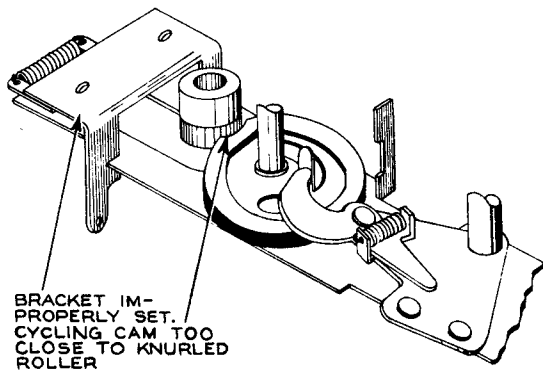

Fig. 30

MECHANISM FAILS TO SEPARATE RECORDS PROPERLY

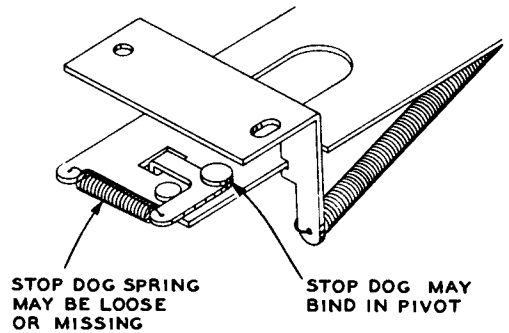

Fig. 18

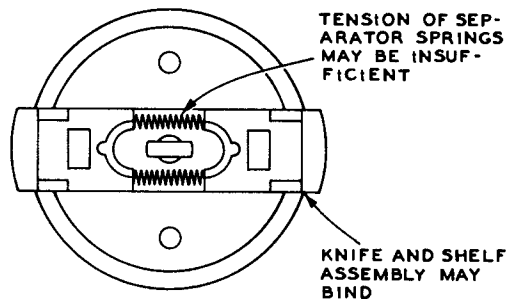

Fig. 19

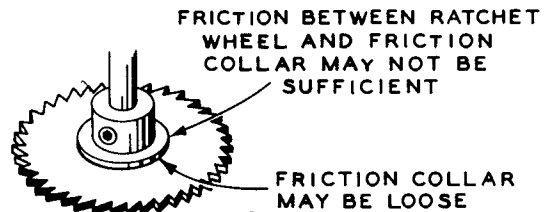

Fig. 20

PICKUP SKIPS GROOVES

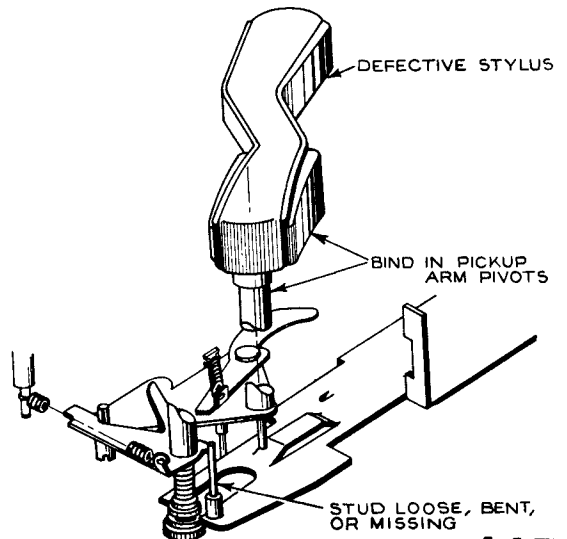

Fig. 25

MANUAL OF 1951 MOST-OFTEN-NEEDED RADIO DIAGRAMS

RP-190 Series

PICKUP FAILS TO LAND PROPERLY

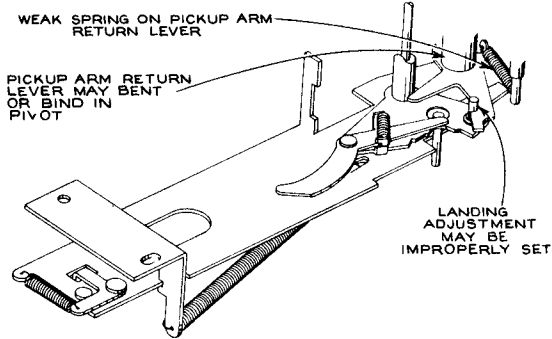

Fig. 22

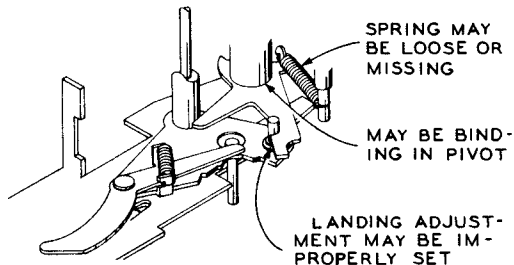

Fig. 23

CONTINUOUS TRIPPING

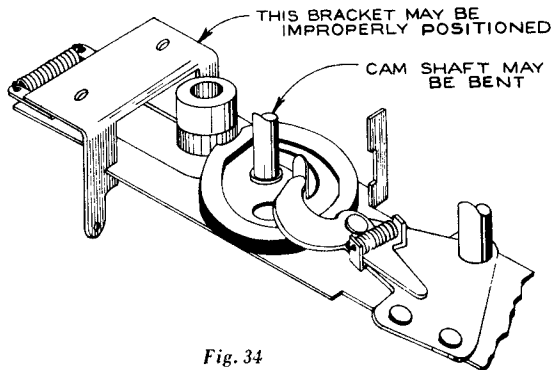

Fig. 34

MECHANISM FAILS TO TRIP

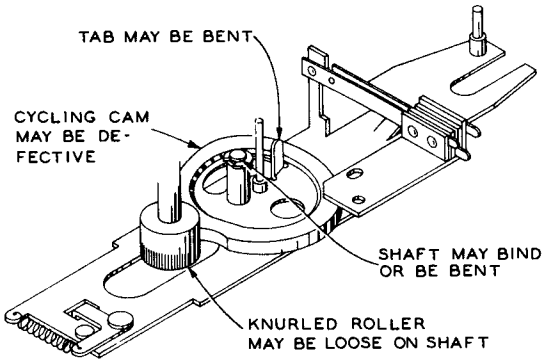

Fig. 26

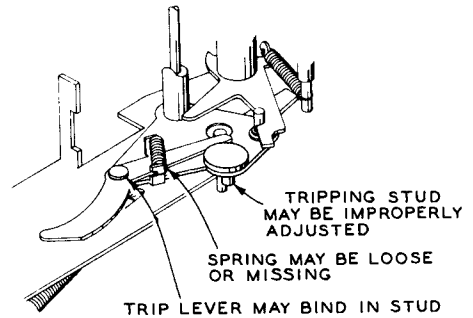

Fig. 27

MECHANISM FAILS TO COMPLETE CYCLE

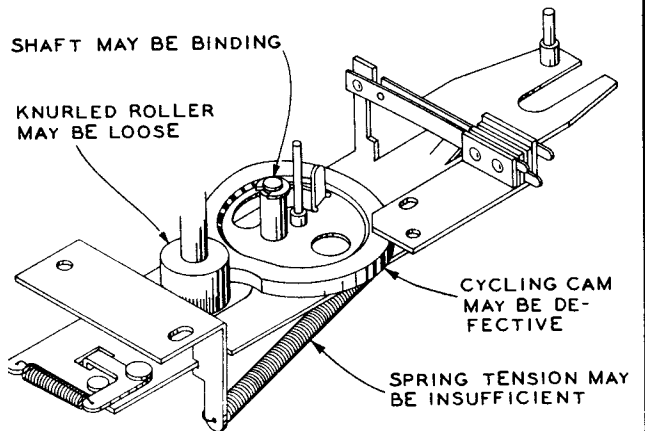

Fig. 35

ADJUSTMENTS

LANDING

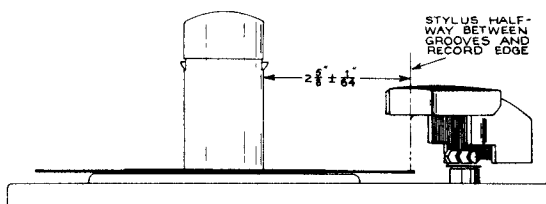

Fig. 36

TRIPPING

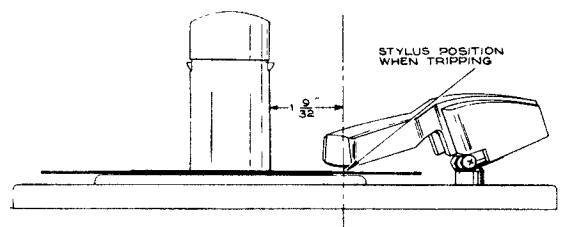

Fig. 37

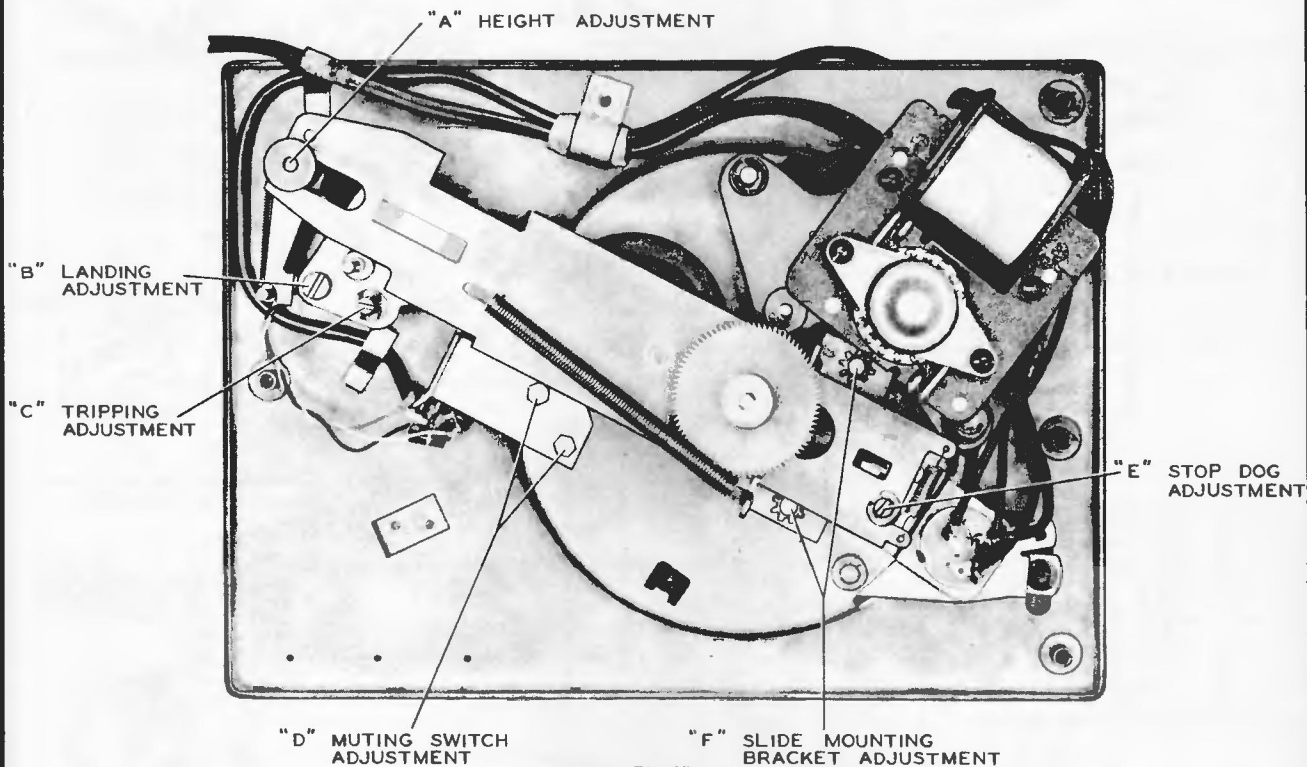

Fig. 38

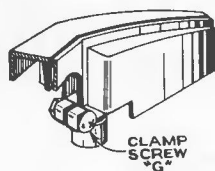

Fig. 39

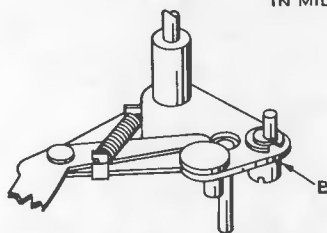

Fig. 40

LANDING ADJ.
ECCENTRIC STUD
IN MID POSITION

POSITION OF LANDING ADJ.
ECCENTRIC STUD FOR PICKUP
FURTHEREST —

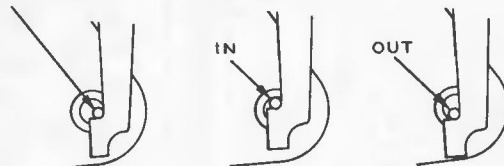

Fig. 41

Adjustments

Pickup Landing Adjustment:

Under ordinary conditions the landing adjustment is a screw-driver adjustment as shown. The adjustment of eccentric landing adjustment stud (B) gives approximately a $\frac{1}{4}$ " movement. (See Figs. 38, 40.)

If, however, the pickup arm has been removed it is first necessary to make an approximate landing adjustment as follows:

1. With the mechanism out of cycle and the clamp screw (G) (Fig. 39) loose, place pickup arm on the rest and tighten clamp screw enough to prevent the clamp from slipping on the shaft.
2. Set the landing adjustment stud (B) as shown (mid-adjustment). (See Figs. 40, 41.)
3. With the power removed, push reject control to reject. Rotate turntable by hand in the correct direction until the pickup is about ready to land.
4. Loosen clamp screw (G) and move pickup arm so the stylus is approximately $2\frac{3}{8}$ " from side of centerpost. Tighten clamp screw. (See Figs. 36, 39.)
5. Exact landing adjustment can now be made by a screw-driver on stud (B). (See Fig. 38.)

Pickup Height Adjustment (See Fig. 38):

Adjust knurled nut (A) until the distance (during change cycle) between the top of the turntable and the stylus point is approximately $1\frac{1}{8}$ ".

NOTE: If unable to adjust for sufficient height, it may be necessary to cut a few turns from the compression spring to allow more space on the shaft.

Tripping Adjustment (See Figs. 37, 38):

Adjust the eccentric tripping stud (C) until the mechanism trips when the stylus is $1\frac{9}{32}$ " from the side of the centerpost.

Mounting Bracket Adjustment (See Fig. 38):

Loosen the two screws (F) and move the bracket so it is as near perpendicular to the slide as possible. Move back or forward until the cut away section of the cycling cam clears the knurled roller approximately $1/16$ ". Tighten screws.

Muting Switch Adjustment (See Fig. 38):

Loosen the two screws (D) and adjust the position of the switch so the contacts are approximately $1/32$ to $1/16$ inches apart when the mechanism is out of cycle. If the mounting screws do not give sufficient adjustment, bend tab on slide slightly.

Stop Dog Adjustment (See Fig. 38):

Turn the eccentric screw (E) until the record drops turntable without striking the pickup arm.

MANUAL OF 1951 MOST-OFTEN-NEEDED RADIO DIAGRAMS

RP-190 Series

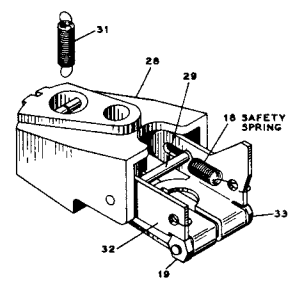
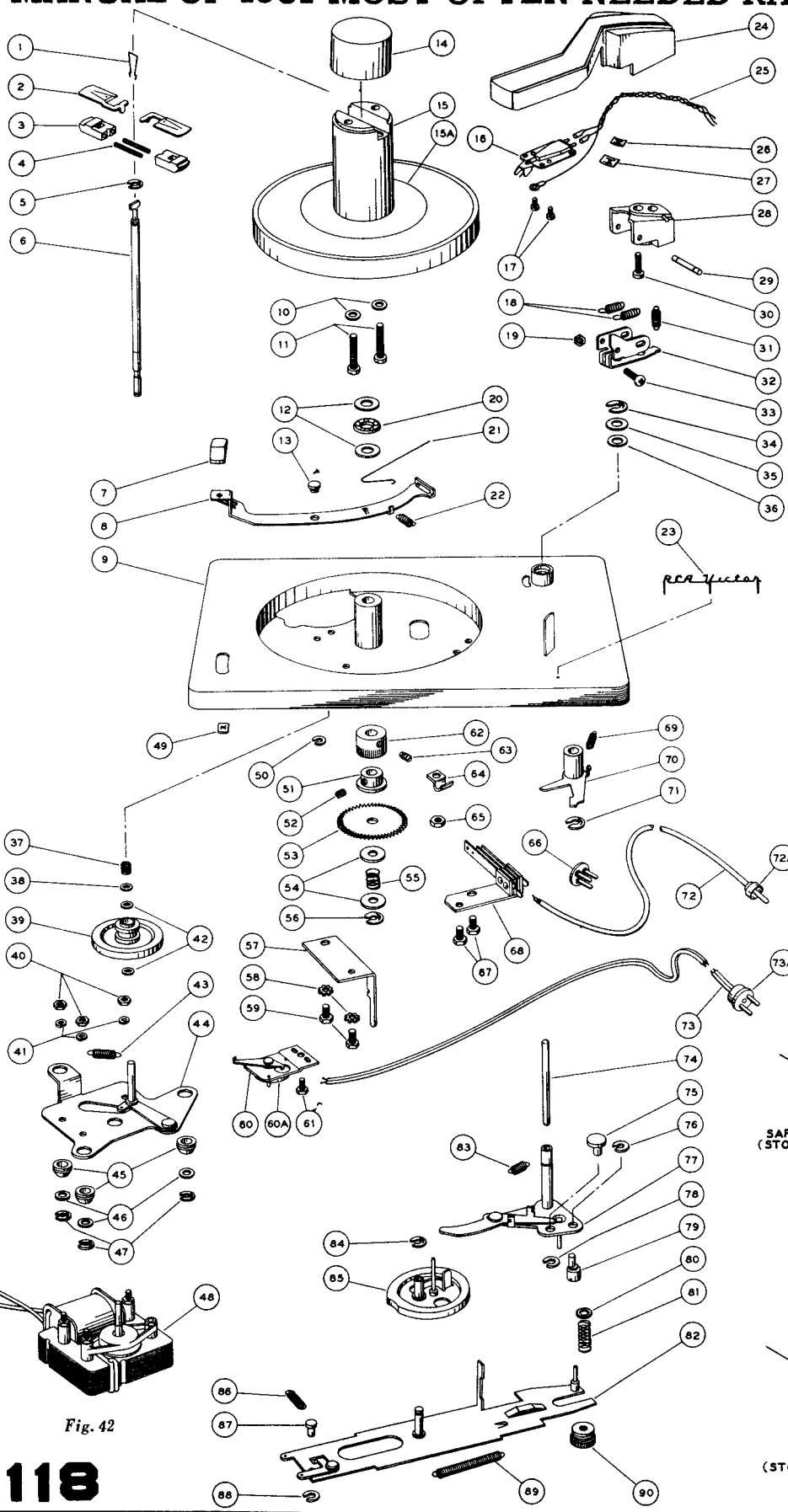

Original counterbalance and swivel assembly

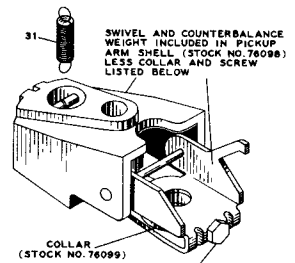

New counterbalance and swivel assembly part of pickup arm

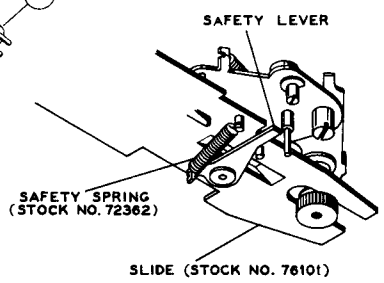

New cycling slide

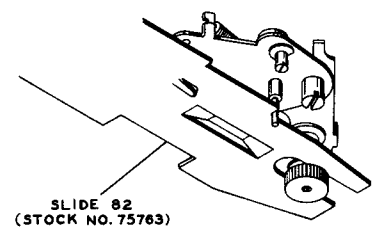

Original cycling slide

Fig. 42

MANUAL OF 1951 MOST-OFTEN-NEEDED RADIO DIAGRAMS

Silvertone

Sears, Roebuck & Co.
Set Catalog No. 4,
Chassis 478.233

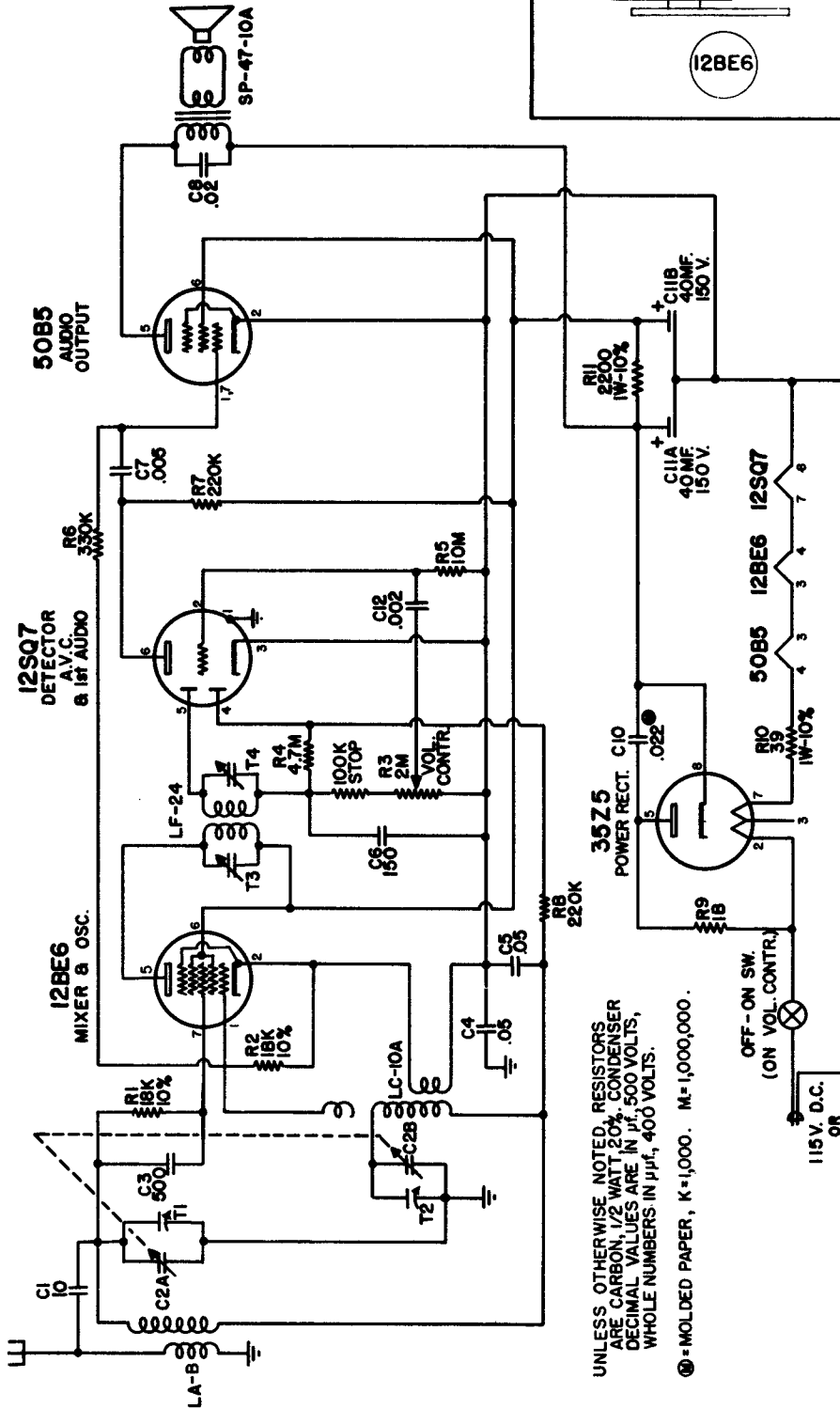
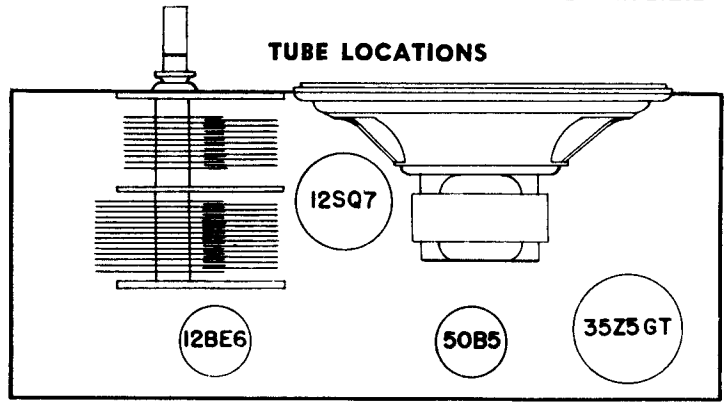

UNLESS OTHERWISE NOTED, RESISTORS ARE CARBON, 1/2 WATT, 50% CONDENSER DECIMAL VALUES ARE IN μ F, 500 VOLTS, WHOLE NUMBERS IN μ F, 400 VOLTS.

Ⓞ = MOLDED PAPER, K=1,000. M=1,000,000.

ALIGNMENT PROCEDURE

Position of Tuner	SIGNAL GENERATOR			Trimmer Adjustments (In order shown)
	Frequency	Coupling Factor	Ground Connection	
Rotor Full Open (Plates out of mesh)	455 kc.	.1 mfd	Grid of 12BE6 (Pin 7)	Input and Output Trimmers on I.F. Can T3 and T4
Rotor Full Open (Plates out of mesh)	1620 kc.	.1 mfd	Grid of 12BE6 (Pin 7)	Oscillator Trimmer T2
1400 kc.	75 mmf	Antenna Hank	Antenna Hank	Antenna Trimmer T1
600 kc.	75 mmf	Antenna Hank	Antenna Hank	(Check Point) *

MANUAL OF 1951 MOST-OFTEN-NEEDED RADIO DIAGRAMS

Silvertone

4 TUBE BATTERY-AC-DC SUPERHETERODYNE PORTABLE RECEIVER

Set Catalog No. 215

Chassis 528.174

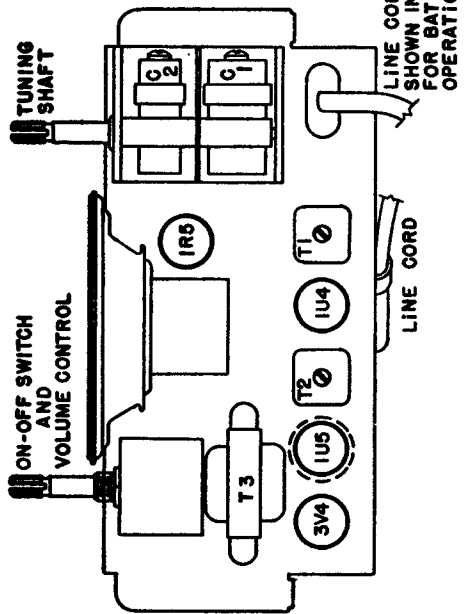
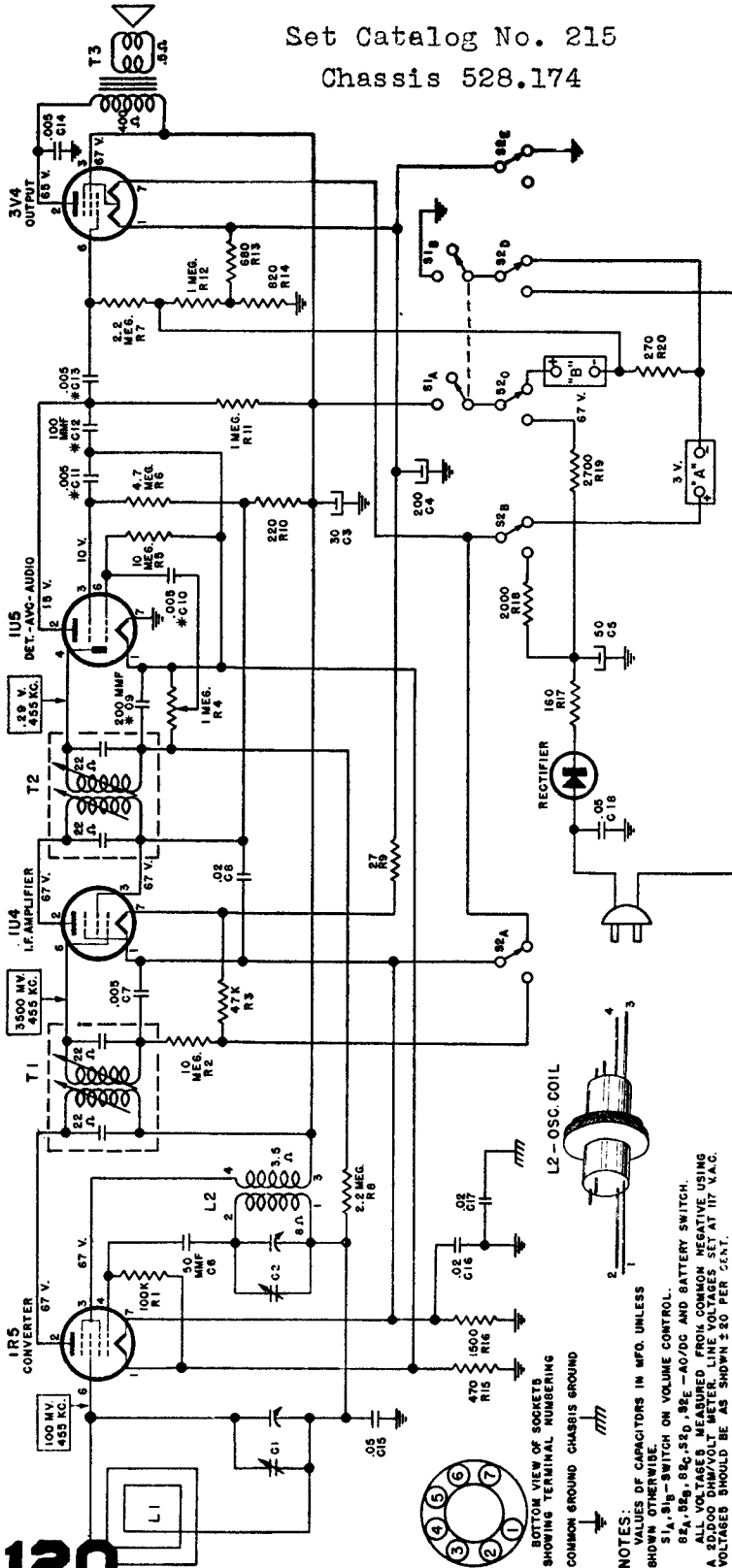

LOCATION OF PARTS ON TOP OF CHASSIS

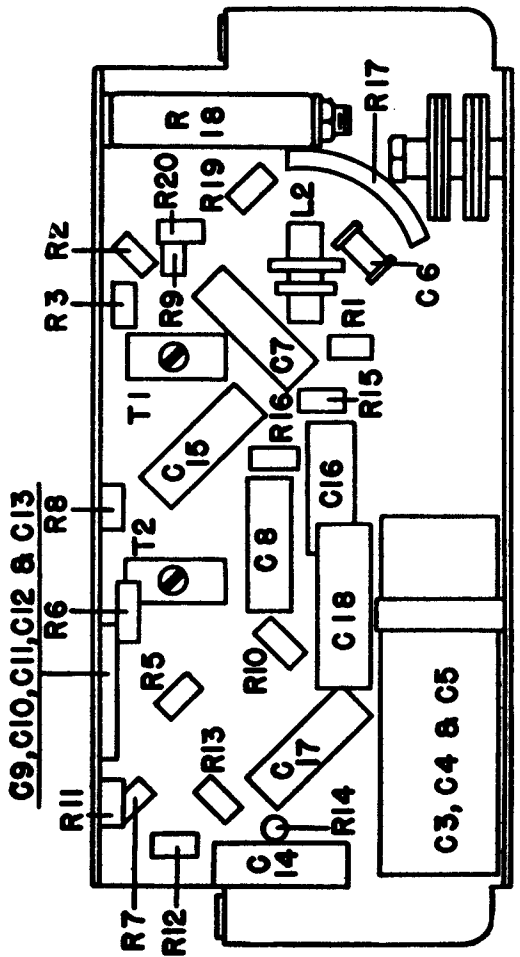

NOTES:
 VALUES OF CAPACITORS IN MFD. UNLESS SHOWN OTHERWISE.
 51, 51g - SWITCH ON VOLUME CONTROL.
 82A, 82g, 82d, 82e - AO/DC AND BATTERY SWITCH.
 ALL VOLTAGES MEASURED FROM COMMON NEGATIVE USING A 500 OHM IMPEDANCE. ALL VOLTAGES AT 117 V.A.C. VOLTAGE SHOULD BE AS SHOWN IN SET PER. 2-51.
 * THESE CAPACITORS ARE IN CERAMIC UNIT PART NUMBER.

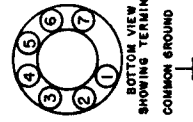

BOTTOM VIEW OF SOCKET SHOWING TERMINAL NUMBERING COMMON GROUND CHASSIS GROUND

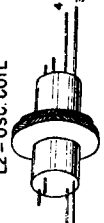

L2 - OSC. COIL

MANUAL OF 1951 MOST-OFTEN-NEEDED RADIO DIAGRAMS

Silvertone

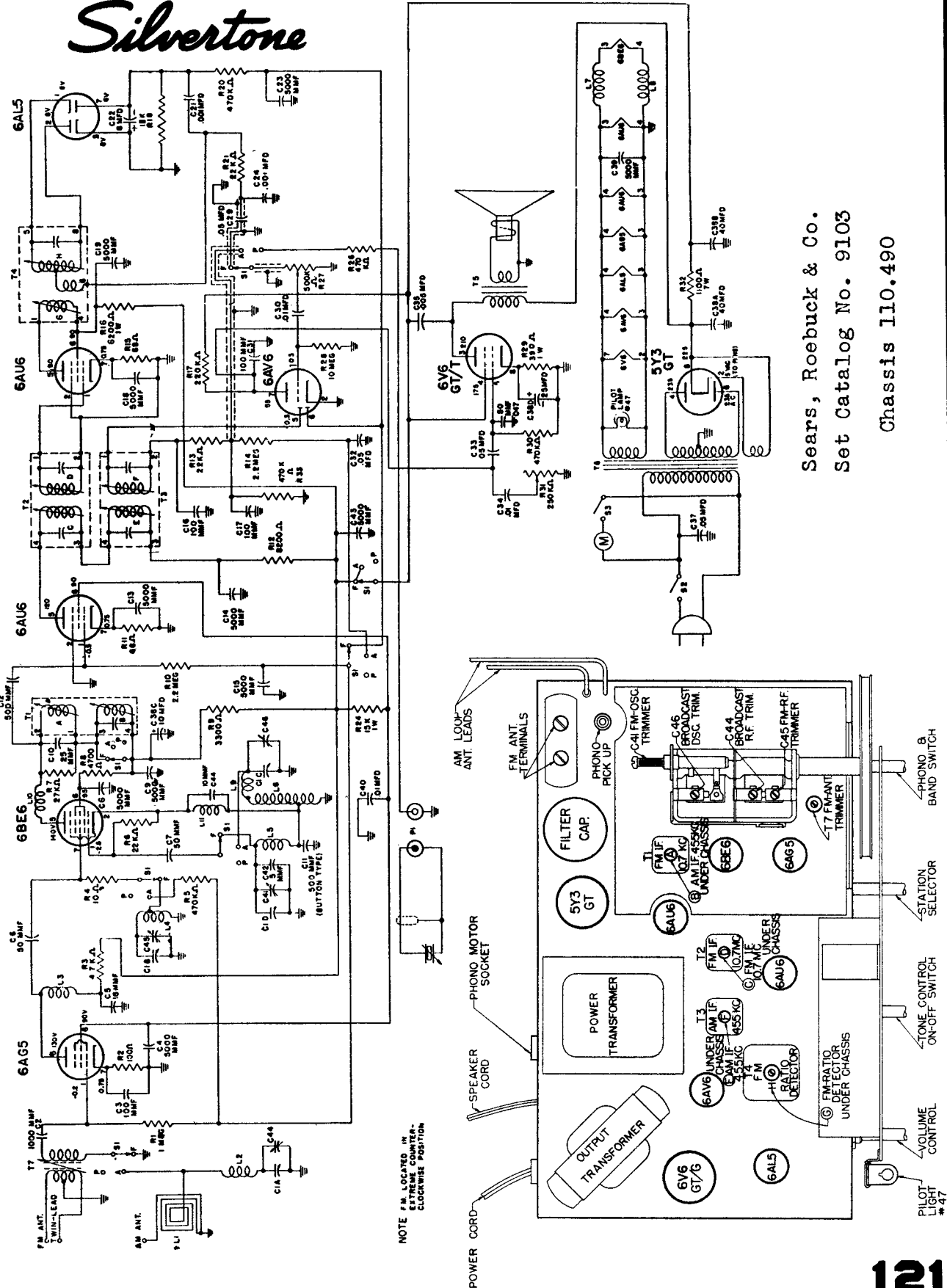

Sears, Roebuck & Co.
Set Catalog No. 9103
Chassis ILO.490

MANUAL OF 1951 MOST-OFTEN-NEEDED RADIO DIAGRAMS

Silvertone

Set Catalog No. 225

Chassis 528.171 and 528.171-1

5 TUBE BATTERY-AC-DC SUPERHETERODYNE PORTABLE RECEIVER
CATALOG No. 225

Silvertone

122

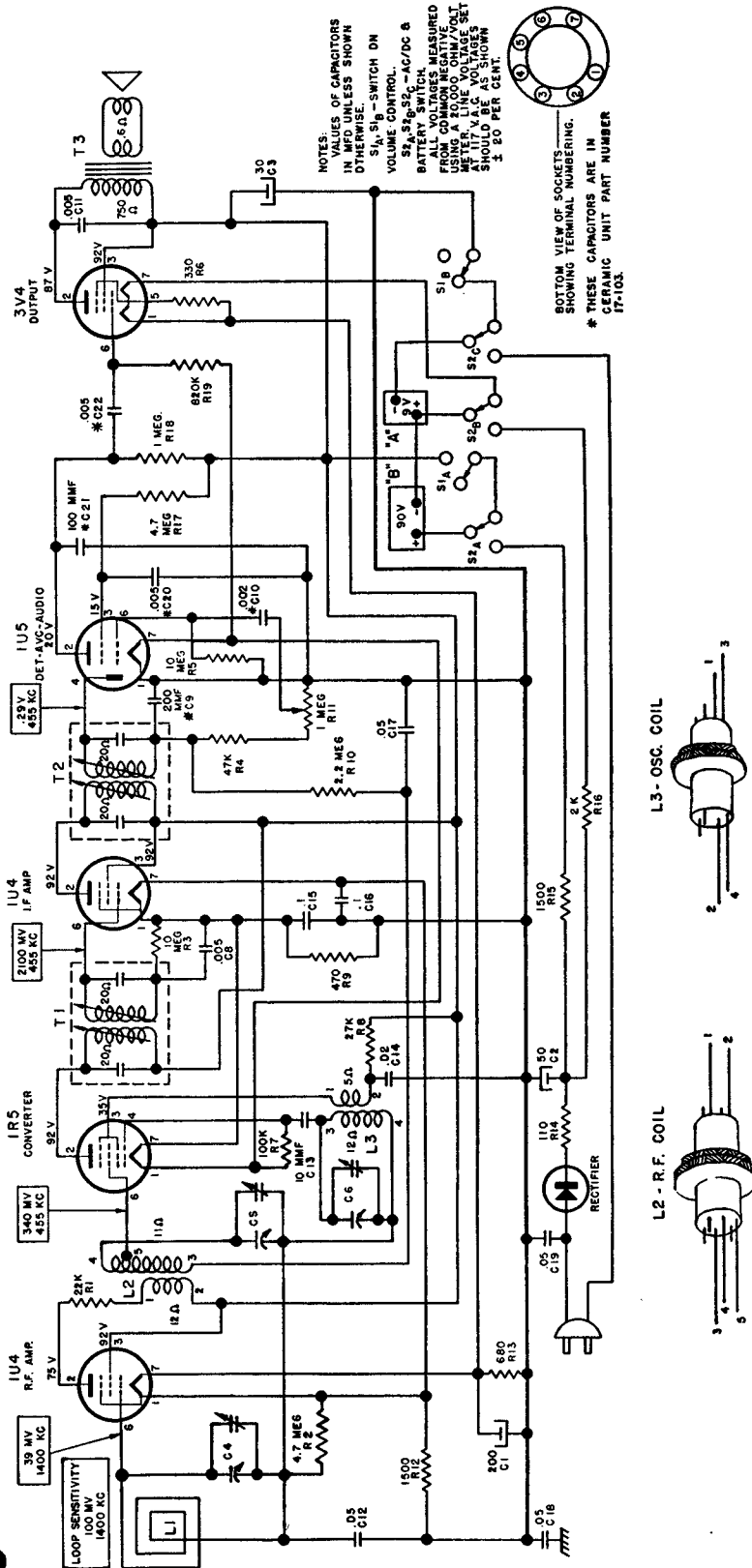

NOTES:
1. VALUES OF CAPACITORS IN MFD UNLESS SHOWN OTHERWISE.
2. S₁A, S₁B - SWITCH ON BATTERY CONTROL.
3. S₂A, S₂B, S₂C - AC/DC & BATTERY SWITCH.
4. ALL VOLTAGES MEASURED FROM COMMON POINT USING A 20,000 OHM/VOLT METER. LINE VOLTAGE SHOULD BE AS SHOWN ± 2.0 PER CENT.



BOTTOM VIEW OF SOCKETS SHOWING TERMINAL NUMBERING.
* THESE CAPACITORS ARE IN CERAMIC UNIT PART NUMBER 17-103.



SCHEMATIC DIAGRAM FOR SILVERTONE CHASSIS 528.171-1

Chassis 528.171-1 is the same as 528.171 except for the Battery/AC/DC changeover system. The hand-operated switch is replaced by a type which is operated by plugging the power cord into a chassis socket. The socket is near the back edge of the chassis. There is a slot for only one prong of the power cord plug; the other prong hangs over the back apron. The detachable power cord and the socket for it on the chassis are replaced by a conventional power cord.

MANUAL OF 1951 MOST-OFTEN-NEEDED RADIO DIAGRAMS

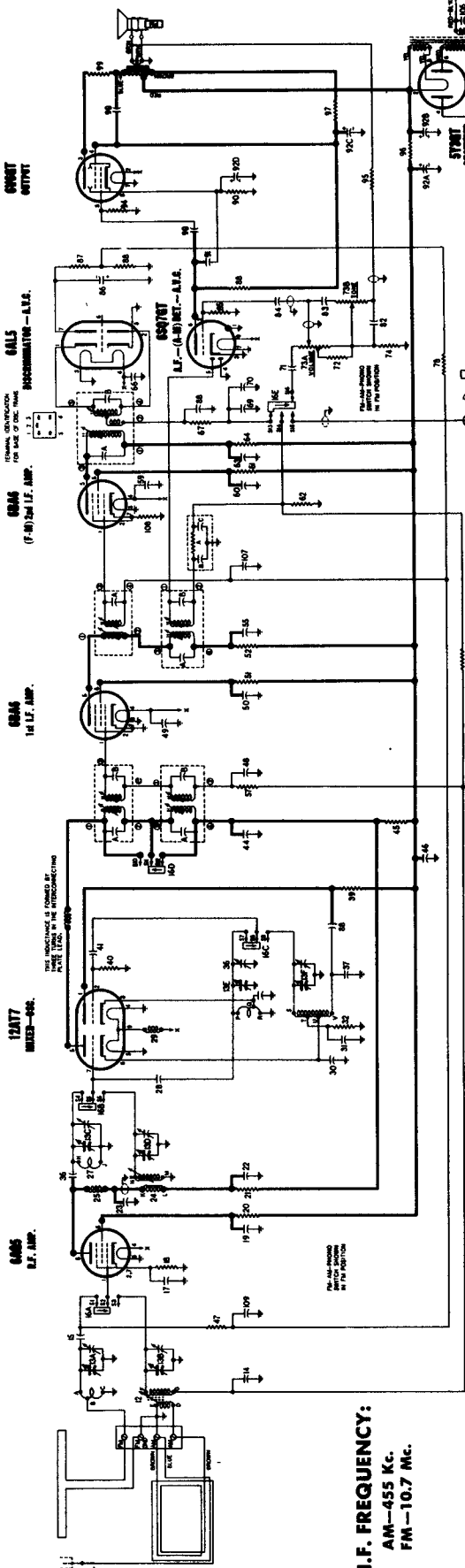

I.F. FREQUENCY:
 AM—455 Kc.
 FM—10.7 Mc.

CONDENSERS

- 13-A to F W506348 Condenser—variable gang (with drum).....
- 14.....W512027 Condenser—.05 Mfd. 200 volt.....
- 15.....W513406 Condenser—ceramic 22 Mmfd. 500 volt (Temperature compensating).....
- 17.....W513002 Condenser—ceramic 47 Mmfd. 500 volt.....
- 19.....W513013 Condenser—ceramic 5000 Mmfd. 450 volt.....
- 22.....W513013 Condenser—ceramic 5000 Mmfd. 450 volt.....
- 23.....W513002 Condenser—ceramic 47 Mmfd. 500 volt.....
- 26.....W513401 Condenser—ceramic 5 Mmfd. ± 10% 500 volt (Temperature compensating).....
- 28.....W513000 Condenser—ceramic 1.0 Mmfd. 500 volt.....
- 30.....W513007 Condenser—ceramic 330 Mmfd. 500 volt.....
- 31.....W512009 Condenser—.01 Mfd. 200 volt.....
- 35.....W513429 Condenser—ceramic 10 Mmfd. ± 10% 500 volt (Temperature compensating).....
- 36.....W506336 Condenser—trimmer; 3 to 30 Mmfd.....
- 37.....W513442 Condenser—ceramic 10 Mmfd. ± 10% 500 volt (Temperature compensating).....
- 38.....W513013 Condenser—ceramic 5000 Mmfd. 450 volt.....
- 41.....W513409 Condenser—ceramic 39 Mmfd. ± 5% 500 volt (Temperature compensating).....
- 44.....W513013 Condenser—ceramic 5000 Mmfd. 450 volt.....
- 46.....W513013 Condenser—ceramic 5000 Mmfd. 450 volt.....
- 48, 49, 50.....W513013 Condenser—ceramic 5000 Mmfd. 450 volt.....
- 55.....W513013 Condenser—ceramic 5000 Mmfd. 450 volt.....
- 59, 60.....W513013 Condenser—ceramic 5000 Mmfd. 450 volt.....
- 63.....W513013 Condenser—ceramic 5000 Mmfd. 450 volt.....
- 66.....W513013 Condenser—ceramic 5000 Mmfd. 450 volt.....
- 68.....W513007 Condenser—ceramic 330 Mmfd. 500 volt.....
- 69.....W512005 Condenser—.003 Mfd. 600 volt.....
- 70.....W513003 Condenser—ceramic 100 Mmfd. 500 volt.....

- 71.....W512027 Condenser—.05 Mfd. 200 volt.....
 - 82.....W512033 Condenser—.1 Mfd. 200 volt.....
 - 83.....W512001 Condenser—.001 Mfd. 600 volt.....
 - 84.....W512009 Condenser—.01 Mfd. 200 volt.....
 - 86.....W504937 Condenser—electrolytic 5 Mfd. 50 volt.....
 - 91.....W513008 Condenser—ceramic 470 Mmfd. 350 volt.....
 - 92-A,B,C,D,W505908 Condenser—electrolytic
 A—30 Mfd. 450 volt
 B—40 Mfd. 450 volt
 C—10 Mfd. 450 volt
 D—20 Mfd. 25 volt.....
 - 93.....W512009 Condenser—.01 Mfd. 200 volt.....
 - 98.....W512001 Condenser—.001 Mfd. 600 volt.....
 - 106.....W512256 Condenser—.01 Mfd. 600 volt.....
 - 107.....W513013 Condenser—ceramic 5000 Mmfd. 450 volt.....
 - 109.....W513013 Condenser—ceramic 5000 Mmfd. 450 volt.....
- ### RESISTORS
- 18.....W510117 Resistor—carbon 82 Ohms ± 10% ½ watt.....
 - 20.....W510164 Resistor—carbon 33,000 Ohms ½ watt.....
 - 21.....W510237 Resistor—carbon 1000 Ohms 1 watt.....
 - 32.....W510141 Resistor—carbon 1800 Ohms ± 10% ½ watt.....
 - 39.....W510249 Resistor—carbon 4700 Ohms 1 watt.....
 - 40.....W510155 Resistor—carbon 10,000 Ohms ½ watt.....
 - 45.....W510237 Resistor—carbon 1000 Ohms 1 watt.....
 - 47.....W510167 Resistor—carbon 47,000 Ohms ½ watt.....
 - 51.....W510165 Resistor—carbon 39,000 Ohms ± 10% ½ w.....
 - 52.....W510237 Resistor—carbon 1000 Ohms 1 watt.....
 - 56.....W510193 Resistor—carbon 2.2 Meg. ½ watt.....
 - 57.....W510173 Resistor—carbon 100,000 Ohms ½ watt.....
 - 61.....W510165 Resistor—carbon 39,000 Ohms ± 10% ½ w.....
 - 62.....W510185 Resistor—carbon 470,000 Ohms ½ watt.....

- 64.....W510237 Resistor—carbon 1000 Ohms 1 watt.....
- 67.....W510159 Resistor—carbon 18,000 Ohms ± 10% ½ w.....
- 72.....W510170 Resistor—carbon 69,000 Ohms ½ watt.....
- 73-A,B,C,W508483 Volume and tone control
 A—2 Meg.
 B—2 Meg.
 C—ON-Off; switch.....
- 74.....W510128 Resistor—carbon 330 Ohms ½ watt.....
- 78.....W510193 Resistor—carbon 2.2 Meg. ½ watt.....
- 85.....W510195 Resistor—carbon 4.7 Meg. ½ watt.....
- 87, 88.....W510153 Resistor—carbon 8200 Ohms ± 10% ½ watt.....
- 89.....W510179 Resistor—carbon 220,000 Ohms ½ watt.....
- 90.....W510128 Resistor—carbon 330 Ohms ½ watt.....
- 94.....W510185 Resistor—carbon 470,000 Ohms ½ watt.....
- 95.....W510148 Resistor—carbon 4700 Ohms ± 10% ½ watt.....
- 96.....W510732 Resistor—wire wound 2000 Ohms ± 10% 10 watts.....
- 97.....W510261 Resistor—carbon 22,000 Ohms 1 watt.....
- 99.....W510113 Resistor—carbon 47 Ohms ½ watt.....
- 108.....W510115 Resistor—carbon 68 Ohms ± 10% ½ watt.....

WIRING DIAGRAM

FOR SILVERTONE

CHASSIS 100.201

Catalog No. 69

ALIGNMENT PROCEDURE

STEP	SET RECEIVER DIAL TO	TEST OSCILLATOR		DUMMY ANTENNA	ADJUSTMENTS
		ADJUST TEST OSCILLATOR FREQUENCY TO	TEST OSCILLATOR ATTACH OUTPUT OF TEST OSCILLATOR TO		
1	Any point where no interfering signal is received.	EXACTLY 455 KC	High side to grid of 12AU6 Tube. Low side to common negative.	.05 MFD CONDENSER	Adjust slugs at top and bottom of 2nd I.F. (T2) and then each of the slugs of the 1st. I.F. for maximum output.
2	Exactly 1620 KC	Exactly 1620 KC.	External Antenna blue lead on loop.	100 MMFD Condenser.	Adjust 1620 KC oscillator trimmer (C4) for maximum output.
3	Approx. 1400 KC	A approx. 1400 KC	External Antenna blue lead on loop.	100 MMFD Condenser.	Adjust 1400 KC antenna trimmer for maximum output.

- C2, C7, C8 N-1345 Condenser, Paper .05 MFD. 200 V
- C6, C13 N-1344 Condenser, Paper .01 MFD. 400 V
- C9 N-8092 Condenser, Paper .08 MFD. 400 V
- C10 N-4015 Condenser, Ceramic 100 MMFD. 500 V. 20%.
- C11 N-4894 Condenser, Paper .005 MFD. 600V
- C12 N-6488 Condenser, Ceramic 250 MMFD. 500 V. 20%
- C14 N-1376 Condenser, Paper .02 MFD. 400 V
- C15) N-5051 Condenser, Dry Electrolytic (40 MFD. 150 V.)
- C16) N-5051 Condenser, Dry Electrolytic (40 MFD. 150 V.)
- C17 N-1346 Condenser, Paper .05 MFD. 400 V.
- R1 N-4062 Resistor, Carbon 3.3 Megohm 1/2W. 20%
- R2, R3 N-4063 Resistor, Carbon 47,000 Ohm 1/2W. 20%
- R4 N-1262 Resistor, Carbon 1.0 Megohm 1/2W. 20%
- R5 N-6485 Resistor, Carbon 68 Ohm 1/2W. 10%
- R6 N-7984 Volume Control 500,000 Ohm with Switch
- R7 N-4028 Resistor, Carbon 6.8 Megohm 1/2W. 20%
- R8 N-4026 Resistor, Carbon 220,000 Ohm 1/2W. 20%
- R9 N-4027 Resistor, Carbon 470,000 Ohm 1/2W. 20%
- R10 N-4067 Resistor, Carbon 180 Ohm 1/2W. 10%
- R11 N-3341 Resistor, Carbon 1,000 Ohm 1/2W. 10%
- L1 N-8002 Coll, Loop Antenna and Cabinet Back
- L2 N-7982 Coll, Oscillator
- T1, T2 N-7981 Coll, 1st. and 2nd. I.F. Transformer
- T3 N-8001 Transformer, Output
- N-7981 Speaker, 5 Inch P.M.
- N-8045 Assembly, Variable Gang Condenser & Pulley
- N-8005 Screen, Flocked Dial
- N-8004 Knobs, Walnut Plastic) For Model No.
- #315 Cabinet, Walnut Plastic) 607-315 Only
- N-8003 Knobs, Ivory Plastic) For Model No.
- #314 Cabinet, Ivory Plastic) 607-314 only
- N-7994 Pointer, Dial Indicator
- N-1090 Line Cord, 6 Foot Rubber
- N-8007

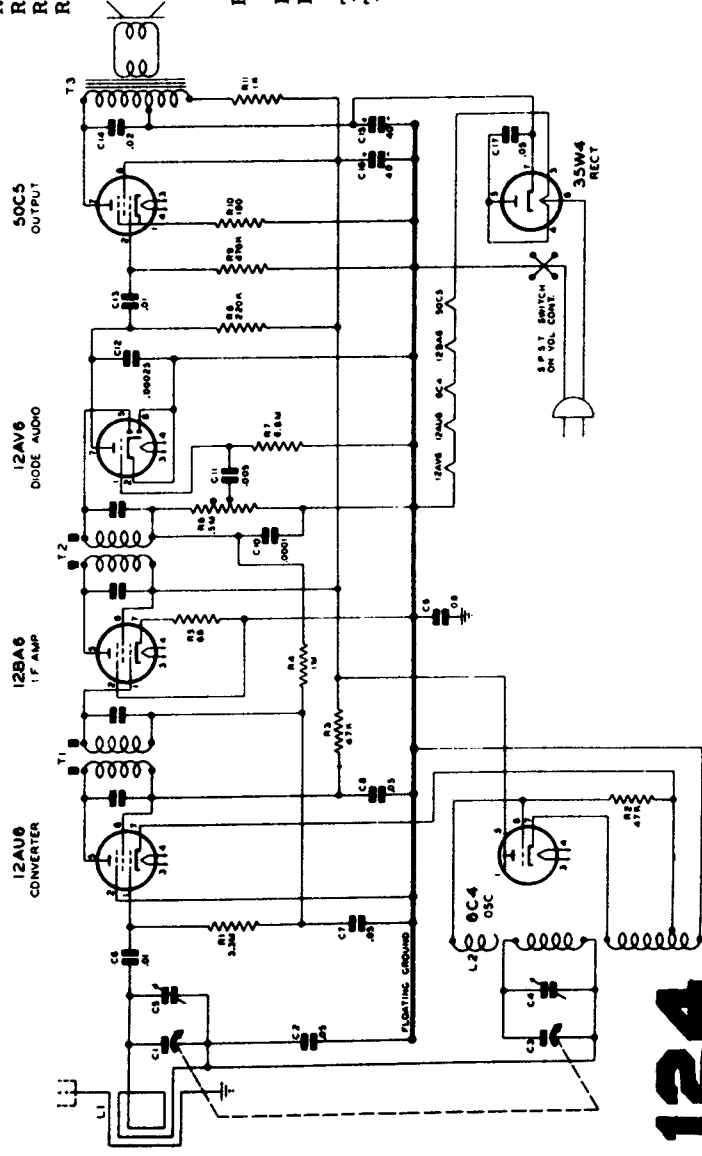

MANUAL OF 1951 MOST-OFTEN-NEEDED RADIO DIAGRAMS

Sonora Radio & Television Corp. Model 105

PART NO.	DESCRIPTION
1A	25000 OHM 5W 20% RESISTOR
1B	10000 OHM 5W 20% RESISTOR
1C	5000 OHM 5W 20% RESISTOR
1D	100 OHM 5W 20% RESISTOR
1E	100 OHM 1/2 10% RESISTOR
1F	100 OHM 1/2 10% RESISTOR
1G	100 OHM 1/2 10% RESISTOR
1H	100 OHM 1/2 10% RESISTOR
1I	100 OHM 1/2 10% RESISTOR
1J	100 OHM 1/2 10% RESISTOR
1K	100 OHM 1/2 10% RESISTOR
1L	100 OHM 1/2 10% RESISTOR
1M	100 OHM 1/2 10% RESISTOR
1N	100 OHM 1/2 10% RESISTOR
1O	100 OHM 1/2 10% RESISTOR
1P	100 OHM 1/2 10% RESISTOR
1Q	100 OHM 1/2 10% RESISTOR
1R	100 OHM 1/2 10% RESISTOR
1S	100 OHM 1/2 10% RESISTOR
1T	100 OHM 1/2 10% RESISTOR
1U	100 OHM 1/2 10% RESISTOR
1V	100 OHM 1/2 10% RESISTOR
1W	100 OHM 1/2 10% RESISTOR
1X	100 OHM 1/2 10% RESISTOR
1Y	100 OHM 1/2 10% RESISTOR
1Z	100 OHM 1/2 10% RESISTOR
2	50 MFD 350V CAPACITOR
3	2 MFD 500V CAPACITOR
4	100 MFD 50V CAPACITOR
5	100 MFD 50V CAPACITOR
6	100 MFD 50V CAPACITOR
7	100 MFD 50V CAPACITOR
8	100 MFD 50V CAPACITOR
9	100 MFD 50V CAPACITOR
10	100 MFD 50V CAPACITOR
11	100 MFD 50V CAPACITOR
12	100 MFD 50V CAPACITOR
13	100 MFD 50V CAPACITOR
14	100 MFD 50V CAPACITOR
15	100 MFD 50V CAPACITOR
16	100 MFD 50V CAPACITOR
17	100 MFD 50V CAPACITOR
18	100 MFD 50V CAPACITOR
19	100 MFD 50V CAPACITOR
20	100 MFD 50V CAPACITOR
21	100 MFD 50V CAPACITOR
22	100 MFD 50V CAPACITOR
23	100 MFD 50V CAPACITOR
24	100 MFD 50V CAPACITOR
25	100 MFD 50V CAPACITOR
26	100 MFD 50V CAPACITOR
27	100 MFD 50V CAPACITOR
28	100 MFD 50V CAPACITOR
29	100 MFD 50V CAPACITOR
30	100 MFD 50V CAPACITOR
31	100 MFD 50V CAPACITOR
32	100 MFD 50V CAPACITOR
33	100 MFD 50V CAPACITOR
34	100 MFD 50V CAPACITOR
35	100 MFD 50V CAPACITOR
36	100 MFD 50V CAPACITOR
37	100 MFD 50V CAPACITOR
38	100 MFD 50V CAPACITOR
39	100 MFD 50V CAPACITOR
40	100 MFD 50V CAPACITOR
41	100 MFD 50V CAPACITOR
42	100 MFD 50V CAPACITOR
43	100 MFD 50V CAPACITOR
44	100 MFD 50V CAPACITOR
45	100 MFD 50V CAPACITOR
46	100 MFD 50V CAPACITOR
47	100 MFD 50V CAPACITOR
48	100 MFD 50V CAPACITOR
49	100 MFD 50V CAPACITOR
50	100 MFD 50V CAPACITOR
51	100 MFD 50V CAPACITOR
52	100 MFD 50V CAPACITOR
53	100 MFD 50V CAPACITOR
54	100 MFD 50V CAPACITOR
55	100 MFD 50V CAPACITOR
56	100 MFD 50V CAPACITOR
57	100 MFD 50V CAPACITOR
58	100 MFD 50V CAPACITOR
59	100 MFD 50V CAPACITOR
60	100 MFD 50V CAPACITOR
61	100 MFD 50V CAPACITOR
62	100 MFD 50V CAPACITOR
63	100 MFD 50V CAPACITOR
64	100 MFD 50V CAPACITOR
65	100 MFD 50V CAPACITOR
66	100 MFD 50V CAPACITOR
67	100 MFD 50V CAPACITOR
68	100 MFD 50V CAPACITOR
69	100 MFD 50V CAPACITOR
70	100 MFD 50V CAPACITOR
71	100 MFD 50V CAPACITOR
72	100 MFD 50V CAPACITOR
73	100 MFD 50V CAPACITOR
74	100 MFD 50V CAPACITOR
75	100 MFD 50V CAPACITOR
76	100 MFD 50V CAPACITOR
77	100 MFD 50V CAPACITOR
78	100 MFD 50V CAPACITOR
79	100 MFD 50V CAPACITOR
80	100 MFD 50V CAPACITOR
81	100 MFD 50V CAPACITOR
82	100 MFD 50V CAPACITOR
83	100 MFD 50V CAPACITOR
84	100 MFD 50V CAPACITOR
85	100 MFD 50V CAPACITOR
86	100 MFD 50V CAPACITOR
87	100 MFD 50V CAPACITOR
88	100 MFD 50V CAPACITOR
89	100 MFD 50V CAPACITOR
90	100 MFD 50V CAPACITOR
91	100 MFD 50V CAPACITOR
92	100 MFD 50V CAPACITOR
93	100 MFD 50V CAPACITOR
94	100 MFD 50V CAPACITOR
95	100 MFD 50V CAPACITOR
96	100 MFD 50V CAPACITOR
97	100 MFD 50V CAPACITOR
98	100 MFD 50V CAPACITOR
99	100 MFD 50V CAPACITOR
100	100 MFD 50V CAPACITOR

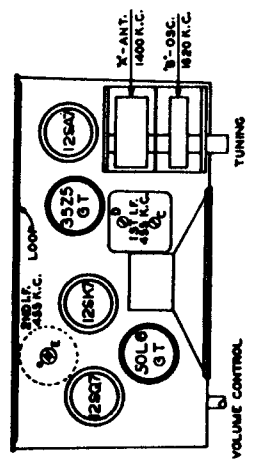
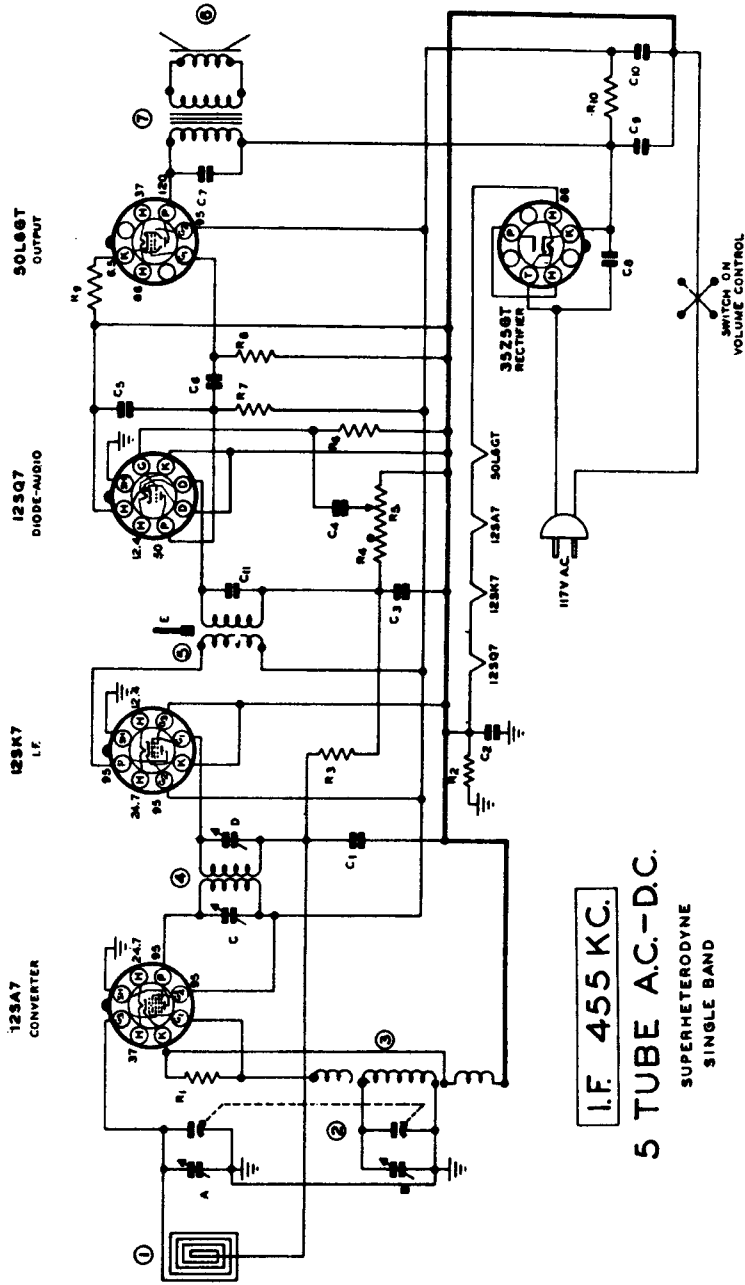

I.F. 455 KC.
5 TUBE A.C.-D.C.
SUPERHETERODYNE
SINGLE BAND

1951 MOST-OFTEN-NEEDED RADIO DIAGRAMS

SPARTON SUPERHETERODYNE CHASSIS TYPE 8M10

MODELS 141X, 142X
1040X, 1041X

Sparton Chassis 8W10, used in Models 141XX, 142XX, 1040XX, 1041XX, 1085, 1086, 1090, and 1091, electrically is almost identical to the chassis described on this page and on the next page (over).

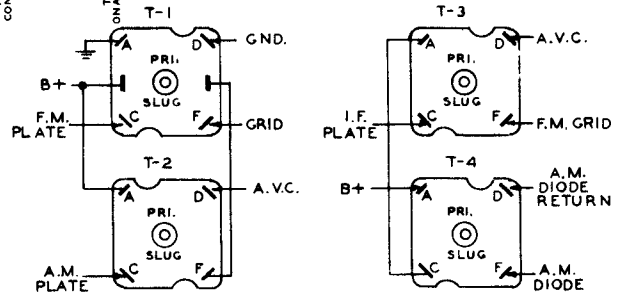
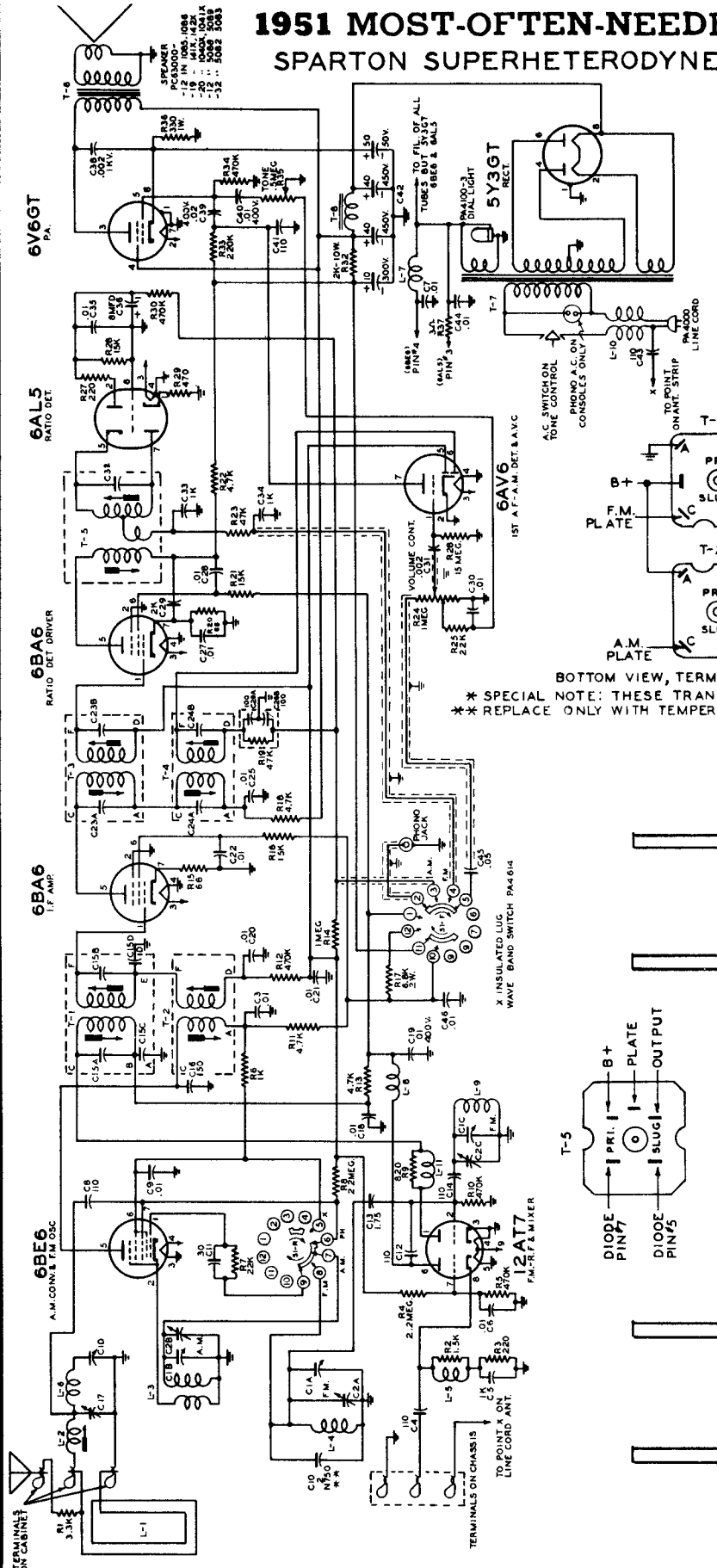

BOTTOM VIEW, TERMINAL HOOKUP FOR T-1, T-2, T-3, T-4 & T-5
* SPECIAL NOTE: THESE TRANSFORMERS SUPPLIED IN COMPLETE ASSEMBLIES
** REPLACE ONLY WITH TEMPERATURE COEFFICIENT AS INDICATED.

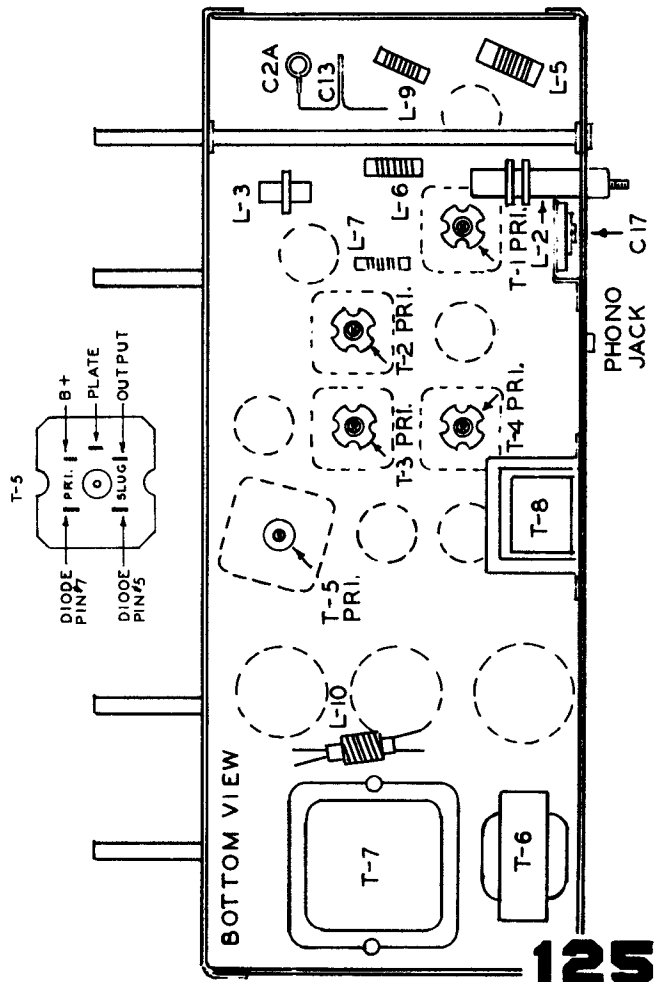

MANUAL OF 1951 MOST-OFTEN-NEEDED RADIO DIAGRAMS

SPARTON SUPERHETERODYNE RADIO RECEIVER CHASSIS TYPE 8M10 MODELS 141X, 142X, 1040X, 1041X

OPERATION	ALIGNMENT OF	GENERATOR CONNECTED TO	DUMMY ANT.	GENERATOR FREQUENCY	BAND SWITCH SETTING	TUNING COND SETTING	TRIMMER OR SLUG	REMARKS
1.	Set Dial pointer even with left-hand stop line with condenser gang closed.							
2.	Connect output meter across speaker terminals.							
3.	A.M.-I.F.	Pin #7 of 6BE6 Conv. Tube	.02 MFD Cond.	456 KC.	A.M.	Open	T4 Sec. Slug	Max. Reading
							T4 Pri. Slug	Max. Reading
							T2 Sec. Slug	Max. Reading
							T2 Pri. Slug	Max. Reading
4.	Repeat operation #3.							
5.		A.M. Ant.		1500 KC.		1500 KC.	C2B Osc. Tri.	Peak Accurately
6.	A.M.-R.F.	On Cabinet	*	1500 KC.	A.M.	1500 KC.	C17 Ant. Tri.	Peak Accurately
7.	A.M.-R.F.	On Cabinet	*	600 KC.	A.M.	600 KC.	L-2 Slug	Max. Reading
8.	Repeat operations #5, #6 and #7.							
9.	Check Calibrations at 600, 1000 and 1500 KC.							
10.	SPECIAL NOTE: For complete F.M.- I.F. Visual Alignment instructions please refer to pages 9.10.11.12.13 and 14 of Bulletin 11, Manual 6.							
11.	F.M.-I.F. Alignment using an A.M. Generator and Output Meter.							
12.	T5 F.M. Ratio Det.	Pin #1 of 2nd 6BA6 Tube	.02 MFD. Cond.	10.7 MC.	F.M.	Open	T5 Sec. Slug	Max. Reading
							T5 Pri. Slug	Max. Reading
13.	NOTE: Operations 11, 12, 14, 15, 18 and 19 must be made with generator output as low as possible, consistent with usable output meter reading.							
14.	T3 2nd. F.M.-I.F.	Pin #1 1st 6BA6 Tube	.02 MFD. COND.	10.7 MC.	F.M.	Open	T3 Sec. Slug	Max. Reading
							T3 Pri. Slug	Max. Reading
15.	T1 1st F.M.-I.F.	Pin #8 on 12AT7 Mixer Tube	.02 MFD. COND.	10.7 MC.	F.M.	Open	T1 Sec. Slug	Max. Reading
							T1 Pri. Slug	Max. Reading
16.	Adjust secondary slug on T5 ratio detector transformer to minimum deflection or dip on output meter. Under certain conditions it is possible to adjust T5 sec. slug to minimum noise with the receiver tuned to a weak station. This operation is very critical and the receiver must be tuned to the center response only.							
17.	F.M.-R.F. alignment using an A.M. Generator with frequencies of 88 to 108 MC. and a vacuum tube voltmeter or D. C. voltmeter. (20,000 Ohms per volt).							
18.	Place meter across C36 elect. condenser. (Meter reading approximately 1 volt)							
19.	F.M.-R.F.	F.M. Ant.	Match Gen. To 300 Ohms	106 MC	F.M.	106 MC.	C2A Osc. Tri.	Max. Reading
							C2C Ant. Tri.	Peak Accurately
20.	Check Calibration at 88 MC.							

*Use standard dummy antenna

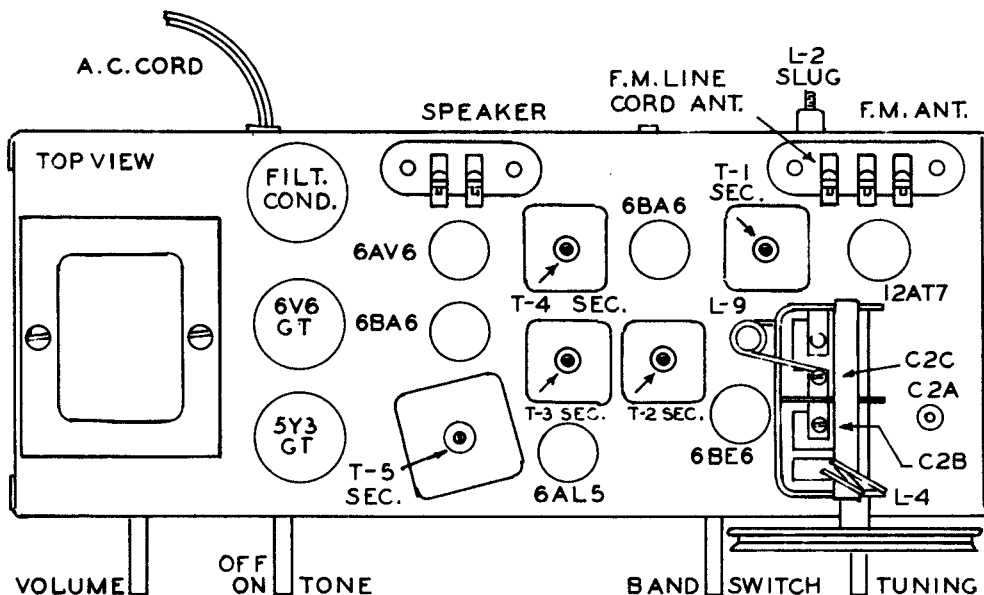

MANUAL OF 1951 MOST-OFTEN-NEEDED RADIO DIAGRAMS

STEWART-WARNER MODELS 9154-C & 9154-CZ

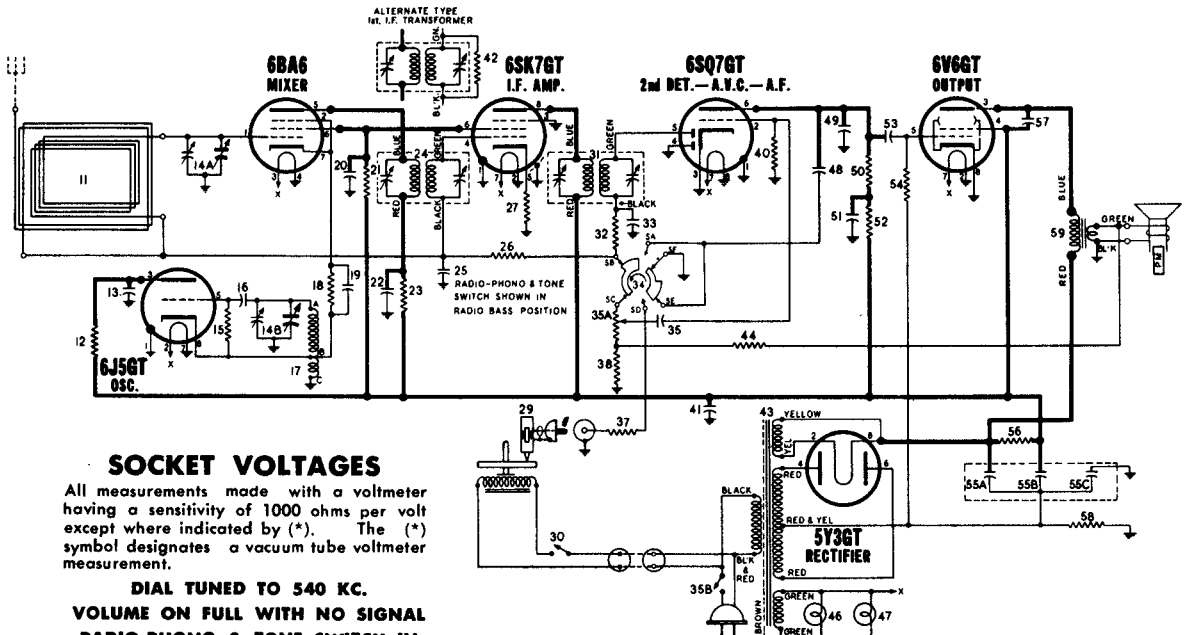

SOCKET VOLTAGES

All measurements made with a voltmeter having a sensitivity of 1000 ohms per volt except where indicated by (*). The (*) symbol designates a vacuum tube voltmeter measurement.

DIAL TUNED TO 540 KC.
VOLUME ON FULL WITH NO SIGNAL
RADIO-PHONO & TONE SWITCH IN
"RADIO-BASS" POSITION

I.F. 455 KC.

PARTS LIST

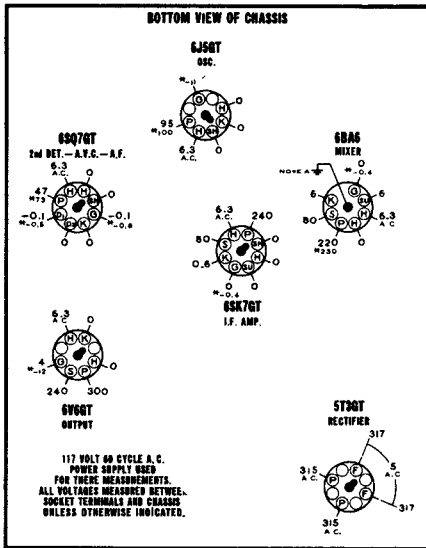

OSCILLATOR COIL 505326

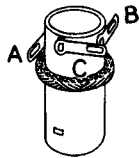

RADIO-PHONO & TONE SWITCH 505317

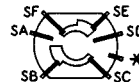

REAR VIEW

*Not used; may serve as wiring junction point.

Lettered terminals in illustrations correspond to similarly lettered terminals on the circuit diagram.

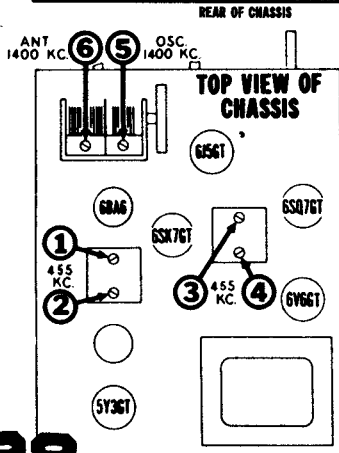

DIA-GRAM. NO.	PART NO.	DESCRIPTION
CONDENSERS		
13	512010	Condenser—.01 Mfd. 400 volt
14-A,B,	505315	Condenser—variable gong (with drum)
16	512503	Condenser—mica 100 Mmfd. 500 volt
19	512026	Condenser—.05 Mfd. 200 volt
20	512028	Condenser—.05 Mfd. 400 volt
22	512016	Condenser—.02 Mfd. 400 volt
25	512026	Condenser—.05 Mfd. 200 volt
33	512503	Condenser—mica 100 Mmfd. 500 volt.
36	512006	Condenser—.005 Mfd. 600 volt
41	512028	Condenser—.05 Mfd. 400 volt
48	512006	Condenser—.005 Mfd. 600 volt
49	512509	Condenser—mica 260 Mmfd. 500 volt
51	512034	Condenser—.1 Mfd. 400 volt.
53	512016	Condenser—.02 Mfd. 400 volt
55-A, B, C,	502207	Condenser—electrolytic A—20 Mfd.—400 volt B—10 Mfd.—400 volt C—20 Mds.—25 volt
57	512006	Condenser—.005 Mfd. 600 volt
RESISTORS		
12	510263	Resistor—carbon 33,000 Ohms ± 10% 1 watt
15	510167	Resistor—carbon 47,000 Ohms 1/2 watt
18	510143	Resistor—carbon 2,200 Ohms 1/2 watt
21	510267	Resistor—carbon 47,000 Ohms 1 watt
23	510152	Resistor—carbon 6,800 Ohms 1/2 watt
26	510194	Resistor—carbon 3.3 Meg. 1/2 watt
27	510112	Resistor—carbon 47 Ohms ± 10% 1/2 watt
32	510167	Resistor—carbon 47,000 Ohms 1/2 watt
35-A,B,	505318	Volume Control 1 Meg. (with switch)
37	510185	Resistor—carbon 470,000 Ohms 1/2 watt
38	510122	Resistor—carbon 150 Ohms 1/2 watt
40	510195	Resistor—carbon 4.7 Meg. 1/2 watt
42	510191	Resistor—carbon 1 Meg. 1/2 watt
44	510146	Resistor—carbon 3,300 Ohms 1/2 watt
50, 52	510179	Resistor—carbon 220,000 Ohms 1/2 watt
54	510185	Resistor—carbon 470,000 Ohms 1/2 watt
56	510346	Resistor—carbon 3,300 Ohms 2 watt
58	510707	Resistor—wire wound 200 Ohms ± 5% 2 watt

COILS AND TRANSFORMERS

11	505306	Loop antenna
17	505326	Coil—oscillator
24	502657	Transformer—1st I.F.
31	502658	Transformer—2nd I.F.
43	502174	Transformer—power
59	505305	Transformer—output

OTHER ELECTRICAL PARTS

29	509160	Pick-up cartridge
30	509205	Switch—"OFF-ON" for type VM-509032 record changer; used on Model 9154-C.
	520037	Switch—"OFF-ON" for type G1-509522 record changer; used on Model 9154-CZ
34	505317	Switch—radio-phono-tone
46, 47	110629	Lamp—dial (Moxdo #44) 6.3 v. 0.25 A

MANUAL OF 1951 MOST-OFTEN-NEEDED RADIO DIAGRAMS

STEWART-WARNER MODEL 9156-A

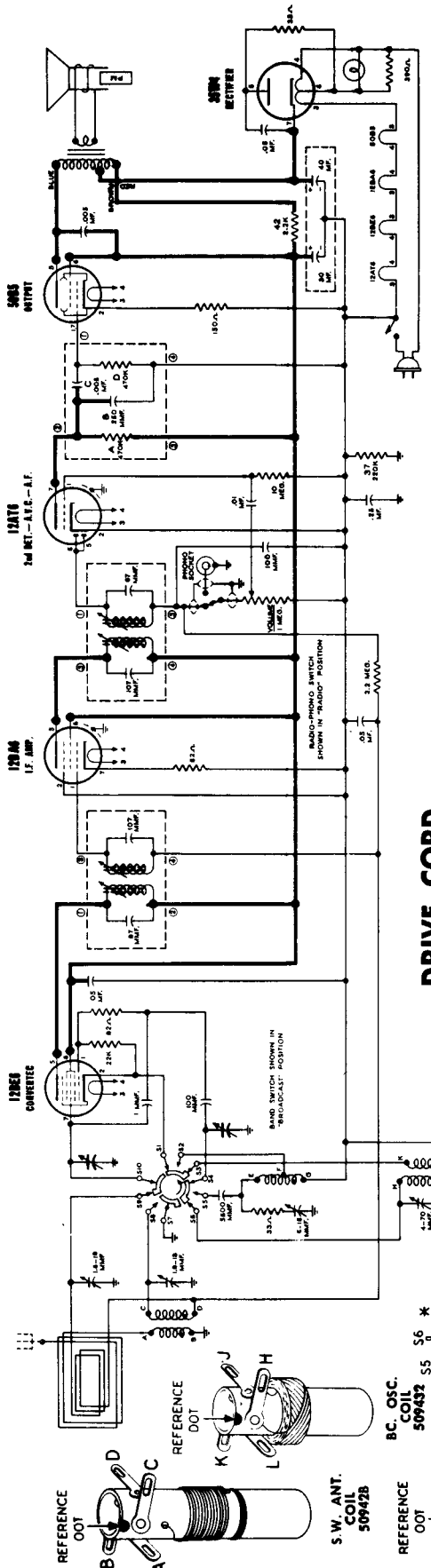

DRIVE CORD ARRANGEMENT

To string dial cord, turn the main drive drum to maximum position and use following parts:

- 114955 Clip on end of cord
- 502773 Cord (3½ feet)
- 119087 Ring
- 161384 Tension Spring

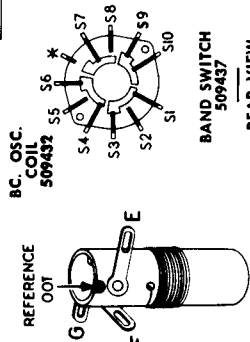
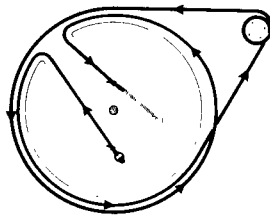

REAR VIEW
*Not used; may serve as wiring junction point.
Lettered terminals in illustrations correspond to similarly lettered terminals on the circuit diagram.

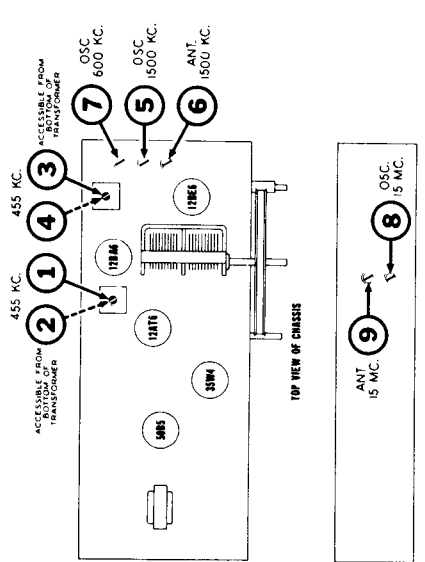

I.F. 455 KC.

SOCKET VOLTAGES

Measured with voltmeter having sensitivity of 20,000 ohms per volt except where indicated by (*). The (*) symbol designates a vacuum tube voltmeter measurement.

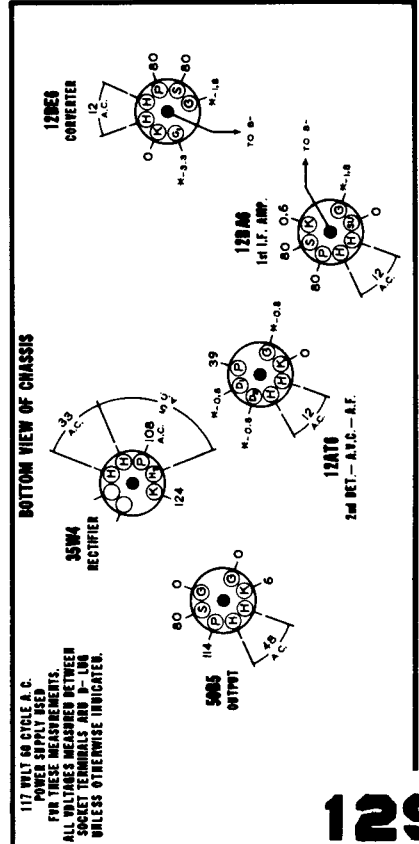

BAND SWITCH SET TO "SW" POSITION
DIAL TUNED TO MAXIMUM COUNTER-CLOCKWISE POSITION

BOTTOM VIEW OF CHASSIS

117 VOLT 60 CYCLE A.C. POWER SUPPLY USED FOR THESE MEASUREMENTS. ALL VOLTAGES MEASURED BETWEEN SOCKET TERMINALS AND B- LINE UNLESS OTHERWISE INDICATED.

MANUAL OF 1951 MOST-OFTEN-NEEDED RADIO DIAGRAMS

STROMBERG - CARLSON RADIO NO. 1507

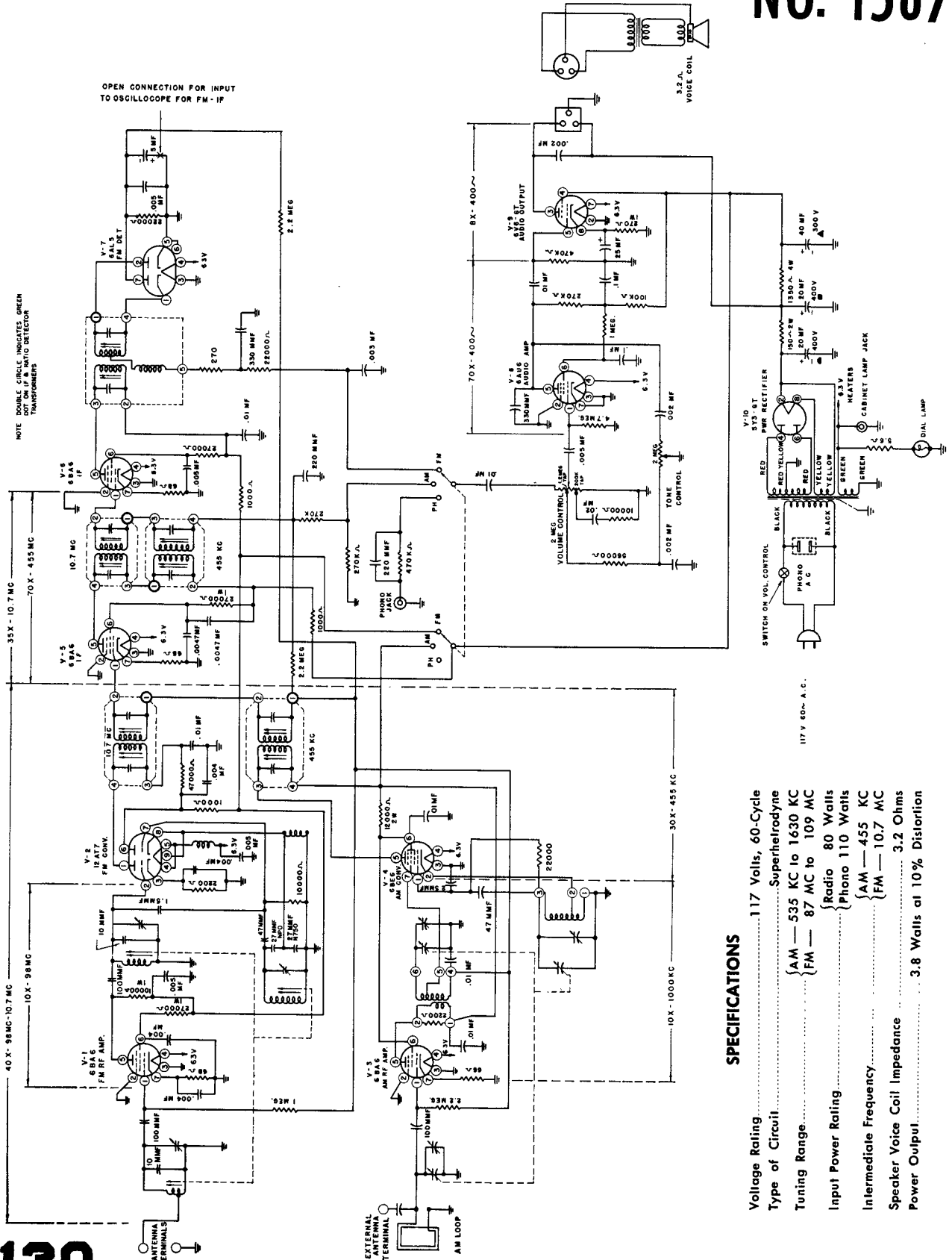

SPECIFICATIONS

- Voltage Rating..... 117 Volts, 60-Cycle
- Type of Circuit..... Superheterodyne
- Tuning Range..... { AM — 535 KC to 1630 KC
 { FM — 87 MC to 109 MC
- Input Power Rating..... { Radio 80 Watts
 { Phono 110 Watts
 { AM — 455 KC
 { FM — 10.7 MC
- Intermediate Frequency.....
- Speaker Voice Coil Impedance..... 3.2 Ohms
- Power Output..... 3.8 Watts at 10% Distortion

MANUAL OF 1951 MOST-OFTEN-NEEDED RADIO DIAGRAMS

STROMBERG - CARLSON

RADIO RECEIVER

NO. 1608

See next page, over, for additional service material.

No. 1608 SCHEMATIC DIAGRAM

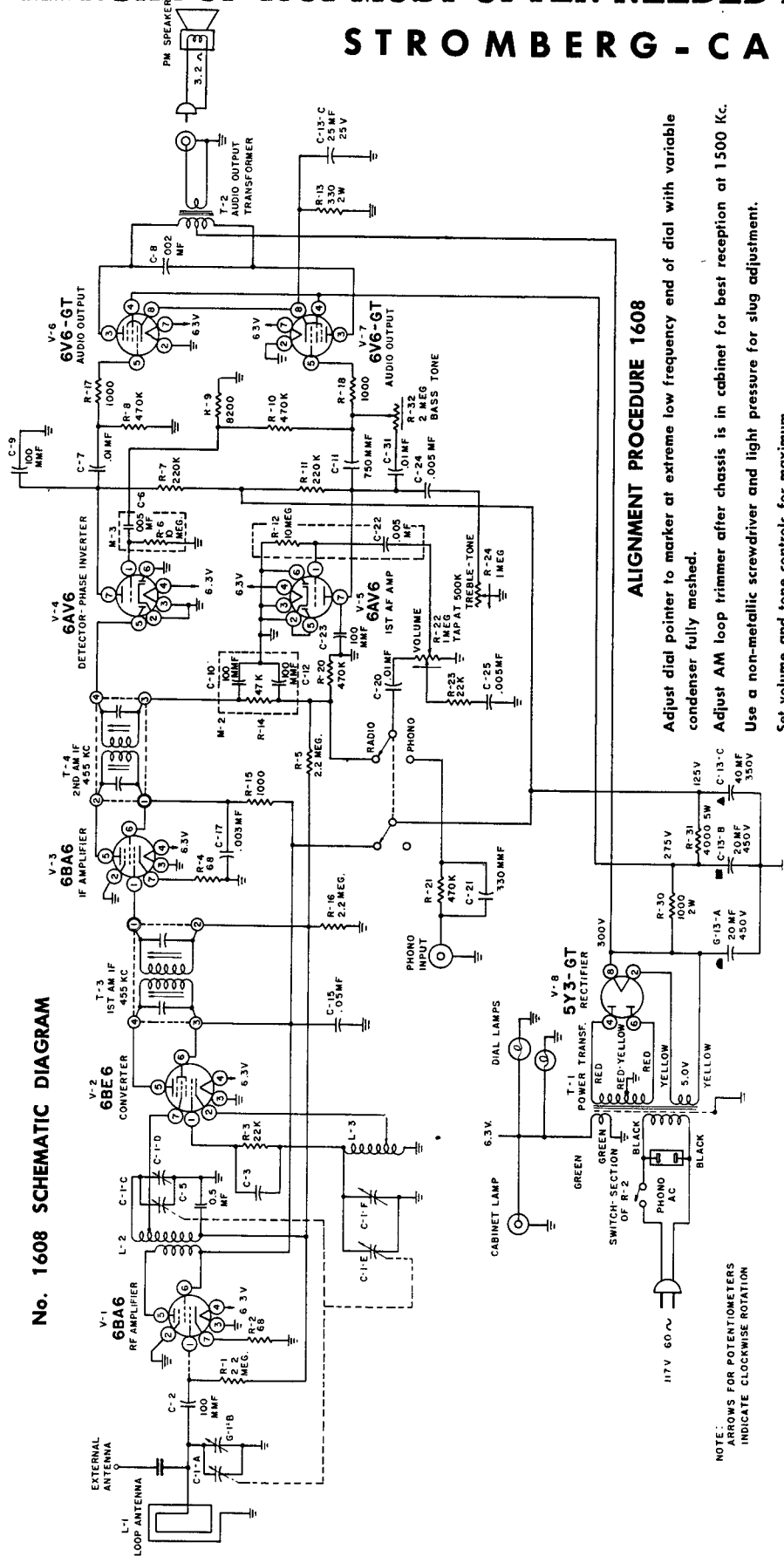

ALIGNMENT PROCEDURE 1608

- Adjust dial pointer to marker at extreme low frequency end of dial with variable condenser fully meshed.
- Adjust AM loop trimmer after chassis is in cabinet for best reception at 1500 Kc.
- Use a non-metallic screwdriver and light pressure for slug adjustment.
- Set volume and tone controls for maximum.

Pointer	Signal Generator	VTVM Connection	Adjustment and Notes
1. Pointer at 1000 Kc. approx.	455 Kc.-400 cy. modulation to grid of converter (pin 7 of V-2, 6BE6).	Terminal 2 of T-3.	Adjust top and bottom slugs of T-3 and T-4 for maximum output on VTVM.
2. Pointer at 1400 Kc.	1400 Kc.-400 cy. modulation to stator terminal of C-1-A.	Same as 1.	Adjust C-1-F and C-1-D for maximum output on VTVM.
3. Pointer at 1400 Kc.	1400 Kc.-400 cy. coupled through radiating loop.	Same as 1.	Readjust C-1-F, C-1-D, and C-1-B for maximum output on VTVM.

MANUAL OF 1951 MOST-OFTEN-NEEDED RADIO DIAGRAMS

STROMBERG - CARLSON RADIO NO. 1608

LOOKING AT INSIDE
BOTTOM OF CHASSIS.

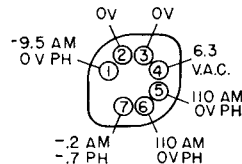
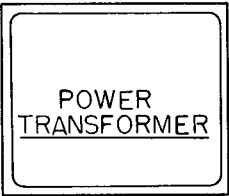
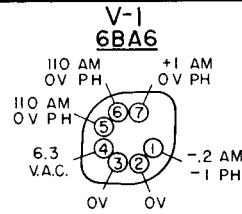

V-2
6BE6

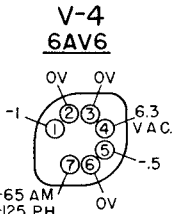

V-4
6AV6

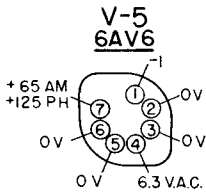

V-5
6AV6

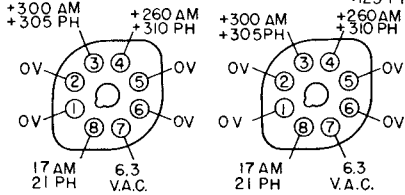

V-7 6V6 GT

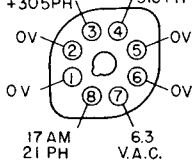

V-6 6V6 GT



REAR OF CHASSIS

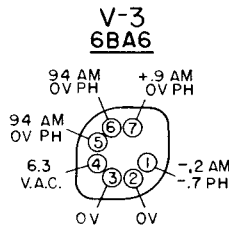

V-3
6BA6

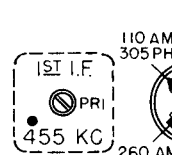

ELECTROLYTIC

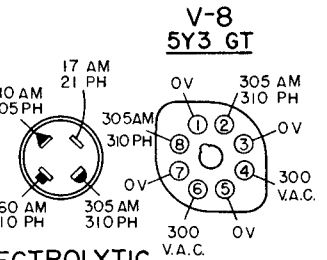

V-8
5Y3 GT

VOLTAGES MEASURED TO CHASSIS GROUND WITH VTVM TYPE METER.
DOTS ON I.F. TRANSFORMERS INDICATE THE POSITION OF COLOR CODED TERMINAL.

V-7
OUTPUT



V-6
OUTPUT

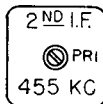

V-3
I.F.



V-8
RECT.



V-5
1ST A.F.



V-4
DET. &
PHASE INV.



V-2
CONV.



V-1
R.F.

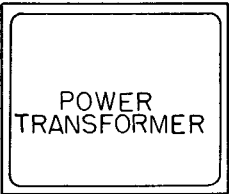

TOP VIEW OF CHASSIS
SHOWING TUBE LOCATION
AND TRIMMERS.

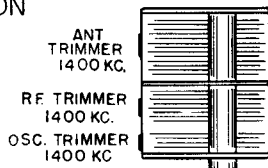

FRONT OF CHASSIS

MANUAL OF 1951 MOST-OFTEN-NEEDED RADIO DIAGRAMS

TRAV-LER RADIO CORP.

MODEL 5022

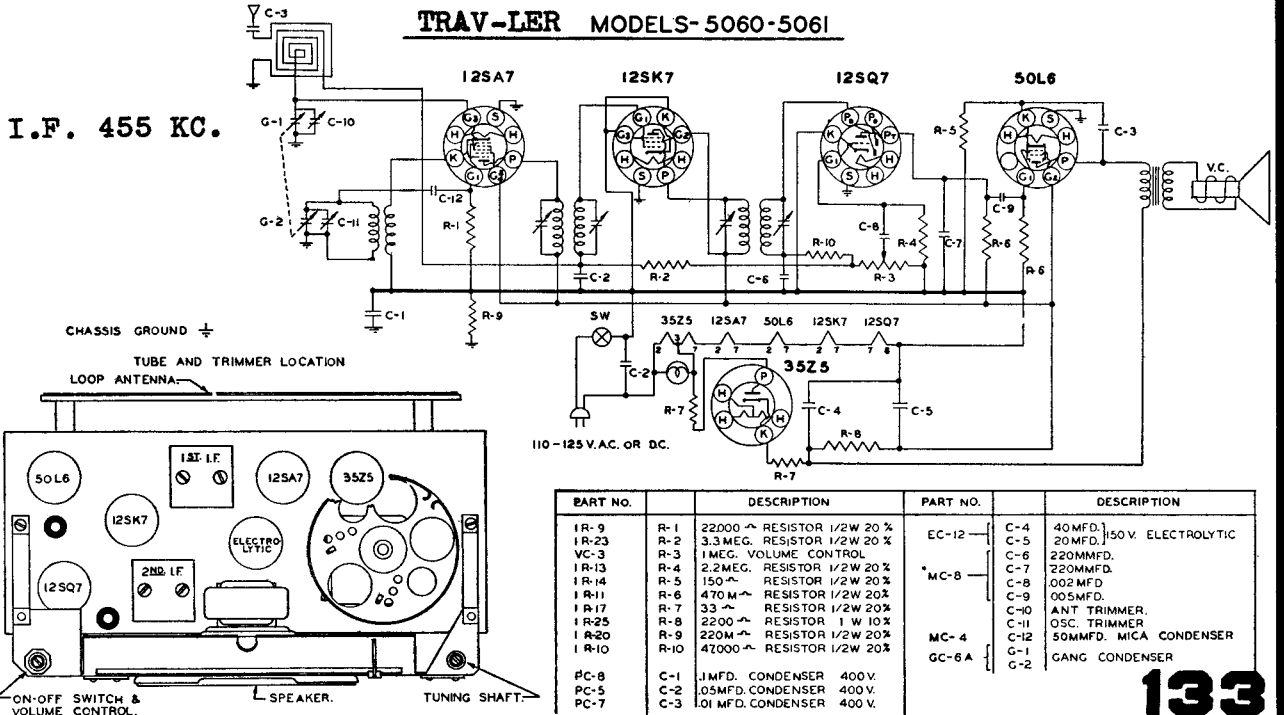
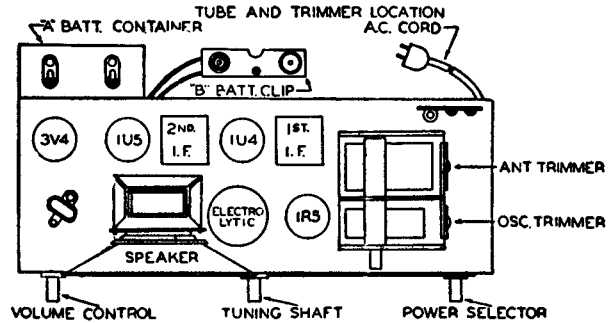
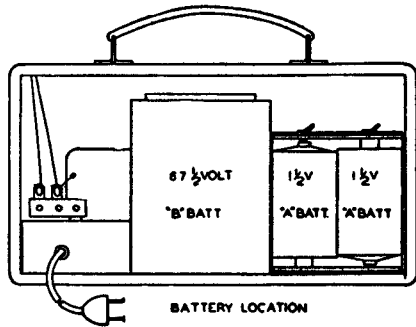
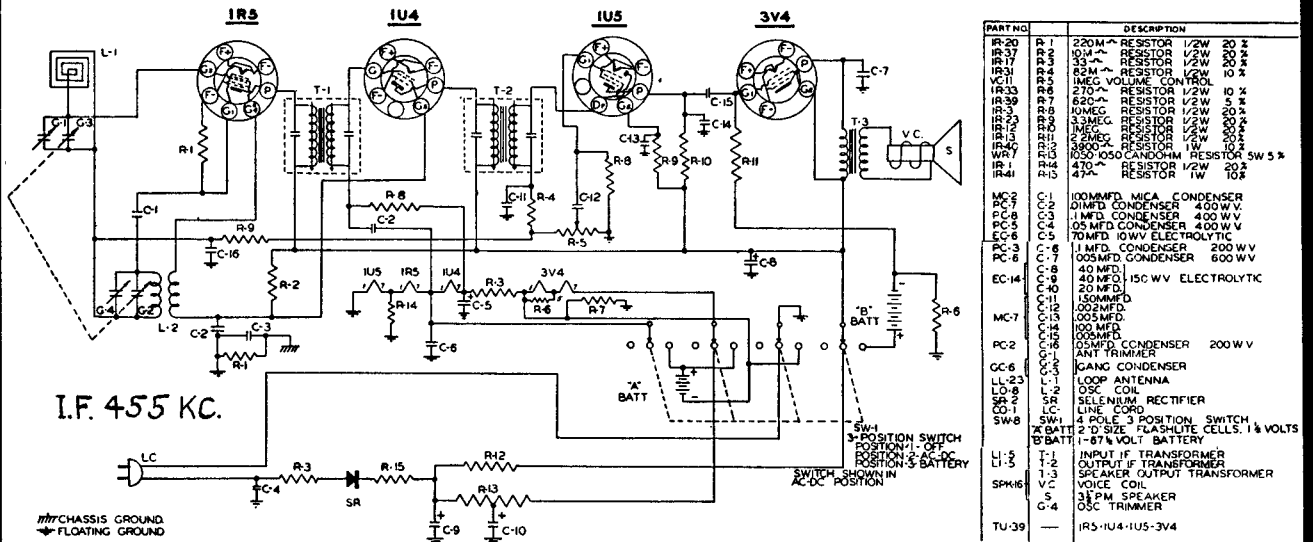

MANUAL OF 1951 MOST-OFTEN-NEEDED RADIO DIAGRAMS

TRAV-LER RADIO CORP.

MODEL 5066

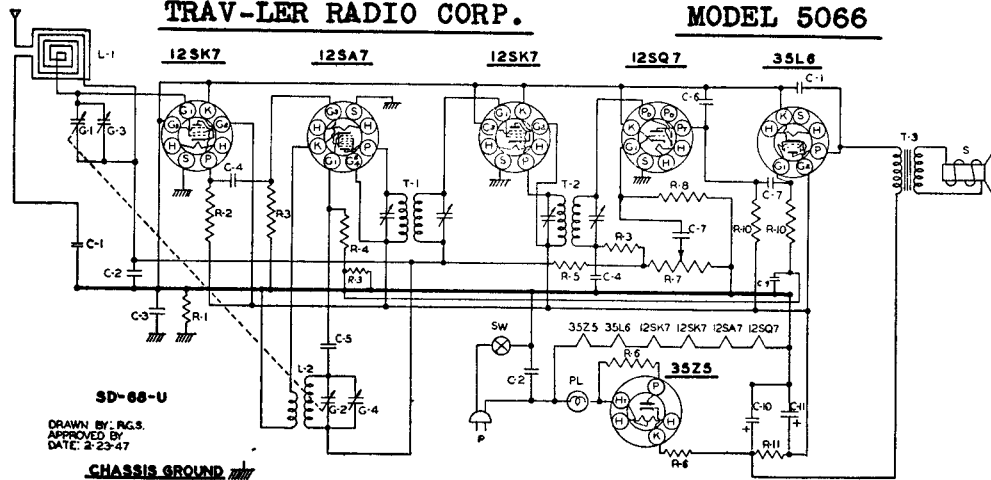

PART NO.	DESCRIPTION	PART NO.	DESCRIPTION	PART NO.	DESCRIPTION
PC-7	C-1 .01MFD. CONDENSER 400 V.	1R-9	R-4 22M Ω RESISTOR 1/2W 20%	LI-6	T-1 INPUT I.F. TRANSFORMER
PC-5	C-2 .05MFD. CONDENSER 400 V.	1R-23	R-5 3.3MEG Ω RESISTOR 1/2W 20%	LI-7	T-2 OUTPUT I.F. TRANSFORMER
PC-8	C-3 .1MFD. CONDENSER 400 V.	1R-17	R-6 33 Ω RESISTOR 1/2W 20%	SW	SWITCH ON VOLUME CONTROL
MC-2	C-4 .0001 MICA CONDENSER	VC-3	R-7 1MEG. VOLUME CONTROL	SPK-	T-3 OUTPUT TRANSFORMER
MC-4	C-5 .00005 MICA CONDENSER	1R-13	R-8 2.2MEG Ω RESISTOR 1/2W 20%	S	5" P.M. SPEAKER
MC-5	C-6 .0005 MICA CONDENSER	1R-11	R-9 470M Ω RESISTOR 1/2W 20%	PB-1	PL #47 PILOT BULB
PC-8	C-7 .005MFD. CONDENSER 600 V.	1R-25	R-11 2200 Ω RESISTOR 1 W 10%	CO-1	P LINE CORD
PC-4	C-9 .25MFD. COND. 200 V.				
EC-12	C-10 .40MFD. ELECTROLYTIC. 150 W.V.	GC-5	G-1 GANG CONDENSER		
	C-11 .20MFD.		G-2		
1R-20	R-1 220M Ω RESISTOR 1/2W 20%		G-3		
1R-22	R-2 3900 Ω RESISTOR 1/2W 10%	LL-16	L-1 LOOP ANT.		
1R-10	R-3 47M Ω RESISTOR 1/2W 20%	LD-10	L-2 OSC. COIL.		

ALIGNMENT

Remove chassis from cabinet for alignment.

A Signal Generator is required having the following frequencies: 455 KC, 1400 KC, 1720 KC. An output meter should be connected across the speaker.

The receiver volume control should be turned to maximum during the I.F. and all subsequent alignments to keep the AVC from working and giving false readings. Keep the generator output as low as possible to prevent overloading.

FIRST STEP: Connect the hot lead from the generator to the ANT. section of the gang condenser, through a .1 MFD condenser. The ground lead from the generator must be connected to the floating ground buss under the chassis. Turn the gang condenser to complete minimum capacity. Adjust the generator to 455KC and adjust the trimmers of the 1st and 2nd I.F. transformers until a maximum reading is noted on the output meter.

SECOND STEP: With the leads from the generator still connected in the same manner, adjust the Signal Generator to 1720 KC. The OSC. trimmer is located on the front of the chassis. Adjust this trimmer until the 1720 KC signal is tuned in.

THIRD STEP: Remove the hot lead of the generator from the ANT section of the gang condenser. Connect this lead to the primary of the loop antenna through a 200 MMFD condenser. Adjust the Signal Generator to 1400 KC. Rotate the tuning control until this signal is tuned in. The ANT trimmer is located on the back of the loop antenna. Adjust this trimmer until a maximum reading is noted on the output meter. No further adjustment should be necessary, unless the set has been damaged, as the coils and condenser in this receiver have been specially handled at the factory to insure proper alignment at the lower frequencies.

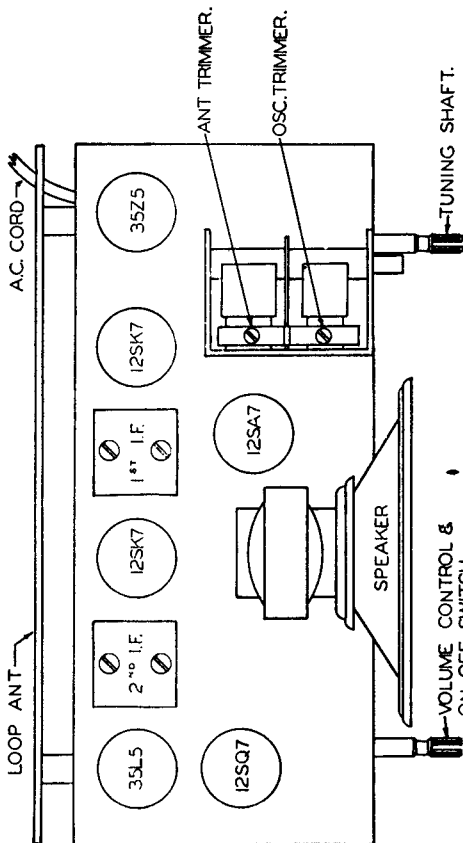

MANUAL OF 1951 MOST-OFTEN-NEEDED RADIO DIAGRAMS

UNITED MOTORS

Cadillac 7260405
7260905

MOUNTING—Model 7260405 - All 1951
Cadillac Sedans. Model 7260905 - All
1951 Cadillac Convertibles.

Packard Model 416394
uses a similar circuit.

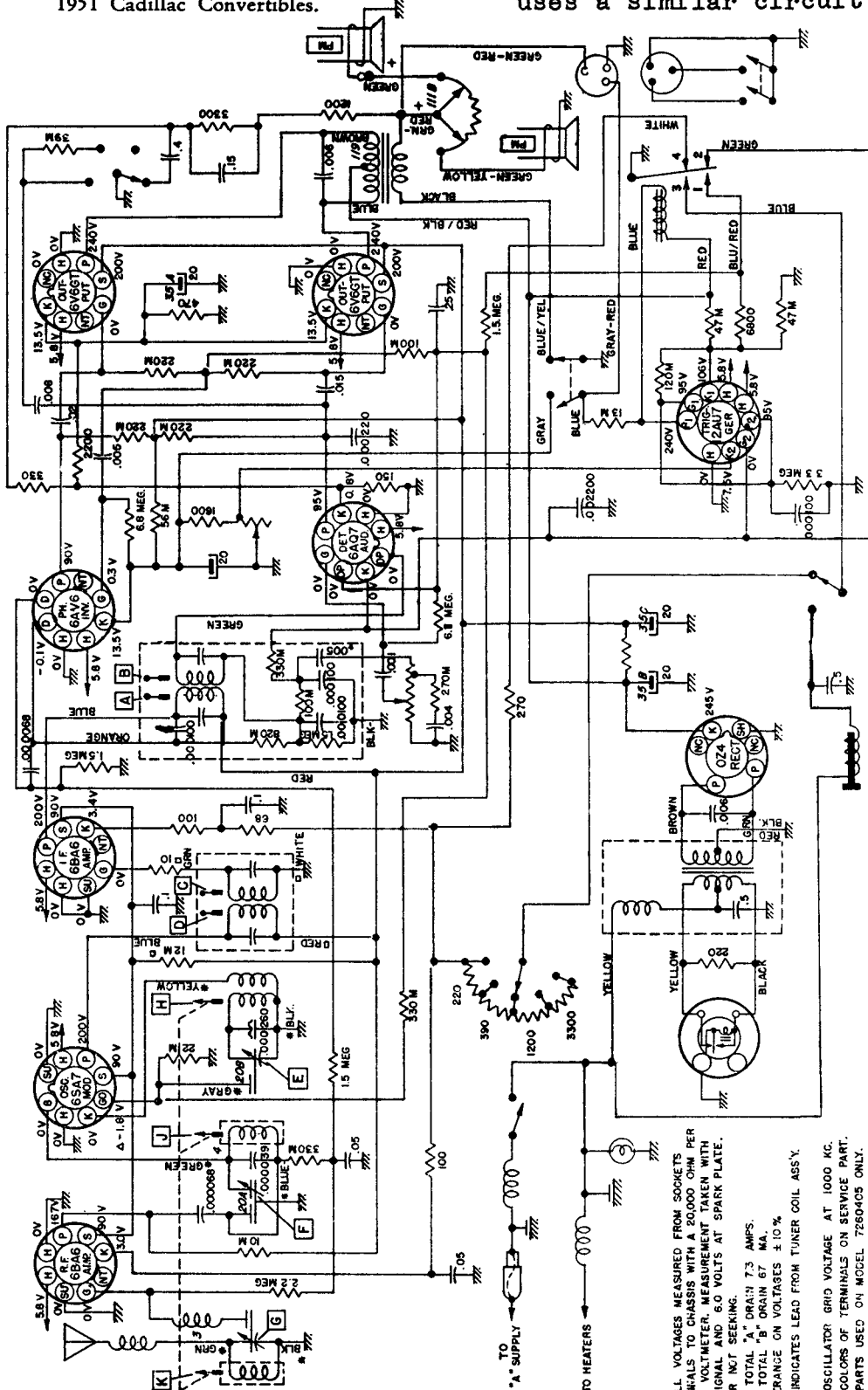

Output Meter VTVM From [2] To Chassis
Generator Return Receiver Chassis
Dummy Antenna In Series With Generator
Volume Control Maximum Volume
Sensitivity Control Maximum Sensitivity
Tone Control Treble
Generator Output Not To Exceed 2 Volts

Step	Dummy Antenna	Connect To	Signal Generator Frequency	Tune Receiver To	Adjust in Sequence for Max. Output
1	0.1 mfd	6SA7 Grid (Pin 8)	260 KC	*High Frequency Stop	A, B, C, D
2	0.000068 mfd	Antenna Connector	1615 KC	High Frequency Stop	E, F, G
3	0.000068 mfd	Antenna Connector	600 KC	Signal Gen. Signal	J, K
4	0.000068 mfd	Antenna Connector	1615 KC	Signal Gen. Signal	F, G
5	0.000068 mfd	Antenna Connector	1000 KC	Signal Gen. Signal	L

*To tune to high frequency, put a 0.070" feeler gauge (or bare #13 wire) in slot against the high frequency stop.

ALL VOLTAGES MEASURED FROM SOCKETS
TERMINALS TO CHASSIS WITH A 20,000 OHM PER
VOLT VOLTMETER. MEASUREMENT TAKEN WITH
NO SIGNAL AND 6.0 VOLTS AT SPARK PLATE.
TUNER NOT SEEKING.
TOTAL "A" DRAIN 7.3 AMPS.
TOTAL "B" DRAIN 67 MA.
TOLERANCE ON VOLTAGES ± 10 %
* - INDICATES LEAD FROM TUNER COIL ASS'Y.
Δ - OSCILLATOR GRID VOLTAGE AT 1000 KC.
□ - COLORS OF TERMINALS ON SERVICE PART.
+ - PARTS USED ON MODEL 7260405 ONLY.

MANUAL OF 1951 MOST-OFTEN-NEEDED RADIO DIAGRAMS

UNITED MOTORS

Oldsmobile 982697
982698

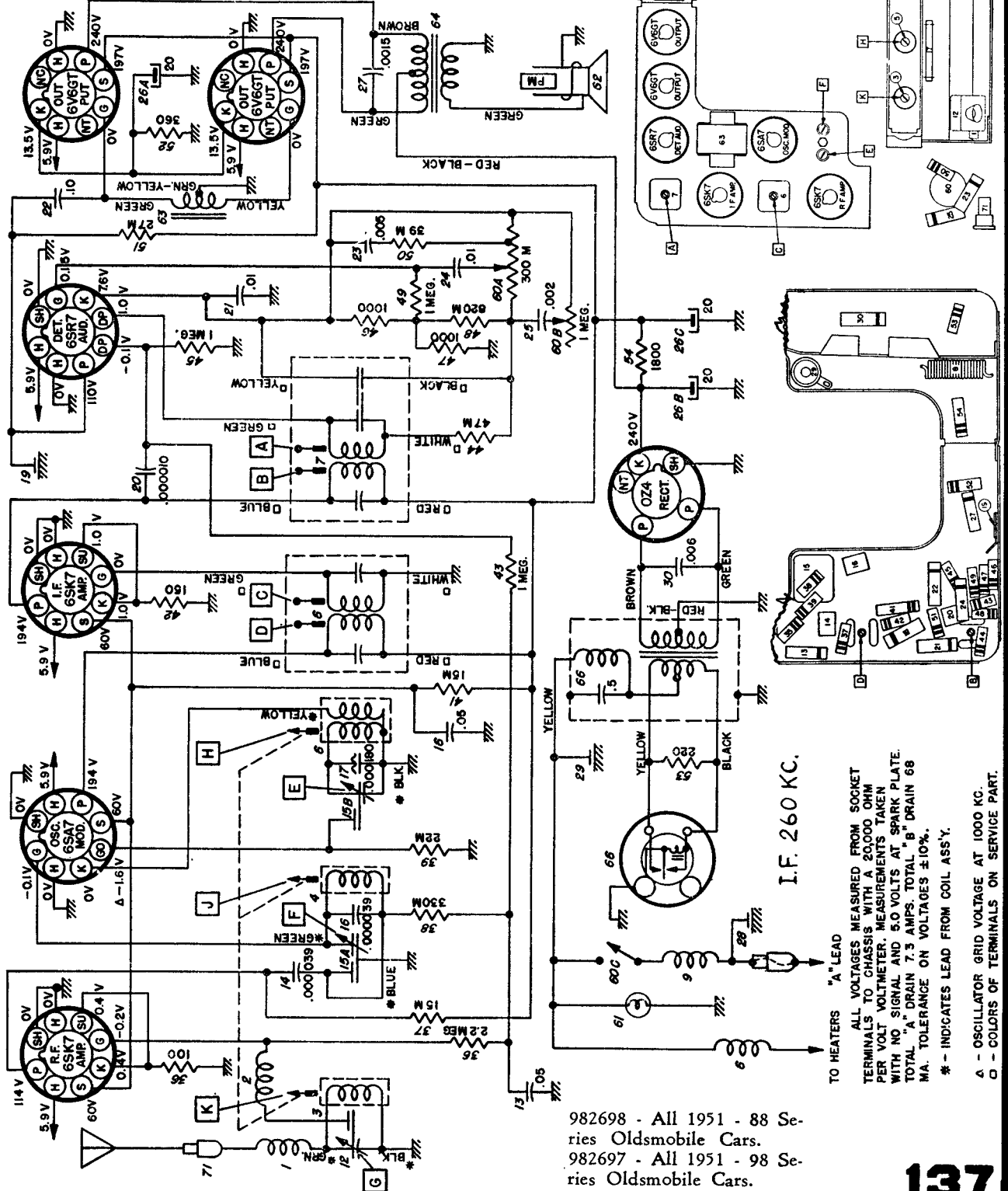

982698 - All 1951 - 88 Series Oldsmobile Cars.
982697 - All 1951 - 98 Series Oldsmobile Cars.

MANUAL OF 1951 MOST-OFTEN-NEEDED RADIO DIAGRAMS

UNITED MOTORS

Chevrolet 986515

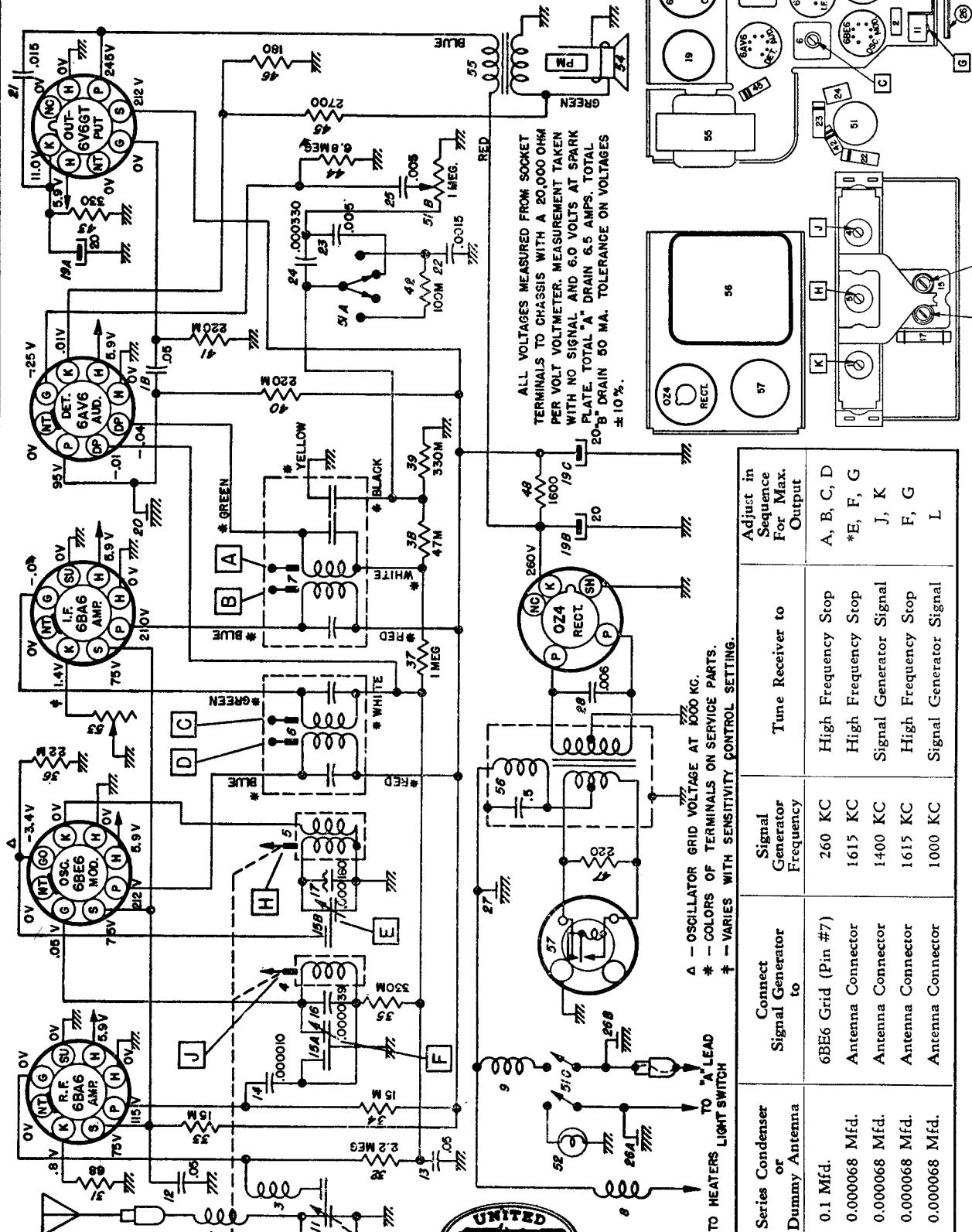

140



TO HEATERS LIGHT SWITCH
TO "A" LEAD
TO HEATERS LIGHT SWITCH

Steps	Series Condenser or Dummy Antenna	Connect Signal Generator to	Signal Generator Frequency	Tune Receiver to	Adjust in Sequence For Max. Output
1	0.1 Mfd.	6BE6 Grid (Pin #7)	260 KC	High Frequency Stop	A, B, C, D
2	0.000068 Mfd.	Antenna Connector	1615 KC	High Frequency Stop	*E, F, G
3	0.000068 Mfd.	Antenna Connector	1400 KC	Signal Generator Signal	J, K
4	0.000068 Mfd.	Antenna Connector	1615 KC	High Frequency Stop	F, G
5	0.000068 Mfd.	Antenna Connector	1000 KC	Signal Generator Signal	L

*Before making this adjustment check mechanical setting of oscillator core "H." The rear of the core should be 1.25/32" from the mounting end of the coil form.

MANUAL OF 1951 MOST-OFTEN-NEEDED RADIO DIAGRAMS

Western Auto Supply Co.

tru-tone

REG. U.S. PAT. OFF.

MODEL D2017 (WALNUT)
FACTORY MODEL 25D26-006

MODEL D2018 (IVORY)
FACTORY MODEL 225D26-002

These models with a suffix "A" had another 1500-ohm resistor wired in parallel with R-13, and had the rectifier tube 35W4 wired as shown in the partial schematic, below. In models with a suffix "B" a single 750-ohm resistor was used for R-13, and the 35W4 was wired as shown.

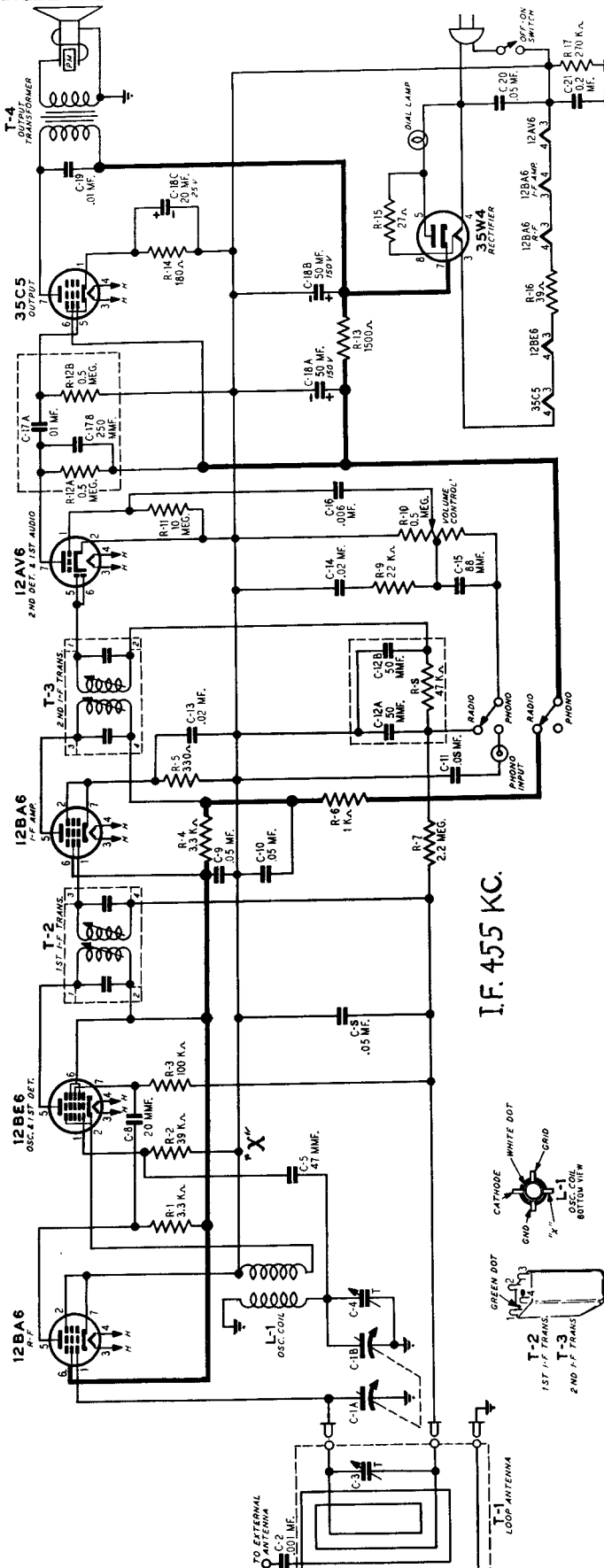
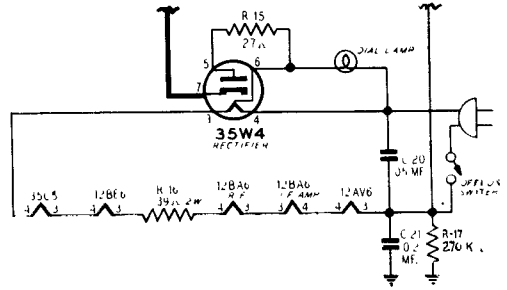

I.F. 455 KC.

TUBE SOCKET VOLTAGES

Socket voltages are shown on the Bottom Socket diagram at the tube socket terminals. All voltages are between the socket terminal and chassis ground. Plate, screen and cathode voltages were taken with a 1000 ohm-per-volt meter with a 300 volt scale used for plate and screen voltages. Audio grid voltages were read with a vacuum tube volt-meter.

Line voltage117 Volts AC
Signal InputNone
A Variation of $\pm 10\%$ is usually permissible.

12BE6
OSC. & 1ST DET.
G3: 1.5V
G2: 50V
G1: 0.5V
H: 0.5V

12BA6
I-F AMP.
G3: 1.5V
G2: 50V
G1: 0.5V
H: 0.5V

12AV6
2ND DET. & 1ST AUDIO
G3: 1.5V
G2: 50V
G1: 0.5V
H: 0.5V

35C5
OUTPUT
K: 180V
G1: 0.5V
G2: 50V
G3: 1.5V
H: 0.5V

35W4
RECTIFIER
K: 180V
G1: 0.5V
G2: 50V
G3: 1.5V
H: 0.5V

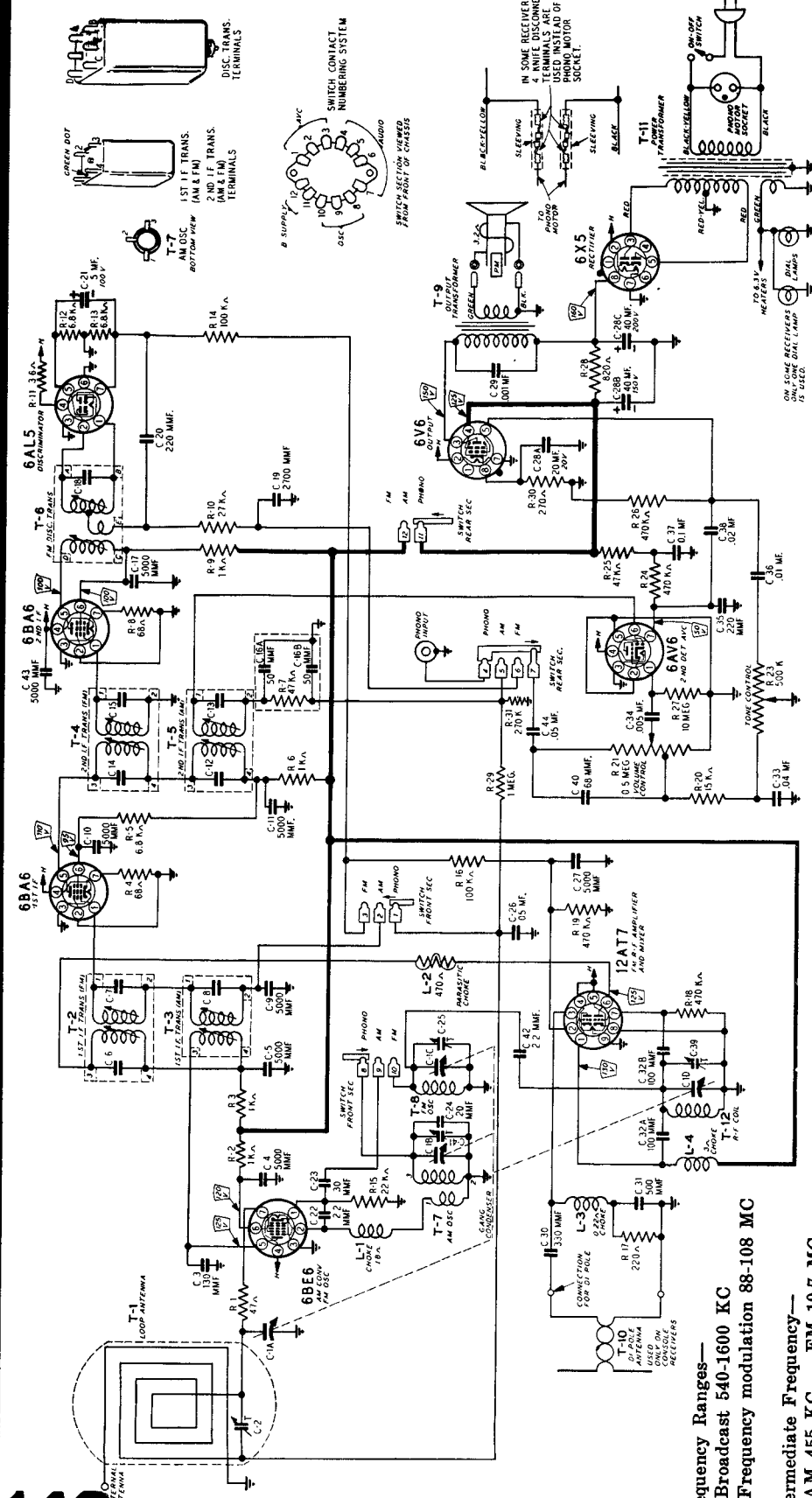

Frequency Ranges—
 Broadcast 540-1600 KC
 Frequency modulation 88-108 MC
Intermediate Frequency—
 AM 455 KC — FM 10.7 MC

TUBE SOCKET VOLTAGES

Socket voltages are shown on the schematic diagram. All voltages are between the socket terminal and chassis with a 1000 ohm-per-volt meter with a 300 volt scale used for plate and screen voltages. Audio grid voltages were read with a vacuum tube volt-meter. Conditions of measurement are:

- Line voltage 117 Volts AC
- Signal Input None
- A Variation of ±10% is usually permissible.

WESTERN AUTO SUPPLY COMPANY

MODEL D1046D
Factory Model 27A96-952

Models D1046 with suffix A, B, and C, and Models D1034A, -B, and -C, are very similar to Model D1046D described on this page.

NOTE — In later production C-33 is .01 mf.

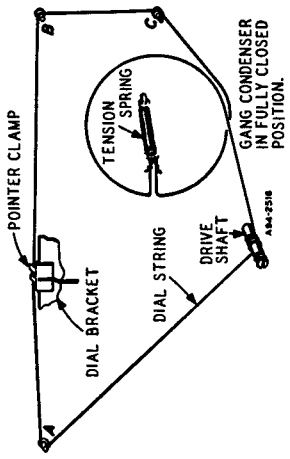

MANUAL OF 1951 MOST-OFTEN-NEEDED RADIO DIAGRAMS

WESTERN AUTO SUPPLY COMPANY

TRUETONE RADIO

MODEL D-2026

Factory Model 8AF29

Series A

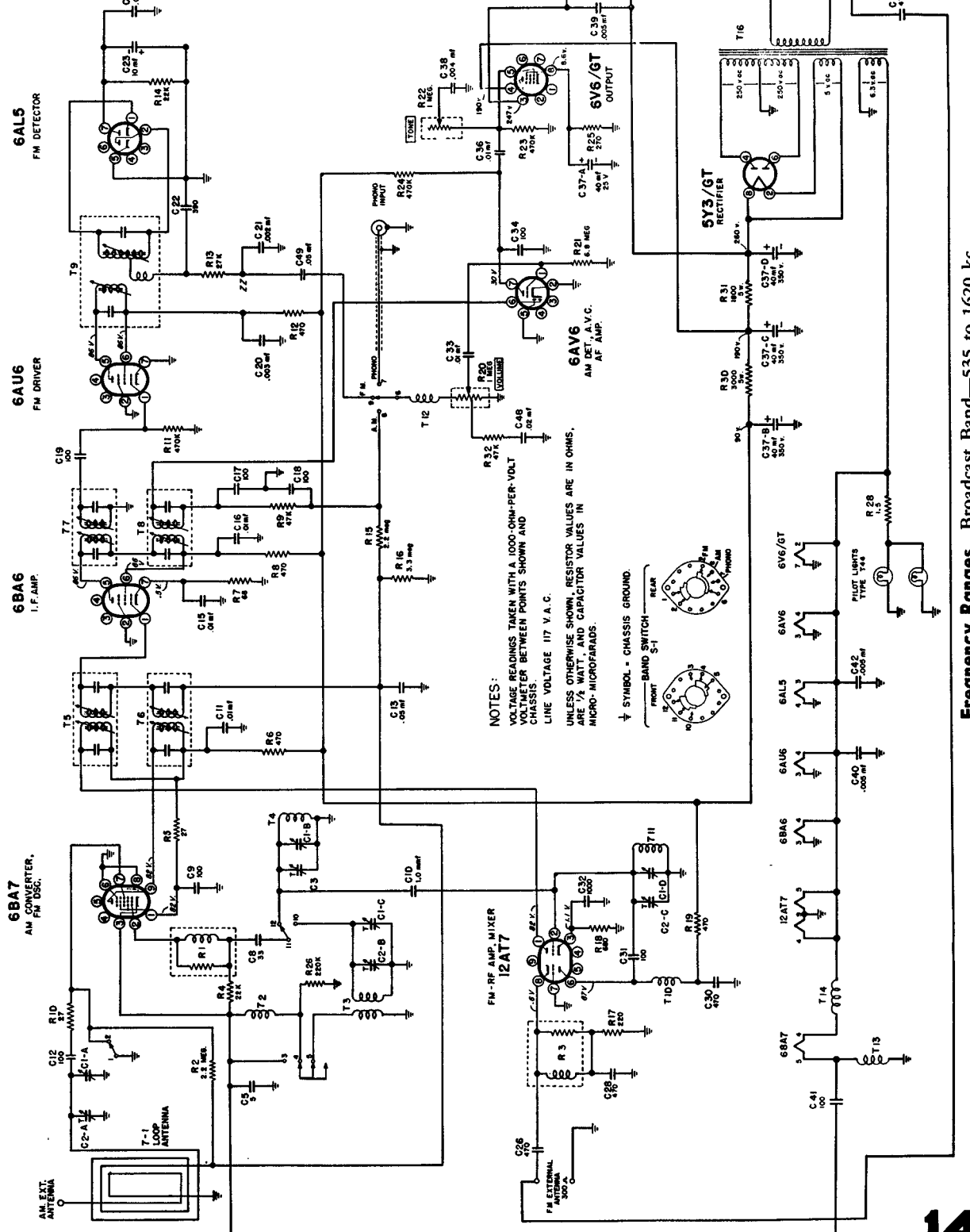

NOTES:
 VOLTAGE READINGS TAKEN WITH A 1000 OHM-PER-VOLT
 CHASSIS GROUND.
 LINE VOLTAGE 117 V. A. C.
 UNLESS OTHERWISE SHOWN, RESISTOR VALUES ARE IN OHMS,
 ARE 1/4 WATT, AND CAPACITOR VALUES IN
 MICRO-MICROFARADS.

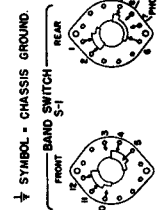

Frequency Ranges... Broadcast Band—535 to 1620 kc.
 FM Band—88 to 108 mc.
 Intermediate Freq... AM-455 kc.; FM-10.7 mc.

ALIGNMENT PROCEDURE A D RECEIVER STAGE SENSITIVITIES

Alignment must be done in the cabinet.

SIGNAL GENERATOR			TUNER SETTING	ADJUST FOR MAXIMUM OUTPUT	INPUT FOR 50 MILLIWATT OUTPUT
Frequency	Coupling Capacitor	Connection to Radio			
455 kc.	.1 mf.	12BE6, Pin 7	Capacitor full open (plates out of mesh)	Top and bottom Cores in output and input I.F. cans	60 microvolts
1620 kc.	.1 mf.	12BE6, Pin 7	Capacitor full open (plates out of mesh)	Oscillator trimmer C1-D on gang	67 microvolts
535 kc.	.1 mf.	12BE6, Pin 7	Capacitor fully closed	Check for adequate range	61 microvolts
1400 kc.	—	Lay Generator lead near back of cabinet.	Set dial pointed at 1400 kc.	Antenna trimmer C1-C on gang	200 to 400 microvolts
400 cycles	.1 mf.	12AT6, Pin 1 or 12AV6	—	—	.03 volts

The signal source must be an accurately calibrated signal generator capable of supplying both 1000 kc and 455 kc signals modulated 30% with a 400-cycle audio signal. Variations in sensitivity of plus or minus 25% are usually permissible.

The table below lists the sensitivity at the input of each stage. All measurements are based on an output of 50 milliwatts. This may be measured by disconnecting the speaker voice coil and substituting a 3.2-ohm, 5-watt resistor across the secondary winding of the output transformer. A reading of 0.4 volts AC across this resistor will be equivalent to a 50-milliwatt output with the speaker connected.

- Loop antenna should be connected to receiver and in its proper position when making adjustments.

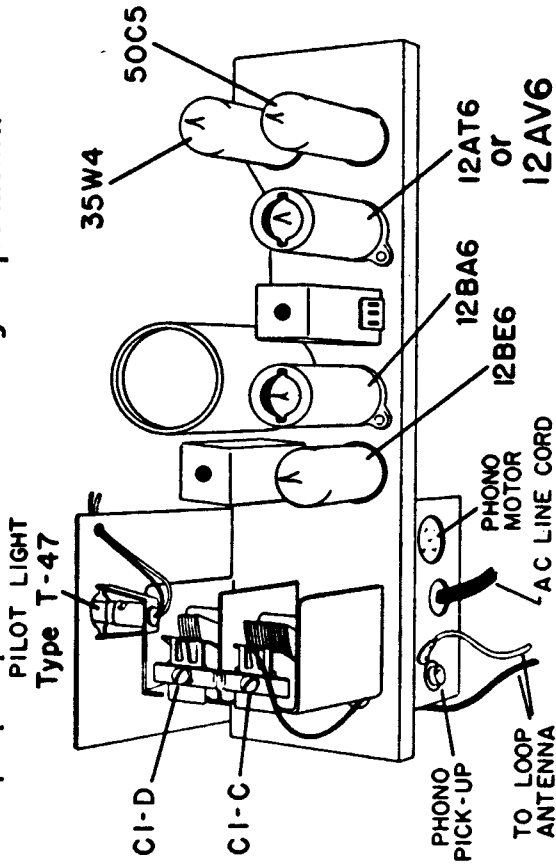

MANUAL OF 1951 MOST-OFTEN-NEEDED RADIO DIAGRAMS

Tru-tone

MODEL D-2042

Factory Model 5D162 Series A

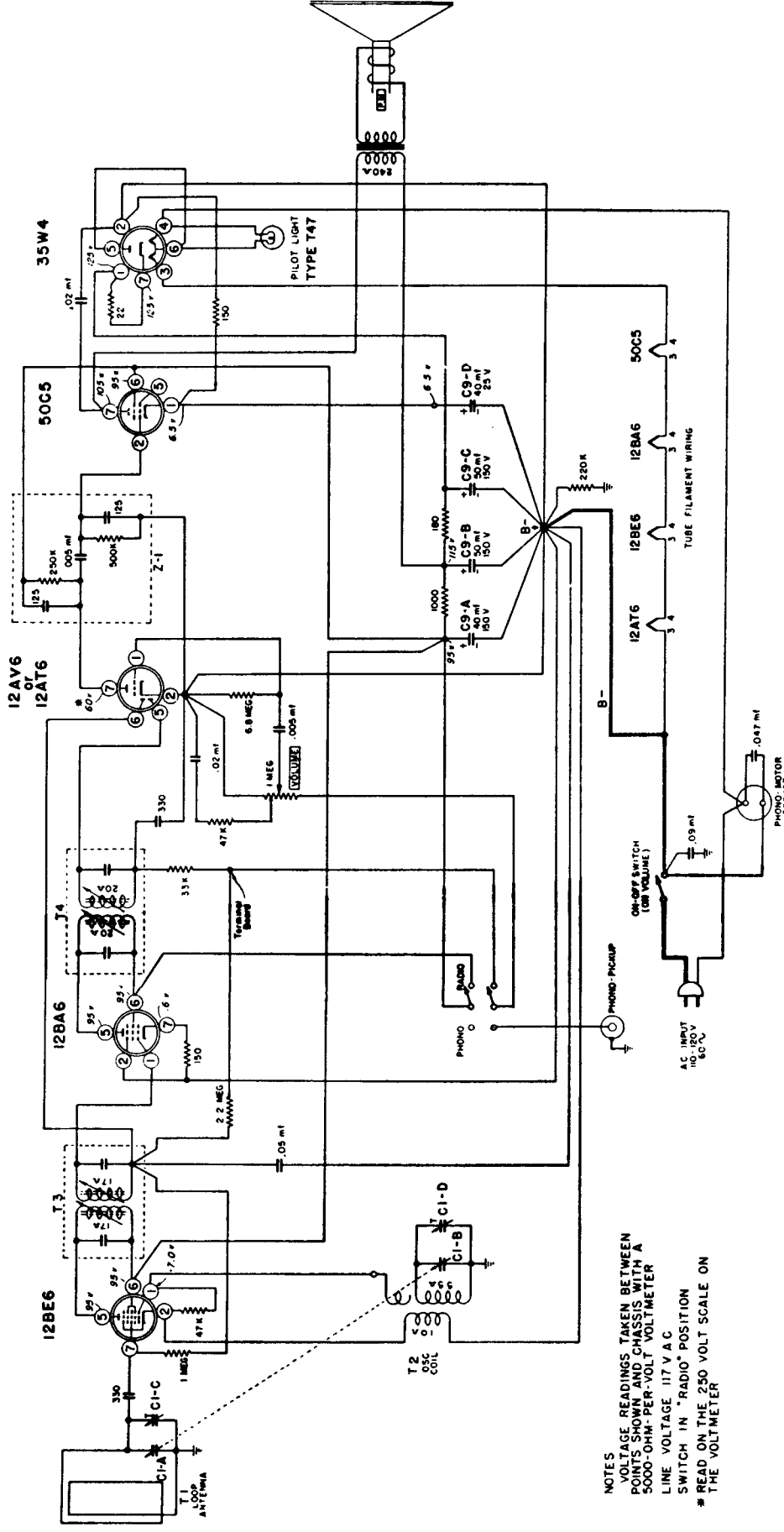

NOTES
 VOLTAGE READINGS TAKEN BETWEEN POINTS SHOWN AND CHASSIS WITH A 5000-OHM-PER-VOLT VOLTMETER
 LINE VOLTAGE 117 V A.C.
 SWITCH IN "RADIO" POSITION
 * READ ON THE 250 VOLT SCALE ON THE VOLTMETER

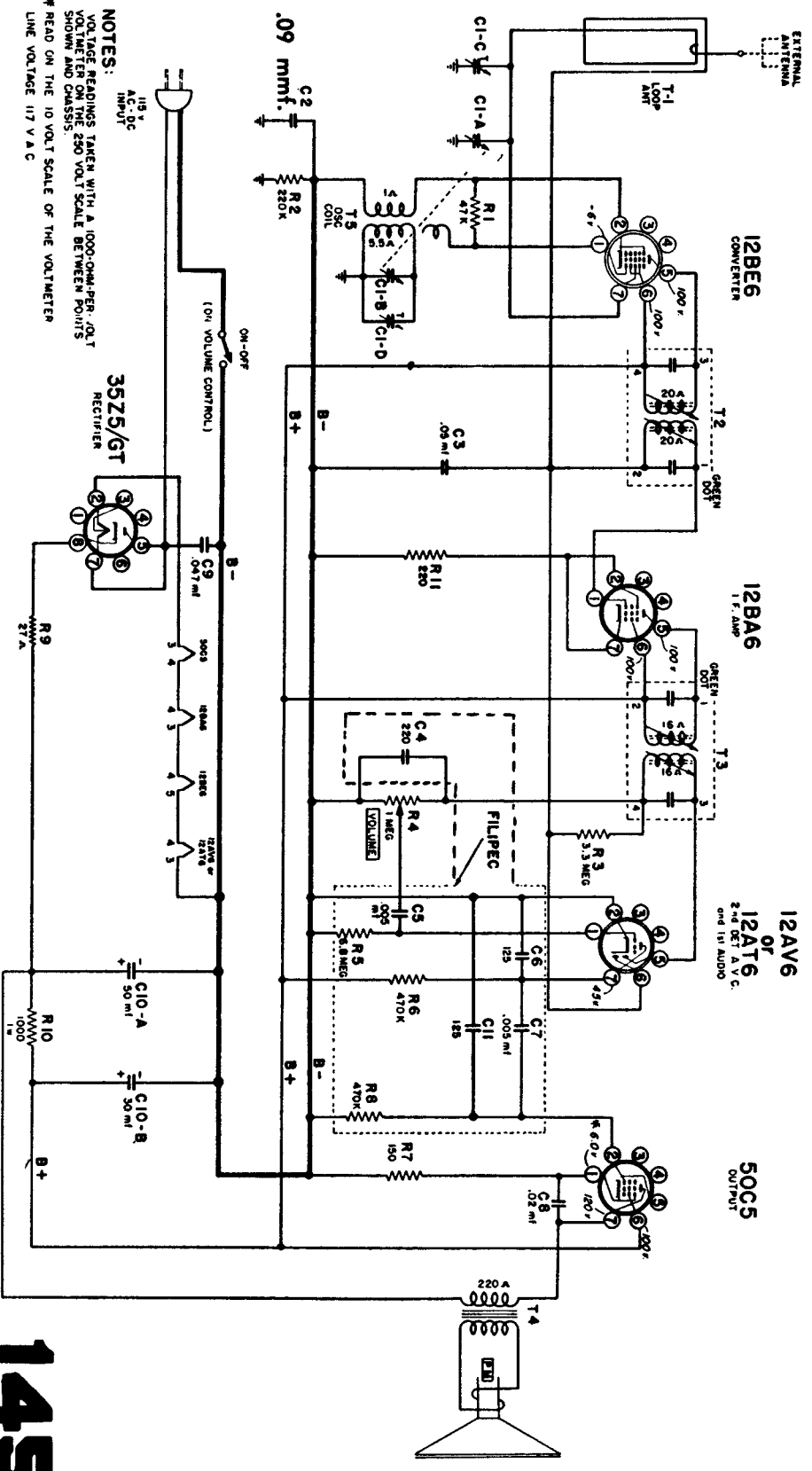

NOTES:
 115 V
 115 V AC
 115 V AC
 VOLTAGE READINGS TAKEN WITH A 1000-OHM- μ SEI
 VOLTMETER ON THE 250 VOLT SCALE BETWEEN POINTS
 SHOWN AND CHASSIS.
 * READ ON THE 10 VOLT SCALE OF THE VOLTMETER
 † LINE VOLTAGE 117 V A.C.

MANUAL OF 1951 MOST-OFTEN-NEEDED RADIO DIAGRAMS

True Tone RADIO

MODEL D-2102A AND D-2103A

Factory Model 5D165

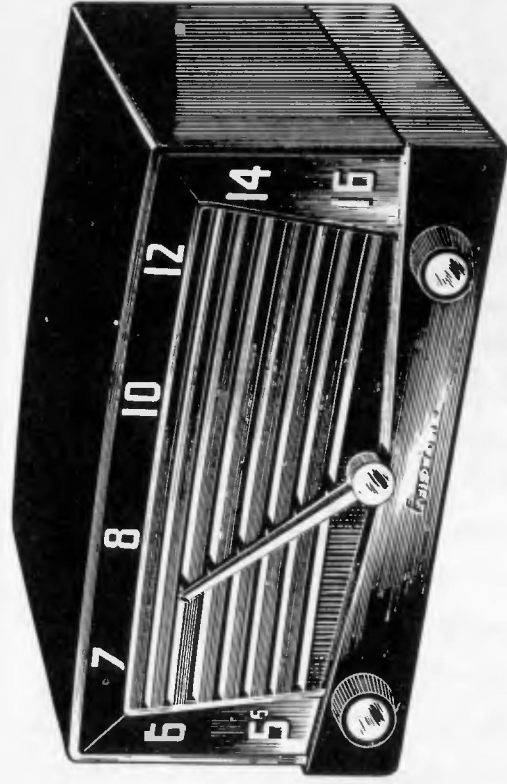

Front Cabinet View

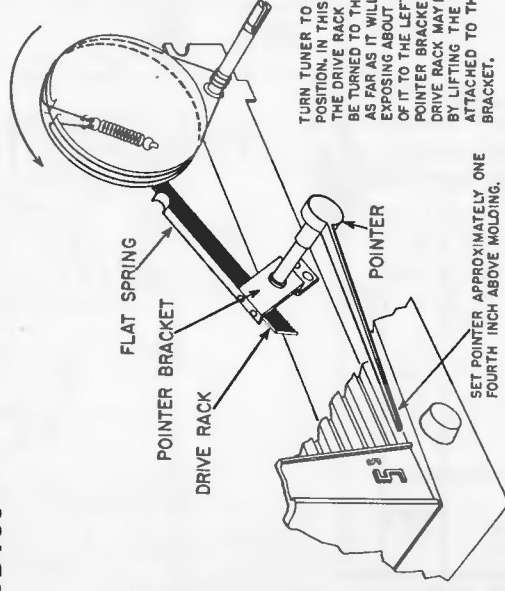

TURN TUNER TO CLOSED POSITION. IN THIS POSITION THE DRIVE RACK WILL BE TURNED TO THE LEFT AS FAR AS IT WILL GO EXPOSING ABOUT ONE HALF INCH OF IT TO THE LEFT OF THE POINTER BRACKET. THE DRIVE RACK MAY BE ADJUSTED BY LIFTING THE FLAT SPRING ATTACHED TO THE POINTER BRACKET.

Dial Stringing Diagram

ALIGNMENT PROCEDURE

- Loop must be connected and set volume to maximum.

SIGNAL GENERATOR			TUNER SETTING	ADJUST FOR MAXIMUM OUTPUT	INPUT FOR 50-MILLIWATT OUTPUT
Frequency	Coupling Capacitor	Connection to Radio			
455 kc.	.1 mf	12BE6, Pin 7	Capacitor fully open (plates out of mesh)	Top and bottom Cores in output and input I.F. cans	65 microvolts
1620 kc.	.1 mf	12BE6, Pin 7	Capacitor fully open (plates out of mesh)	Oscillator trimmer C1-D on gang	70 microvolts
535 kc.	.1 mf.	12BE6, Pin 7	Capacitor fully closed	Check for adequate range	70 microvolts
1400 kc.	_____	Lay generator lead near back of cabinet	Tune in 1400 kc. signal	Antenna trimmer C-1C on gang	200 to 400 microvolts
400 cycles	.1 mf	12AT6, Pin 1	_____	_____	.06 volts

HEAVY BUSS LEAD ACROSS CENTER OF CHASSIS

Ground Connection

MANUAL OF 1951 MOST-OFTEN-NEEDED RADIO DIAGRAMS

WESTERN AUTO SUPPLY COMPANY



MODEL D-3120A

Factory Model 4P11

4 Tube A.C. - D.C. -
Battery Portable
Built-In Antenna
Selenium Rectifier

3V4
AUDIO OUTPUT

1U5
DET.-A.V.C.-A.F.

1U4
I.F. AMP

1R5
CONVERTER

146

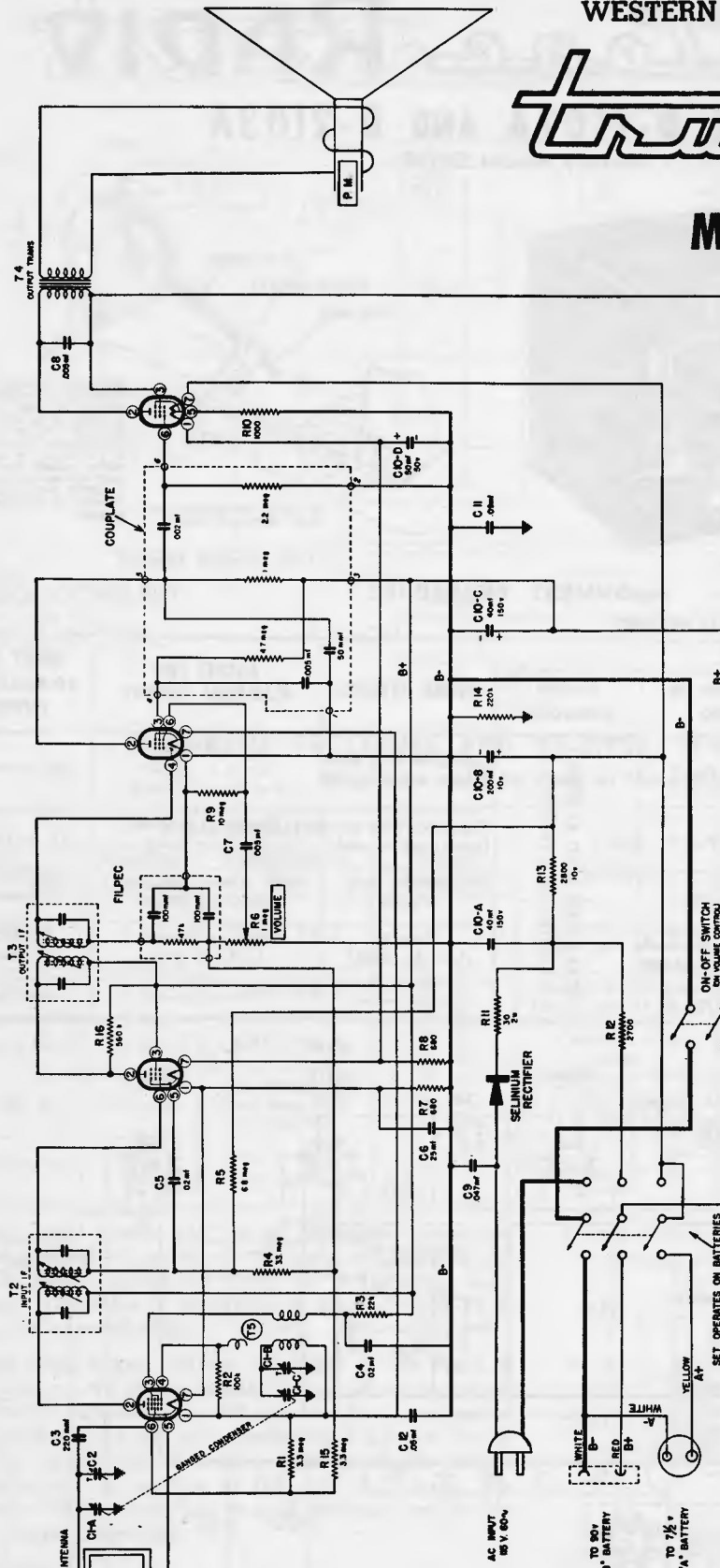

FREQUENCY	COUPLING CAPACITOR	DIAL SETTING	CONNECTION TO RADIO	GROUND CONNECTION	ADJUST	INPUT FOR 50 MILLIWATTS OUTPUT
455 kc.	.1 mfd.	1000 kc.	Pin No. 6 of 1R5	B- (shell of lytic)	I.F. slugs	100 microvolts
1620 kc.	.1 mfd.	1600 kc.	Pin No. 6 of 1R5	B- (shell of lytic)	C1-B Osc. Trim. on gang	_____
1400 kc.	Radiation Loop	1400 kc.	Radiation loop	None	C-2 Antenna Trim. on gang	250 microvolts
400 cycles	.05 mfd.	_____	Pin No. 6 of 1U5	B- (shell of lytic)	_____	.040 volts
400 cycles	.05 mfd.	_____	Pin No. 6 of 3V4	B- (shell of lytic)	_____	3 volts

MANUAL OF 1951 MOST-OFTEN-NEEDED RADIO DIAGRAMS

Western Auto Supply Co.
Truetone Model D4142A

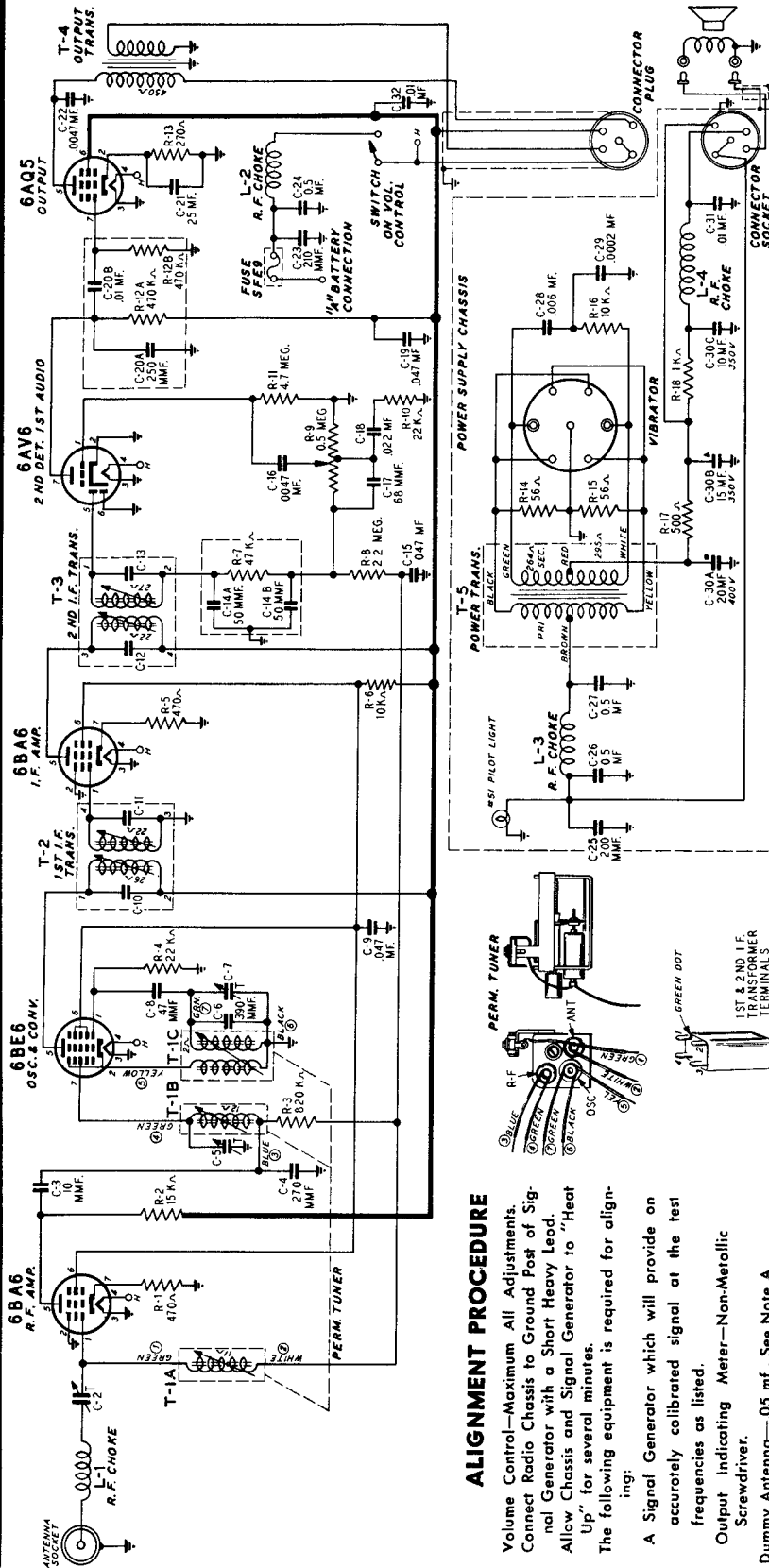

ALIGNMENT PROCEDURE

Volume Control—Maximum All Adjustments.
Connect Radio Chassis to Ground Post of Signal Generator with a Short Heavy Lead.
Allow Chassis and Signal Generator to "Heat Up" for several minutes.
The following equipment is required for aligning:

A Signal Generator which will provide an accurately calibrated signal at the test frequencies as listed.

Output Indicating Meter—Non-Metallic Screwdriver.

Dummy Antenna—.05 mf., See Note A.

SIGNAL GENERATOR FREQUENCY SETTING	CONNECTION AT RADIO	DUMMY ANTENNA	IRON CORE SETTING	ADJUST TUNING SLUGS (IF) AND TRIMMERS TO MAXIMUM (See Fig. 4)
I.F.	Control Grid (prong No. 7)	6BE6 Mixer-Tube	Extreme Position out of Coil	1st I.F. Pri. (1) & Sec. (2) 2nd I.F. Pri. (3) & Sec. (4)
1605 KC	Antenna Cable See Note A	See Note A	Extreme Position out of Coil	Oscillator (C-7)
1605 KC	Antenna Cable See Note A	See Note A	Extreme Position out of Coil	R.F. (C-5) Ant. (C-2)

Reassemble Radio—Install in Car—Connect Car Antenna to Radio.

Car Antenna Readjustment—Tune in weak signal near 1600 KC—Readjust Antenna Trimmer C-2 for maximum output.

Attenuate the signal from the signal generator to prevent the leveling-off action of the AVC.

NOTE A—Insert the antenna cable plug in the antenna socket on the chassis. The total capacity of the antenna cable and dummy antenna should be 60 mmf. If the cable, for example, has a capacity of 30 mmf., use a 30 mmf. condenser for a dummy antenna. Connect the other end of the antenna cable through the dummy antenna capacity to the output of the signal generator.

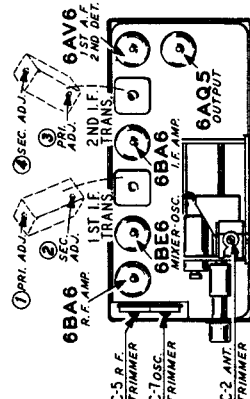

Fig. 4 — Tube Layout

MODEL D4142A

Factory Model 25C23-11

Western Auto Supply Co.

MANUAL OF 1951 MOST-OFTEN-NEEDED RADIO DIAGRAMS

Westinghouse

Models listed at left below correspond exactly to the circuit on this page.

Models	Chassis
H-318T5, H-320T5	V-2157
H-318T5U, H-320T5U	V-2157U
H-321T5, H-322T5	V-2157-1
H-321T5U, H-322T5U	V-2157-1U
H-336T5U, H-337T5U	V-2157U

Similar models are listed below:
 H-323T5, Chassis V-2157-2,
 H-323T5U, Chassis V-2157-2U,
 H-338T5U, H-341T5U, V-2157-4U.

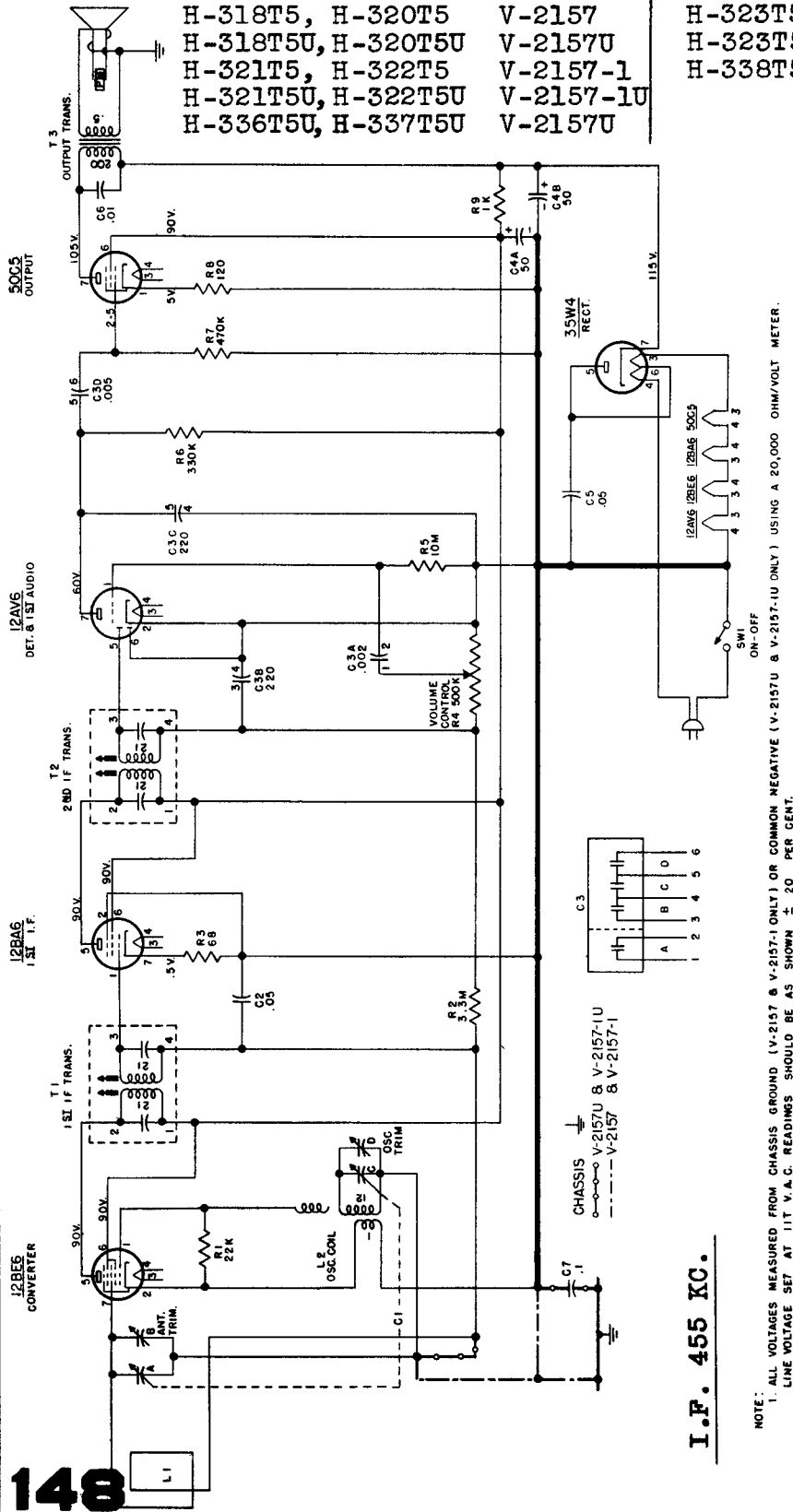

CHASSIS
 V-2157U & V-2157-1U
 V-2157 & V-2157-1

I.F. 455 KC.

NOTE:
 1. ALL VOLTAGES MEASURED FROM CHASSIS GROUND (V-2157 & V-2157-1 ONLY) OR COMMON NEGATIVE (V-2157U & V-2157-1U ONLY) USING A 20,000 OHM/VOLT METER.
 2. LINE VOLTAGE SET AT 117 V.A.C. READINGS SHOULD BE AS SHOWN ± 20 PER CENT.

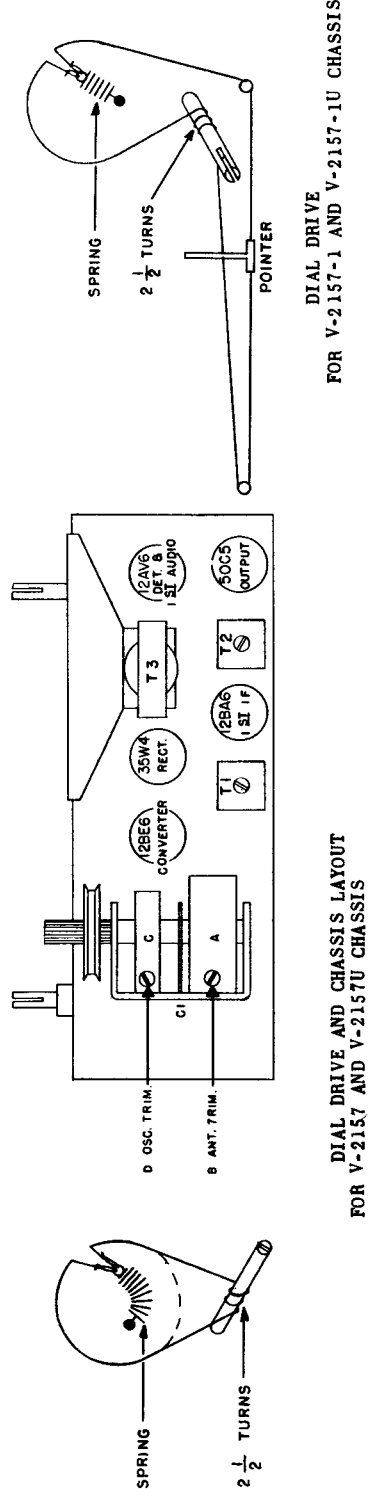

DIAL DRIVE
 FOR V-2157-1 AND V-2157-1U CHASSIS

DIAL DRIVE AND CHASSIS LAYOUT
 FOR V-2157 AND V-2157U CHASSIS

Westinghouse

RADIO TELEVISION

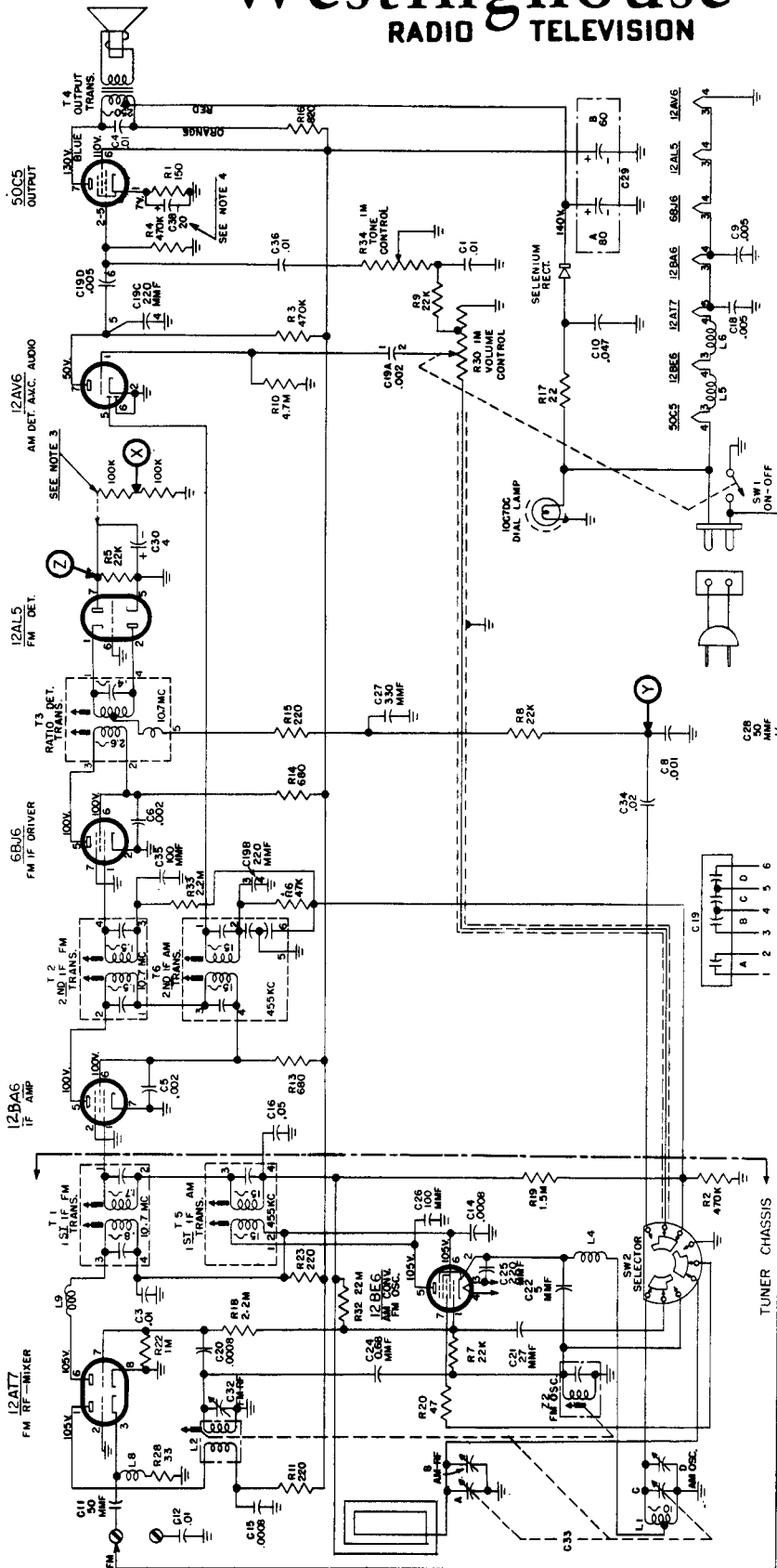

NOTES:

1. SELECTOR SWITCH SW2 IS SHOWN IN EXTREME CLOCKWISE POSITION OR AM BAND.
2. EXTREME COUNTER CLOCKWISE POSITION IS FM BAND.
3. TO BE INSTALLED FOR ALIGNMENT ONLY.
4. C36 MAY OR MAY NOT BE PART OF C29.
5. ALL CAPACITANCE VALUES IN MFD AND ALL RESISTANCE VALUES IN OHMS UNLESS OTHERWISE SPECIFIED.

MODELS H-334T7U AND H-335T7U CHASSIS V-2136-5U

Alignment information for this chassis is given on the reverse side of this page.

There are a number of other Westinghouse receivers designed for AM and FM reception which use the same type of tubes and utilize circuits very similar to V-2136-5U here described. These models are tabulated at right:

Chassis	Models	Type	Changer
V-2136	H-307T7, H-308T7, H-324T7U, H-325T7U	Table	Table
V-2136-1	H-316C7, H-317C7, H-326C7	Comb.	V-9481 V-9840
V-2136-2	H-324T7, H-325T7	Table	
V-2136-4	H-328C7	Comb.	V-9481

150

TOP VIEW OF CHASSIS

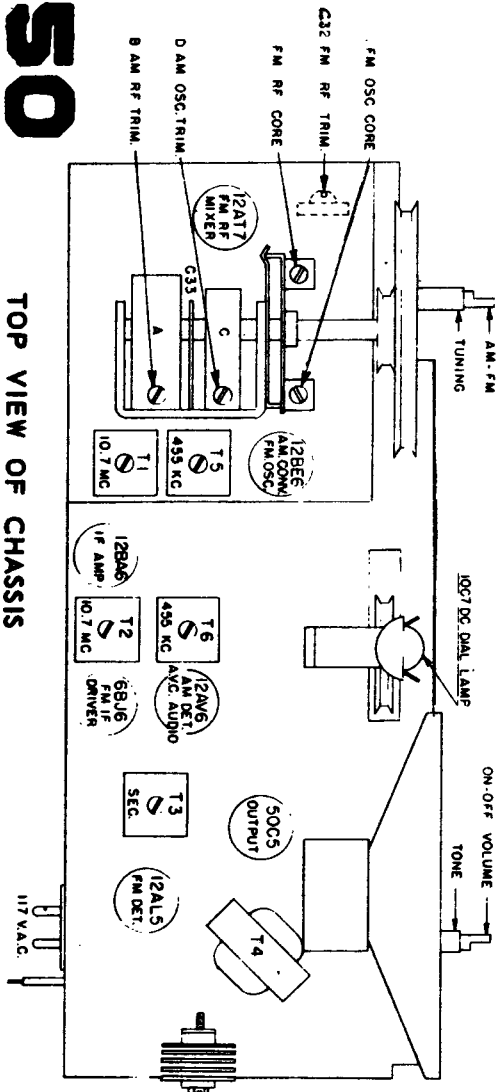

DRIVE MECHANISM

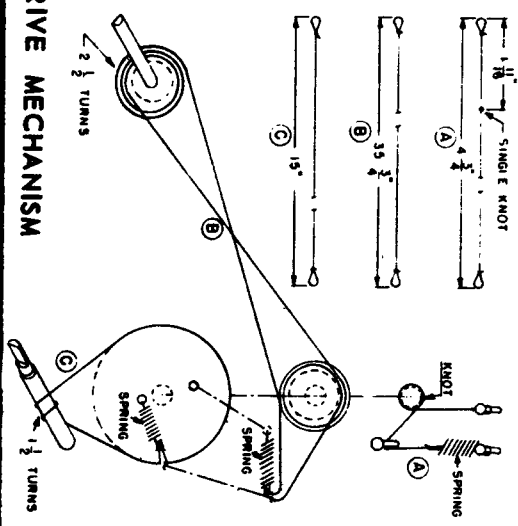

MANUAL OF 1951 MOST-OFTEN-NEEDED RADIO DIAGRAMS

Westinghouse Models H-334T7U and H-335T7U, Chassis V-2136-5U, continued

ALIGNMENT BROADCAST BAND

Connect an output meter across the speaker voice coil.

While making the following adjustments, keep the volume control set for maximum output and the signal generator output attenuated to avoid AVC action.

Check the dial pointer position by meshing the tuning capacitor plates completely and seeing that the dial pointer is set on the end mark of the dial scale.

Step	Connect Signal Generator to —	Signal Generator Frequency	Radio Dial Setting	Adjust
1	Set the band switch to AM			
2	Stator of tuning capacitor (A) through a 0.1 mfd capacitor	455 kc.	minimum capacity	Pri. and sec. of T6 and T5 for max. output in order given
<p><i>NOTE: If the I-F transformers are badly mis-aligned, it may be impossible to obtain sufficient output using the above system. In this event, it will be necessary to align each transformer separately. Start with the last I-F transformer and work forward, connecting the signal generator to the control grid of the tube preceding the transformer under alignment.</i></p>				
3	Radiated signal (no actual connection)	1615 kc.	minimum capacity	AM osc. trimmer (D) for max. output
4	Radiated signal (no actual connection)	1400 kc.	tune to signal	AM R-F trimmer (B) for max. output (rock-in) adjustment

FM BAND

Do not align the FM circuits until all AM adjustments have been completed.

Step	Connect Signal Generator to —	Signal Generator Frequency	Radio Dial Setting	Adjust
1	Set the band switch to FM			
2	Connect two 100,000 ohm resistors (the resistances must be equal within 5 per cent) between pin No. 7 of the 12AL5 tube and ground as shown on the schematic diagram.			
3	Connect a V.T.V.M. between points "X" and "Y" (see schematic diagram).			
4	Pin No. 7 of 12AT7 through a .01 mfd mica capacitor	10.7 mc.	minimum capacity	Sec. of T3 for zero (use medium strength signal)
5	Connect the V.T.V.M. between point "Z" and ground.			
6	Same as step 4	10.7 mc.	minimum capacity	Pri. of T3 and pri. and sec. of T1 and T2 for maximum voltage
7	Reconnect the V.T.V.M. between points "X" and "Y" and increase the signal strength 10 times.			
8	Same as step 4	10.7 mc.	minimum capacity	Recheck sec. of T3 for zero voltage
9	Reconnect the V.T.V.M. between point "Z" and ground.			
10	Same as step 4	10.7 mc.	min. cap.	Pri. of T3 for maximum voltage
11	Remove the two 100,000 ohm resistors that were inserted in step 2.			
12	FM ant. terminal through a 300 ohm non-inductive resistor	98 mc.	98 mc.	FM osc. core for maximum voltage
13	Same as step 12	98 mc.	98 mc.	FM R-F trimmer (C32) for maximum voltage
14	Same as step 12	105 mc.	tune to signal	FMR-F core for maximum voltage
15	Same as step 12	90 mc.	tune to signal	FM R-F trimmer (C32) for maximum voltage (rock-in)
16	Recheck steps 14 and 15 for tracking.			

MANUAL OF 1951 MOST-OFTEN-NEEDED RADIO DIAGRAMS

Westinghouse CHASSIS V-2156-1U MODELS H-342P5U AND H-343P5U

Models H-309P5 and H-309P5U, Chassis V-2156, is similar.

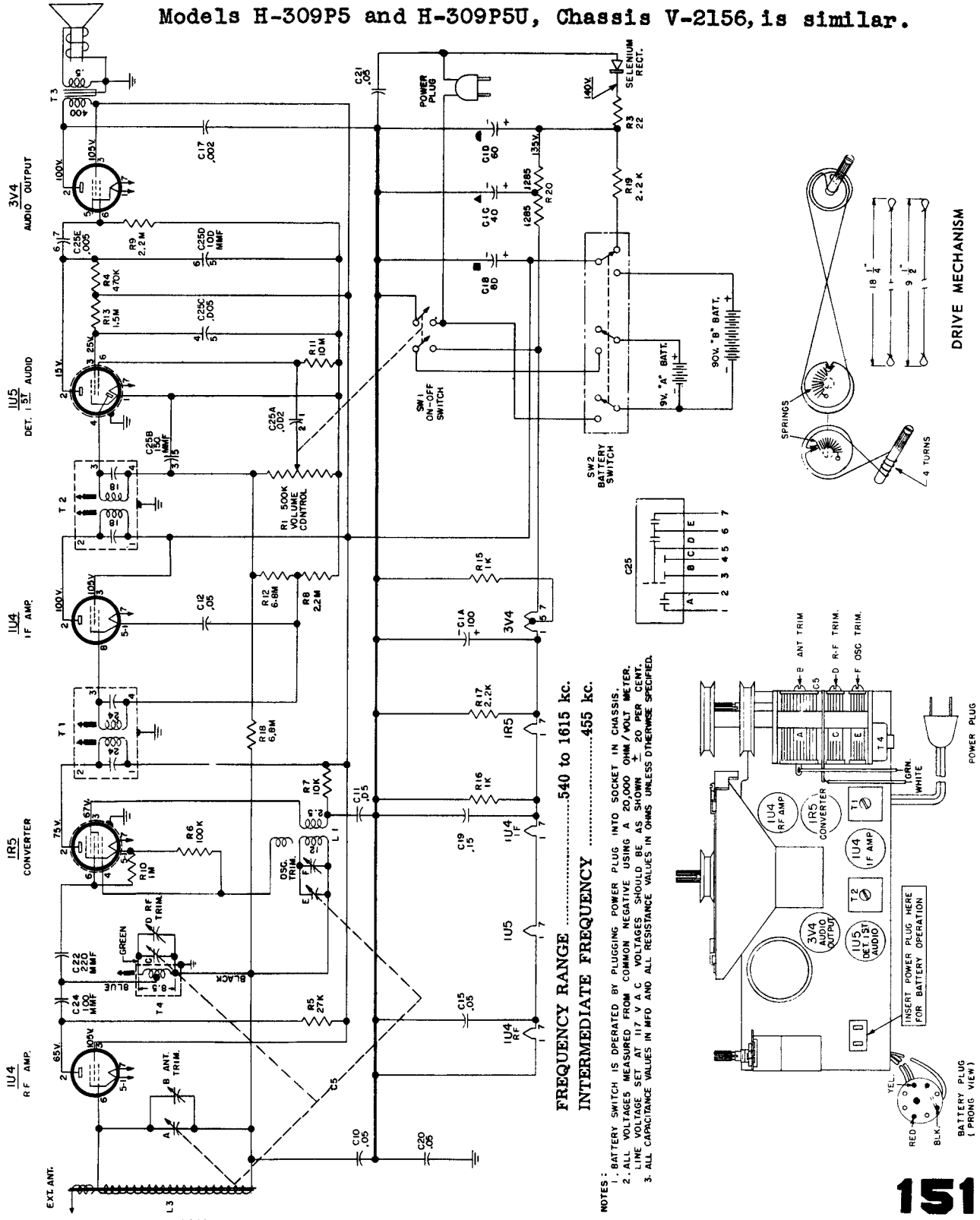

FREQUENCY RANGE 540 to 1615 kc.
INTERMEDIATE FREQUENCY 455 kc.

- NOTES:
1. BATTERY SWITCH IS OPERATED BY PLUGGING POWER PLUG INTO SOCKET IN CHASSIS.
 2. ALL VOLTAGES MEASURED FROM COMMON NEGATIVE USING A 20,000 OHM/VOLT METER. LINE VOLTAGE SET AT 117 V A C VOLTAGES SHOULD BE AS SHOWN ± 20 PER CENT.
 3. ALL CAPACITANCE VALUES IN MFD AND ALL RESISTANCE VALUES IN OHMS UNLESS OTHERWISE SPECIFIED.

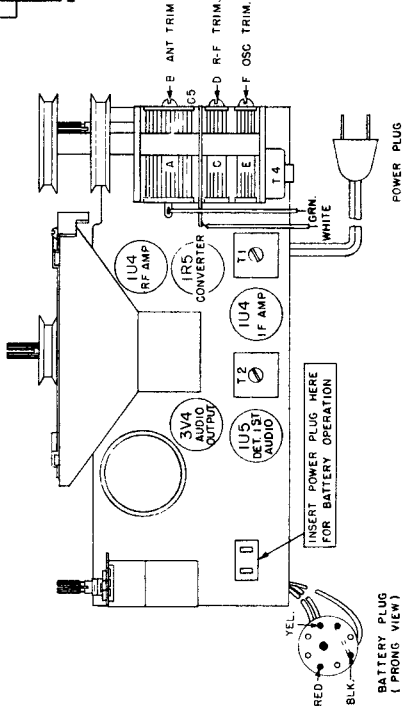

MANUAL OF 1951 MOST-OFTEN-NEEDED RADIO DIAGRAMS

ZENITH MODELS H511, H511Y, H511W, CHASSIS 5H01

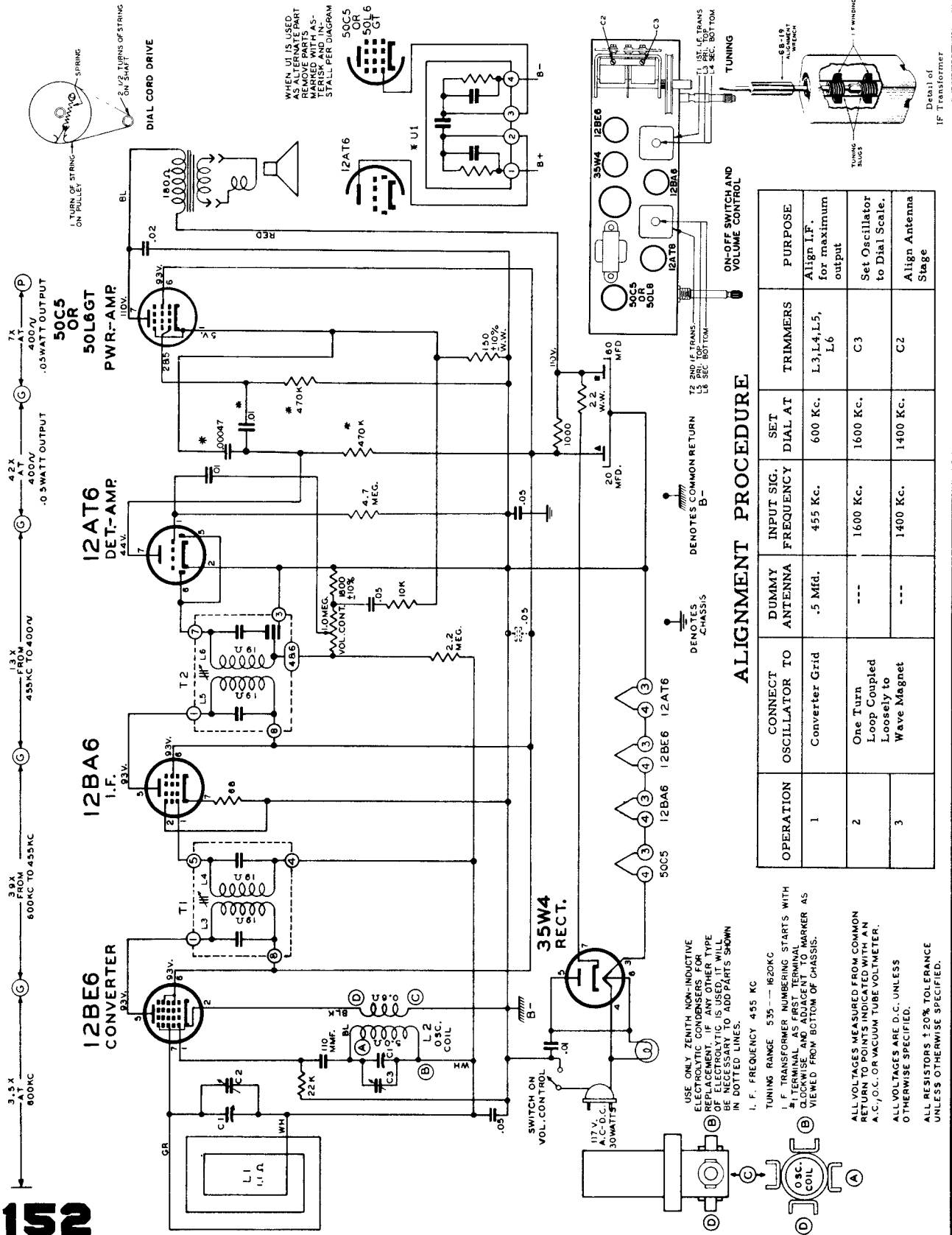

ALIGNMENT PROCEDURE

OPERATION	CONNECT OSCILLATOR TO	DUMMY ANTENNA	INPUT SIG. FREQUENCY	SET DIAL AT	TRIMMERS	PURPOSE
1	Converter Grid	.5 Mfd.	455 Kc.	600 Kc.	L3, L4, L5, L6	Align I.F. for maximum output
2	One Turn Loop Coupled Loosely to Wave Magnet	---	1600 Kc.	1600 Kc.	C3	Set Oscillator to Dial Scale.
3		---	1400 Kc.	1400 Kc.	C2	Align Antenna Stage

1951 MOST-OFTEN-NEEDED RADIO DIAGRAMS

MODELS H665, H665R, H665Z, H665RZ, H661E & H661R
CHASSIS 6H01

Zenith Model H664, Chassis 6H02,
is similar to Chassis 6H01.

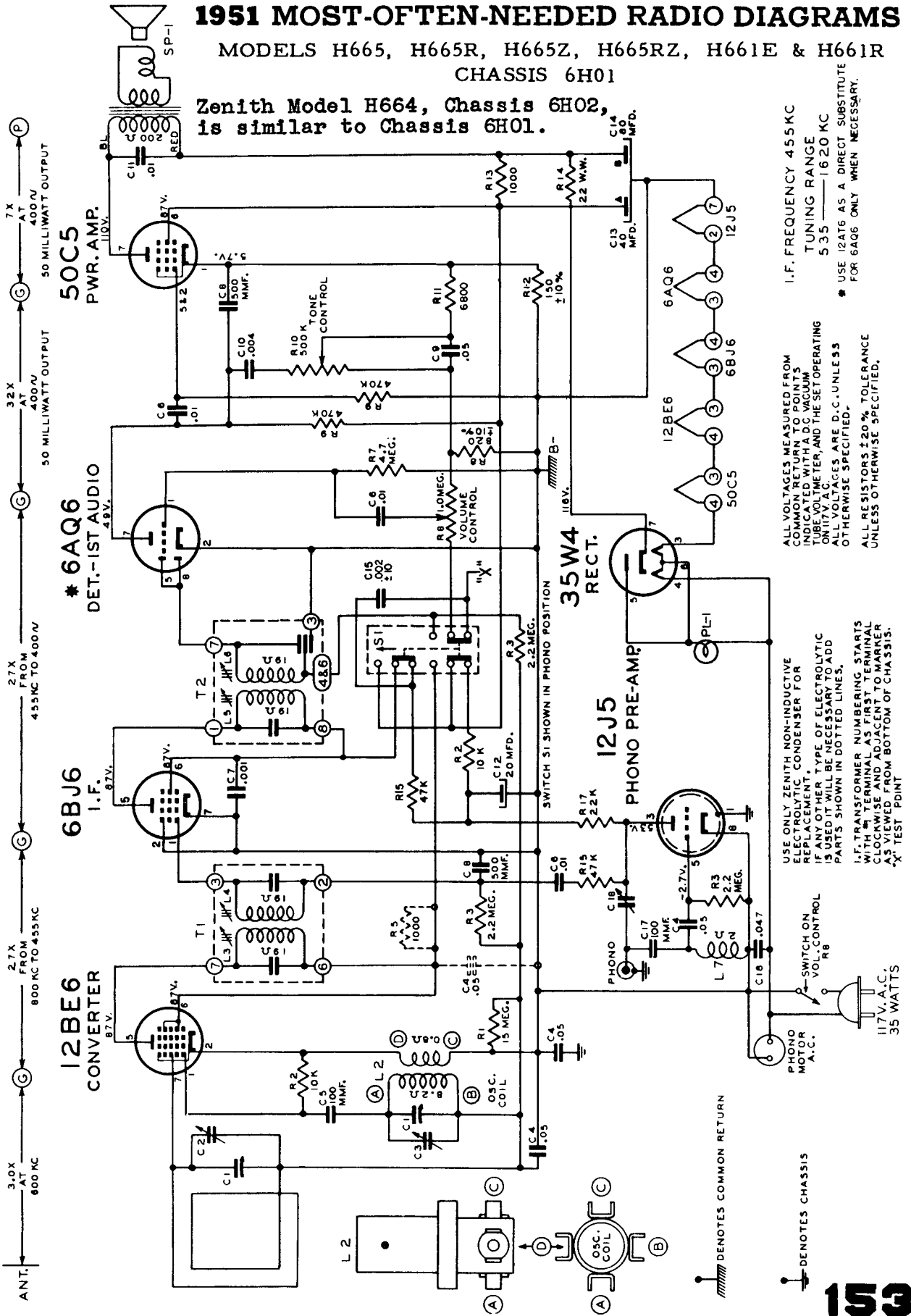

I.F. FREQUENCY 455 KC
TUNING RANGE
5.35 — 16.20 KC
* USE 12AT6 AS A DIRECT SUBSTITUTE
FOR 6AQ6 ONLY WHEN NECESSARY.
ALL VOLTAGES MEASURED FROM
COMMON RETURN TO POINTS
INDICATED WITH A D.C. VACUUM
TUBE VOLTMETER, AND THE SET OPERATING
ON 117V. A.C.
ALL VOLTAGES ARE D.C. UNLESS
OTHERWISE SPECIFIED.
ALL RESISTORS ±20% TOLERANCE
UNLESS OTHERWISE SPECIFIED.

USE ONLY ZENITH NON-INDUCTIVE
ELECTROLYTIC CONDENSER FOR
REPLACEMENT.
IF ANY OTHER TYPE OF ELECTROLYTIC
IS USED IT WILL BE NECESSARY TO ADD
PARTS SHOWN IN DOTTED LINES.
I.F. TRANSFORMER NUMBERING STARTS
WITH THE PRIMARY AND ADJACENT
CLOCKWISE AND ADJACENT TO MARKER
AS VIEWED FROM BOTTOM OF CHASSIS.
* X TEST POINT

PHONO MOTOR A.C.
SWITCH ON VOL. CONTROL
R8

PHONO MOTOR A.C.
SWITCH ON VOL. CONTROL
R8

MANUAL OF 1951 MOST-OFTEN-NEEDED RADIO DIAGRAMS

Zenith Radio Corp. Model H724Z, Chassis 7H02Z

Zenith Model H724, Chassis 7H02, is identical to the "Z" version covered on this page, except for radiation proofing (use of chokes, shielding, etc.).

For alignment, the procedure outlined at the bottom of the schematic on this page should be used with the alignment table on page 155.

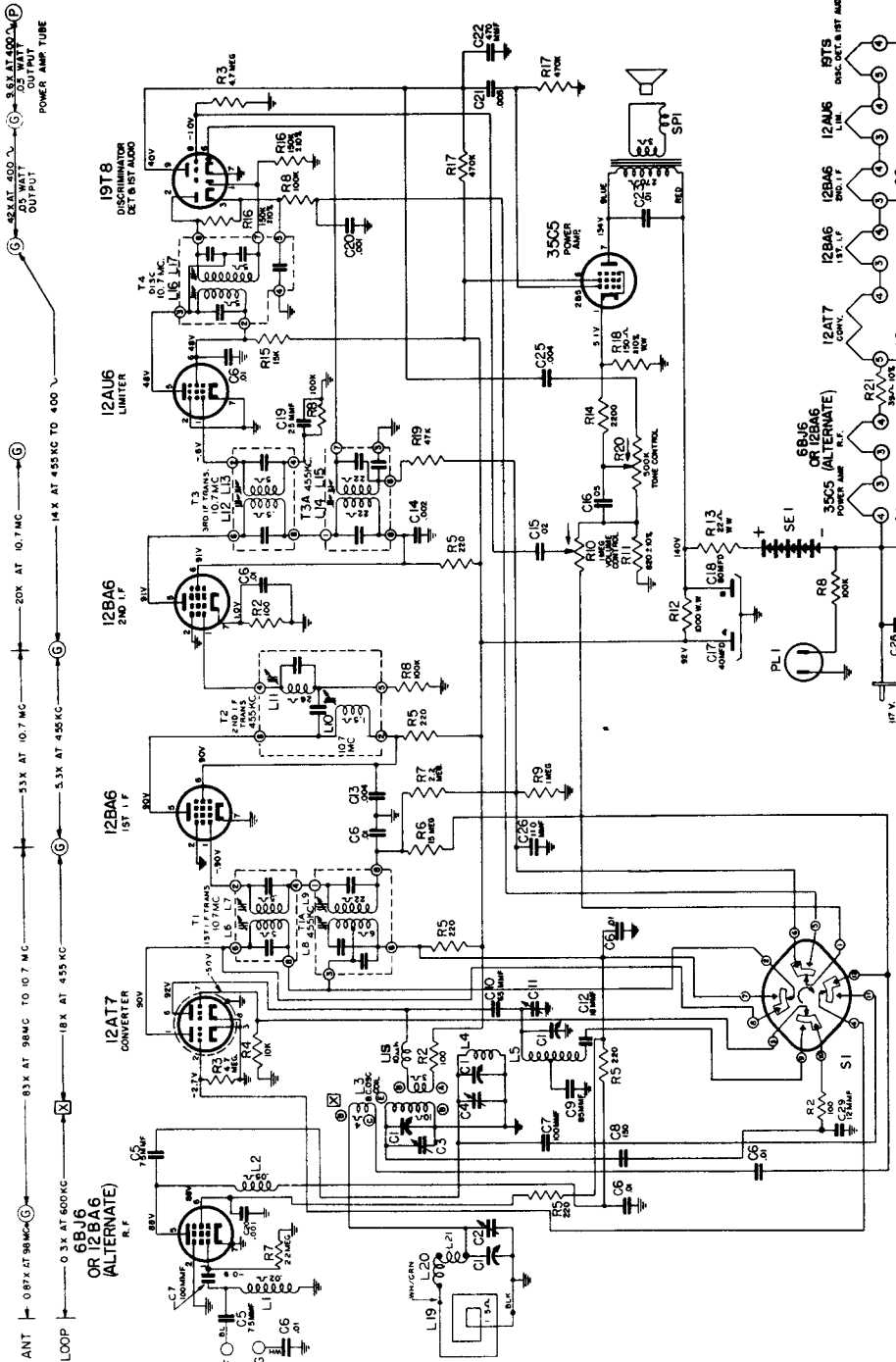

ANT 0.874.17 90 MC
 LOOP 0.3 X AT 600 KC
 6BJ6 OR 12BA6 (ALTERNATE) R.F.
 0.3 X AT 98 MC TO 10.7 MC
 18 X AT 455 KC
 12AT7 CONVERTER 90V
 33 X AT 10.7 MC
 5.3 X AT 455 KC
 12BA6 1ST I.F. 80V
 10 X AT 10.7 MC
 14 X AT 455 KC TO 400 V
 12AU6 LIMITER 48V
 19T8 DISCRIMINATOR 6.16 DISCRIMINATOR
 40 WATT OUTPUT
 0.5 WATT OUTPUT
 8.5 X AT 400 P
 POWER AMP TUBE

BANDSWITCH SHOWN IN STANDARD BROADCAST POSITION.
 SWITCHER CLOCKWISE POSITION AS VIEWED FROM FRONT
 BANDSWITCH POSITIONS (S20 POS. F.M. 100 MC.
 ARROW ON CONTROLS INDICATE CLOCKWISE ROTATION.
 ALL VOLTAGES MEASURED FROM COMMON RETURN TO
 TUBE VOLTMETER WITH AN A.C. D.C. VACUUM
 TUBE VOLTMETER.
 ALL VOLTAGES ARE D.C. UNLESS OTHERWISE SPECIFIED.
 ALL RESISTORS ARE $\pm 20\%$ UNLESS OTHERWISE SPECIFIED.
 DENOTES CHASSIS
 AMP MOD I.F. FREQUENCY 455 KC
 FREQ MOD I.F. FREQUENCY 10.7 MC
 TUNING RANGES 88 - 108 M.C. FREQUENCY MOD.
 TUNING RANGES 540 - 1620 K.C. STANDARD BROADCAST.

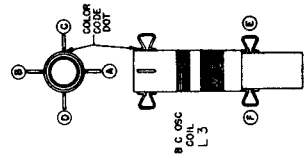

A vacuum tube voltmeter with an isolation resistor of 2,000,000 ohms in series with the hot lead will serve for FM adjustments. This lead should be shielded.

An AC output meter connected across the primary or secondary of the output transformer will be satisfactory for all AM adjustments.

- The signal generator output should be kept just high enough to get an indication on the meter.
- (a) Vacuum Tube Voltmeter Lug 7 on discriminator transformer to chassis is (half discriminator load).
 - (b) Vacuum Tube Voltmeter Lug 5 on discriminator transformer to chassis is (full discriminator load).
 - (c) Vacuum Tube Voltmeter from Limiter Grid to Chassis.
 - (d) Loosen Slugs by applying a hot iron to the cement.

MODEL H724Z
 CHASSIS 7H02Z

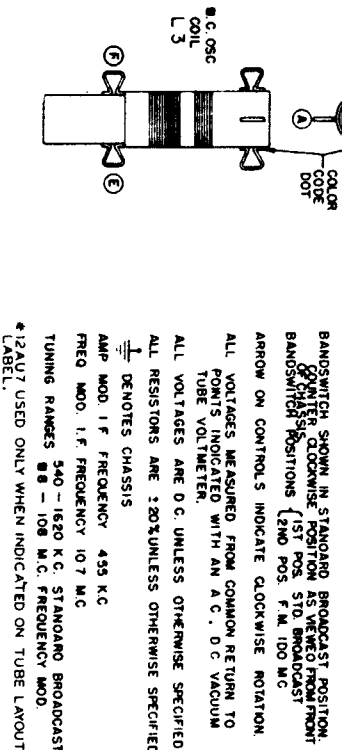

DIAL CORD DRIVE

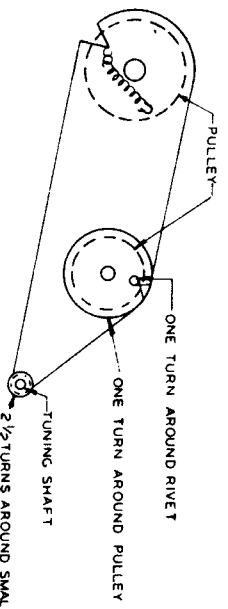

ALIGNMENT

	Connect Oscillator to	Dummy Antenna	Input Signal Frequency	Band	Dial	Adj. Trimmers	Purpose
1	Pin 2-12AT7 or 12AU7 Converter	.05 Mfd.	455 KC. Modulated	BC 600 Kc.	L8, 9, 11, 14, 15	Align I. F. channel for maximum output.	Align I. F. channel for maximum output.
2	2 turns loosely cpd. to wavemagnet		1600 Kc. Modulated	BC1600 Kc.	C3	Set oscillator to dial scale.	Set oscillator to dial scale.
3	2 turns loosely cpd. to wavemagnet		1400 Kc. Modulated	BC1400 Kc.	C2	Align antenna stage.	Align antenna stage.
4(a)	Pin 1 (grid) on 12AU6 limiter.	.05 Mfd.	10.7 Mc. Unmodulated	FM	L16 coil slug	Align primary of discriminator for maximum reading.	Align primary of discriminator for maximum reading.
5(b)	Pin 1 (grid) on 12AU6 limiter.	.05 Mfd.	10.7 Mc. Unmodulated	FM	L17 coil slug	Adjust secondary of discriminator for zero reading.	Adjust secondary of discriminator for zero reading.
6(c)	Pin 1 (grid) on 12BA6 2nd IF.	.05 Mfd.	10.7 Mc. Unmodulated	FM	L12 and 13 Prim and Sec. of 3rd IF trans.	Align 3rd IF transformer for maximum reading.	Align 3rd IF transformer for maximum reading.
7(c)	Pin 1 (grid) on 12BA6 1st IF.	.05 Mfd.	10.7 Mc. Unmodulated	FM	L10 Prim. of 2nd IF transformer.	Align 2nd IF transformer for maximum reading.	Align 2nd IF transformer for maximum reading.
8(c)	Pin 2 (grid) on 12AT7 or 12AU7 converter tube socket.	.05 Mfd.	10.7 Mc. Unmodulated	FM	L6 and L7 Prim. and Sec. of 1st IF transformer.	Align 1st IF transformer for maximum reading.	Align 1st IF transformer for maximum reading.
9(c)	Antenna Post FM (Re-move line ant.)	270 ohms	98 Mc. Unmodulated	FM 98 Mc.	C11 Osc. Coil.	Set Oscillator to dial scale.	Set Oscillator to dial scale.
10(c)	Antenna Post FM (Re-move line ant.)	270 ohms	98 Mc. Unmodulated	FM 98 Mc.	C4 Det. Coil.	Align det. stage to max. reading.	Align det. stage to max. reading.

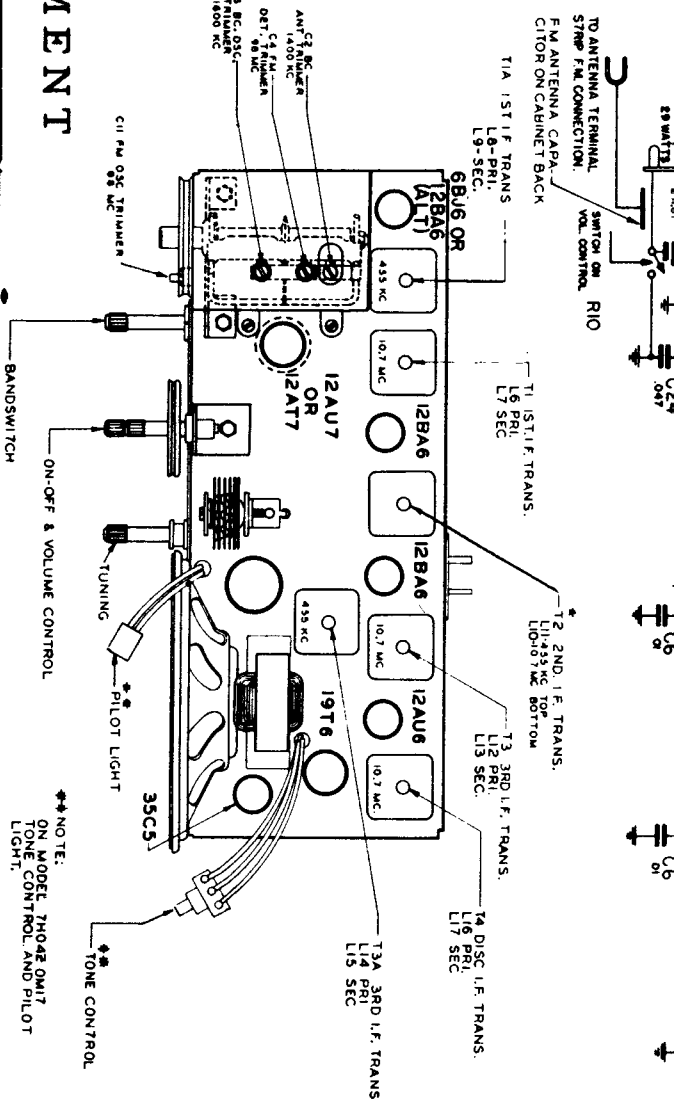

MANUAL OF 1951 MOST-OFTEN-NEEDED RADIO DIAGRAMS

6B46
OR 12B46
(ALTERNATE)
R.F.

12A17 OR #12A17
CONVERTER
30V

12B46
1ST I.F.

12B46
2ND I.F.

12A16
LIMITER

19T8
DISCRIMINATOR
DET. B.I.S.T. AUDIO

MODEL H 7 2 3 Z

CHASSIS 7 H 0 4 Z

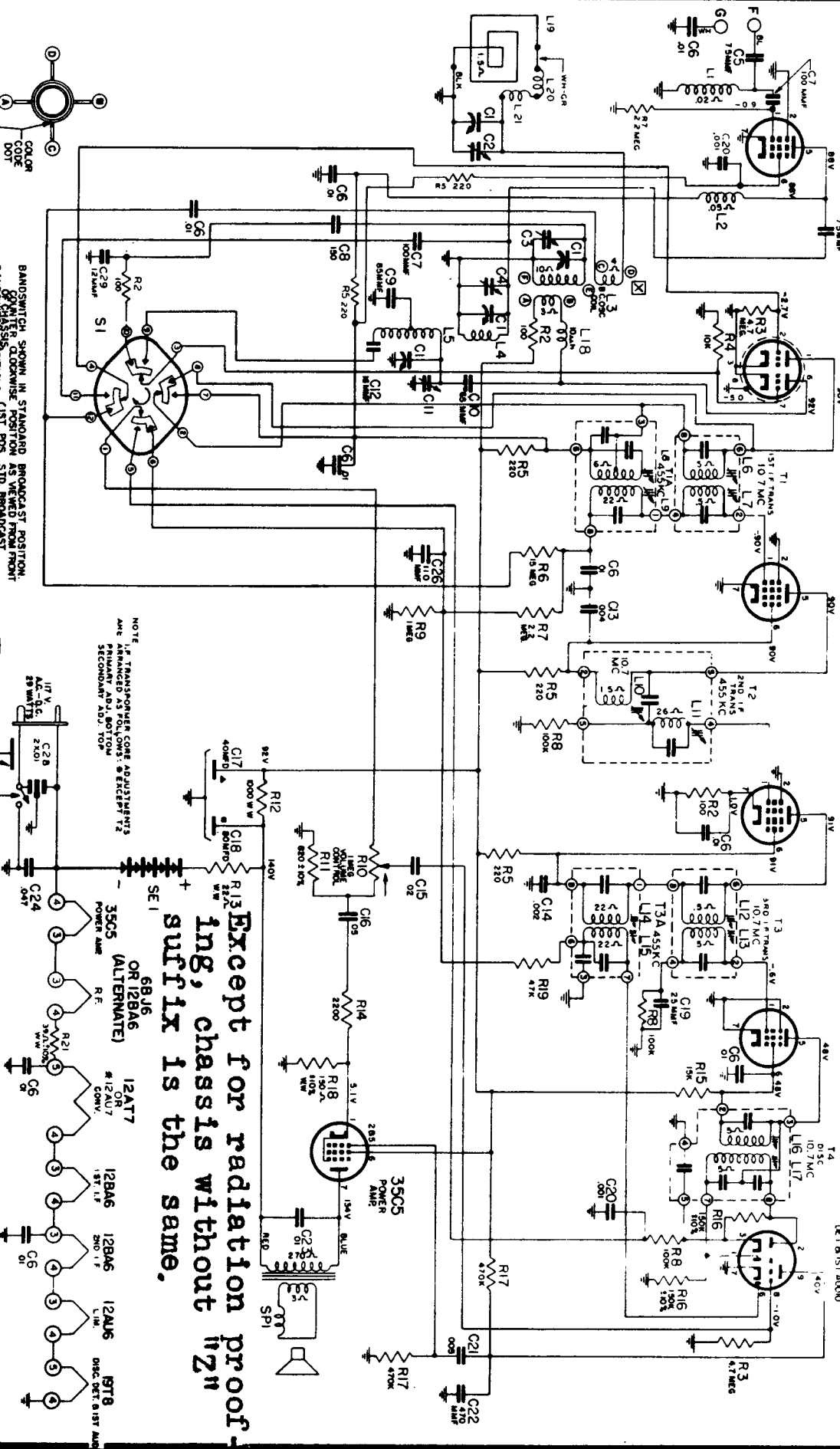

Except for radiation proofing, chassis without suffix is the same.

BANDSWITCH SHOWN IN STANDARD BROADCAST POSITION. SWITCH CLOCKWISE: 1ST POS. STD. BROADCAST BANDSWITCH POSITIONS; 2ND POS. F.M. 100 MC. ARROW ON CONTROLS INDICATE CLOCKWISE ROTATION.

NOTE: IF TRANSFORMER CORE ADJUSTMENTS ARE PROVIDED IN RECEIPT, SECONDARY ADV. TOP.

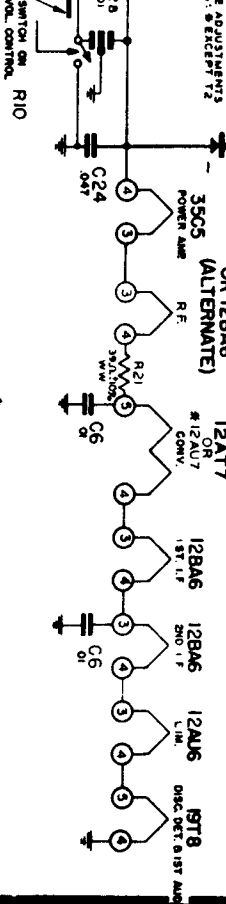

ALL VOLTAGES MEASURED FROM COMMON REF. UNLESS INDICATED OTHERWISE.

ZENITH RADIO CORP. * ALIGNMENT PROCEDURE * MODEL H880RZ, CHASSIS 8H20
 (See page 157 for schematic diagram).

MANUAL OF 1951 MOST-OFTEN-NEEDED RADIO

	Connect Oscillator To	Dummy Antenna	Input Signal Frequency	Band	Set Dial To	Adj. Trimmers	Purpose
1	Pin 2 12A7 Converter	.05 Mfd.	455 Kc.	BC	600 Kc.	L9, 10, 13, 14	Align I. F. channel for maximum output.
2	2 turns loosely cpd. to wavemagnet		1600 Kc.	BC	1600 Kc.	C4	Set oscillator to dial scale.
3	2 turns loosely cpd. to wavemagnet		1400 Kc.	BC	1400 Kc.	C3, C2	Align detector and antenna stage.
4 (a)	Pin 1 (grid) on 12AU6 limiter.	.05 Mfd.	10.7 Mc.	FM		L16 coil slug Primary discr.	Align primary of discriminator for maximum reading.
5 (b)	Pin 1 (grid) on 12AU6 limiter.	.05 Mfd.	10.7 Mc.	FM		L17 coil slug sec. of discr.	Adjust secondary of discriminator for zero reading.
6 (c)	Pin 1 (grid) on 12BA6 2nd. I.F.	.05 Mfd.	10.7 Mc.	FM		L15 Prim. of 3rd. IF trans.	Align 3rd. IF transformer for maximum reading.
7 (c)	Pin 1 (grid) on 12BA6 1st. IF.	.05 Mfd.	10.7 Mc.	FM		L11 and L12 Prim. and Sec. of 2nd. IF transformer.	Align 2nd IF transformer for maximum reading.
8 (c)	Pin 2 (grid) on 12A7 converter tube socket.	.05 Mfd.	10.7 Mc.	FM		L7 and L8 Prim. and Sec. of 1st. IF transformer.	Align 1st. IF transformer for maximum reading.
9 (c)	Antenna Post FM (Remove line ant.)	270 ohms	98 Mc.	FM	98 Mc.	L5 Osc. Coil Slug.	Set Oscillator to dial scale.
10 (c) (d)		270 ohms	98 Mc.	FM	98 Mc.	L3 Det. Coil Slug	Align det. stage to maximum reading.

Correct alignment can only be made if the following procedure is followed:

A vacuum tube voltmeter with an isolation resistor of 2,000,000 ohms in series with the hot lead will serve for FM adjustments. This lead should be shielded.

An AC output meter connected across the primary or secondary of the output transformer will be satisfactory for all AM adjustments.

The signal generator output should be kept just high enough to get an indication on the meter.

(a) Vacuum Tube Voltmeter Lug 7 on discriminator transformer to chassis (half discriminator load).

(b) Vacuum Tube Voltmeter Lug 5 on discriminator transformer to chassis (full discriminator load).

(c) Vacuum Tube Voltmeter from Limiter Grid to Chassis.

(d) Loosen Slugs by applying a hot iron to the cement.

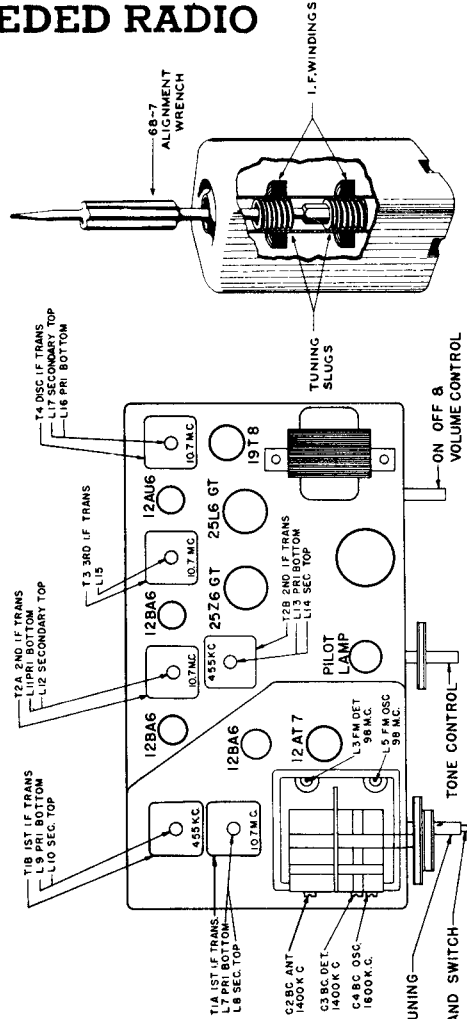

TUBE AND TRIMMER LOCATION
 Detail of IF Transformer

MANUAL OF 1951 MOST-OFTEN-NEEDED RADIO DIAGRAMS

ZENITH RADIO CORP. MODEL H880RZ, CHASSIS 8H20
 (Models H880R and H880R-revised are similar to Model H880RZ, but do not have radiation shielding).

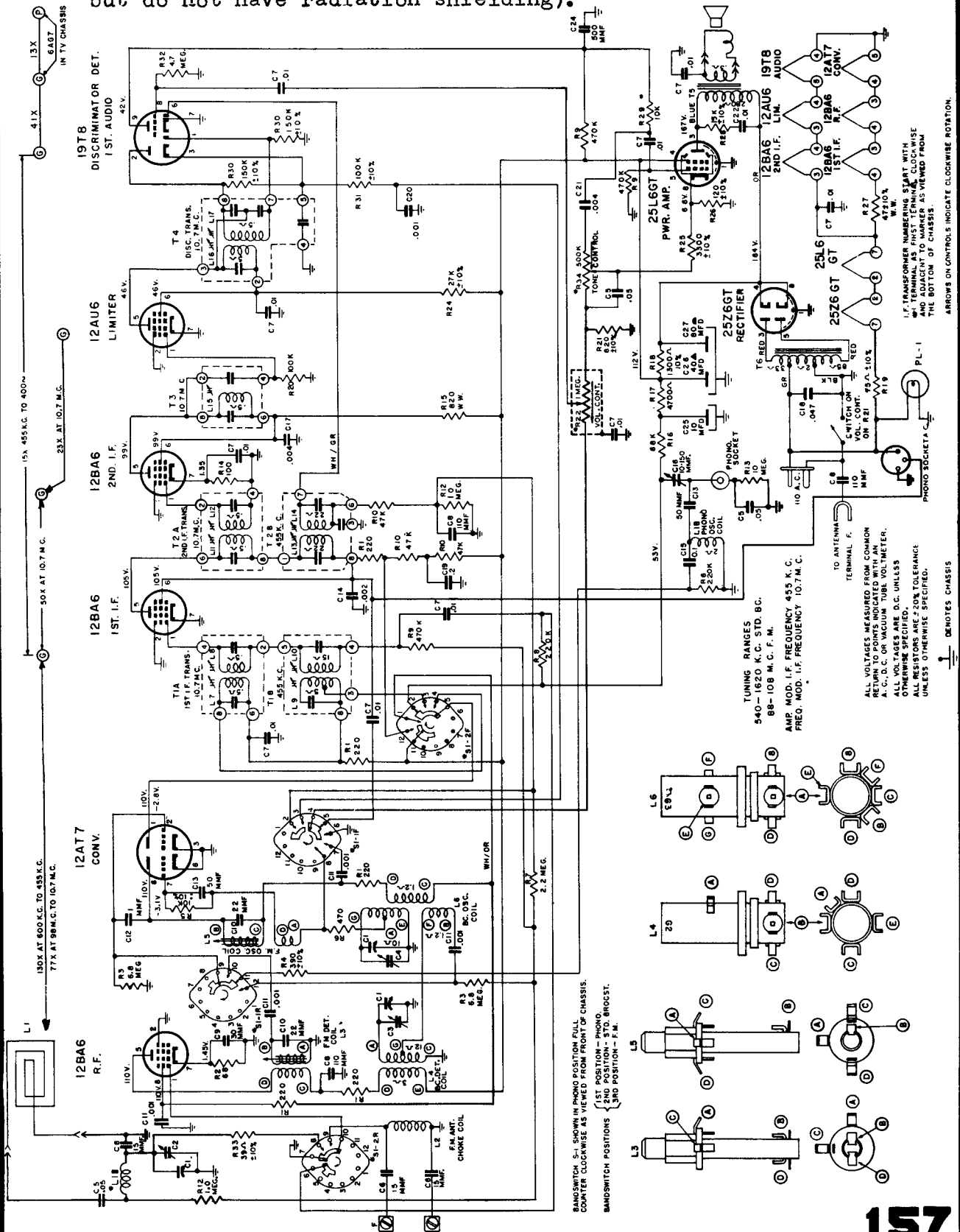

I.F. TRANSFORMER MARKETING START WITH PL-1 AND ADJACENT TO MARKER AS VIEWED FROM THE BOTTOM OF CHASSIS.

ARROWS ON CONTROLS INDICATE CLOCKWISE ROTATION.

TO ANTENNA F. TERMINAL F.
 ALL VOLTAGES MEASURED FROM COMMON RETURN TO POINTS INDICATED WITH AN A.-C. D.C. OR VACUUM TUBE VOLTMETER. ALL VOLTAGES ARE D.C. UNLESS OTHERWISE SPECIFIED. ALL RESISTANCE TOLERANCE UNLESS OTHERWISE SPECIFIED.

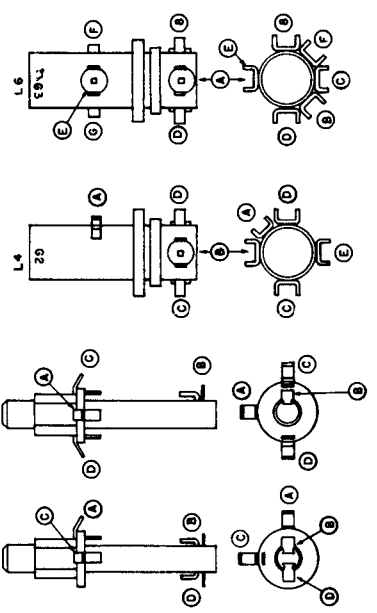

BANDSWITCH S-1 SHOWN IN PHONO POSITION FULL COUNTER CLOCKWISE AS VIEWED FROM FRONT OF CHASSIS.
 BANDSWITCH POSITIONS
 { 1ST POSITION - PHONO.
 2ND POSITION - STD. BROCAST.
 3RD POSITION - P.M.

MANUAL OF 1951 MOST-OFTEN-NEEDED RADIO DIAGRAMS

ZENITH RADIO CORP. MODELS H1083E, H1086R, H1087R, CHASSIS 10H20

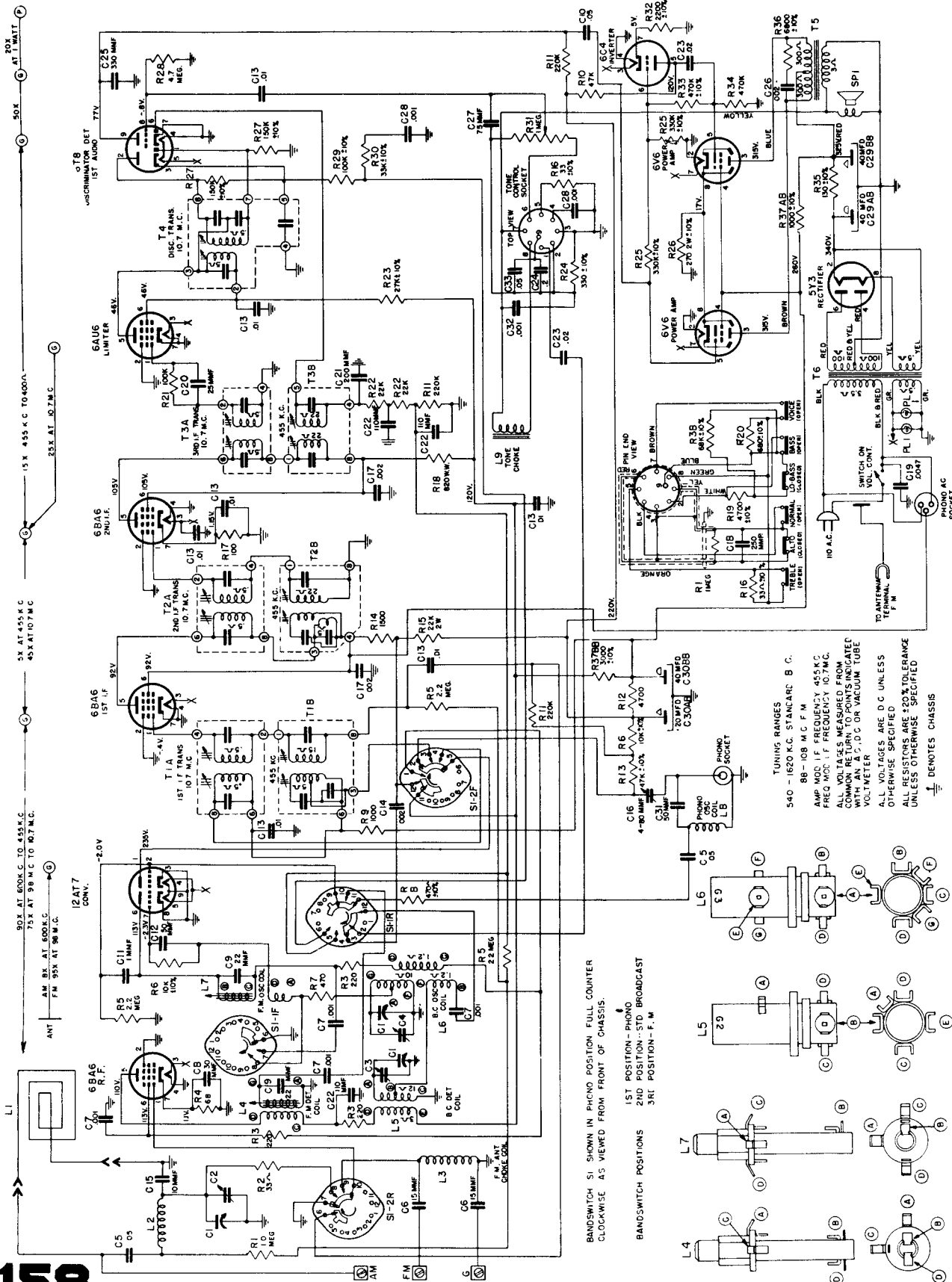

MANUAL OF 1951 MOST-OFTEN-NEEDED RADIO DIAGRAMS

ZENITH RADIO CORP.

COBRA-MATIC RECORD CHANGERS

MODELS S14028, S14029, S14030,

S14031 and S14036

The Zenith Models S-14028, S-14029, S-14030, S-14031 and S-14036 Record Changers are designed to play standard 78, 45 and 33 1/3 RPM records of standard commercial dimensions. With few minor exceptions these five changers are alike electrically.

Features of these changers include playing and automatically changing as many as ten 12" or ten 10" records. Ten inch and twelve inch records of the same type cannot be intermixed.

A full stack of 7" 33 1/3 RPM, or a full stack of 7" 45 RPM records (with adapter inserted in the records) can also be played on this changer. This changer does not shut off after the last record, however, all that is required to turn the changer off is to move the speed change lever (18) to OFF position.

LOADING THE RECORD CHANGER

1. Pull straight up on the record pressure arm knob (12) until the record pressure arm clears the spindle. Swing the record pressure arm to the right until pins in pressure arm shaft (14) drop into locating slot on record pressure arm housing (1).

2. Changer will automatically play ten 12" either standard or Long Play, ten 10" either standard or Long Play or ten 7" Long Play or Fine Groove records.

NOTE: Standard, Fine Groove and Long Play records cannot be played in the same stack of records. Speed change lever (18) must be re-set for each type of recording. (Continued on page 160).

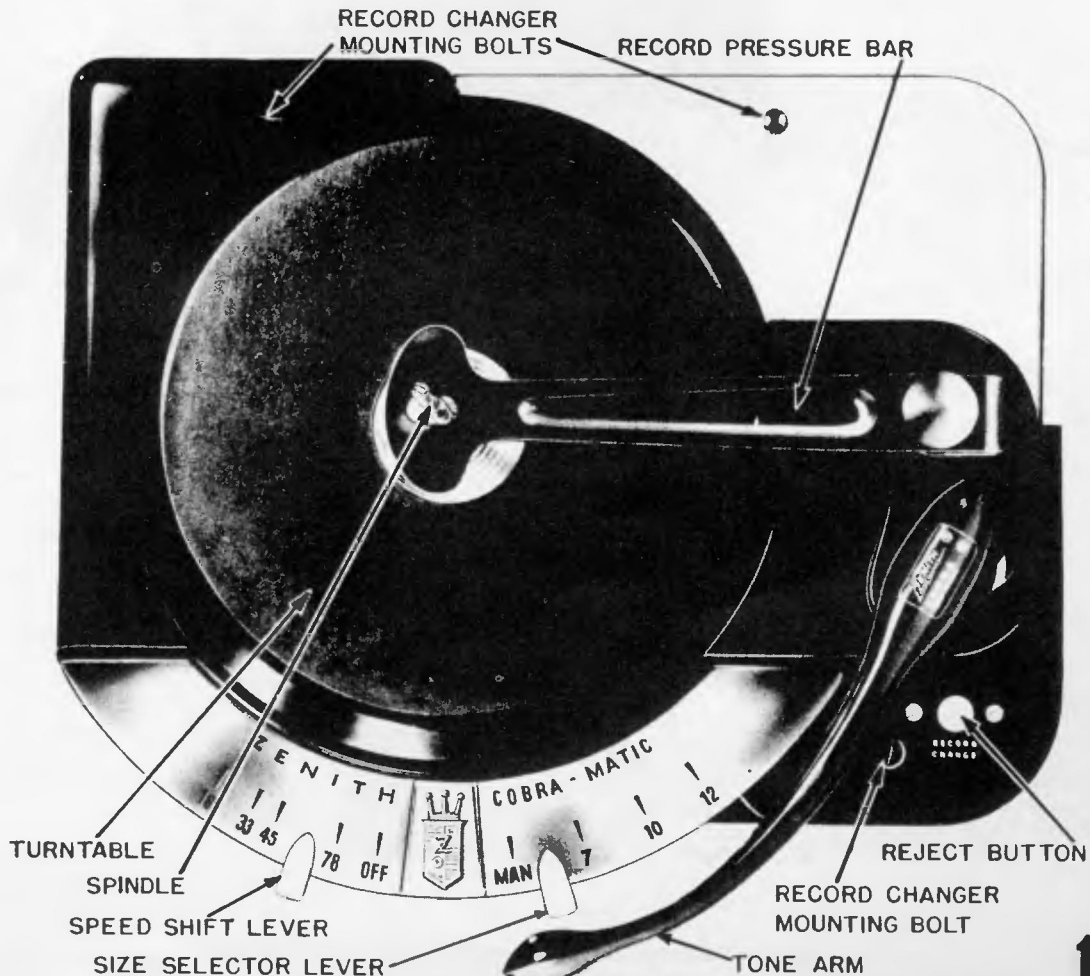

MANUAL OF 1951 MOST-OFTEN-NEEDED RADIO DIAGRAMS

ZENITH Record Changer, continued

3. Place records on spindle and lower them to offset shelf. Level records and replace record pressure arm (14) over spindle and lower this until it rests on the top of the record stack.

To play standard 78 RPM recordings:

1. Motor speed control lever (18) must be set to 78 position. This will set the record changer to proper speed position and cause the turntable to rotate.
2. Set-up lever (17) must be moved to the size records being played.
3. Place the changer in cycle by depressing reject switch knob (73). The changer will play the remaining records automatically. The changer will continue to play the last record until speed change lever (18) is moved to OFF position.

To play 33 1/3 RPM records:

1. Motor speed change lever (18) must be in 33 1/3 position.
2. Set-up lever (17) should then be moved to either 12", 10" or 7" position depending on the size record being played.

To play Fine Groove (45 RPM) records:

1. Speed change lever (18) should be moved to 45 position and set-up lever (17) should be in 7" position. It must be remembered that these records are manufactured with a 1 1/2" spindle hole so it is essential that a record adapter be inserted into each 45 RPM record to be played. This is necessary to reduce the spindle hole to conventional size.

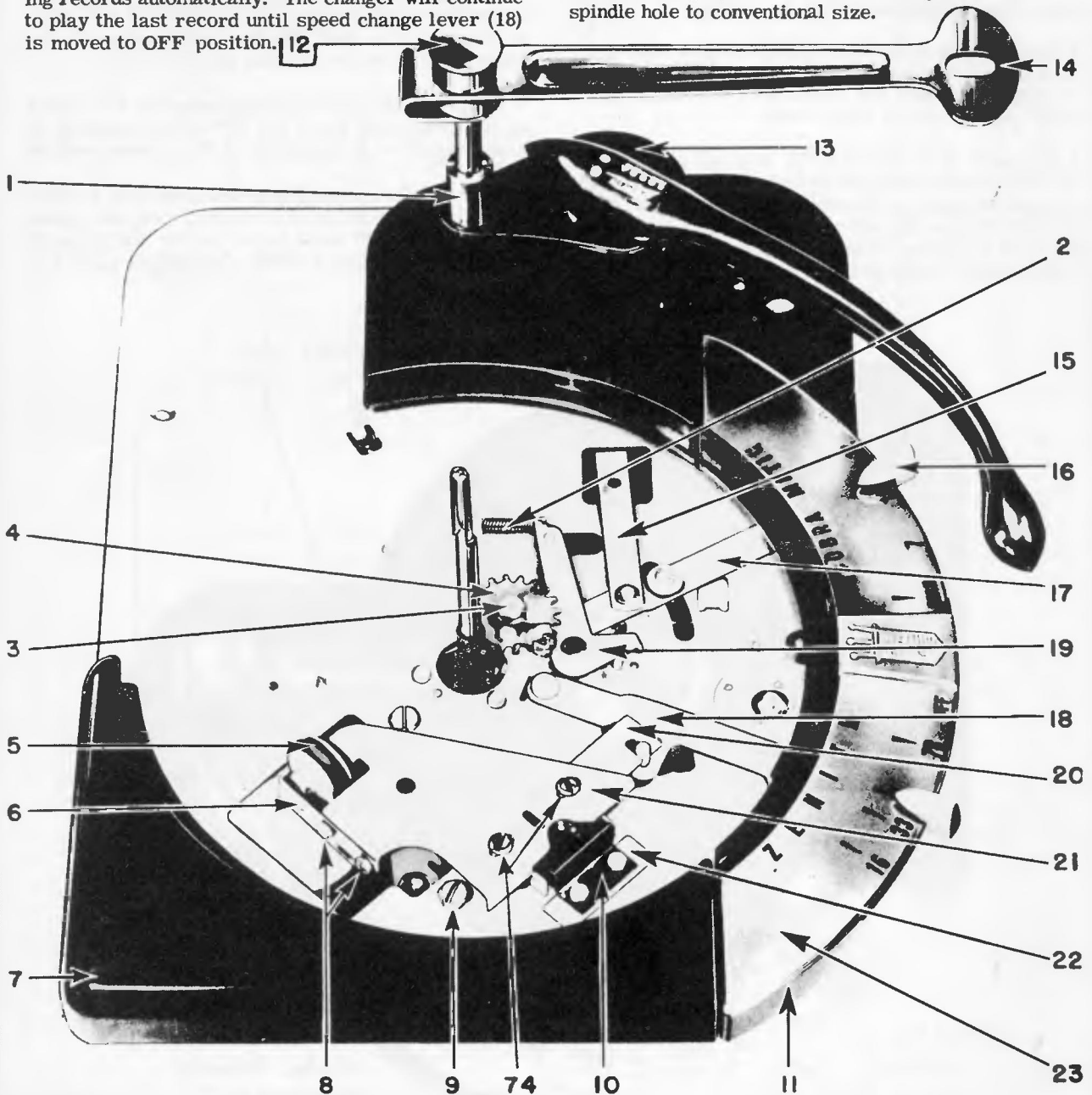

MANUAL OF 1951 MOST-OFTEN-NEEDED RADIO DIAGRAMS

REJECTING

To reject a record anytime, while the changer is operating, depress reject switch button (73) and release. This will automatically cause the record changer to go through cycle and begin playing the next record.

ZENITH Record Changer, continued

STOPPING

To turn off the record changer all that is required is to move the speed shift lever (18) to OFF position.

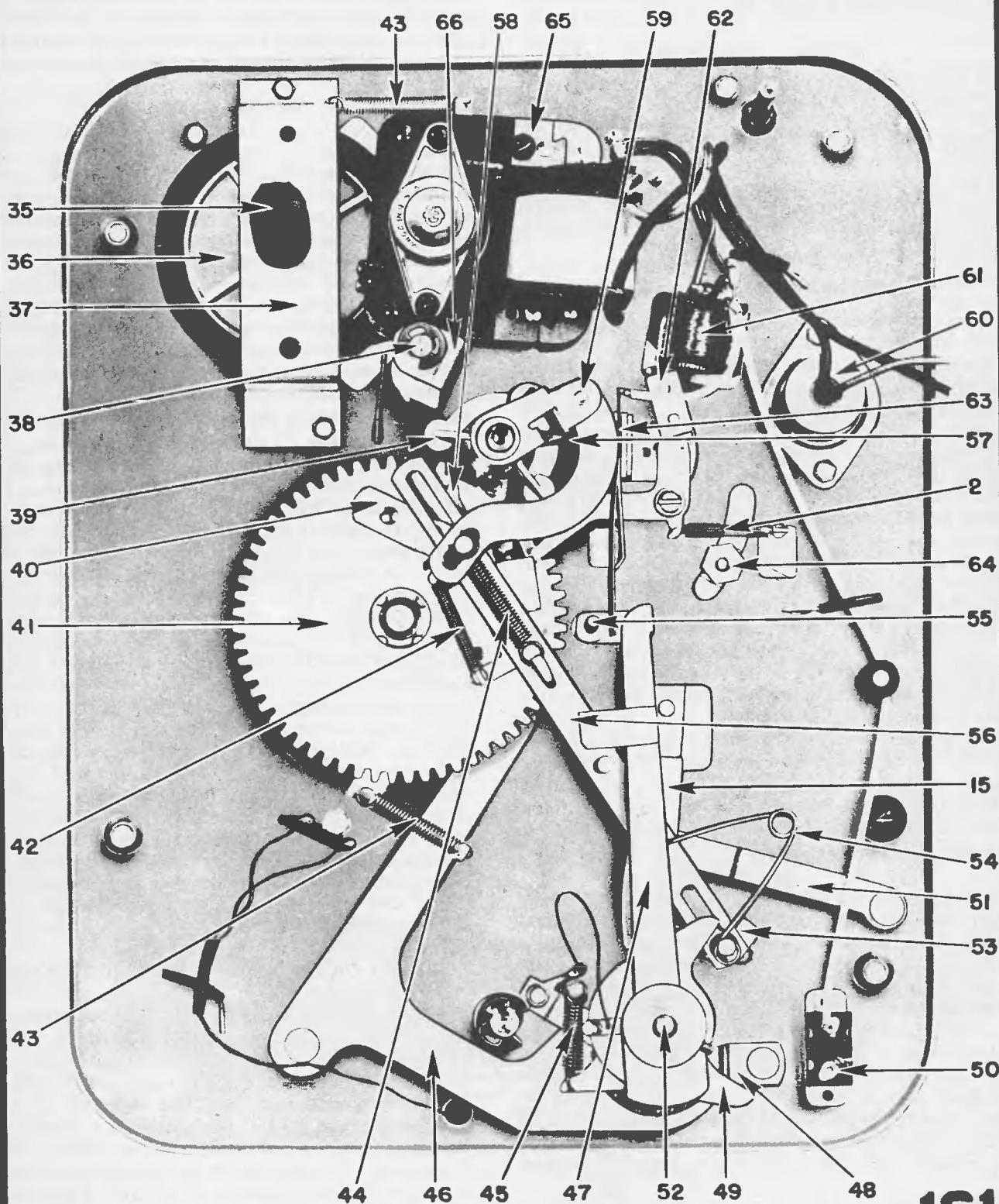

Record Changer Bottom View

MANUAL OF 1951 MOST-OFTEN-NEEDED RADIO DIAGRAMS

ZENITH Record Changer, continued

UNLOADING

Lift the record pressure arm (14) and swing it to the right until the pin on the shaft drops into the locating groove on record pressure arm shaft housing (1). Lift stack of records straight up on spindle.

MANUAL OPERATION

To play single records or home recordings, lift up the record pressure arm and turn it to the right. Place record on spindle and lower to the spindle shelf. Gently push record towards record pressure arm shaft and lower to turntable. Move speed change lever (18) to proper speed for type of record being played and move set-up lever (17) to manual position. Pick up tone arm and place the needle on the lead-in groove of the record.

DESCRIPTION OF CYCLING

The motor shaft contacts drive wheel assembly (36) and causes it to rotate by friction contact with its rubber surface. Drive wheel assembly (36) drives idler wheel (5). The underside of the turntable is in contact with idler wheel (5) and is driven in this manner. Speed of the turntable is controlled by changing the position of the idler wheel (5) on drive wheel (36). When idler wheel is moved to the center of drive wheel (36) it will rotate more slowly than when moved to the outer edge of this drive wheel (36). In this manner the turntable can be driven at any speed from 10 to 85 RPM. Minor adjustments for proper tonal pitch can be made by simply moving speed change lever (18) back and forth to compensate for turntable speed which may vary due to line voltage changes. When reject button (73) is depressed it energizes solenoid (61) which then attracts trip pawl assembly (62). The same thing occurs when the forward movement of the tone arm causes friction lever and weight assembly (47) to contact the copper bronze contact on trip switch assembly (63). When gear segment (58) is released, gear pawl spring (42) causes the gear segment (58) to engage the rotating pinion gear (25) under the turntable thus causing clutch assembly (41) to rotate.

As clutch assembly (41) rotates, tone arm lift lever (46) swings in such a manner that it contacts tone arm lift pin and raises the tone arm. Simultaneously, tone arm link and stud assembly (56) slides towards, and contacts one finger of tone arm lever assembly (49) forcing the tone arm towards the outer edge of the turntable and then on its return swing contacts the other finger of tone arm lever assembly (49) swinging the tone arm back over the records. The position to which it swings the tone arm over the records is determined by the position of record size discriminator (51). There are three steps on the record size discriminator (51) which determines set-down position

for 7", 10" and 12" records. The tone arm lift lever (46) returns and releases brake lever assembly (48) which keeps the tone arm from moving erratically during cycle. Simultaneously, ejector lever and link assembly (59) rotates and this in turn causes spindle shaft (30) to rotate and ejector cam (29) to push the record off the spindle shelf. Operation of the tone arm set-down adjustment can be observed by raising the tone arm so the adjustment mechanism can be viewed.

VELOCITY TRIP

This changer is provided with what is commonly known as a velocity trip rather than a ratchet and positive trip mechanism. A velocity trip depends for the tripping action on the rate of forward motion of the pickup arm with respect to the turntable rotation. The changer will trip only when the tone arm advances more in one revolution of the turntable than the distance between normal grooves in a record. Only records having fast finishing grooves will operate the velocity trip. During the normal playing cycle, friction lever and weight assembly (47) continually moves forward toward the copper bronze contact on trip switch assembly (63).

On normal forward advance, the friction lever and weight assembly (47) is kept from contacting the copper bronze contact by a wiping action from oscillating lever stud assembly (55). The oscillation of oscillating lever and stud assembly is produced by eccentric motion of oscillating gear (4) which is driven by the pinion gear (25) on the lower portion of the turntable. Oscillating gear (4) is mounted off-center so it will describe an eccentric action as it is being driven by the turntable gear. The tone arm moves in towards the center of the record and the repeated action of oscillating lever (55) keeps friction lever and weight assembly (47) from coming in contact with the copper bronze strip on trip switch assembly (63) as the pickup arm moves slowly towards the spindle and lead-in grooves. During the first revolution of the turntable, in the eccentric cycling grooves, the pickup arm advances rapidly and friction lever and weight assembly (47) is moved forward fast enough so that oscillating lever (55) does not halt its progress, therefore, friction lever and weight assembly (47) contacts the copper bronze trip contact on trip switch assembly (63) grounding it and making a complete circuit. This actuates solenoid (61) causing the changer to cycle.

THEORY OF THE COBRA RADIONIC PICKUP

The operation of the Cobra pickup is considerably different from Crystal and Dynamic pickups. These pickups generate audio power, while the Cobra controls power generated by a radio frequency oscillator, detector and audio amplifier. The oscillator operates at a frequency of 2.5 Mc. Modulation is accomplished by changing the energy losses in a tuned circuit. These losses may be represented by an equivalent resistance in series with the reactance of the coil. The ratio of the resistance to the reactance determines the effi-

MANUAL OF 1951 MOST-OFTEN-NEEDED RADIO DIAGRAMS

ciency or Q of the coil. The amplitude of the RF voltage developed across this coil by an oscillator will vary with changes in Q .

The grid coil $L1$ and other components of the oscillator are mounted in the oscillator pre-amp chassis, while the plate coil $L2$ is in the needle cartridge with vane and needle assembly. The coil is fixed and has 40 turns of No. 40 wire (approximate DC resistance 2 1/2 ohms). The stainless steel vane, which is in the field of the coil, is spot welded to the osmium-iridium tipped stylus.

Any movement of the stylus will cause a corresponding movement of the vane. As the stylus and vane follow the modulations in the record, changes in the mutual inductance between the vane and coil occur. In position 2 the vane is at rest, and a constant RF voltage appears across the plate coil. As the vane is set in motion and reaches position 1, it is at its greatest outward swing from the coil, resulting in low mutual inductance, low reflected resistance, higher Q , and a higher RF voltage across the coil. In position 3 it is at its greatest inward swing, resulting in a high mutual inductance, high reflected resistance, lower Q and a

ZENITH Record Changer, continued

lower RF voltage. It can be seen that the amplitude of the RF voltage which appears across the coil will vary with changes in Q , satisfying the condition for amplitude modulation. The position of the vane changes both the Q and L of the coil. Changes in L shift the frequency slightly, and a certain amount of frequency modulation is present, but since there is no frequency discrimination it remains undetected. Since the grid and plate coils are part of a single tuned circuit, any variations of amplitude of the RF voltage brought about by the changes in Q across the plate coil will also appear across the grid of coil $L1$, causing a shift in the average plate current through the plate load resistor across which the audio output voltage is developed. Plate bend detection takes place since only the positive half of the grid swing causes an increase in the average plate current. These changes in the average plate current appear as audio voltage across the plate load resistor.

The 2.5 Mc RF voltage and the audio voltage both appear at the plate (pin 6) of the oscillator triode. $R2$, $C4$ and $C5$ filter out the RF voltage allowing only the audio component to the grid (pin 4) of the amplifier triode where it is amplified, fed through a shielded lead to the audio amplifier of the receiver and reproduced by the loud speaker.

SET DOWN ADJUSTMENT

When adjusting the tone arm for proper set-down on the edge of the record, move set-up change lever to 7" position, place a 7" record on the turntable, turn the record changer through cycle by rotating the turntable by hand. Watch closely where the needle point of the Cobra cartridge lands on the record and adjust tone arm set-down adjustment screw (33) until proper landing position is obtained.

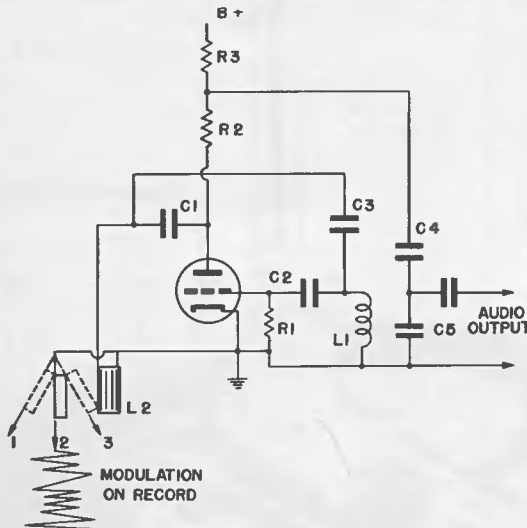

Simplified Circuit of Oscillator

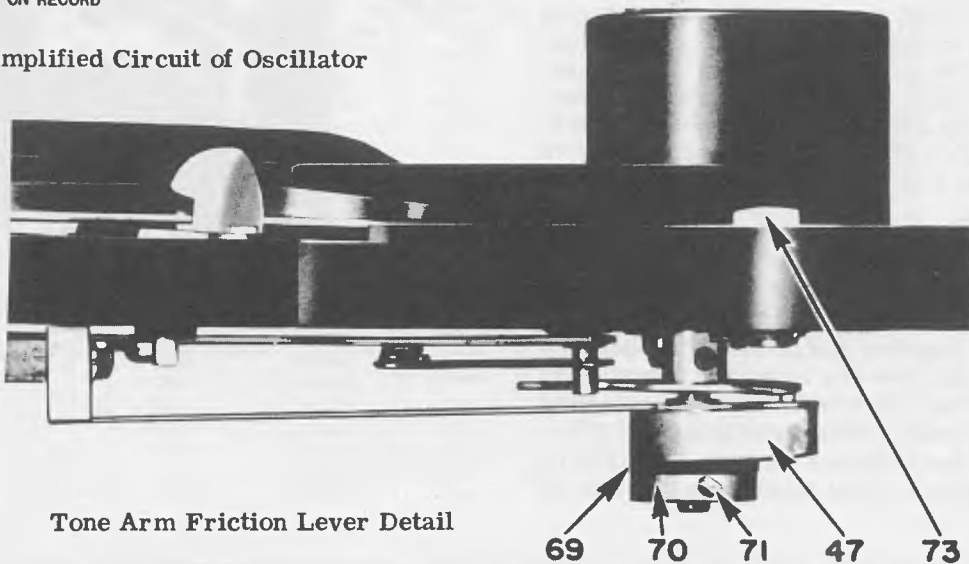

Tone Arm Friction Lever Detail

MANUAL OF 1951 MOST-OFTEN-NEEDED RADIO DIAGRAMS

ZENITH Record Changer, continued

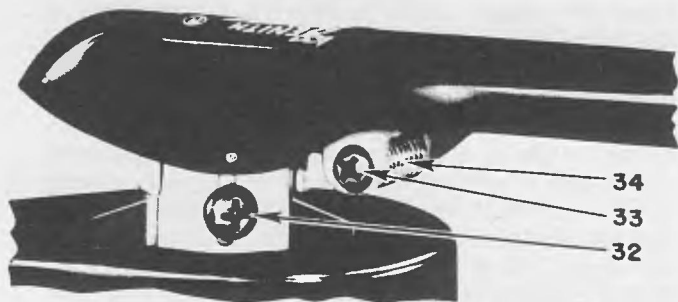

Tone Arm Set-Down & Height Adjustments

TONE ARM HEIGHT ADJUSTMENT

The tone arm height adjustment determines vertical rise of the tone arm. If the tone arm does not rise sufficiently it will not play a full stack of twelve records. On the other hand, if the tone arm raises too high it may hit the records resting on the record shelf. Set the tone arm height adjustment screw (32) so that the needle clears twelve unwarped records on the turntable. The tone arm housing must not hit the under side of the records on the record shelf when the changer is cycled after adjustment.

SLAB HEAD SCREWS

For maximum rigidity many components are locked into position with slab head screws. This type set screw provides a more positive grip. The slab head set screw wrench is available as part number 68-8.

SPEED INDICATOR ADJUSTMENT

It is possible that the speed of the record changer may not conform to the speed stop on escutcheon (23). Proper adjustments can be made in the following manner. Put a stroboscopic disc on the turntable, adjust speed change lever (18) until the turntable is turning at exactly 78 RPM. Stop the record changer by pulling the AC plug, remove the turntable, loosen the two adjusting screws (74) and move speed change lever (18) so that the point on the control knob indexes exactly at the 78 mark on the escutcheon (23). Then re-tighten adjusting screws (74) and replace the turntable. The turntable should now rotate at exactly 78 RPM, however, as a precaution, again check with the stroboscopic disc.

SPINDLE

The spindle on this record changer is composed of five separate parts: Spindle shaft (30) and ejector cam (29) are pressure-fit together and if either breaks, they cannot be replaced since the assembly operation is a machine operation. The spindle housing is composed of two separate portions which once again are pressure-fit together and require a machine operation for assembly. It is possible that spindle cap (31) may be

pulled off spindle assembly (72) and if this does occur, it can easily be replaced by sliding a new spindle cap down over the spindle and then pressing in on the dent portion, which acts as a stop to keep the spindle cap from sliding off spindle (72). If breakage occurs other than loss of the spindle cap (31), the entire spindle assembly (72) must be replaced.

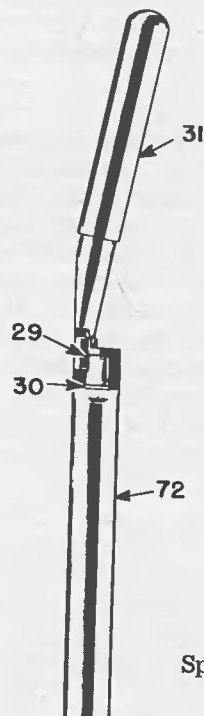

Spindle S-17424

