

Most - Often - Needed

1955

Volume 15

RADIO
DIAGRAMS
and Servicing Information



Supreme Publications

Copyright 1955 by Supreme Publications.

MANUAL OF 1955 MOST-OFTEN-NEEDED RADIO DIAGRAMS

Index

Admiral Corp.

3G18	7
4Z1	6-7
4Z11	6
4Z12	6
4Z14	6
4Z18	6
4Z19	6
5K3	5
5K31	5
5K32	5
5K34	5
5K38	5
5K39	5
5R3	8-10
5R32	8
5R33	8
5R35	8
5R35 to 5R38	8
5S3	8-10
5S32	8
5S33	8
5S34	8
5S35	8
5S38	8
5T3	8-10
5T31	8
5T32	8
5T33	8
5T34	8
5T38	8
361	7

Arvin Industries

RE-278-1	11
RE-369	12
RE-372	15
RE-374	16
RE-375	13
RE-377	14
RE-378	16
RE-381	15
840T	11
842T	11
848T	12
848T	12
850T	13
851T	14
852P	15
853T	13
854P	15
855T	14
857T	16
858T	16
859T	16

Bendix

5BF	17
5BH	18
5BM	18
R5BF	17
R5BLA	18
R5BLB	18
R5BM	18
FDH-18805-B1	17
FDL-18805-B,- -C,-D,	18

Cadillac

7265825	106
7265845	106

Capehart-

<u>Farnsworth</u>	
1P55	20
2T55	21
3T55	21
4PH55B,-M	22
6TP45M	22
C-14	19
16PH55B,-F	22
16PH55M	22
CR-93	19
CR-148	20
CR-150	21
CR-154	21
CA-156	22
CA-161	22

Chevrolet

987087	100
987088	102

CBS-Columbia

5T3	23
5155	23
5156	23

Delco, see United Motors

DeWald Radio

J-540	23
J-541	23

Emerson Radio

808B	24
810B	24
811B	25
812B	25
813B	25
814B	27
819B	28
820B	28

Emerson (Cont.)

822B	25
825B	29
826B	29
830B	30
120189B	24
120222B	24
120228B	25
120229B	25
120230B	25
120231B	27
120232B	25
120240B	28
120243B	29
120252B	30

Ford Motor Car

5BF	17
5MF	51
5MF8	53
R5BF	17
FDH-18805-A2	53
FDH-18805-B1	17
FDH-18805-B2	51

General-Electric

446	31
447	31
448	31
455	32
577	33
578	33
580	34
581	34
582	34
590	35
635	36
636	36
637	36
645	37
646	37
647	37
648	37
660	38
661	38

Hallicrafters

5R24	41
5R40	42
5R41	42
5R42	42
5R60	40
5R61	40
B-55	39
TW-55	39

Lincoln

FDL-18805-B,- -C,-D	18
------------------------	----

Majestic Radio

4L1	43
5M1	43

Mercury

FDL-18805-B,- -C,-D	18
------------------------	----

Montgomery-Ward

GSL-1614A	44
GSL-1615A	44
GSL-1616A	44
GSL-1617A	44

Motorola, Inc.

5MF	51-52
5MF8	53
34F1	48
34F1C	48
54HF1	47
54HF1B	47
54X1	45
54X2	45
54X3	45
55A1	49
55A2	49
55A3	49
55C1	50
55C2	50
55C3	50
55C4	50
64X1	46
64X2	46
395	54-55
395-12	54
HS-422	49
HS-432	45
HS-440	46
HS-443	47
HS-444	48
HS-456	50
HS-467	48
613	56
614	56
833	57-58
834	57-58
836	57-58
900	59-60
901	59-60
FDH-18805-A2	53
FDH-18805-B2	51

Olympic Radio

401	61
441	62
442	63
HF-500	64
571	64
573	64

MANUAL OF 1955 MOST-OFTEN-NEEDED RADIO DIAGRAMS

<u>Packard-Bell</u>		<u>RCA (Continued)</u>	<u>Sylvania, Cont.</u>	<u>Westinghouse +</u>
541	65	5BX41	614	H-490P4
543	65	5C581	918	H-491P4
		5C591	5484	H-492P4
		5C592		H-493P4
<u>Philco Corp.</u>		5C592		H-494P4
C-579	66	6BX5		H-495P4
C-580	66	6BX6	<u>Trav-ler Radio</u>	H-496P4
C-583	67	6RF9	55-37	H-499T5A
C-584	67	6XF9	55-38	H-500T5A
C-661	68	RS-145A	55-39	H-504P4
C-662	68	RC-1121B	521R90	H-505P4
C-663	69	RC-1129A	521R91	H-506P4
C-667	70	RC-1130	5510	H-507P4
C-716	66	RC-1134		H-508P4
C-718	66	RC-1141	<u>Truetone, see</u>	V-2184-4
C-720	66	RC-1141A	<u>Western Auto</u>	V-2185-2
C-721	67	RC-1142		V-2189-4
C-722	67	RC-1144	<u>United Motors</u>	V-2229-1
C-723	67	RC-1145	984961	V-2229-2,-3
C-724	67	RC-1146	987087	V-2234-1
C-1334	71	RC-1147	987088	V-2236-1,-2
C-1340	71	RC-1148	7265825	V-2237-1
C-1341	71	RC-1148A	7265845	V-2238-1
C-1342	71	RC-1149		
C-1343	71		<u>Western Auto</u>	
C-1347	71	<u>Sears, Roebuck</u>	D-2562A	<u>Zenith Radio</u>
C-1348	72	5036	D-2563A	4T-42
C-1755	71	5042	D-3503A	5M-02Z1
		5045	D-3504A	5R-01
<u>Pontiac</u>		5046	D-4425B	5R-03
984961	104	528.32400	D-4426B	5R-05
		528.32500		5R-07
		528.34900	<u>Westinghouse El.</u>	5R-10
<u>RCA-Victor</u>			H-443T5	5R-20
3-HS-61	73	<u>Sentinel Radio</u>	H-444T5,-A	6R-03
3-US-5	74	1U-353	H-445T5,-A	8T-01
3-US-5A	74	353	H-446T5,-A	126-127
4C531	76	IU-357	H-447T4	HFR-20E
4C532	76	IU-358	H-448T4	HFR-21R
4C533	76		H-449T4	T-402F,-V,-Y
4C534	76	<u>Stromberg-</u>	H-457T6	128
4C535	76	<u>Carlson</u>	H-458T6	R-509F,-R
4C541	76-77	EP-2	H-459T6	R-509V,-W,-Y
4C542	76-77	C-3	H-460T6	121
4C543	76-77	T-4	H-465R6	121
4C544	76-77	C-5	H-466R6	R-510Z1
4C545	76-77		H-467R6	R-511F,-R
4C547	76-77	<u>Sylvania Elect.</u>	H-468R6	R-511V,-W
4C671	75	1-602-4	H-475T5	R-512F,-R
4C672	75	1-602-5	H-476T5	R-512V,-W
4X551	76	1-602-6	H-477T5	R-519R,-W
4X552	76	1-602-7	H-478T5	R-521F,-G
4X553	76	1-605-1	H-486T5	R-521R,W,Y
4X554	76	518	H-487T5	T-522F,-G
4X555	76	548	H-488T5	T-522R,V,W
4X661	78	598	H-489T5	R-623,-F
4Y511	79			R-623R,W,Y
				T-825F,G,R

1955 MOST-OFTEN-NEEDED RADIO DIAGRAMS

Admiral

CHASSIS 5K3
MODELS 5K31, 5K32, 5K34, 5K38, 5K39

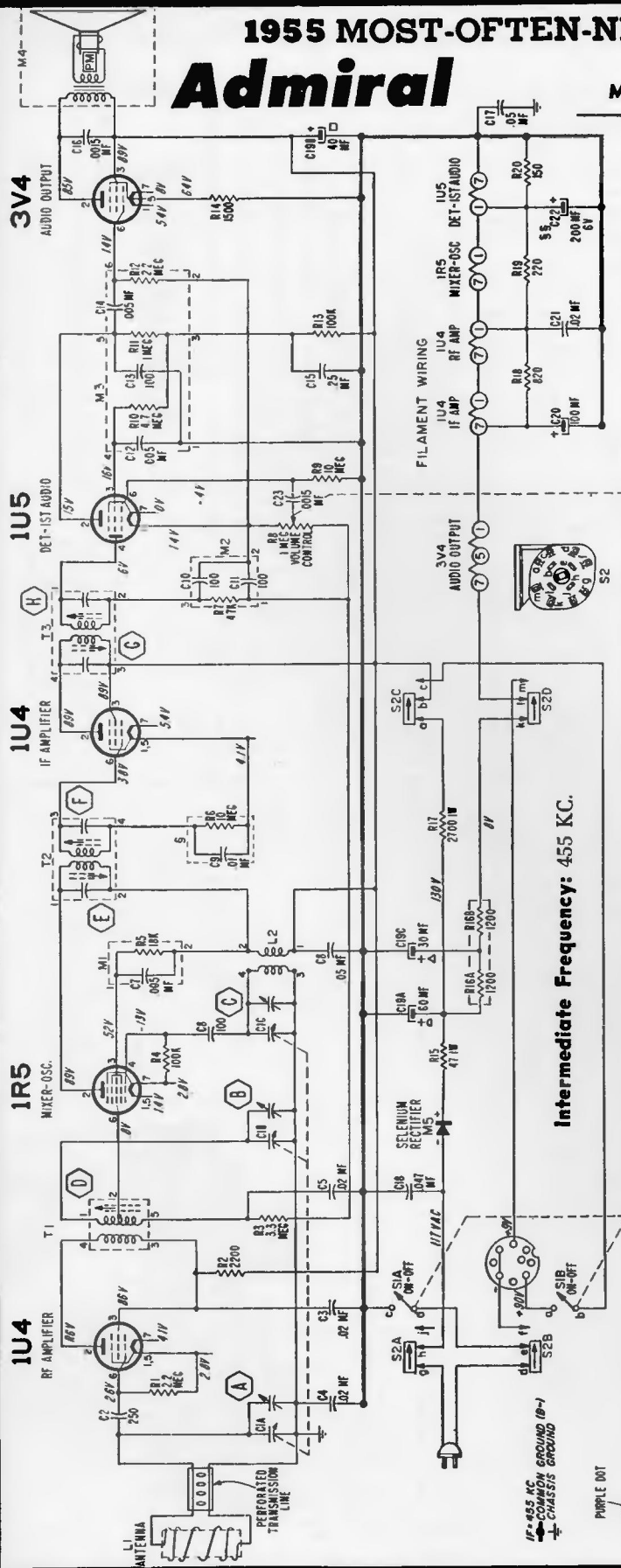

NOTE: S2 SHOWN IN AC POSITION. ALL VOLTAGE READINGS TAKEN WITH A VACUUM TUBE VOLTMETER.

A, ETC., INDICATE ALIGNMENT POINTS
S IN EARLY MODELS. C0 AND R6 WERE A COMPLETE. REPLACE COMPLETE WITH INDIVIDUAL COMPONENTS.
S S IN EARLY MODELS. C22 WAS .1 MF. 200 VOLT PAPER. REPLACE WITH 200 MF. 6 VOLT ELECTROLYTIC CAPACITOR.

Voltages shown on schematic diagram.

All voltages taken between tube socket terminals and B— (pin 7 of 1U5 tube).

Dial set at low frequency end; volume control at minimum.

Voltages measured with a vacuum-tube voltmeter, using 117 volts AC.

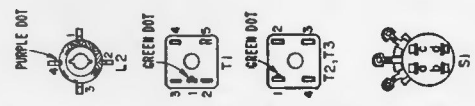

TUBE AND ADJUSTMENT LOCATIONS

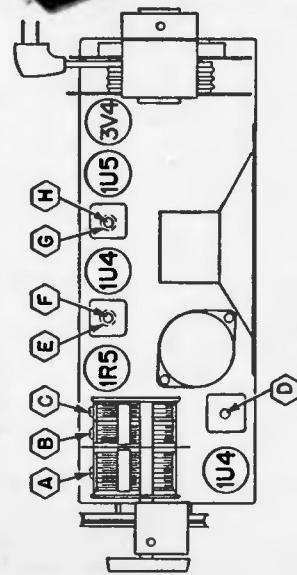

Adjustments E and G are made from underside of chassis

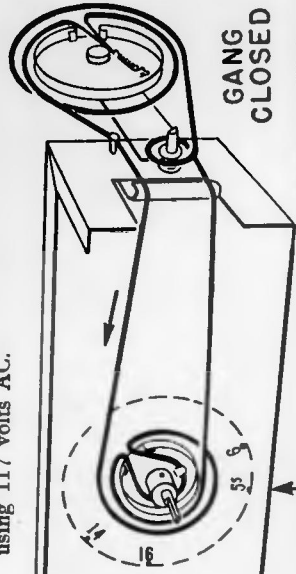

1955 MOST-OFTEN-NEEDED RADIO DIAGRAMS

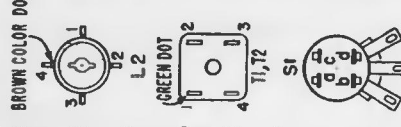
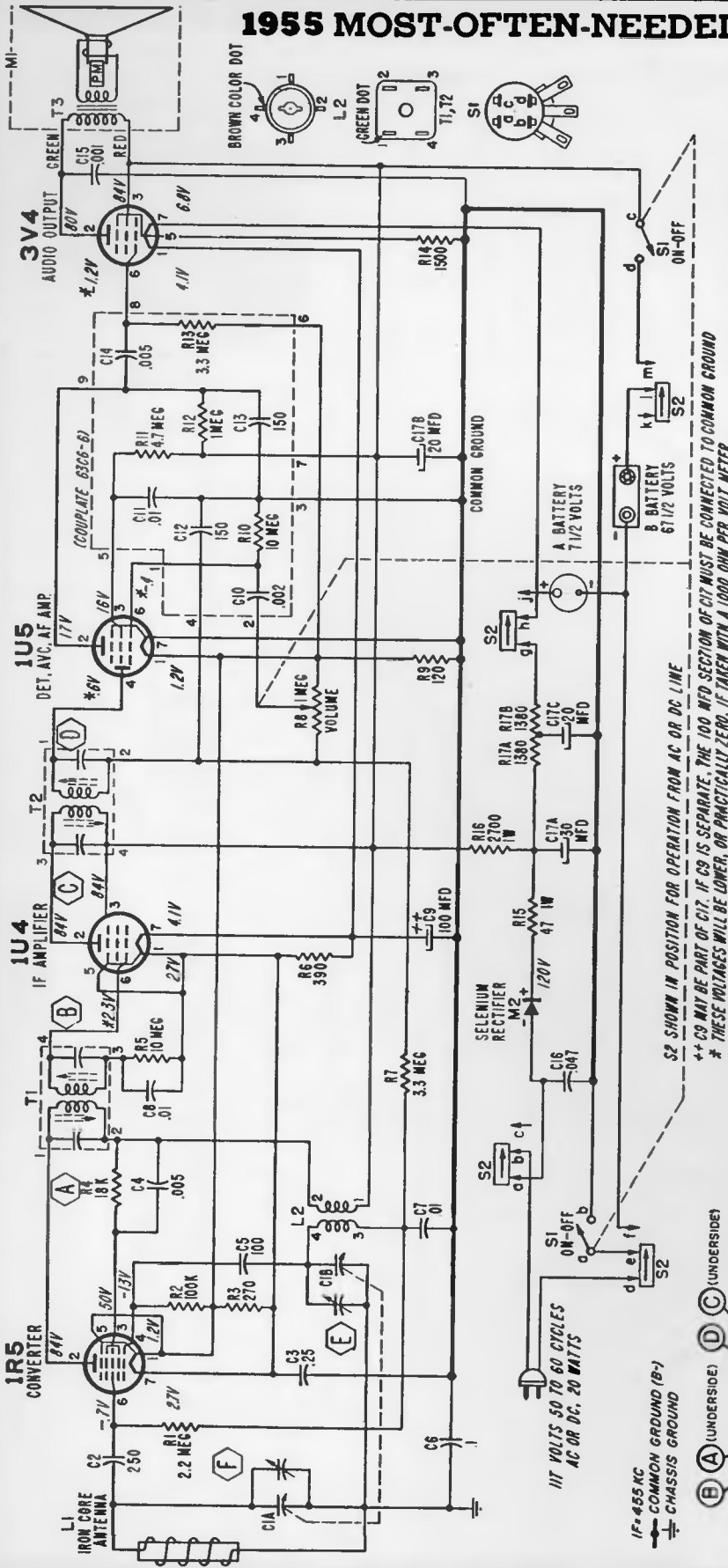

VOLTAGE DATA

Voltages shown on schematic diagram.
 All voltages taken between tube socket terminals and B minus (pin 7 of 1U5 tube).
 Dial set at low frequency end; volume control at minimum.
 Voltages measured on 117 volts AC with vacuum-tube voltmeter.

ALTERNATE AUDIO COUPLING SYSTEM

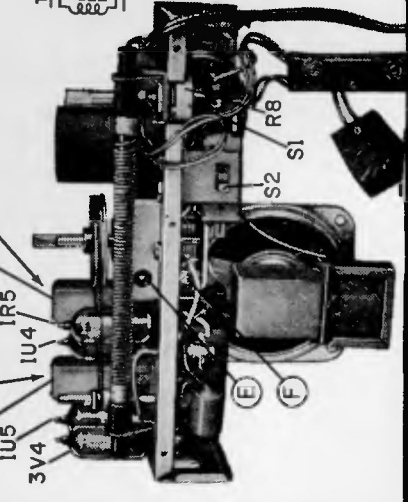
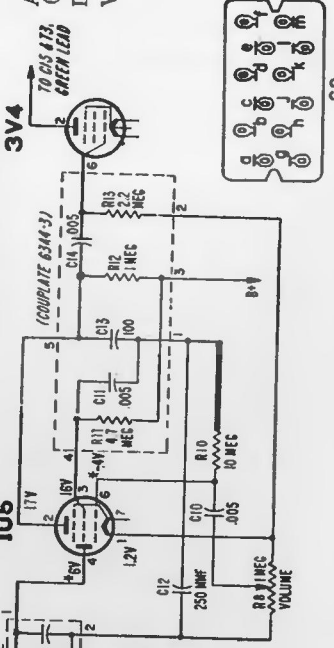

Admiral
 MODELS 4Z11, 4Z12, 4Z14, 4Z18, 4Z19
 CHASSIS 4Z1
 (Alignment on page 7)

MANUAL OF 1955 MOST-OFTEN-NEEDED RADIO DIAGRAMS

Admiral

(Continued from page 6)

CHASSIS 4Z1
MODELS 4Z11, 4Z12, 4Z14, 4Z18, 4Z19

ALIGNMENT PROCEDURE

- Battery power is preferable for alignment; use FRESH batteries. If this set is to be aligned while operating on an AC power line, an isolation transformer should be used. If an isolation transformer is not available, connect a .1 mfd. capacitor in series with the signal generator low side to B minus (pin 7 of 1U5 tube.)
- The chassis cover must be removed to align adjustments A and C.
- Set Volume control full on.
- Connect output meter across speaker voice coil.
- Use lowest setting of signal generator capable of producing adequate indication on lowest scale of output meter.
- Use a non-metallic alignment tool for IF transformers.
- Repeat adjustments to insure good results.

Step	Dummy Antenna in Series with Signal Generator	Connection of Signal Generator (High Side)	Signal Generator Frequency	Receiver Gang Setting	Adjustment Description	Adjustment Designation	Type of Adjustment
1	.1 mfd. capacitor	Stator of antenna tuning capacitor	455 KC	Gang fully open	2nd IF 1st IF	A, B* C, D*	Maximum output
2	.1 mfd. capacitor	Stator of antenna tuning capacitor	1620 KC	Gang fully open	Oscillator (on gang)	E	Maximum output
Install the metal chassis cover removed during IF Alignment.							
3	Loop of several turns of wire, or place generator lead close to receiver lead close to receiver for adequate signal pickup.	No actual connection (signal by radiation)	1400 KC	Tune in generator signal	Antenna (on gang)	F	Maximum output

*Adjustments B and D are made from underside of chassis. To avoid splitting the slotted head of powdered iron tuning slug in IF transformers, use an alignment tool with a blade 3/32" wide.

Admiral

Chassis 361
Model 3G18

ALL VOLTAGE READINGS TAKEN WITH A VACUUM TUBE VOLTMETER.

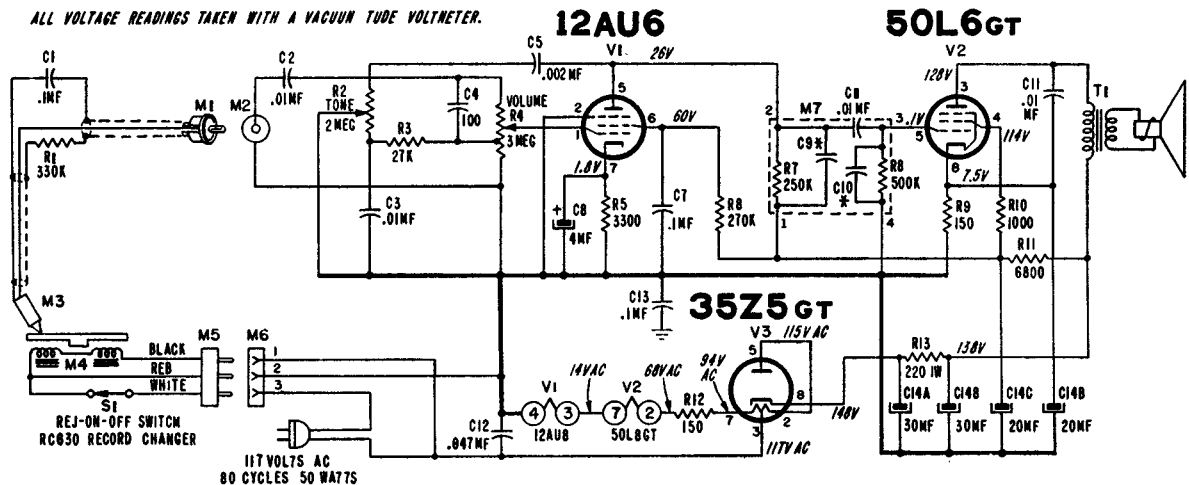

*C9 & C10 TOTAL 250NF. WHEN REPLACING WITH INDIVIDUAL COMPONENTS, USE ANY COMBINATION TOTALING 250NF OR USE 250NF ACROSS RT IN PLACE OF C9 AND C10.

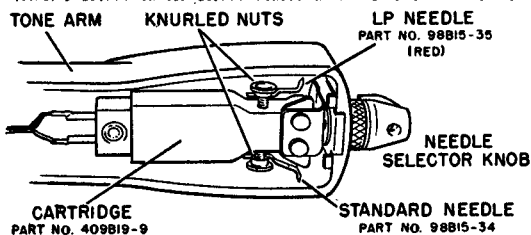

Bottom View of Cartridge and Needles.

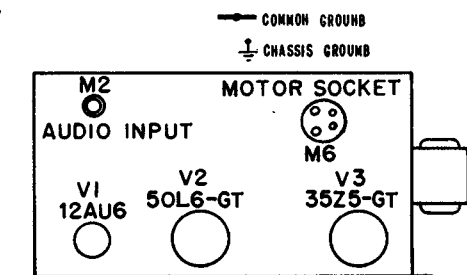

Side View of Chassis.

MANUAL OF 1955 MOST-OFTEN-NEEDED RADIO DIAGRAMS

Admiral

5R3 Chassis Models 5R32 • 5R33 • 5R35 • 5R36 • 5R37 • 5R38

5S3 Radio Chassis Models 5S32 • 5S33 • 5S34 • 5S35 • 5S38

5T3 Radio Chassis Models 5T31 • 5T32 • 5T33 • 5T34 • 5T38

This material applies to all models listed above. The circuit on page 9 is exact for Chassis 5R3 and 5T3. Chassis 5S3 circuit is exactly the same except for clock and associated switch. Alignment information and additional service data on page 10.

GENERAL

This receiver employs the latest radio circuitry and a "printed" circuit wiring technique. The "printed" circuit wiring used in this receiver replaces the hookup wire used in earlier receivers; see figure 1. The "printed" circuit wiring is permanently bonded to the underside of the plastic chassis base. This results in uniformity of chassis wiring, fewer wiring troubles and simplified circuit tracing and trouble shooting. All circuit components are of standard size and design and are mounted on the top side of the chassis; see figure 2. Audio circuit components are contained in a couplate.

Trouble shooting and parts replacement will, in general, be the same as for receivers wired with hookup wire. However, when servicing, it is important to read the service information given in this manual with respect to the technique of servicing printed circuit receivers.

SERVICING THE SET

Servicing "printed" circuit sets is, in general, much the same as servicing ordinary receivers. However, certain tools and techniques are well suited for this type of work. The following items are especially useful:

1. Good pair of long-nose pliers.
2. Sharp wire cutters.
3. Small stiff glue brush (for solder removal).
4. Pencil type soldering iron with a small tip (35 watts or less).

WARNING: Excessive heat may damage the "printed" circuit during component replacement if a soldering pencil, iron or gun of higher wattage rating is used.

5. 60-40 low temperature rosin core solder (should be used for all soldering).

6. Tinned jumper wires.

7. Metal pick (soldering aid).

COMPONENT REPLACEMENT

All components used in this receiver are of standard size and design and are mounted on the top side of the chassis; see figure 2.

Resistors and capacitors should be replaced by clipping out the defective part and neatly soldering the new part to the connecting leads remaining from the original part.

If a unit, such as the oscillator coil or IF transformer is to be removed, heat the mounting lugs with a pencil type soldering iron and straighten them with a long nose pliers or metal pick. Continue heating the lugs and brush away the molten solder with a small stiff glue brush. Remove the defective unit by lifting it off the chassis. Before inserting the new unit, be certain that the lug holes are open and free from solder. Forcing a lug against a solder filled lug hole may break the bond between the chassis base and the "printed" wiring. It is, therefore, necessary to exercise care when replacing units.

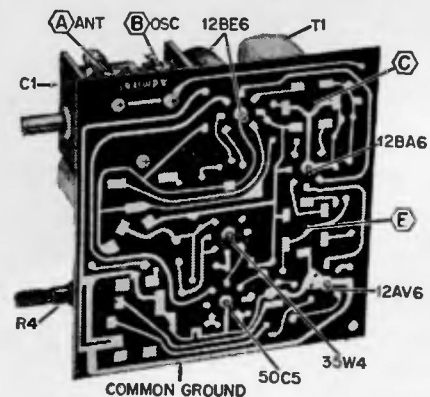
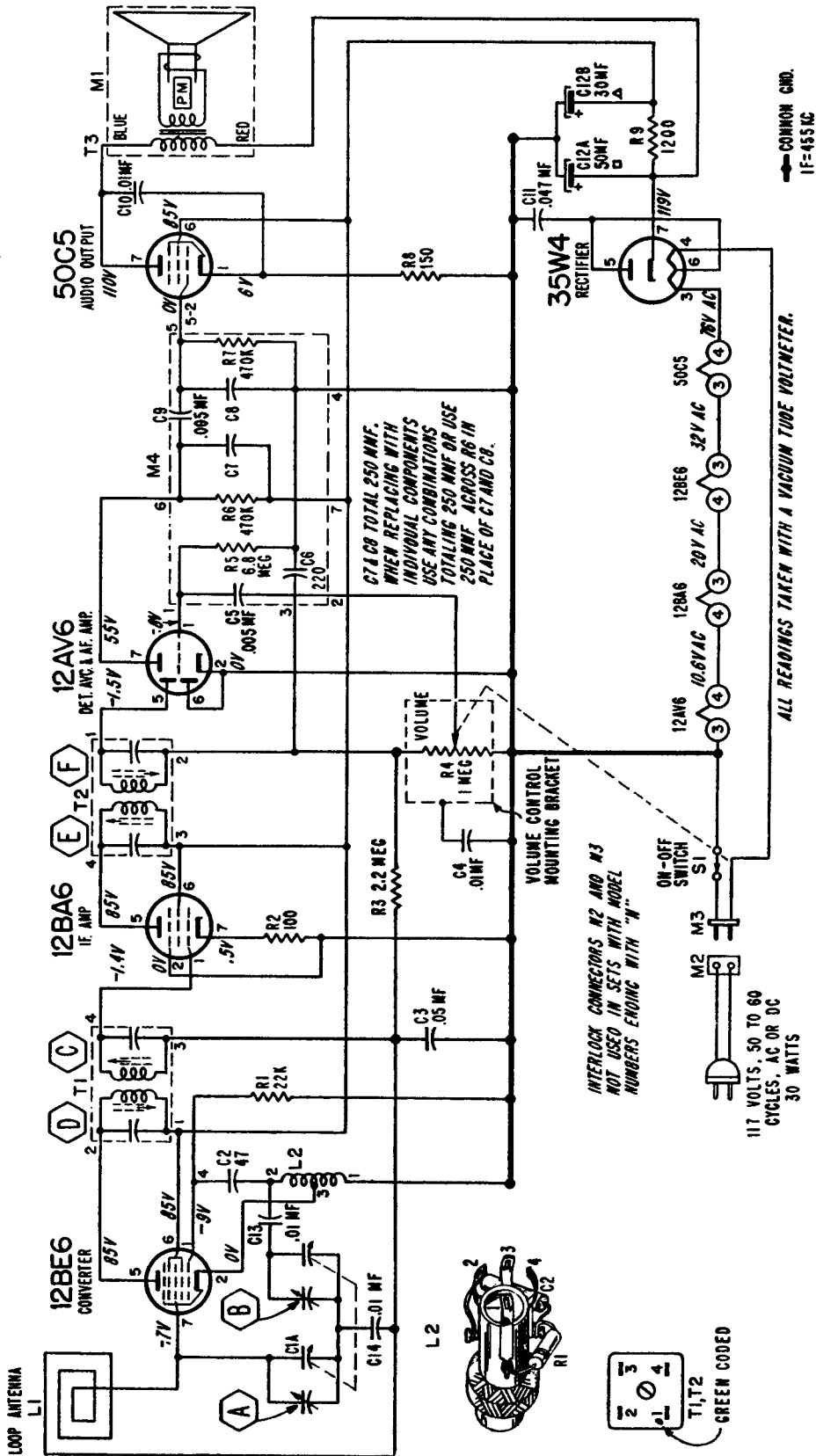

Figure 1. Bottom View of Chassis.

MANUAL OF 1955 MOST-OFTEN-NEEDED RADIO DIAGRAMS

Admiral Corp. Chassis 5R3, 5S3, and 5T3 (Continued)



VOLTAGE DATA

- Volts shown on schematic diagram.
- All readings made between tube socket terminals and common ground; see figure 1.
 - Dial turned to low frequency end; volume control at minimum.
 - Measured on 117 Volts AC line.
 - All voltages measured with vacuum-tube voltmeter.

VOLTAGE PRECAUTION

The chassis of this receiver is connected directly to one side of the power line. To avoid possibility of damage to test equipment or to printed circuit wiring, do not place the chassis directly on a metal service bench, tools or other metal objects.

When taking voltage readings or making resistance measurements, use test leads with needle point prods to avoid possibility of short circuit between sections of the printed circuit wiring.

MANUAL OF 1955 MOST-OFTEN-NEEDED RADIO DIAGRAMS

Admiral

Chassis 5R3, 5S3, and 5T3 (Continued)

Service Data and Alignment Information

Frequency Range: Standard broadcast band, 535 to 1620 KC.

Intermediate Frequency: 455 KC.

Power Supply: Power line of 117 volts, 50 to 60 cycles AC or DC.

Power Consumption: 30 watts.

Antenna: Built-in loop antenna.

Speaker: 6" PM. with Alnico V magnet. Voice coil impedance, 3.2 ohms.

ALIGNMENT PROCEDURE

- Use an isolation transformer if available; otherwise, connect a .1 mfd. capacitor in series with low side of signal generator and connect to chassis.
Caution: Do not connect a ground wire directly to chassis.
- Set volume control full on.
- Connect output meter across speaker voice coil.

- Use lowest setting of signal generator capable of producing adequate indication on lowest scale of output meter.
- Use a non-metallic alignment tool with a blade 3/32" wide for aligning IF transformers.
- Repeat adjustments to insure good results.

STEP	CONNECTION OF SIGNAL GENERATOR	SIGNAL GENERATOR FREQUENCY	RECEIVER GANG SETTING	ADJUSTMENT
1	Through a .1 mfd capacitor to pin 7 of the 12BE6 (Converter) tube	455 KC	Gang fully open	"E", "F", "C" and "D" for maximum output
2	Same as "STEP 1"	1620 KC	Gang fully open	"B" for maximum output
3	Radiated Signal. Loop of several turns of wire, or place generator lead close to receiver loop for adequate signal pickup.	1400 KC	Tune in generator signal	"A" for maximum output

*Adjustments "C" and "E" made from underside of chassis; see figure 1.

An open or damaged section of "printed" circuit wiring can be replaced by soldering a short jumper wire across the points to be connected. Pigtail trimmings from capacitors and resistors are ideal for this purpose.

To avoid need for complete tube socket replacement, defective tube socket pin clips may be replaced individually. Tube socket pin clips are available under part number 87A35-2.

Note: If sockets must be replaced, the tubular shield (center connection) at the bottom of each tube socket must be securely soldered to the "printed" circuit wiring, otherwise hum or oscillation will result.

TO REMOVE CHASSIS FROM CABINET

To remove the chassis from the cabinet, proceed as follows:

Remove the line cord plug from the AC outlet, the knobs from the front of the cabinet, and the three hex head screws and the two snap buttons in the corners of the cabinet back. Remove the screw under the **Tuning** knob,

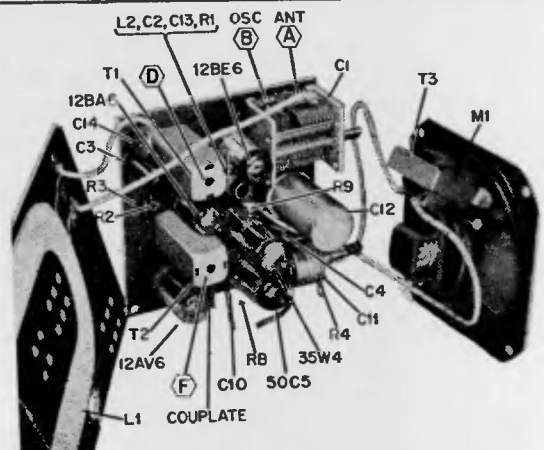

Figure 2. Top View of Chassis. Location of components and alignment points shown.

the screw that holds the **Volume** control bracket to the cabinet and the screw that holds the line cord retainer or interlock to the cabinet. Slide the chassis out of its mounting rack after disconnecting the output transformer leads.

MANUAL OF 1955 MOST-OFTEN-NEEDED RADIO DIAGRAMS

Arvin INDUSTRIES, INC., MODEL 840T - 842T

RE 278-1

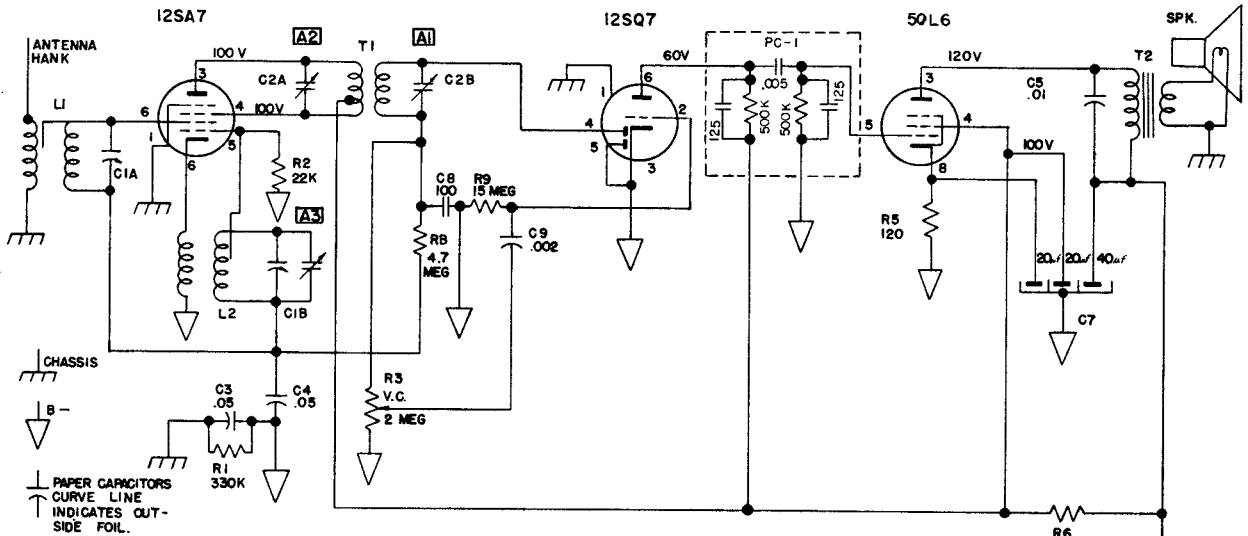

VOLTAGE READINGS SHOWN AT SOCKET PRONGS ARE TO B- AND ARE TAKEN WITH NO SIGNAL, AC LINE VOLTAGE AT 117 V. AC. MEASURED WITH VACUUM TUBE VOLTMETER.

RESISTANCE VALUES ARE IN OHMS, K=1,000, MEG.=1,000,000. CAPACITANCE VALUES LESS THAN (1) ARE IN MICROFARADS, (μ F), AND VALUES OF (1) OR GREATER ARE IN MICRO-MICROFARADS, ($\mu\mu$ F), UNLESS OTHERWISE INDICATED.

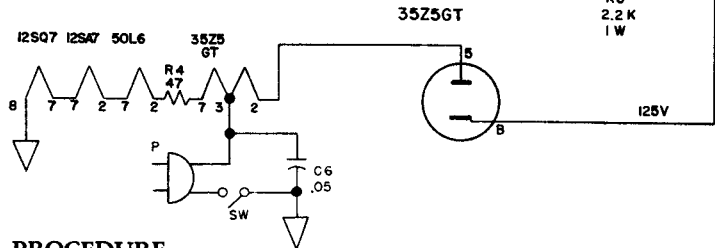

ALIGNMENT PROCEDURE

Position of Variable	Frequency of Generator	Dummy Antenna	Generator Output Connection	Trimmers Adj. in order shown for Maximum Output	Function of Trimmer
Open	455 Kc.	.05 μ f	Pin 8 12SA7	A1, A2	I. F.
1400 Kc.	1400 Kc.	50 μ f	Antenna Lug with Hank removed	** A3	Oscillator

** Since the antenna section of the variable capacitor has no trimmer, the rotor of the variable should be rocked back and forth on both sides of 1400 Kc while adjusting the oscillator trimmer for maximum output.

Check sensitivity at 600 Kc. If weak, adjust antenna section plates for maximum output at 600 Kc. Tracking of the capacitor at points other than 1400 Kc is accomplished by bending the outside plates on the variable capacitor rotor, which are cut for this purpose.

The alignment procedure should be repeated stage by stage in the original order for greatest accuracy. Always keep the output from the test oscillator at its lowest possible value to make the AVC action of the receiver ineffective.

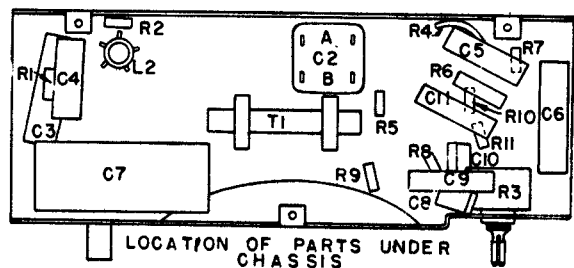
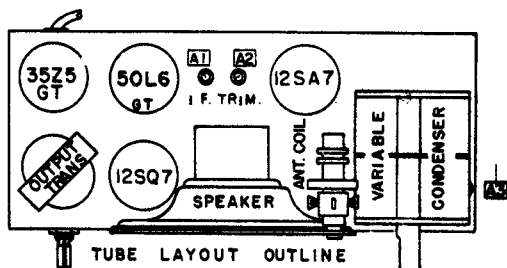

MANUAL OF 1955 MOST-OFTEN-NEEDED RADIO DIAGRAMS

Arvin INDUSTRIES, INC., MODEL 848T - 849T

RE 369

ALIGNMENT PROCEDURE

Output meter connection Speaker voice coil
 Output meter reading to indicate .5 watt output 1.26 Volts
 Connection of generator ground lead Floating ground
 Position of volume control Fully clockwise

Position of Variable	Frequency of Generator	Dummy Antenna	Generator Output Connection	Trimmer Adjustment for Maximum Output	Function of Trimmer
Open 1400 Kc	455 Kc 1400 Kc	.05 μ f 50 μ f	Pin 7 12BE6 Antenna Clip (Blue wire disconnected)	A1, A2 A3 Rock Variable while making this adj. to track antenna plates	I. F. Oscillator
600 Kc	600 Kc	50 μ f	Antenna Clip (Blue wire disconnected)	Antenna Sections plates	Check point

Keep signal generator at a low value to prevent detuning by AVC action.

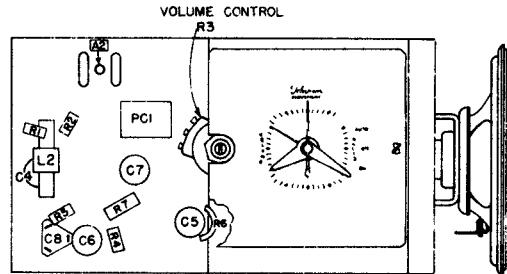
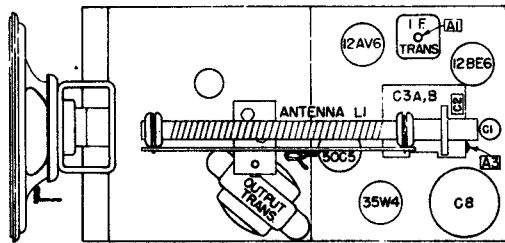

LOCATION OF PARTS UNDER CHASSIS

APROX. INPUT FOR 500 MILLIWATTS O.T.P.D.T (126 VOLTS ACROSS VOICE COIL)
 30% MODULATION @ 400 CPS

ANTENNA TRANSFORMER CLIP THROUGH 50 μ f CONDENSER 930-1000 KC.
 STANDARD LOOP 11,000 μ f - 1000 KC
 MIXER GRID THROUGH 0.05 μ f CONDENSER 8,000 μ f - 455 KC

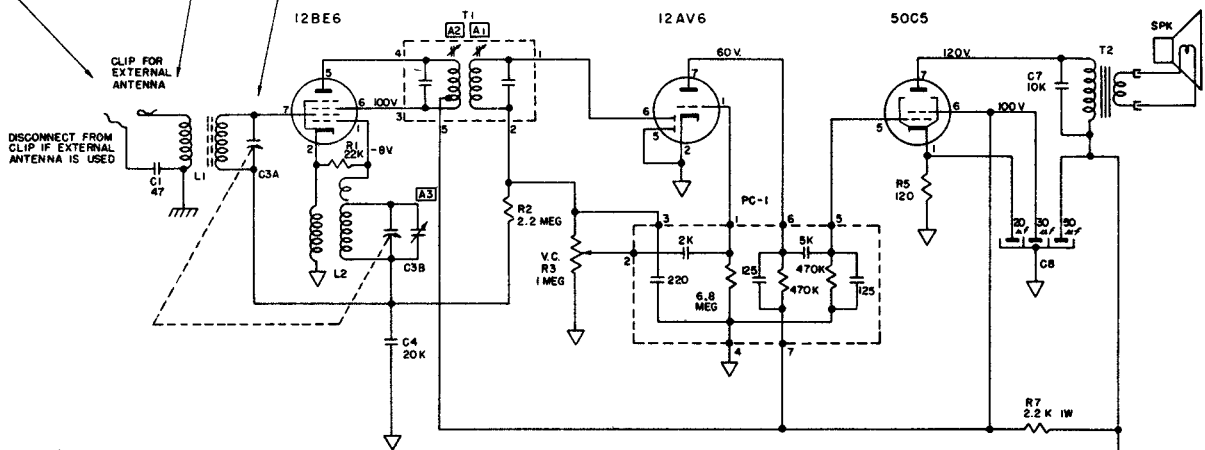

∇ B-
 CHASSIS

VOLTAGE READINGS SHOWN AT SOCKET PRONGS ARE TO B- AND ARE TAKEN WITH NO SIGNAL, AC LINE VOLTAGE AT 117 V AC MEASURED WITH VACUUM TUBE VOLTMETER

RESISTANCE VALUES ARE IN OHMS: K=1,000, MEG=1,000,000. CAPACITANCE VALUES LESS THAN (1) ARE IN MICROFARADS, (μ f), AND VALUES OF (1) OR GREATER ARE IN MICROFARADS, (μ mF). UNLESS OTHERWISE INDICATED.

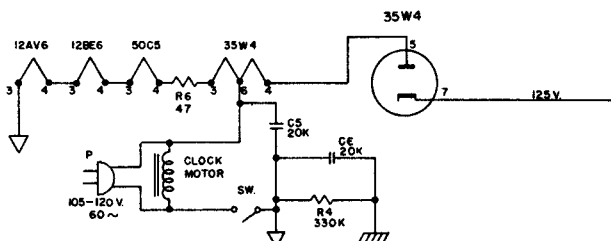

MANUAL OF 1955 MOST-OFTEN-NEEDED RADIO DIAGRAMS

ARVIN Industries

MODEL 850T -853T

RE 375

ALIGNMENT PROCEDURE

Output meter connection..... Across speaker voice coil
 Output meter reading to indicate 500 milliwatts (standard output).. 1.26 volts
 Connection of generator ground lead..... Floating ground
 Generator modulation..... 30% 400 cycles
 Position of volume control..... Fully clockwise

Position of Variable	Frequency of Generator	Dummy Antenna	Generator Output Connection	Trimmers Adjusted in Order Shown for Maximum Output	Function of Trimmer
Open	455	.05 μ f	Pin 7 12BE6	A1, A2, A3, A4	I. F. Oscillator Antenna
Open	1650		* Test Loop	A5	
1400	1400		* Test Loop	A6	
600	600		* Test Loop	Check Point	

* Standard Hazeltine Test Loop Model 1150 or 3 turns of wire about 6" in diameter placed about one foot from the set loop.

The alignment procedure should be repeated in the original order for greatest accuracy. Always keep the output from the signal generator at its lowest possible value to make the AVC action of the receiver ineffective.

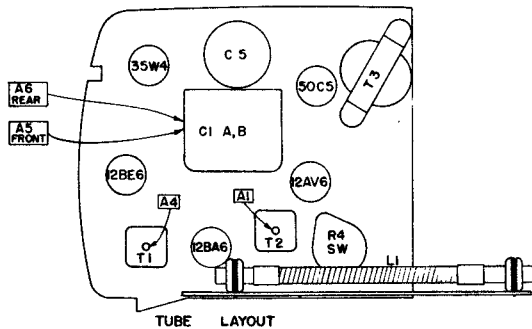

TUBE LAYOUT

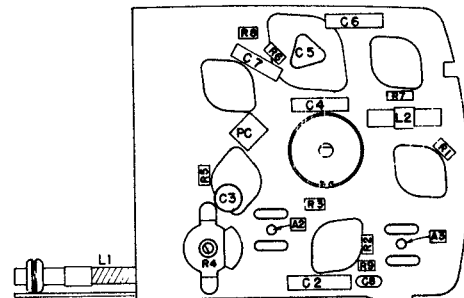

LOCATION OF PARTS UNDER CHASSIS

APPROXIMATE INPUT FOR 500 MILLIWATTS OUTPUT (1.26 VOLTS ACROSS VOICE COIL) 30% MODULATION @ 400 C.P.S.

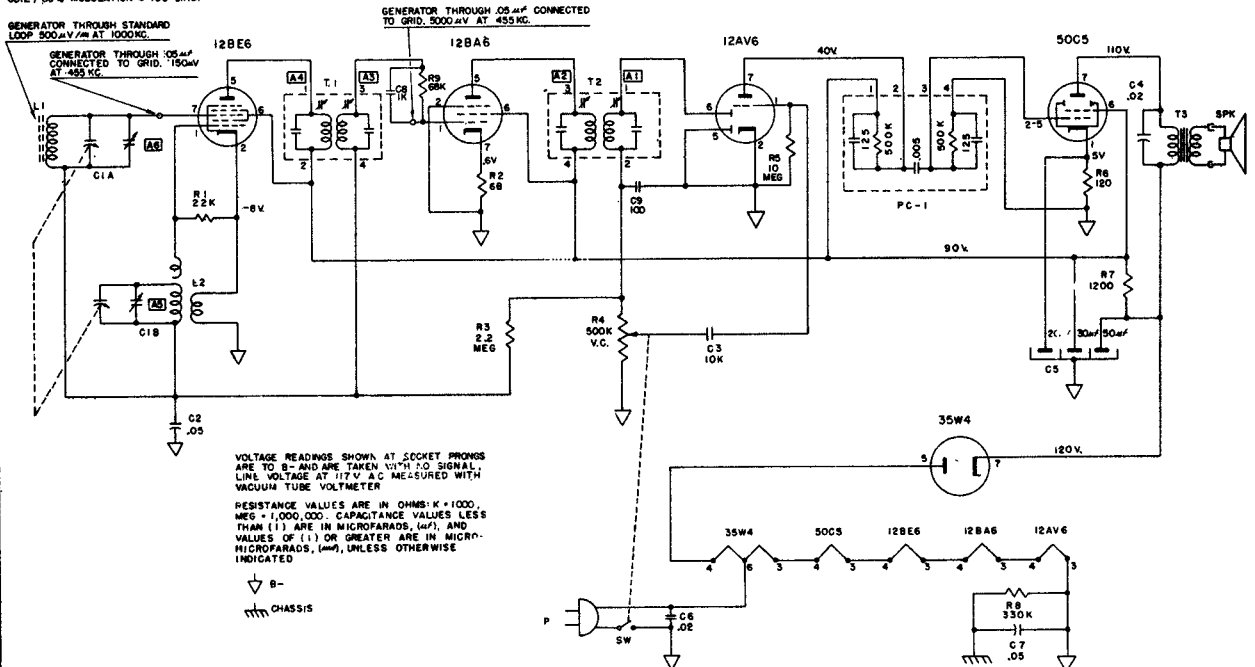

MANUAL OF 1955 MOST-OFTEN-NEEDED RADIO DIAGRAMS

ARVIN Industries

MODEL 851T - 855T

RE 377

ALIGNMENT PROCEDURE

Output meter connection Across speaker voice coil
 Output meter reading to indicate 500 milliwatts (standard output) . . . 1.26 volts
 Connection of generator ground lead Floating ground
 Generator modulation 30% 400 cycles
 Position of volume control Fully clockwise

Position of Variable	Frequency of Generator	Dummy Antenna	Generator Output Connection	Trimmers Adjusted in Order Shown for Maximum Output	Functions of Trimmer
Open	455	.05 μ f	Pin 7 12BE6	A1, A2, A3, A4	I. F. Oscillator Antenna
Open	1650		* Test Loop	A5	
1400	1400		* Test Loop	A6	
600	600		* Test Loop	Check Point	

* Standard Hazeltine Test Loop Model 1150 or 3 turns of wire about 6" in diameter placed about one foot from the set loop.

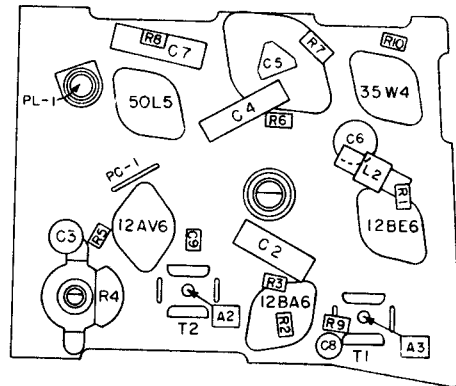
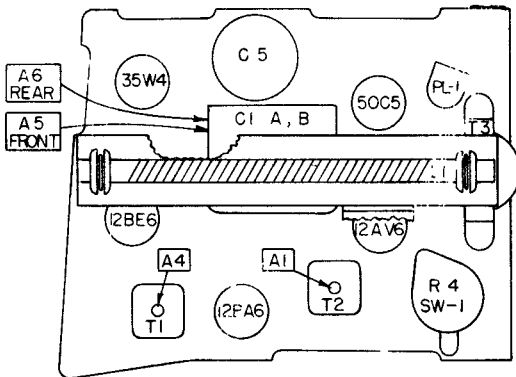

APPROXIMATE INPUT FOR 500 MILLIWATTS OUTPUT 1.26 VOLTS ACROSS VOICE COIL 30% MODULATION @ 400 CPS

LOCATION OF PARTS UNDED CHASSIS

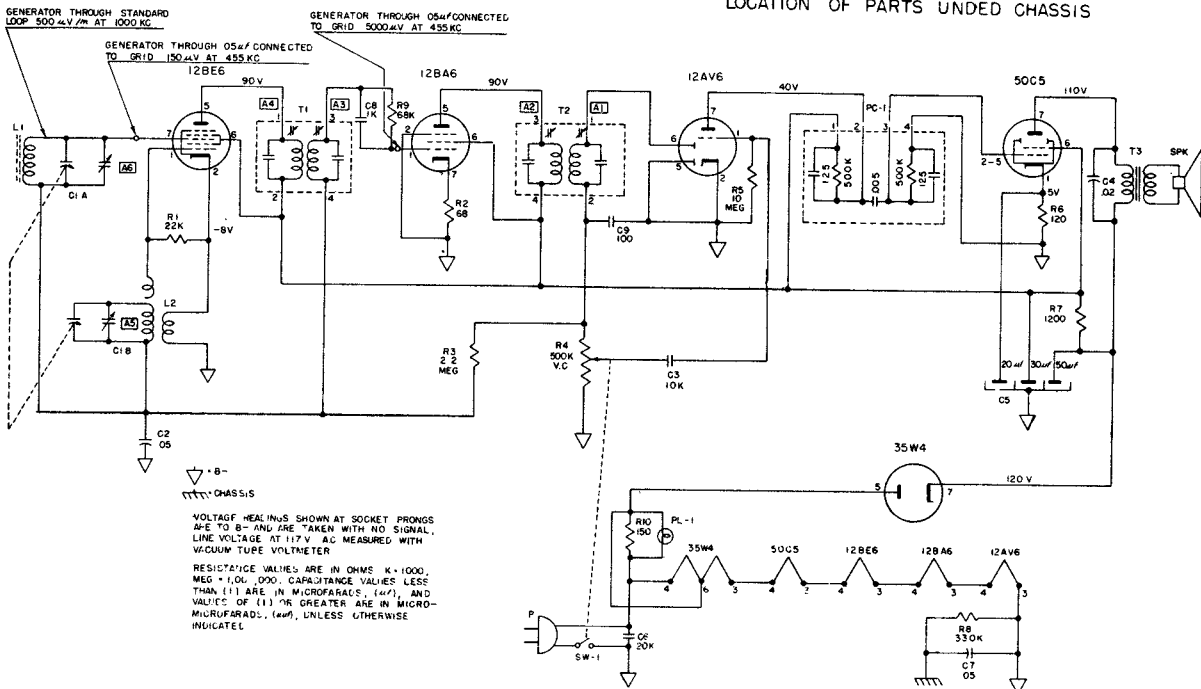

MANUAL OF 1955 MOST-OFTEN-NEEDED RADIO DIAGRAMS

ARVIN Industries

MODEL 852P - 854P

RE 381 RE 372

ALIGNMENT PROCEDURE

- Output meter reading to indicate .05 watt across voice coil 0.4V
- Generator ground lead connected floating ground
- Generator modulation 30% 400 cycles
- Position of Volume Control fully on

Position of Variable	Generator Frequency	Dummy Antenna	Generator Connections	Adjust Trimmers (In order shown)	Function of Trimmer
Open	455 Kc	.05 μ f	Mixer Grid	A1, A2, A3, A4	I. F.
Open	1650 Kc		* Test Loop	A5	Oscillator
1400 Kc	1400 Kc		* Test Loop	A6	Antenna
600 Kc	600 Kc		* Test Loop	Check Point	

* Standard Hazeltine Test Loop Model 1150 or 3 turns of wire about 6" in diameter placed about one foot from the set loop.

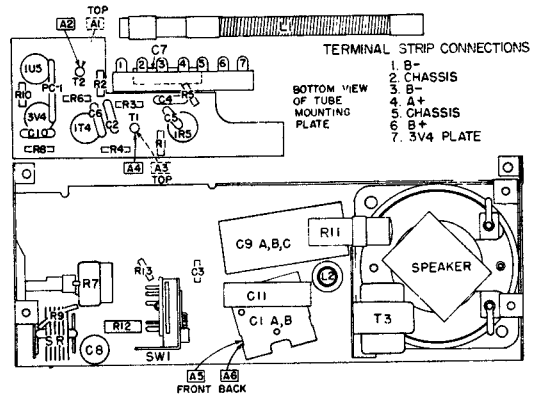
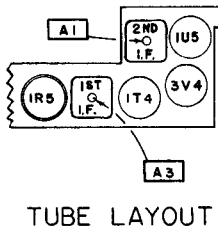

APPROX INPUT FOR 50 MILLIWATTS OUTPUT (0.4 VOLT VOICE COIL) 30% MODULATION @ 400 CPS

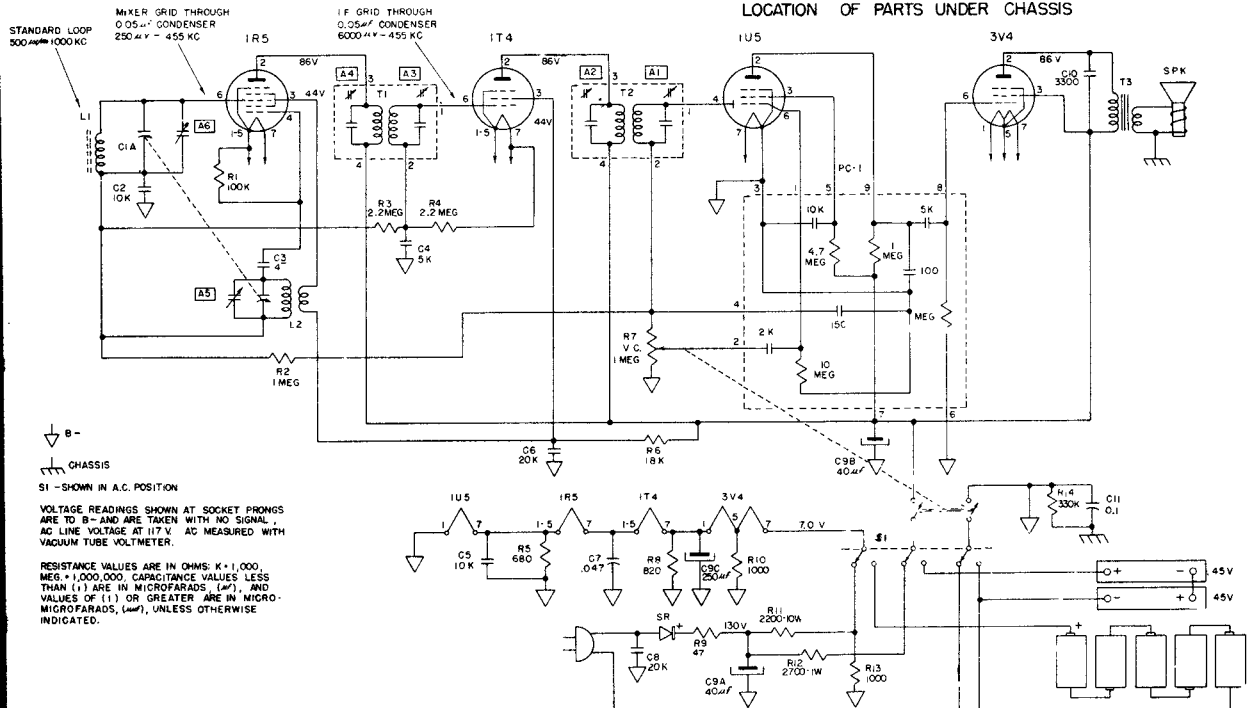

MANUAL OF 1955 MOST-OFTEN-NEEDED RADIO DIAGRAMS

ARVIN Industries

MODEL 858T - 859T

RE374

Model 857T, Chassis RE 378, is electrically similar to sets described on this page. If differs in physical respects and has a phono jack.

ALIGNMENT PROCEDURE

Output meter connection	Across speaker voice coil
Output meter reading to indicate 500 milliwatts (standard output)	1.26 volts
Connection of generator ground lead	Floating ground
Generator modulation	30% 400 cycles
Position of volume control	Fully clockwise

Position of Variable	Frequency of Generator	Dummy Antenna	Generator Output Connection	Trimmers Adjusted in order Shown for Maximum Output	Function of Trimmer
Open	455	.05 μ f	Pin 7 12BE6	A1, A2, A3, A4	I. F. Oscillator Antenna
Open	1650		* Test Loop	A5	
1400	1400		* Test Loop	A6 on	
600	600		* Test Loop	Check Point	

* Standard Hazeltine Test Loop Model 1150 or 3 turns of wire about 6" in diameter placed about one foot from the set loop.

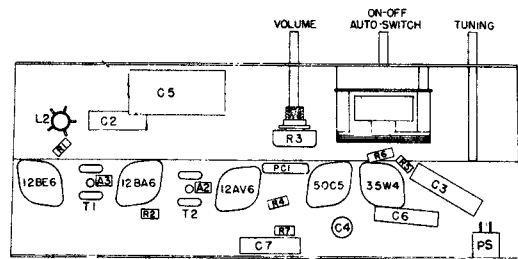
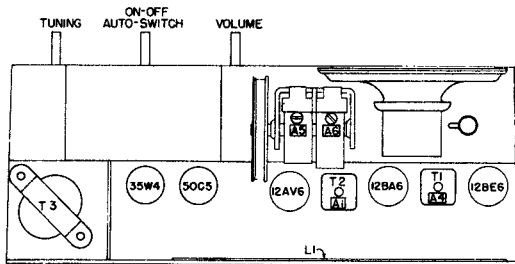

LOCATION OF PARTS UNDER CHASSIS

APPROXIMATE INPUT FOR 500 MILLIWATTS OUTPUT (1.26 VOLTS ACROSS VOICE COIL) 30% MODULATION @ 400 CPS

GENERATOR THROUGH STANDARD LOOP 500 μ V/7M AT 1000 KC
 GENERATOR THROUGH .05 μ f CONNECTED TO GRID 150 μ V AT 455 KC
 GENERATOR THROUGH .05 μ f CONNECTED TO GRID 3000 μ V AT 455 KC

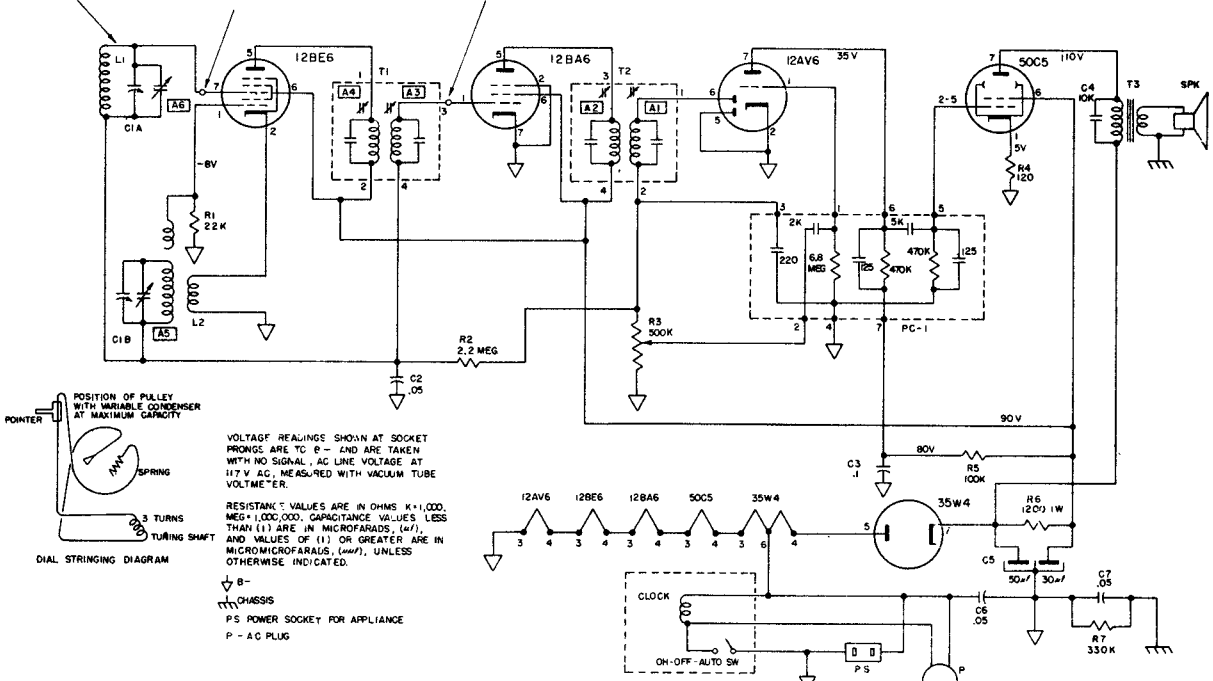

MANUAL OF 1955 MOST-OFTEN-NEEDED RADIO DIAGRAMS

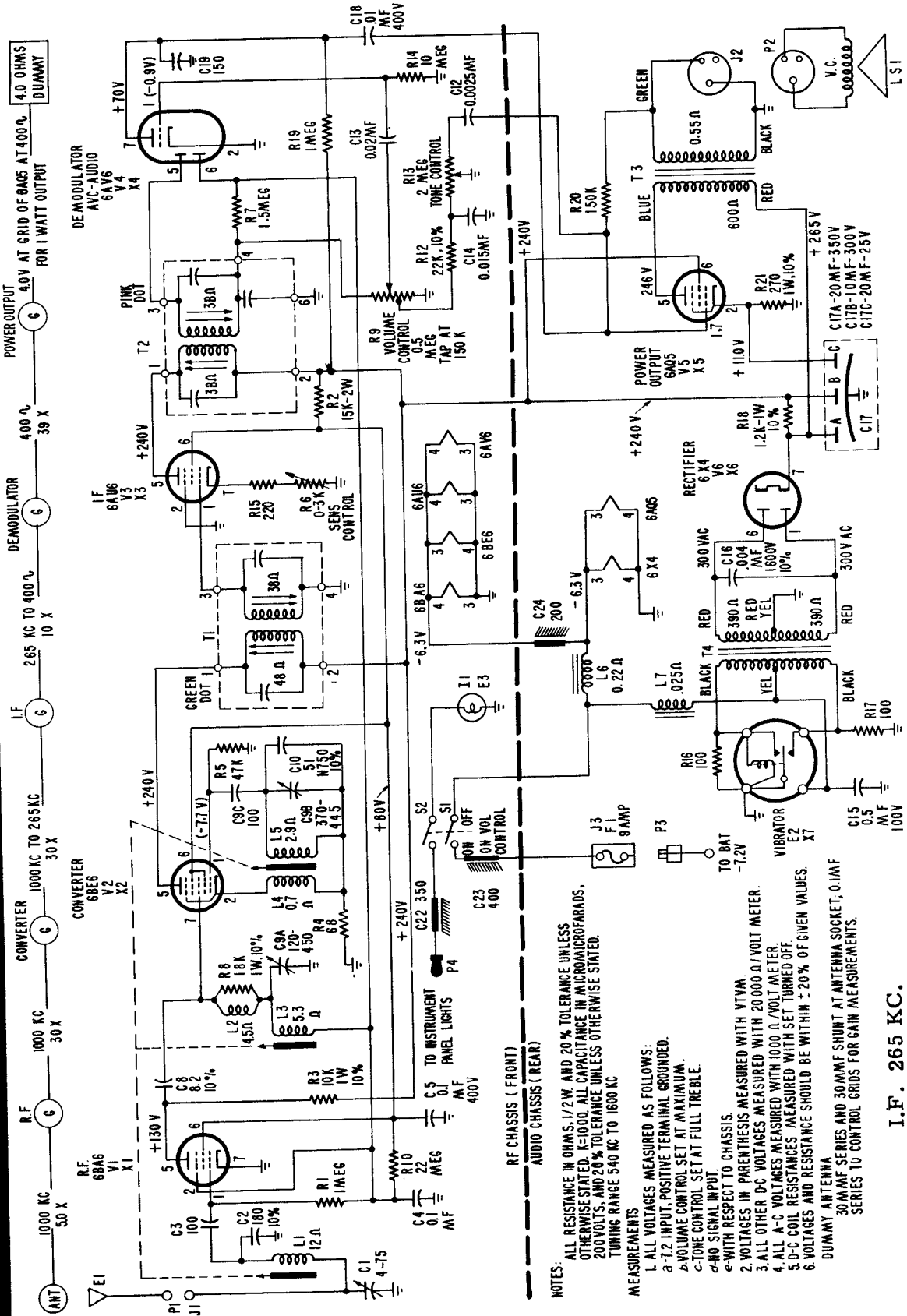

I.F. 265 KC.

BENDIX RADIO Serial No. 5BF, Model R5BF, FORD Model No. FDH-18805-B1

MANUAL OF 1955 MOST-OFTEN-NEEDED RADIO DIAGRAMS

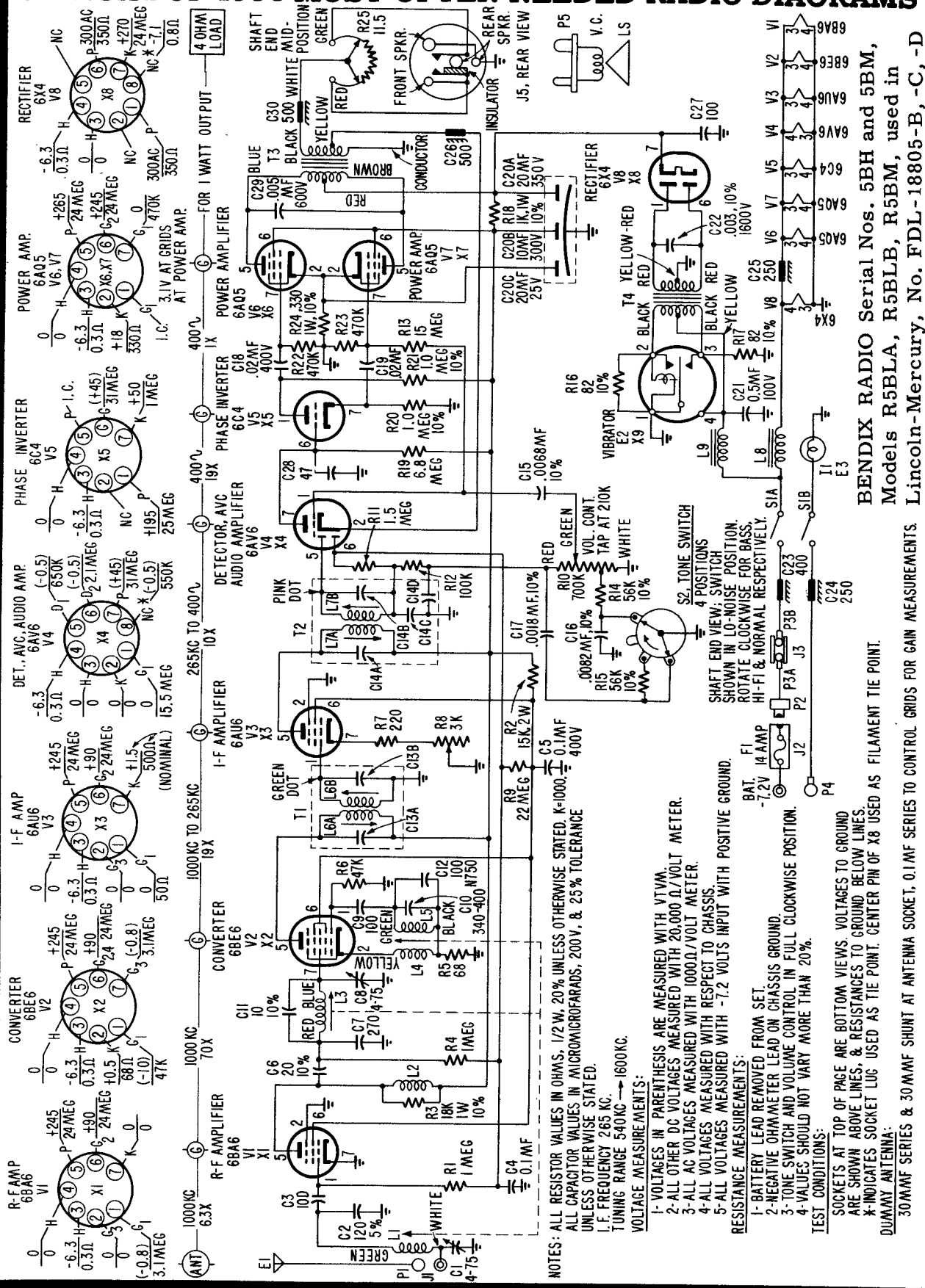

BENDIX RADIO Serial Nos. 5BH and 5BM, Models R5BLA, R5BLB, R5BM, used in Lincoln-Mercury, No. FDL-18805-B, -C, -D

30MMF SERIES & 30MMF SHUNT AT ANTENNA SOCKET, 0.1MF SERIES TO CONTROL GRIDS FOR GAIN MEASUREMENTS

TEST CONDITIONS:

- 1- BATTERY LEAD REMOVED FROM SET.
- 2- NEGATIVE OHMMETER LEAD ON CHASSIS GROUND.
- 3- TONE SWITCH AND VOLUME CONTROL IN FULL CLOCKWISE POSITION.
- 4- VALUES SHOULD NOT VARY MORE THAN 20%.

RESISTANCE MEASUREMENTS:

- 1- VOLTAGES IN PARENTHESES ARE MEASURED WITH VTVM.
- 2- ALL OTHER DC VOLTAGES MEASURED WITH 20,000 Ω/VOLT METER.
- 3- ALL AC VOLTAGES MEASURED WITH 1000 Ω/VOLT METER.
- 4- ALL VOLTAGES MEASURED WITH RESPECT TO CHASSIS.
- 5- ALL VOLTAGES MEASURED WITH -7.2 VOLTS INPUT WITH POSITIVE GROUND.

VOLTAGE MEASUREMENTS:

- 1- VOLTAGES IN PARENTHESES ARE MEASURED WITH VTVM.
- 2- ALL OTHER DC VOLTAGES MEASURED WITH 20,000 Ω/VOLT METER.
- 3- ALL AC VOLTAGES MEASURED WITH 1000 Ω/VOLT METER.
- 4- ALL VOLTAGES MEASURED WITH RESPECT TO CHASSIS.
- 5- ALL VOLTAGES MEASURED WITH -7.2 VOLTS INPUT WITH POSITIVE GROUND.

NOTES: ALL RESISTOR VALUES IN OHMS, 1/2 W, 20% UNLESS OTHERWISE STATED. K=1000, 0.1MF UNLESS OTHERWISE STATED. ALL CAPACITOR VALUES IN MICROMICROFARADS, 200V, & 25% TOLERANCE UNLESS OTHERWISE STATED. I.F. FREQUENCY 265 KC. TUNING RANGE 540KC → 1600KC.

TEST CONDITIONS:

- 1- BATTERY LEAD REMOVED FROM SET.
- 2- NEGATIVE OHMMETER LEAD ON CHASSIS GROUND.
- 3- TONE SWITCH AND VOLUME CONTROL IN FULL CLOCKWISE POSITION.
- 4- VALUES SHOULD NOT VARY MORE THAN 20%.

RESISTANCE MEASUREMENTS:

- 1- VOLTAGES IN PARENTHESES ARE MEASURED WITH VTVM.
- 2- ALL OTHER DC VOLTAGES MEASURED WITH 20,000 Ω/VOLT METER.
- 3- ALL AC VOLTAGES MEASURED WITH 1000 Ω/VOLT METER.
- 4- ALL VOLTAGES MEASURED WITH RESPECT TO CHASSIS.
- 5- ALL VOLTAGES MEASURED WITH -7.2 VOLTS INPUT WITH POSITIVE GROUND.

VOLTAGE MEASUREMENTS:

- 1- VOLTAGES IN PARENTHESES ARE MEASURED WITH VTVM.
- 2- ALL OTHER DC VOLTAGES MEASURED WITH 20,000 Ω/VOLT METER.
- 3- ALL AC VOLTAGES MEASURED WITH 1000 Ω/VOLT METER.
- 4- ALL VOLTAGES MEASURED WITH RESPECT TO CHASSIS.
- 5- ALL VOLTAGES MEASURED WITH -7.2 VOLTS INPUT WITH POSITIVE GROUND.

SOCKETS AT TOP OF PAGE ARE BOTTOM VIEWS. VOLTAGES TO GROUND ARE SHOWN ABOVE LINES, & RESISTANCES TO GROUND BELOW LINES. * INDICATES SOCKET LUG USED AS TIE POINT. CENTER PIN OF X8 USED AS FILAMENT TIE POINT. DUMMY ANTENNA:

30MMF SERIES & 30MMF SHUNT AT ANTENNA SOCKET, 0.1MF SERIES TO CONTROL GRIDS FOR GAIN MEASUREMENTS

MANUAL OF 1955 MOST-OFTEN-NEEDED RADIO DIAGRAMS

Capehart

CAPEHART-FARNSWORTH COMPANY

MODEL
C-14

RADIO CHASSIS
CR-93

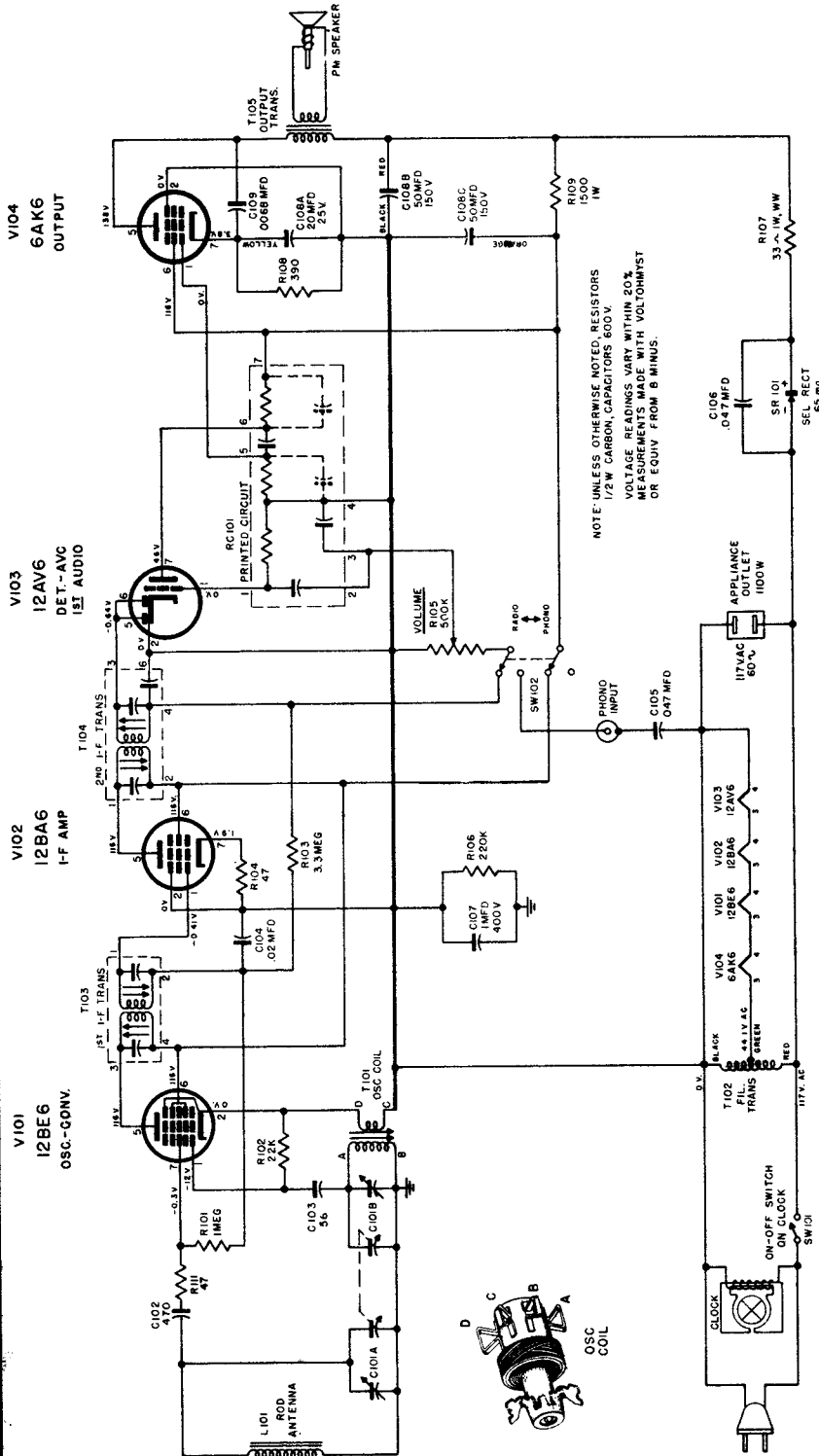

ALIGNMENT

Equipment Required:

1. Calibrated R.F. Signal Generator (Signal from 455KC to 1620KC).

2. Low Range Output Meter.

Alignment:

- a. Turn set on, adjust volume to maximum.
- b. See that dial pointer coincides with calibration marks at extremes of dial scale.
- c. Connect output meter across the speaker voice coil.

Step	Set Generator	Set Gang	Connect Generator	Adjust	To Obtain
1	455KC	Fully Open	Pin 1 V102	T104 (Top & Bottom)	Maximum
2	"	"	Across Rod Ant.	T103 (Top & Bottom)	"
3	1620KC	Fully Open	Across Rod Ant.	Oscillator Trimmer	"
4	537KC	Closed	"	T101	"
5	1500 KC	1500KC	Loosely Couple To Rod Ant.	Antenna Trimmer	"

MANUAL OF 1955 MOST-OFTEN-NEEDED RADIO DIAGRAMS

CAPEHART-FARNSWORTH COMPANY

Capehart

**Model
1P55**

**Chassis
CR-148**

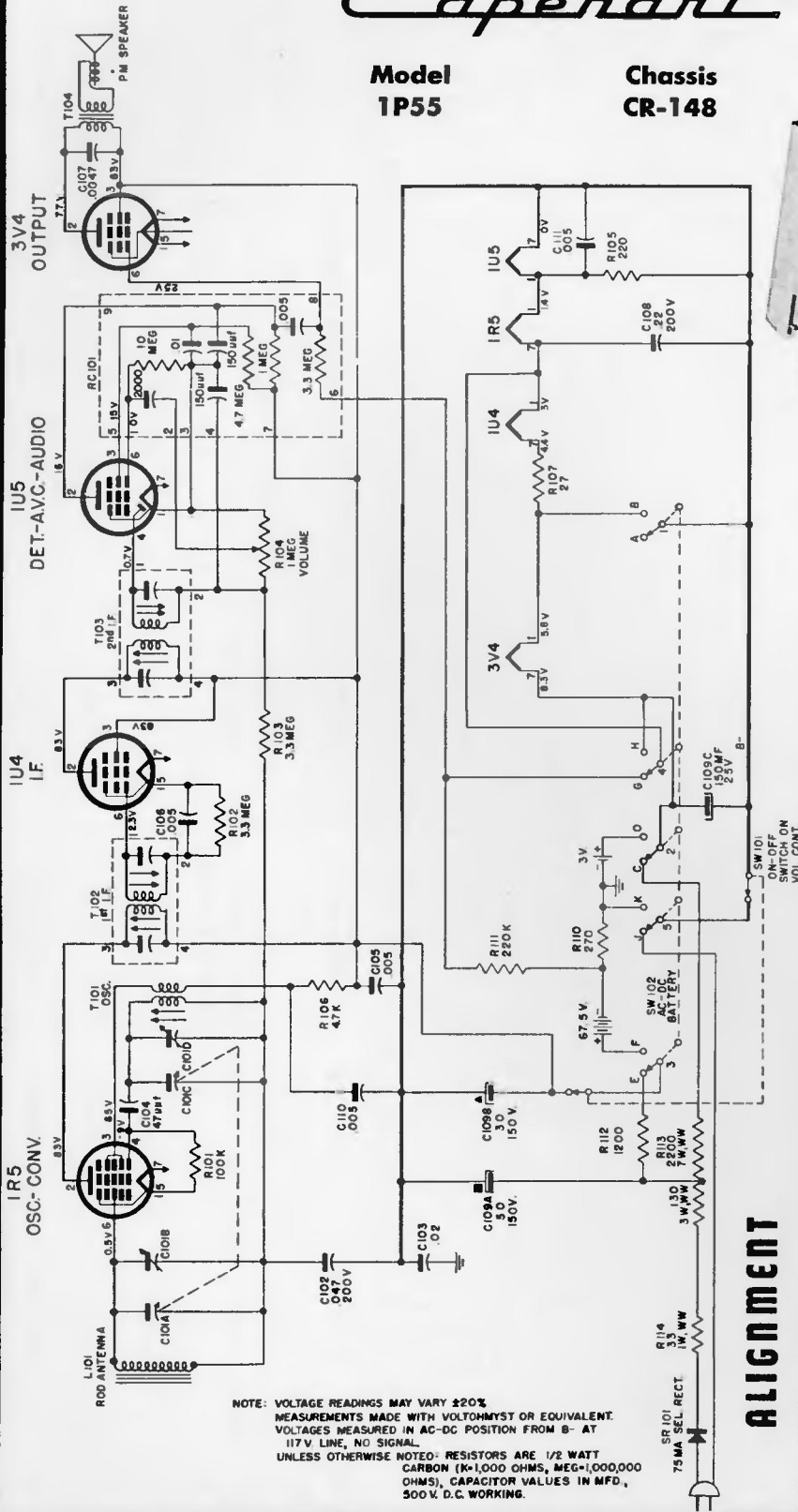
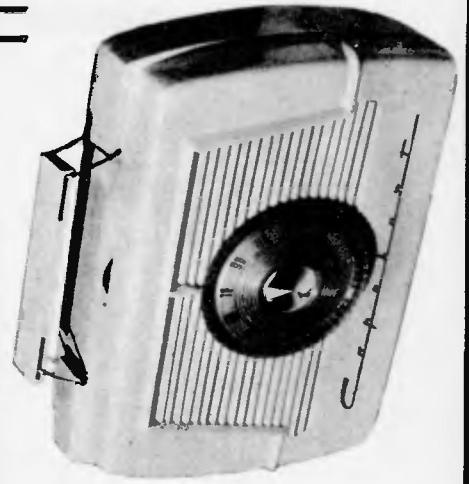

NOTE: VOLTAGE READINGS MAY VARY $\pm 20\%$
MEASUREMENTS MADE WITH VOLTOHMIST OR EQUIVALENT.
VOLTAGES MEASURED IN AC-DC POSITION FROM B- AT
117V LINE, NO SIGNAL.
UNLESS OTHERWISE NOTED: RESISTORS ARE 1/2 WATT
CARBON ($\times 1,000$ OHMS, MEG-1,000,000
OHMS), CAPACITOR VALUES IN MFD,
300V. D.C. WORKING.

ALIGNMENT

Step No.	Set R. F. Gen. at	Connect R. F. Generator to	Set Gang to	Adjust	To Obtain
1	455KC (400 cy. mod.)	Pin 6 V102 thru .1mfd cap. Ground Lead to B-	Fully Closed	T103 I. F. Trans- former (Top & Bottom)	Maximum
2	455KC (400 cy. mod.)	Pin 6 V101 thru .1mfd cap. Ground Lead to B-	Fully Closed	T102 I. F. Trans- former (Top & Bottom)	Maximum
3	540KC (400 cy. mod.)	Pin 6 V101 thru .1mfd cap. Ground Lead to B-	Fully Closed	T101 Oscillator Slug	Maximum
4	1620KC (400 kc mod.)	Pin 6 V101 thru .1mfd cap. Ground Lead to B-	Fully Open	C101D Oscillator Trimmer	Maximum
5	1500KC (400 cy. mod.)	Form a Loop and closely couple to Ant.	1500KC	C101B Antenna Trimmer	Maximum

MANUAL OF 1955 MOST-OFTEN-NEEDED RADIO DIAGRAMS

CAPEHART - FARNSWORTH

Model
3T55

Chassis
CR-150

Model
2T55

Chassis
CR-154

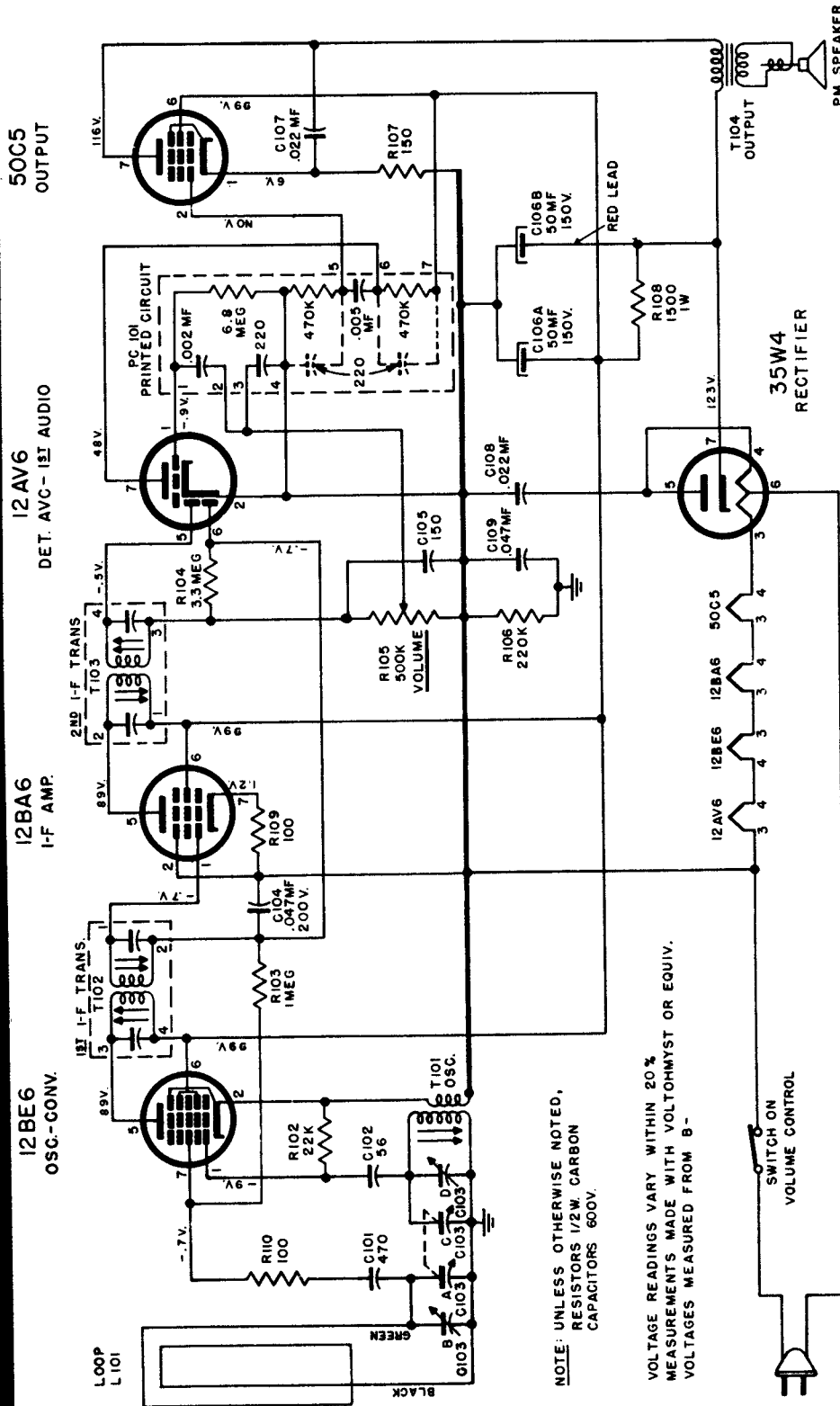

NOTE: UNLESS OTHERWISE NOTED,
RESISTORS 1/2W. CARBON
CAPACITORS 600V.

VOLTAGE READINGS VARY WITHIN 20%
MEASUREMENTS MADE WITH VOLTOHMYST OR EQUIV.
VOLTAGES MEASURED FROM B -

ALIGNMENT:

- Turn set on, adjust volume to maximum.
- See that dial pointer coincides with calibration marks at extremes of dial scale.
- Connect output meter across the speaker voice coil.
- Make a loop of the RF Generator leads (connect the leads together through a .01 mfd capacitor) and loosely couple to the Loop Antenna.

STEP	SET RF GENERATOR AT	CONDENSER GANG AT	ADJUST	TO OBTAIN
1	455KC	Fully Open at some quiet point	IF Slugs T103 T102	Maximum Output
2	1620KC	Fully Open	Osc. Trimmer C103D	Same
3	1500KC	1500KC	Ant. Trimmer C103B	Same
4	600KC	600KC	T101 Osc. Slug	Same

MANUAL OF 1955 MOST-OFTEN-NEEDED RADIO DIAGRAMS

Capehart

AMPLIFIER CHASSIS

CA-156

4PH55M
4PH55B
16PH55M
16PH55B
16PH55F

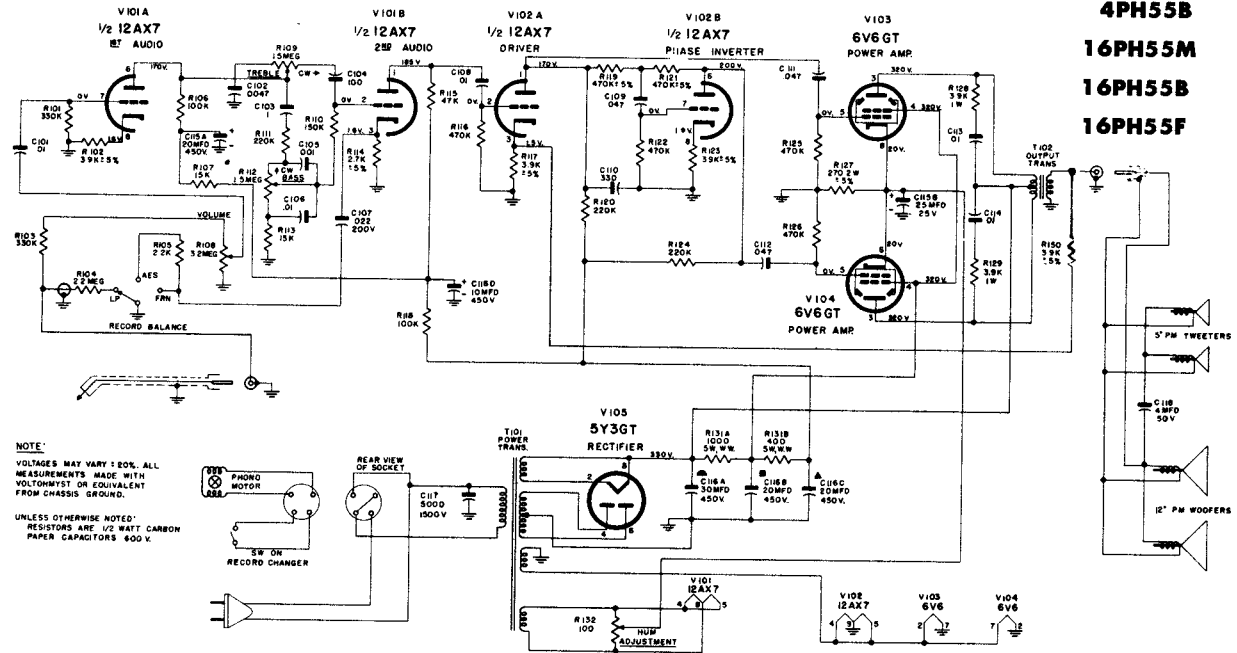

Capehart

Model Amplifier Chassis 6TP45M CA-161

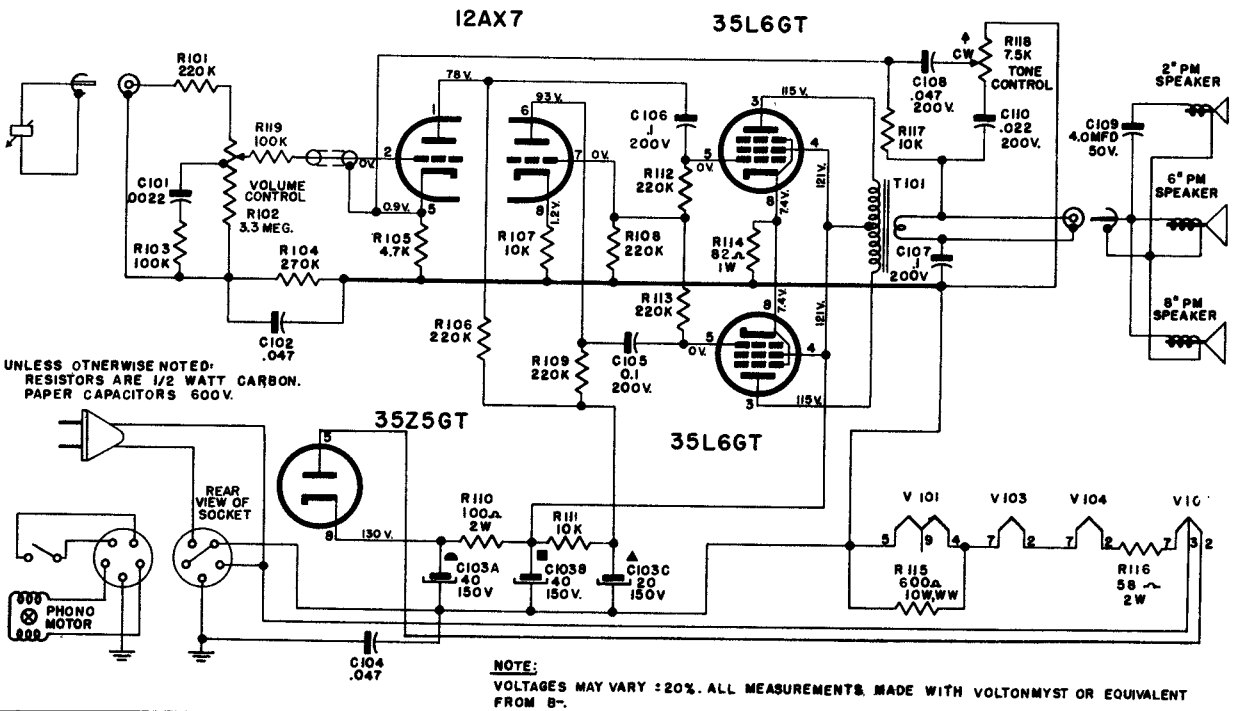

MANUAL OF 1955 MOST-OFTEN-NEEDED RADIO DIAGRAMS

CBS-Columbia, MODELS: 5155-Ebony; 5156-Ivory; 5156-Maroon; 5156-Sand

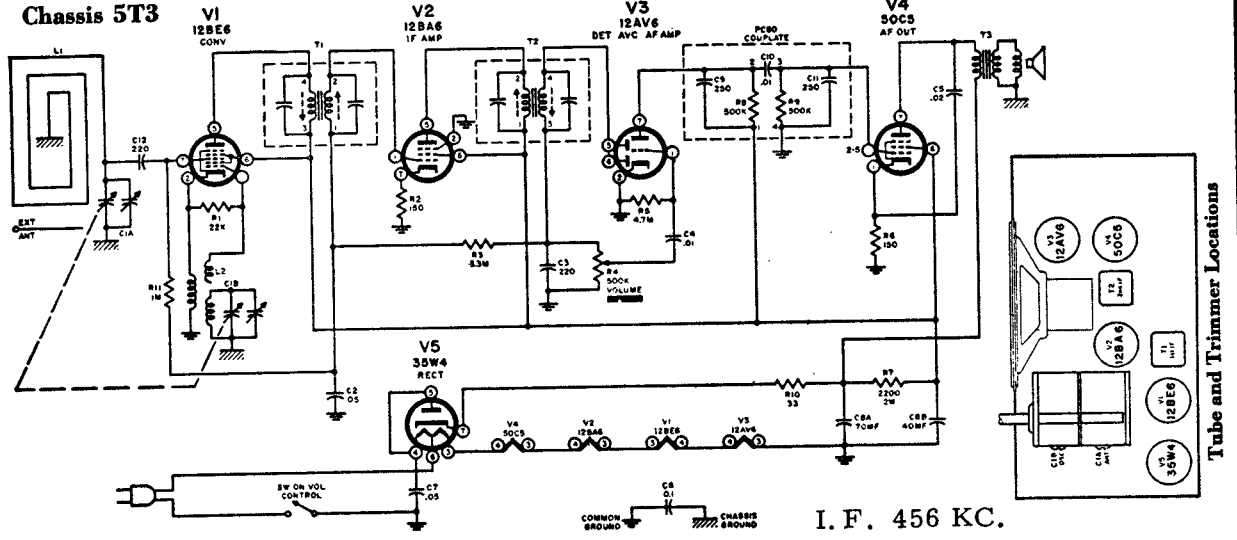

DeWALD Radio-Phonograph Models J-540 and J-541

(The circuit below is exact for J-540. Model J-541 is the same except for a jack in the voice coil circuit.)

TO PLAY PHONOGRAPH;—Turn volume control—power switch "ON". Move Radio-Phonograph switch lever to Phonograph position. Allow approximately one minute for the tubes to heat up. Select desired speed by moving speed lever over number marked on cabinet. Pull needle guard off, but do not discard. Replace needle guard when phonograph is not in use.

Set motor lever to proper speed of record.

When phonograph or radio is turned off, it is advisable to place this lever in the off position.

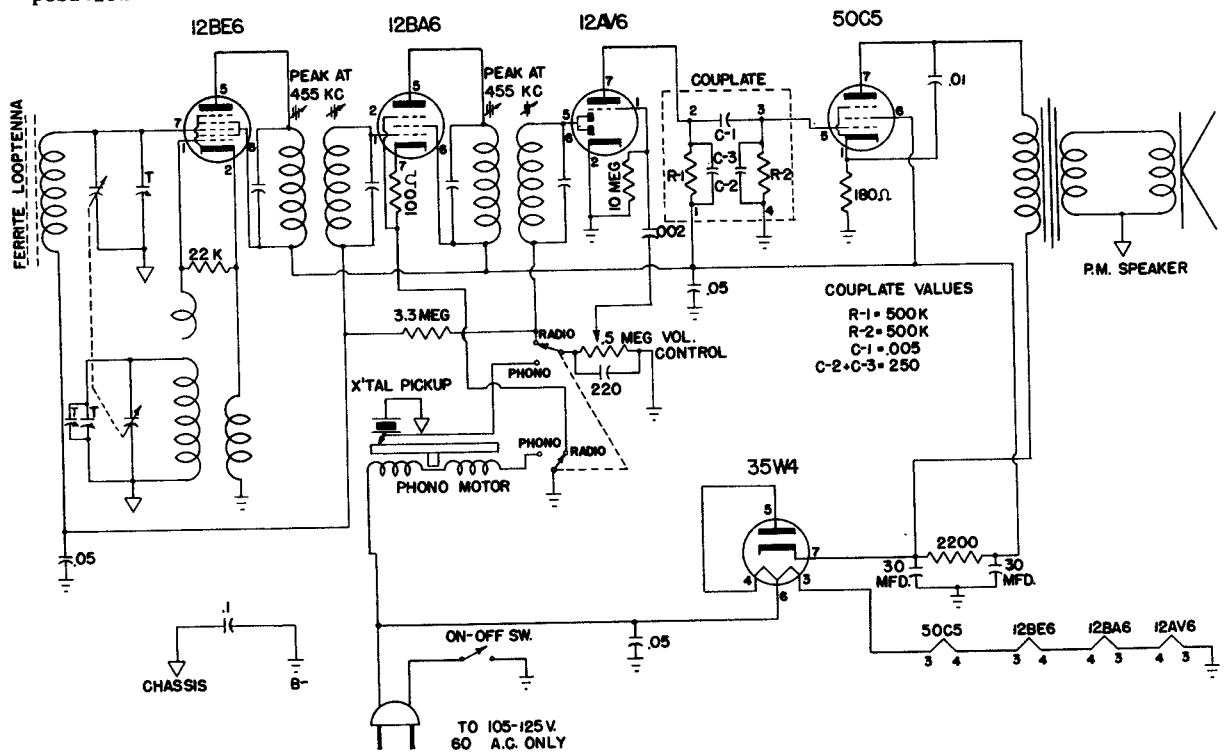

MANUAL OF 1955 MOST-OFTEN-NEEDED RADIO DIAGRAMS

Emerson

Model 811B, Chassis 120228B,
 Model 812B, Chassis 120229B,
 Model 813B, Chassis 120230B,
 Model 822B, Chassis 120232B.

The circuit printed on this page is exact for Model 812B, Chassis 120229B. Model 813B, Chassis 120230B, is electrically identical except that it uses but a single speaker. Model 811B, Chassis 120228B, also uses one speaker and T-1 grid return terminal #3 goes directly to B Neutral. Model 822B, Chassis 120232B, is like 811B with the addition of a "Jack" for attachments.

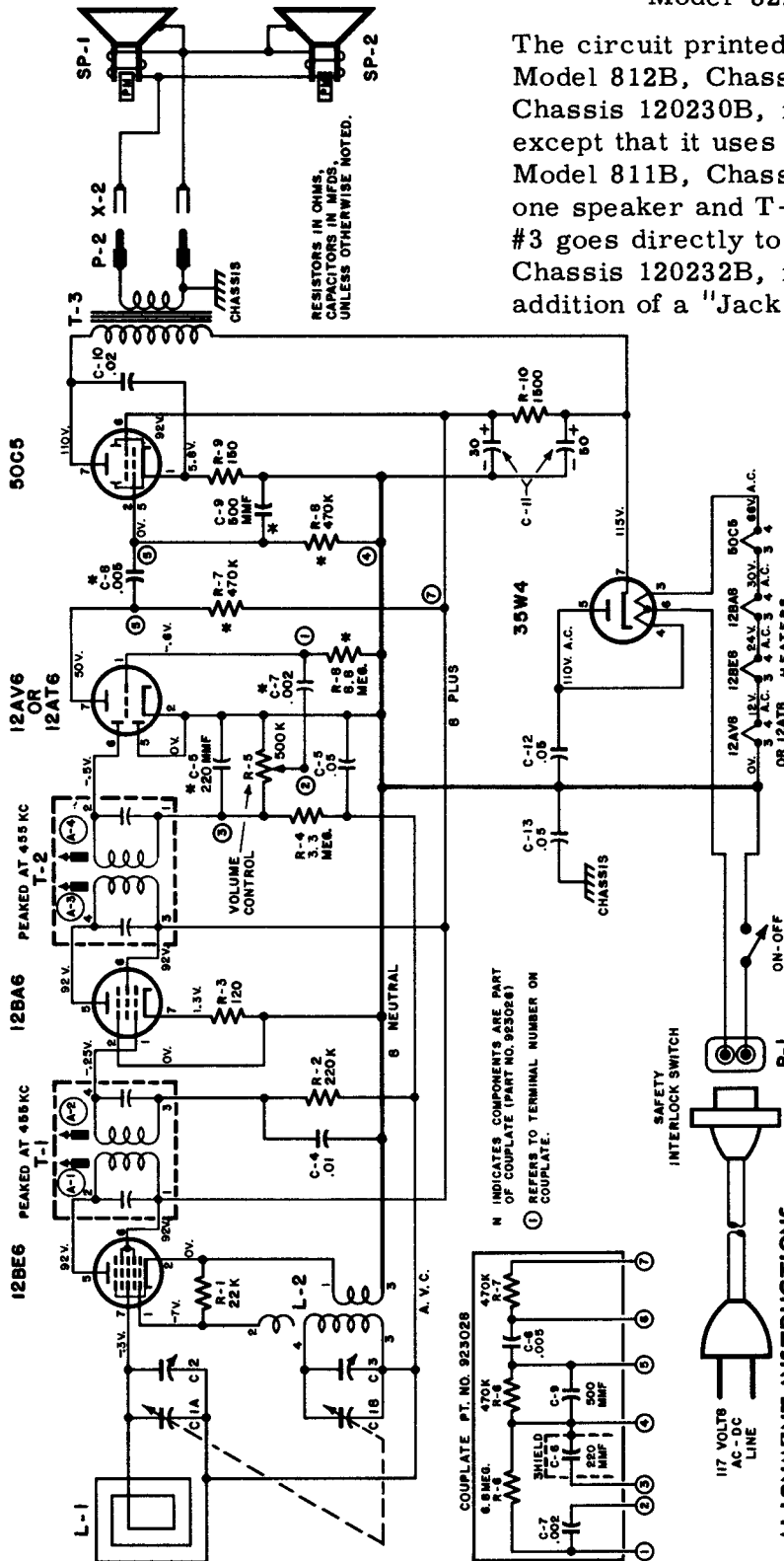

STEP	DUMMY ANTENNA	SIGNAL GENERATOR COUPLING	SIGNAL GENERATOR FREQUENCY	RADIO DIAL SETTING	OUTPUT METER	ADJUST	REMARKS
1	.005 mfd.	High side to grid (pin 7) of V1 (12BE6). Low side to B-neutral (See Alignment Note)	455 KC	Variable condenser fully open.	Across voice coil.	T2, T1 (A3, A4, A1, A2)	Adjust for maximum output.
2		Form loop of several turns and radiate signal into receiver	1620 KC	"	Across voice coil.	Trimmer C-3 (Osc.)	Adjust for maximum output.
3	"	"	1400 KC	Tune for maximum output.	Across voice coil.	Trimmer C-2 (Ant.)	Adjust for maximum output.

ALIGNMENT INSTRUCTIONS

MANUAL OF 1955 MOST-OFTEN-NEEDED RADIO DIAGRAMS

EMERSON RADIO

Information on Printed Circuit Repairs

The equipment needed for servicing printed circuit chassis are the usual standard shop tools, plus a low wattage soldering iron (approximately 25 watts) with a fine tip, low temperature rosin core solder and a small stiff bristled brush to clean away the melted solder from around the connections.

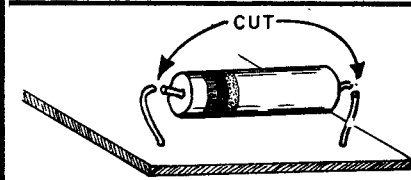

Cut resistor or capacitor leads as close to the component as possible, then connect the replacement part to the remaining section of the original leads and carefully solder.

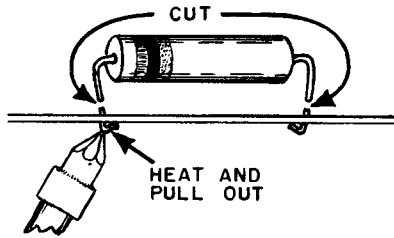

Cut resistor or capacitor leads as close to the chassis as possible. Heat connections just long enough to melt solder and remove leads from bottom one at a time. Clean area around the mounting holes and insert leads from replacement part through holes provided. Clip off excess lead, leaving a small piece to bend over and solder.

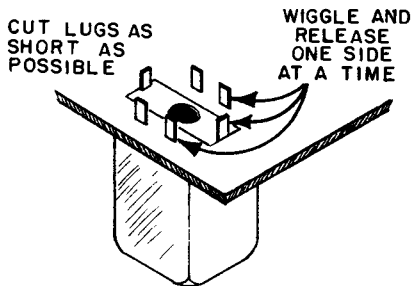

Cut transformer lugs (including spring clips) as close to chassis as possible. Heat connections (on one side) long enough for solder to melt, then wiggle loose first one side and then the other. Clean area around mounting holes and insert replacement part through same holes. Carefully resolder connections.

HEAT, REMOVE SOLDER AND STRAIGHTEN ALL LUGS.

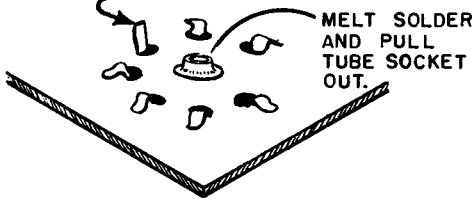

Melt and brush excess solder from socket pins and straighten out bent pins (one at a time). Remove solder from center ground lug of socket and remove socket (it may be necessary to reheat some of the lugs). Clean the area around mounting holes and insert new socket (with tube in it) in same holes. Bend socket lugs over and then carefully solder.

HEAT AND RELEASE ONE SIDE OF MOUNTING BRACKET AND THEN THE OTHER.

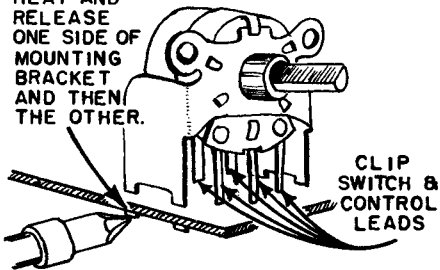

Cut the volume control and a.c. switch leads close to top of chassis. Heat these clipped leads from under the chassis and pull out with long nose pliers. Melt solder around mounting bracket lugs and straighten out these lugs if bent. Clip these lugs off as close to chassis as possible. Heat and remove one side of mounting bracket and then the other. Clean area around mounting holes and insert new part, bend lugs over slightly and carefully solder all connections.

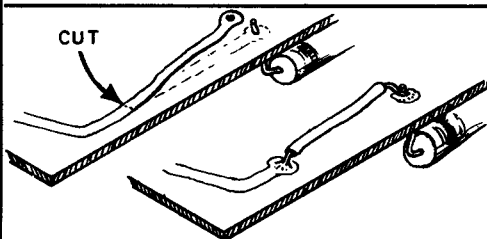

Cut off the section of the printed wiring strip that has lifted from the chassis and replace this section with a small piece of regular insulated wire. Bare wire may be used to replace short sections.

MANUAL OF 1955 MOST-OFTEN-NEEDED RADIO DIAGRAMS

Emerson

CHASSIS - 120231-B

MODEL - 814B

ALTERNATE CIRCUIT
USED ON SOME 120231-B CHASSIS.

ALIGNMENT INSTRUCTIONS

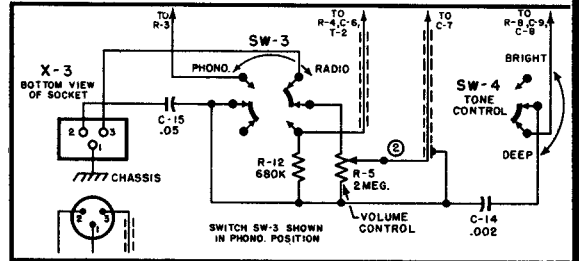

STEP	DUMMY ANTENNA	SIGNAL GENERATOR COUPLING	SIGNAL GENERATOR FREQUENCY	RADIO DIAL SETTING	OUTPUT METER	ADJUST	REMARKS
1	.005 mfd.	High side to grid (pin 7) of V1 (12BE6). Low side to B-neutral	455 KC	Variable condenser fully open.	Across voice coil.	T2, T1 (A3, A4, A1, A2)	Adjust for maximum output.
2		Form loop of several turns and radiate signal into receiver	1620 KC	"	Across voice coil.	Trimmer C-3 (Osc.)	Adjust for maximum output.
3		"	1400 KC	Tune for maximum output.	Across voice coil.	Trimmer C-2 (Ant.)	Adjust for maximum output.

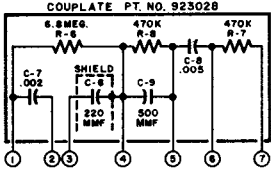
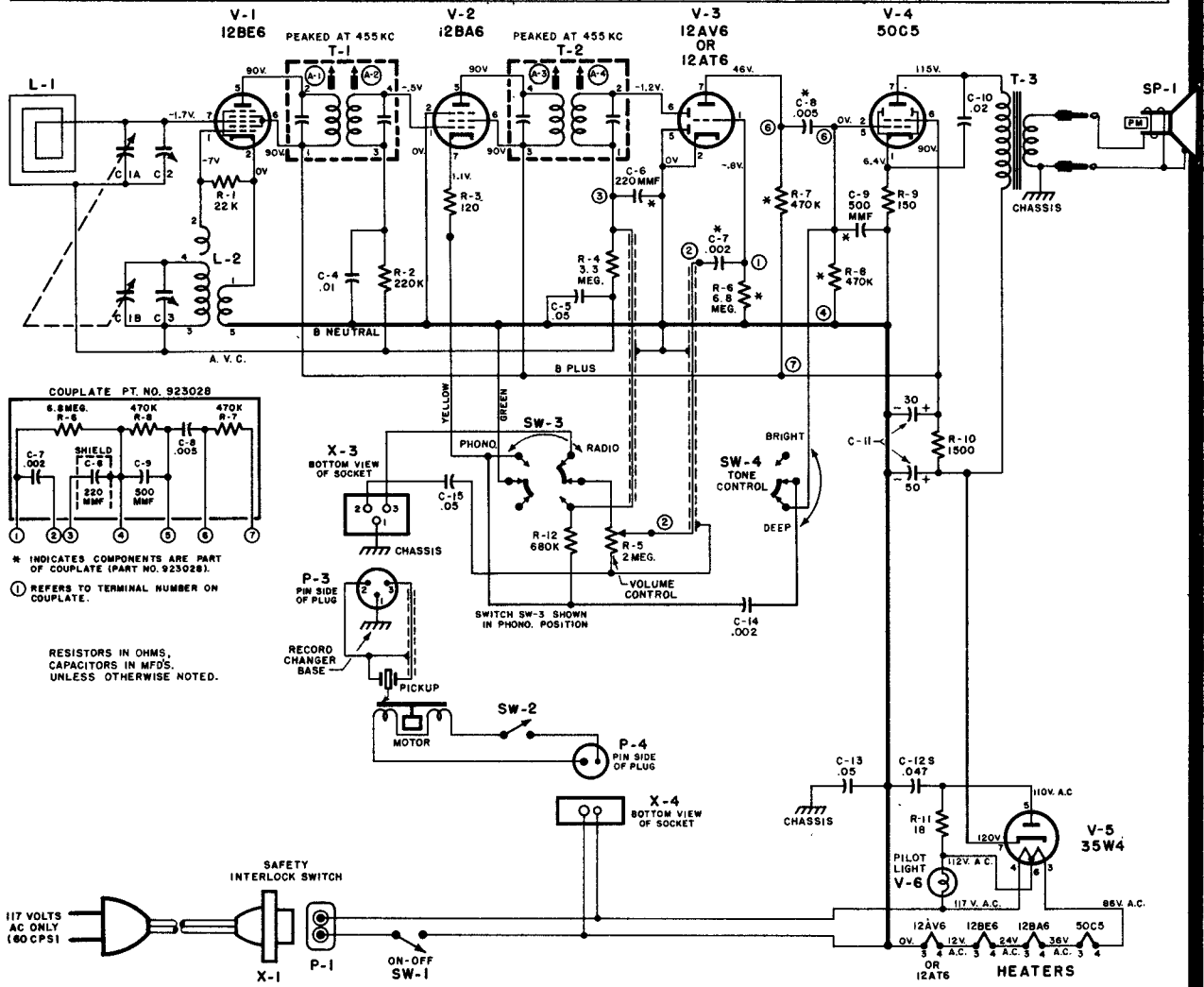

* INDICATES COMPONENTS ARE PART OF COUPLATE (PART NO. 923028).
① REFERS TO TERMINAL NUMBER ON COUPLATE.

RESISTORS IN OHMS, CAPACITORS IN MFD'S. UNLESS OTHERWISE NOTED.

Emerson Radio

MODELS - 819B, 820B

CHASSIS - 120240-B

DISASSEMBLY INSTRUCTIONS

1. Remove four screws securing changer mounting board to cabinet. Lift mounting board with changer and disconnect plug P-3 from the control chassis.
2. Remove five screws securing inside perforated panel to cabinet and lift out panel. Disconnect plug P-2 from amplifier chassis and remove the changer.
3. Remove perforated back cover and remove screw securing chassis and shield assembly to rear of cabinet.
4. Remove two nuts and washers from threaded studs securing chassis and shield assembly to bottom of cabinet. Lift this assembly to clear studs, tilt forward and slide out.
5. Remove five screws securing chassis to shield assembly and remove shield so as to have access to underside of chassis.
6. To reassemble reverse procedure 1 through 5.

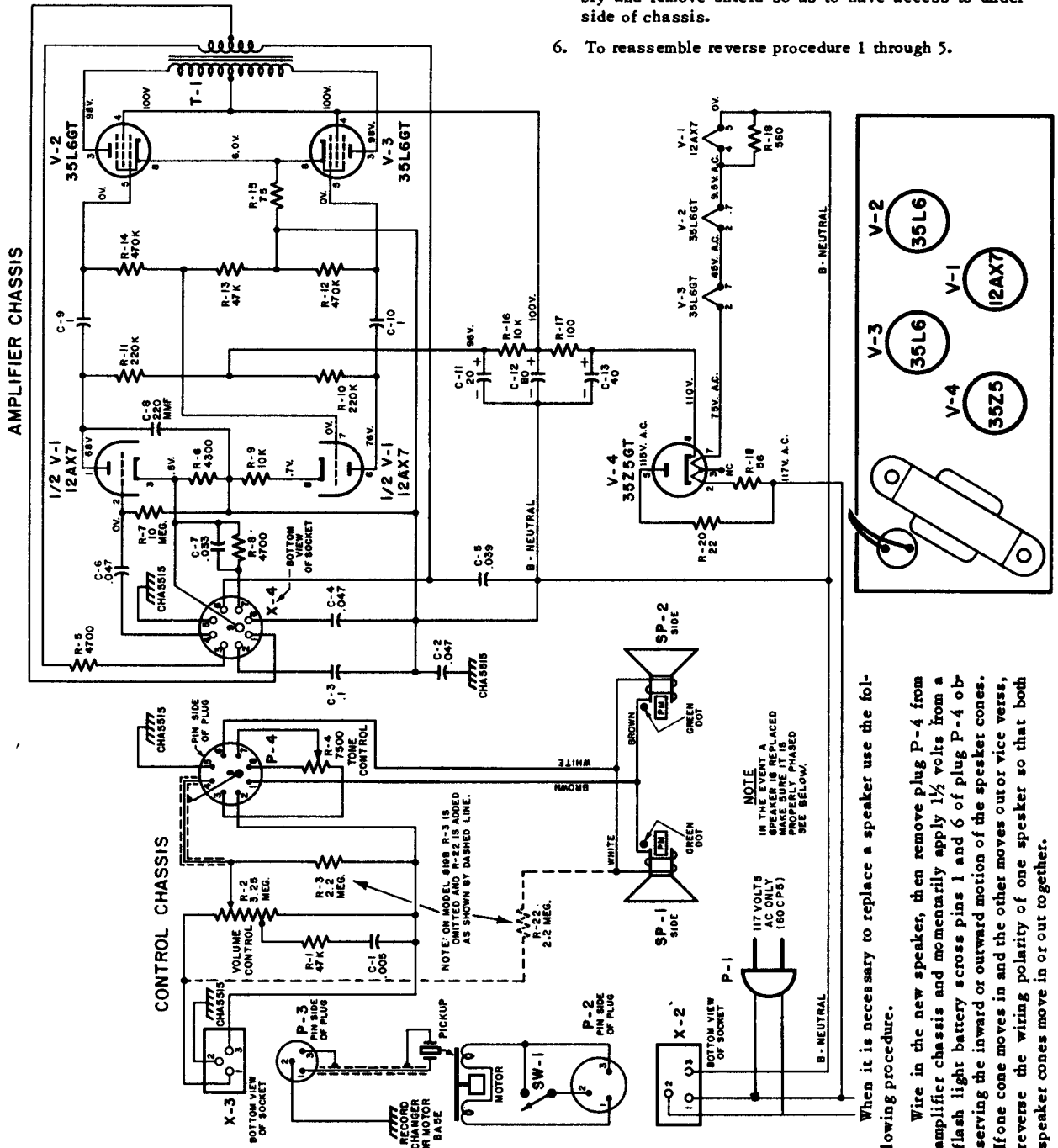

Emerson Radio

MODELS - 825-B
826-B

CHASSIS - 120243-B

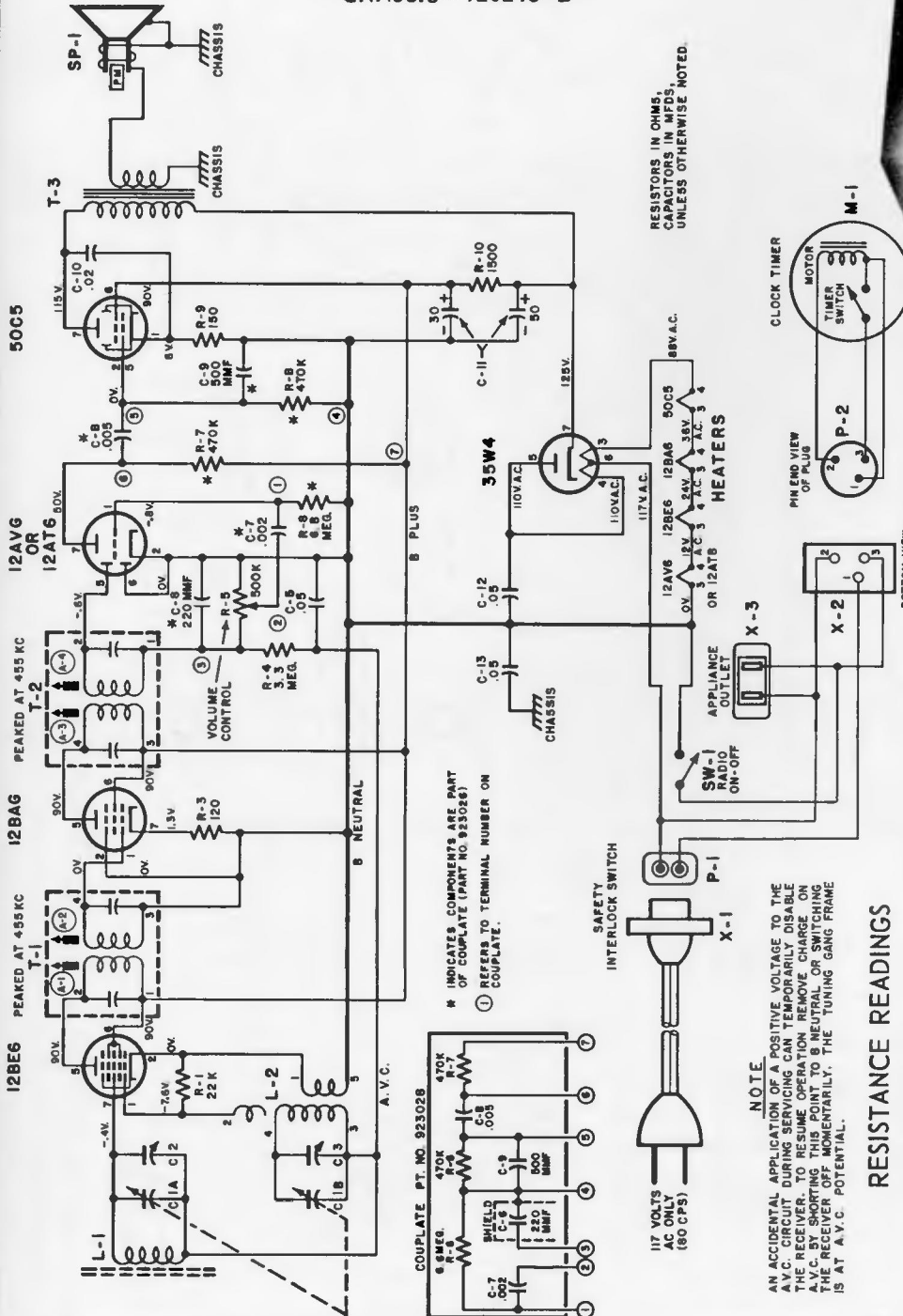

RESISTORS IN OHMS,
CAPACITORS IN MFDS,
UNLESS OTHERWISE NOTED.

NOTE.
AN ACCIDENTAL APPLICATION OF A POSITIVE VOLTAGE TO THE A.V.C. CIRCUIT DURING SERVICING CAN TEMPORARILY DISABLE THE RECEIVER. TO RESUME OPERATION REMOVE CHARGE ON A.V.C. BY SHORTING THIS POINT TO B NEUTRAL OR SWITCHING THE RECEIVER OFF MOMENTARILY. THE TUNING GANG FRAME IS AT A.V.C. POTENTIAL.

RESISTANCE READINGS

TUBE	PIN 1	PIN 2	PIN 3	PIN 4	PIN 5	PIN 6	PIN 7
12BE6	22K	0.8	13	26	1500*	1500*	3.8 MEG
12BA6	15.	0.0	26	39	1500*	1500*	120.
12AV6 or 12AT6	6.8 MEG	0.0	0	13	.5 MEG	0.0	470K*
50C5	150.	470K	39	82	470K	1500*	150*
35W4	N.C.	N.C.	82	115	115	108	0*

1. Voltages indicated are positive d.c., resistances in ohms, unless otherwise indicated.
2. Measurements made with voltohmmyst or equivalent.
3. All measurements taken from pin to B neutral unless otherwise indicated.

* Resistance measured to Pin 7 of Rectifier 35W4 (B+).

Emerson Radio

MODEL - 830B

CHASSIS - 120252-B

TYPE OF TUBES:

- V-1-1R5, converter
- V-2-1U4, i-f amplifier
- V-3-1U5, detector, a.v.c., a-f amp
- V-4-3V4, power output
- V-5-Rectifier, selenium

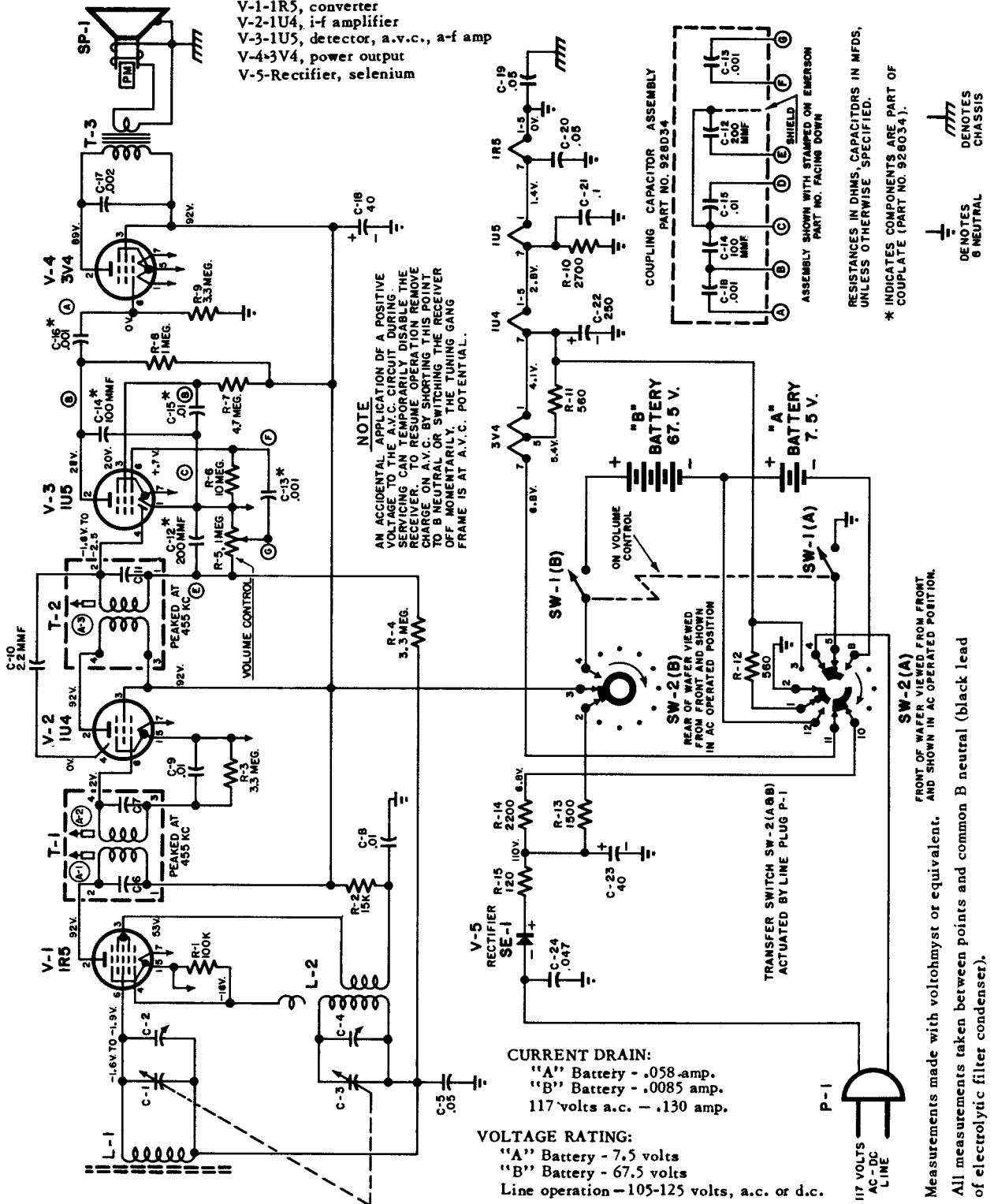

NOTE
 AN ACCIDENTAL APPLICATION OF A POSITIVE VOLTAGE TO THE A.V.C. CIRCUIT DURING SERVICING CAN TEMPORARILY DISABLE THE RECEIVER. TO RESUME OPERATION REMOVE CHASSIS FROM A.V.C. BY SHORTING THIS POINT OFF TEMPORARILY. THE TUNING GANG FRAME IS AT A.V.C. POTENTIAL.

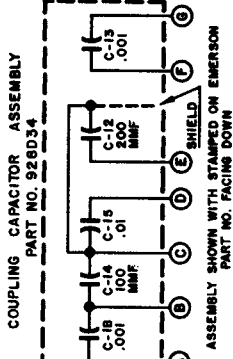

RESISTANCES IN OHMS. CAPACITORS IN MFDS, UNLESS OTHERWISE SPECIFIED.
 * INDICATES COMPONENTS ARE PART OF COUPLATE (PART NO. 926034).

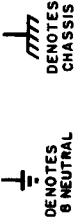

CURRENT DRAIN:
 "A" Battery - .058 amp.
 "B" Battery - .0085 amp.
 117 volts a.c. - .130 amp.

VOLTAGE RATING:
 "A" Battery - 7.5 volts
 "B" Battery - 67.5 volts
 Line operation - 105-125 volts, a.c. or d.c.

Measurements made with voltohmmyst or equivalent.
 All measurements taken between points and common B neutral (black lead of electrolytic filter condenser).

MANUAL OF 1955 MOST-OFTEN-NEEDED RADIO DIAGRAMS

GENERAL ELECTRIC

MODEL 455
TABLE MODEL RADIO RECEIVER

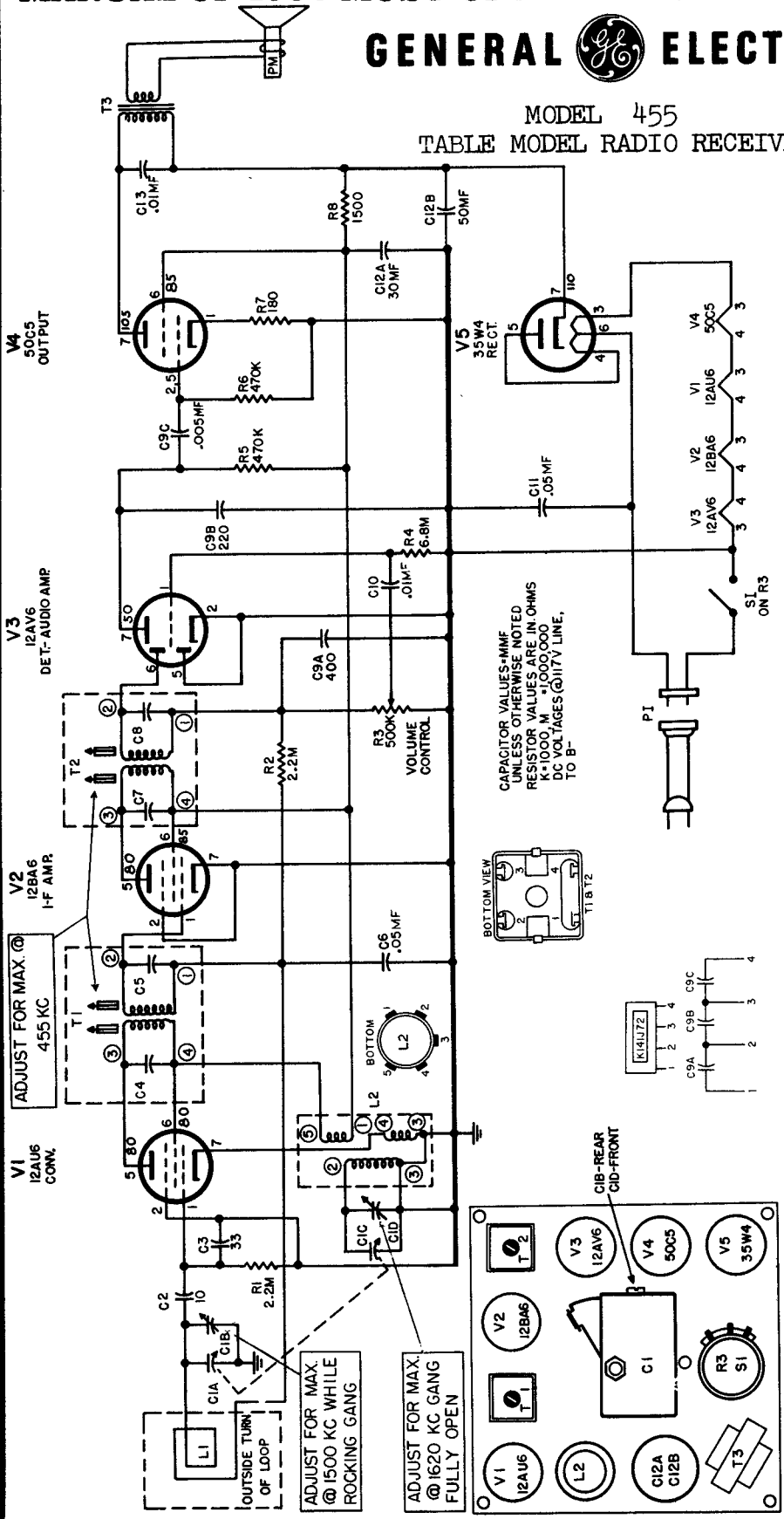

MANUAL OF 1955 MOST-OFTEN-NEEDED RADIO DIAGRAMS

GENERAL ELECTRIC

MODELS 577 AND 578 CLOCK RADIO RECEIVERS

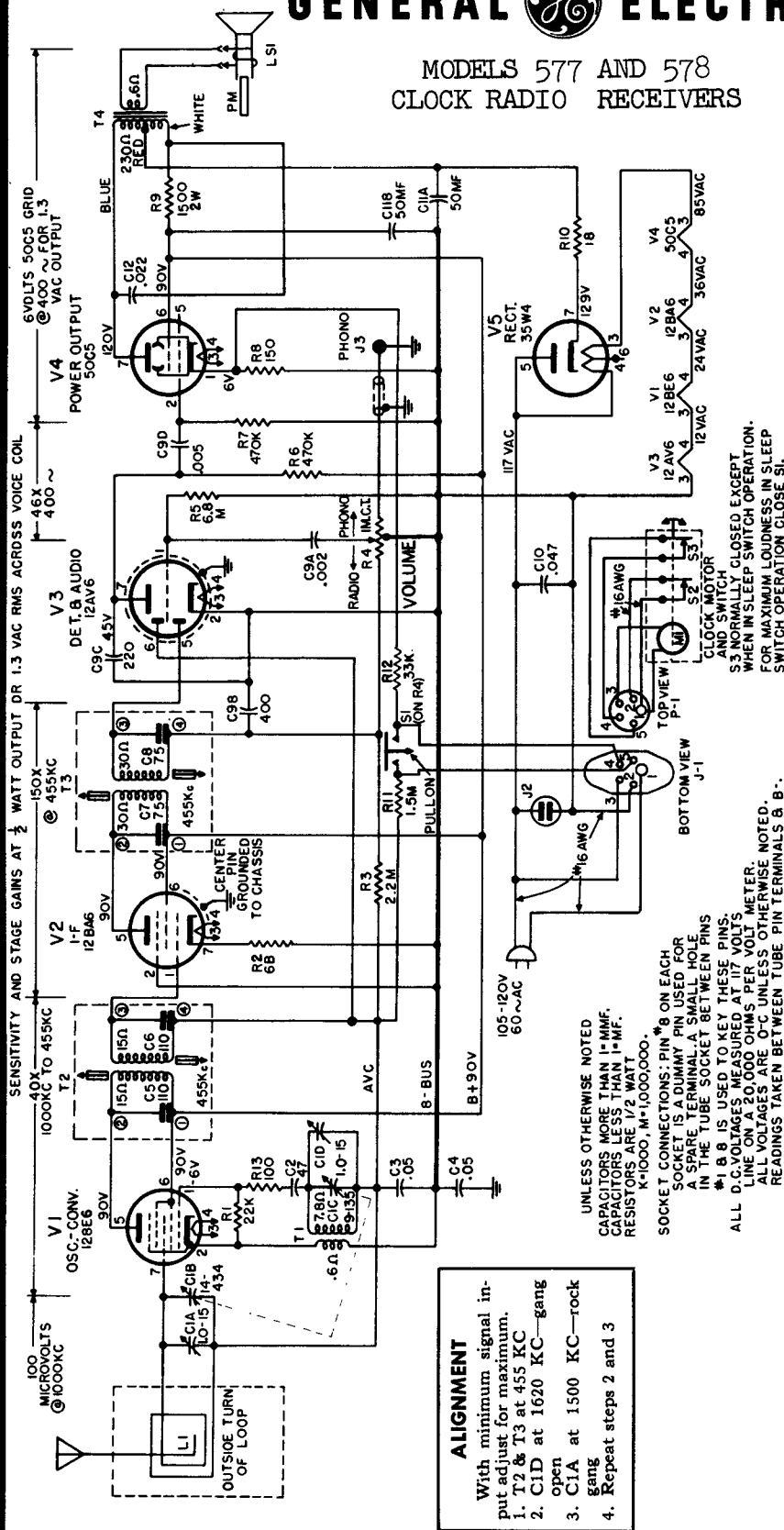

ALIGNMENT

With minimum signal input adjust for maximum.

1. T2 & T3 at 455 KC
2. C1D at 1620 KC—gang open
3. C1A at 1500 KC—rock gang
4. Repeat steps 2 and 3

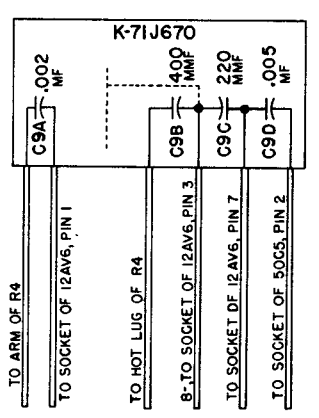
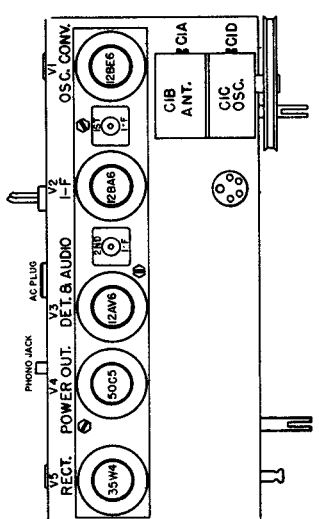
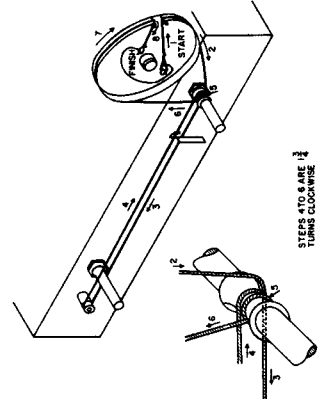

Schematic Diagram, Models 577 and 578

MANUAL OF 1955 MOST-OFTEN-NEEDED RADIO DIAGRAMS

GENERAL ELECTRIC

MODELS 580, 581 AND 582 CLOCK RADIO RECEIVERS

ALIGNMENT CHART

STEP	CONNECT TEST OSCILLATOR TO	TEST OSC. SETTING	TUNING GANG SETTING	ADJUST FOR MAX. OUTPUT
I-F ALIGNMENT				
1	V2, 12BA6 grid (Pin 1) in series with .05 mfd.	455 KC		Cores of second I-F trans. T3
2	V1, 12BE6 grid (Pin 7) in series with .05 mfd.			Cores of first I-F trans. T2
3				Recheck adjustment of T2 and T3.
R-F ALIGNMENT				
4	Inductively coupled to radio loop	1620 KC	Open	C1D
5		1500 KC	For maximum output	C1A*

*Rock tuning for maximum, while adjusting C1A.

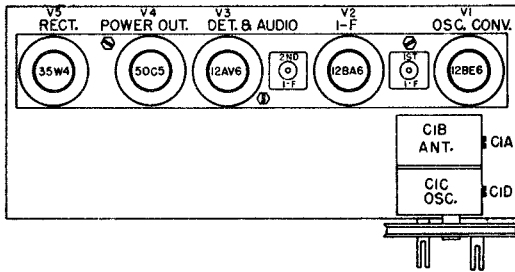

CAT. NO.	SYMBOL	DESCRIPTION
CAPACITORS		
*RCC-126	C16	.047mf., 200 V., paper, 85°C
*RCC-129	C11, C13	.02mf., +40%-10%, 400V, paper
*RCE-166	C15A, B	100-50 mf., 150V., electro.
RCT-079	C1A, B, C, D	Tuning, two-gang
*RCN-053	C12	.047mf., 600 V., paper molded
*RCW-3075	C2	.47mf., ceramic
*RCW-3104	C14A, B	.0068mf., .0005mf., ceramic
*RCW-3137	C9, C10	220mmf., 20%, 400 V., cer.
*UCC-045	C3, 4	.05mf., +40%-10%, 400V., paper

RESISTORS		
RRC-278	R6	Volume control, 4 meg., CT., with switch, S1
*URD-021	R3	68 ohms, 1/2 w. carbon
*URD-025	R2	100 ohms, 1/2 w. carbon
*URD-029	R10	150 ohms, 1/2 w. carbon
*URD-047	R13	820 ohms, 1/2 w. carbon
*URD-065	R12	4700 ohms, 1/2 w. carbon
*URD-077	R14	15,000 ohms, 1/2 w. carbon
*URD-081	R1	22,000 ohms, 1/2 w. carbon
*URD-089	R8, 9	470,000 ohms, 1/2 w., carbon
*URD-109	R5	330,000 ohms, 1/2 w. carbon
*URD-129	R4	2.2 megohm, 1/2 w. carbon
*URD-141	R7	6.8 megohm, 1/2 w. carbon
*URF-053	R11	1500 ohms, 2 w. carbon

COILS AND TRANSFORMERS		
*RLC-122	T1	COIL -Oscillator
*RTL-143	T2, 3	TRANSFORMER -1st or 2nd I-F
*RTD-157	T4	TRANSFORMER -Audio output

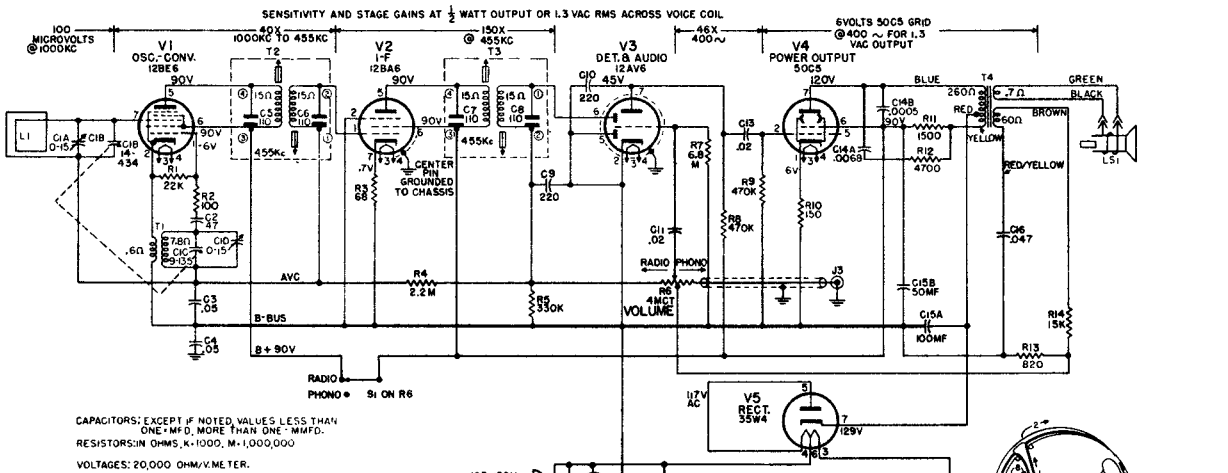

CAPACITORS: EXCEPT IF NOTED, VALUES LESS THAN ONE-MFD. MORE THAN ONE-MMFD.
RESISTORS IN OHMS, K-1000, M-1,000,000
VOLTAGES: 20,000 OHM/V. METER.

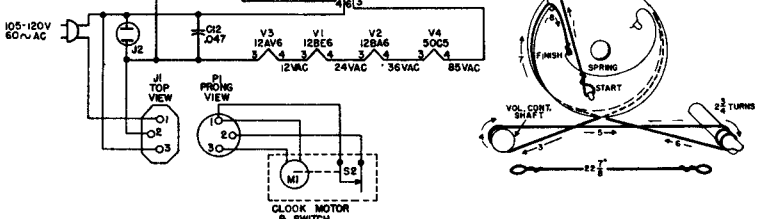
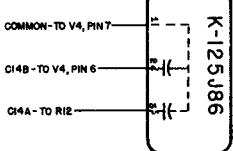

MANUAL OF 1955 MOST-OFTEN-NEEDED RADIO DIAGRAMS

GENERAL ELECTRIC

MODEL 590
(340-1600 KC, 455 KC I-F)

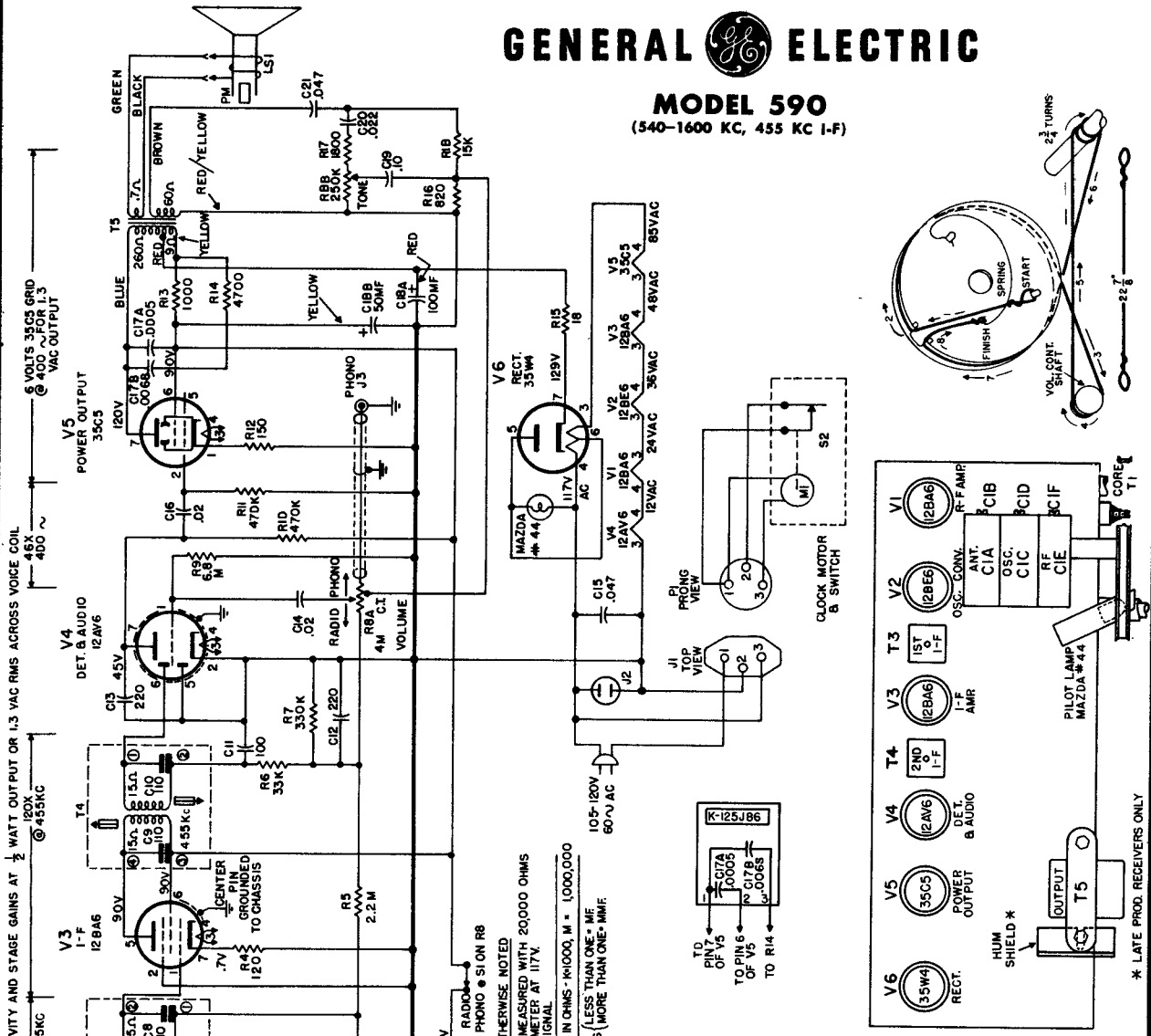

SENSITIVITY AND STAGE GAINS AT 1/2 WATT OUTPUT OR 1.3 VAC RMS ACROSS VOICE COIL
40V @ 455KC
1000KC TO 455KC @ 455KC
10V @ 1000KC

6 VOLTS 35C5 GRID
@ 40V 200 MA
VAC OUTPUT

100 MICROVOLTS
@ 1000KC

UNLESS OTHERWISE NOTED
VOLTAGES MEASURED WITH 20000 OHMS
PER VOLT METER AT 117V
LINE-NO SIGNAL
RESISTORS IN OHMS - K=1000, M = 1,000,000
CAPACITORS (LESS THAN ONE - MF.
MORE THAN ONE - MMF.

ALIGNMENT CHART

Step	Connect Test Oscillator To	Test Oscillator Setting	Receiver Tuning	Adjust for Maximum Output
1	12BA6, V3 grid (pin 1) in series with .05 mf.	455 KC	Minimum capacity	Cores of 2nd i-f transformer T4
2	12BE6, V2 grid (pin 7) in series with .05 mf.	1620 KC	Minimum capacity	Cores of 1st i-f transformer, T3
3	Inductively coupled to radio loop, L1	1500 KC	For maximum	Recheck adjustment of T4 and T3
4		Approximately 600 KC	For maximum. Rock-in with core of T1	C1D, oscillator trimmer
5			For maximum	C1F, r-f trimmer
6			For maximum. Rock-in with core of T1	C1B, antenna trimmer
7			Repeat steps 4, 5, 6 and 7.	Core of r-f transformer, T1. Rock-in with core of receiver tuning.

* LATE PROD. RECEIVERS ONLY

MANUAL OF 1955 MOST-OFTEN-NEEDED RADIO DIAGRAMS

GENERAL ELECTRIC

MODELS 635, 636 AND 637

CABINET: (Plastic)	Model 635-Green; Model 636-Red; Model 637-Gray;	LOUDSPEAKER:	Size 4 inches Type Alnico PM Voice Coil Impedance @ 400 cycles 3.2 ohms
ELECTRICAL RATING: (Batteries only)	"A" Batteries-2 Eveready #964 or Burgess #21R, or equivalent "B" Battery-1 Eveready #437 or Burgess #XX-50, or equivalent.	OPERATING FREQUENCIES:	Tuning Range 540-1600 KC I-F Amplifier 455 KC

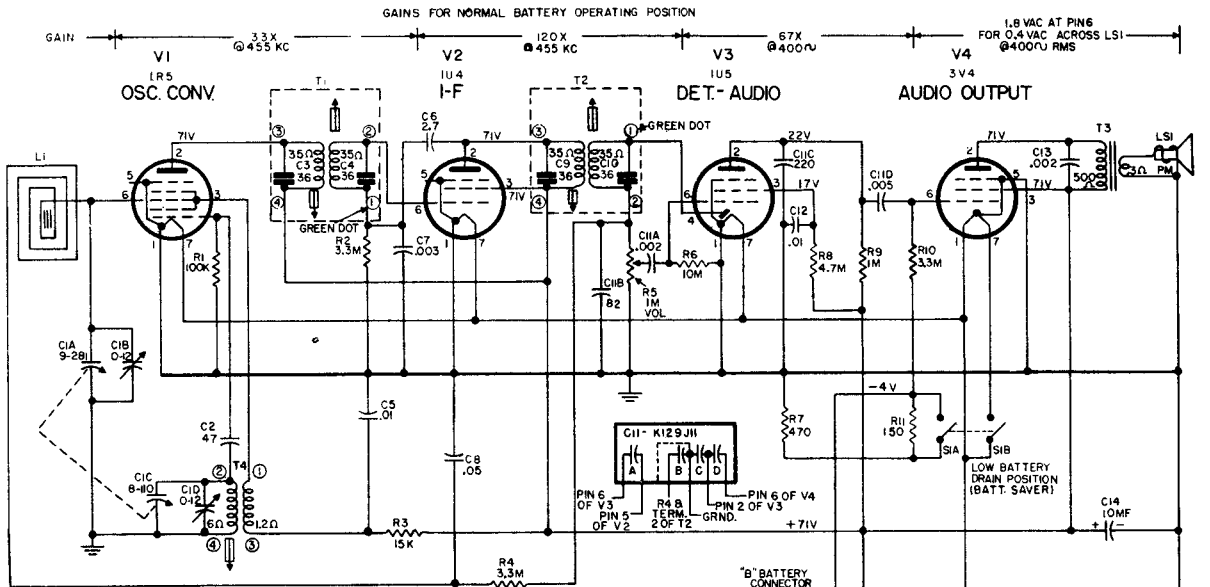

UNLESS OTHERWISE NOTED, CAPACITOR VALUES LESS THAN THE UNIT ARE MF, VALUES MORE THAN 1 ARE MMF.

RESISTANCE VALUES ARE OHMS K=1000 M=1,000,000.

VOLTAGES ARE DC TO CHASSIS GROUND, METER SENSITIVITY 20,000 OHMS/VOLT.

- ALIGNMENT
 I-F - PEAK T1, T2 @ 455 KC
 R-F 1. PEAK CID @ 1620 KC GANG OPEN.
 2. PEAK CIB @ 1500 KC ROCK GANG.
 3. PEAK IRON CORE T4 @ 600 KC ROCK GANG.
 4. REPEAT AS NECESSARY.

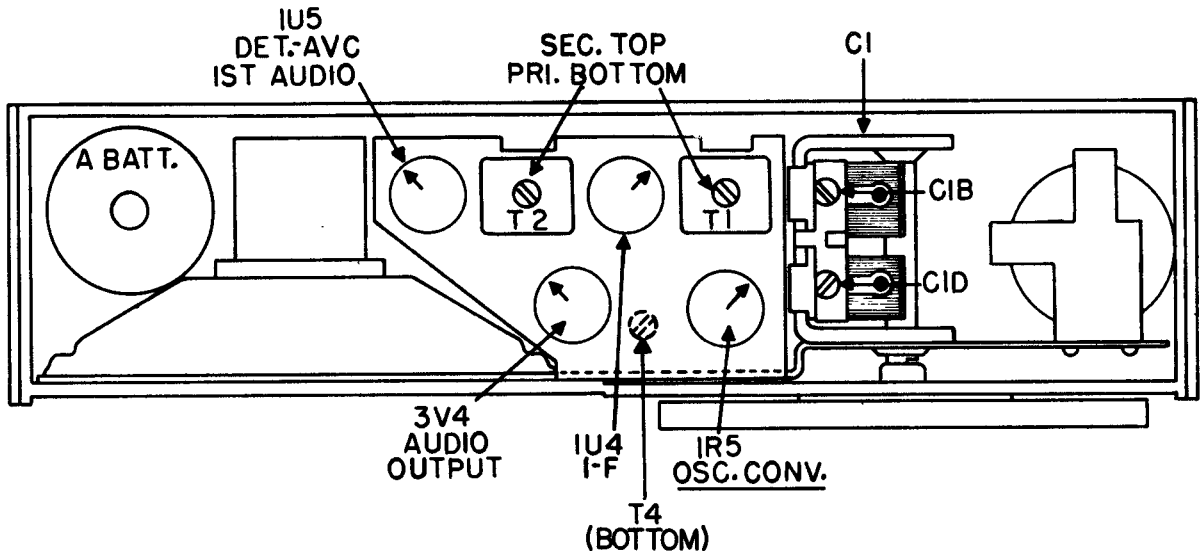
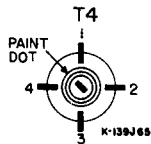

MANUAL OF 1955 MOST-OFTEN-NEEDED RADIO DIAGRAMS

GENERAL ELECTRIC

MODELS 645, 646, 647 and 648
PORTABLE RADIO RECEIVERS

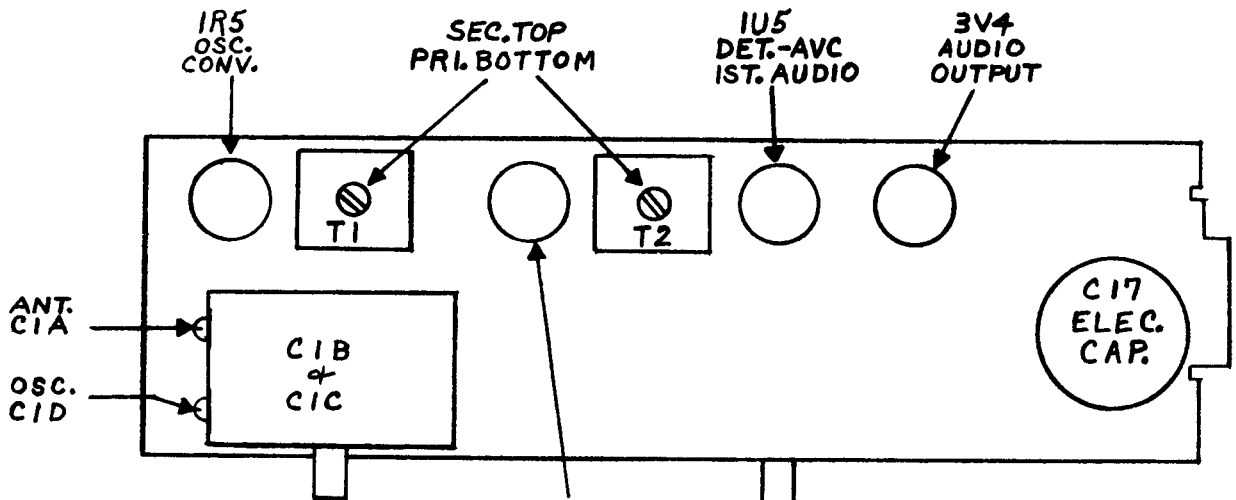
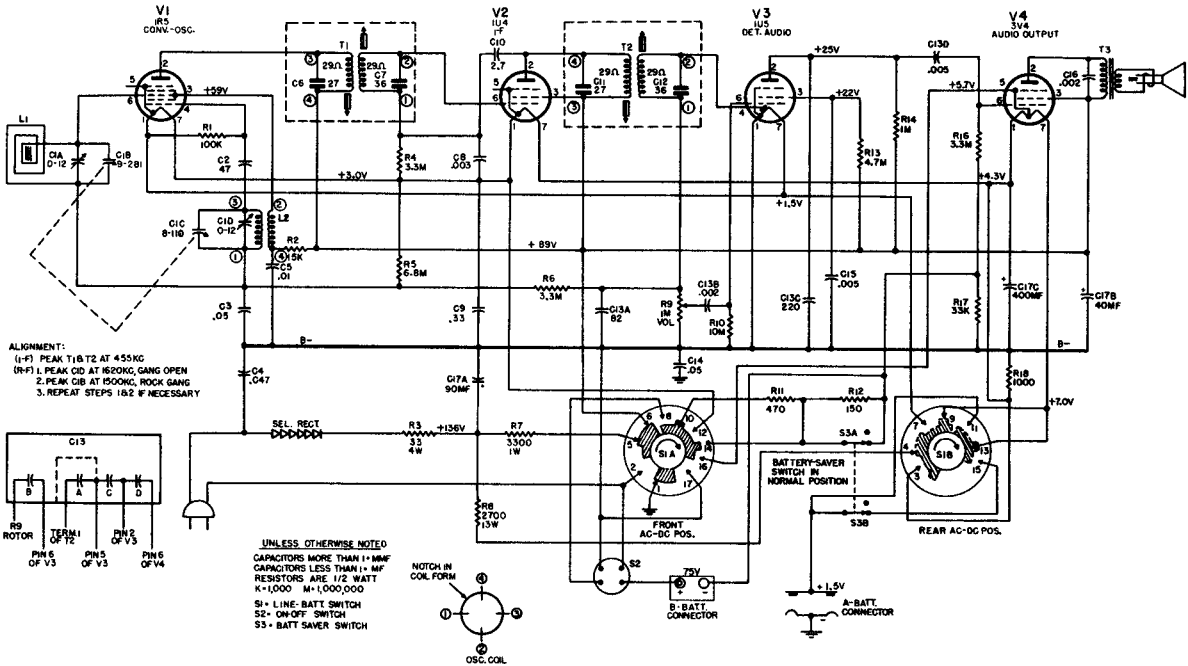

GENERAL INFORMATION

The Models 645, 646, 647 and 648 are four-tube superhetrodyne three-way portable radio receivers. These receivers operate on AC, DC or batteries and incorporate a battery "saver" switch, and the use of a ferrite iron-core antenna.

POWER SUPPLY: 105-120 volts A-C, D-C or "A" Batteries -2 Eveready #950 or equivalent.
 "B" Battery -1 Eveready #467 or equivalent.

AUDIO POWER OUTPUT: 80 milliwatts

LOUDSPEAKER: Size 4 inches
 Type Alnico PM
 Voice Coil Impedance @ 400 cycles 3.2 ohms

OPERATING FREQUENCIES: Tuning Range 540 to 1600 KC
 I-F Amplifier 455 KC

COILS AND TRANSFORMERS

N-RLC-134	L2	COIL -Oscillator
N-RLL-061	L1	ANTENNA ASSEMBLY
RTL-152	T1,2	TRANSFORMER -I-F
N-RT0-171	T3	TRANSFORMER -Output

MANUAL OF 1955 MOST-OFTEN-NEEDED RADIO DIAGRAMS

GENERAL ELECTRIC

MODELS 660 AND 661 CLOCK-RADIO PORTABLE RECEIVERS

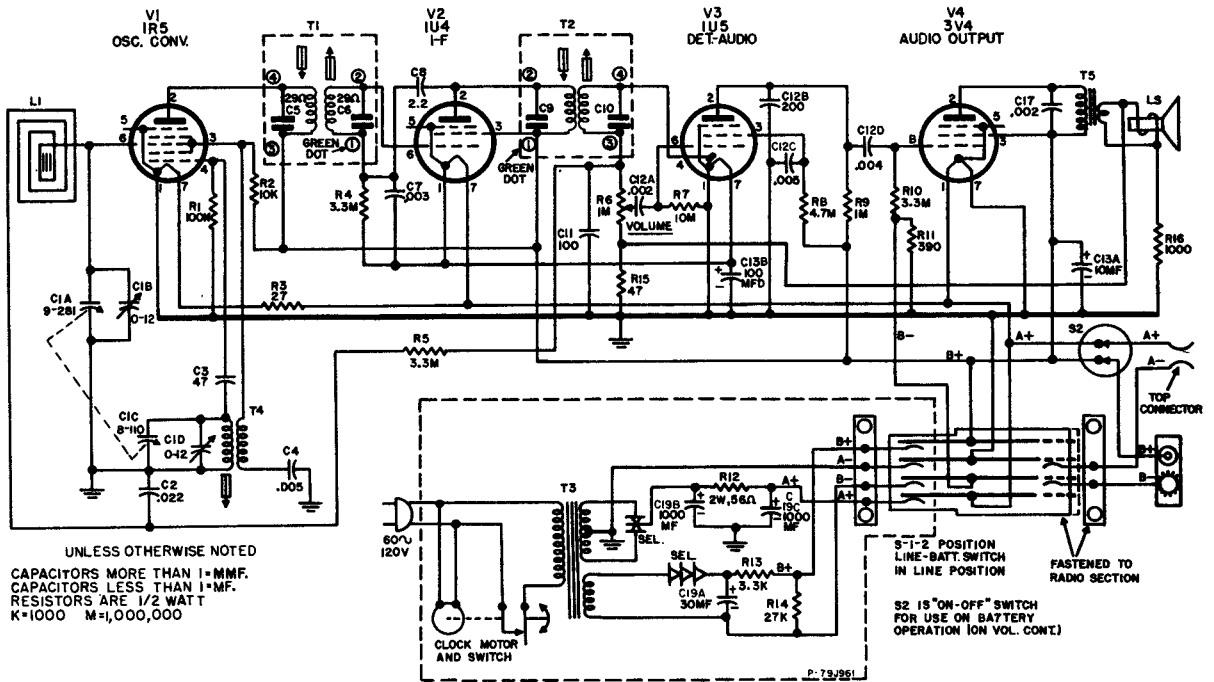

UNLESS OTHERWISE NOTED
CAPACITORS MORE THAN 1-MMF.
CAPACITORS LESS THAN 1-MMF.
RESISTORS ARE 1/2 WATT
K=1000 M=1,000,000

ALIGNMENT

- 1-F PEAK T1, T2 @ 455KC.
- R-F I-PEAK CID @ 162DKC GANG OPEN.
2. PEAK CIB @ 1500KC ROCK GANG.
3. PEAK IRON CORE T4 @ 600KC, ROCK GANG.
4. REPEAT AS NECESSARY.

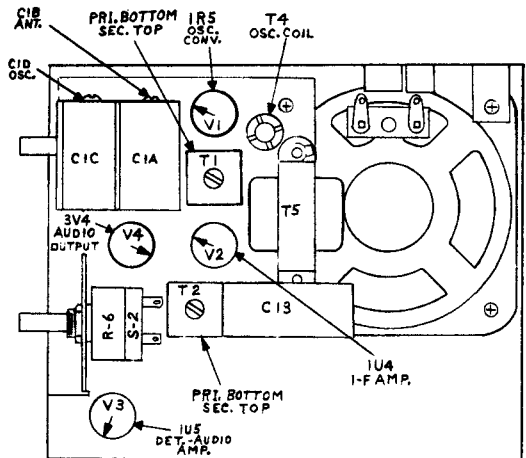
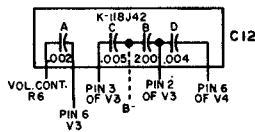

TUBE AND TRIMMER LOCATIONS

CAT. NO.	SYMBOL	DESCRIPTION
CAPACITORS		
N-RCE-213	C13A, B	10 mf., @ 100V., 100 mf., @ 3V., electrolytic
N-RCE-214	C19A, B, C,	30 mf., @ 100V., 1000-1000 mf., @ 15V., electrolytic
RCC-123	C2	.022 mf., paper
RCN-039	C8	2.2 mf., 20%, 500V
N-RCT-086	C1A, B, C, D	Tuning capacitor, two gang
RCW-3014	C4	5000 mf., ceramic
RCW-3018	C17	2000 mf., ceramic
RCW-3075	C3	47 mf., ceramic
RCW-3079	C11	100 mf., ceramic
RCW-3089	C12A, B, C, D	Bullplate -.002 mf., 200 mf., .005 mf., .004 mf.
RCW-3118	C7	3000 mf., ceramic

RESISTORS (10%, 1/2 W. CARBON)

URD-011	R3	27 ohms
URD-017	R15	47 ohms
URD-039	R11	390 ohms
URD-049	R16	1,000 ohms
URD-061	R13	3,300 ohms
URD-073	R2	10K
URD-083	R14	27K
URD-097	R1	100K
URD-121	R9	1 megohm
URD-133	R4, 5, 10	3.3 megohms
URD-137	R8	4.7 megohms
URD-145	R7	10 megohms
URR-019	R12	56 ohms, 2 W

POTENTIOMETER

N-RRC-322	R6, S2	Volume control & switch, 1 megohm
-----------	--------	-----------------------------------

SPECIFICATIONS	
CABINET: (Plastic)	Model 660 - Two-tone gray Model 661 - Red and Antique White
ELECTRICAL RATING:	105 to 120 volts AC (clock power supply) "A" Batteries - 2 Eveready #950 or equivalent "B" Battery - 1 Eveready #467 or equivalent
AUDIO POWER OUTPUT:	70 milliwatts at 10% distortion 150 milliwatts maximum output
LOUDSPEAKER:	Size 3 1/2 inches Type Alnico PM VoiceCoil Impedance @ 400 cycles 3.2 ohms
OPERATING FREQUENCIES:	Tuning Range 540-1600 KC I-F Amplifier 455 KC

MANUAL OF 1955 MOST-OFTEN-NEEDED RADIO DIAGRAMS

the hallicrafters co.

MODELS TW-55 & B-55

(Run 1)

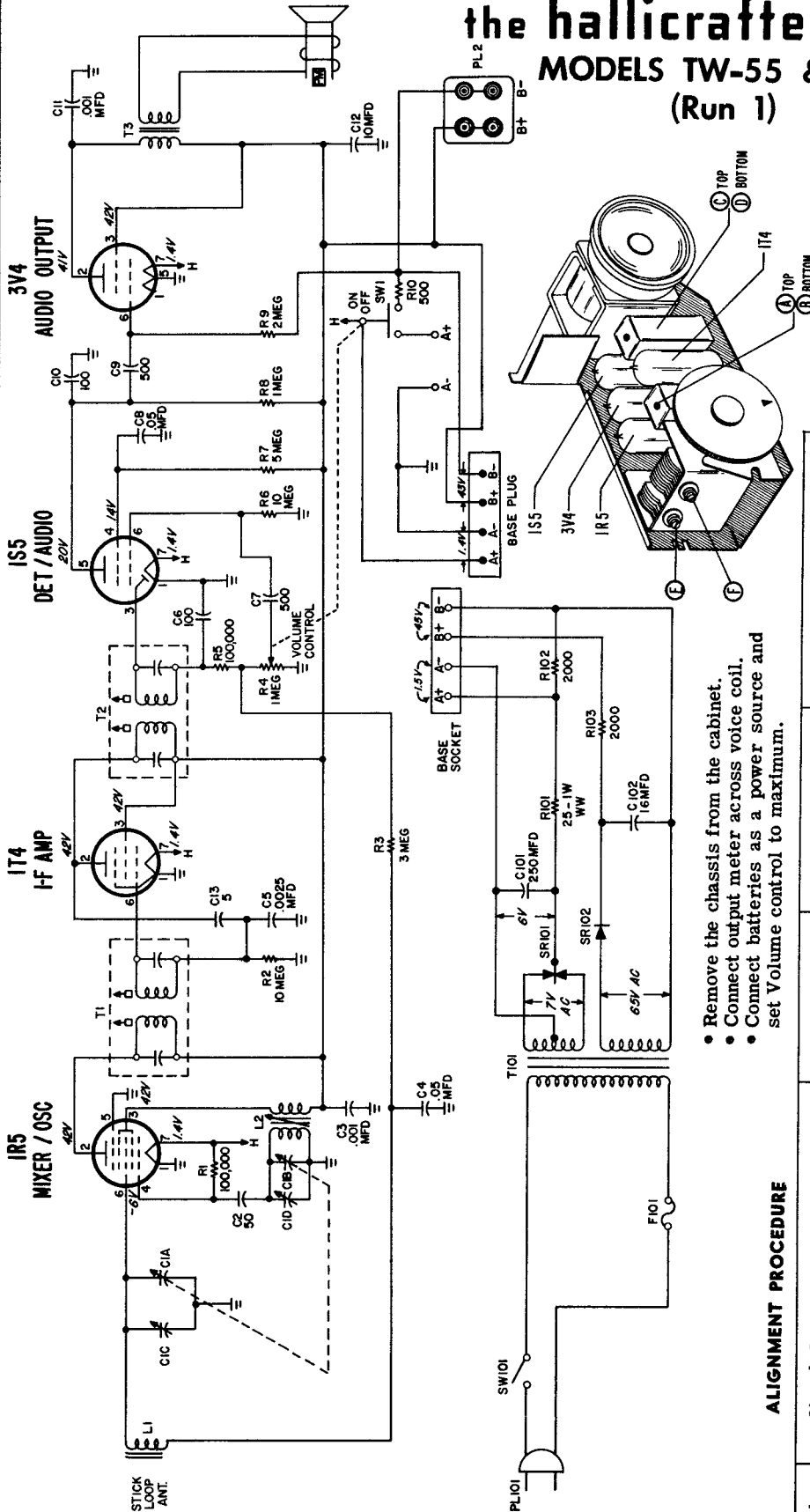

- Remove the chassis from the cabinet.
- Connect output meter across voice coil.
- Connect batteries as a power source and set Volume control to maximum.

ALIGNMENT PROCEDURE

Step	Signal Generator Connections	Generator Frequency	Receiver Dial Setting	Adjust for Maximum Output
1	High side through .1 mfd. capacitor to stator plates of osc. section of tuning gang. Low side to chassis.	460 KC	Gang Half-Meshed	A, B, C, & D
2	Place the chassis in the cabinet and connect the built-in antenna leads. Slide the small panel from the side of the cabinet adjacent to the tuning gang to gain access to the remaining adjustments.	1240 KC	1240 KC (highest freq. CD emblem on the dial)	E, osc. trimmer & F, ant. trimmer
3	Loosely couple the generator to the built-in antenna. (a few turns of wire wrapped around the handle will be satisfactory)	1240 KC		

NOTES

1. Resistances indicated in ohms and capacitance in mfd. unless otherwise specified. K = 1000.
2. Resistors have 1/10 watt rating unless otherwise specified. (Replace with 1/2 watt)
3. Voltage readings taken under the following conditions:
 - A. All voltage readings are DC and positive unless otherwise noted.
 - B. TW-55 voltages measured to chassis unless otherwise indicated.
 - C. B-55 voltages measured between point indicated.
 - D. All B-55 readings were taken while connected to the receiver with the receiver operating.
 - E. Line voltage set to 110V 60°CAC and readings taken on a VTVM.

MANUAL OF 1955 MOST-OFTEN-NEEDED RADIO DIAGRAMS

the hallicrafters co.

MODELS 5R60 AND 5R61
AC DC RADIO RECEIVER

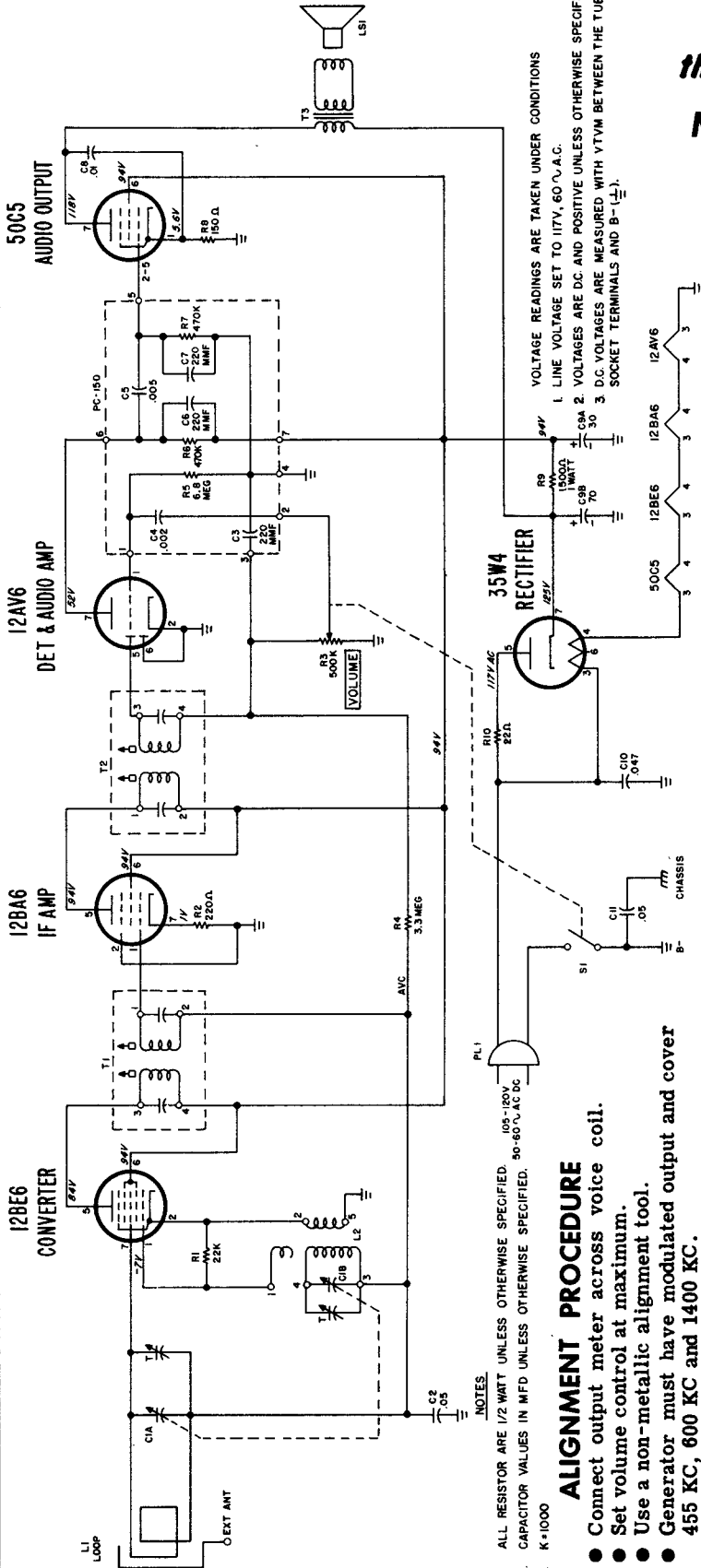

Step	Signal Generator Connections	Generator Frequency	Receiver Dial Setting	Adjust
1	High side through .01 mfd. capacitor to pin 7 of V1. Low side to B-.	455 KC	Gang fully open	A and B (2nd I-F) C and D (1st I-F)
2	Radiate signal generator into loop antenna.	1400 KC	1400 KC	E (Oscillator trimmer) F (Antenna Trimmer)
3	Same as step 2.	600 KC	600 KC	Knife outside plates of C1B if required.

Repeat steps 2 & 3

MANUAL OF 1955 MOST-OFTEN-NEEDED RADIO DIAGRAMS

hallicrafters

MODEL 5R24

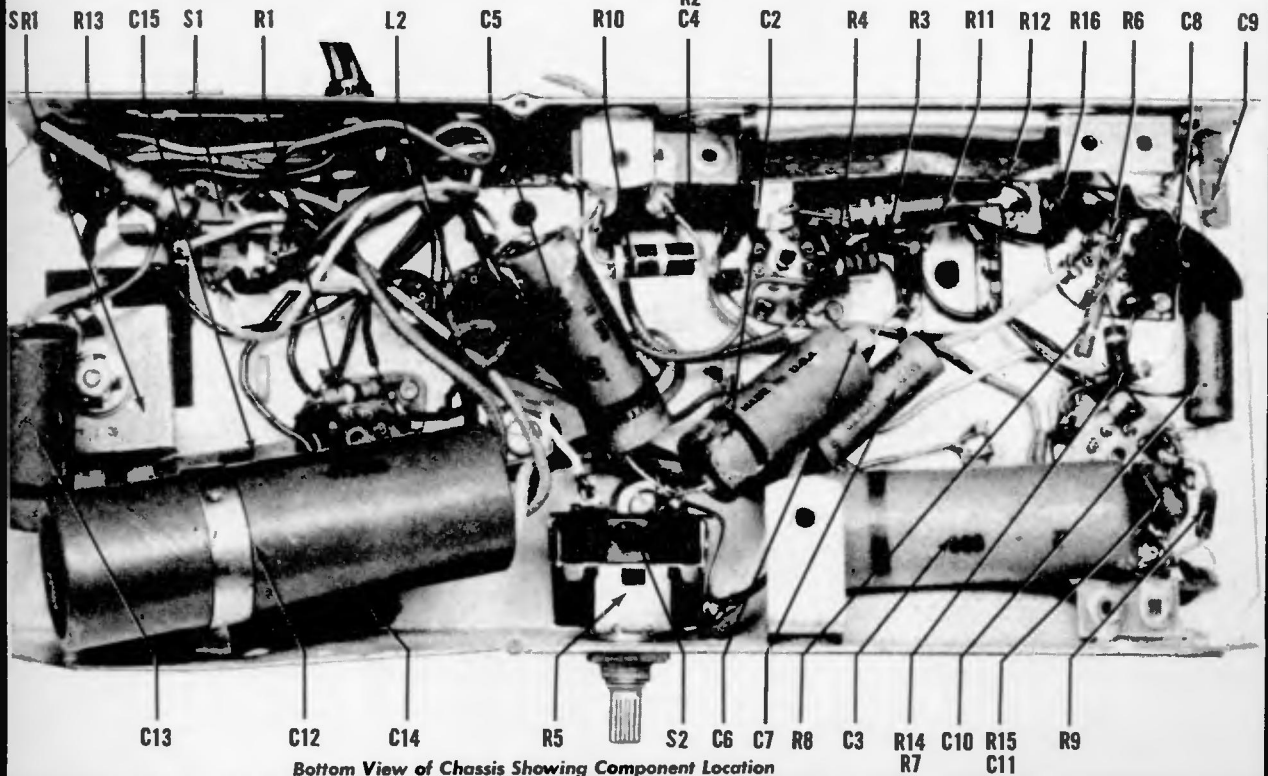
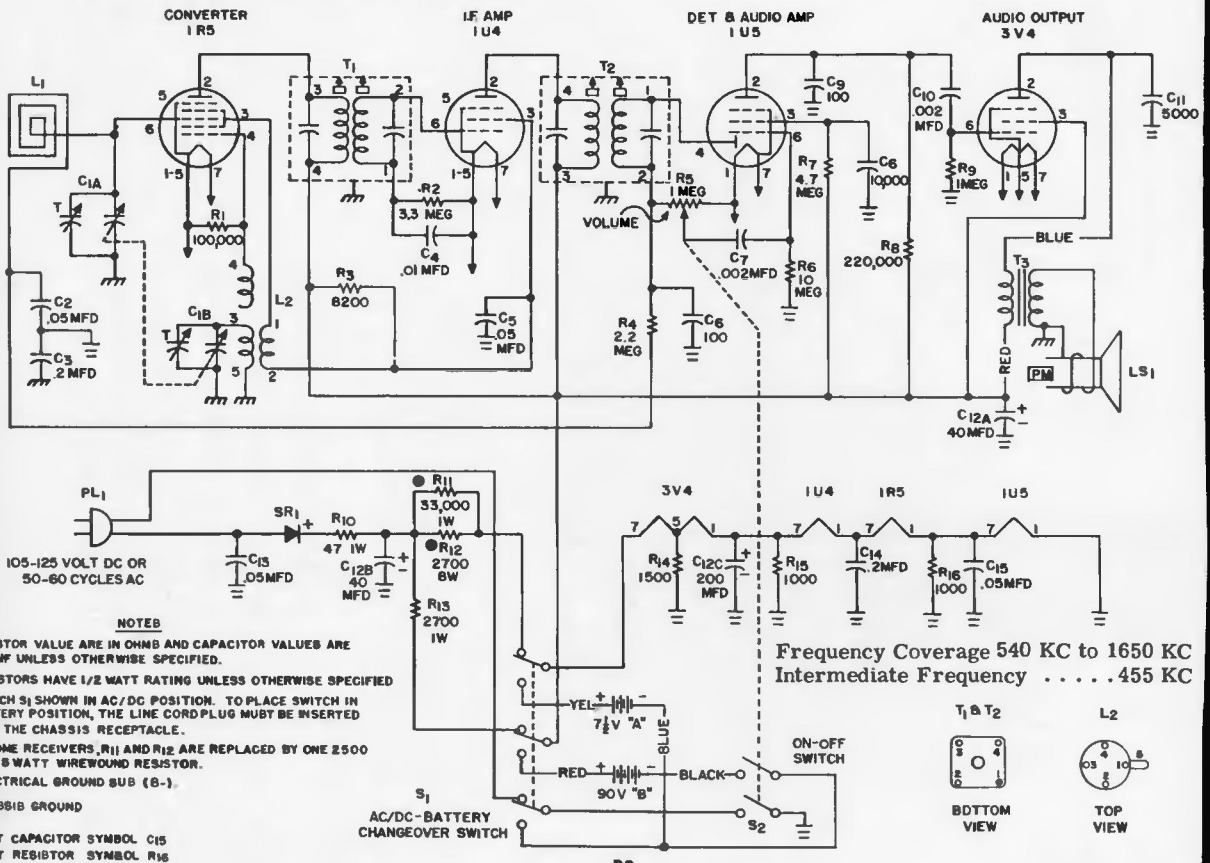

Bottom View of Chassis Showing Component Location

MANUAL OF 1955 MOST-OFTEN-NEEDED RADIO DIAGRAMS

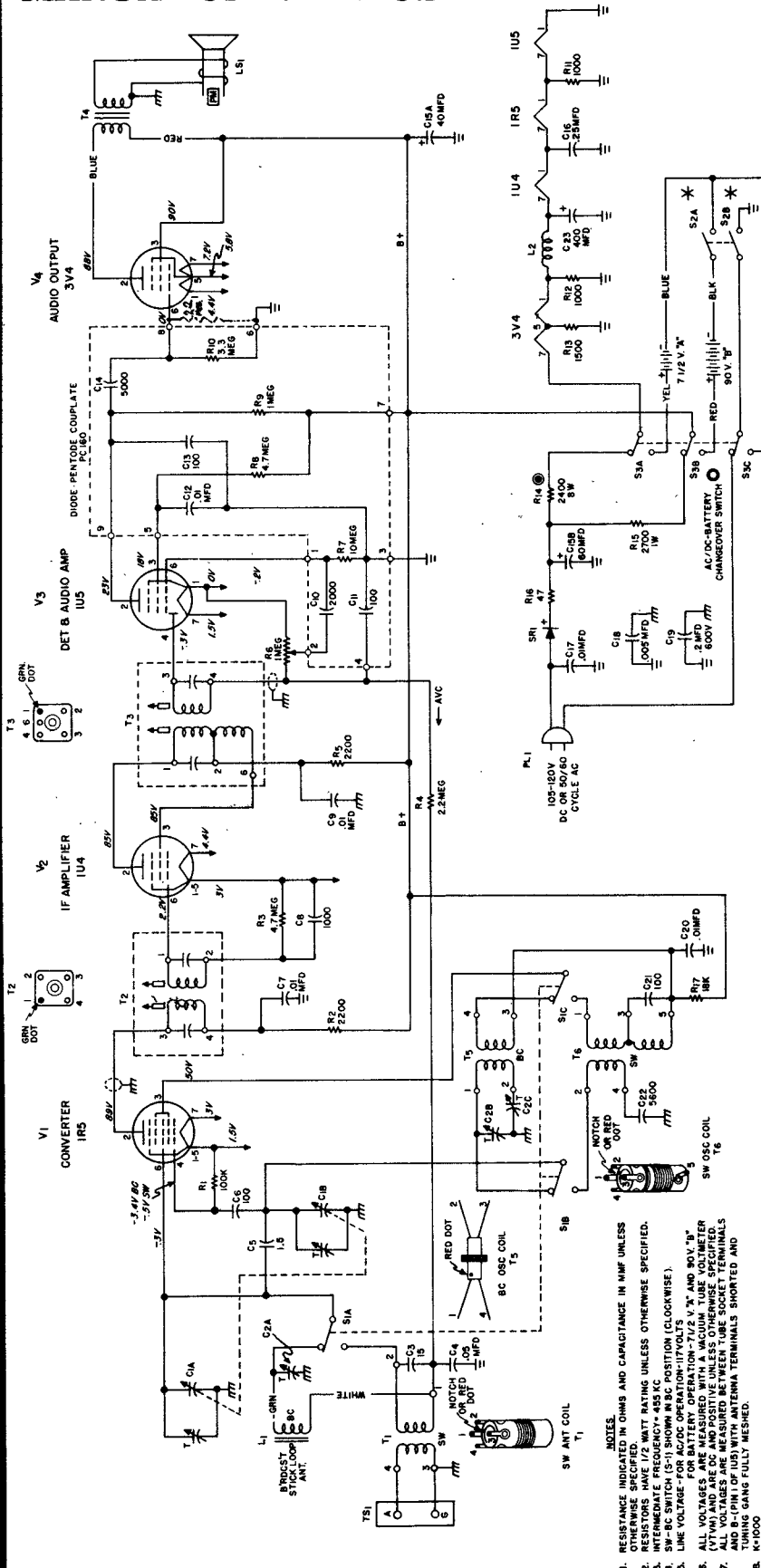

VALUES AND TOLERANCES SHOWN ARE NOMINAL AND VARIATIONS MAY BE FOUND. IT IS RECOMMENDED THAT THE VALUE OF PARTS BEING REPLACED CORRESPOND TO THE NOMINAL VALUE OF THE PART BEING REPLACED.

- NOTES:**
1. RESISTANCE INDICATED IN OHMS AND CAPACITANCE IN MMF UNLESS OTHERWISE SPECIFIED.
 2. RESISTORS HAVE 1/2 WATT UNLESS OTHERWISE SPECIFIED.
 3. INTERMEDIATE FREQUENCY - 455 KC
 4. SW-BC SWITCH (S-1) SHOWN IN BC POSITION (CLOCKWISE).
 5. LINE VOLTAGE FOR BATTERY OPERATION - 7 1/2 V. " AND 90V. "B"
 6. ALL VOLTAGES ARE MEASURED WITH A VACUUM TUBE VOLTMETER (VTVM) AND ARE DC AND POSITIVE UNLESS OTHERWISE SPECIFIED.
 7. ANTENNA TERMINALS SHOWN SHORTED AND TUNING GANG FULLY MESHED.
 8. K-1000 SETS, R-14 IS REPLACED BY (1) 5700 OHM 1/2 WATT 5% RESISTOR AND (2) 220 OHM 1 WATT RESISTOR CONNECTED IN PARALLEL.
 - * PART OF VOLUME CONTROL RE.
 - ± (COMMON GROUND)
 - ⊥ CHASSIS

DIAL CORD STRINGING - Set the tuning capacitor in a fully meshed position. Tie one end of a 30-inch length of 30 lb. test dial cord to the tension spring at position 1 as shown in Fig. 4. Follow the stringing procedure 1 through 8. At position 8, stretch the spring and tie the cord securely to the spring. Cut off the loose ends of the cord and apply a drop of quick drying cement to the knot. With the tuning capacitor fully meshed, align the pointer so that it points vertically downward.

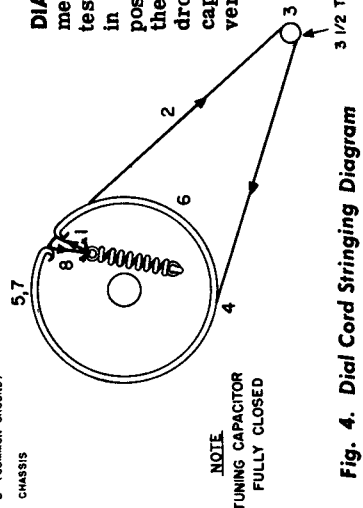

Fig. 4. Dial Cord Stringing Diagram

○ SWITCH S3 SHOWN IN AC/DC POSITION. TO PLACE SWITCH IN BATTERY POSITION, INSERT LINE CORD PLUG INTO CHASSIS RECEPTACLE.

- Power Supply** .. 105-120 volts DC/50-60 cycle
AC or 90 and 7 1/2 volt batteries
Frequency Coverage... BC - 535 to 1620 KC
Intermediate Frequency 455 KC
Speaker 4-inch PM
Voice Coil Impedance 3.2 ohms
Antenna
 BC - Built-in stick loop
 SW - Terminals for single wire or doublet

The Hallicrafters Co. Models 5R40, 5R41, and 5R42

MANUAL OF 1955 MOST-OFTEN-NEEDED RADIO DIAGRAMS

MAJESTIC RADIO AND TELEVISION
DIVISION OF THE WILCOX-GAY CORPORATION

MODEL 4L1 - SCHEMATIC DIAGRAM

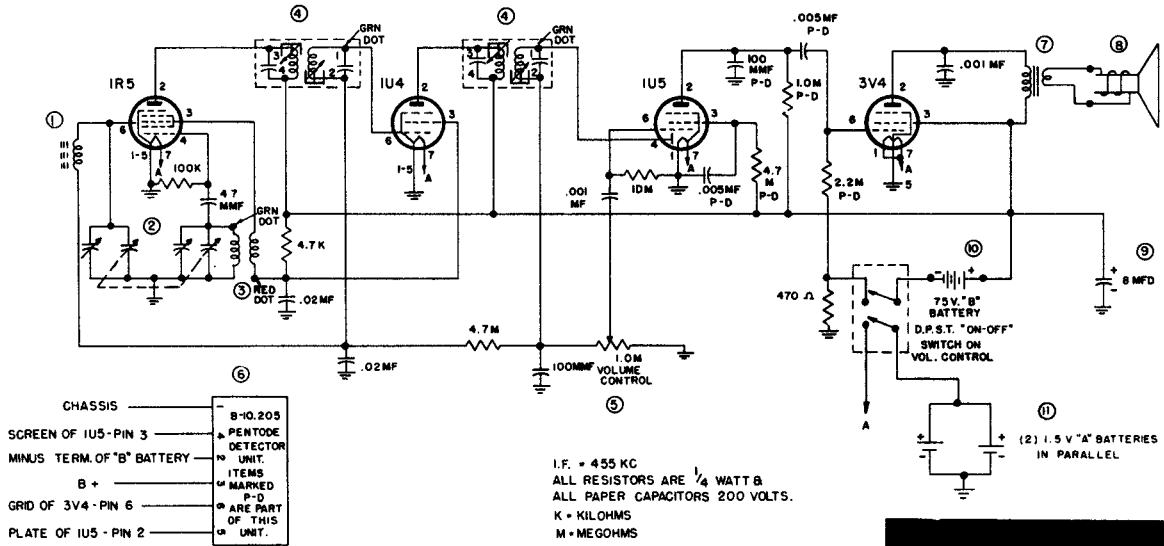

CHASSIS — B-10.205
SCREEN OF 1U5 - PIN 3 — PENTODE DETECTOR UNIT.
MINUS TERM. OF "B" BATTERY — ITEMS MARKED WITH "P-D" ARE PART OF THIS UNIT.
B + —
GRID OF 3V4 - PIN 6 —
PLATE OF 1U5 - PIN 2 —

I.F. = 455 KC
ALL RESISTORS ARE 1/4 WATT &
ALL PAPER CAPACITORS 200 VOLTS.
K = KILOHMS
M = MEGOHMS

PART NO.	DESCRIPTION
① C-1.600	FERRITE ROD ANTENNA
② C-2.227	2 GANG VARIABLE CONDENSER
③ C-1.601	OSCILLATOR COIL
④ C-1.445-5	I.F. TRANSFORMER
⑤ C-9.233	VOLUME CONTROL & DPST SWITCH
⑥ B-10.205	PENTODE DETECTOR COUPLATE
⑦ C-9.380-1	OUTPUT TRANSFORMER

PART NO.	DESCRIPTION
⑧ C-30.339 OR C-30.446	P M SPEAKER
⑨ B-5.544 OR B-5.417	ELECTROLYTIC CAP. 8MFD, 70V, 75V "B" BATTERY, "EVEREADY" T TYPE NO.437, OR EQUIV.
⑩	D.P.S.T. "ON-OFF" SWITCH ON VOL. CONTROL
⑪	2 - 1.5V "A" BATTERIES, "EVEREADY" TYPE NO. 964,

MODEL 4L1

MODEL 5M1 - SCHEMATIC DIAGRAM

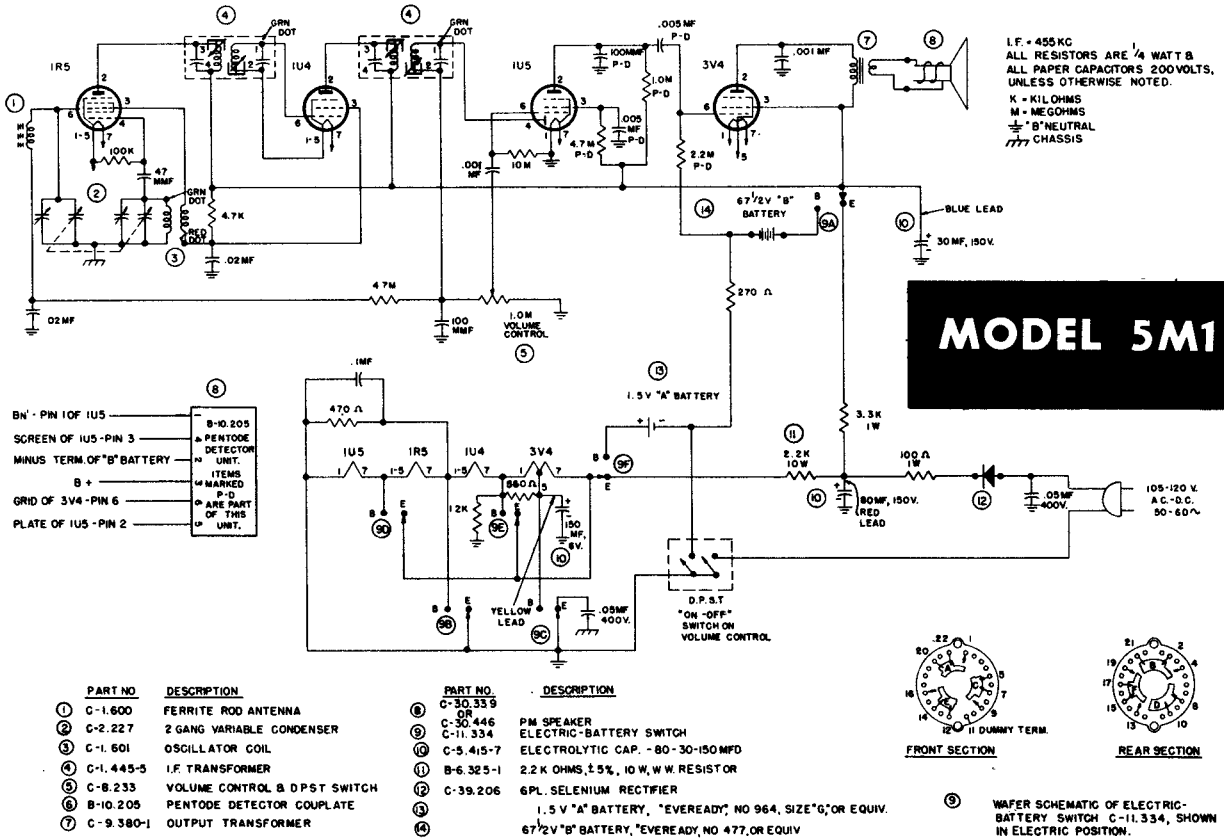

B+ - PIN 1 OF 1U5 —
SCREEN OF 1U5 - PIN 3 — PENTODE DETECTOR UNIT.
MINUS TERM. OF "B" BATTERY — ITEMS MARKED WITH "P-D" ARE PART OF THIS UNIT.
B + —
GRID OF 3V4 - PIN 6 —
PLATE OF 1U5 - PIN 2 —

I.F. = 455 KC
ALL RESISTORS ARE 1/4 WATT &
ALL PAPER CAPACITORS 200 VOLTS,
UNLESS OTHERWISE NOTED.
K = KILOHMS
M = MEGOHMS
1/2 "B" NEUTRAL
// CHASSIS

PART NO.	DESCRIPTION
① C-1.600	FERRITE ROD ANTENNA
② C-2.227	2 GANG VARIABLE CONDENSER
③ C-1.601	OSCILLATOR COIL
④ C-1.445-5	I.F. TRANSFORMER
⑤ C-9.233	VOLUME CONTROL & DPST SWITCH
⑥ B-10.205	PENTODE DETECTOR COUPLATE
⑦ C-9.380-1	OUTPUT TRANSFORMER

PART NO.	DESCRIPTION
⑧ C-30.339 OR C-30.446	P M SPEAKER
⑨ C-11.334	ELECTRIC-BATTERY SWITCH
⑩ C-5.415-7	ELECTROLYTIC CAP. - 80-30-150MFD
⑪ B-6.325-1	2.2K OHMS ± 5%, 10W, W W RESISTOR
⑫ C-39.206	6PL. SELENIUM RECTIFIER
⑬	1.5V "A" BATTERY, "EVEREADY", NO 964, SIZE "G", OR EQUIV.
⑭	67.2V "B" BATTERY, "EVEREADY", NO 477, OR EQUIV.

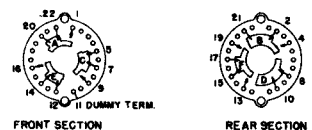

⑬ WAFER SCHEMATIC OF ELECTRIC-BATTERY SWITCH C-11.334, SHOWN IN ELECTRIC POSITION.

MANUAL OF 1955 MOST-OFTEN-NEEDED RADIO DIAGRAMS

Montgomery Ward

Models
GSL-1614A, GSL-1615A
GSL-1616A, GSL-1617A

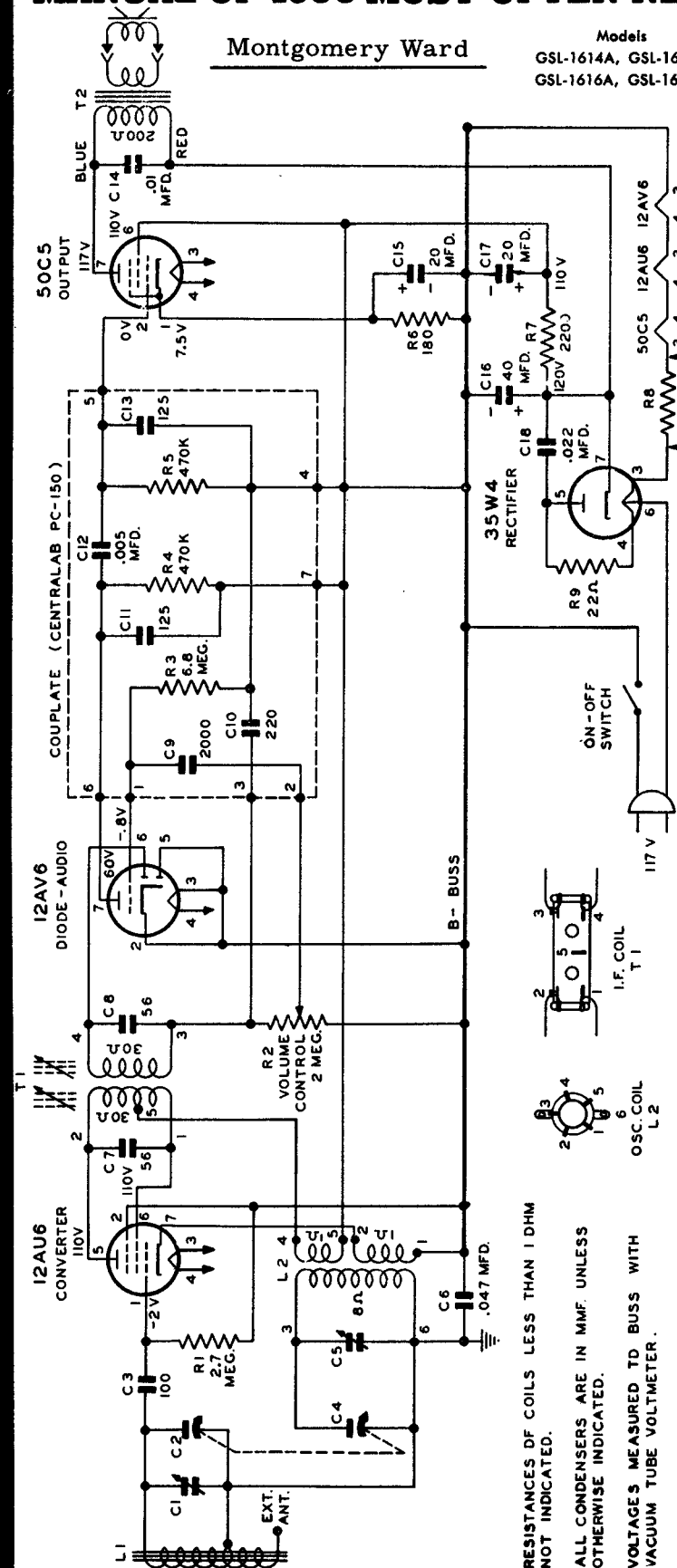

RESISTANCES OF COILS LESS THAN 1 OHM NOT INDICATED.
ALL CONDENSERS ARE IN MMF. UNLESS OTHERWISE INDICATED.
VOLTAGES MEASURED TO BUSS WITH VACUUM TUBE VOLTMETER.

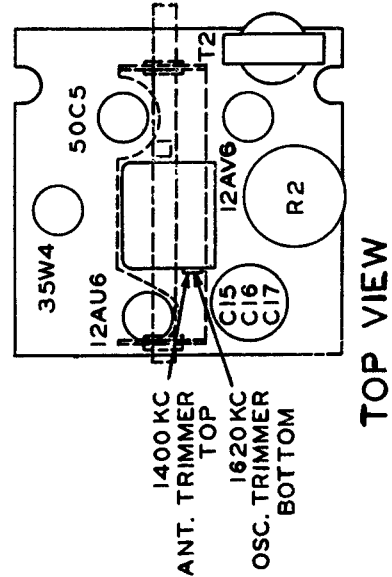

TOP VIEW

FREQUENCY	SIGNAL GENERATOR			TUNER SETTING	ADJUST FOR MAXIMUM OUTPUT
	COUPLING CAPACITOR	CONNECTION TO RADIO	GROUND CONNECTION		
455 Kc	.05 Mfd.	Rear stator plates of tuning condenser.	B Minus Buss Lead	Any point near center where no interfering signal is received.	Slugs at top of I. F. Coil T-1.
1620 Kc	.05 Mfd.	Rear stator plates of tuning condenser.	B Minus Buss Lead	Exactly 1620 Kc.	Oscillator trimmer of Gang. (C5)
1400 Kc	—	Lay Generator lead near back of cabinet.	B Minus Buss Lead	Exactly 1400 Kc.	Antenna trimmer of Gang. (C1)

Motorola

MODELS

- 54X1** MAHOGANY
- 54X2** IVORY
- 54X3** LEAF GREEN

CHASSIS

HS-432

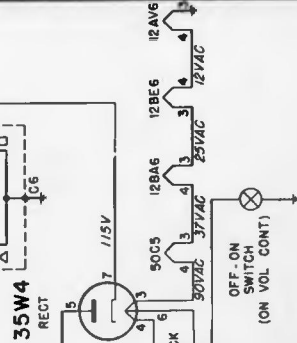
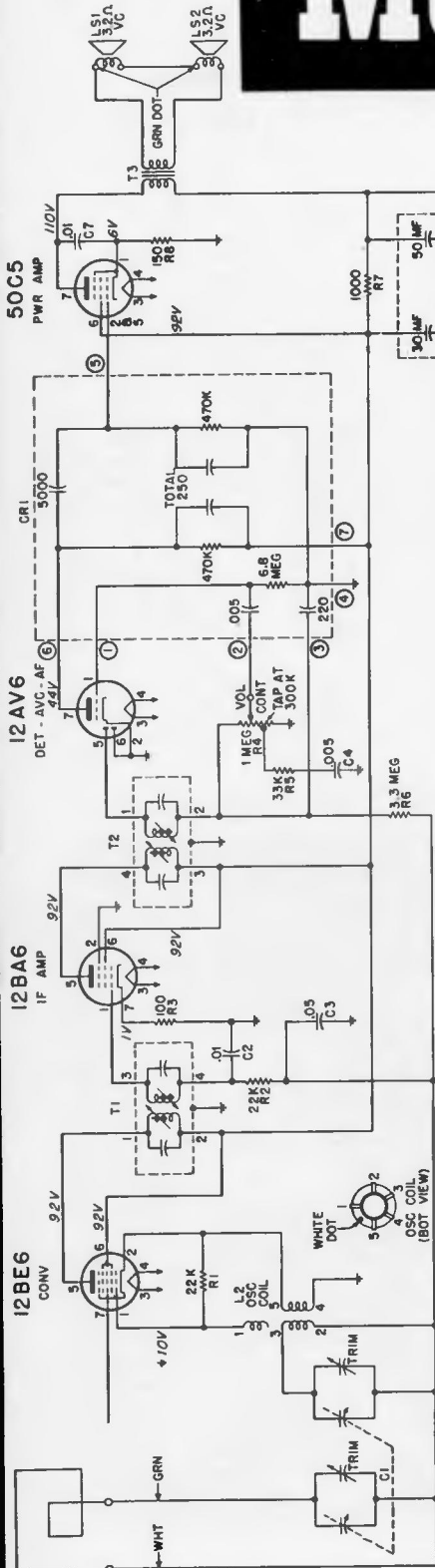

NOTES:
 CAPACITORS - DECIMAL VALUES IN MF, ALL OTHERS IN MMF UNLESS OTHERWISE SPECIFIED.
 VOLTAGES - MEASURED FROM POINT INDICATED TO CHASSIS WITH A VTVM NO SIGNAL INPUT.
 INPUT VOLTAGE 117V AC ± 10%.
 TUNING RANGE - 535 TO 1620 KC
 IF - 455 KC

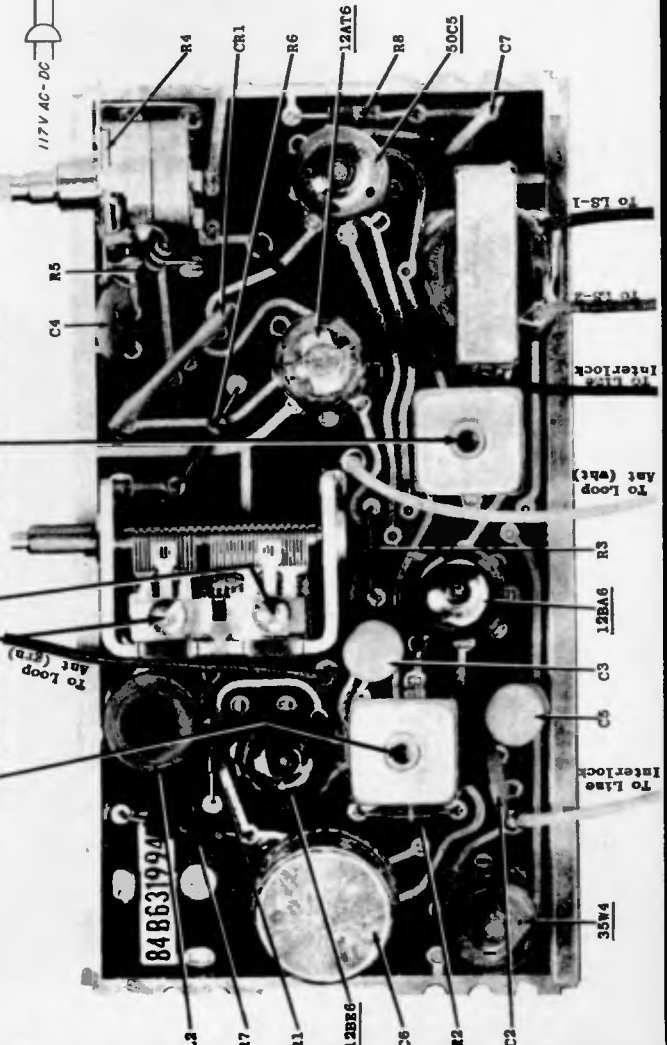
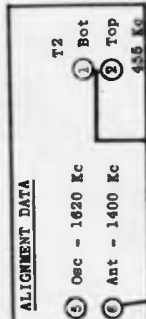
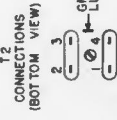
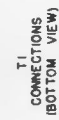

Motorola

MODELS

- 64X1** MAHOGANY
- 64X2** EMERALD GRN

CHASSIS
HS-440

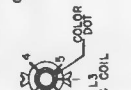
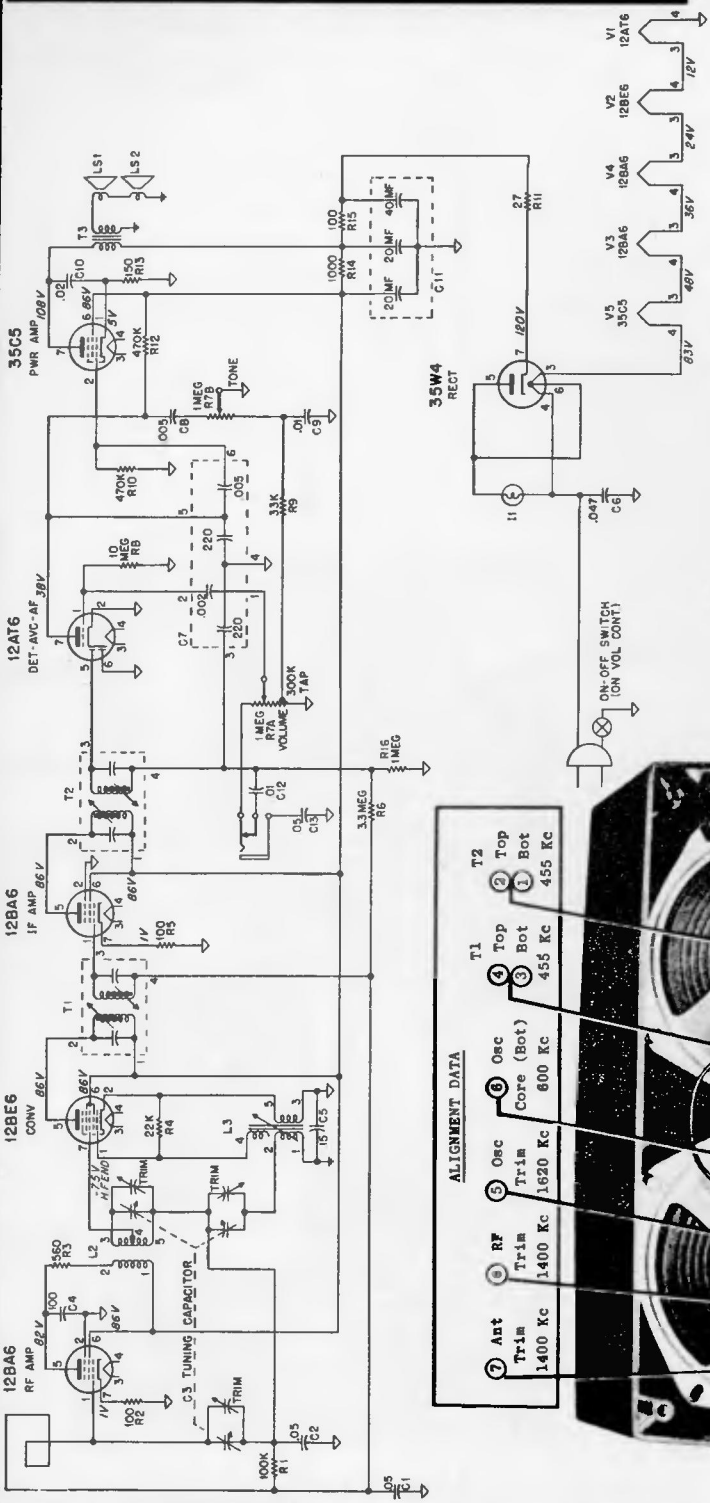

NOTES
 CAPACITORS - DECIMAL VALUES IN MF, ALL OTHERS IN MMF UNLESS OTHERWISE SPECIFIED
 VOLTAGES - MEASURED FROM POINT INDICATED TO INPUT AND SIGNAL INPUT
 TUNING RANGE - 535 TO 1650 KC
 IF - 455 KC
 -B- -B- - CHASSIS GND

ALIGNMENT DATA

7	Ant	Trim	1400 Kc
6	RF	Trim	1400 Kc
5	Osc	Trim	1620 Kc
4	Osc	Core (Bot)	600 Kc
3	Osc	Core (Top)	455 Kc
2	Osc	Core (Bot)	455 Kc
1	Osc	Core (Top)	455 Kc

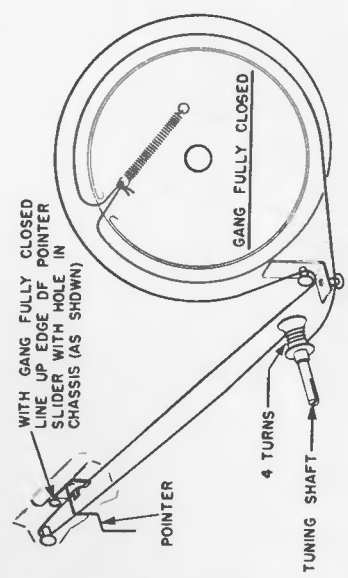
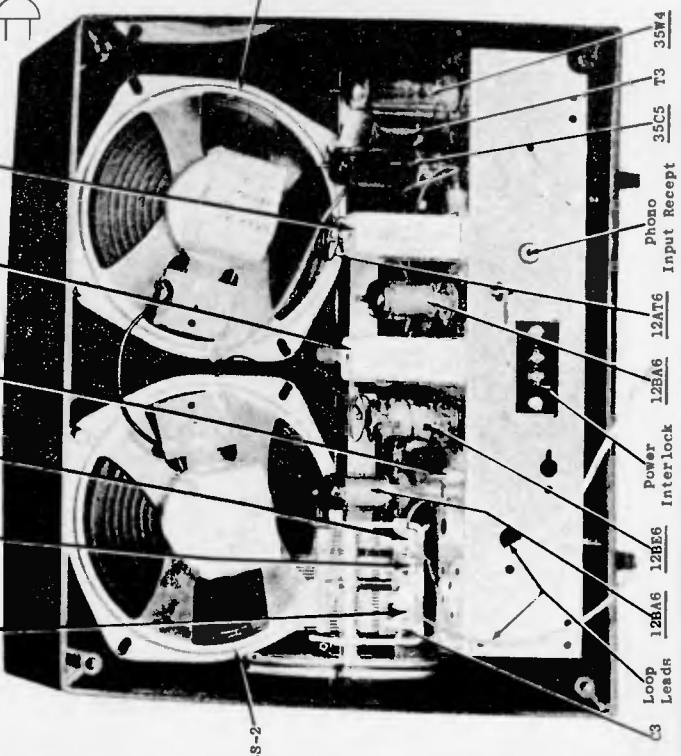

WITH GANG FULLY CLOSED
 LINE UP EDGE OF POINTER
 SLIDER WITH HOLE IN
 CHASSIS (AS SHOWN)

Motorola

MODELS
54HF1
54HF1B
 CHASSIS
HS-443

TO REMOVE CHASSIS FROM CABINET

1. Remove amplifier control knobs.
2. Remove the screws at the corners of the record changer mounting board.
3. Grasp record changer base and tilt up front of mounting board. Disconnect leads from changer.
4. Completely remove record changer and mounting board.
5. Disconnect speaker leads.
6. Remove the screws that mount the amplifier chassis to the cabinet and remove chassis from cabinet.

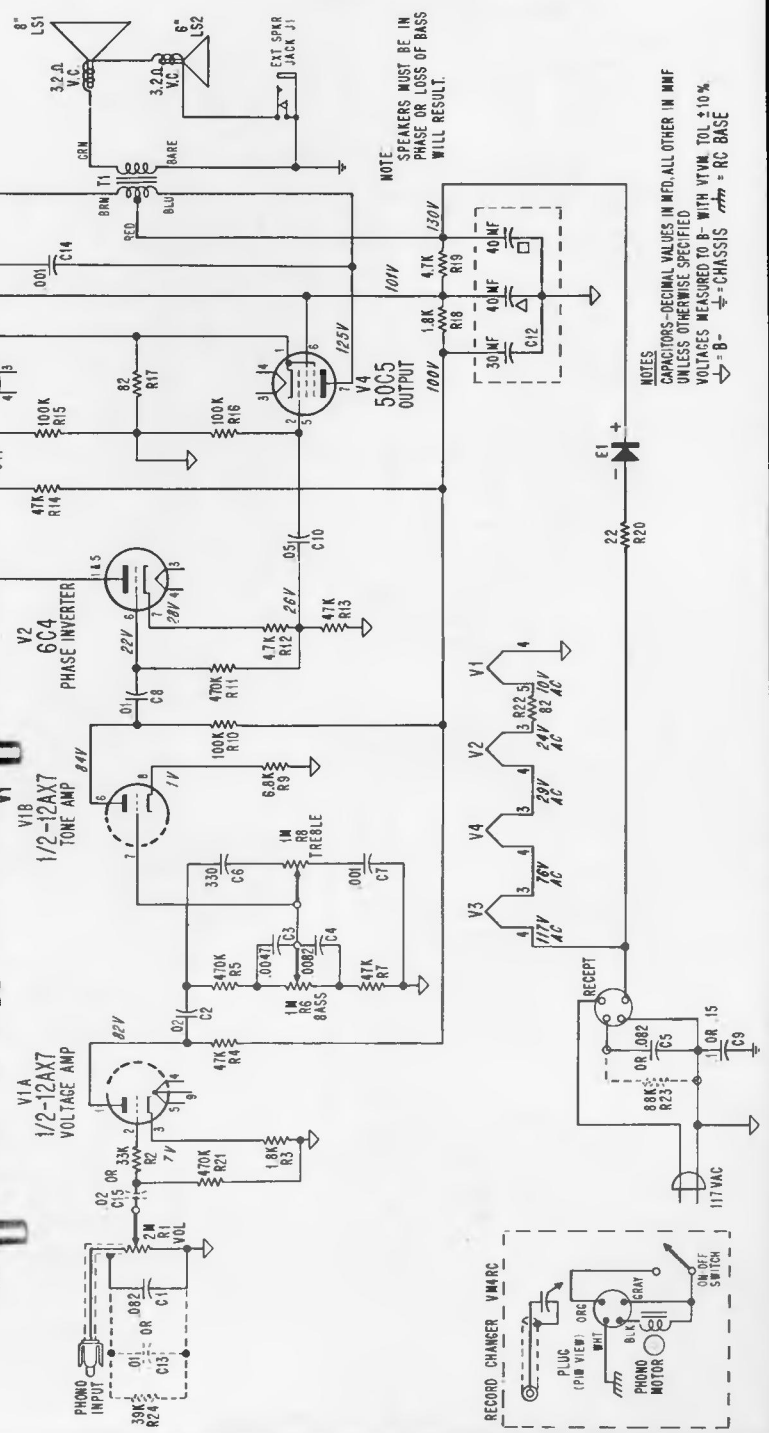
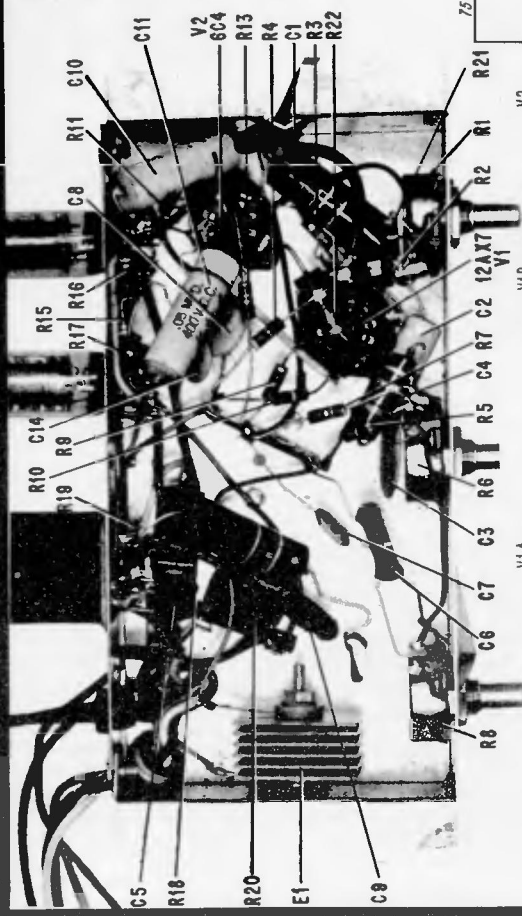

NOTES
 CAPACITORS—DECIMAL VALUES IN MFD. ALL OTHER IN MUF
 UNLESS OTHERWISE SPECIFIED
 VOLTAGES MEASURED TO B— WITH VTVM TOL ±10%
 → = CHASSIS ⚡ = RC BASE

Motorola

Model 34F1, Chassis HS-444

and

Model 34F1C, Chassis HS-467

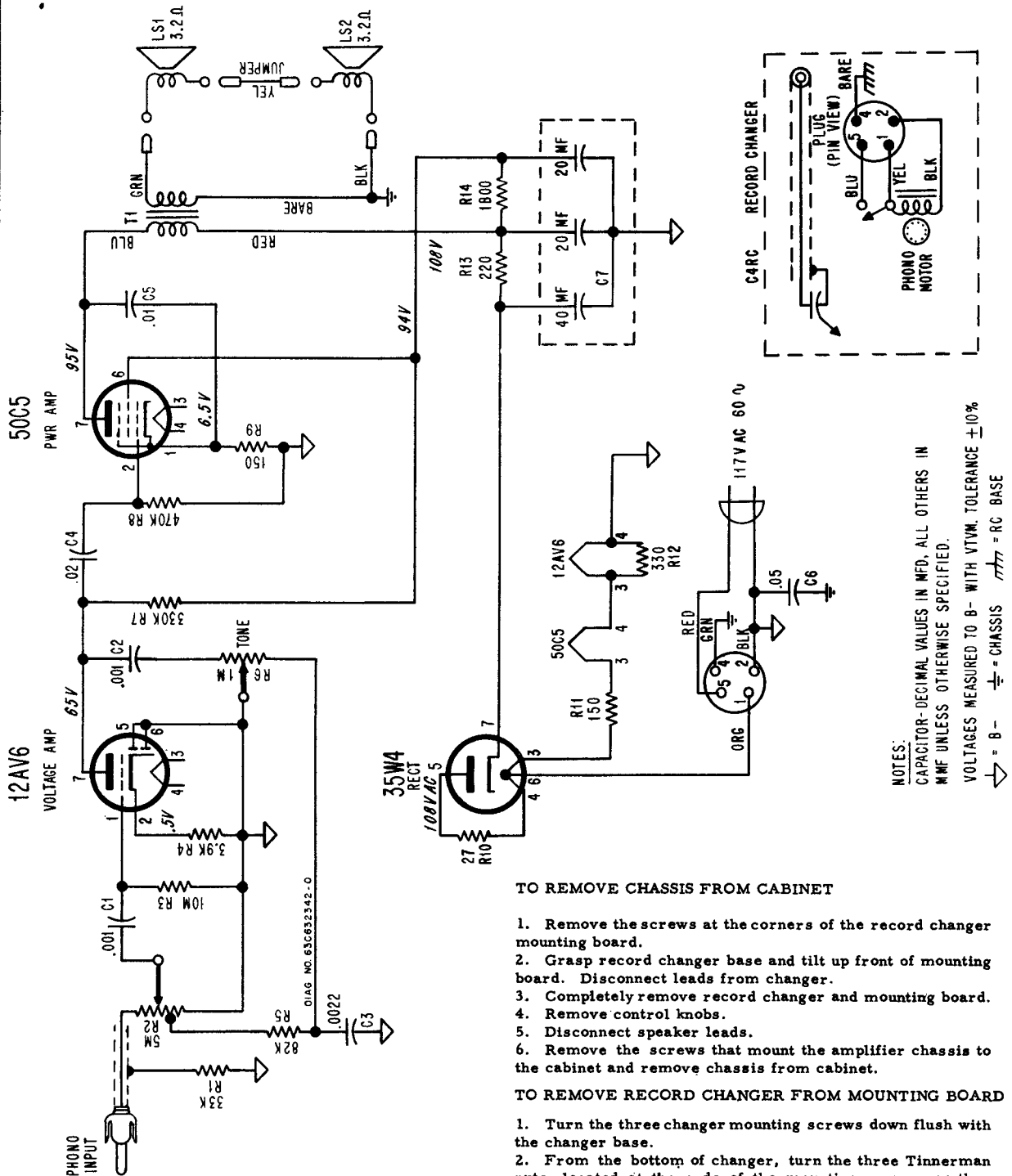

NOTES:
 CAPACITOR-DECIMAL VALUES IN MFD. ALL OTHERS IN MMF UNLESS OTHERWISE SPECIFIED.
 VOLTAGES MEASURED TO B - WITH VTVM. TOLERANCE ±10%
 ▷ = B - ⊕ = CHASSIS ▩ = RC BASE

TO REMOVE CHASSIS FROM CABINET

1. Remove the screws at the corners of the record changer mounting board.
2. Grasp record changer base and tilt up front of mounting board. Disconnect leads from changer.
3. Completely remove record changer and mounting board.
4. Remove control knobs.
5. Disconnect speaker leads.
6. Remove the screws that mount the amplifier chassis to the cabinet and remove chassis from cabinet.

TO REMOVE RECORD CHANGER FROM MOUNTING BOARD

1. Turn the three changer mounting screws down flush with the changer base.
2. From the bottom of changer, turn the three Tinnerman nuts, located at the ends of the mounting screws, so they are parallel with the screws.
3. Grasp record changer by the base and lift up.

MANUAL OF 1955 MOST-OFTEN-NEEDED RADIO DIAGRAMS

MOTOROLA, INC.

MODELS

- 55A1 Mahogany
- 55A2 Ebony
- 55A3 White

CHASSIS

HS-422

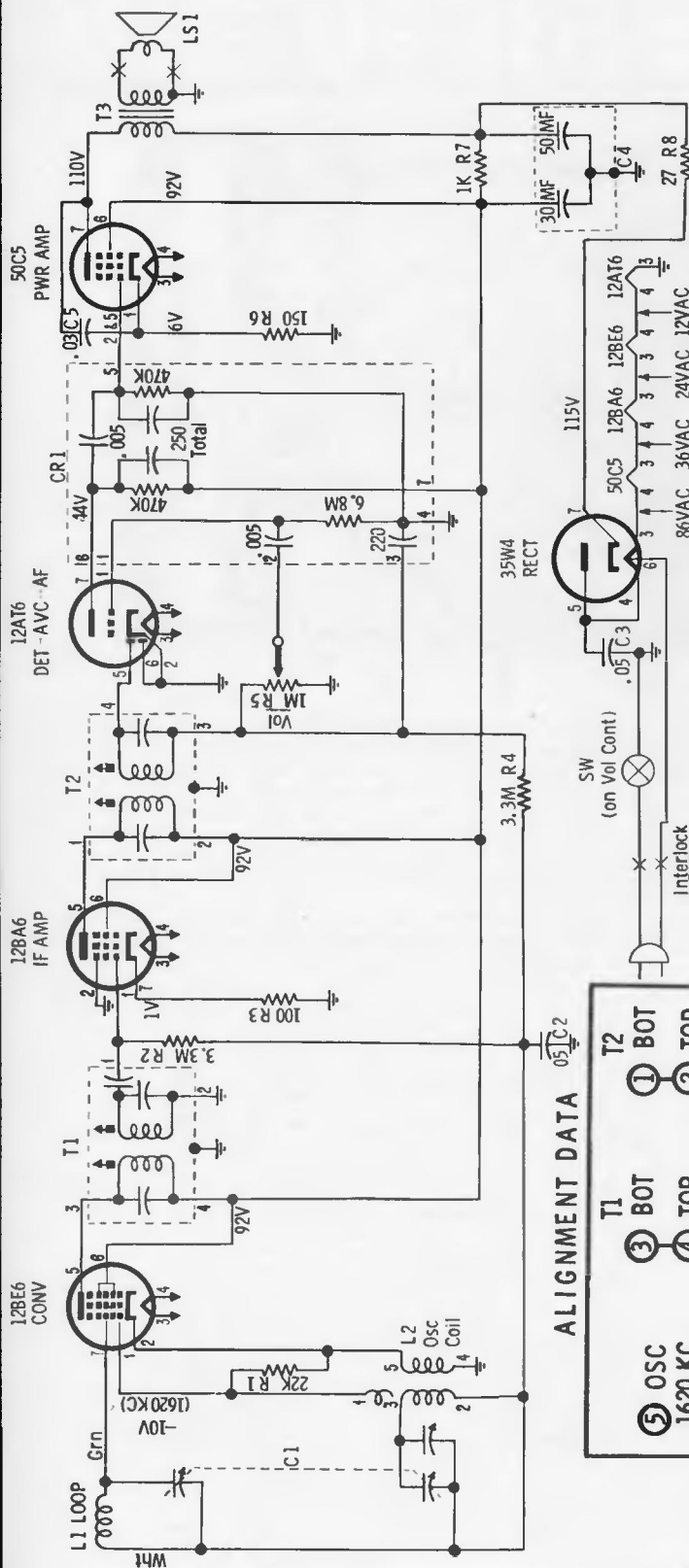

NOTES:
 Capacitors - Decimal values in MF, all others in MMF unless otherwise specified
 Voltages - Measured from point indicated to ground with a VTVM. No signal input
 input voltage - 117V AC $\pm 10\%$.
 Tuning Range - 535 to 1620 KC
 IF - 455 KC

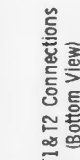

ALIGNMENT DATA

⑤ OSC	1620 KC
③ T1 BOT	④ T1 TOP
① T2 BOT	② T2 TOP
① BOT	② TOP
③ 455 KC	④ 455 KC

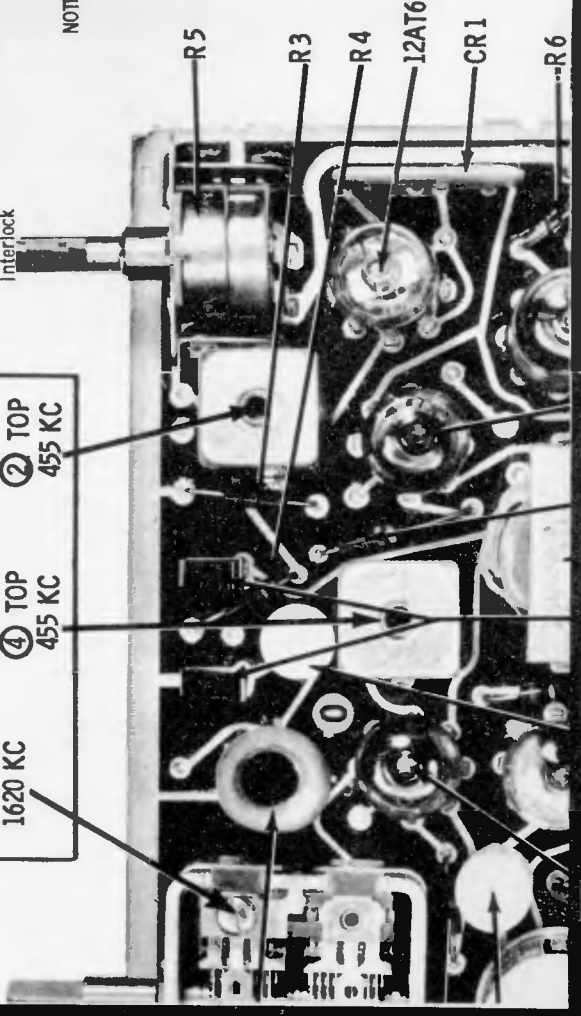

MANUAL OF 1955 MOST-OFTEN-NEEDED RADIO DIAGRAMS

MOTOROLA, INC.

**CHASSIS
HS-456**

ALIGNMENT DATA

5	Osc - Front 1620 Kc	T1 Bot	T2 Bot
6	Ant - Rear 1400 Kc	4 Top 455 Kc	2 Top 455 Kc

MODELS

55C1	MAHOGANY
55C2	WHITE
55C3	MINT GREEN
55C4	CLOVER PINK

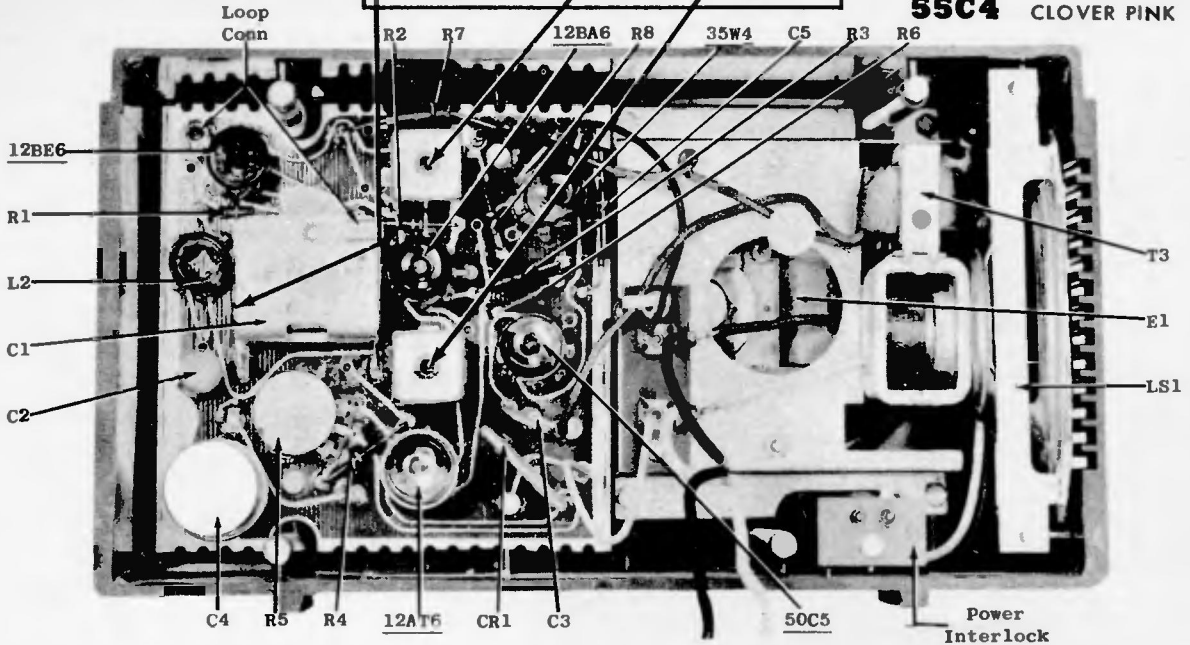

COMPONENT REPLACEMENT

1. To prevent tube breakage, remove them before replacing components.
2. WHEN REMOVING DEFECTIVE COMPONENTS USE ONLY A SMALL SOLDERING IRON (60 WATTS OR LESS) TO AVOID DAMAGE TO THE WIRING. DO NOT USE A SOLDERING GUN. WARNING: THE LEADS ARE VERY THIN, AND EXCESSIVE HEAT WILL BURN THEM OR LOOSEN THEM FROM THE BASE MATERIAL.
3. Plated connections or leads, if damaged, may be replaced with a jumper of regular hookup wire.

4. It is recommended that multiple lug components be removed by immersing all the lugs simultaneously into a controlled temperature soldering pot, Motorola Part Number 66T632703. The component may then be lifted off the chassis easily. If a soldering pot is not available, heat each lug individually with a small soldering iron and shake or brush off as much molten solder as possible. Then, by alternately heating and loosening each lug, the entire component will be freed.
5. An individual tube clip may be removed by squeezing it with pliers and then unsoldering it. The new clip snaps into the hole.

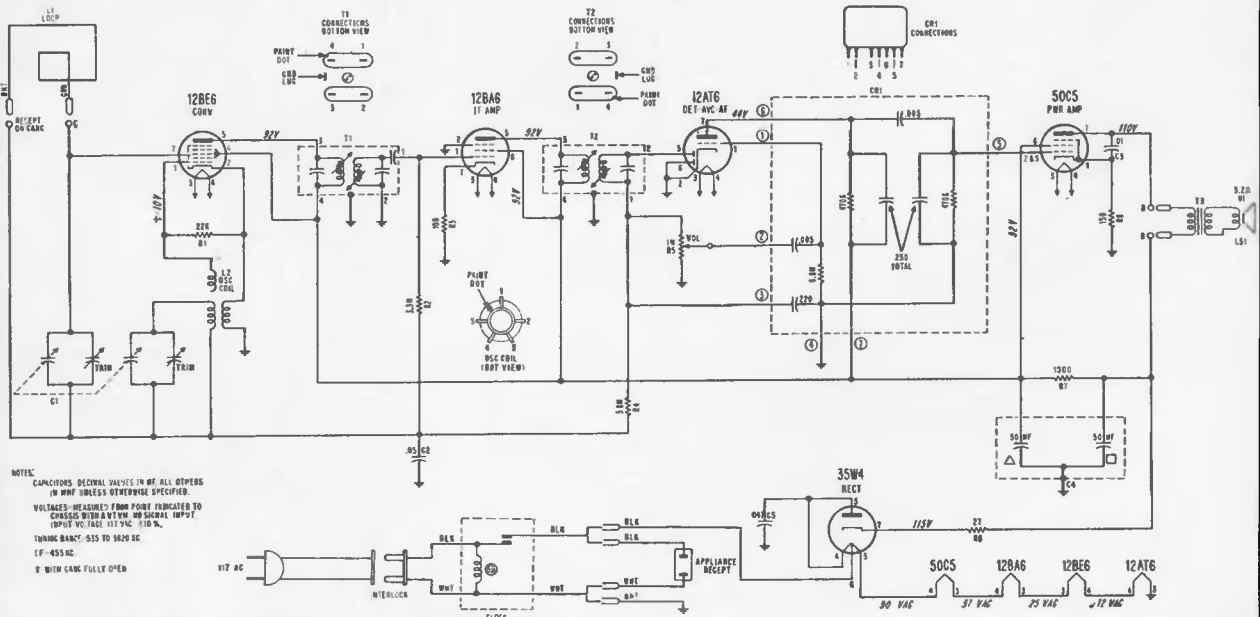

Motorola

(Alignment on the next page, over.)

MODEL
MOTOROLA 5MF
FORD FDH-18805-B2

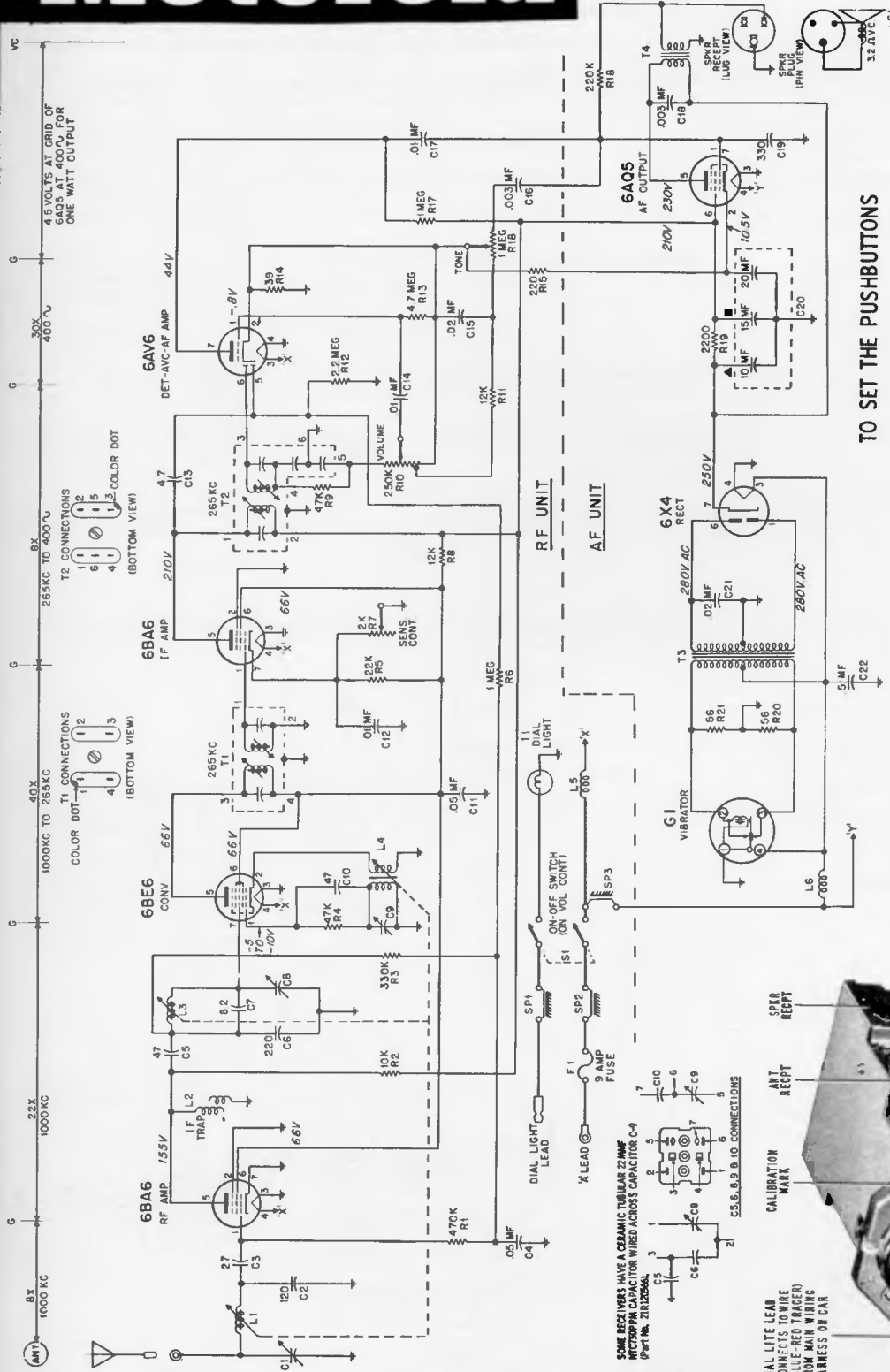

TO SET THE PUSHBUTTONS

- Pushbuttons may be set up in any order; while setting pushbuttons keep antenna in lowest position so that only local stations will be picked up.
1. Turn receiver on and allow it to operate for fifteen minutes.
 2. Unlock pushbuttons by pulling them out.
 3. Accurately tune in a desired station.
 4. Lock one of the pushbuttons to this station by pushing it firmly in.
 5. Repeat steps 3 & 4 until all five pushbuttons are set.

NOTE: ALL RESISTORS INDICATED IN OHMS UNLESS OTHERWISE SPECIFIED. CAPACITORS INDICATED IN MMF UNLESS OTHERWISE SPECIFIED. VOLTAGE READINGS SHOWN WERE MEASURED FROM POINT INDICATED TO CHASSIS WITH A VTVM ZERO SIGNAL INPUT. INPUT VOLTAGE WAS 72V DC, MEASURED AT FUSE RECEPTACLE.

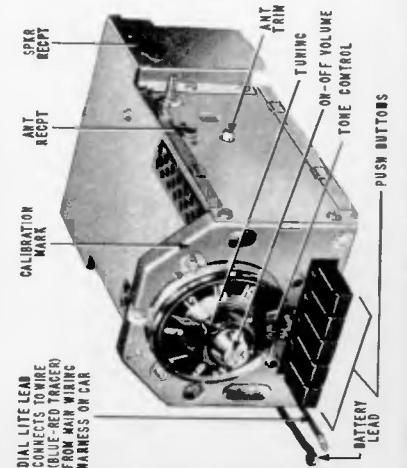

SOME RECEIVERS HAVE A CERAMIC TUBULAR 25MF MICROFARAD CAPACITOR WIRED ACROSS CAPACITOR C-4 (Part No. 21R22566A)

MANUAL OF 1955 MOST-OFTEN-NEEDED RADIO DIAGRAMS

MOTOROLA Alignment for Ford Models 5MF and 5MF8 (Continued)

ALIGNMENT

Connect output meter across speaker voice coil. Set tone control to high & volume to maximum. Attenuate generator to maintain 1.79 volts (1 watt) on output meter to prevent overloading receiver. *Field alignment of tuner is not recommended unless it has been tampered with or has had components replaced.

STEP	DUMMY ANTENNA	GENERATOR CONNECTION	GENERATOR FREQUENCY	TUNER SET TO	ADJUST. (in order shown)	REMARKS
IF ALIGNMENT						
1.	.1 mf	Pin 7 -6BE6	265 Kc	Hi end stop	1, 2, 3 & 4	Peak for maximum.
*RF ALIGNMENT - Note: For step 2 back tuner cores 1-3/8" out of coils to eliminate their effect on trimmer adjustments.						
2.	See Fig.	Ant. recept	1605 Kc	Hi end stop	5, 6 & 7	Peak for maximum.
3.	See Fig.	Ant. recept	1200 Kc	9/32" from hi end stop	8, 9 & 10	Peak for maximum using core alignment tools shown in Figure.
4.	See Fig.	Ant. recept	1605 Kc	Hi end stop	5, 6 & 7	Peak for maximum.
5.	Repeat steps 3 & 4 until no further increase; then cement cores in place.					
SENSITIVITY CONTROL						
6.	See Fig.	Ant. recept	600 Kc & 5 microvolts output	Tune for max	Sensitivity control	Adj for 1.79 volt output (1 watt)
ANTENNA TRIMMER ADJ						
7.	-	-	-	Weak station around 1400 Kc	7	With receiver in car peak ant trim for max volume. Ant should be fully extended.

TO CALIBRATE POINTER

- Remove dial scale and tune receiver to 1400 Kc signal.
- To rotate pointer pull pointer off shaft, set to coincide with calibration mark on front housing (see cover photo) and push back onto shaft. **CAUTION:** Do not twist pointer while on shaft; this may result in a broken pointer or dial cord.

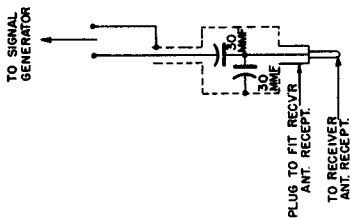

DUMMY ANTENNA DETAIL

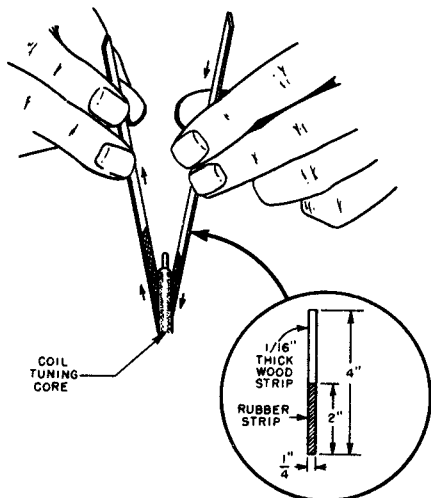

CORE ALIGNMENT TOOL DETAIL

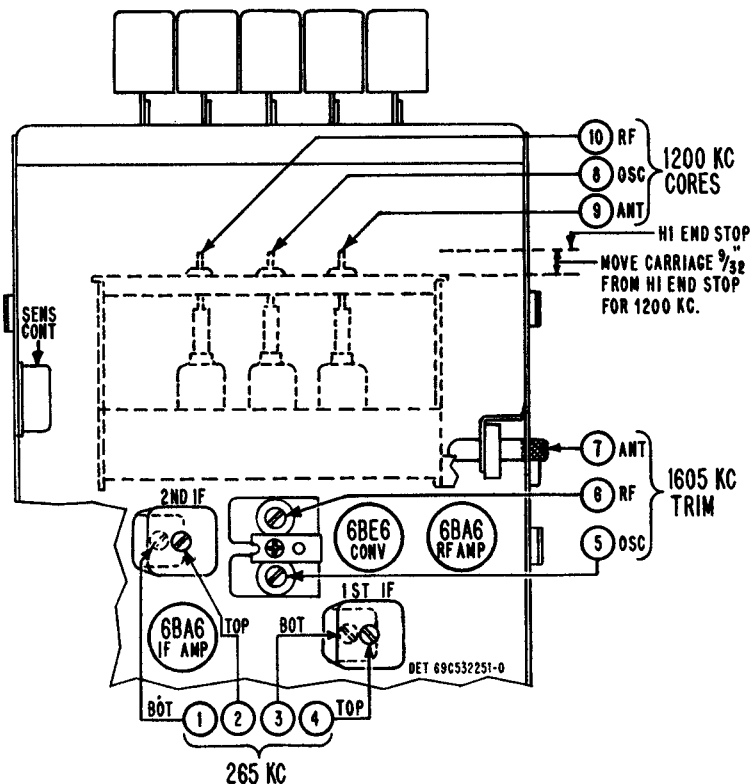

ALIGNMENT ADJUSTMENT LOCATIONS DETAIL

Motorola

MODELS
395
395-12

(Alignment on adjacent page at right)

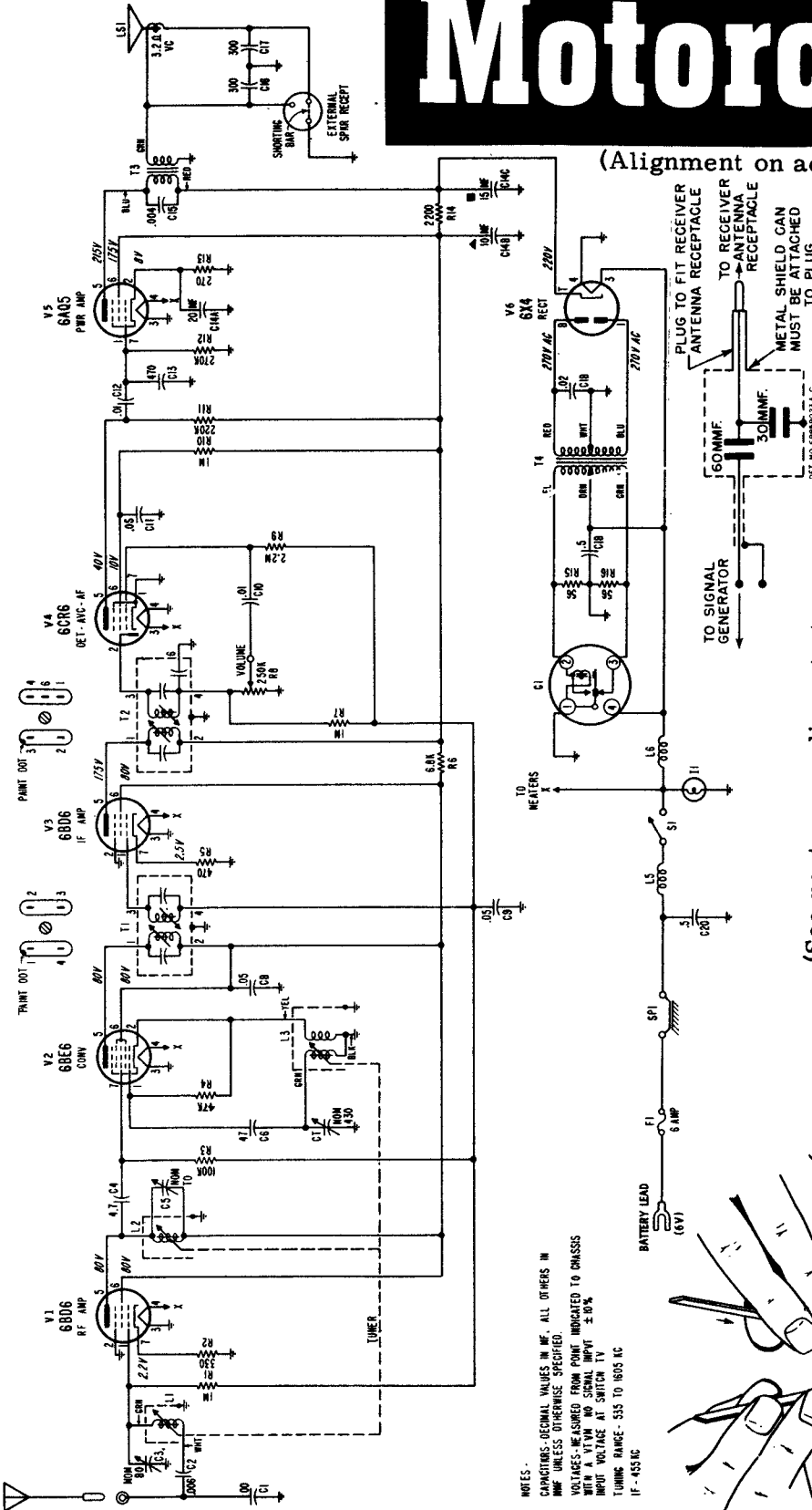

NOTES -
CAPACITORS-DECIMAL VALUES IN MF. ALL OTHERS IN MMF UNLESS OTHERWISE SPECIFIED.
VOLTAGES MEASURED FROM POINT INDICATED TO CHASSIS WITH A VITON NO SIGNAL INPUT $\pm 10\%$
INPUT VOLTAGE AT SWITCH TV
TUNING RANGE- 535 TO 865 KC
IF- 455 KC

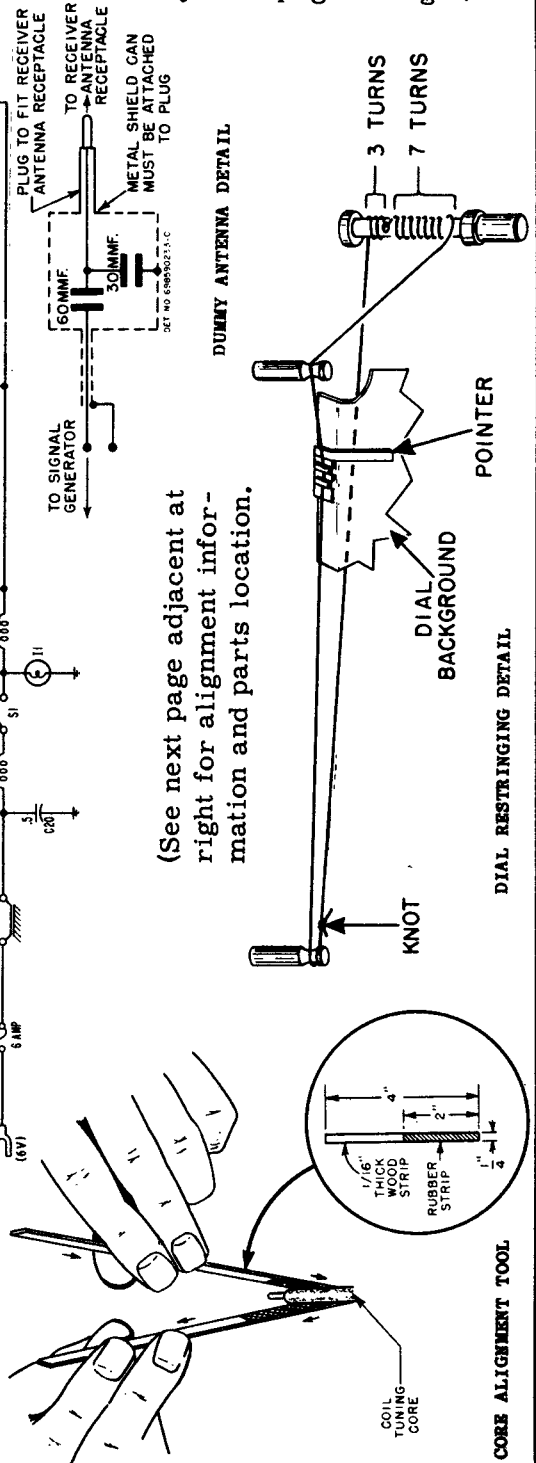

(See next page adjacent at right for alignment information and parts location.)

MANUAL OF 1955 MOST-OFTEN-NEEDED RADIO DIAGRAMS

MOTOROLA Model 395, 395-12, Alignment Adjustments and Parts Location

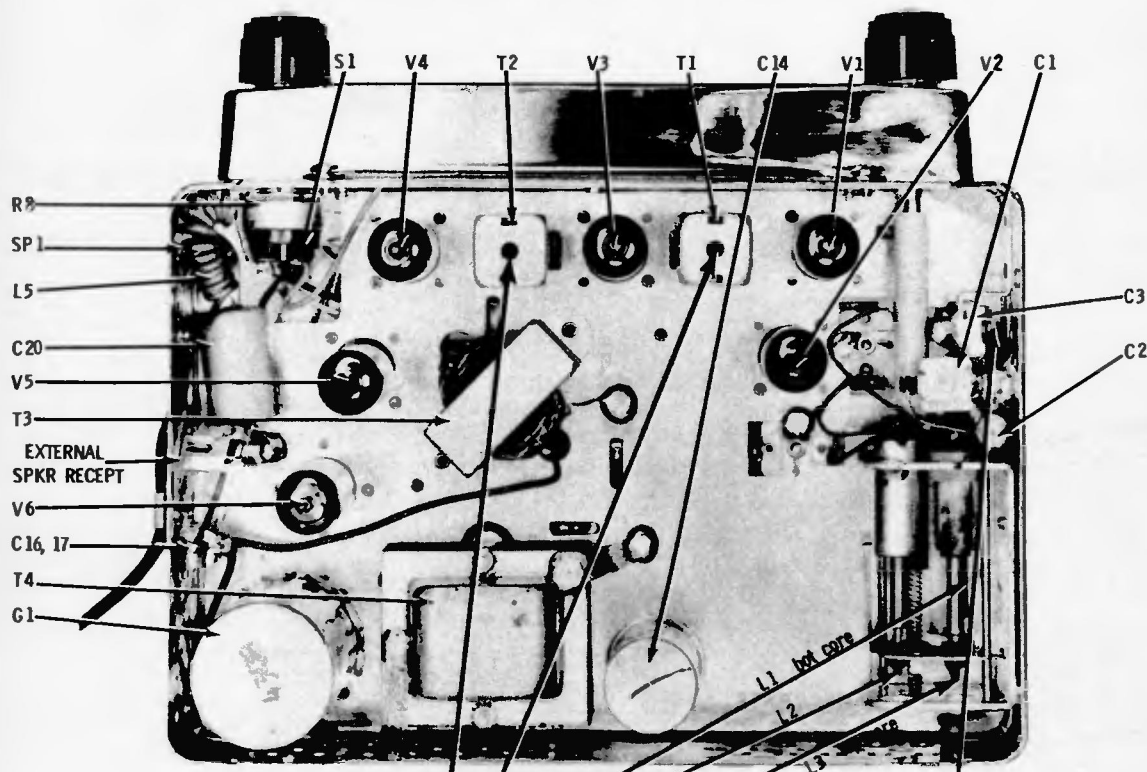

TUBES		
REF. NO.	MODEL 395	MODEL 395-12
V1	6BD6 (RF)	12BD6 (RF)
V2	6BE6	12BE6
V3	6BD6 (IF)	12BD6 (IF)
V4	6CR6	12CR6
V5	6AQ5	12AQ5
V6	6X4	12X4

④ TOP 1st IF	⑧ OSC CORE 1400 KC	ANT TRIM ⑦
③ BOT 455 KC	⑨ RF CORE 1400 KC	RF TRIM ⑥
② TOP 2nd IF	⑩ ANT CORE 1400 KC	OSC TRIM ⑤
① BOT 455 KC		

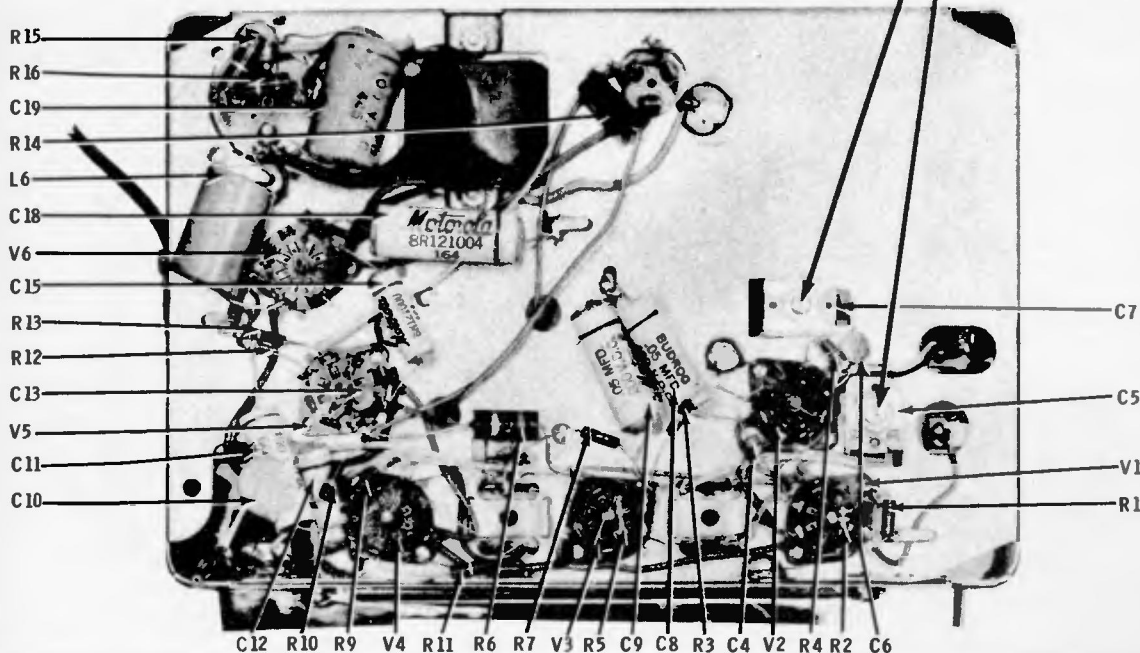

MANUAL OF 1955 MOST-OFTEN-NEEDED RADIO DIAGRAMS

MOTOROLA Models MoPar 613 used in Plymouth P26, P27,
and MoPar 614 used in Dodge D55, D56.

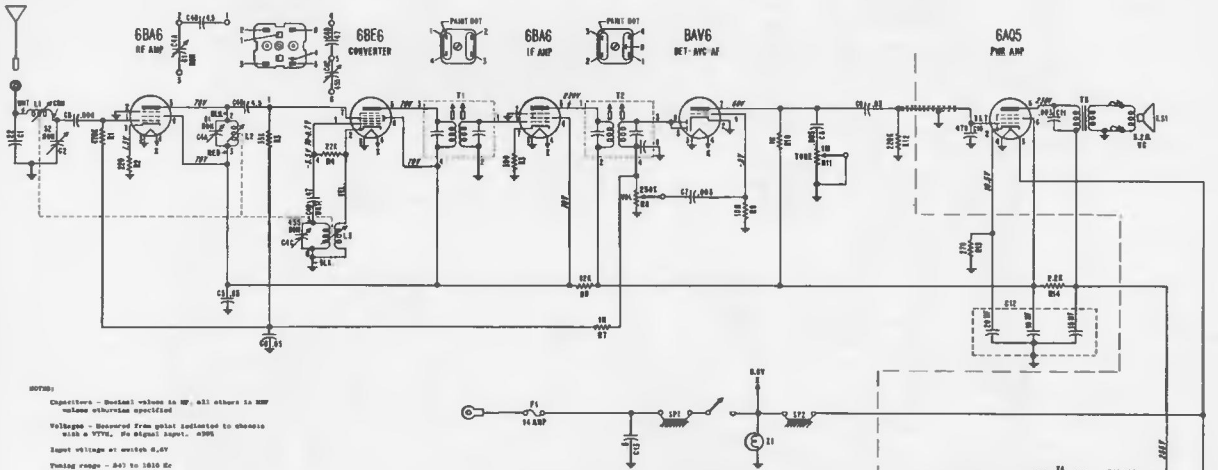

Capacitors - Mica unless shown as MP - all others in MP unless otherwise specified.
Voltage - Derived from a.c. isolated to chassis with a 97V. No signal input. 400V
Input voltage at switch 0.4V
Tuning range - 447 to 1610 Kc
17 - 610 Kc

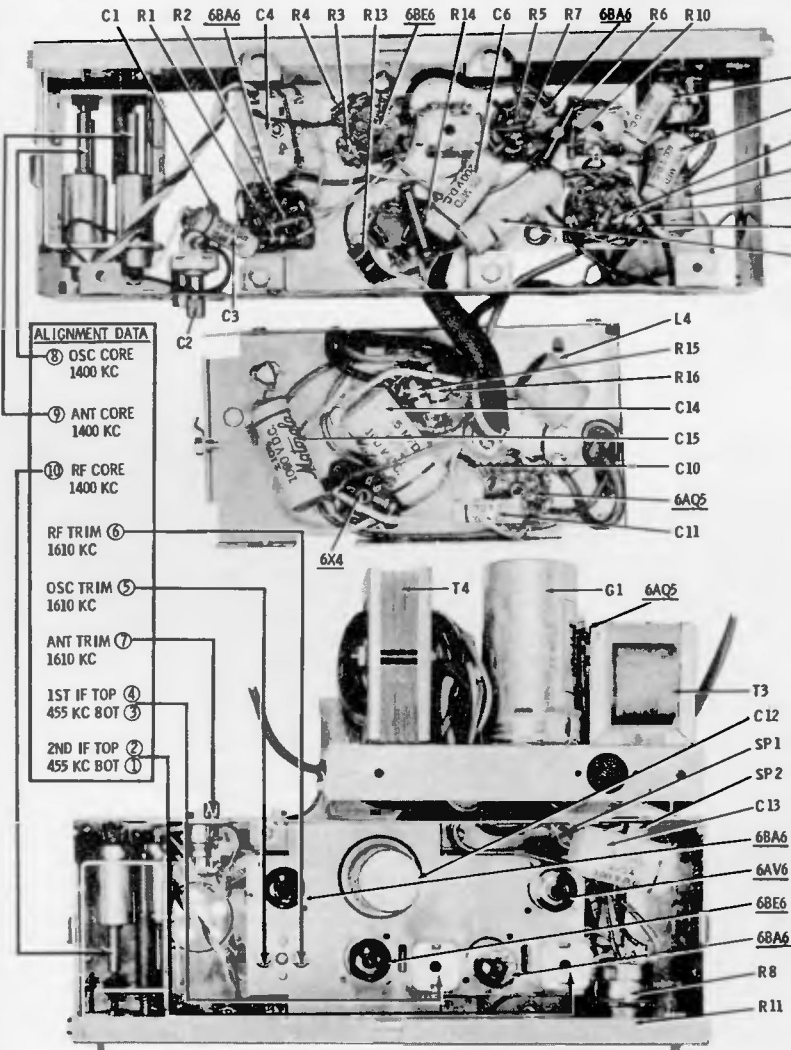

- ALIGNMENT DATA**
- ⑧ OSC CORE 1400 KC
 - ⑨ ANT CORE 1400 KC
 - ⑩ RF CORE 1400 KC
 - RF TRIM ⑥ 1610 KC
 - OSC TRIM ⑤ 1610 KC
 - ANT TRIM ⑦ 1610 KC
 - 1ST IF TOP ④ 455 KC BOT ③
 - 2ND IF TOP ② 455 KC BOT ①

ALIGNMENT ADJUSTMENT & PARTS LOCATION



DUMMY ANTENNA DETAIL

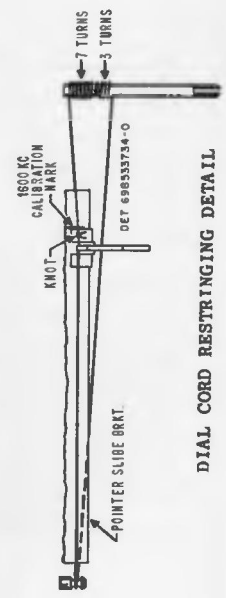

DIAL CORD RESTRINGING DETAIL

MANUAL OF 1955 MOST-OFTEN-NEEDED RADIO DIAGRAMS

MOTOROLA Models MoPar 833, MoPar 834, and MoPar 836

(For Alignment see next page, over.)

GENERAL INFORMATION

Automotive type receivers designed for installation in the following cars:

Model 833 - Dodge D55, D56
 Model 834 - DeSoto S21, S22
 Model 836 - Plymouth P26, P27

RANGE - 540 to 1600 Kc IF - 262 Kc

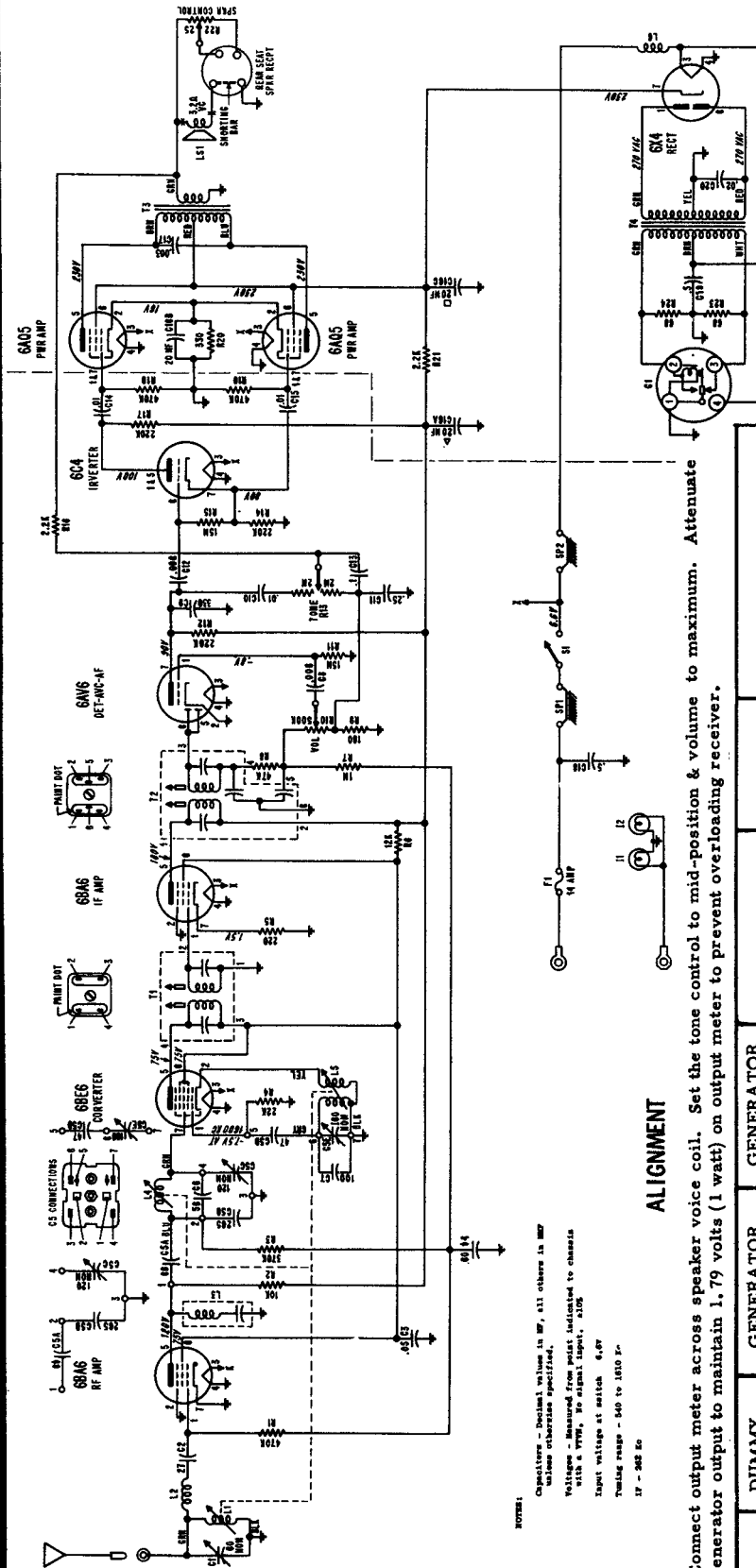

NOTES:
 Capacitors - Decimal values in MF, all others in MUF unless otherwise specified.
 Voltages - Measured from point indicated to chassis with a VTVM, 50 signal input, 400K.
 Input voltage at switch 6.4V.
 Tuning range - 540 to 1610 Kc.
 IF - 262 Kc

ALIGNMENT

Connect output meter across speaker voice coil. Set the tone control to mid-position & volume to maximum. Attenuate generator output to maintain 1.79 volts (1 watt) on output meter to prevent overloading receiver.

STEP	DUMMY ANTENNA	GENERATOR CONNECTION	GENERATOR FREQUENCY	TUNER SET TO	ADJUST	REMARKS
1.	IF ALIGNMENT .1 mf	6BE6 grid (pin 7) & chassis	262 Kc	Hi end stop	1, 2, 3, 4	Peak for maximum.
RF ALIGNMENT	Note: Back tuner cores completely out of coils before proceeding. Remove escutcheon to expose core screws.					
2.	See Fig.	Ant recept	1615 Kc	Hi end stop	5, 6, 7	Peak for maximum.
3.	See Fig.	Ant recept	1000 Kc	25/32" from hi end stop	8, 9, 10	Peak for maximum. Use alignment tool, Part No. 66A76278.
4.	Repeat steps 2 and 3 until no further increase, then cement cores in place.					
5.	-	-	-	Weak station around 1400 Kc	7	With radio installed in car, peak ant trimmer.

POINTER CALIBRATION

Tune receiver to a 1000 Kc signal and adjust pointer adjusting cam located at the front portion of the core carriage until pointer lines up with calibration mark on dial background.

MANUAL OF 1955 MOST-OFTEN-NEEDED RADIO DIAGRAMS

MOTOROLA Alignment Information for MoPar
Models 833, 834, 836, (Continued)

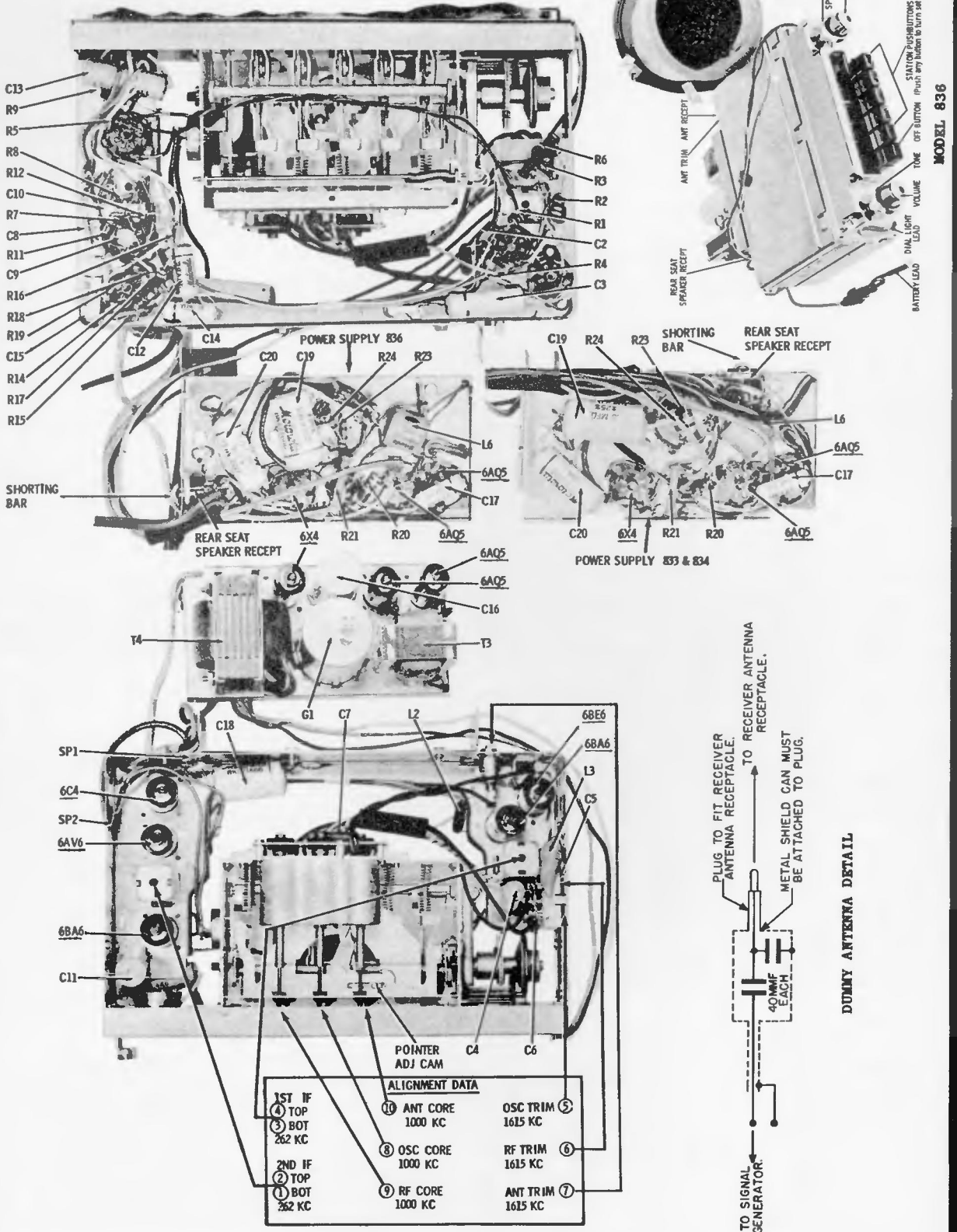

ALIGNMENT ADJUSTMENTS & PARTS LOCATION

MANUAL OF 1955 MOST-OFTEN-NEEDED RADIO DIAGRAMS

Motorola

MODELS
MoPar 900
MoPar 901

(For Alignment see the next page, over.)

900 for Dodge D55, D56
901 for DeSoto S21, S22

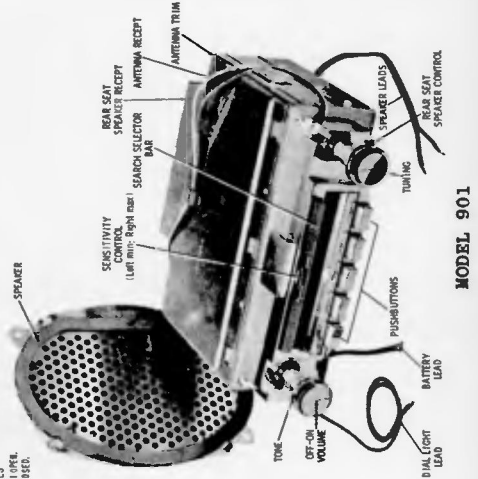
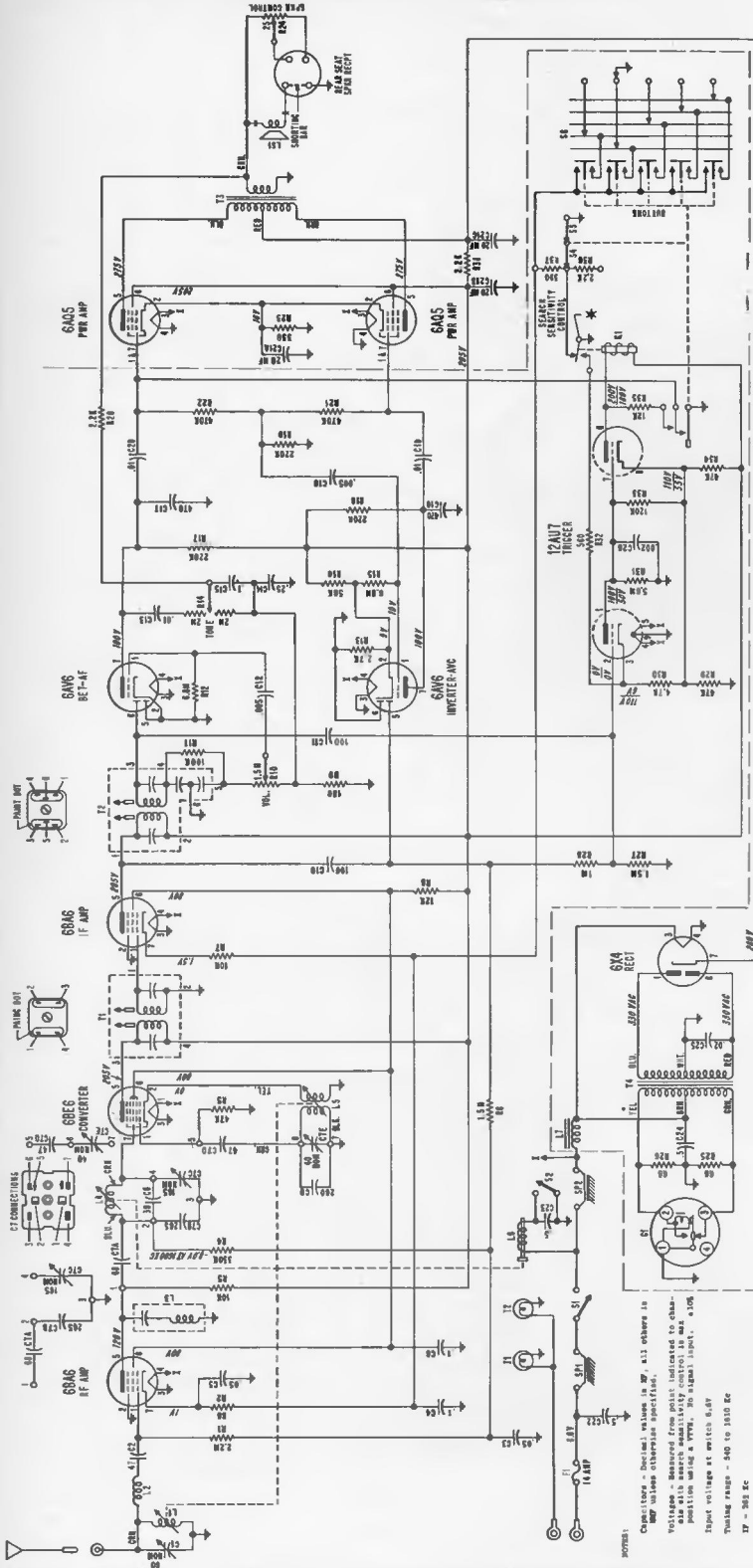

MODEL 901

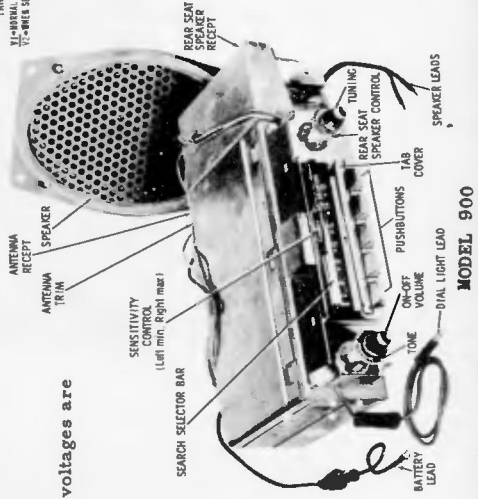

MODEL 900

RESISTOR DIFFERENCE
In some sets, the following resistors and voltages are used in place of those shown on schematic:

Resistors	6R5581	3300	10%	1/2W
R-13	6R5581	3300	10%	1/2W
R-30	6R490492	6800	20%	1W
R-31	6R3988	3.3 meg	20%	1/2W
R-32	6R6229	1000	10%	1/2W

Voltages	6AV6 Inverter	pin 2	12 volts
6AV6 Inverter	pin 2	12 volts	
12AU7 Trigger	pin 1 & 7	100V	55V
pin 3	110V	7V	
pin 8	100V	60V	

MANUAL OF 1955 MOST-OFTEN-NEEDED RADIO DIAGRAMS

MOTOROLA MoPar 900 and 901 Models, Alignment Information (Continued)

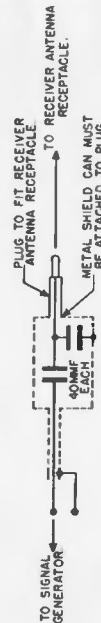
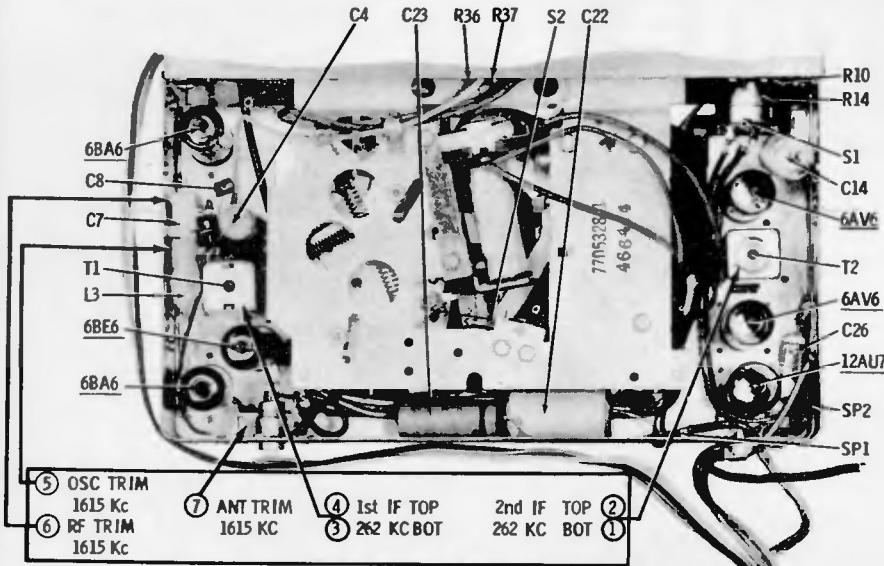

DUMMY ANTENNA DETAIL

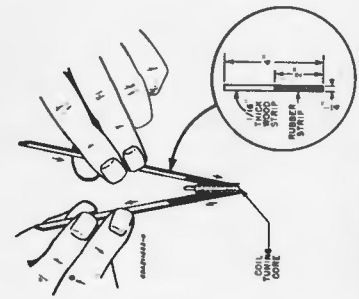
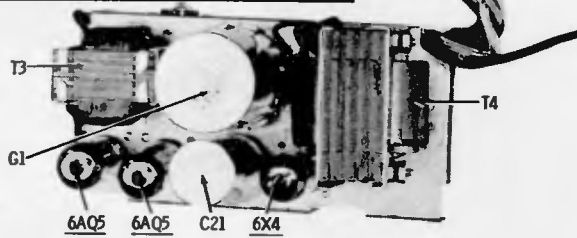

CORE ALIGNMENT TOOL DETAIL

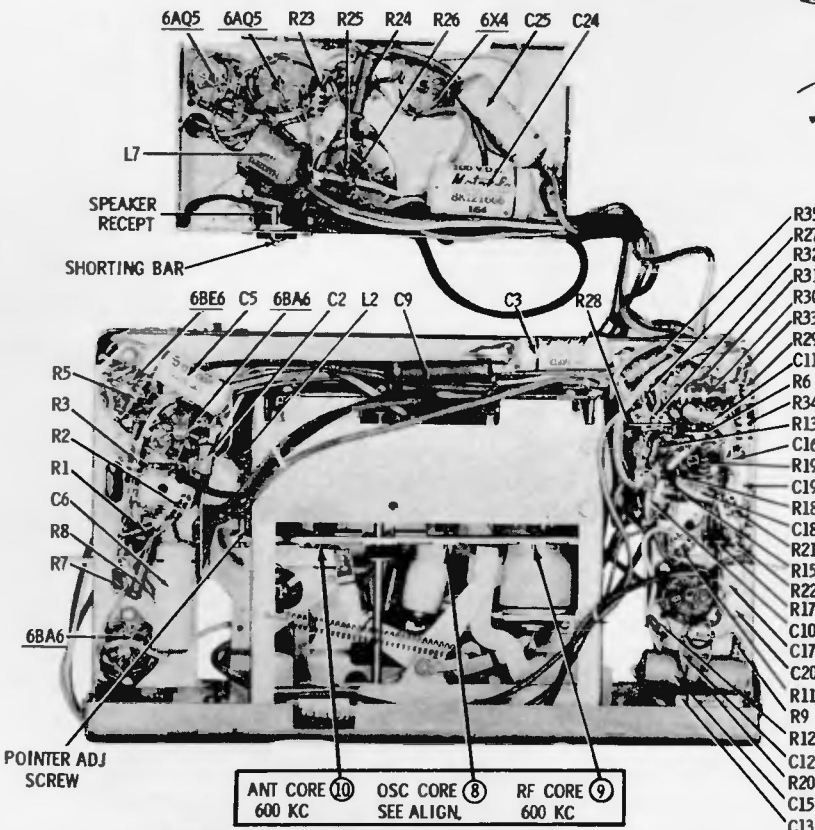

ALIGNMENT ADJUSTMENTS & PARTS LOCATIONS.

TO SET PUSHBUTTONS

1. Turn receiver on and allow to operate for fifteen minutes. Antenna should be fully extended.
2. Open the hinged tab cover below the dial scale, exposing the five red pushbutton setting tabs.
3. Starting at left end of dial, tune in manually first desired station and move the first pushbutton setting tab until it lines up with the dial pointer tip.
4. Repeat step 3 for the remaining pushbutton setting tabs.
5. Check the settings of each pushbutton setting tab by depressing the corresponding station selector button. If the station is not tuned in exactly, readjust the tab.
6. Pushbutton setting should be done in sequence from left to right, using the pushbutton setting tabs in the same sequence.

MANUAL OF 1955 MOST-OFTEN-NEEDED RADIO DIAGRAMS

OLYMPIC RADIO MODEL 401

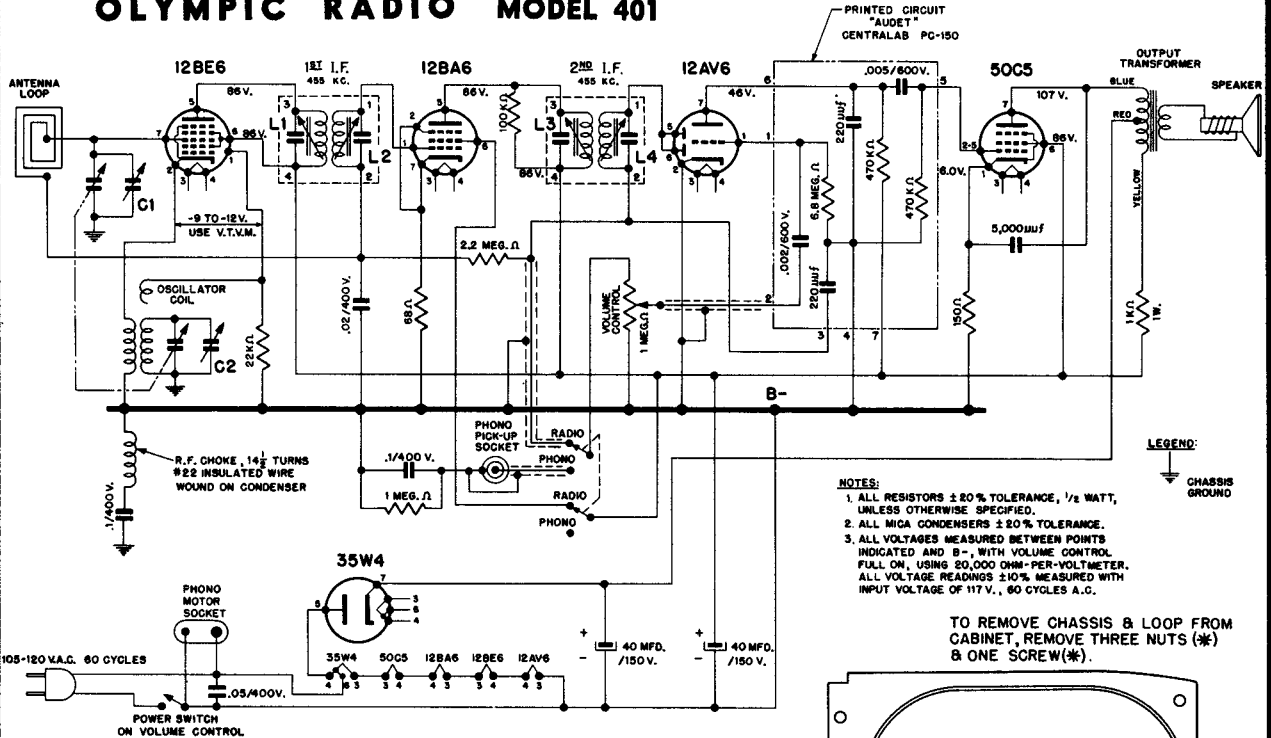

TO REMOVE CHASSIS & LOOP FROM CABINET, REMOVE THREE NUTS (*) & ONE SCREW(*).

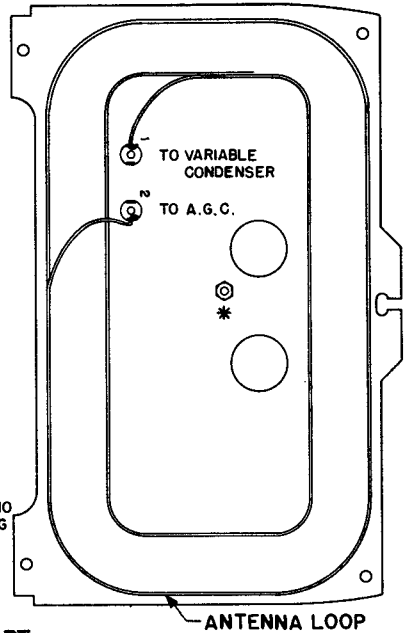
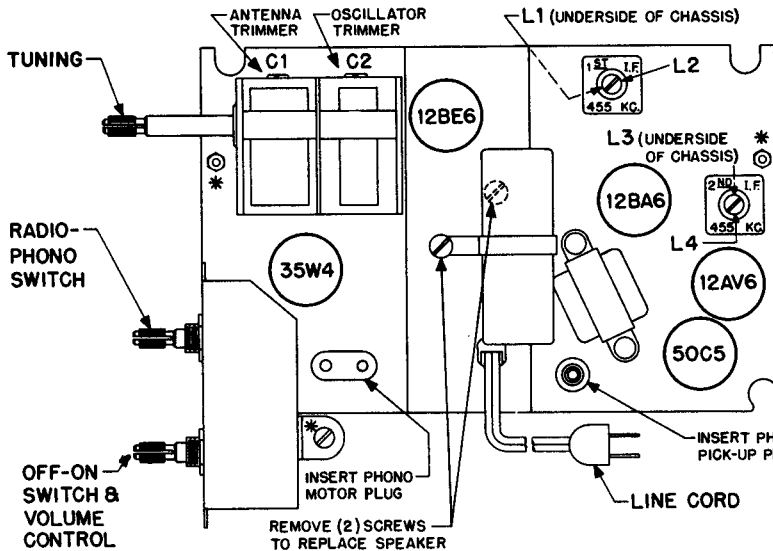

ALIGNMENT PROCEDURE CHART

STEP	CONNECT HIGH SIDE OF SIGNAL GENERATOR TO-	SET SIGNAL GENERATOR TO-	TURN RECEIVER DIAL TO-	ADJUST THE FOLLOWING FOR MAXIMUM OUTPUT (KEEP SIGNAL FROM SIGNAL GENERATOR AS LOW AS POSSIBLE.)
1	ANTENNA SECTION TUNING CONDENSER IN SERIES WITH .1 MFD. COND.	455 KC.	FULL COUNTER-CLOCKWISE POSITION. (CONDENSER PLATES FULLY OPEN)	L4, L3, L2, L1 AND REPEAT IN SAME ORDER (1ST. AND 2ND. I.F. TRANSFORMERS)
2	USE RADIATED SIGNAL	1620 KC.		C2 (OSCILLATOR TRIMMER)
3		1500 KC.	MAXIMUM SIGNAL APPROX. 1500 KC.	C1 (ANTENNA TRIMMER)
4		REPEAT STEPS 2 AND 3		

MANUAL OF 1955 MOST-OFTEN-NEEDED RADIO DIAGRAMS

OLYMPIC RADIO & TELEVISION INC.

OLYMPIC RADIO
MODEL 441

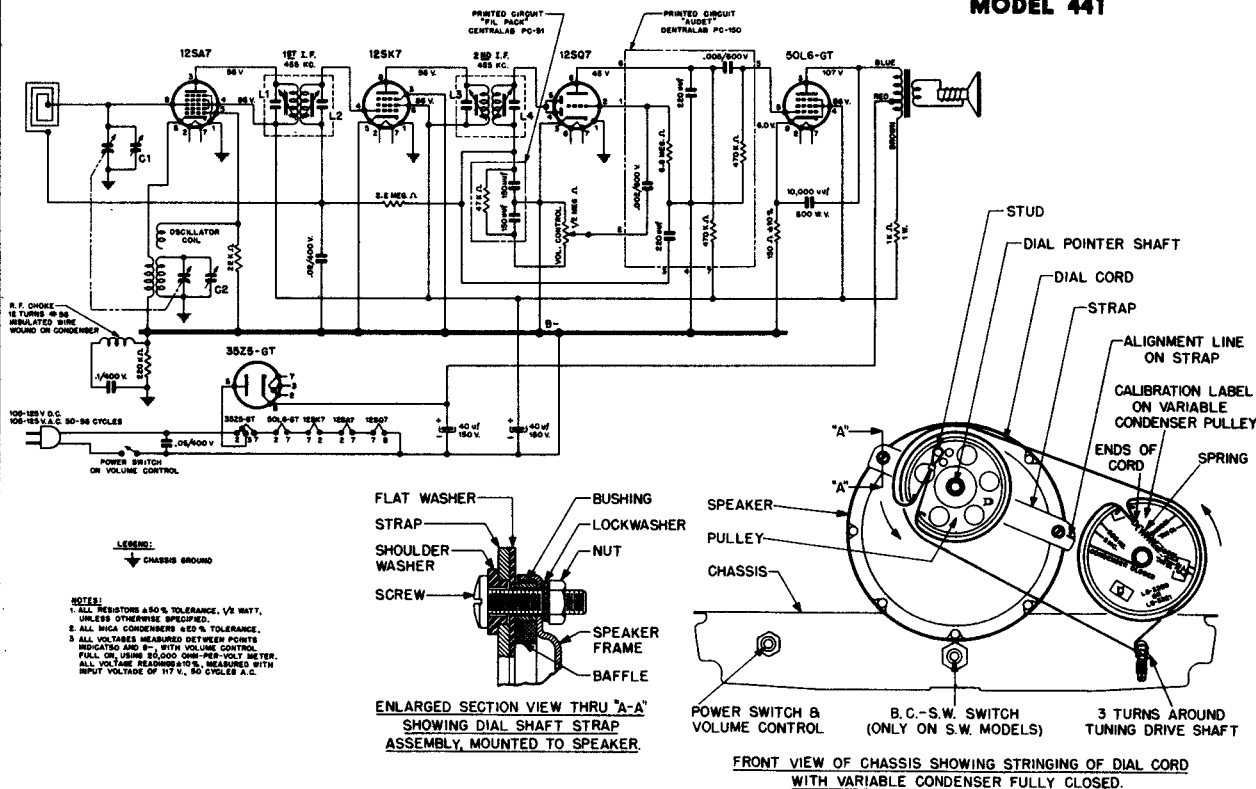

ALIGNMENT INSTRUCTIONS:

The chassis must be removed from the cabinet before alignment can be performed. Before removing chassis pull off dial pointer and the two knobs at the front of the cabinet. At the rear of the cabinet, remove the two screws at the lower right and left hand corners of the chassis apron; these screws are accessible through the notched corners of the antenna loop back. Also remove the screws holding the upper right and left hand corners of the antenna loop back to the cabinet. The chassis can then be easily removed.

Equipment required: Modulated RF signal generator; output meter; insulated screw-driver. two .1 mfd 400 volt condensers.

To insure proper alignment, a radiated signal will be required during part of the alignment procedure. To radiate a signal, connect a loop of about 6 inches in diameter (one turn of #14 or #12 wire) across the output of the signal generator, and place this loop parallel to the loop of the receiver to be aligned, at a distance of about 10 or 12 inches.

A calibration chart is provided on the variable condenser pulley for convenience in setting the variable condenser to the alignment frequencies. These markings are referenced against the line stamped on the dial pulley mounting strap.

Connect the output meter and signal generator as follows:

Output meter: Connect across the speaker voice coil and turn the volume control to maximum (extreme clockwise position).

Signal generator: When the generator is not used to radiate a signal, connect the low side to the receiver chassis through a .1 mfd condenser, clip the high side to the point at which signal injection is required, and keep the output as low as possible. Proceed in the sequence shown in the alignment chart.

When the alignment process is completed, turn the tuning knob shaft until the tuning condenser plates are fully meshed. Replace the chassis inside the cabinet, insert and tighten the screws previously removed, and assemble the two knobs on their shafts at the front panel. With the condenser plate fully meshed place the dial pointer on its shaft so that it points directly to the horizontal line at the "55" end of the dial.

ALIGNMENT PROCEDURE CHART

STEP	CONNECT HIGH SIDE OF SIGNAL GENERATOR TO-	SET SIGNAL GENERATOR TO-	TURN RECEIVER DIAL TO-	ADJUST THE FOLLOWING FOR MAXIMUM OUTPUT. (KEEP SIGNAL FROM SIGNAL GENERATOR AS LOW AS POSSIBLE.)
1	ANTENNA SECTION	455 KC.	FULL CLOCKWISE POSITION. (CONDENSER PLATES FULLY OPEN)	L4, L3, L2, L1 AND REPEAT IN SAME ORDER (1st AND 2nd I.F. TRANSFORMERS)
2	USE RADIATED SIGNAL	500 KC.	1500 KC. ON CALIBRATION LABEL (150 ON DIAL)	C2 (OSCILLATOR TRIMMER)
3		500 KC.	MAXIMUM SIGNAL APPROX. 1500 ON CALIBRATION LABEL (150 ON DIAL)	C1 (ANTENNA TRIMMER)
4	REPEAT STEPS 2 AND 3			

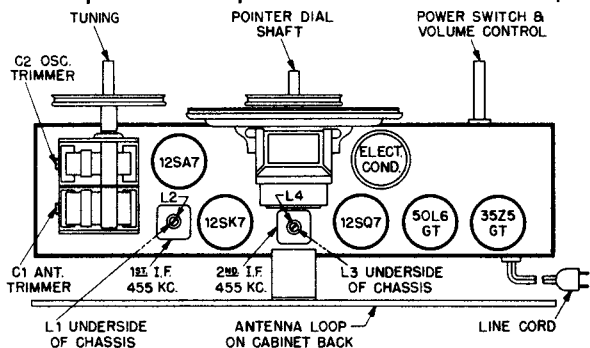

MANUAL OF 1955 MOST-OFTEN-NEEDED RADIO DIAGRAMS

OLYMPIC RADIO MODEL 442

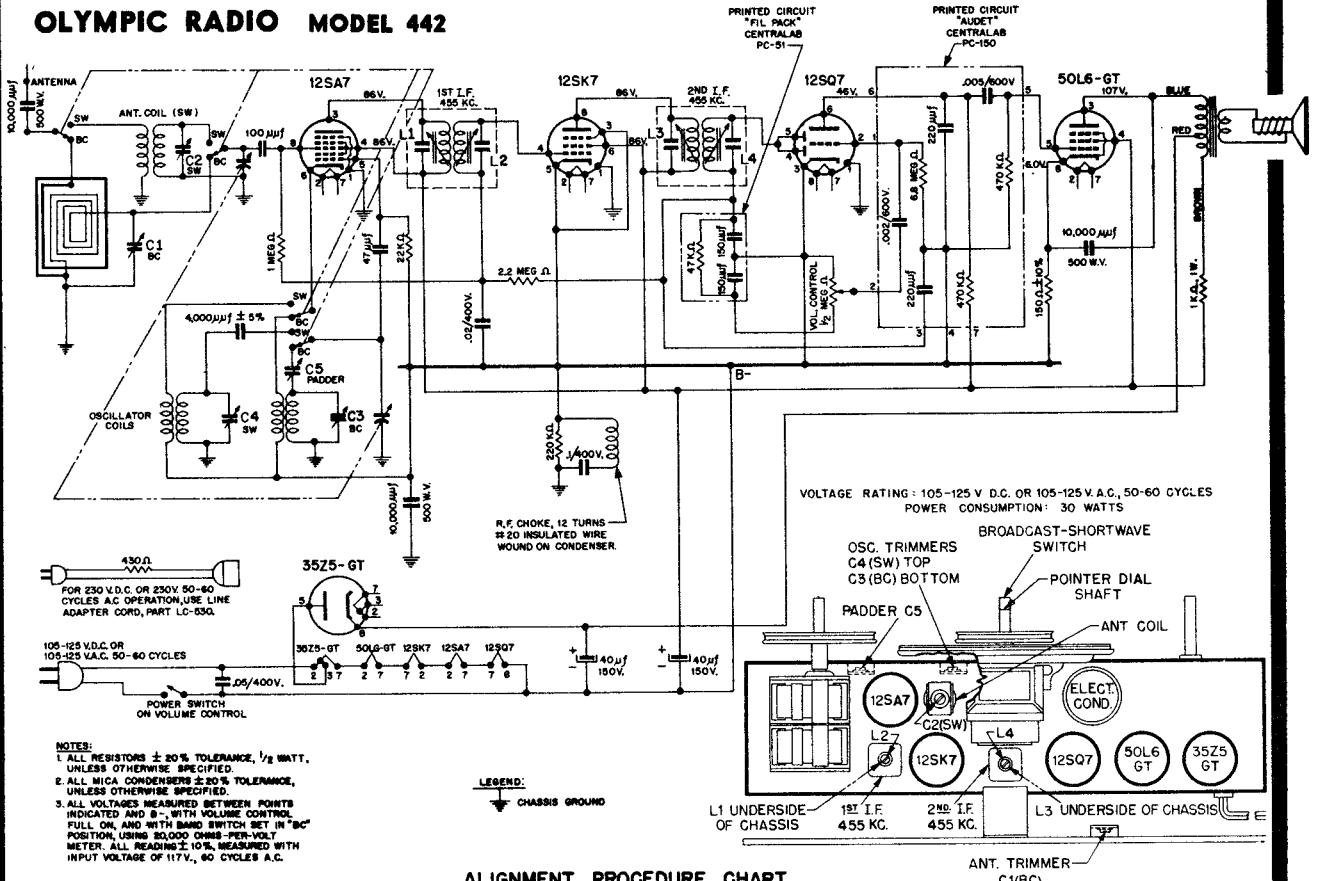

ALIGNMENT PROCEDURE CHART

STEP		CONNECT HIGH SIDE OF SIGNAL GENERATOR TO—	SET SIGNAL GENERATOR TO—	TURN RECEIVER DIAL TO—	ADJUST THE FOLLOWING FOR MAXIMUM OUTPUT. (KEEP SIGNAL FROM SIGNAL GENERATOR AS LOW AS POSSIBLE).
1	B.C.	R.F. SECTION OF VARIABLE CONDENSER OR PIN 4 OF THE 12SK7 TUBE IN SERIES WITH A .1MFD. 400 VOLT CONDENSER.	455 KC.	FULL CLOCKWISE POSITION (CONDENSER PLATES FULLY OPEN).	L4 AND L3 (2ND. I.F. TRANSFORMER)
2	B.C.	R.F. SECTION OF VARIABLE CONDENSER OR PIN 8 OF THE 12SA7 TUBE IN SERIES WITH A .1MFD. 400 VOLT CONDENSER.	455 KC.	FULL CLOCKWISE POSITION (CONDENSER PLATES FULLY OPEN).	L2 AND L1 (1ST. I.F. TRANSFORMER)
3	B.C.	REPEAT STEPS 1 AND 2			
4	B.C.	USE RADIATED SIGNAL (CONNECT BOTH SIDES OF SIGNAL GENERATOR TO RADIATION LOOP).	1500 KC.	1500KC. ON CALIBRATION LABEL (150 ON DIAL)	C 3 (OSCILLATOR TRIMMER)
5	B.C.		1500 KC.	MAXIMUM SIGNAL 1500KC. ON CALIBRATION LABEL	C 1 (ANTENNA TRIMMER)
6	B.C.		600 KC.	MAXIMUM SIGNAL 600KC. ON CALIBRATION LABEL	C5 (PADDER) ROCK VARIABLE FOR MAXIMUM SIGNAL
7	B.C.	REPEAT STEPS 4, 5, AND 6			
8	S. W.	ANTENNA WIRE ON LOOP IN SERIES WITH A 400 OHM CARBON RESISTOR.	15 MC.	15 MC. ON CALIBRATION LABEL	C4 (OSCILLATOR TRIMMER) SECOND PEAK FROM TIGHT POSITION C2 (ANTENNA TRIMMER). WHILE ADJUSTING C2, ROCK VARIABLE FOR MAXIMUM SIGNAL.
9	S. W.		5 MC.	RESONANCE (APPROX. 5 MC. ON CALIBRATION LABEL)	5 MC. CALIBRATION LINE (AT RESONANCE) COINCIDES WITH ALIGNMENT LINE ON STRAP. IF NOT REPEAT STEP 8.

MANUAL OF 1955 MOST-OFTEN-NEEDED RADIO DIAGRAMS

OLYMPIC RADIO & TELEVISION INC.

AM-PHONO 3-SPEED CHANGER COMBINATION MODEL HF 500

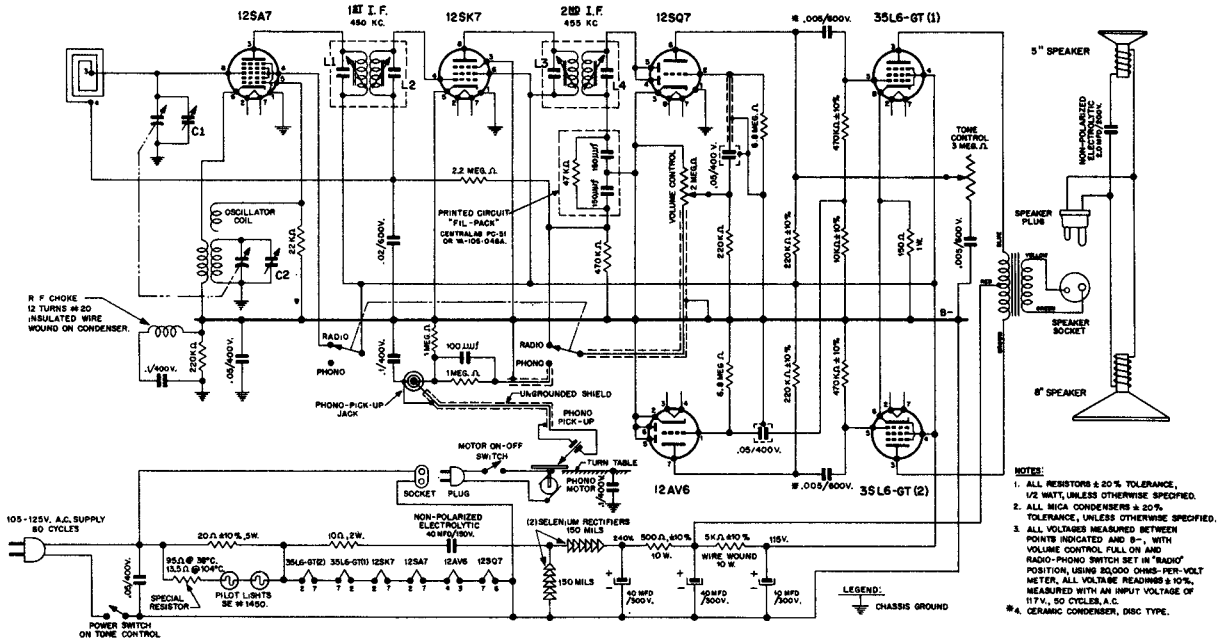

This alignment procedure chart applies to all models listed on this page.

ALIGNMENT PROCEDURE CHART

STEP	CORRECT HIGH SIDE OF SIGNAL GENERATOR TO -	SET SIGNAL GENERATOR TO -	TURN RECEIVER DIAL TO -	ADJUST THE FOLLOWING FOR MAXIMUM OUTPUT. (KEEP SIGNAL FROM SIGNAL GENERATOR AS LOW AS POSSIBLE)
1	ANTENNA SECTION TUNING CONDENSER IN SERIES WITH .1 MFD. COND.	455 KC.	FULL CLOCKWISE POSITION (CONDENSER PLATES FULLY OPEN)	L4, L3, L2, L1 AND REPEAT IN SAME ORDER (1st. AND 2nd. I.F. TRANSFORMERS)
2	USE RADIATED SIGNAL	1500 KC.	1500 KC. (150 ON DIAL)	C2 (OSCILLATOR)
3		1500 KC.	MAXIMUM SIGNAL (APPROX. 150 ON DIAL)	C1 (ANTENNA)
4	REPEAT STEPS 2 AND 3			

OLYMPIC AM-Phono Combination, Models 571 and 573

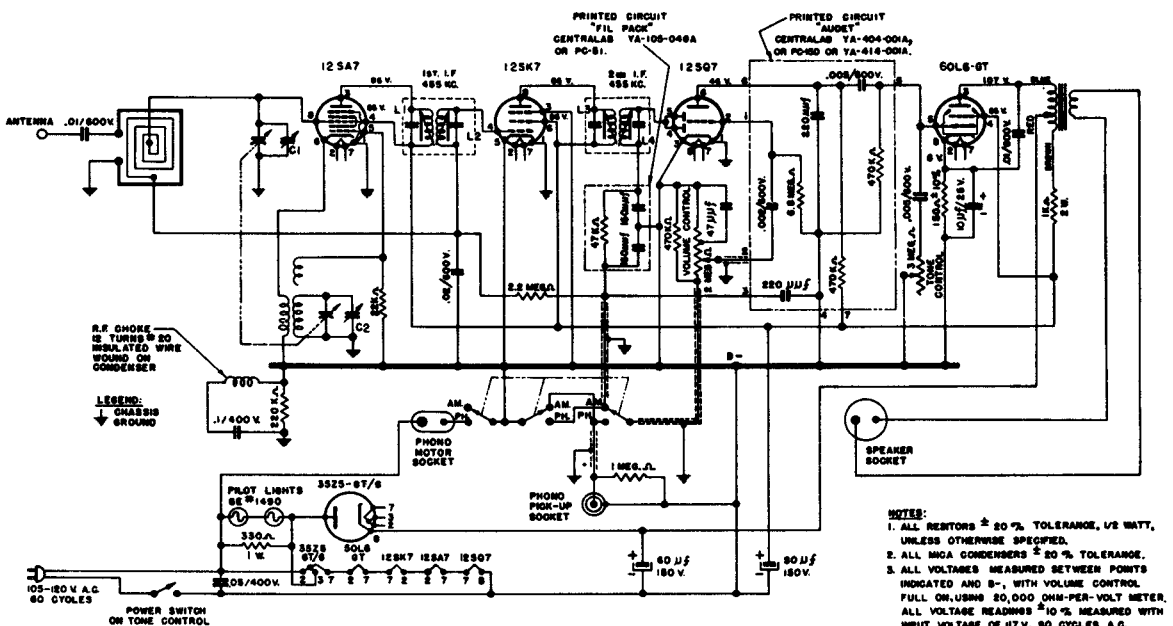

MANUAL OF 1955 MOST-OFTEN-NEEDED RADIO DIAGRAMS

Packard-Bell

MODEL 541 RADIO-PHONO

MODEL 543 CHAIRSIDE RADIO

Socket voltages measured under following conditions:

1. Line voltage 117 volts AC.
2. Volume control at maximum.
3. Switch in RADIO position.
4. VTVM between terminal and B minus.
5. Only DC voltages measured. Allow 10% tolerance.

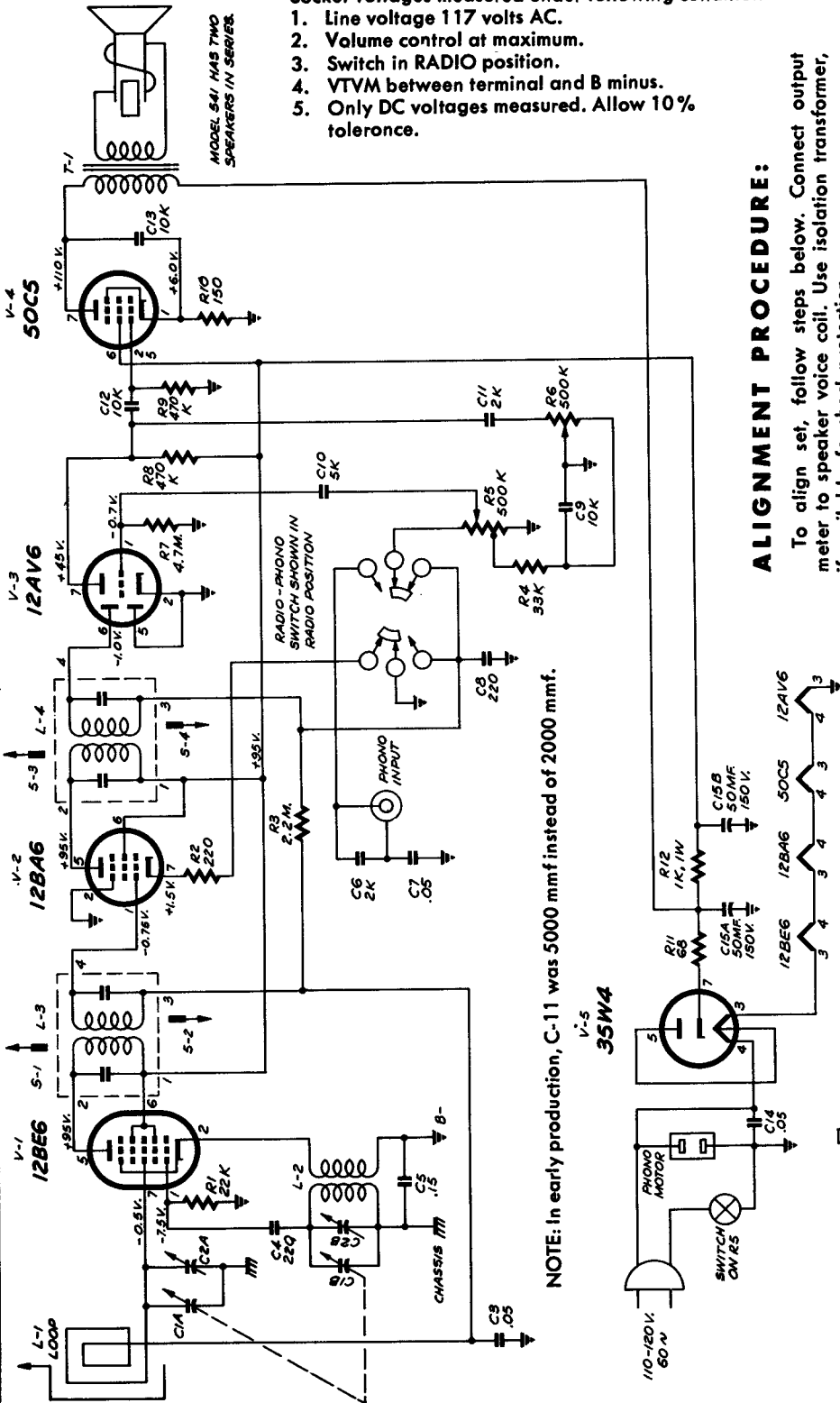

NOTE: In early production, C-11 was 5000 mmf instead of 2000 mmf.

ALIGNMENT PROCEDURE:

To align set, follow steps below. Connect output meter to speaker voice coil. Use isolation transformer, if available, for shock protection.

Each adjustment should be made using a minimum input signal. Connect test oscillator through a .01 mfd capacitor to the point indicated in chart.

STEP	CONNECT TEST OSCILLATOR TO	TEST OSCILLATOR FREQUENCY	RADIO DIAL SETTING	ADJUST
1.	Pin 1, V-1 (12BE6)	455 Kc.	540 Kc. S-1, S-2, S-3 & S-4 for MAX	
2.	Antenna Clip	1620 Kc.	1620 Kc. C-2B for MAX	
3.	Antenna Clip	1500 Kc.	Tune set to C-2A for MAX osc. signal	

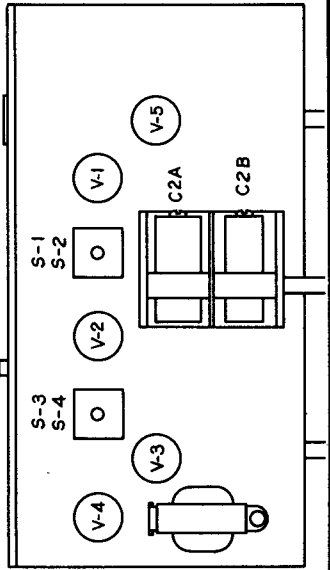

MANUAL OF 1955 MOST-OFTEN-NEEDED RADIO DIAGRAMS

PHILCO HOME RADIO MODELS C-579, C-580, C-716, C-718 and C-720

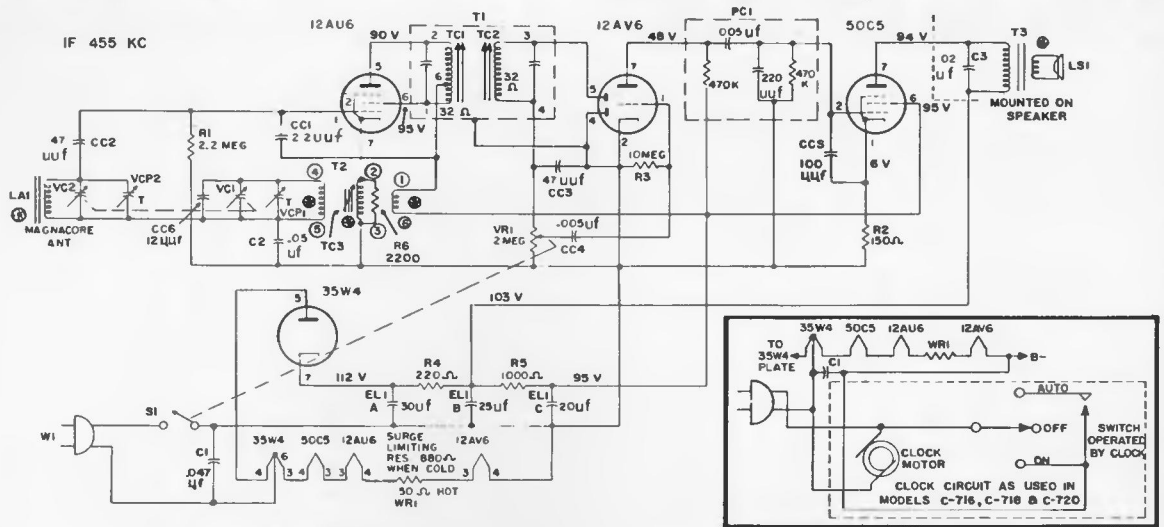

ALIGNMENT PROCEDURE

GENERAL — Allow the set and test equipment to warm up for fifteen minutes before starting alignment procedure.

TUNING DIAL — Before proceeding with the alignment, set the tuning knob indicator so that it is in a horizontal position, just pass the "55" dial mark, when the gang is fully closed.

OUTPUT INDICATOR — Connect the output indicator (a 1000 ohms-per-volt, a-c voltmeter, or an oscilloscope) across the voice-coil terminals.

SIGNAL GENERATOR — Use an AM r-f signal generator. Connect the ground lead to B—, and connect the output lead as indicated in the alignment chart.

OUTPUT LEVEL — Attenuate the signal-generator output throughout the alignment so as to maintain the output level below 0.4 volt.

RADIO CONTROLS — Set the volume control to maximum. Set the tuning control as indicated in the alignment chart.

SPECIFICATIONS

CABINET	Moulded plastic
CIRCUIT	Three tube autodyne (plus rectifier)
FREQUENCY RANGE	540 KC to 1620 KC
AUDIO OUTPUT	1 Watt
OPERATING VOLTAGE	Models C-579 & C-580 105 to 120v., ac or dc Models C-716 & C-718 105 to 120v., ac
POWER CONSUMPTION	30 Watts
AERIAL	Self Contained Magnacore
INTERMEDIATE FREQUENCY	455KC
PHILCO TUBES	12AU6 Converter-oscillator, 12AV6 detector 1st audio, 50C5 output and 35W4 rectifier

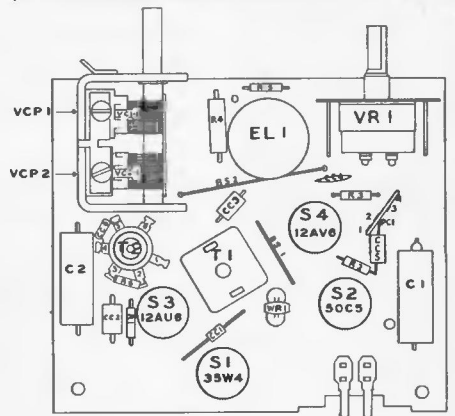

NOTE: In Clock Models, the switch on VR1 is removed and a wire is added between wiring panel and clock.

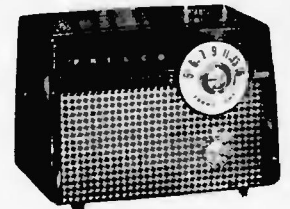

MODEL C-580



MODEL C-718

NOTE: Use a 6-to-8 turn, 6-inch diameter loop made of insulated wire. Connect to generator terminals, and place about one foot from radio loop.

ALIGNMENT CHART

Step	SIGNAL GENERATOR		RADIO		Adjust
	Connection to Radio	Dial Setting	Special Instructions	Dial Setting	
1	Connect signal generator through a .1 ml. condenser to antenna section of tuning gang.	455 KC	Adjust for maximum output in order given.	Tuning gang fully opened	TC2 I-F sec. TC1 I-F pri.
2	Use radiating loop	1620 KC	Adjust for maximum output.	Gang fully opened	VCP-2 osc. trim.
3	Same as Step 2	1400 KC	Adjust for maximum output.	1400 KC	VCP-1 ant. trim.
4	Repeat Steps 2 and 3 until no further improvement is obtained.				

MANUAL OF 1955 MOST-OFTEN-NEEDED RADIO DIAGRAMS PHILCO MODELS C-583, C-721 and C-723 (All Code 124)

C-584 (124), C-722 (124), & C-724 (124)

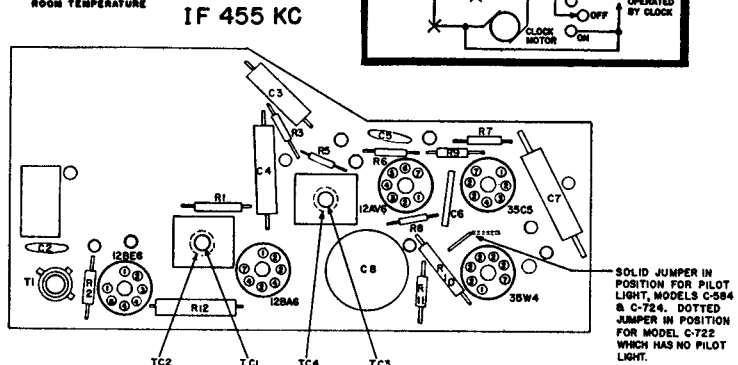
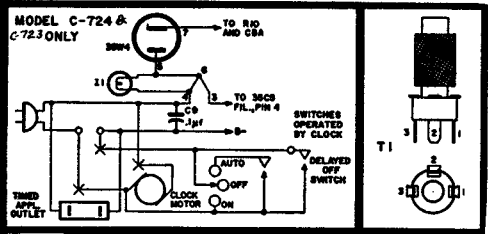
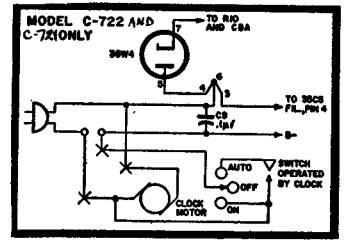
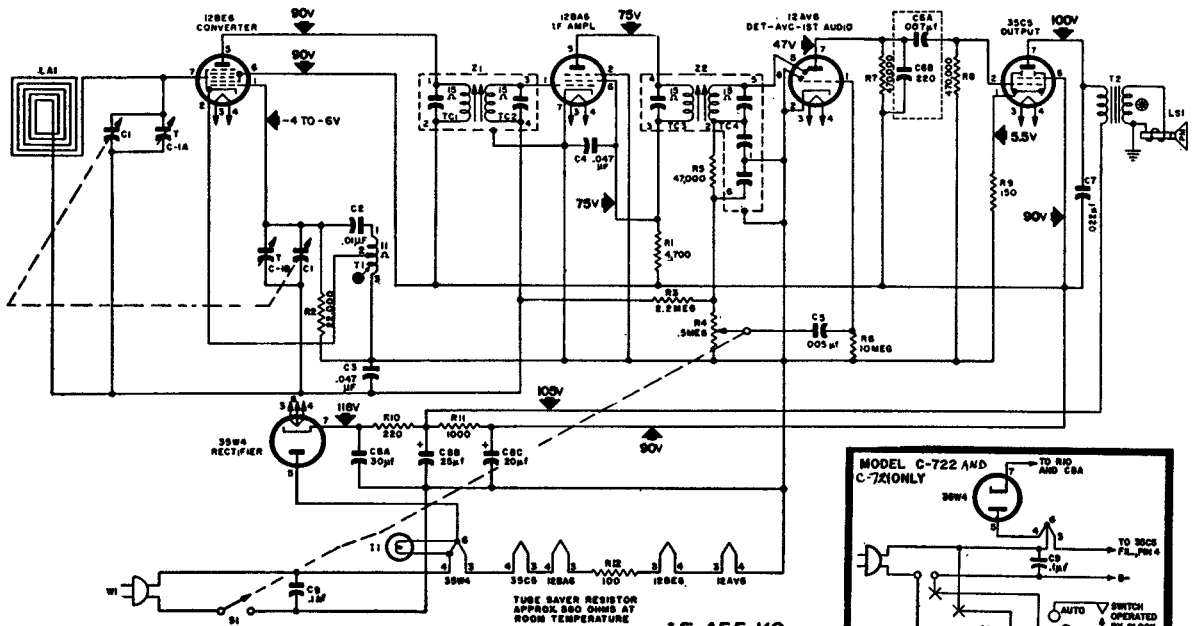

NOTES:
ALL VOLTAGES MEASURED WITH A 20,000 OHMS-PER-VOLT VOLTMETER BETWEEN POINTS INDICATED AND B MINUS, AT A LINE VOLTAGE OF 117V AC.
OSCILLATOR GRID VOLTAGE MEASURED ACROSS R1, WITH A 100,000 OHM ISOLATING RESISTOR IN SERIES WITH METER.
ALL RESISTOR VALUES ARE IN OHMS AND ALL CONDENSER VALUES IN μ F UNLESS OTHERWISE INDICATED.
⊙ INDICATES LESS THAN 1 OHM.
X INDICATES CLOCK SOCKET CONNECTIONS.

ALIGNMENT PROCEDURE

RADIO CONTROLS — Set volume control to maximum. Set tuning control as indicated in chart.

OUTPUT METER — Connect across voice-coil terminals.

OUTPUT LEVEL — During alignment, adjust signal-generator output to hold output-meter reading below .5 volts.

ALIGNMENT CHART

STEP	SIGNAL GENERATOR		RADIO		ADJUST
	CONNECTION TO RADIO	DIAL SETTING	DIAL SETTING	SPECIAL INSTRUCTIONS	
1	Ground lead to B—; output lead through a .1-mf. condenser to grid (pin 7) of 12BE6.	455 KC	Tuning gang fully open	Adjust tuning cores, in order given, for maximum output. TC1 and TC3 are located at top of transformers.	TC4—2nd i-f sec. TC3—2nd i-f pri. TC2—1st i-f sec. TC1—1st i-f pri.
2	Radiating loop (See note below).	1620 KC	1620 KC *	Adjust trimmer for maximum output.	C1-B — osc.
3	Same as step 2.	1500 KC	1500 KC	Adjust trimmer for maximum output.	C1-A — aerial

NOTE: Make up a 6-8 turn, 6 inch diameter loop from insulated wire, connect to signal-generator leads, and place near radio loop.
* For proper adjustment of the oscillator trimmer, fully open the tuning gang and insert a .006 inch non-metallic shim between the heel of the rotor and the top of the stator plates. Close the tuning gang sufficiently to hold the shim in place, and then remove the shim without disturbing the gang setting.

MANUAL OF 1955 MOST-OFTEN-NEEDED RADIO DIAGRAMS PHILCO PORTABLE RADIO MODEL C-661

MODEL C-662



MODEL C-662

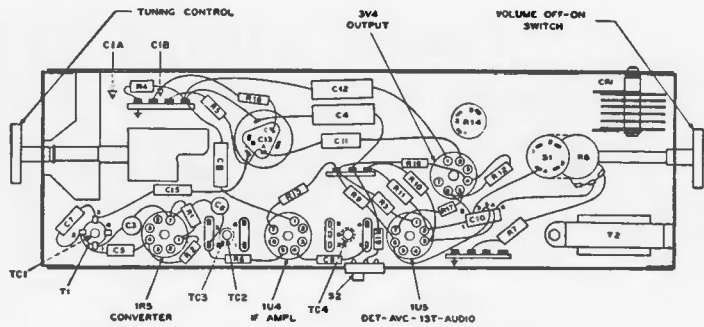

ALIGNMENT CHART

STEP	SIGNAL GENERATOR		RADIO		ADJUST
	CONNECTION TO RADIO	DIAL SETTING	DIAL SETTING	SPECIAL INSTRUCTIONS	
1	Connect signal generator through a .1- μ f. condenser to pin 6 (converter grid) of 1R5.	455 kc.	Tuning gang fully open.	Adjust for maximum output in order given.	TC4—2nd i-f sec. TC2—1st i-f pri. TC3—1st i-f sec.
2	Use radiating loop. (See NOTE 1 below.)	1620 kc.	1620 kc. (mark on extreme right.)	Adjust for maximum output.	C1B—osc. trimmer
3	Same as step 2.	1400 kc.	1400 kc. (second mark from right.)	Adjust for maximum output.	C1A—antenna trimmer
4	Same as step 2.	600 kc.	600 kc. (See NOTE 2 below.)	Adjust for maximum output. Rock tuning gang while making this adjustment.	TC1—osc. core
5	Repeat steps 2, 3, and 4 until no further improvement is obtained.				

NOTE 1. Use a 6-to-8-turn, 6-inch-diameter loop made up of insulated wire. Connect to generator terminals, and place about one foot from radio loop.

NOTE 2. The tuning condenser can be set to the proper frequency by turning it until the dial pointer coincides with the respective marks on the dial backplate.

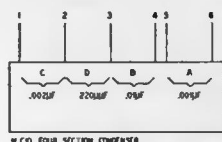
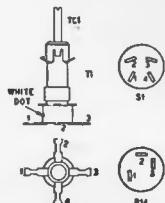
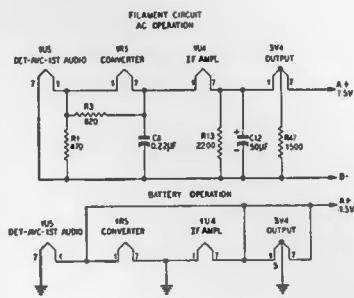
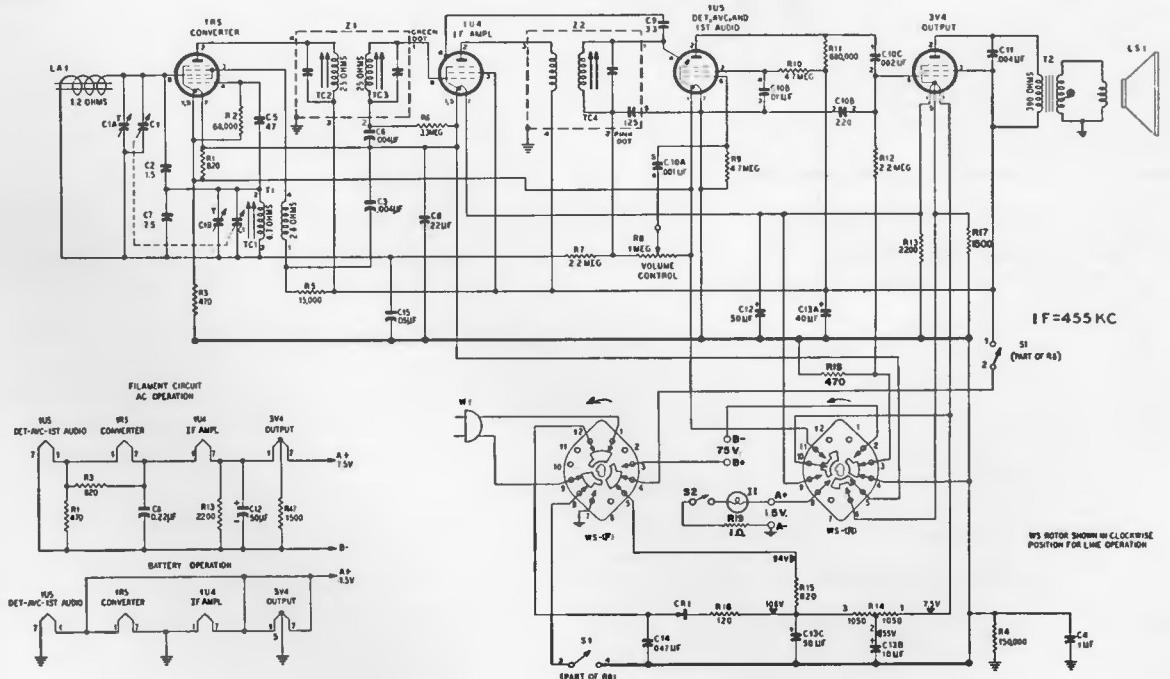

	1R5	1U4	1U5	3V4
B SUPPLY	90	55	90	90
IF PLATE PIN 2	90	55	90	90
IF PLATE PIN 3	90	55	90	90
SCREEN PLATE PIN 2	90	55	90	90
SCREEN PLATE PIN 3	90	55	90	90
SCREEN PLATE PIN 4	90	55	90	90
SCREEN PLATE PIN 5	90	55	90	90

SPECIFICATIONS

CABINET: PLASTIC PORTABLE
 CIRCUIT: FOUR-TUBE SUPERHETERODYNE (PLUS SELENIUM RECTIFIER)
 AUDIO OUTPUT: 180 MILLIWATTS
 A-C OR D-C OPERATION: 85 MILLIWATTS
 BATTERY OPERATION: 85 MILLIWATTS
 OPERATING VOLTAGE: .87 VOLTS, A-C OR DC
 1.5-VOLT "B" BATTERY AND 75-VOLT "B" BATTERY

POWER CONSUMPTION: 31 WATTS
 A-C OR D-C OPERATION: 30 MA FROM 75-VOLT "B" BATTERY
 BATTERY OPERATION: 240 MA FROM 1.5-VOLT "B" BATTERY

ANTENNA: MAGNECOR HIGH-IMPEDANCE LOOP
 INTERMEDIATE FREQUENCY: 455 KC
 PHILCO TUBES: 1R5 CONVERTER, 1U4 IF AMPLIFIER, 1U5 DETECTOR-AVC-1ST AUDIO, 3V4 OUTPUT

BATTERY TYPE: #14 "B" BATTERY (D P7 "X" BATTERIES)

MANUAL OF 1955 MOST-OFTEN-NEEDED RADIO DIAGRAMS

PHILCO PORTABLE RADIO MODEL C-663

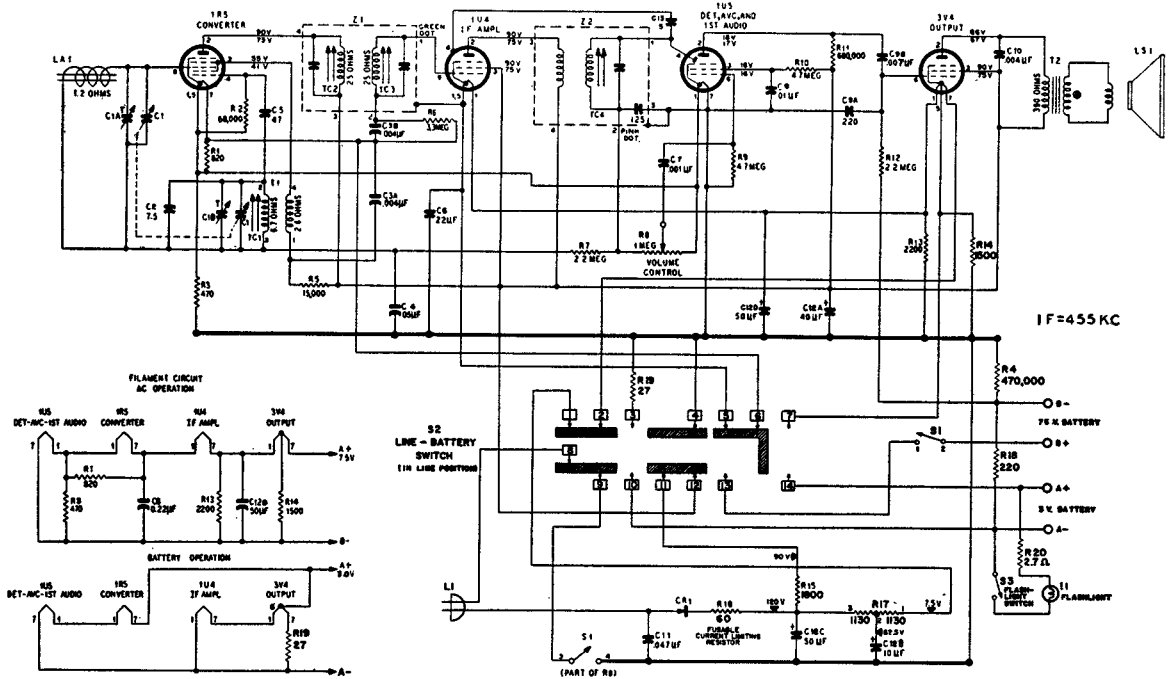

ALIGNMENT PROCEDURE

Dial Indicator — Before alignment, the dial knob should be set as follows: with the condenser gang plates fully meshed, the first knob marking (past the 550 KC point) should be perpendicular to the front of the chassis.

Output Indicator — Connect a 1000-ohms-per-volt a-c voltmeter or an oscilloscope across the voice-coil terminals.

Signal Generator — Use an AM r-f signal generator. Connect the ground lead to B—, and connect the output lead as indicated in the alignment chart.

STEP	SIGNAL GENERATOR		RADIO		ADJUST
	CONNECTION TO RADIO	DIAL SETTING	DIAL SETTING	SPECIAL INSTRUCTIONS	
1	Connect signal generator through a .1 mfd condenser to pin 6 (converter grid) of 1R5.	455 kc.	Tuning gang fully open.	Adjust for maximum output in order given.	TC4—2nd I-F sec. TC3—1st I-F sec. TC2—1st I-F pri.
2	Use radiating loop (See note one below).	1620 kc.	1620 kc. (See note 2 below).	Adjust for maximum.	C1B—osc. trimmer
3	Same as step 2.	1400 kc.	1400 kc. (Tune for signal.)	Adjust for maximum.	C1A—ant. trimmer
4	Same as step 2.	600 kc.	600 kc. (Tune for signal.)	Adjust for maximum output. Rock tuning gang while making this adjustment.	TC1—Osc. core
5	Repeat steps 2, 3, and 4 until no further improvement is noted.				

NOTE 1: Use a 6- to 8 turn, 6 inch diameter loop made up of insulated wire. Connect to generator terminals, and place about one foot from radio loop.

NOTE 2: The tuning condenser can be set to the proper frequency for the oscillator adjustment as follows: Fully open the tuning gang and insert a .006 non-metallic shim between the heel of the rotor and the top of the stator plates. Close the gang sufficiently to hold the shim in place, and then remove the shim without disturbing the gang setting.

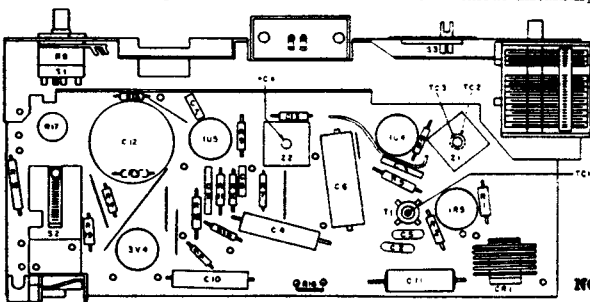

SPECIFICATIONS

CABINET..... PLASTIC PORTABLE

CIRCUIT..... 5T6 TYPE SUPERHETERODYNE (PLUS SELENIUM RECTIFIER)

ADJUST. OUTPUT..... 450 MWS OPERATION - 150 MILLIWATTS

BATTERY OPERATION - 75 MILLIWATTS

SUPPLY VOLTAGE..... 117 VOLTS, AC 50 Hz

POWER..... 3.0 WATT INPUT & 75 VOLT "B" BATTERY

AC 50 Hz OPERATION..... 11 WATTS

CONSUMPTION..... 100 MA FROM "A"

ANTENNA..... WIRELESS OR NON-INDUCTIVE LOOP

INTERMEDIATE FREQUENCY..... 455 KC

PHILCO TUNING..... 1R5 CONVERTER, 1U4 1F AMPLIFIER

1U5 DETECTOR-1ST I-F AMP, 3V4 OUTPUT

BATTERY TYPES..... 9-60 "B" BATTERY

USE "B" "B" BATTERIES

FLASHLIGHT BULB TYPE..... P2-4, PHILCO PART NUMBER 3462-E

NOTES

VOLTS-RESISTORS IN OHMS, CONDENSERS IN PPF UNLESS OTHERWISE NAMED...

© 1955 TRIM I CORP.

*VOLTS INDICATED WITH A 10,000 OHM-100-VOLT METER FROM "B"

THE VOLTAGE-TAP VOLTAGE WITH LINE SUPPLY, BOTTOM VOLTAGE WITH BATTERY.

NOTES: R20 wired between positive "A" battery terminal and the flashlight socket assembly. Jumpers are indicated by solid lines.

MANUAL OF 1955 MOST-OFTEN-NEEDED RADIO DIAGRAMS

PHILCO RADIO MODEL C-667 (Code 121)

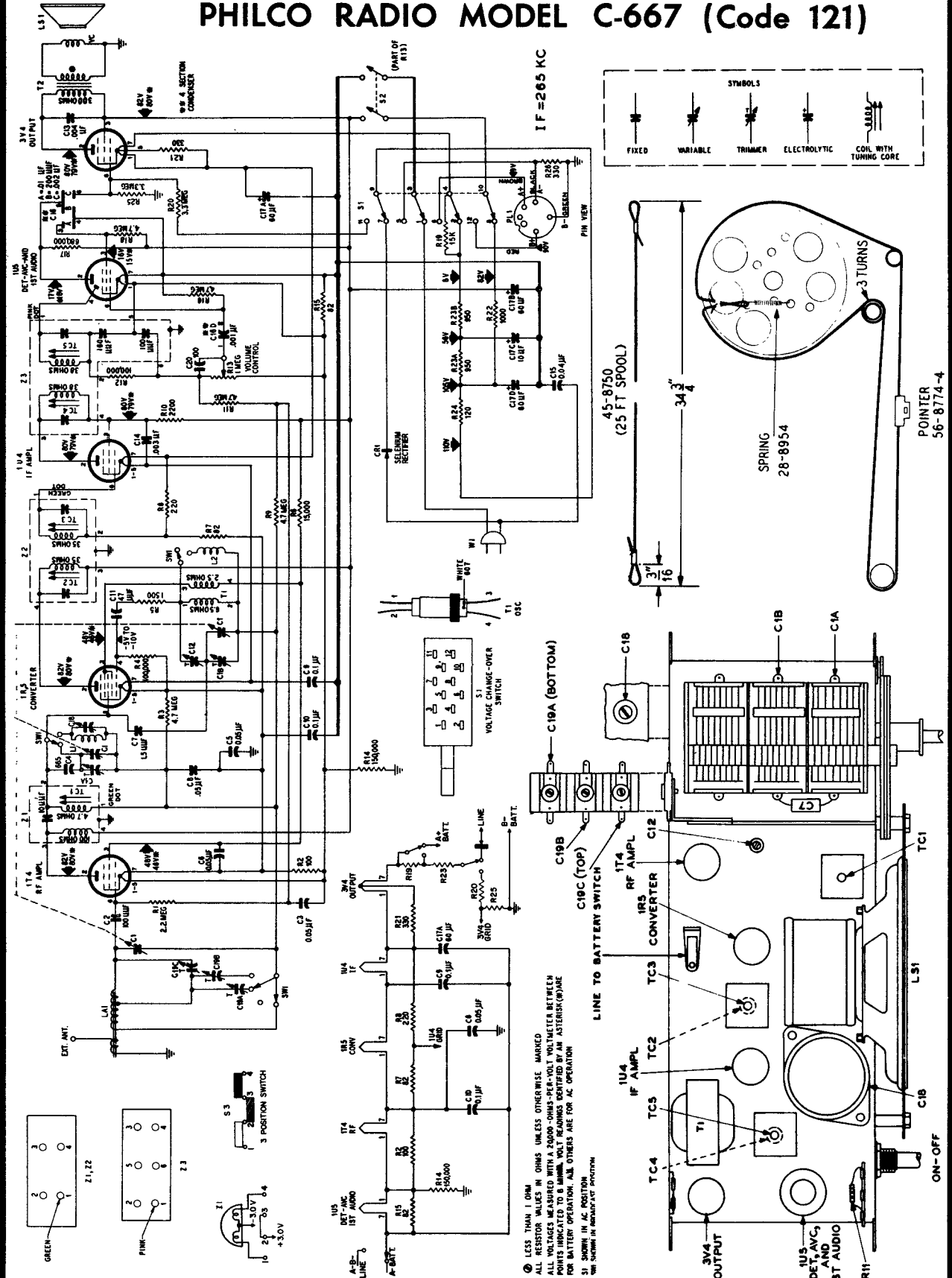

* LESS THAN 1 OHM
 ALL RESISTOR VALUES IN OHMS UNLESS OTHERWISE MARKED
 ALL VOLTAGES MEASURED WITH A 2000-OHM-PER-VOLT VOLTMETER BETWEEN
 POINTS INDICATED BY A MINUS SIGN. VOLT READINGS VERIFIED BY AN ASTERISK (*) ARE
 FOR BATTERY OPERATION. ALL OTHERS ARE FOR AC OPERATION
 S1 SHOWN IN AC POSITION
 SW SHOWN IN BATTERY POSITION

MANUAL OF 1955 MOST-OFTEN-NEEDED RADIO DIAGRAMS

PHILCO

MODELS C-1334, C-1340, C-1341, C-1342, C-1343

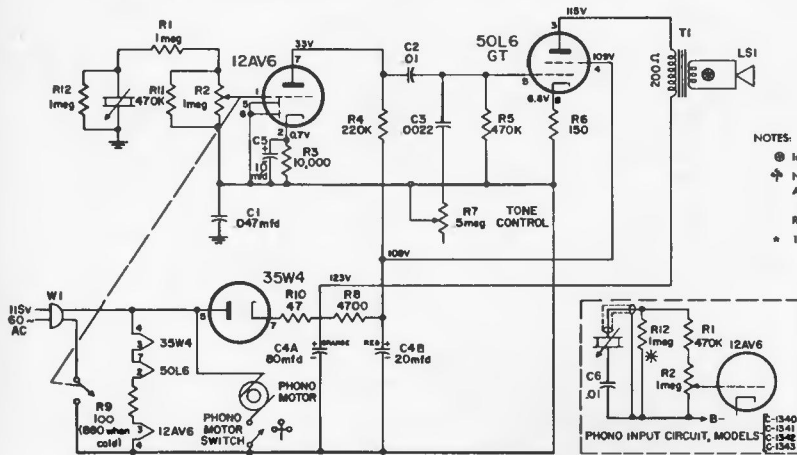

NOTES:
 Ⓞ Indicates resistance of less than 1 ohm.
 † Not used in Model C-1334.
 All voltages measured with a 10,000 ohms/volt meter from B- to point indicated.
 R9 Tube Saver Resistor drops 15V when hot.
 * 1 megohm, used in Model C-1340 (with M-24) only.

Model C-1334 Schematic (for Models C-1340 to C-1343 see inset)

SPECIFICATIONS

Circuit — Two tube amplifier plus rectifier.

Audio Output — 1.0 watt.

Operating Voltage — 105 to 125 volts, 60 cycles, A.C.

Power Consumption — 55 watts.

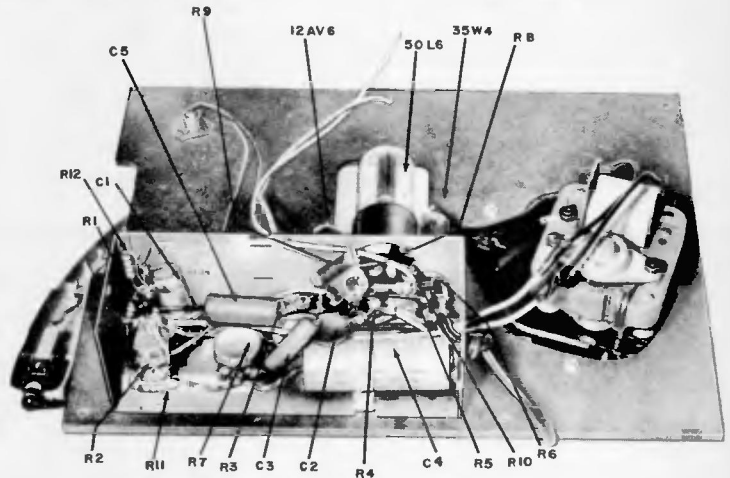

PHILCO HI-FIDELITY PHONOGRAPHS

MODELS C-1347 and C-1755

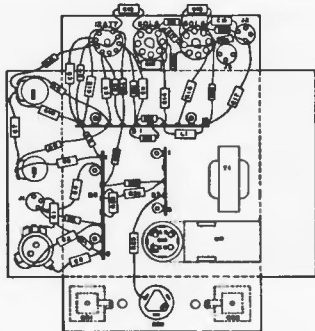

Base View — Models C-1347 and C-1755

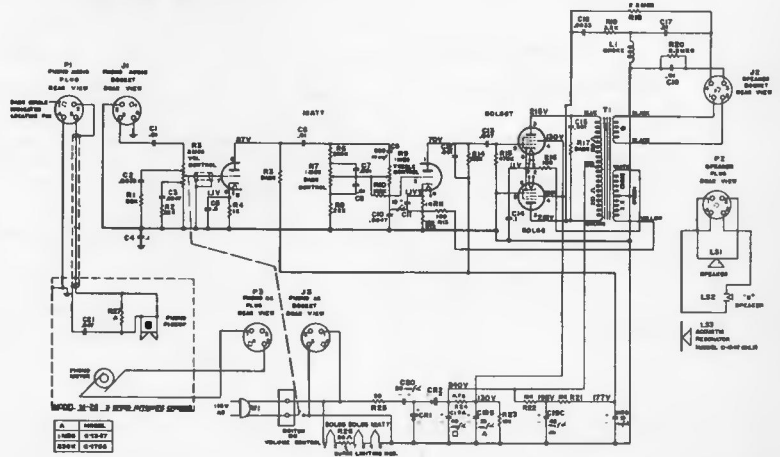

MANUAL OF 1955 MOST-OFTEN-NEEDED RADIO DIAGRAMS

PHILCO RADIO-PHONOGRAPH MODEL C1348

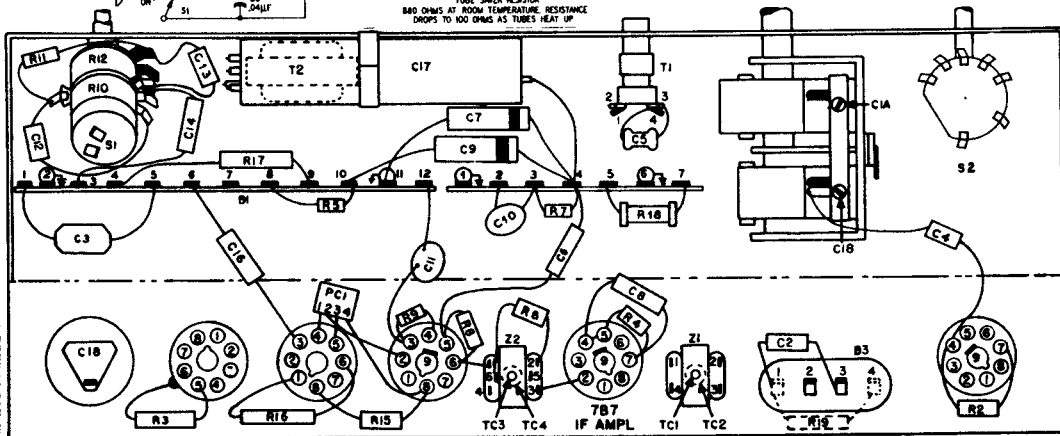
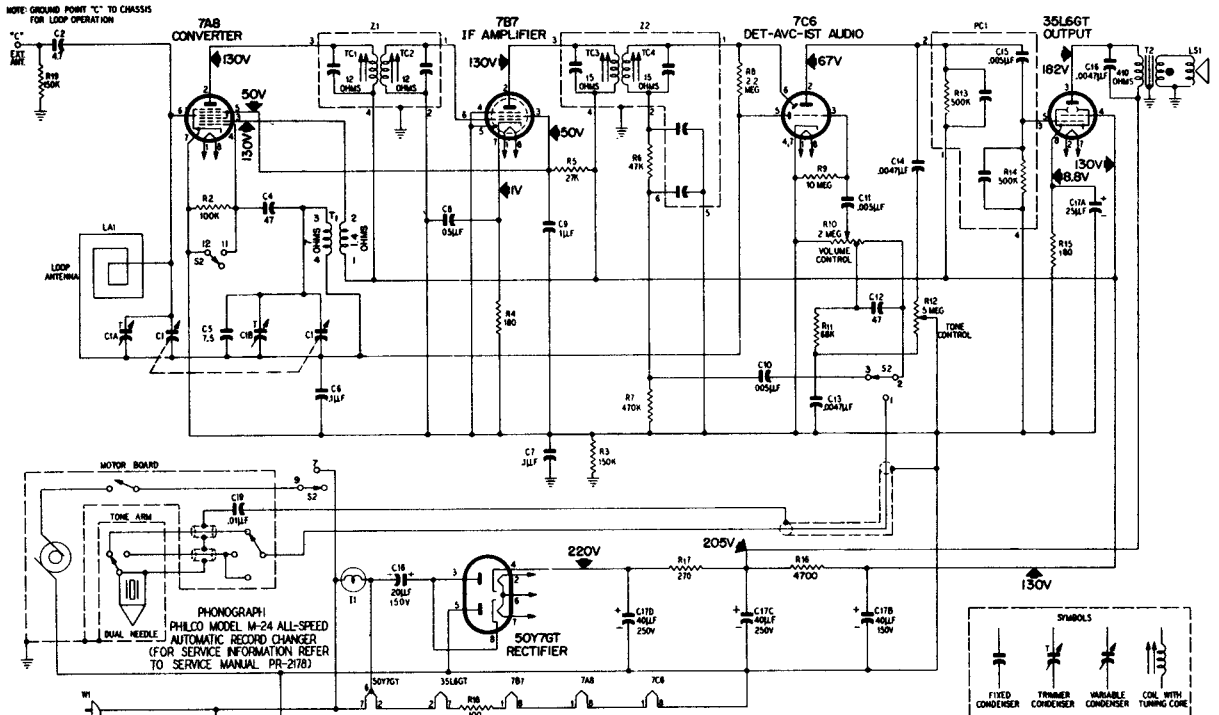

ALL RESISTOR VALUES IN OHMS UNLESS OTHERWISE SPECIFIED. ALL CONDENSER VALUES IN μ F UNLESS OTHERWISE SPECIFIED. p LESS THAN 1 OHM. ALL VOLTAGES MEASURED BETWEEN POINT INDICATED AND B.

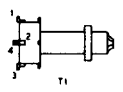
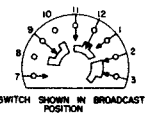

50Y7GT RECTIFIER 35L6GT OUTPUT 7C6 DET. AVC-1ST AUDIO **ALIGNMENT CHART** 7A8 CONVERTER

STEP	SIGNAL GENERATOR		RADIO		ADJUST TRIMMER
	CONNECTION TO RADIO	DIAL SETTING	DIAL SETTING	SPECIAL INSTRUCTIONS	
1	Output lead through a .01- μ f. condenser to grid (pin 6) of 7A8 converter tube.	455 kc. (modulated)	Gang fully open	Adjust, in order given in next column, for maximum output. TC2 and TC4 are located at top of transformers.	TC4—2nd i-f sec. TC3—2nd i-f pri. TC2—1st i-f sec. TC1—1st i-f pri.
2	Radiating loop. (See NOTE 1 below.)	1620 kc.	1620 kc. (See NOTE 2 below.)	Adjust for maximum output.	C1B—oscillator trimmer
3	Same as step 2.	1520 kc.	1520 kc. (See NOTE 2 below.)	Adjust for maximum output.	C1A—antenna trimmer

NOTE 1: Make up a 6—8 turn, 6-inch-diameter loop from insulated wire; connect to signal-generator leads, and place near radio loop.
 NOTE 2: The tuning gang can be set to 1620 kc. and 1520 kc. by turning the tuning control until the pointer coincides with the respective marks on the dial backplate.

MANUAL OF 1955 MOST-OFTEN-NEEDED RADIO DIAGRAMS



RCA VICTOR

MODEL 3-HS-61

Chassis No. RS-145A

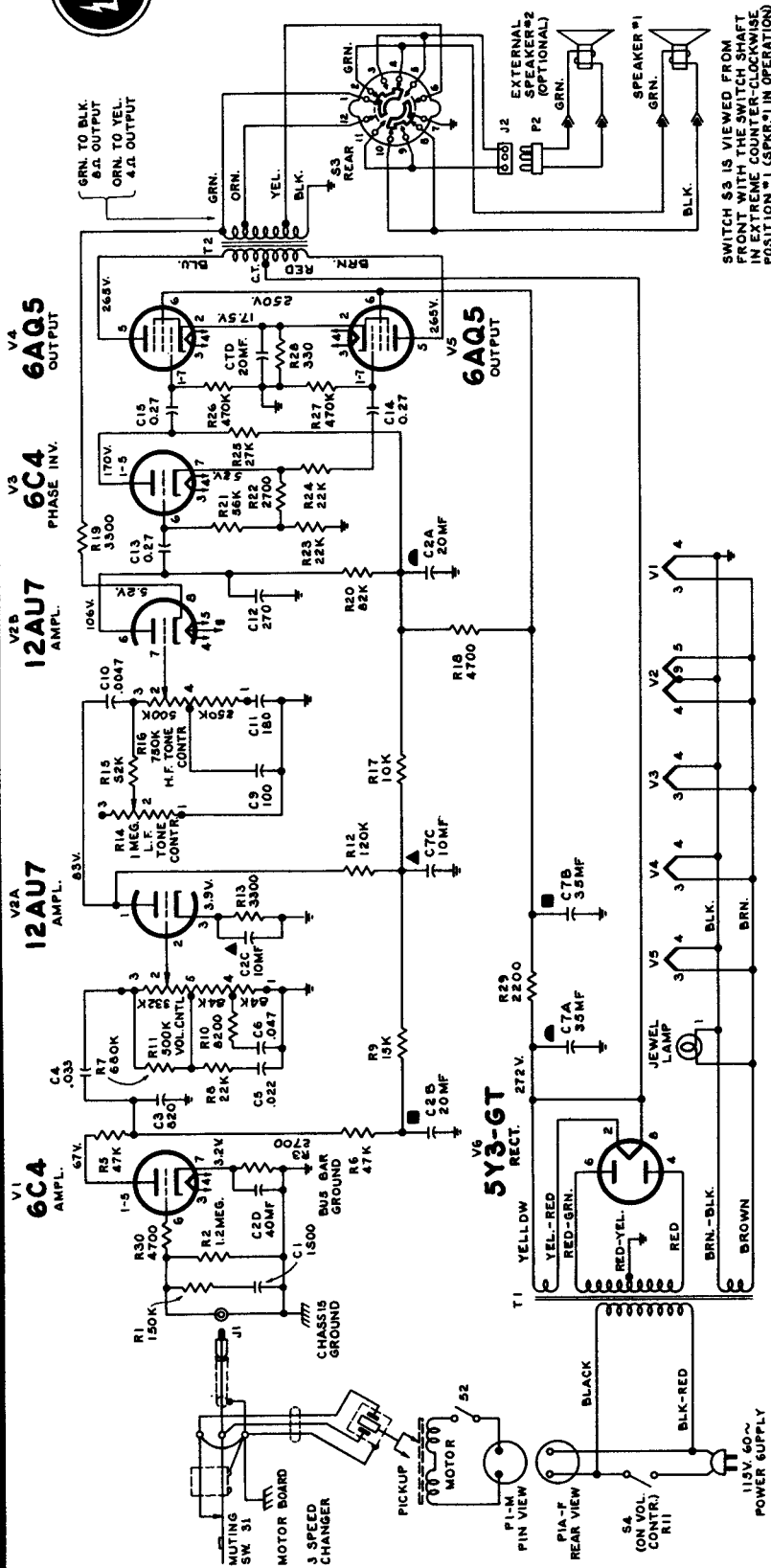

REVERSING THE LEADS TO EITHER SPEAKER WILL RESULT IN DISTORTION AND LOW VOLUME ON TWO SPEAKER OPERATION.

For record changer information see material on RP-197 Series, pages 95-102, SUPREME Vol. 14, 1954 Radio Diagrams Manual.

CRITICAL LEAD DRESS

1. Dress all capacitors except C3, and C12 against chassis.
2. Dress R29 at least 3/4 inch away from chassis and transformer.
3. Dress all heater leads close to chassis.
4. Keep leads on R1, R2, R30, and C1 as short as possible.

SWITCH S3 IS VIEWED FROM FRONT WITH THE SWITCH SHAFT IN EXTREME COUNTER-CLOCKWISE POSITION #1 (SPKR #1 IN OPERATION)

V1	6C4	7	1.2 MA.
V2A	12AU7	3	1.2 MA.
V2B	12AU7	9	1.5 MA.
V3	6C4	2	24.1 MA.
V4	6AQ5	2	24.1 MA.
V5	6AQ5	2	24.1 MA.
V6	5Y3GT	5	54.3 MA.

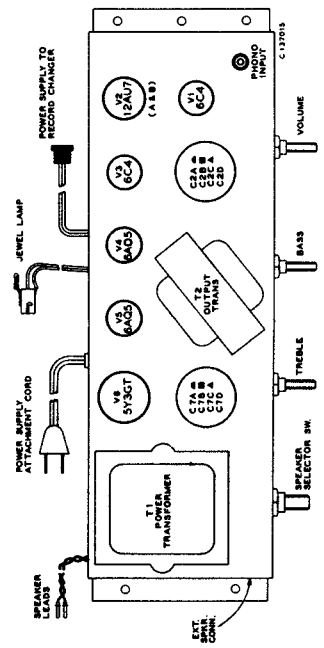

RCA VICTOR

MODELS 3-US-5, 3-US-5A

Chassis No. RC-1130

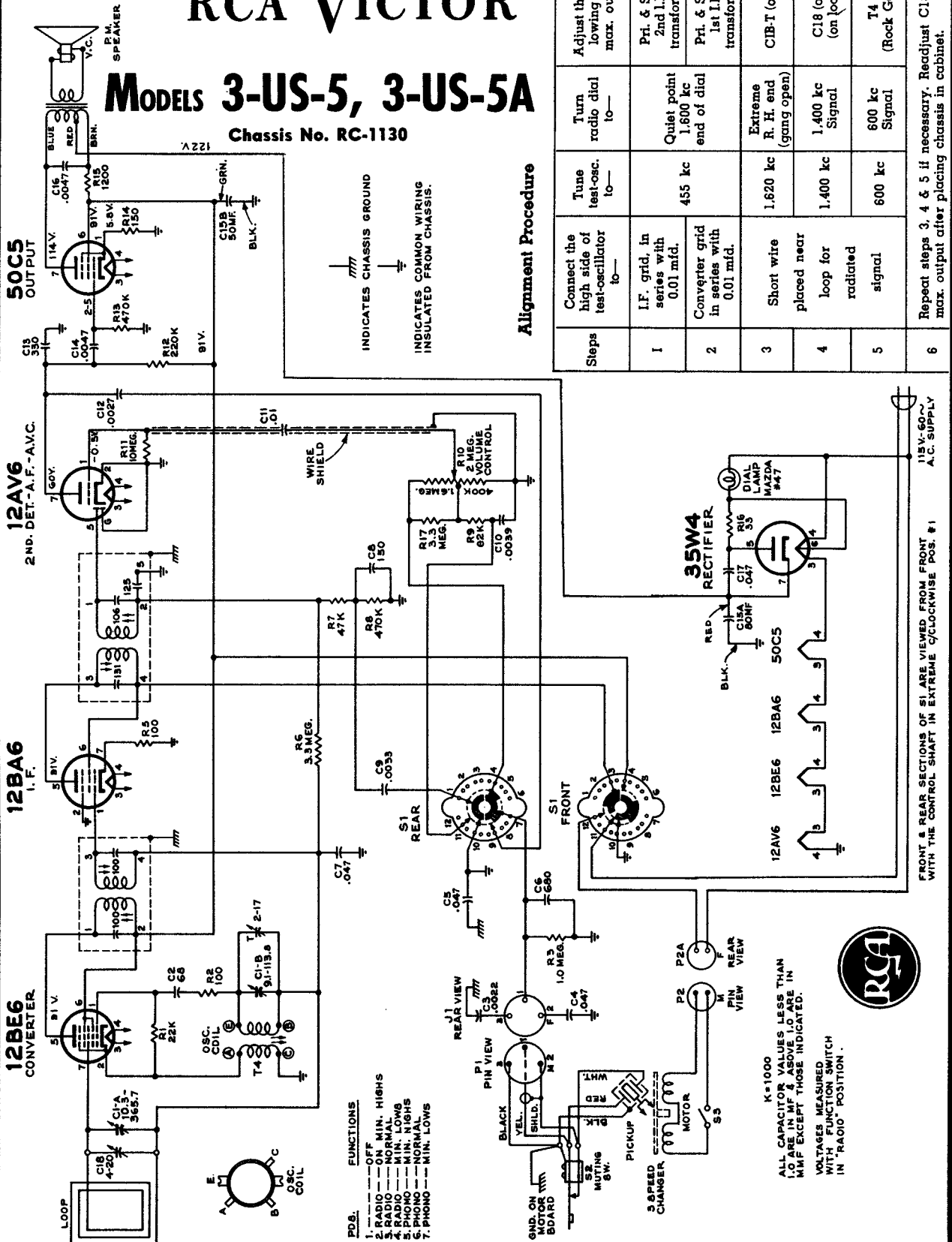

INDICATES CHASSIS GROUND
 INDICATES COMMON WIRING INSULATED FROM CHASSIS.

Alignment Procedure

Steps	Connect the high side of test-oscillator to—	Tune test-osc. to—	Turn radio dial to—	Adjust the following for max. output
1	I.F. grid, in series with 0.01 mfd.	455 kc	Quiet point end of dial	Pri. & Sec. 2nd I.F. transformer
2	Converter grid in series with 0.01 mfd.	1.620 kc	1,600 kc	Pri. & Sec. 1st I.F. transformer
3	Short wire placed near radiated signal	1.400 kc	Extreme R. H. end (gang open)	CIB-T (osc.)
4	loop for radiated signal	600 kc	1,400 kc Signal	C18 (ant.) (on loop)
5	600 kc signal	600 kc	600 kc Signal	T4 (Rock Gang)
6	Repeat steps 3, 4 & 5 if necessary. Readjust C18 for max. output after placing chassis in cabinet.			

FRONT & REAR SECTIONS OF S1 ARE VIEWED FROM FRONT WITH THE CONTROL SHAFT IN EXTREME C/CLOCKWISE POS. #1

- P.D.B. FUNCTIONS**
- 1. RADIO — OFF
 - 2. RADIO — MIN. HIGHS
 - 3. RADIO — NORM.
 - 4. RADIO — MIN. LOWS
 - 5. PHONO — MIN. HIGHS
 - 6. PHONO — NORMAL
 - 7. PHONO — MIN. LOWS

K=1000
 ALL CAPACITOR VALUES LESS THAN 1.0 ARE IN MF & ABOVE 1.0 ARE IN MMF EXCEPT THOSE INDICATED.
 VOLTAGES MEASURED WITH FUNCTION SWITCH IN "RADIO" POSITION.



MANUAL OF 1955 MOST-OFTEN-NEEDED RADIO DIAGRAMS

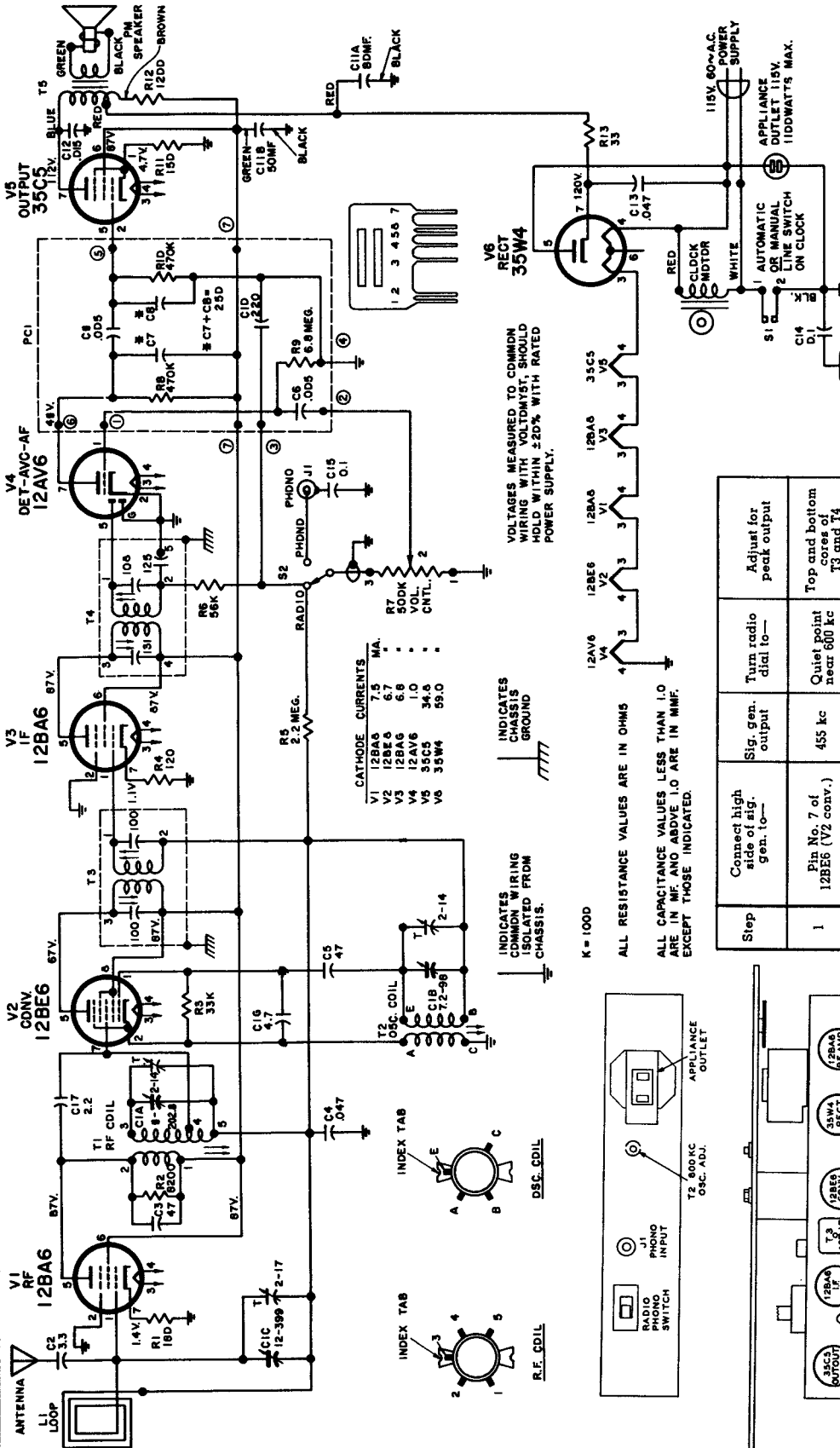

RCA VICTOR

4-C-671, 4-C-672

Chassis No. RC 1142

Step	Connect high side of sig. gen. to—	Sig. gen. output	Turn radio dial to—	Adjust for peak output
1	Pin No. 7 of 12BE6 (V2 conv.)	455 kc	Quiet point near 600 kc	Top and bottom cores of T3 and T4
2		1620 kc	Gang open	C1-B Osc.
3		1400 kc	1400 kc signal	C1-A R.F. C1-C Ant.
4	"External Antenna" terminal	Shunt C1-A with 22,000 ohm resistor 600 kc	600 kc	T2 Osc. (Rock gang)
5		Remove 22,000 ohm resistor from C1-A 600 kc	600 kc	T1 R.F.
6			Repeat steps 3, 4 and 5	

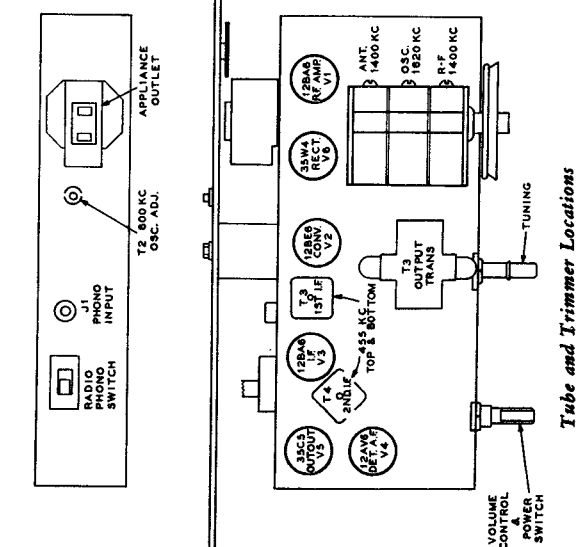

MANUAL OF 1955 MOST-OFTEN-NEEDED RADIO DIAGRAMS



RCA VICTOR

4-C-541 SERIES

Chassis No. RC-1145

The material on this page and on the page adjacent at right, is exact for Models 4C541, 4C542, 4C543, 4C544, 4C545, 4C547, Chassis RC-1145. Models 4C531, 4C532, 4C533, 4C534, 4C535, Chassis RC-1144 are similar electrically to RC-1145, but omit radio-phono switch S2 and outlet J2. Models 4X551, 4X552, 4X553, 4X554, 4X555, Chassis RC-1146, and Models 5X560, 5X562, 5X564, Chassis RC-1150, are also similar electrically to Chassis RC-1145 described on these two pages, but omit clock mechanism.

Alignment Procedure

Test-Oscillator—For all alignment operations, connect the low side of the test-oscillator to the receiver chassis, and keep the oscillator output as low as possible to avoid a-v-c action.

An isolation transformer (115/115 v.) may be necessary for the receiver if the test-oscillator is also a.c. operated.

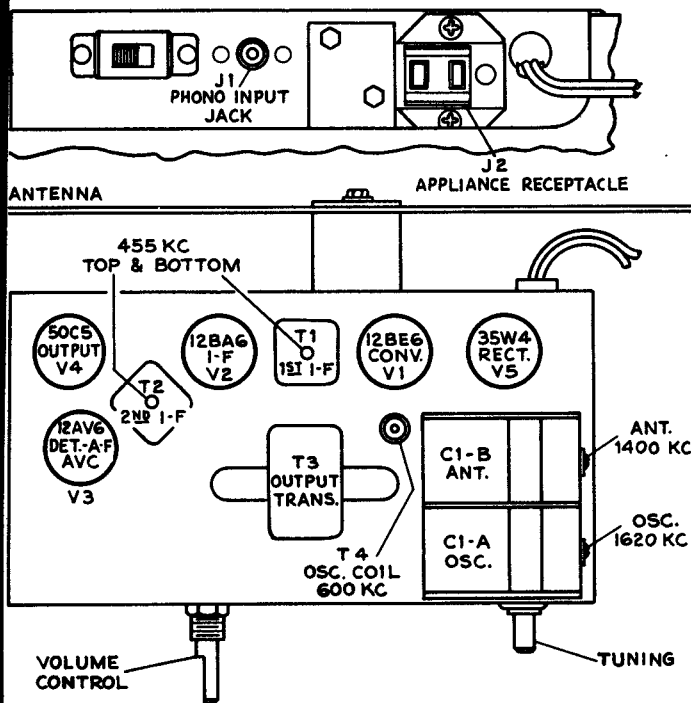

Step	Connect the high side of test-oscillator to—	Tune test-osc. to—	Turn radio dial to—	Adjust the following for max. output
1	12BA6 I-F grid through .01 mfd. capacitor	455 kc	Quiet-point 1,600 kc end of dial	T2 (top and bottom) 2nd I-F trans.
2	Stator of C1-B through .01 mfd.			T1 (top and bottom) 1st I-F trans.
3	Short wire placed near loop to radiate signal	1,620 kc	Max. clockwise	osc. trimmer C1-A
4		1,400 kc	1,400 kc signal	ant. trimmer C1-B
5		600 kc	600 kc signal	osc. coil T-4 (rock gang)
6	Repeat steps 3, 4, and 5			

Tube and Trimmer Locations

This material is applicable only to Chassis RC-1150, Models 5X560, 5X562, 5X564.

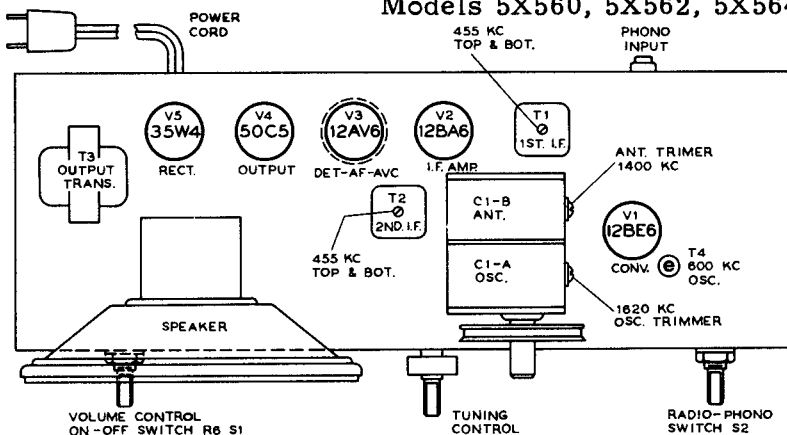

Tube and Trimmer Locations

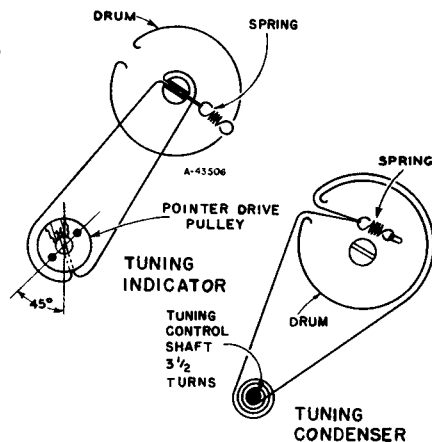

Diagram of Drive Cord with Condenser Rotor Closed (Extreme Counter-clockwise Position)

MANUAL OF 1955 MOST-OFTEN-NEEDED RADIO DIAGRAMS

RCA Victor Series 4C541, Chassis RC-1145, and others (Material continued)



RCA VICTOR

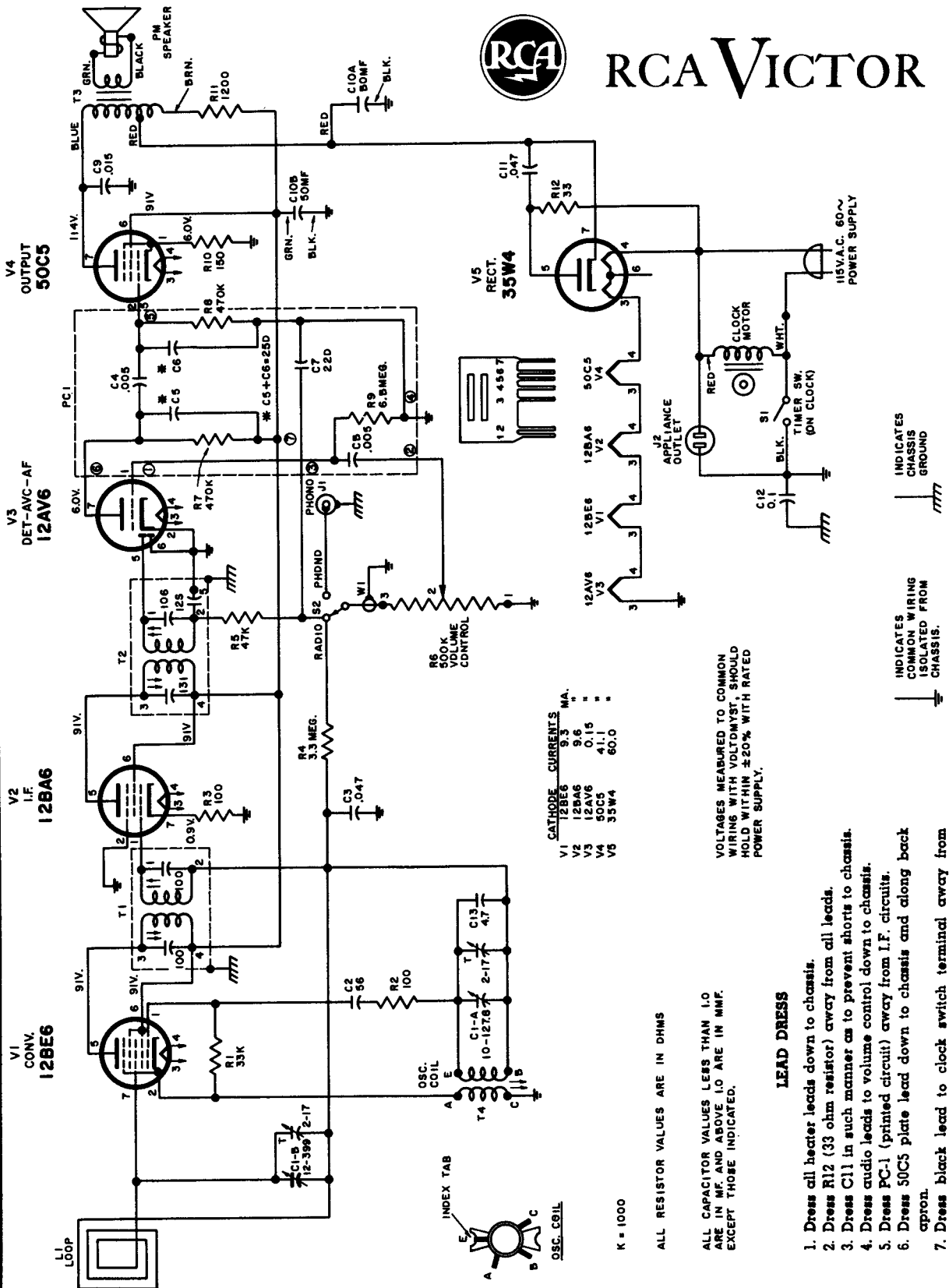

CATHODE CURRENTS

V1	V2	V3	V4	V5
12BE6	12BA6	12AV6	50C5	35W4
9.3 MA.	9.6	0.15	41.1	60.0

VOLTAGES MEASURED TO COMMON WIRING WITH VOLTOHMST, SHOULD HOLD WITHIN ±20% WITH RATED POWER SUPPLY.

ALL RESISTOR VALUES ARE IN OHMS

ALL CAPACITOR VALUES LESS THAN 1.0 ARE IN MF. AND ABOVE 1.0 ARE IN MMF. EXCEPT THOSE INDICATED.

LEAD DRESS

1. Dress all heater leads down to chassis.
2. Dress R12 (33 ohm resistor) away from all leads.
3. Dress C11 in such manner as to prevent shorts to chassis.
4. Dress audio leads to volume control down to chassis.
5. Dress PC-1 (printed circuit) away from I.F. circuits.
6. Dress 50C5 plate lead down to chassis and along back apron.
7. Dress black lead to clock switch terminal away from mechanism of clock switch.

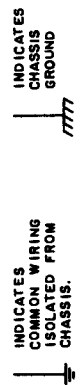

MANUAL OF 1955 MOST-OFTEN-NEEDED RADIO DIAGRAMS

RCA VICTOR

MODEL 4-X-661

Chassis No. RC-1141, RC-1141A

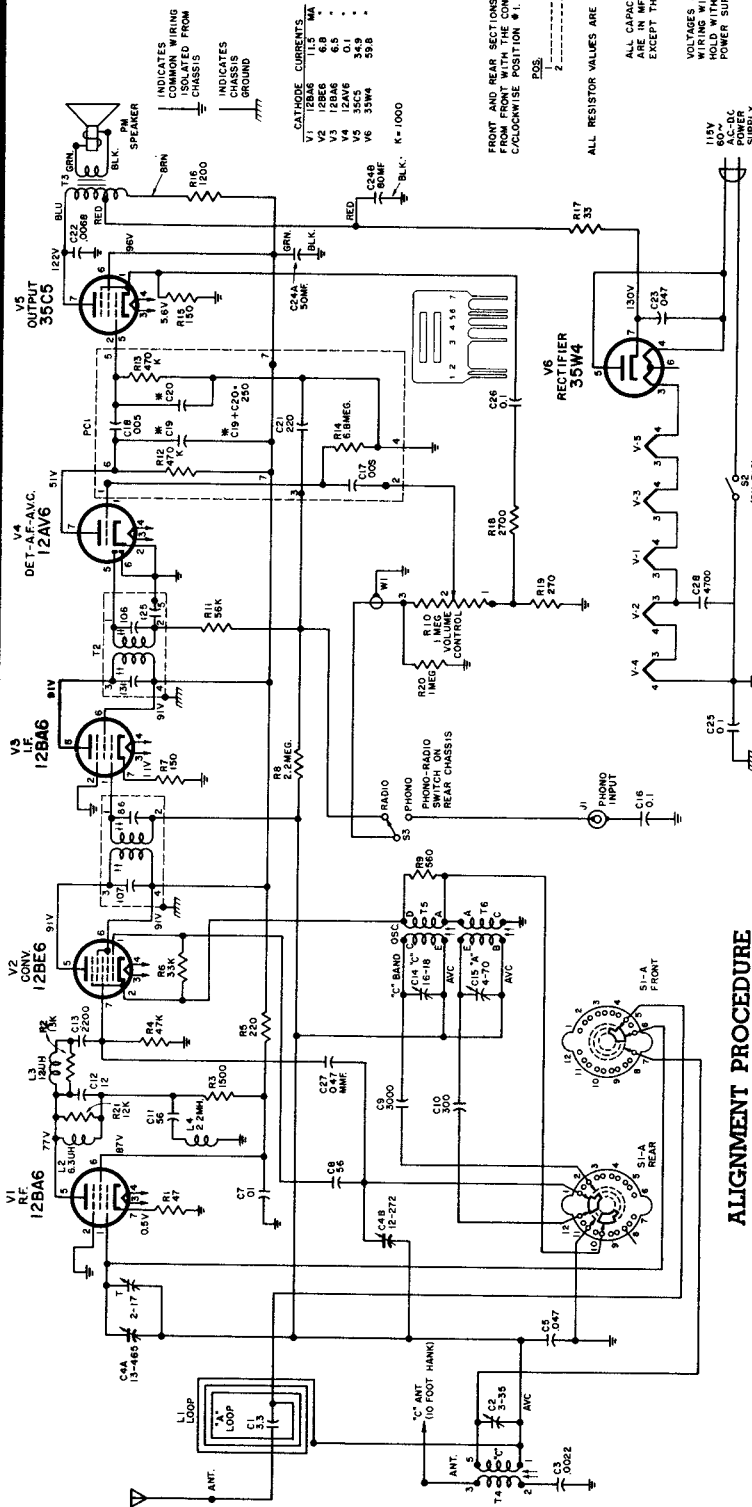

FRONT AND REAR SECTIONS OF SIA-SIA ARE VIEWED FROM FRONT WITH THE CONTROL SHAFT IN EXTREME C/CLOCKWISE POSITION #1.

FUNCTION BAND POSITION
 1 - BAND
 2 - BAND

ALL RESISTOR VALUES ARE IN OHMS

ALL CAPACITOR VALUES LESS THAN 1.0 MF ARE IN MMF EXCEPT THOSE INDICATED.

VOLUME MEASURES TO COMMON WINDING WITH VOLTAUNT C HOLD WITHIN ±20% WITH RATED POWER SUPPLY

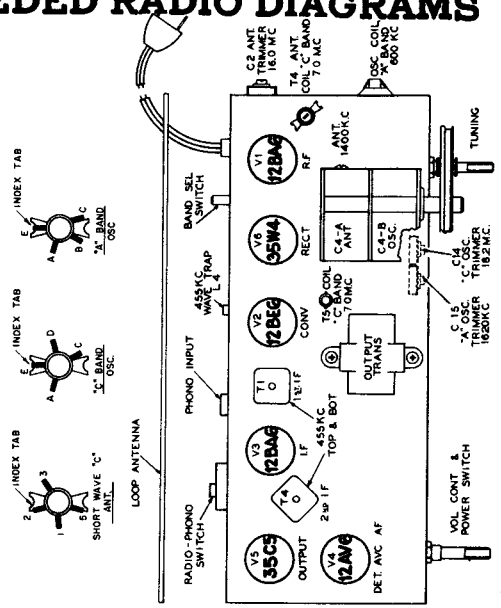

ALIGNMENT PROCEDURE

Steps	Connect the High Side of the Test Osc. to—	Tune Test Osc. to—	Range Switch to—	Turn Radio Dial to—	Adjust for maximum output
1	Pin No. 7 of 12BE6 Converter tube in series with 0.1 mfd.	455 kc.	"A"	Quiet Point near 1600 kc.	Top and bottom T2 2nd I.F. Trans. *Top and bottom T1 1st I.F. Trans. L4 wave trap for minimum output
2	Pin No. 1 of 12BA6 R.F. tube in series with 0.1 mfd.	1620 kc.	"A"	1620 kc. (Cap. min.)	C-15 "A" Osc.
3		1400 kc.	"A"	1400 kc.	C4A "A" ant. Trimmer
4		600 kc.	"A"	600 kc.	T6 "A" Osc. Rocking gang.
5	(Radiated signal) short piece of wire placed near ant.	16.2 mc.	"C"	16.2 mc. (Min. cap.)	**C-14 "C" Osc.
6	Repeat steps 3, 4 and 5.	16.0 mc.	"C"	16.0 mc.	***C-2 "C" Ant.
7		7.0 mc.	"C"	7.0 mc.	†††5 "C" Osc. †††4 "C" Ant.
8	Through 47 mmi. capacitor to jumper wire to "C" Band Ant. Coil.				
9					
10					Repeat steps 7, 8, and 9 as necessary.

MANUAL OF 1955 MOST-OFTEN-NEEDED RADIO DIAGRAMS

RCA VICTOR

Radio Phonograph Combination

MODEL 4-Y-511

Chassis No. RC 1134

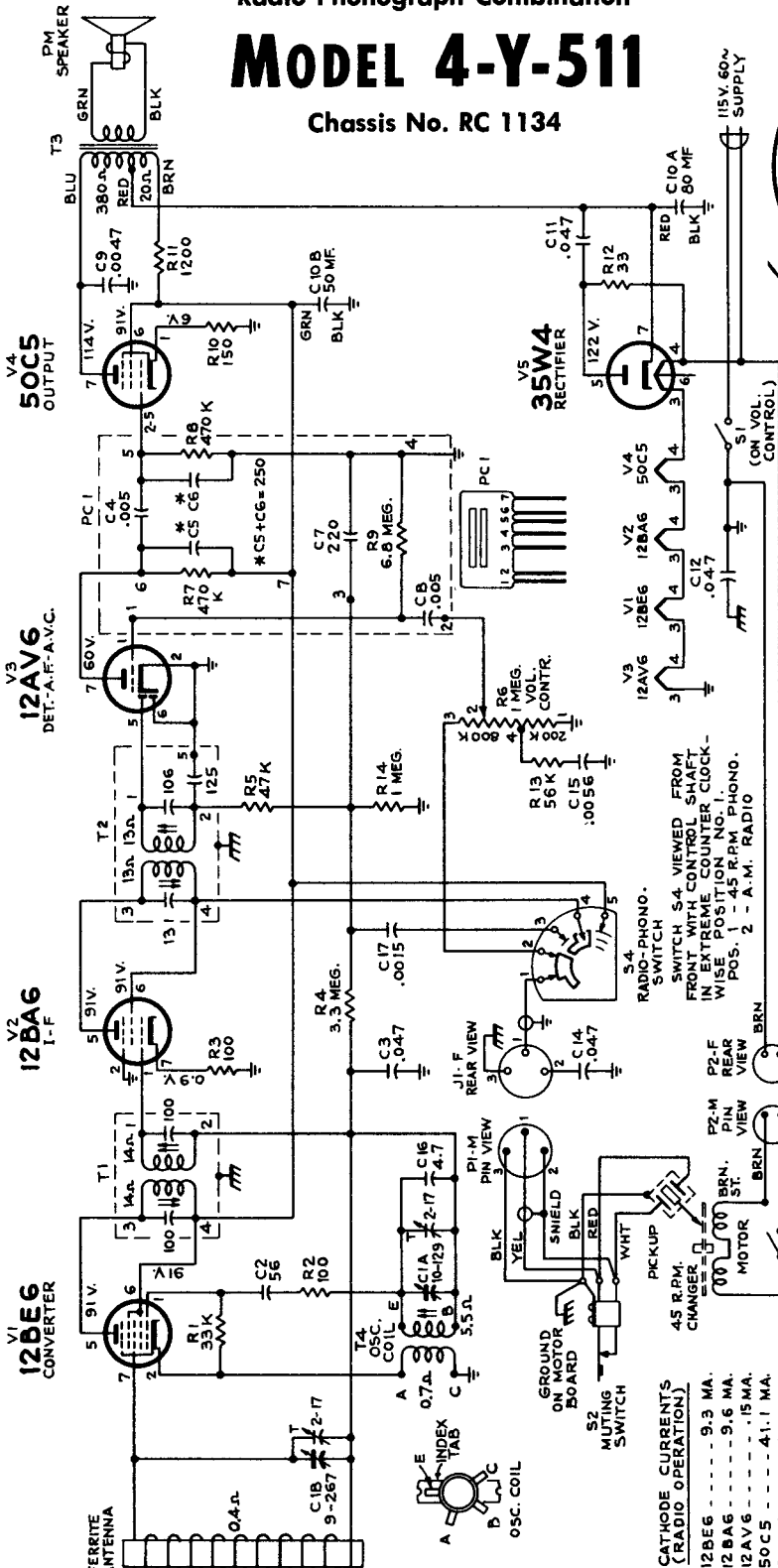

CATHODE CURRENTS (RADIO OPERATION)

12BE6	9.3 MA.
12BA6	9.6 MA.
12AV6	15 MA.
50C5	41.1 MA.
35W4	6D.1 MA.

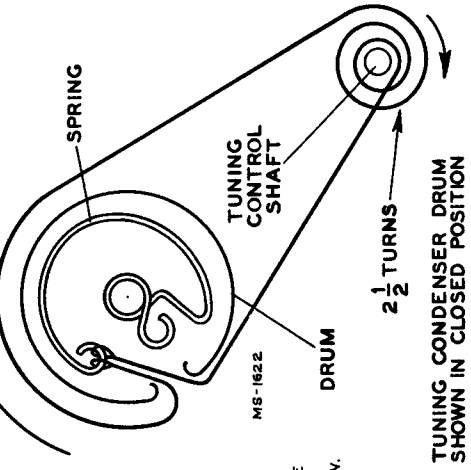

MS-1622

INDICATES COMMON WIRING INSULATED FROM CHASSIS

INDICATES CHASSIS GROUND

RESISTANCE VALUES IN OHMS. K=1000
 CAPACITANCE VALUES LESS THAN 1 IN MF AND ABOVE 1 IN MMF, UNLESS OTHERWISE NOTED.
 VOLTAGES MEASURED WITH FUNCTION SW. IN "RADIO" POSITION.

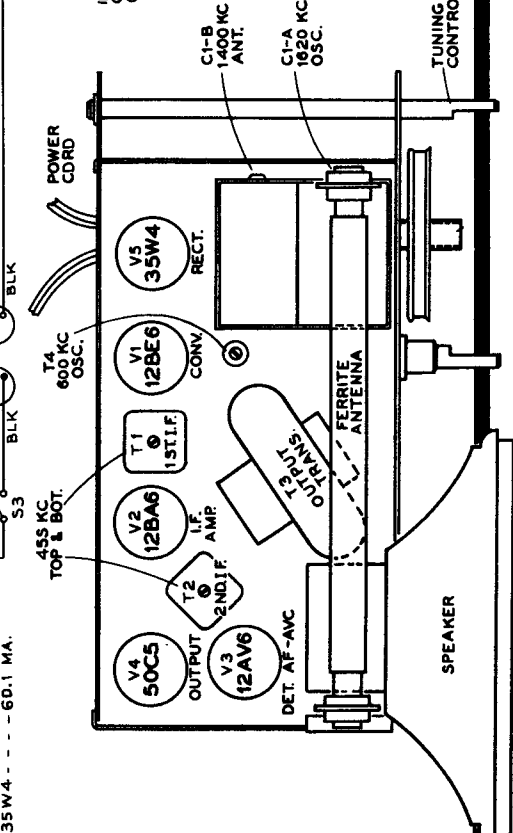

1955 MOST-OFTEN-NEEDED RADIO DIAGRAMS

RCA VICTOR MODEL 5-BX-41 Chassis No. RC-1147

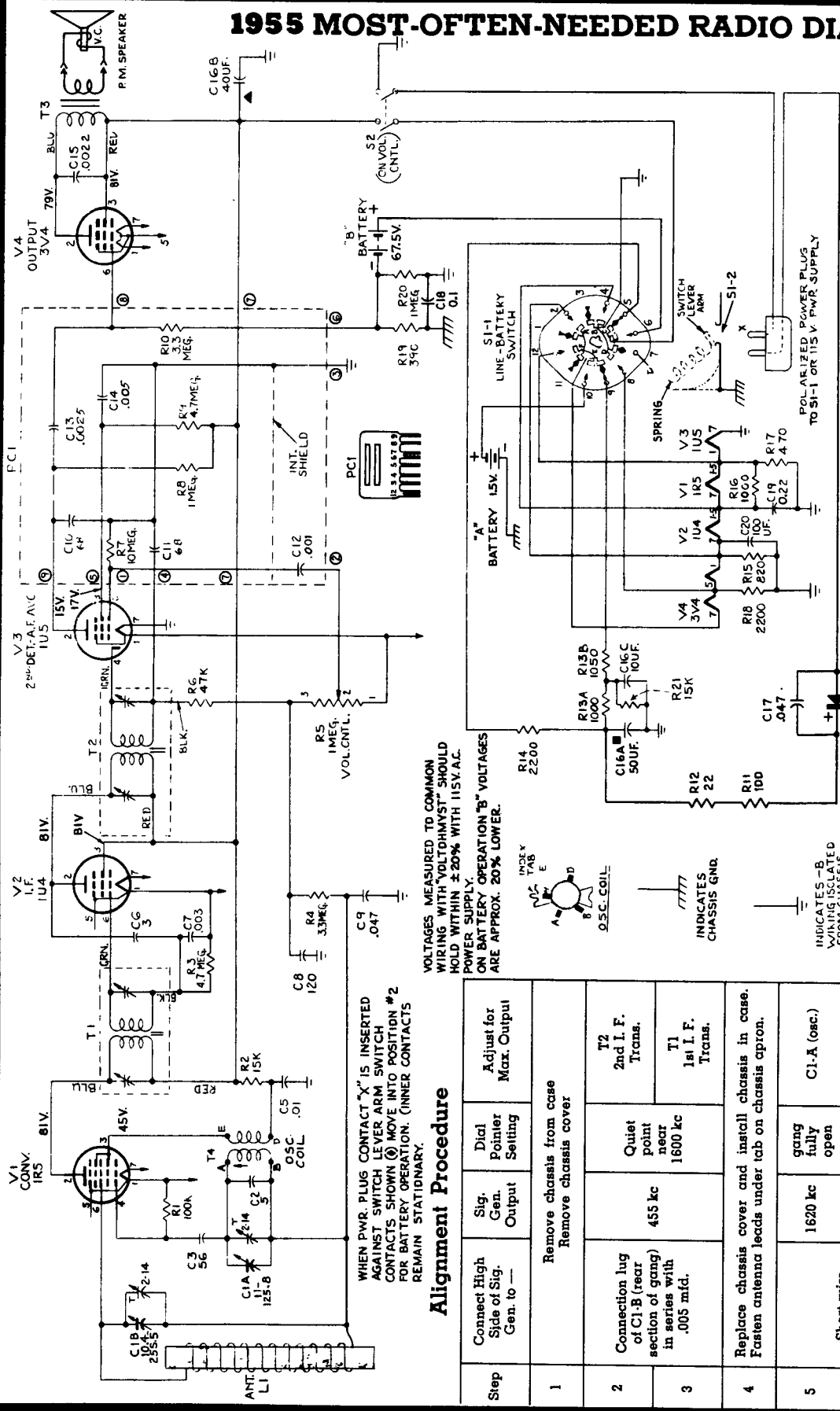

VOLTAGES MEASURED TO COMMON WIRING WITH "VOLTHMVST" SHOULD HOLD WITHIN $\pm 20\%$ WITH 115V.A.C. POWER SUPPLY.
ON BATTERY OPERATION "B" VOLTAGES ARE APPROX. 20% LOWER.

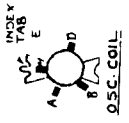

INDICATES CHASSIS GND.

INDICATES -B WIRING ISOLATED FROM CHASSIS.

WHEN PWR. PLUS CONTACT "X" IS INSERTED AGAINST SWITCH LEVER ARM, SWITCH CONTACTS SHOWN \odot MOVE INTO POSITION #2 FOR BATTERY OPERATION. (INNER CONTACTS REMAIN STATIONARY.)

Alignment Procedure

Step	Connect High Side of Sig. Gen. to —	Sig. Gen. Output	Dial Pointer Setting	Adjust for Max. Output
1	Remove chassis from case Remove chassis cover			
2	Connection lug of C1-B (rear section of gang) in series with .005 mid.	455 kc	Quiet point near 1600 kc	T2 2nd I. F. Trans. T1 1st I. F. Trans.
3	Repeat chassis cover and install chassis in case. Fasten antenna leads under tab on chassis apron.			
5	Short wire placed near antenna for radiated signal	1620 kc	gang fully open	C1-A (osc.)
6		1420 kc	1400 kc signal	C1-B (ant.)
7		600 kc	600 kc signal	T4 (osc.) rock gang
8	Repeat steps 5, 6 and 7.			

6 POLE -2 POSITION SWITCH S1-1 SHOWN FROM TERM. END WITH SWITCH SHAFT IN C/CLOCKWISE POSITION #1. (115V. OPERATION)
POSITION 1
FUNCTION 115V. AC-DC OPERATION BATTERY OPERATION.

MANUAL OF 1955 MOST-OFTEN-NEEDED RADIO DIAGRAMS



RCA VICTOR

MODEL 5-C-581

Chassis No. RC-1148A

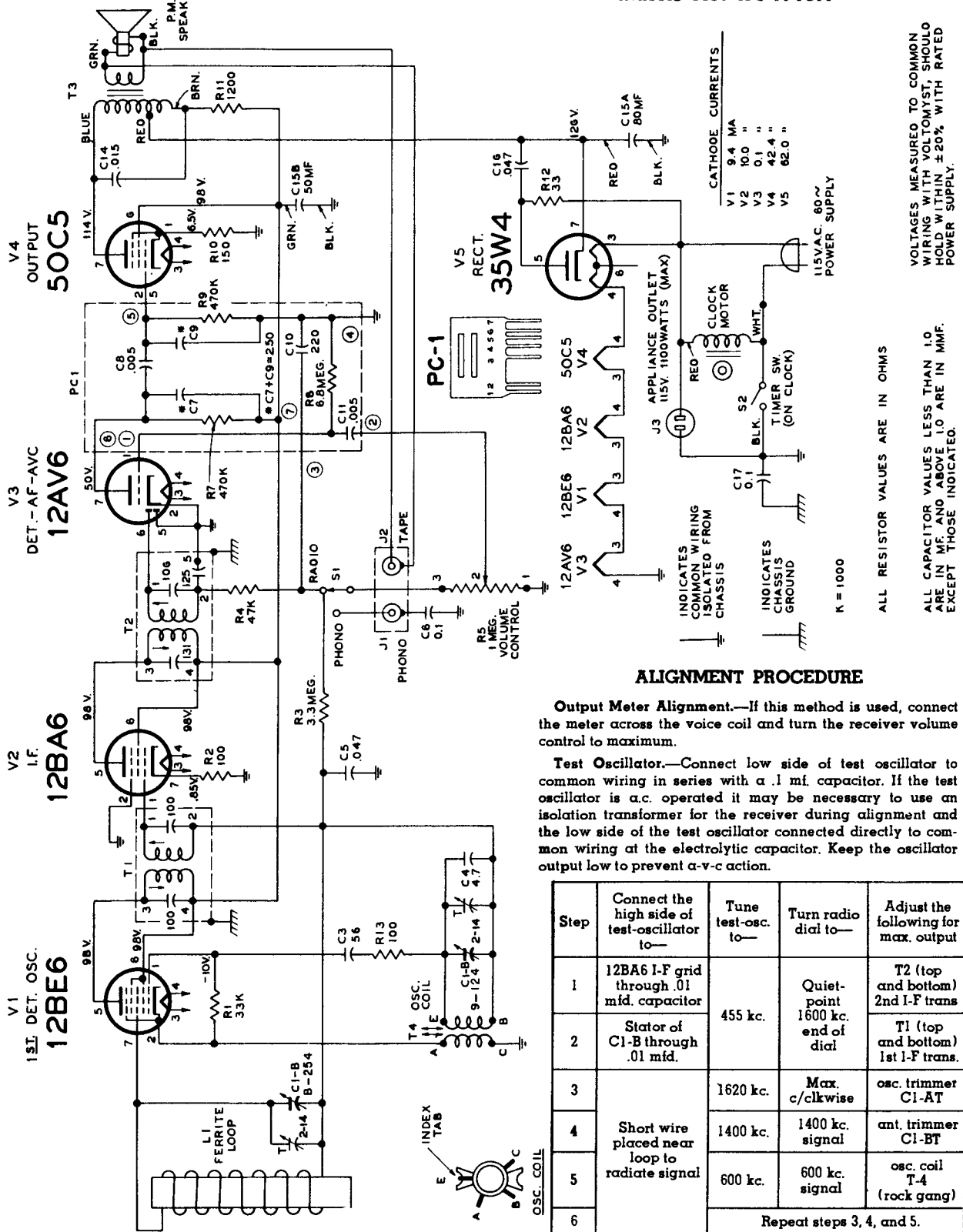

ALIGNMENT PROCEDURE

Output Meter Alignment.—If this method is used, connect the meter across the voice coil and turn the receiver volume control to maximum.

Test Oscillator.—Connect low side of test oscillator to common wiring in series with a .1 mf. capacitor. If the test oscillator is a.c. operated it may be necessary to use an isolation transformer for the receiver during alignment and the low side of the test oscillator connected directly to common wiring at the electrolytic capacitor. Keep the oscillator output low to prevent a-v-c action.

Step	Connect the high side of test-oscillator to—	Tune test-osc. to—	Turn radio dial to—	Adjust the following for max. output
1	12BA6 I-F grid through .01 mfd. capacitor	455 kc.	Quiet-point 1600 kc. end of dial	T2 (top and bottom) 2nd I-F trans
2	Stator of C1-B through .01 mfd.			T1 (top and bottom) 1st I-F trans.
3	Short wire placed near loop to radiate signal	1620 kc.	Max. c/clockwise	osc. trimmer C1-AT
4		1400 kc.	1400 kc. signal	ant. trimmer C1-BT
5		600 kc.	600 kc. signal	osc. coil T-4 (rock gang)
6	Repeat steps 3, 4, and 5.			

MANUAL OF 1955 MOST-OFTEN-NEEDED RADIO DIAGRAMS

RCA VICTOR

MODELS 5-C-591, 5-C-592

Chassis No. RC-1148

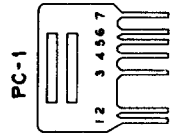
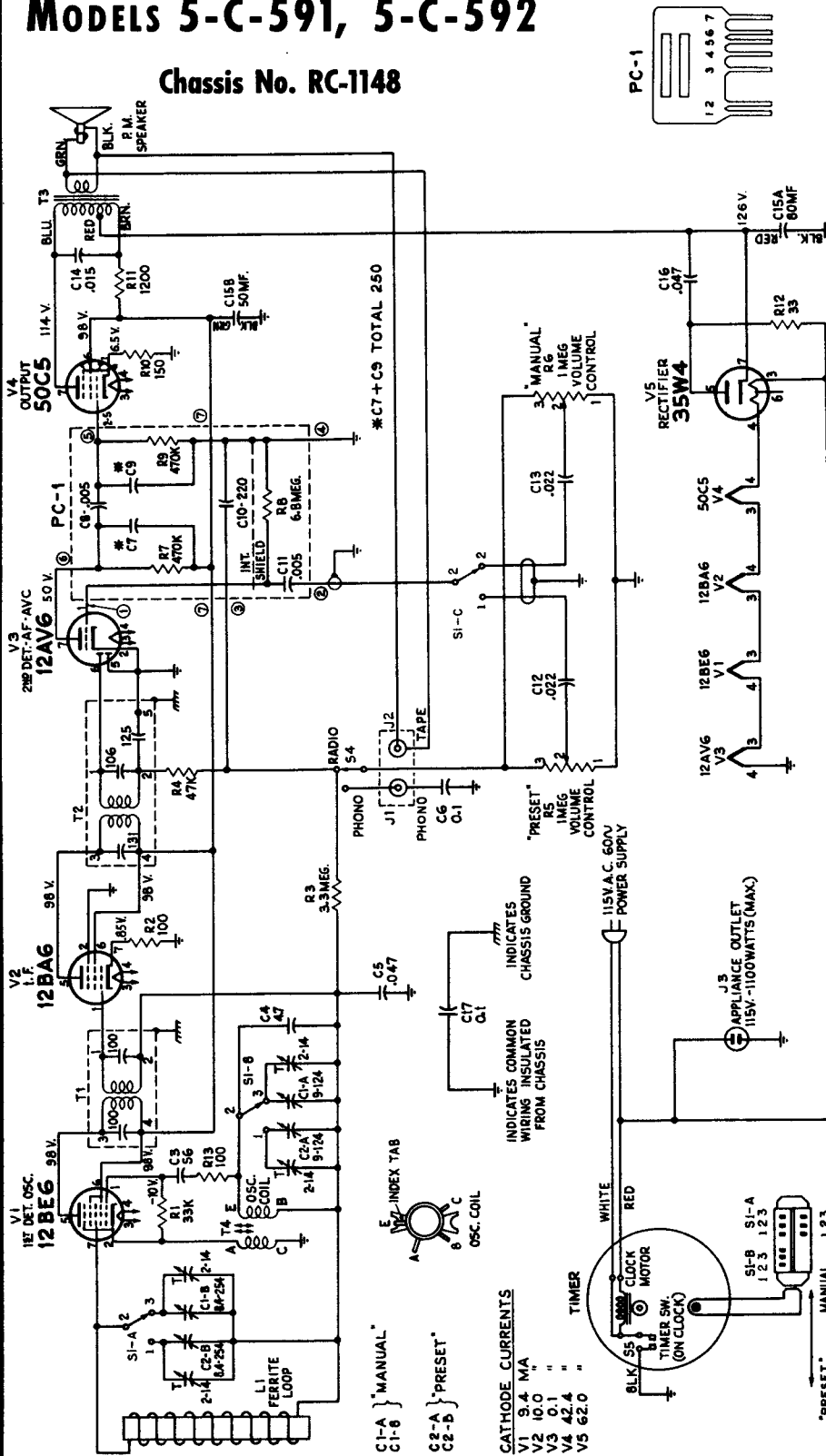

The clock is a new RCA developed timing unit, basically different from previous design. In addition to the conventional "automatic" wake-up features, a "preset" position is provided. With this "preset" feature it is possible to have the clock turn on the radio at a predetermined time to a different station and with a different volume level than when the radio was turned off (either manually or by "sleep" feature of the clock). A second important feature of the new timing unit is the simplification of the controls; the large clear polystyrene clock crystal has a knurled raised rim which can be set by rotation to four positions: "OFF," "ON," "AUTO," and "PRE-SET." A molded knob at the cabinet top can be pulled out for alarm buzzer sounding or pushed down for buzzer silencing; the same knob can be rotated for setting the "sleep" timing. Sleep time setting is indicated in a small window at the upper clock dial marked in 15 minute intervals up to one hour.

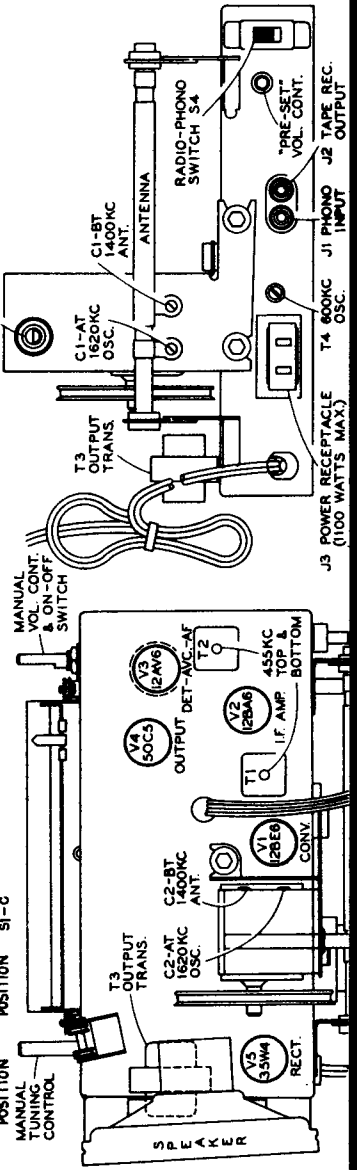

CATHODE CURRENTS

V1	9.4 MA
V2	10.0 "
V3	0.1 "
V4	42.4 "
V5	62.0 "

MANUAL OF 1955 MOST-OFTEN-NEEDED RADIO DIAGRAMS

AM-FM Radio Receiver MODEL 6-RF-9 Chassis No. RC1129A

(Alignment information and service data continued on the next two pages.)

RCA VICTOR

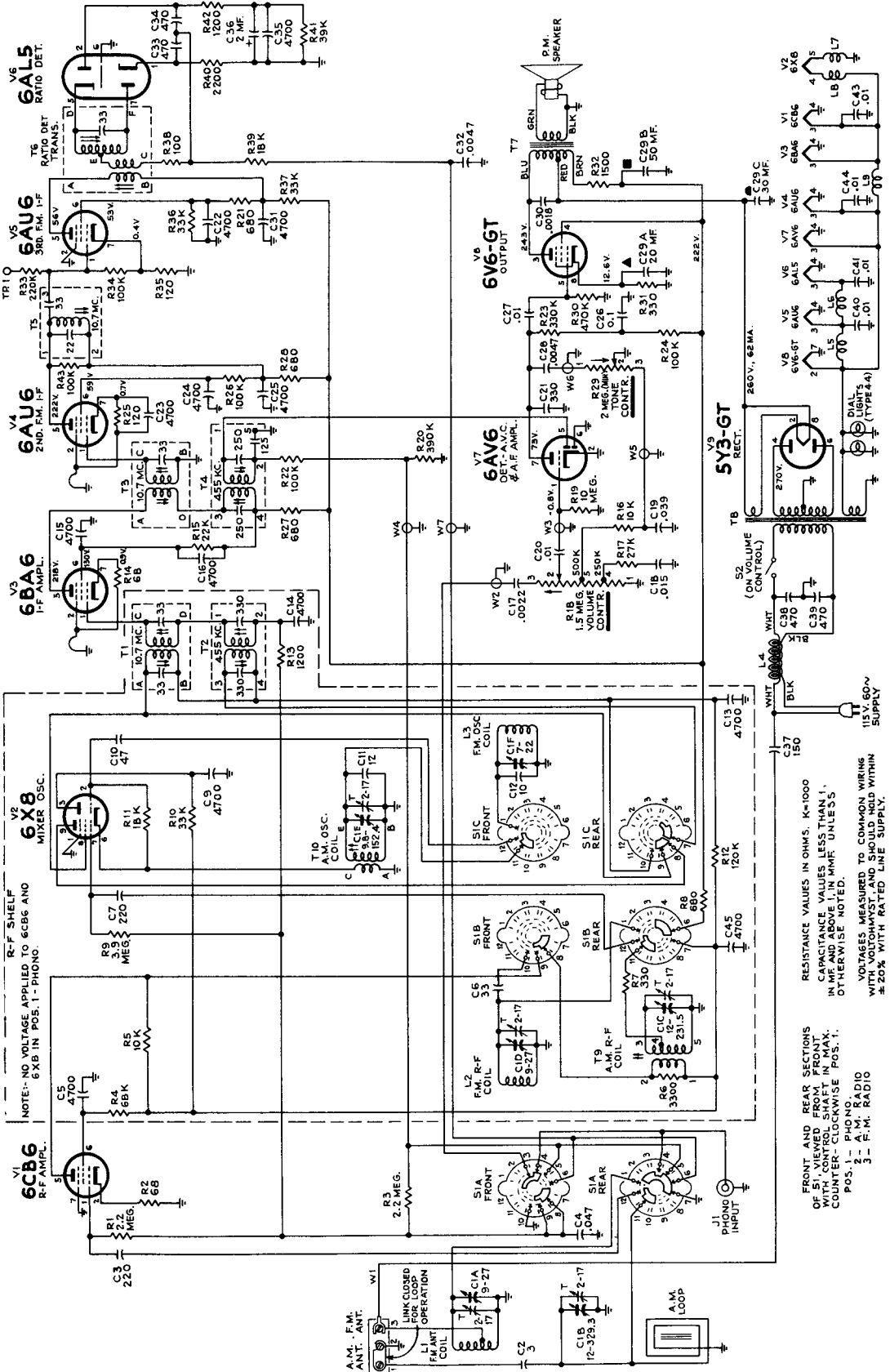

MANUAL OF 1955 MOST-OFTEN-NEEDED RADIO DIAGRAMS

RCA Victor Model 6-RF-9, Chassis RC-1129A (Continued)

(See also next page)

CORE PEAKING

Incorrect peaking can seriously affect gain and bandwidth. The correct peak is noted for the various coils and transformers.

1. The RF transformer core screw should be adjusted on the peak position furthest removed from the coil mounting clip. An incorrect peak may sometimes be obtained with the core screw almost all the way into the clip.
2. The oscillator coil (AM) should be adjusted on the peak obtained with the core coming out the lug end of the coil. When adjusting from the top of the chassis, this is the peak with the core furthest into the coil.
3. The position of the FM IF transformer screws should be noted after adjustment. These cores should be peaked with the core part way out of the coil toward the adjusting hole. It is possible to run the IF cores all the way through the FM windings and obtain a second peak. This will cause serious overcoupling and should be avoided by using a marked adjusting stick. The correct peak is always the first peak obtained when the core is started in from the "backed all the way out" position.

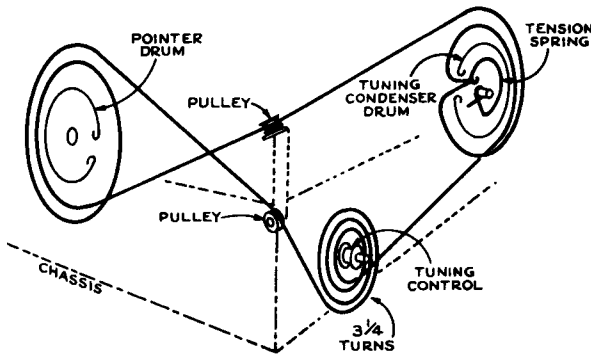

Dial Cord and Drive Assembly

VOLTAGE CHART

Tube	Type	Elements	Pin No.	"AM"	"FM"	Phono.
1	RF amp. 6CB6	Plate	5	195	128	—
		Screen	6	96	65	—
		Cathode Grid	1	0.4 -1.4	0.5 -0.2	—
2	Mixer 6X8	Plate	9	39	38	—
		Screen	8	39	39	—
		Grid	7	-2.8	-1.5	—
	Osc. 6X8	Plate	3	79	66	—
		Grid	2	-6.1	-2.3	—
3	IF amp. 6BA6	Plate	5	195	187	218
		Screen	6	122	100	130
		Cathode	7	0.8	0.9	0.9
		Grid	1	-1.6	—	-1.2
4	IF amp. 6AU6	Plate	5	200	195	222
		Screen	6	65	62	69
		Cathode	7	0.55	0.55	0.65
5	IF amp. 6AU6	Plate	5	52	50	56
		Screen	6	49	47	53
		Cathode	7	0.36	0.35	0.4
		Grid	1	-0.34	-0.34	-0.3
6	Ratio Det. 6AL5	—	—	—	—	—
7	AF amp. 6AV6	Plate	7	69	69	73
		Grid	1	-0.8	-0.8	-0.8
8	Output 6V6GT	Plate	3	242	240	243
		Screen	4	200	195	222
		Cathode	8	11.1	10.7	12.8
9	Rectifier 5Y3GT	Fil.	8	257	254	260

The heater voltage of the mixer/oscillator tube (6X8) is approx. 0.4 volt lower than other tubes in the same circuit. This is due to the filament choke coils L7 and L8.

Voltages and currents measured with tuning condenser closed and no signal input should hold within $\pm 20\%$ with rated line voltage.

RCA VoltOhmyst used for measuring all voltages.

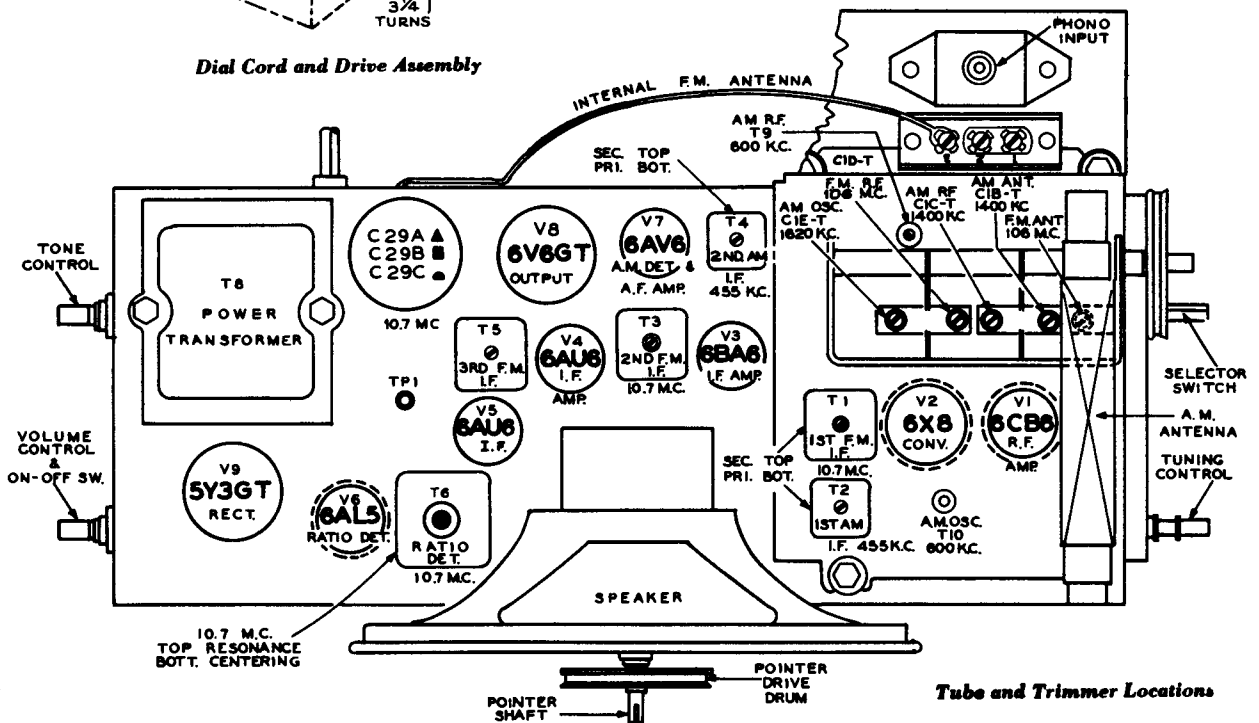

Tube and Trimmer Locations

MANUAL OF 1955 MOST-OFTEN-NEEDED RADIO DIAGRAMS

RCA Victor Model 6-RF-9, Chassis RC-1129A (Continued)

ALIGNMENT PROCEDURE

Due to the use of separate I.F. transformers, there is little interaction between the 10.7 mc. and the 455 kc. adjustments.

There is a slight interaction of adjustments on the tuning condenser between AM and FM.

Final adjustment of AM ant. trimmer should be made with chassis and antenna in cabinet.

Alignment Indicators:

For measuring the developed d-c voltage across C36 during FM alignment an RCA VoltOhmyst or an equivalent meter should be used. An output meter connected across the voice coil is also needed to indicate minimum audio output during FM Ratio Detector alignment.

The RCA VoltOhmyst can also be used to indicate audio output voltage across the voice coil or developed voltage on the AVC bus.

Signal Generator:

For alignment operations connect the low side of the signal generator to the receiver chassis. The output of the signal generator should always be controlled to prevent over-loading or excessive AVC action.

Oscilloscope Alignment:

It is preferable to use a sweep generator and oscilloscope for aligning I.F. and R.F. circuits to obtain a visual observation of curve shape during alignment.

With FM sweep generator connected between FM ant. (#3) terminal and chassis, and oscilloscope connected between the junction of R39-C32 and chassis, the overall FM linearity may be observed. With 100% FM modulation there should be a peak-to-peak separation of 150 kc. with 50,000 microvolts input before noticeable distortion of the sine wave is present.

For FM alignment of the ratio detector, connect oscilloscope to junction of 56K resistors as in alignment table, adjusting T6 top and bottom cores for 10.7 mc. crossover and balanced peaks. When aligning other FM tuned circuits, connect oscilloscope to TPI. Follow alignment table sequence, adjusting for maximum gain and symmetry.

AM Alignment

RANGE SWITCH IN AM POSITION

Steps	Connect high side of sig. gen. to—	Sig. gen. output	Turn radio dial to—	Adjust for peak output	
1	Pin 1 of V3 6BA6 in series with .01 mfd.	455 kc.	Quiet point at low freq. end	T4 bottom core (pri.) T4 top core (sec.)	
2	Tap terminal T9 term. 4 in series with .01 mfd.			T2 top core (sec.) T2 bottom core (pri.)	
3	No. 1 terminal on ant. input strip	1620 kc.	High freq. end of dial (min. cap.)	C1E-T	
4		1400 kc.	1400 kc. signal	C1B-T ant. C1C-T r.f.	
5		Shunt a 10,000 ohm resistor across the r.f. section of the gang.			
6		600 kc.	600 kc. signal	T10 osc.* (Rock gang.)	
7		Remove the 10,000 ohm resistor and peak T9 r.f.*			
8		Repeat 3, 4, 5, 6 and 7			

* The correct adjustment of the Osc. (T10) core is that peak obtained with core furthest away from the coil mounting clips. R.F. (T9) core should be set to the peak obtained (2 peaks are seldom obtainable) with core closest to the mounting clips.

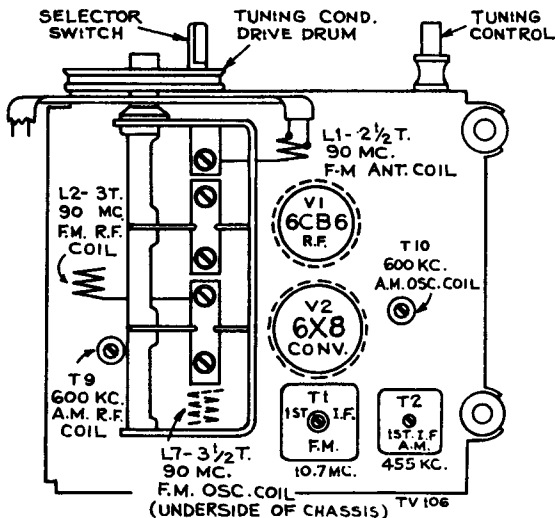

FM Coil Locations

FM Alignment

RANGE SWITCH IN FM POSITION— VOLUME CONTROL MAXIMUM—TONE CONTROL CENTER

Steps	Connect high side of sig. gen. to—	Sig. gen. output	Turn radio dial to—	Adjust for peak output
1	Pin 1 of V5 6AU6 in series with .01 mfd.	10.7 mc. modulated 30% 400 cycles	Quiet point at low freq. end	
2	Connect VoltOhmyst across R41-39K resistor. Adjust Sig. gen. output to give 1 volt d-c on VoltOhmyst.			T6 top core for max. d-c voltage across C36
3	Shunt R41 with two 56K ±1% resistors connected in series. Connect VoltOhmyst from center junction of 56K resistors to junction of R39 and C32.			T6 bottom core for 0 volts d-c
4	Pin 1 of V3 6BA6 in series with .01 mfd.	10.7 mc. modulated 30% 400 cycles	Quiet point at low freq. end	VoltOhmyst conn. to TPI. ††T5 top core. T3 top & bottom cores.
5	Stator of C1D in series with .01 mfd.			
6	FM Ant. terminals 270 ohm resistor in series #3 term.	90 mc.	90 mc.	Remove bottom shield **Osc. coil L3
7		106 mc.	106 mc. signal	Replace bottom shield. C1A-T ant., C1D-T r.f.
8		90 mc.	90 mc.	**L1 ant. L2 r.f.
9	Repeat steps 6, 7, and 8 until further adjustment does not improve calibration.			

†† Alternate loading may be necessary to provide accurate observation of peaks.

Alternate loading involves the use of a 680 ohm resistor to load the plate winding while the grid winding of the SAME TRANSFORMER is being peaked. Then the grid winding is loaded with the resistor while the plate winding is peaked. Only one winding is loaded at any one time. Remove the 680 ohm resistor after T3 and T1 have been aligned.

Oscillator frequency is above signal frequency on both AM and FM.

Extreme care should be used to avoid running the I.F. cores all the way through the winding and out the other end.

** Note: FM antenna, mixer and oscillator coils are adjustable by increasing or decreasing the spacing between turns. The location of the tap on the antenna coil is 1/2 turn to 3/4 turn from the ground end.

MANUAL OF 1955 MOST-OFTEN-NEEDED RADIO DIAGRAMS



RCA VICTOR

AM-FM Radio Receiver

MODEL 6-XF-9

Chassis No. RC-1121B

ALIGNMENT INDICATORS:

An RCA VoltOhmyst or equivalent meter is necessary for measuring developed d-c voltage during FM alignment. Connections are specified in the alignment tabulation. An output meter is also necessary to indicate maximum audio output during AM alignment. Connect the output meter across the speaker voice coil. The RCA VoltOhmyst can also be used as an AM alignment indicator, either to measure audio output or to measure AVC voltage. When audio output is being measured, the volume control should be turned to maximum. Adjust tone control to mid-position.

SIGNAL GENERATOR:

For all alignment operations, connect the low side of the signal generator to the receiver chassis. If output measurement is used for AM alignment, the output of the signal generator should be kept as low as possible to avoid AVC action.

(See next page at right for circuit diagram and additional material.)

If an FM sweep generator is used for FM alignment, adjust for 10.7 mc, 0.4 mc sweep. Connect oscilloscope across C26, adjusting discriminator T6 top core for 10.7 mc crossover, and T6 bottom core for balanced peaks. Peak separation should be approximately 330 kc. When aligning the other FM tuned circuits, connect oscilloscope lead through a 220K resistor to pin 1 of V5. Follow alignment table sequence, adjusting for maximum gain and symmetrical curves.

TUNING RANGE

Standard Broadcast (AM) 540-1600 kc
 Frequency Modulation (FM) 88-108 mc
 Intermediate Frequency (AM) 455 kc
 Intermediate Frequency (FM) 10.7 mc

AM Alignment

FUNCTION SWITCH IN AM POSITION

Steps	Connect high side of sig. gen. to—	Sig. gen. output	Turn radio dial to—	Adjust for peak output
1	Pin No. 1 of V3 in series with .01 mfd	455 kc. (mod.)	Quiet point at high freq. end	T4 bottom core (sec.) T4 top core (pri.)
2	Tap lug 4 on AM RF coil			T2 bottom core (sec.) T2 top core (pri.)
3	Short wire placed near loop for radiated signal	1620 kc. (mod.)	1620 kc. (gang open)	C1E-T (osc.)
4		1400 kc. (mod.)	1400 kc.	C37 (ant.) C1C-T (rf.)
5		600 kc. (mod.)	600 kc.	L6 (osc.) with (locking gang)
6				L4 (RF)
7	Repeat steps 4, 5 and 6 until Maximum gain is obtained			

FM Alignment

FUNCTION SWITCH IN FM POSITION—VOLUME CONTROL MINIMUM—TONE CONTROL CENTER

Steps	Connect high side of sig. gen. to—	Sig. gen. output	Turn radio dial to—	Adjust for max. output	
1	Pin No. 1 of V5-12AU6	10.7 mc	Quiet point at low frequency end	T6 top core for zero d.c. (across C26) T6 bottom core for maximum d.c. (junction of R24 and R25)	
2	Pin No. 1 of V4-12AU6			†T5 top core	
3	Pin No. 1 of V3-12BA6			T3 top core †T3 bottom core	
4	C1-B Stator			T1 top core †T1 bottom core	
5	FM Ant. terminals thru 270 ohm resistor	87 mc.	87 mc. (gang closed)	†FM osc. L8	
6		106 mc.	106 mc.	†FM RF C1B-T	
7		90 mc.	90 mc.	†FM R.F. L2	
8		Repeat steps 6 and 7 until maximum gain is obtained			
9		100 mc.	100 mc.	†FM Ant. coil L5	

*If necessary for accurate peaking, the winding in the same transformer not being peaked should be loaded with a 680 ohm resistor.
 †Connect VoltOhmyst to pin 1 of V5 through a 220K isolating resistor with ¼ inch maximum exposed lead at grid terminal end. Output adjusted for 1 volt d.c. Dress VoltOhmyst lead away from input circuits.

Oscillator frequency is above signal frequency on both AM and FM

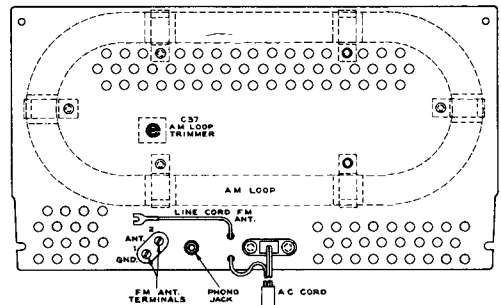

Rear View

CRITICAL LEAD DRESS

- All FM IF Transformer grid and plate leads should be short and direct as possible and kept low, near chassis.
- C26 leads should be kept as short as possible.
- C32 leads should be kept as short as possible.
- R24 and R25 leads should be kept as short as possible on T6 terminal 6 side.
- C27 should ground in hole near terminal 5 of V6 with short leads.
- AM oscillator coil should not be tilted over toward function switch when wrapping short bus leads to switch.
- Keep leads V5 pin 5, to T6 term 1, as short as possible and low near chassis.
- Dress C28 down on chassis and against terminal board. Run filament lead between V5 and V6 on side of V6 socket opposite C28.
- All ceramic button 4700 uuf condensers should have leads as short as possible.
- Green lead from AM oscillator stator gang terminal to AM oscillator coil should be dressed against front of shield box and up above filament choke.
- RF plate choke L1, should be dressed at least ¼" away from AM R.F. coil L4 and at least ¼" from shield.
- Mixer grid condenser C7 should be dressed away from FM oscillator gang stator terminal and away from leads connecting to terminals 8 and 9 of V2 socket.
- Filament chokes L10 and L11 should be raised a minimum of 1/16" above chassis.
- Use varnished tubing only on choke and coupling cond. leads coming through shield partition slot.
- Condenser C2 should have lead on antenna terminal end not more than 3/16" long to prevent possible contact of lead or body to "Hot" chassis.
- Condensers C3 and C35 should use varnished tubing, not vinyl, to prevent breakthrough crossing chassis edge.
- Oscillator grid condenser C17 should have short leads and be dressed away from filament choke L10.
- Leads from loop terminal to chassis terminal board should have a minimum of three twists (otherwise loop increases oscillator radiation).

MANUAL OF 1955 MOST-OFTEN-NEEDED RADIO DIAGRAMS

AC-DC-Battery Portable Receiver



RCA Models 6-BX-5, 6-BX-6 Series

Chassis No. RC-1149

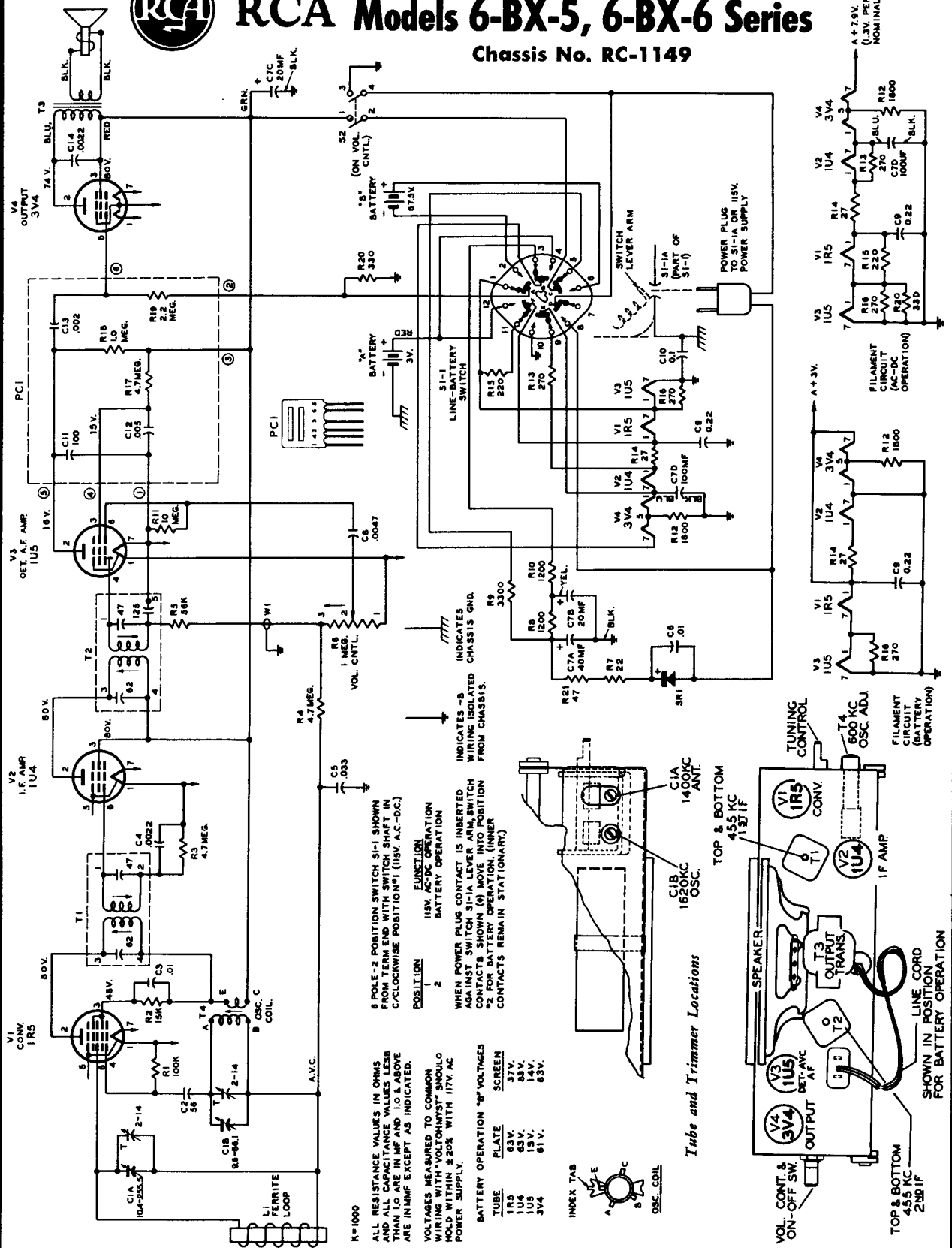

6 POLE-2 POSITION SWITCH S1-1 SHOWN FROM TERM END WITH SWITCH SHAFT IN C/CLOCKWISE POSITION (1) (15V. A.C.-D.C.)

FUNCTION
 1 15V. A.C.-D.C. OPERATION
 2 BATTERY OPERATION

WHEN POWER PLUG CONTACT IS INSERTED AGAINST SWITCH S1-1A LEVER ARM, SWITCH CONTACTS SHOWN (1) MOVE INTO POSITION FROM CHASSIS. CONTACTS REMAIN STATIONARY.

N° 1000

ALL RESISTANCE VALUES IN OHMS AND ALL CAPACITANCE VALUES LESS THAN 10 ARE IN MF AND 1.0 & ABOVE ARE IN MMF EXCEPT AS INDICATED.

VOLTAGES MEASURED TO COMMON WIRING WITH "VOLTOHMIST" SHOULD HOLD WITHIN ±20% WITH 117V. AC POWER SUPPLY.

BATTERY OPERATION "B" VOLTAGES

TUBE	PLATE	SCREEN
1R5	63V.	37V.
1U4	63V.	63V.
1U5	15V.	14V.
3V4	61V.	63V.

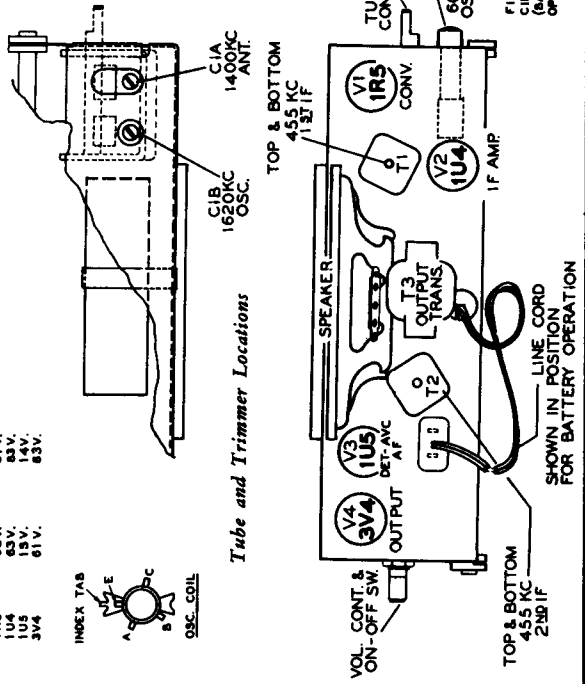

Tube and Trimmer Locations

MANUAL OF 1955 MOST-OFTEN-NEEDED RADIO DIAGRAMS

SEARS, ROEBUCK and Co.

Model Numbers 5036 and 5042,
Chassis No. 528.32400 and 528.32500

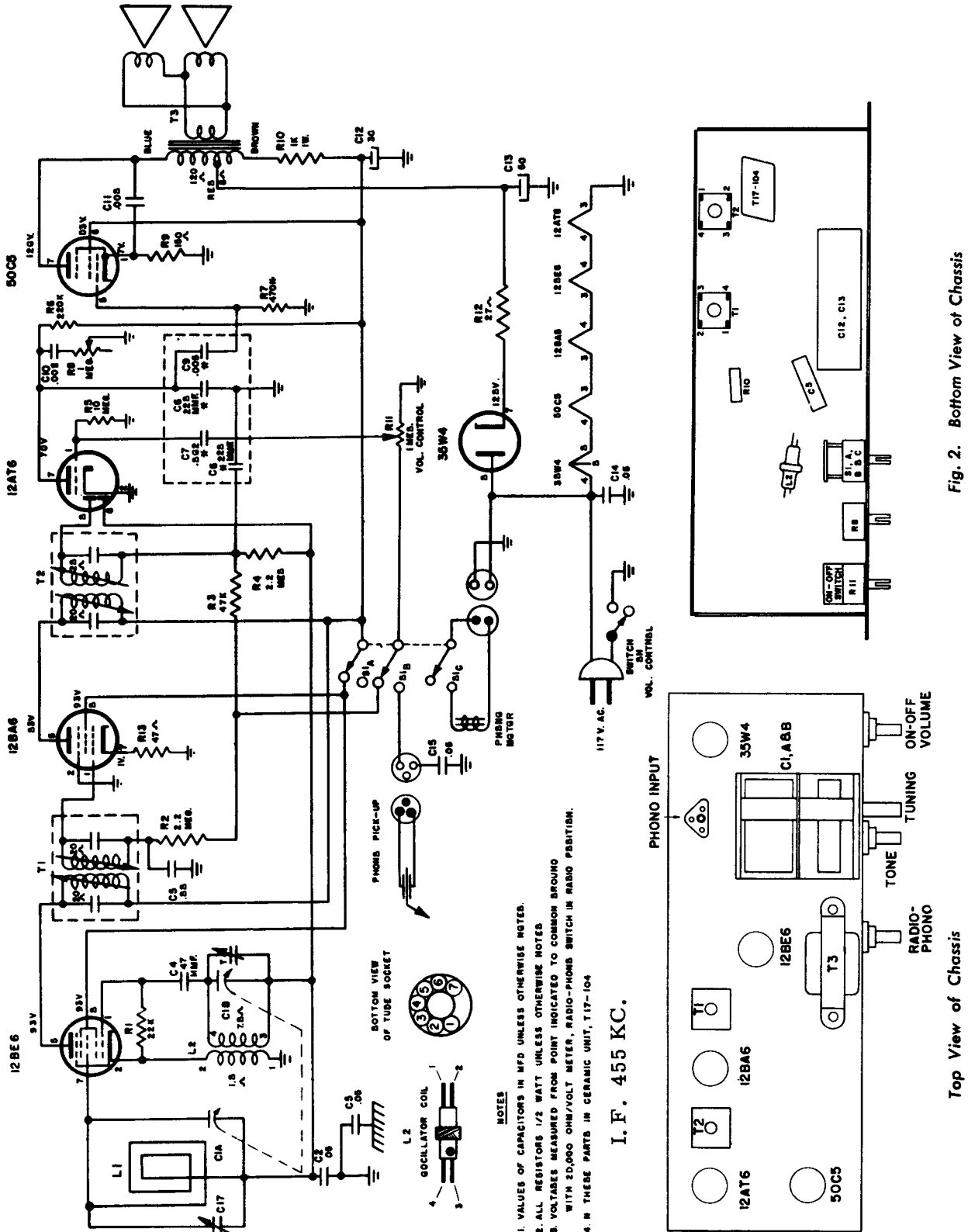

Fig. 2. Bottom View of Chassis

Top View of Chassis

MANUAL OF 1955 MOST-OFTEN-NEEDED RADIO DIAGRAMS

SEARS, ROEBUCK and Co.

Models 5045, 5046, Chassis No. 528.34900

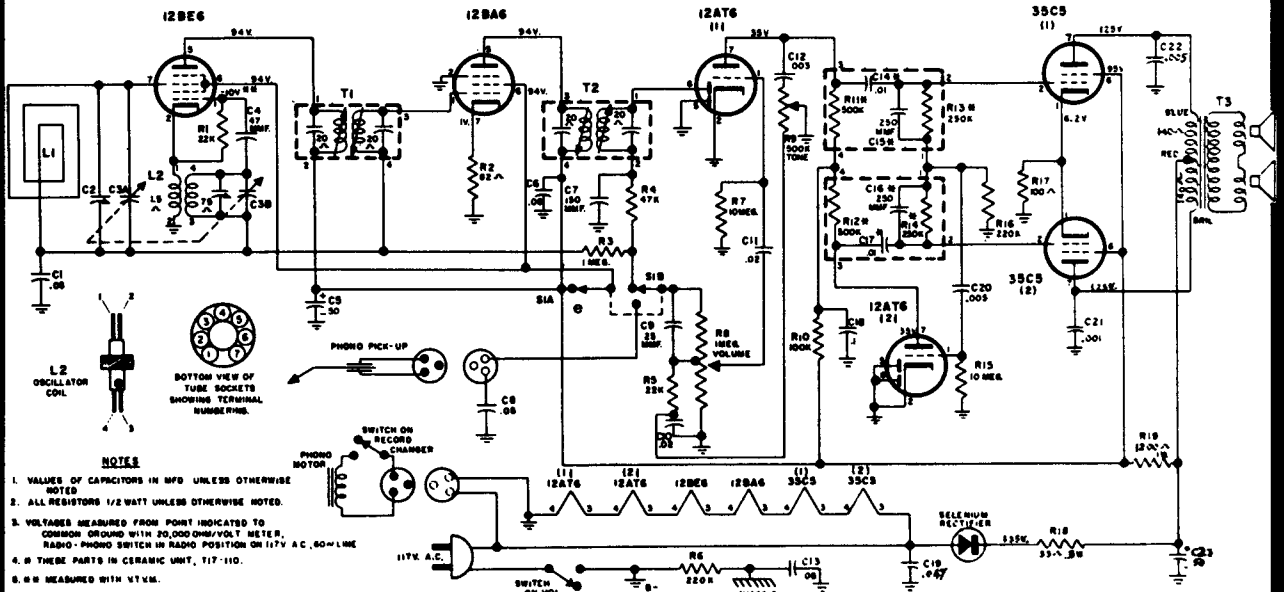

- NOTES**
1. VALUES OF CAPACITORS IN MFD UNLESS OTHERWISE NOTED.
 2. ALL RESISTORS 1/2 WATT UNLESS OTHERWISE NOTED.
 3. VOLTAGES MEASURED FROM POINT INDICATED TO COMMON GROUND WITH 20,000 OHM/VOLT METER. RADIO-PHONO SWITCH IN RADIO POSITION ON 117V A.C. 60-HZ LINE.
 4. S THESE PARTS IN CERAMIC UNIT, T17-110.
 5. R.H. MEASURED WITH VTVM.

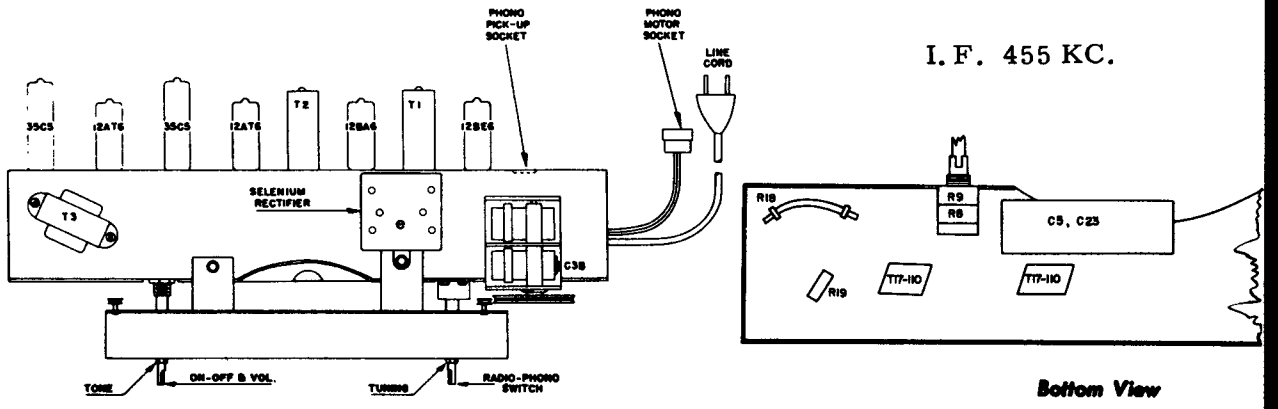

I. F. 455 KC.

Top View of Chassis

Bottom View

CHASSIS PARTS LIST

SCHEMATIC LOCATION	PART NUMBER	DESCRIPTION
C1, C6	T16-197	Capacitor, tubular; .05 mfd., 200 v.
C2	T20-143	Capacitor, antenna trimmer
C3, A & B	T19-231	Capacitor, variable; with drum
C4	T15-229	Capacitor, ceramic; 47 mmfd.
C5, C23	T18-304	Capacitor, elec., 30-50 mfd., 150 v.
C7	T15-251	Capacitor, ceramic; 150 mmfd.
C8, C13	T16-189	Capacitor, tubular; .05 mfd., 400 v.
C9	T15-256	Capacitor, mica; 25 mmfd.
C10	T16-150	Capacitor, tubular; .02 mfd., 400 v.
C11	T15-240	Capacitor, ceramic; .02 mfd., 400 v.
C12	T16-200	Capacitor, tubular; .003 mfd., 600 v.
C14, C15, C16, C17		Parts of ceramic coupling units (T17-110)
C18	T16-203	Capacitor, tubular; .1 mfd., 200 v.
C19	T16-447	Capacitor, tubular; .047 mfd., 400 v.
C20	T16-177	Capacitor, ceramic; .005 mfd.
C21, C22	T16-254	Capacitor, tubular; .001 mfd., 600 v.
R1, R5	S602230M	Resistor, 22K ohm, 1/2 w.
R2	S608200K	Resistor, 82 ohm, 1/2 w., 10%
R3	S601050M	Resistor, 1 megohm, 1/2 w.
R4	S604730M	Resistor, 47K ohm, 1/2 w.
R6, R16	S602240M	Resistor, 220K ohm, 1/2 w.
R7, R15	S601060M	Resistor, 10 megohm, 1/2 w.
R8, R9	T24-224	Resistor, variable, dual; ON-OFF VOLUME (1 megohm) TONE (500K ohm)

SCHEMATIC LOCATION	PART NUMBER	DESCRIPTION
R10	S601040M	Resistor, 100K ohm, 1/2 w.
R11, R12, R13, R14		Parts of ceramic coupling units (T17-110)
R17	S601010K	Resistor, 100 ohm, 1/2 w., 10%
R18	T61-10	Resistor, 33 ohm, 3 w., 10%
R19	S601221K	Resistor, 1200 ohm, 1 w., 16%
L1	T82-72	Antenna
L2	T10-645	Coil, oscillator
T1	T10-500	Transformer, 1st I.F.
T2	T10-479	Transformer, 2nd I.F.
T3	T80-295	Transformer, Output
S1, A & B	T69-203	Switch, RADIO-PHONO
	T72-89	Bushing, dial card
	T17-110	Ceramic coupling unit (2)
	T21-203	Cover, Selenium Rectifier
	T23-151	Cord, Power Line, 6 Ft.
	T37-163	Insulator, Selenium Rectifier
	T58-111	Pointer
	T83-780	Selenium rectifier (100 MA)
	T68-43	Socket, 7 pin miniature
	T68-41	Socket, Phono pick up
	T22-142	Socket, Phono motor
	T70-135	Spring, dial cord tension
	T51-109	String, pointer drive

MANUAL OF 1955 MOST-OFTEN-NEEDED RADIO DIAGRAMS

SENTINEL RADIO CORPORATION

MODELS 353-1U-353

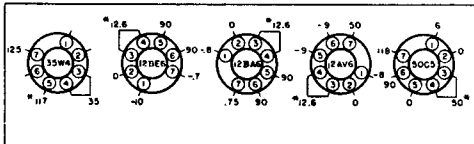
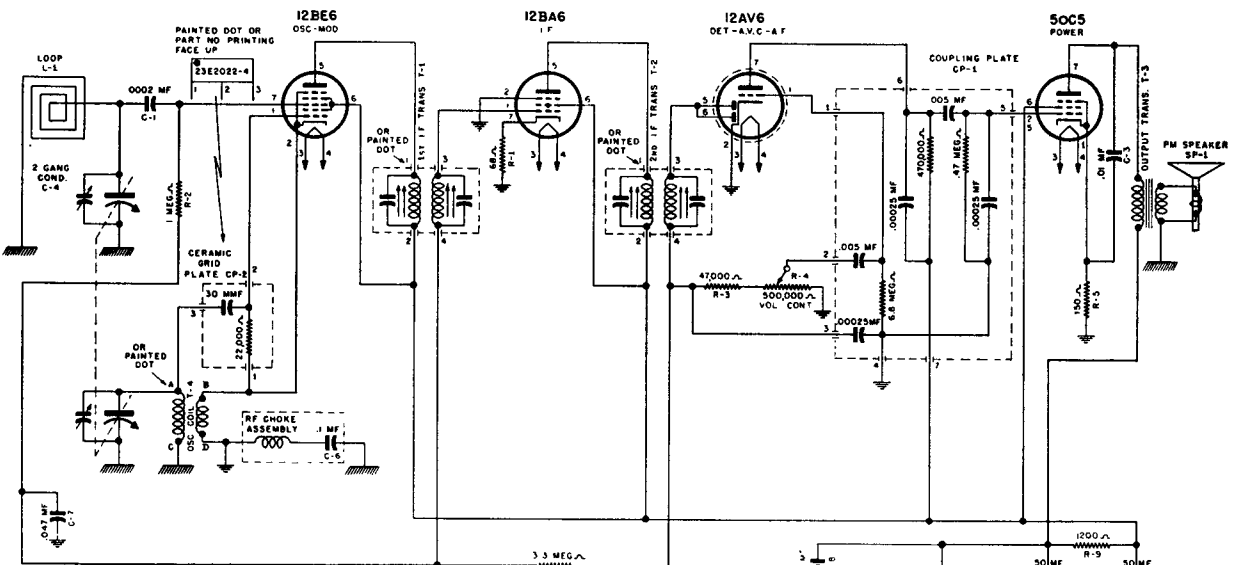

ALL VOLTAGES EXCEPT HEATERS ARE MEASURED FROM SOCKET CONTACTS TO THE COMMON NEGATIVE WITH A 1000 OHM PER VOLT VOLTMETER. HEATER VOLTAGES ARE MEASURED DIRECTLY ACROSS SOCKET CONTACTS.

= AC VOLTAGES

VOLTAGE TABLE
(BOTTOM VIEW OF CHASSIS)

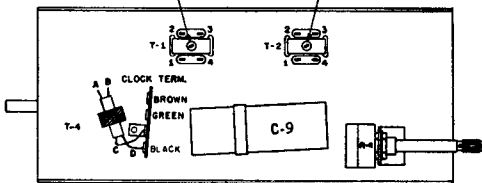

ALIGNMENT PROCEDURE

When aligning the 1620 KC OSCILLATOR TRIMMER or the 1400 KC ANTENNA TRIMMER, couple test oscillator to receiver loop by: (1) make loop consisting of five to ten turns of NO. 20 to NO. 30 size wire, wound on a 2" to 3" form; (2) connect this loop across output of test oscillator; (3) place test oscillator loop near radio loop.

Steps	Set receiver dial to:	TEST OSCILLATOR			Refer to parts layout diagram for location of trimmers mentioned below:
		Adjust test oscillator frequency to:	Use dummy antenna in series with output of test oscillator consisting of:	Attach output of test oscillator to:	
1	Any point where no interfering signal is received.	455 K.C.	.02 MFD. condenser	High side to antenna stator plates of tuning condenser. Low side to common negative.	Adjust each of the second I.F. transformer trimmers for maximum output—then adjust each of the first I.F. trimmers for maximum output.
2	Exactly 1620 K.C.	Exactly 1620 K.C.	See paragraph above.	See paragraph above.	Adjust 1620 K.C. oscillator trimmer for maximum output.
3	Approx. 1400 K.C.	Approx. 1400 K.C.	See paragraph above.	See paragraph above.	Adjust 1400 K.C. antenna trimmer for maximum output.

MANUAL OF 1955 MOST-OFTEN-NEEDED RADIO DIAGRAMS

STROMBERG-CARLSON

CLOCK RADIO RECEIVER—MODELS C-3 C-5

AC-DC Radio Receiver Model T-4 is electrically the same except that the clock circuit is omitted.

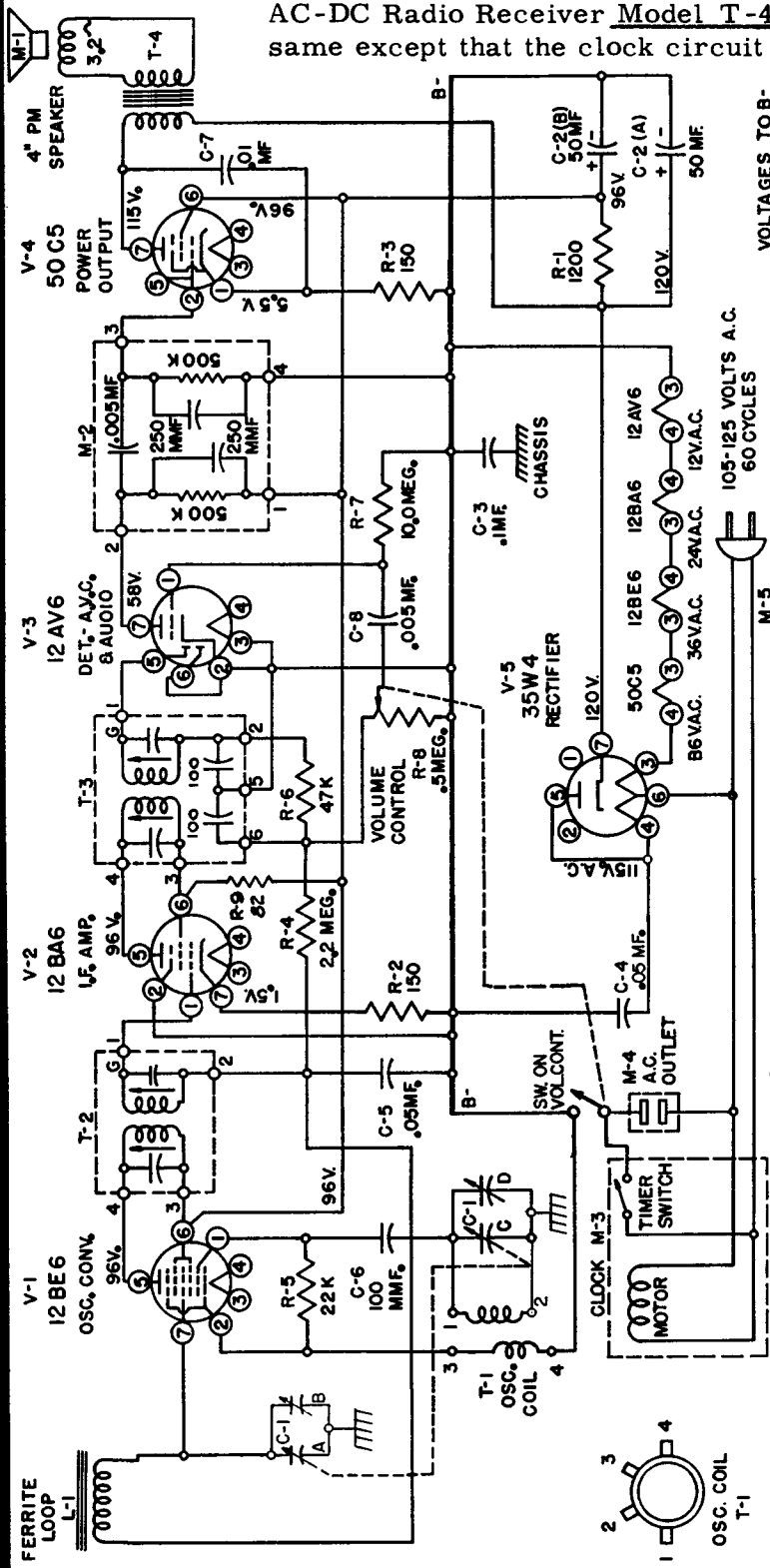

VOLTAGES TO BE MEASURED AT 117V. 60~ INPUT

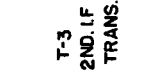
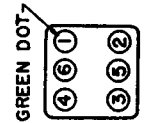
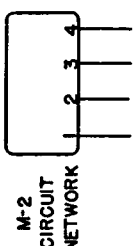

ALIGNMENT PROCEDURE

I.F. Alignment

Receiver volume control set at maximum. Output meter connected across speaker voice coil. Use modulated signal with output level from generator no higher than necessary to obtain indication on output meter. Use non-metallic alignment tool with light pressure on all slugs adjustments.

SIGNAL INPUT	FREQUENCY	DUMMY ANTENNA	TUNING CAPACITOR	ADJUSTMENTS	NOTES
Converter grid (pin 7 of V-1, 12BE6) or stator of C-1-A	455 KC (400 cycles modulation)	.1 mfd	Point of non-interference at mid frequency	Bottom and top slugs of T-2 and T-3	Adjust for maximum output.

R.F. Alignment

Rotate tuning condenser until fully unmeshed (min. capacity).

SIGNAL INPUT	FREQUENCY	DUMMY ANTENNA	TUNING CONDENSER	ADJUSTMENTS	NOTES
Converter grid (pin 7 of V-1, 12BE6) or stator of C-1-A	1625 KC	.1 mfd	Fully unmeshed (min. capacity)	Oscillator Trimmer C-1-D.	Adjust for maximum output.
Radiating loop	1400 KC		Tuned to 1400 KC	R.F. Trimmer C-1-B	Adjust for maximum output.

MANUAL OF 1955 MOST-OFTEN-NEEDED RADIO DIAGRAMS

Stromberg-Carlson

AC/DC Battery Operated Portable Radio Receiver—Model EP-2

VOLTAGE CHART

Voltage measurements made at 117 volt 60 cycle line using vacuum tube voltmeter.
Except where otherwise noted, all voltages are positive with respect to B—.

TUBE	FUNCTION	PIN NUMBER						
		1	2	3	4	5	6	7
V-1	1R5 Converter	1.37	72	42	—5.0	1.37	—0.1	2.75
V-2	1U4 I.F. Amp.	2.75	72	72	NC	2.75	1.5	4.3
V-3	1U5 Det. 1st audio	0	25	18	—0.2	NC	—0.05	1.37
V-4	3V5 Audio output	4.3	70	72	NC	5.8	0	7.2

ALIGNMENT PROCEDURE

I.F. Alignment

Receiver operation at 117 volt 60 cycle AC with volume control set at maximum. Output meter across speaker voice coil. Use modulated signal with output level from generator no higher than necessary to obtain indication on output meter. Return low side of signal generator to B—. Use non-metallic alignment tool with light pressure on all slug adjustments.

SIGNAL INPUT	FREQUENCY	DUMMY ANTENNA	TUNING CAPACITOR	ADJUSTMENTS	NOTES
Converter grid (pin #6 at 1R5) or stator of C-1A	455 KC (400 cycles modulation)	0.1 mfd	Point of non-interference at mid-frequency	Bottom and top slugs of T-3 and T-2	Adjust for maximum output

R.F. Alignment

Rotate tuning condenser until fully unmeshed (min. capacity).

SIGNAL INPUT	FREQUENCY	DUMMY ANTENNA	TUNING CAPACITOR	ADJUSTMENTS	NOTES
Converter grid (pin #6 at 1R5) or stator of C-1A	1625 KC	0.1 mfd	Fully unmeshed (min. capacity)	Oscillator trimmer C-1D	Adjust for maximum output
Radiating loop	1400 KC	—	—	R.F. Trimmer C-1B	Adjust for maximum output

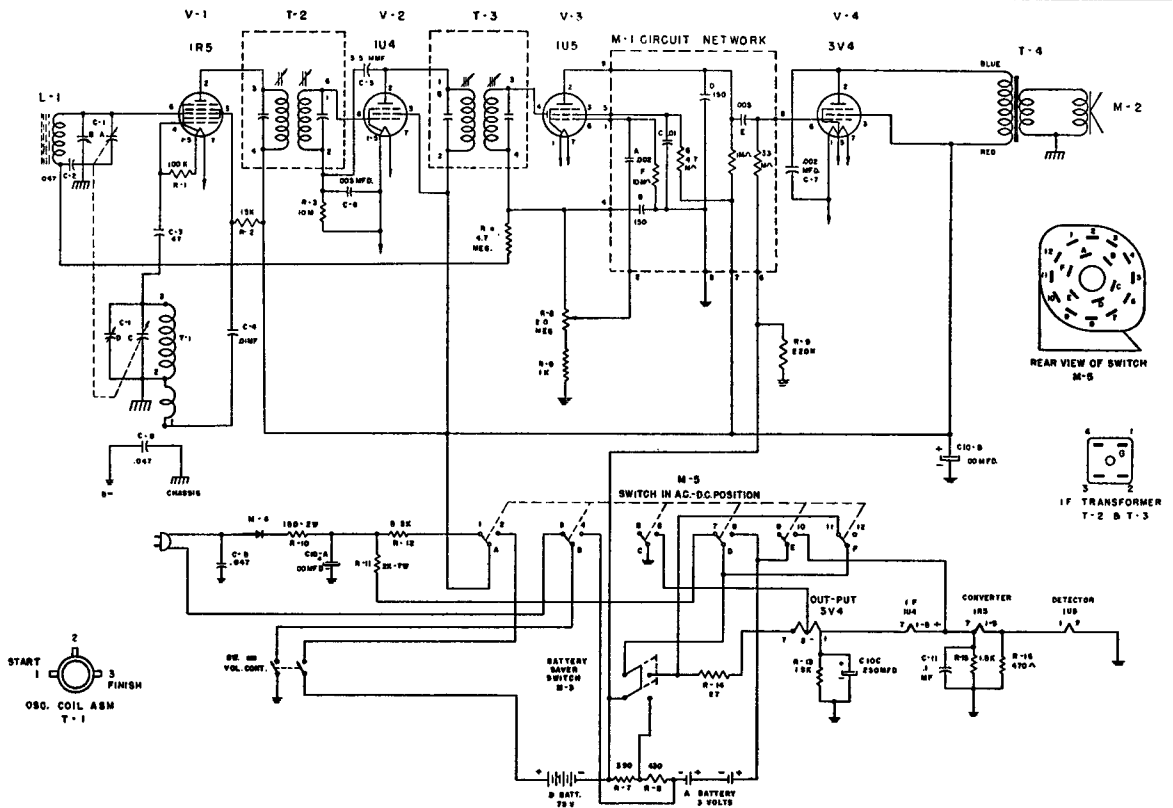

MANUAL OF 1955 MOST-OFTEN-NEEDED RADIO DIAGRAMS

SYLVANIA

MODEL 918 HI-FI PHONOGRAPH

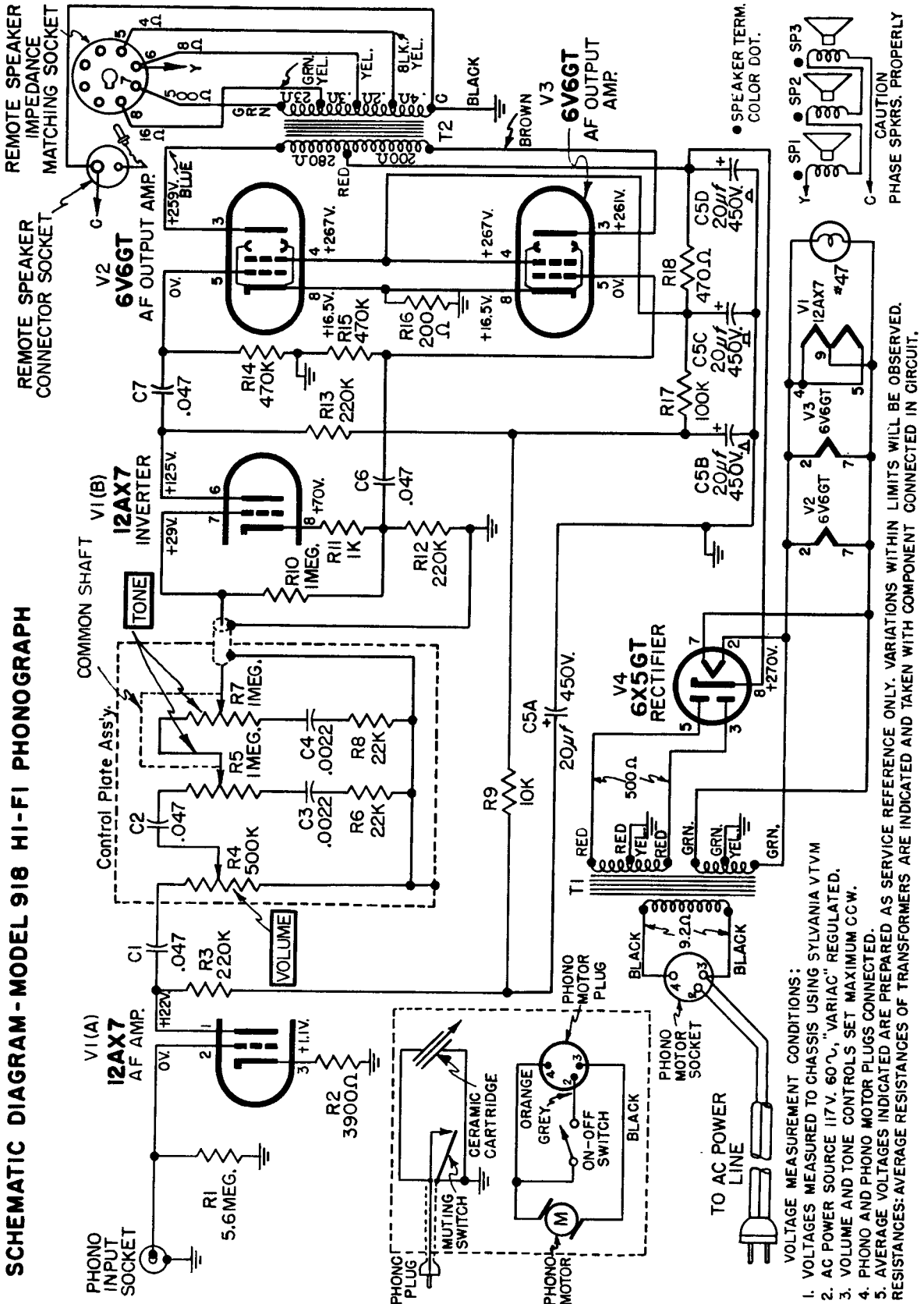

Sylvania Electric Products Inc., Radio & Television Div., Service Dept., Buffalo 7, N. Y.

MANUAL OF 1955 MOST-OFTEN-NEEDED RADIO DIAGRAMS

SYLVANIA

RADIO & TELEVISION

(Alignment on next page at right)

CHASSIS	I-602-4	I-602-5	I-602-6	I-602-7
USED IN MODELS	548	518	598	5484

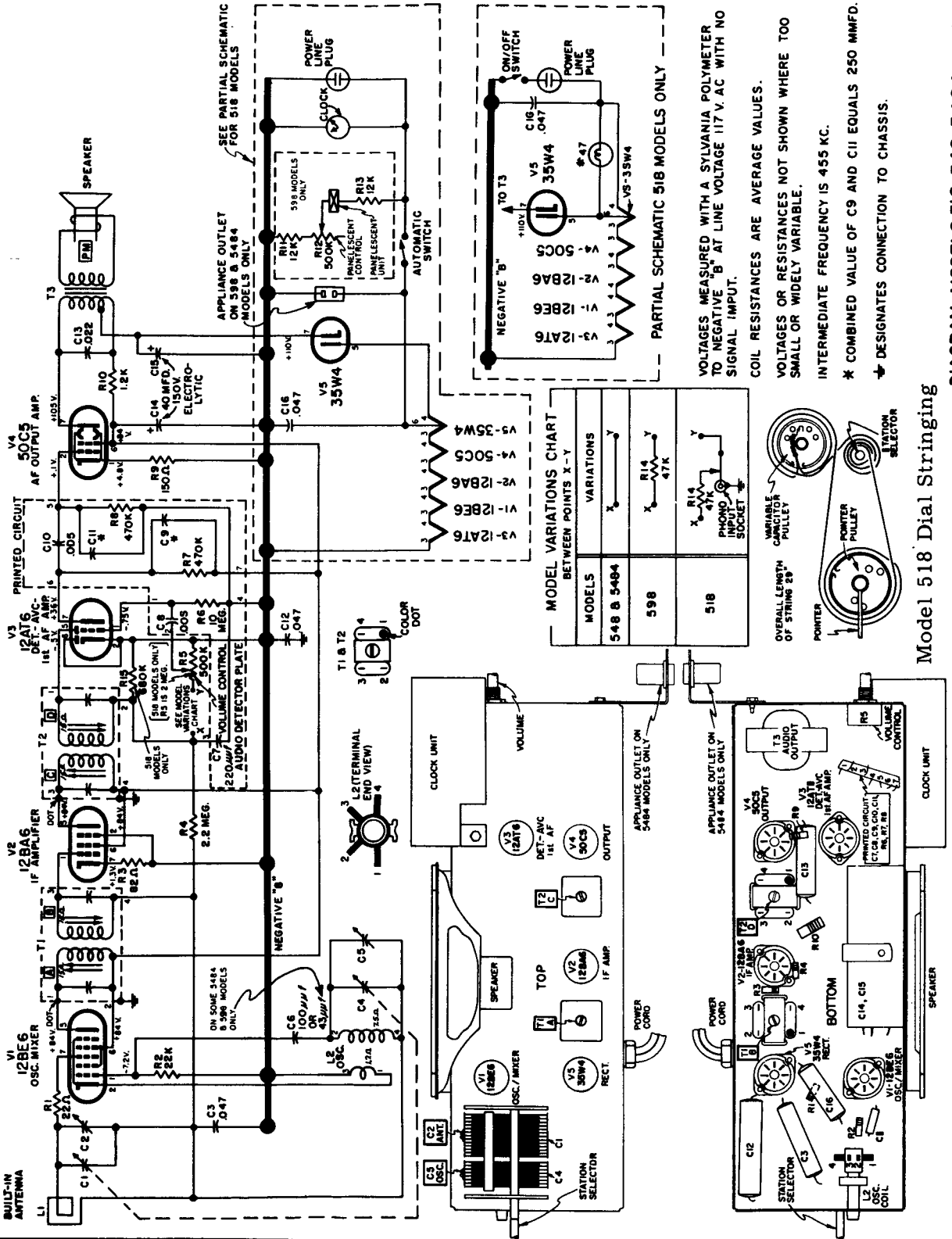

MODELS	VARIATIONS
548 & 5484	X
598	X, R14 47K
518	X, R14 47K, PHONO INPUT SOCKET

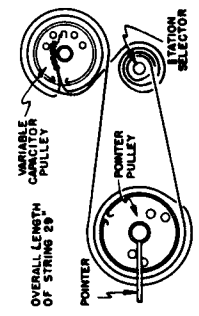

Model 518 Dial Stringing

PARTS LAYOUT - MODELS 548 and 5484

PARTIAL SCHEMATIC 518 MODELS ONLY

NEGATIVE "B"

VOLTAGES MEASURED WITH A SYLVANIA POLYMER METER TO NEGATIVE "B" AT LINE VOLTAGE 117 V. AC WITH NO SIGNAL INPUT.

COIL RESISTANCES ARE AVERAGE VALUES.

VOLTAGES OR RESISTANCES NOT SHOWN WHERE TOO SMALL OR WIDELY VARIABLE.

INTERMEDIATE FREQUENCY IS 455 KC.

* COMBINED VALUE OF C9 AND C11 EQUALS 250 MMFD.

† DESIGNATES CONNECTION TO CHASSIS.

DIAGRAM - MODELS 518, 548, 5484 and 598

MANUAL OF 1955 MOST-OFTEN-NEEDED RADIO DIAGRAMS

SYLVANIA Chassis 1-602-4, 1-602-5, 1-602-6, 1-602-7, used in Models 548, 518, 598, 5484 (Continued from previous page.)

ALIGNMENT PROCEDURE

Set generator for an RF output signal amplitude modulated (AM) with 400 cycles.

Use either an audible check or connect an AC voltmeter across speaker voice coil to indicate volume.

STEP	ALIGNMENT SETUP NOTES	TEST EQUIPMENT HOOKUP	ADJUST
1.	Set radio variable tuning capacitor to minimum capacity (tuning capacitor plates fully open).	SIGNAL GENERATOR - "hot" lead through .01 mfd. capacitor to pin 7 of V1, 12BE6; ground lead to negative "B" in receiver. Set generator to 455 KC. AC VOLTMETER - across radio speaker voice coil.	T2-D for MAXIMUM output. T2-C for MAXIMUM output. T1-B for MAXIMUM output. T1-A for MAXIMUM output. Repeat for optimum performance.
2.	Set radio variable tuning capacitor to minimum capacity (tuning capacitor plates fully open).	SIGNAL GENERATOR - radiate signal to receiver through a loop of several turns of wire. Set generator to 1650 KC. AC VOLTMETER - across radio speaker voice coil.	C5 trimmer for MAXIMUM output.
3.	Set radio variable tuning capacitor so plates are meshed approximately 3/16 inch. Adjust this setting slightly to eliminate any interfering signals.	SIGNAL GENERATOR - radiate signal to receiver through a loop of several turns of wire. Set generator to a frequency corresponding to receiver tuning capacitor setting or until signal is heard through radio speaker. AC VOLTMETER - across radio speaker voice coil.	C2 trimmer for MAXIMUM output.

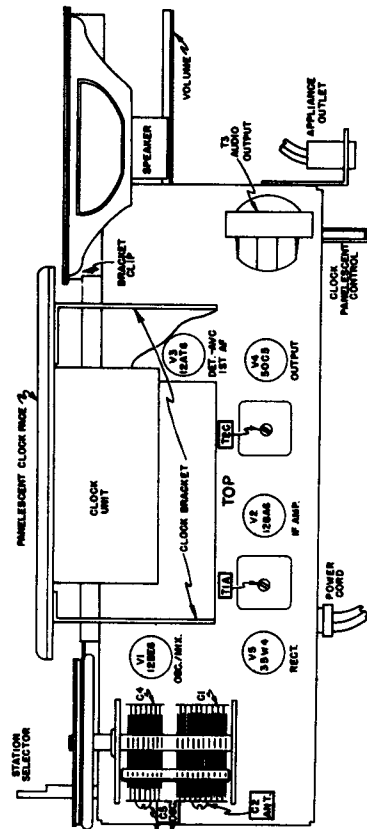
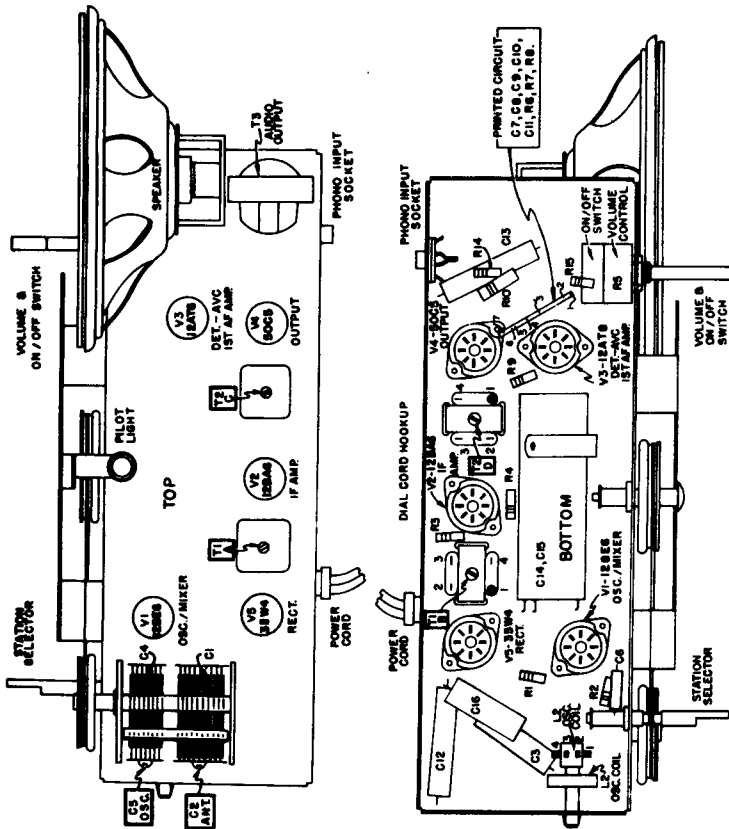

MANUAL OF 1955 MOST-OFTEN-NEEDED RADIO DIAGRAMS

SYLVANIA RADIO & TELEVISION

CHASSIS 1-605-1 MODEL 614

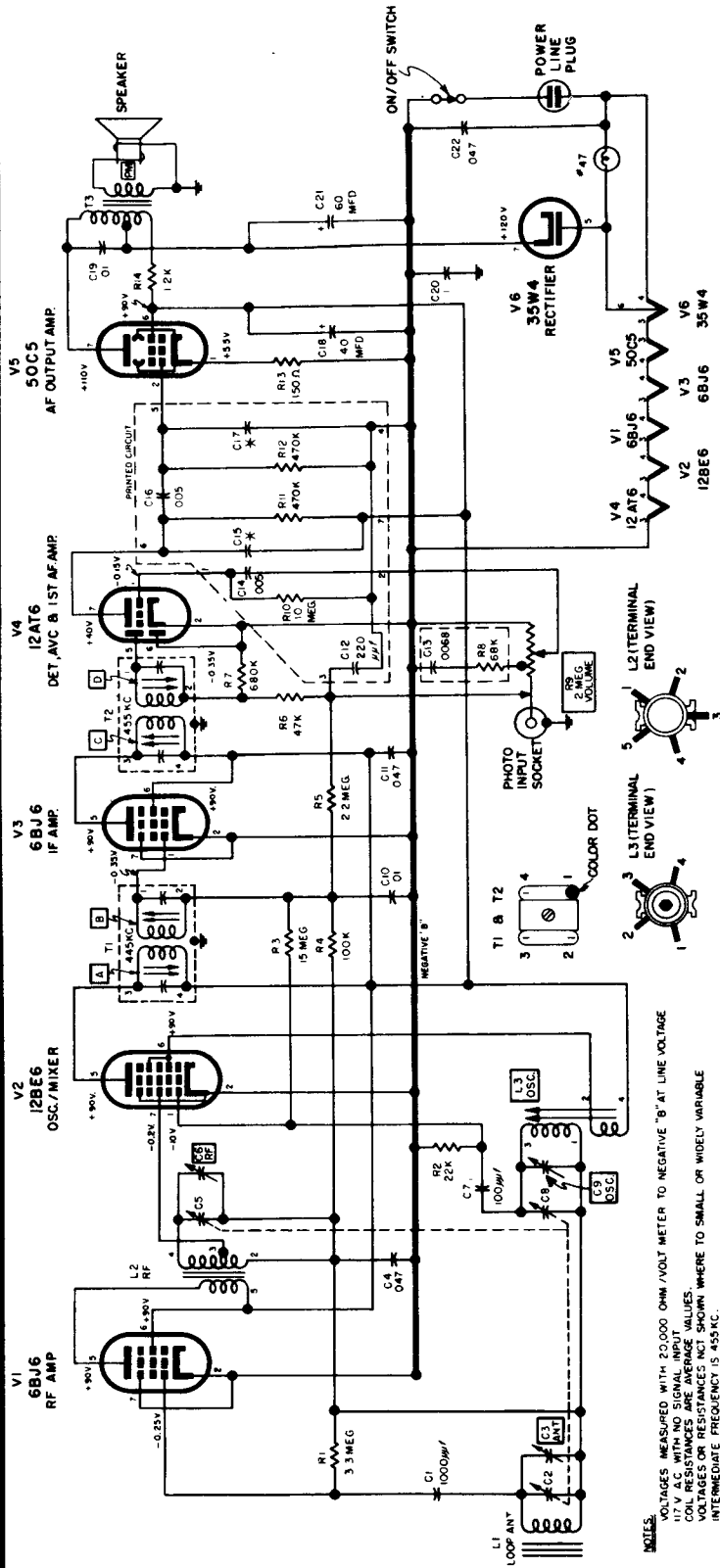

NOTES:
 VOLTAGES MEASURED WITH 20,000 OHM/VOLT METER TO NEGATIVE "B" AT LINE VOLTAGE
 117 V. A.C. WITH NO SIGNAL INPUT
 COIL RESISTANCES ARE AVERAGE VALUES
 VOLTAGES OR RESISTANCES NOT SHOWN WHERE TO SMALL OR WIDELY VARIABLE
 * COMBINED VALUE OF C15 AND C17 EQUALS 250 MMFD.
 † DESIGNATES CONNECTION TO CHASSIS.

SPECIFICATIONS

Power Supply . . . 25 to 60 Cycle AC, 117 Volts
 or DC, 117 Volts
 Power Consumption 30 Watts
 Frequency Range 540 KC to 1650 KC
 Intermediate Frequency 455 KC
 Loudspeaker 5" P.M.

TUBE COMPLEMENT

V1	RF Amplifier	6BJ6
V2	RF Oscillator/Mixer	12BE6
V3	IF Amplifier	6BJ6
V4	Detector, AVC & 1st AF Amp.	12AT6
V5	Audio Output Amplifier	50C5
V6	Rectifier	35W4

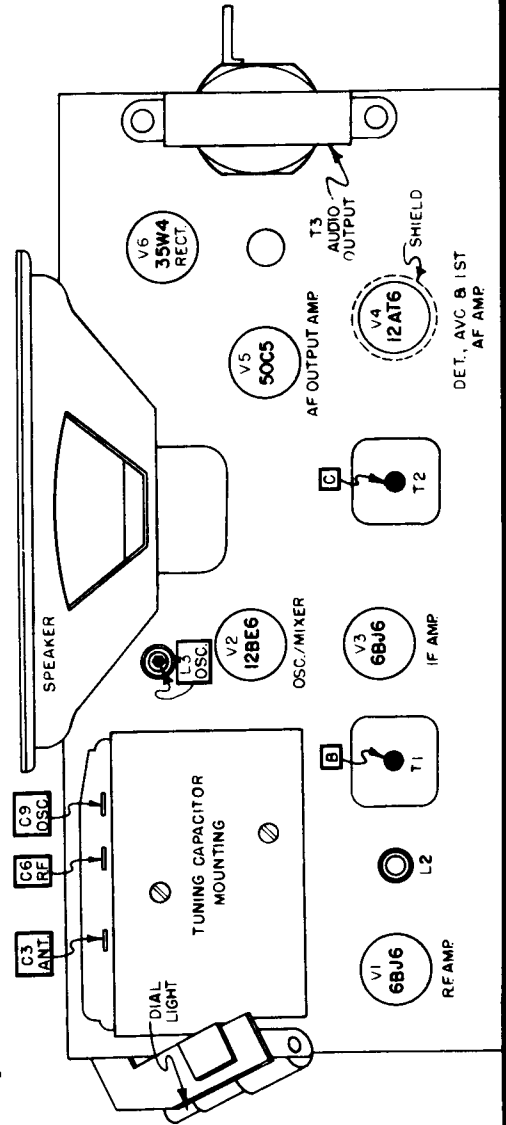

MANUAL OF 1955 MOST-OFTEN-NEEDED RADIO DIAGRAMS

TRAVLER

Models 55-37, 55-38, 55-39.

Schematic diagram below is exact for Model 55-37. Filter circuit with tapped output transformer used in Models 55-38 and 55-39 is shown in part at the right.

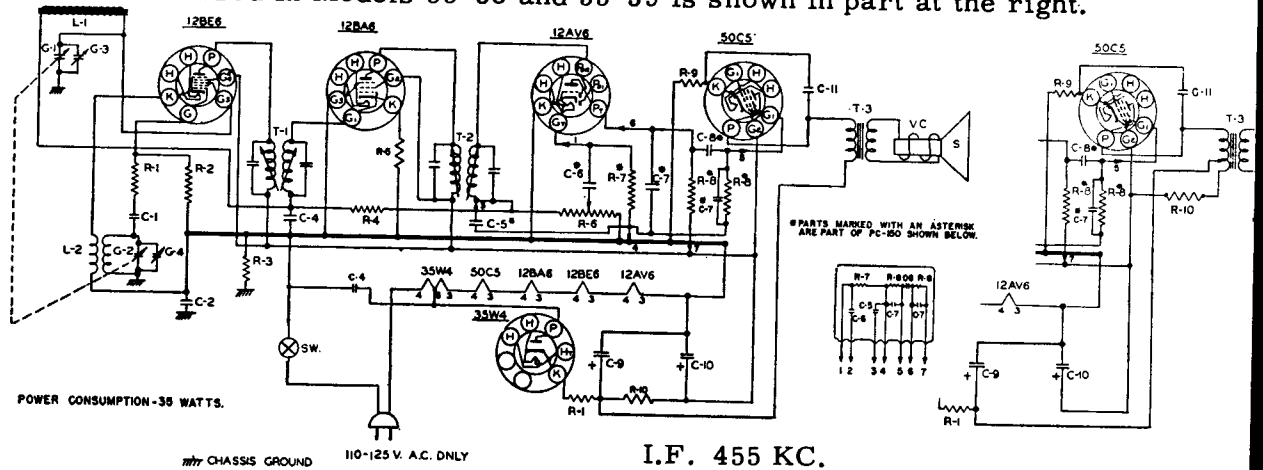

POWER CONSUMPTION-36 WATTS.

CHASSIS GROUND 110-125 V. A.C. ONLY

I.F. 455 KC.

PART NO.	DESCRIPTION	PART NO.	DESCRIPTION	PART NO.	DESCRIPTION
IR-17	R-1 33Ω RESISTOR 1/2W. 20%	GC-12	C-1 47 MMFD CERAMIC CONDENSER	SPK-37	S 4" P.M. SPEAKER
IR-9	R-2 22MΩ RESISTOR 1/2W. 20%	PC-2	C-2 1MFD. CONDENSER 400 V.		V.C. VOICE COIL
IR-20	R-3 220MΩ RESISTOR 1/2W. 20%	PC-5	C-4 05MFD. CONDENSER 400 V.	T-3 OUTPUT TRANSFORMER	
IR-23	R-4 3.3MEG. RESISTOR 1/2W. 20%	MC-19	C-5* 220 MMFD.	LL-58 L-1 FERRAMIC ROD ANTENNA	
IR-97	R-5 47Ω RESISTOR 1/2 W. 10%		C-6* 002 MMFD.	LO-21 L-2 OSC. COIL	
MC-19	R-6 1 MEG. VOLUME CONTROL	C-7* 250 MMFD	EG-55	C-9 50 MFD. -150W.V.D.C. ELECTROLYTIC	
	R-7 1 MEG. VOLUME CONTROL	C-8* 005 MMFD.			
IR-114	R-8 470MΩ	C-9 50 MFD.	GC-15	G-1 TUNING CONDENSER	
IR-114	R-9 220Ω RESISTOR 1/2W. 20%	C-10 50 MFD.			
IR-25	R-10 2200Ω RESISTOR 1W 10%	C-11 0.005MFD. CONDENSER	G-2		
LI-13	T-1 INPUT I.F. TRANSFORMER				
	T-2 OUTPUT I.F. TRANSFORMER				

Models 521R90 - 521R91 - 5510

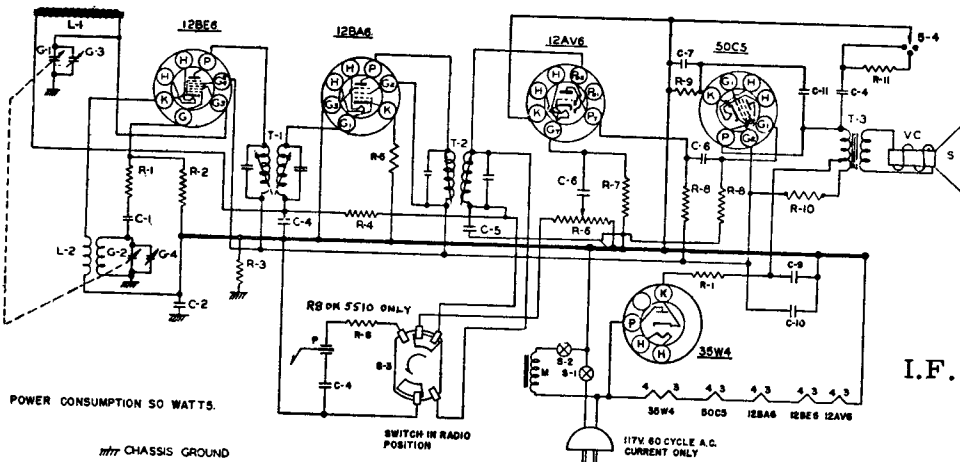

POWER CONSUMPTION 50 WATTS.

CHASSIS GROUND

SWITCH IN RADIO POSITION

117V. 60 CYCLE A.C. CURRENT ONLY

I.F. 455 KC.

PART NO.	DESCRIPTION	PART NO.	DESCRIPTION	PART NO.	DESCRIPTION
IR-17	R-1 33Ω RESISTOR 1/2W. 20%	GC-12	C-1 47 MMFD CERAMIC CONDENSER	SPK-38	S 4" P.M. SPEAKER
IR-9	R-2 22MΩ RESISTOR 1/2W. 20%	PC-6	C-2 1MFD. CONDENSER 400 V.		V.C. VOICE COIL
IR-20	R-3 220MΩ RESISTOR 1/2W. 20%	PC-5	C-4 05MFD. CONDENSER 400 V.	T-3 OUTPUT TRANSFORMER	
IR-23	R-4 3.3MEG. RESISTOR 1/2W. 20%	GC-5	C-5 100MMFD CERAMIC CONDENSER	LL-59 L-1 FERRAMIC ROD ANTENNA	
IR-13	R-5 220Ω RESISTOR 1/2 W. 0%	PC-7	C-6 .01 MFD CONDENSER 400V.	LO-21 L-2 OSC. COIL	
IR-114	R-6 1 MEG. VOLUME CONTROL	EG-54	C-7 5 MFD. @ 25 W.V.D.C. ELECTROLYTIC	S-1 SWITCH ON VOLUME CONTROL	
IR-11	R-7 2.2MEG. RESISTOR 1/2W. 20%	EG-53	C-9 50 MFD.	S-2 SWITCH ON RECORD CHANGER	
IR-11	R-8 470MΩ RESISTOR 1/2W. 20%			C-10 50 MFD. -150W.V.D.C. ELECTROLYTIC	P PICKUP CARTRIDGE
IR-114	R-9 220Ω RESISTOR 1/2W. 20%	GC-5	C-11 0.005MFD. CONDENSER	M CHANGER MOTOR	
IR-42	R-10 1000Ω RESISTOR 1W 10%	GC-18	G-1 TUNING CONDENSER	S-3 RADIO-PHONO SWITCH	
IR-18	R-11 4700Ω RESISTOR 1/2W. 20%			G-2	S-4 TONE CONTROL SWITCH
LI-13	T-1 INPUT I.F. TRANSFORMER				
	T-2 OUTPUT I.F. TRANSFORMER				

MANUAL OF 1955 MOST-OFTEN-NEEDED RADIO DIAGRAMS

UNITED MOTORS

DIVISION OF GENERAL MOTORS

Chevrolet Model 987087

(Alignment on next page at right)

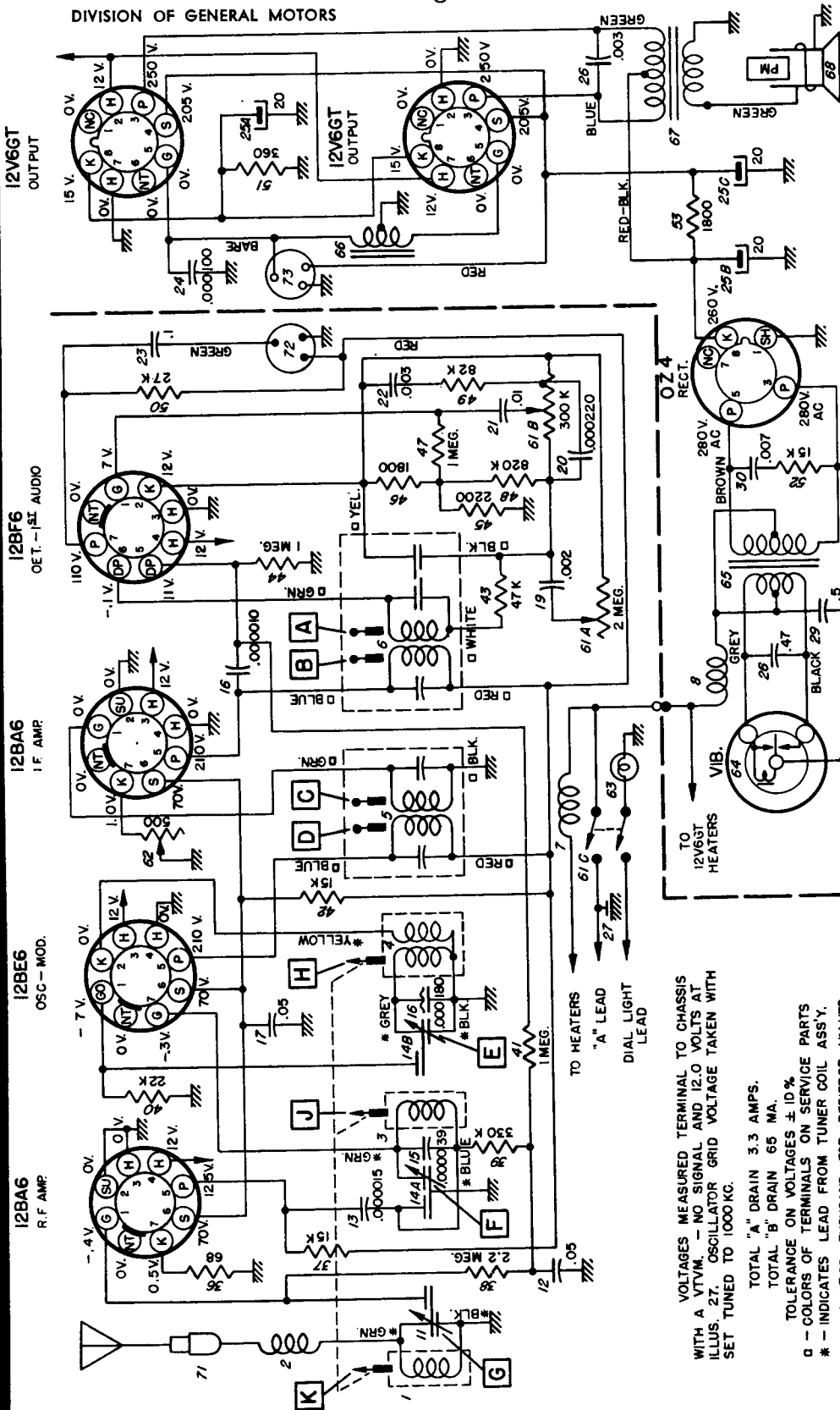

VOLTAGES MEASURED TERMINAL TO CHASSIS WITH A VTVM. - NO SIGNAL AND 12.0 VOLTS AT ILLUS. 27. OSCILLATOR GRID VOLTAGE TAKEN WITH SET TUNED TO 1000 KC.

TOTAL "A" DRAIN 3.3 AMPS.

TOTAL "B" DRAIN 65 MA.

TOLERANCE ON VOLTAGES ± 10 %

Q - COLORS OF TERMINALS ON SERVICE PARTS

* - INDICATES LEAD FROM TUNER COIL ASS'Y.

K - INDICATES THOUSAND FOR RESISTOR VALUES.

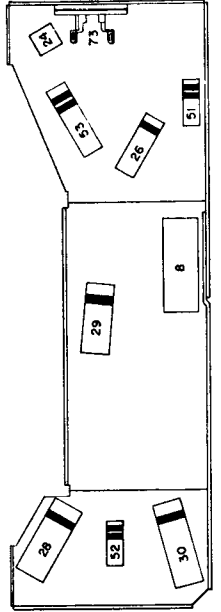

PARTS LAYOUT - CHASSIS VIEW (POWER SUPPLY)

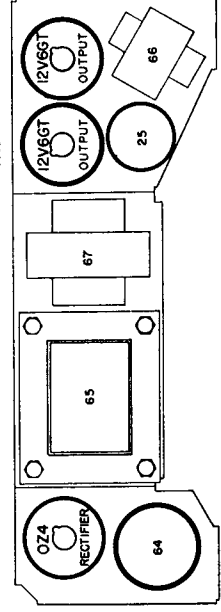

PARTS LAYOUT - TUBE VIEW (POWER SUPPLY)

MANUAL OF 1955 MOST-OFTEN-NEEDED RADIO DIAGRAMS

UNITED MOTORS

Chevrolet
Model 987087

(Continued from
adjacent page at
left).

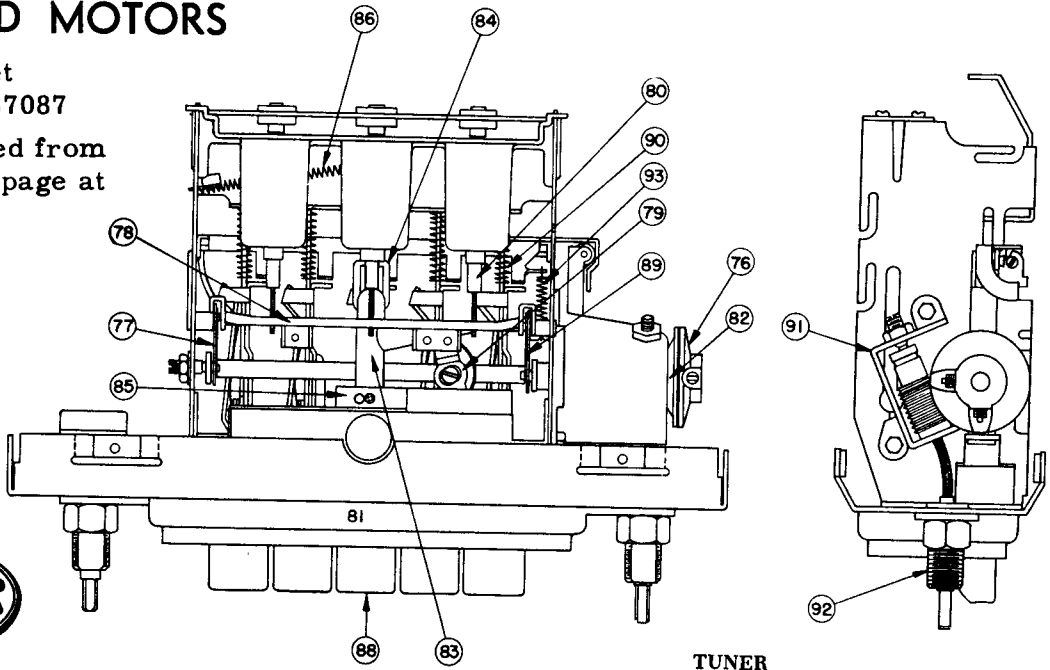

TUNER

ALIGNMENT PROCEDURE

Steps	Series Capacitor or Dummy Antenna	Connect Signal Generator to	Signal Generator Frequency	Tune Receiver to	Adjust in Sequence For Max. Output
1	0.1 Mfd.	12BE6 Grid (Pin #7)	262 KC	High Frequency Stop	A, B, C, D
2	0.000082 Mfd.	Antenna Connector	1615 KC	High Frequency Stop	*E, F, G
3	0.000082 Mfd.	Antenna Connector	1000 KC	Signal Generator Signal	J, K
4	0.000082 Mfd.	Antenna Connector	1615 KC	High Frequency Stop	F, G
5	0.000082 Mfd.	Antenna Connector	900 KC	Signal Generator Signal	L**

*Before making this adjustment check mechanical setting of oscillator core "H." The rear of the core should be $1\frac{1}{8}$ " from the mounting end of the coil form. (This measurement is readily made by inserting a suitable plug in the mounting end of the coil form.) Core adjustment should be made with an insulated screw driver.

**L is the pointer adjustment screw which is on the connecting link, between the pointer assembly and core guide bar (See tuner Dwg.). It should be adjusted so that when looking directly at the dial the pointer is on the 900 KC mark. This setting is to give the correct relationship between the pointer and the dial when the radio is installed in a car.

With the radio installed and the car antenna plugged in adjust the antenna trimmer "G" for maximum volume with the radio tuned to a weak station between 600 and 1000 KC (see sticker on case.)

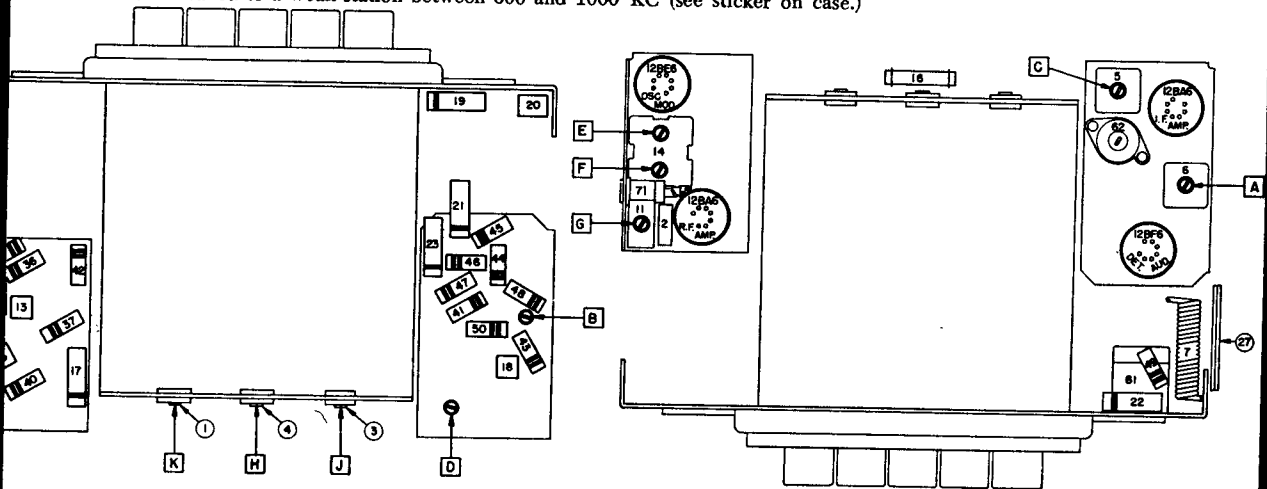

PARTS LAYOUT — CHASSIS VIEW

PARTS LAYOUT — TUBE VIEW

MANUAL OF 1955 MOST-OFTEN-NEEDED RADIO DIAGRAMS

UNITED MOTORS

Chevrolet Model 987088
(Alignment on the next page)

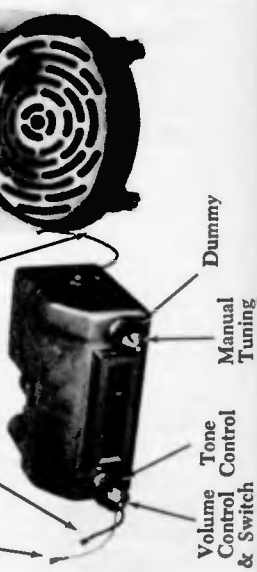
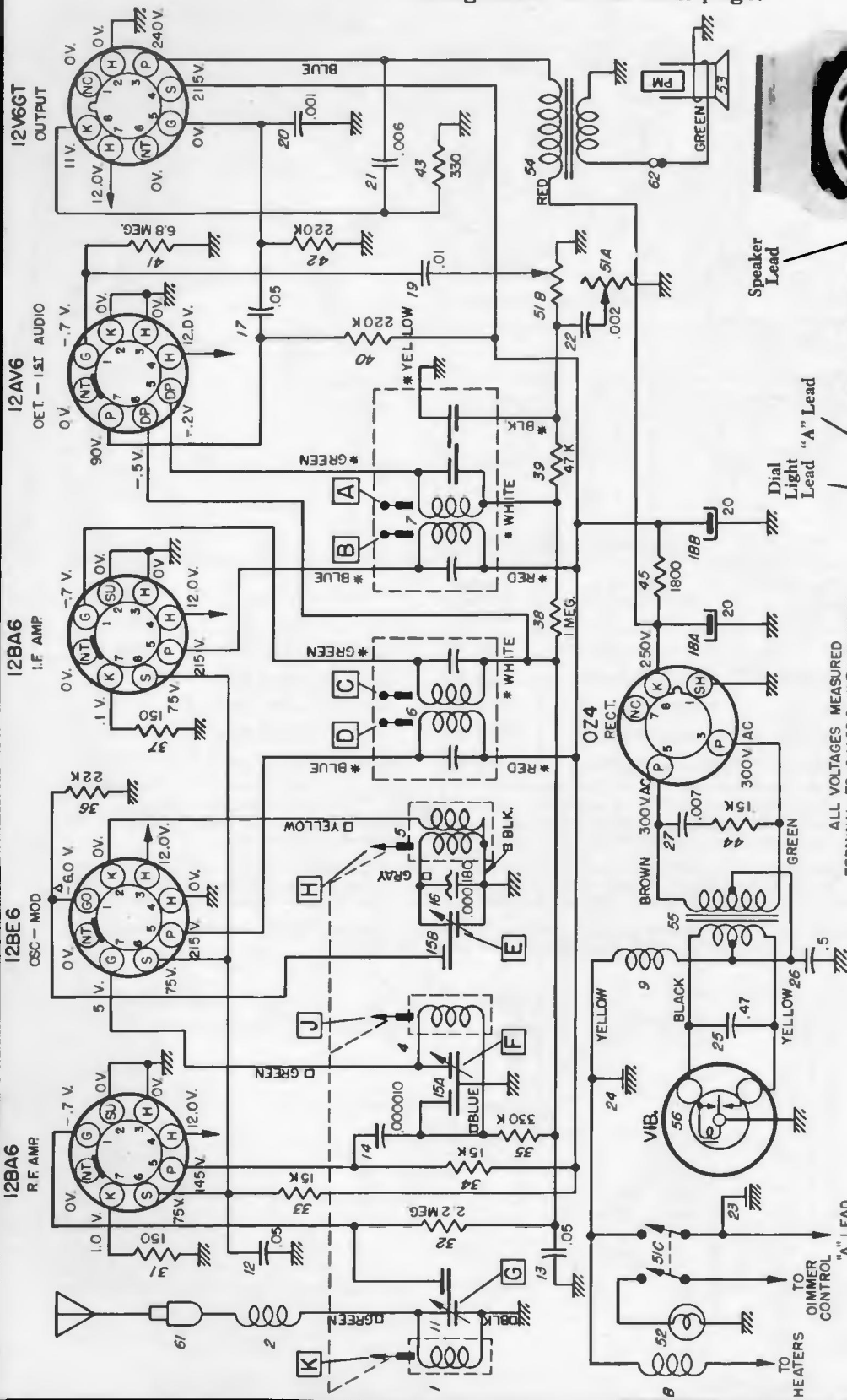

ALL VOLTAGES MEASURED
TERMINAL TO CHASSIS WITH VACUUM
TUBE VOLT METER. - NO SIGNAL
AND 12.D V AT ILLUS. 23.
TOTAL "A" DRAIN 2.5 AMPS.
TOTAL "B" DRAIN 50 MA.
TOLERANCE ON VOLTAGES ± 10%.



- ▲ - OSCILLATOR GRID VOLTAGE AT 1000 KC.
- * - COLORS OF TERMINALS ON SERVICE PARTS.
- - INDICATES LEADS FROM COIL ASSEMBLY.
- K - INDICATES THOUSAND FOR RESISTOR VALUES.

MANUAL OF 1955 MOST-OFTEN-NEEDED RADIO DIAGRAMS

UNITED MOTORS

Chevrolet Model 987088
(Continued from page at left)

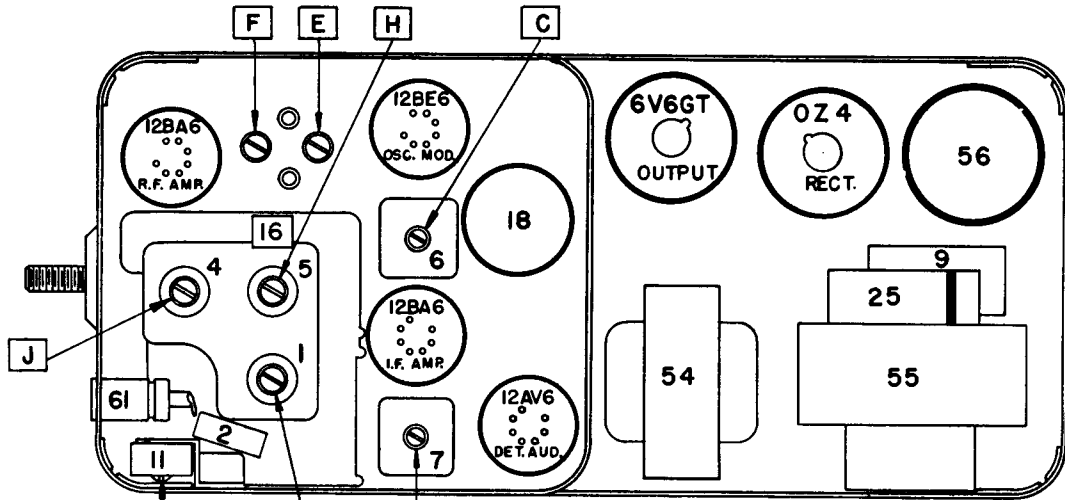

PARTS LAYOUT — TUBE VIEW

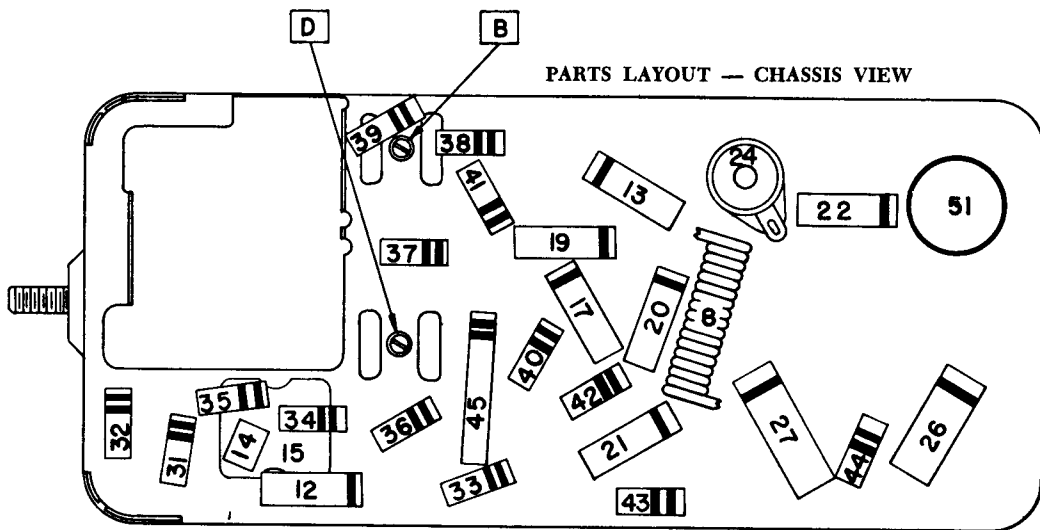

PARTS LAYOUT — CHASSIS VIEW

ALIGNMENT PROCEDURE

Steps	Series Capacitor or Dummy Antenna	Connect Signal Generator to	Signal Generator Frequency	Tune Receiver to	Adjust in Sequence For Max. Output
1	0.1 Mfd.	12BE6 Grid (Pin #7)	262 KC	High Frequency Stop	A, B, C, D
2	0.000082 Mfd.	Antenna Connector	1615 KC	High Frequency Stop	*E, F, G
3	0.000082 Mfd.	Antenna Connector	1000 KC	Signal Generator Signal	J, K
4	0.000082 Mfd.	Antenna Connector	1615 KC	High Frequency Stop	F, G
5	0.000082 Mfd.	Antenna Connector	900 KC	Signal Generator Signal	**

*Before making this adjustment check mechanical setting of oscillator core "H." The rear of the core should be $1\frac{1}{2}$ " from the mounting end of the coil form. (This measurement is readily made by inserting a suitable plug in the mounting end of the coil form.) Core adjustment should be made with an insulated screw driver.

**Tune in 900 KC signal and adjust pointer on the dial cord so that the pointer is on the 900 KC mark of the dial. This setting is to give the correct relationship between the pointer and dial when the radio is installed in a car.

With the radio installed and the car antenna plugged in adjust the antenna trimmer "G" for maximum volume with the radio tuned to a weak station between 600 and 1000 KC (see sticker on case.)

MANUAL OF 1955 MOST-OFTEN-NEEDED RADIO DIAGRAMS

UNITED MOTORS

Pontiac Model 984961
(Alignment on the next page)

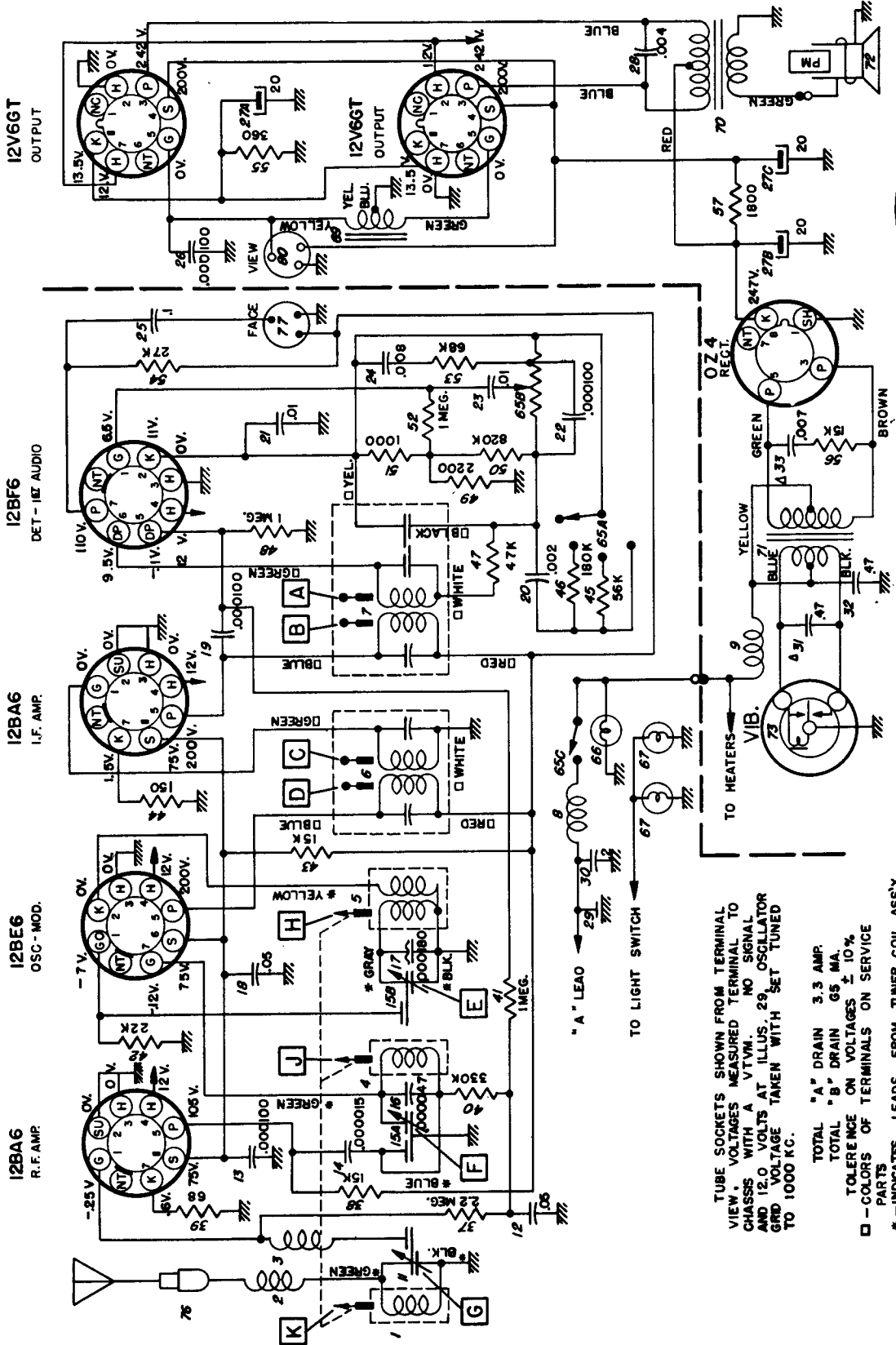

TUBE SOCKETS SHOWN FROM TERMINAL VIEW. VOLTAGES MEASURED FROM TERMINAL TO CHASSIS WITH A VTVM. NO SIGNAL AND 12.0 VOLTS AT ILLUS. 29. OSCILLATOR GRID VOLTAGE TAKEN WITH SET TUNED TO 1000 KC.

TOTAL "A" DRAIN 3.3 AMP.
TOTAL "B" DRAIN 65 MA.
TOLERANCE ON VOLTAGES ± 10%
□ - COLORS OF TERMINALS ON SERVICE PARTS
* - INDICATES LEADS FROM TUNER COIL ASS'Y
Δ - SOME RADIOS HAVE ILLUSTRATION 31 OMITTED AND USE A .008 MFD. BUFFER (ILLUST. 35)
K - Indicates thousand for resistor values.

PONTIAC MODEL 984961

MANUAL OF 1955 MOST-OFTEN-NEEDED RADIO DIAGRAMS

UNITED MOTORS
Pontiac Model 984961
(Continued)

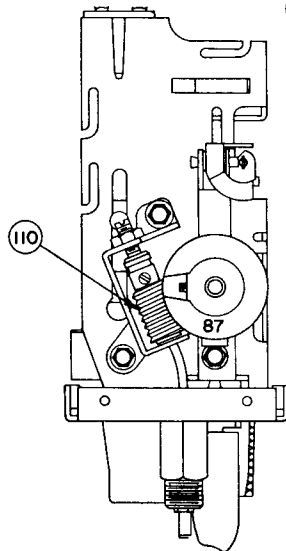
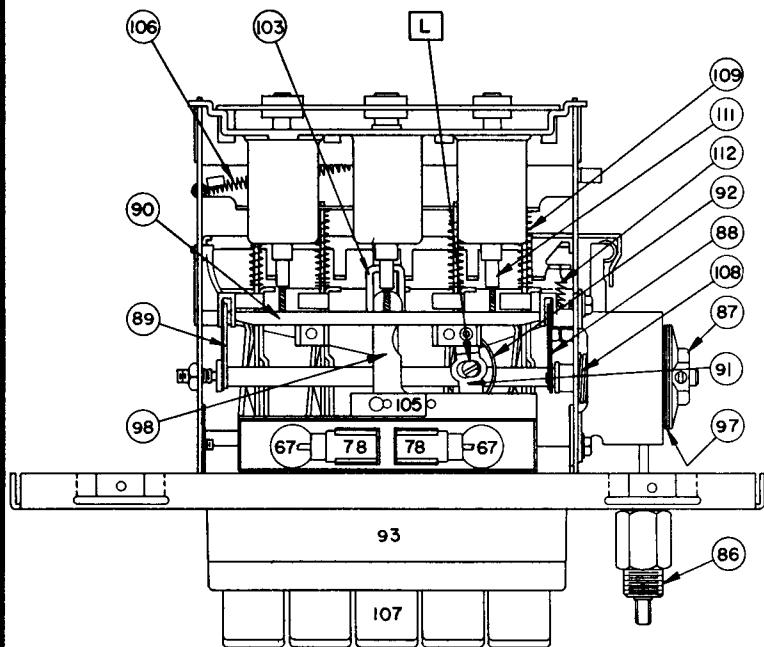

TUNER

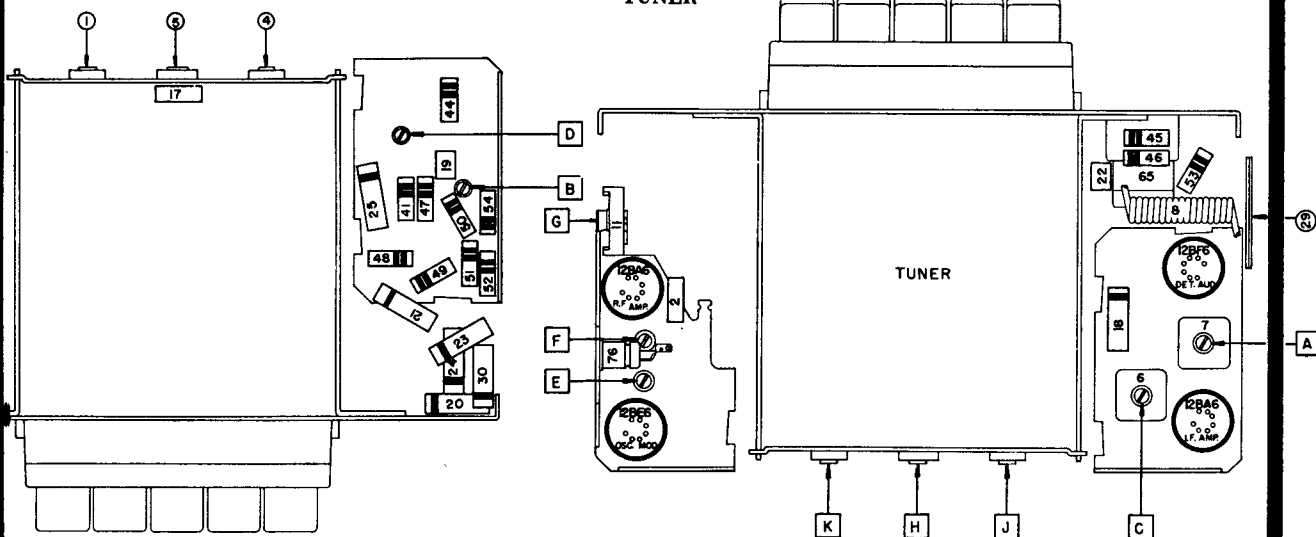

LAYOUT — CHASSIS VIEW (RADIO)

PARTS LAYOUT — TUBE VIEW (RADIO)

Steps	Series Capacitor or Dummy Antenna	Connect to	Signal Generator Frequency	Tune Receiver to	Adjust in Sequence For Max. Output
1	0.1 Mfd.	12BE6 Grid (Pin # 7)	262 KC	High Frequency Stop	A, B, C, D
2	0.000068 Mfd.	Antenna Connector	1615 KC	High Frequency Stop	*E, F, G
3	0.000068 Mfd.	Antenna Connector	1000 KC	Signal Generator Signal	J, K
4	0.000068 Mfd.	Antenna Connector	1615 KC	High Frequency Stop	F, G
5	0.000068 Mfd.	Antenna Connector	1000 KC	Signal Generator Signal	**L

*Before making this adjustment check the mechanical setting of the oscillator core "H." The slotted end of core should be $1\frac{1}{2}$ " from the mounting end of the coil form. (This measurement is readily made by inserting a suitable plug in the mounting end of the coil form.) If adjustment is necessary, first dissolve the glyptal seal on the studs. Core adjustment should be made with an insulated screwdriver and core studs should be re-sealed in place with glyptal or household cement after alignment.

**"L" is the pointer adjustment screw which is on the pointer connecting link (see tuner drawing) and should be adjusted so the pointer reads 1000 KC. (Dot between 9 and 11.)

With the radio installed and the car antenna plugged in adjust the antenna trimmer "C" for maximum volume with the radio tuned to a weak station between 600 and 1000 KC. (See sticker on case.)

MANUAL OF 1955 MOST-OFTEN-NEEDED RADIO DIAGRAMS

UNITED MOTORS

Cadillac Models 7265825 and 7265845

(Continued from adjacent page at left).

DIVISION OF GENERAL MOTORS

SIGNAL SEEKING TUNER ALIGNMENT PROCEDURE:

Output Meter Connection VTVM From AVC Line To Chassis (see parts layout)
 Generator Return Receiver Chassis
 Dummy Antenna In Series With Generator
 Volume Control Maximum Volume
 Sensitivity Control Maximum Sensitivity

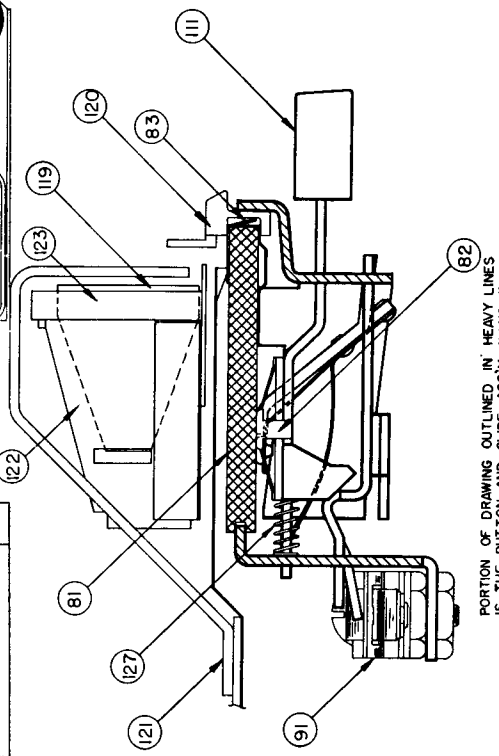
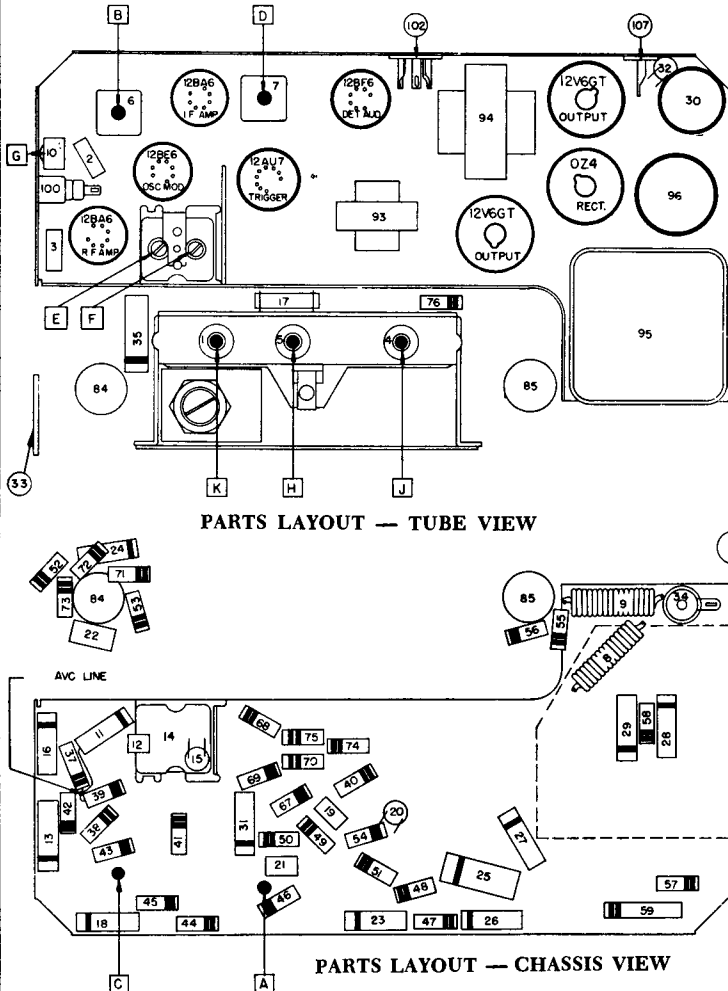

PORTION OF DRAWING OUTLINED IN HEAVY LINES IS THE BUTTON AND SLIDE ASS'Y, ILLUS III.
TUNER BUTTON MECHANISM - CROSS SECTION



Step	Dummy Antenna	Connect To	Signal Generator Frequency	Tune Receiver To	Adjust in Sequence for Output Indicated
1	0.1 mfd	12BE6 Grid (Pin 7)	262 KC	*High Frequency Stop	A, B, C (Max.)
2	0.1 mfd	12BE6 Grid (Pin 7)	262 KC	High Frequency Stop	D (Min.)
3	0.000068 mfd	Antenna Connector	1615 KC	High Frequency Stop	**E, F, G (Max.)
4	0.000068 mfd	Antenna Connector	600 KC	Signal Gen. Signal	J, K (Max.)
5	0.000068 mfd	Antenna Connector	1615 KC	Signal Gen. Signal	F, G (Max.)
6	0.000068 mfd	Antenna Connector	1000 KC	Signal Gen. Signal	***L

*To tune to high frequency, put a 0.070" feeler gauge (or bare # 13 wire) in slot against the high frequency stop. Depress station selector bar and allow the planetary arm to run against the feeler gauge. Turn the radio off and then on.

**Before making this adjustment, check the setting of oscillator core "H." The rear of the core should be 1 1/2" from the mounting end of the coil form. This measurement is readily made by inserting a suitable plug in the mounting end of the coil form. The core adjustment is made from the mounting end of the coil form with an insulated screwdriver. (It will be necessary to steady the core guide bar by applying a downward pressure at the antenna core end of the bar while making these adjustments.) If this adjustment is necessary, first dissolve the glyptal seal on the core stud and be sure to re-seal after making the adjustment.

***"L" is the pointer adjustment screw on the end of the core guide bar—adjust so pointer reads 1000 KC.

With the radio installed and the antenna plugged in, adjust antenna trimmer "G" (See sticker on case) for maximum volume with the radio tuned to a weak station between 600 and 1000 KC.

MANUAL OF 1955 MOST-OFTEN-NEEDED RADIO DIAGRAMS

Western Auto Supply Company

MODEL NOS. D2562A, D2563A

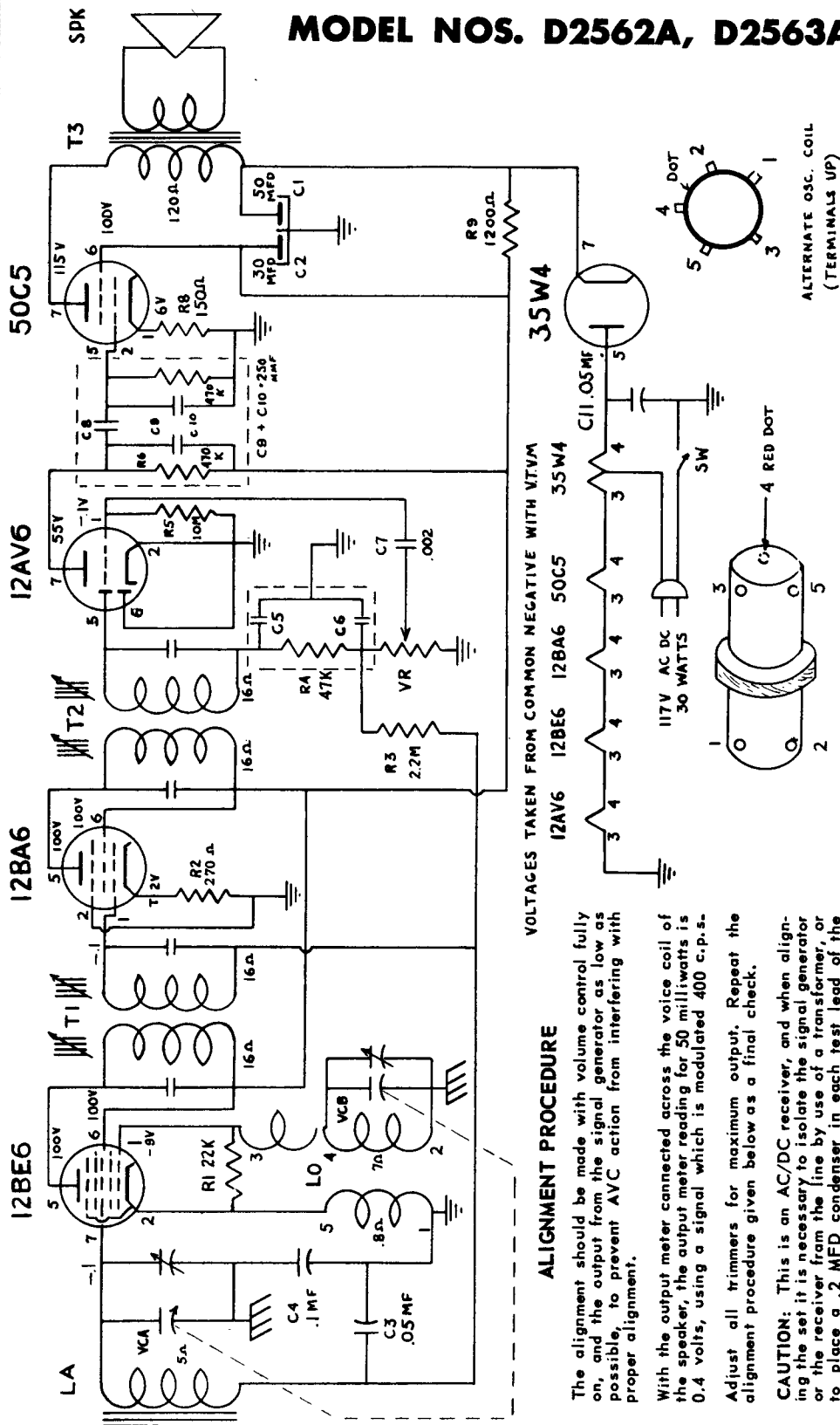

VOLTAGES TAKEN FROM COMMON NEGATIVE WITH VTVM

ALIGNMENT PROCEDURE

The alignment should be made with volume control fully on, and the output from the signal generator as low as possible, to prevent AVC action from interfering with proper alignment.

With the output meter connected across the voice coil of the speaker, the output meter reading for 50 milliwatts is 0.4 volts, using a signal which is modulated 400 c.p.s.

Adjust all trimmers for maximum output. Repeat the alignment procedure given below as a final check.

CAUTION: This is an AC/DC receiver, and when aligning the set it is necessary to isolate the signal generator or the receiver from the line by use of a transformer, or to place a .2 MFD condenser in each test lead of the signal generator.

SIGNAL GENERATOR Frequency	Dummy Connection to Radio Antenna	POSITION OF VARIABLE	ADJUST FOR MAXIMUM OUTPUT
455 KC	.1 MFD Stator VCA	Fully Open	T2 & T1
1625 KC	12BE6 Grid Stator VCA	Fully Open	VCB Oscillator
1400 KC	Loosely Coupled to Loop	Tune in Signal Generator	VCA Antenna

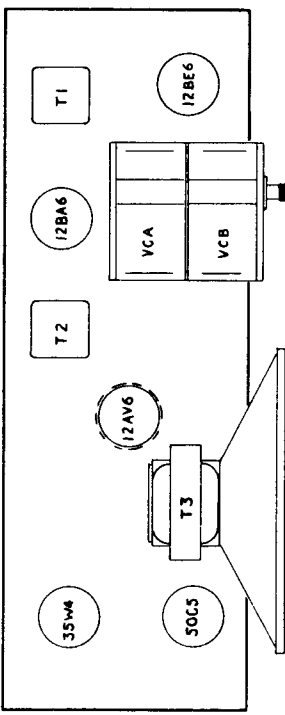

ALTERNATE OSC. COIL (TERMINALS UP)

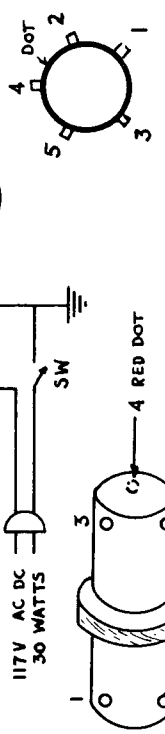

MANUAL OF 1955 MOST-OFTEN-NEEDED RADIO DIAGRAMS

8 PART OF PRINTED CIRCUIT PC-65
TRAILER PART NO. MC-18, SHOWN BELOW

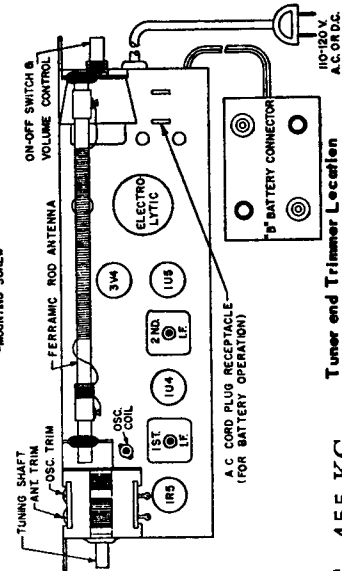
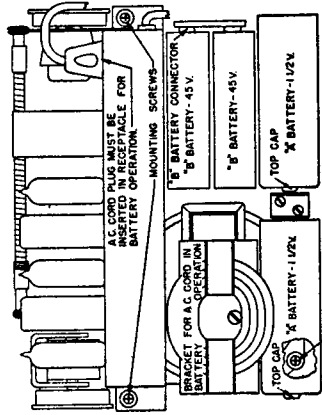
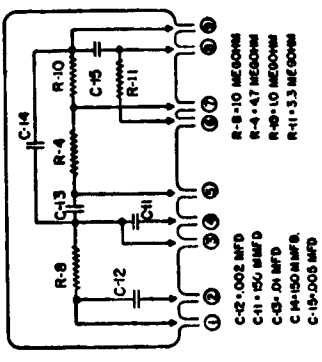

I.F. 455 KC.

Tuner end Trimmer Location

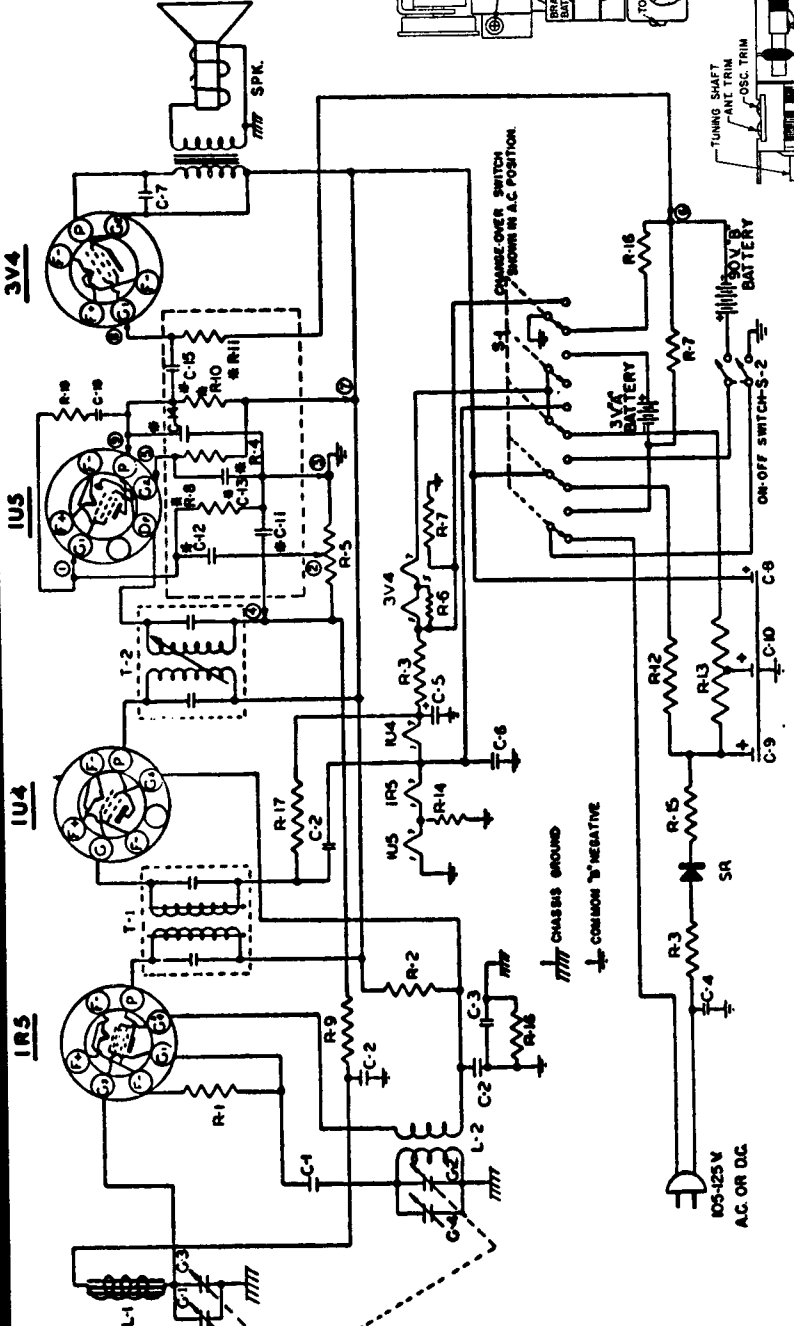

PART NO.	SYMBOL	DESCRIPTION	PART NO.	SYMBOL	DESCRIPTION
IR-43	R-1	100 K 1/2 W. 10% Resistor	C-8	40 MFD	150 V. Electrolytic Condenser
IR-65	R-2	15 K 1/2 W. 10% Resistor	C-9	40 MFD	
IR-17	R-3	33 1/2 W. 20% Resistor	C-10	20 MFD	Oscillator Coil
VC-47	R-5	1 MEGOHM Volume Control	L-1	Ferramic Rod Antenna	Input I.F. Transformer
IR-33	R-6	270 1/2 W. 10% Resistor	T-1	Output I.F. Transformer	
IR-39	R-7	620 1/2 W. 10% Resistor	T-2	Antenna Section	Tuning Capacitor
IR-3	R-12	10 MEGOHM 1/2 W. 20% Resistor	G-1	Oscillator Section	
IR-25	R-13	2200 1 W. 10% Resistor	G-2	Antenna Trimmer	6 Pole, 2 Position Switch
WR-7	R-14	2100 1 W. 5% Wirewound Resistor	G-3	Oscillator Trimmer	
IR-1	R-15	47 1 W. 10% Resistor	S-1	Volume Control	75 MIL Gallenium Rectifier
IR-41	R-16	33 MEGOHM 1/2 W. 20% Resistor	S-2	Volume Control	
IR-20	R-17	220 K 1/2 W. 20% Resistor	SR	4" P.M. Speaker with Output Transformer	
CC-3	C-1	100 MMFD Ceramic Condenser, 500 V.	SPK-29	SPK	
CC-4	C-2	.01 MFD Ceramic Condenser, 400 V.	IR-13	R-18	2.2 MEGOHM 1/2 W. 20% Resistor
PC-8	C-3	.1 MFD Paper Condenser, 400 V.	CC-33	C-16	220 MMFD 500 V. 20% Ceramic Condenser
PC-5	C-4	.05 MFD x 400 V. Paper Condenser	CA-155	Cabinet Complete	
CC-6	C-5	70 MFD @ 10 W.V. Electrolytic Condenser	K-153	Volume Knob	
PC-3	C-6	.1 MFD x 200 V. Paper Condenser	K-154	Tuner Knob	
CC-7	C-7	1500 MMFD x 500 V. Ceramic Condenser			

Western Auto Supply

MODEL NOS. D3503A, D3504A

MANUAL OF 1955 MOST-OFTEN-NEEDED Western Auto Supply Company MODEL NO. D4425B

Truetone Model D4426B uses practically the same circuit except that 12-volt tubes are employed.

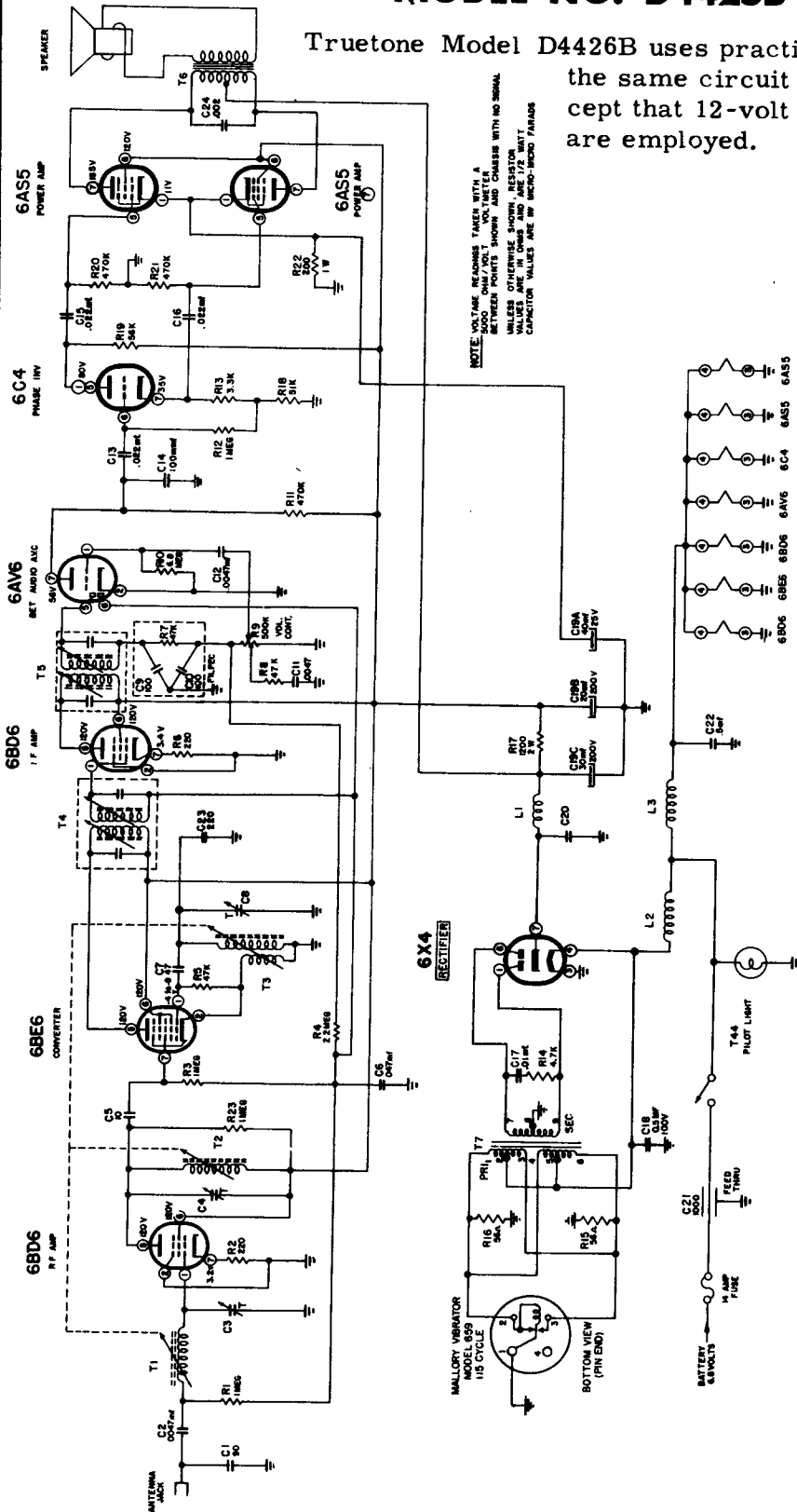

RF ALIGNMENT

1. Set the signal generator to 1620KC and turn tuning control fully counter-clockwise.
2. Adjust oscillator trimmer C8 for maximum deflection.
3. Disconnect the hot signal generator lead and .10 mfd. capacitor and reconnect to the antenna jack through a 50 mmf capacitor.
4. Turn volume control counter-clockwise to reduce noise indicated on output meter to a level of approximately 50 milliwatts.

IF ALIGNMENT

1. Connect the hot lead of the signal generator through a .10 mfd. capacitor to Pin 7 of the converter (6BE6) tube. Apply a 400 cycle, 30% modulated carrier of 455 KC at about 150 microvolts.
2. Set the volume control at maximum and adjust the top and bottom cores of the first and second IF transformers (T4 and T5) for maximum output, as indicated on the output meter. Keep signal generator level low.

5. Set the signal generator to 1400 KC and tune in the receiver for maximum reading on output meter. Keep signal generator level low.
6. Adjust antenna and R.F. trimmers C3 and C4 for maximum reading.

The tuner cores are adjusted and sealed at the factory, therefore core adjustments are not necessary. The entire tuning assembly is a complete unit. Individual parts will not be available as the entire assembly should be replaced as a unit, if replacement is necessary.

Westinghouse CHASSIS V-2184-4

TELEVISION RADIO

MODELS H-447T4, H-448T4 AND H-449T4

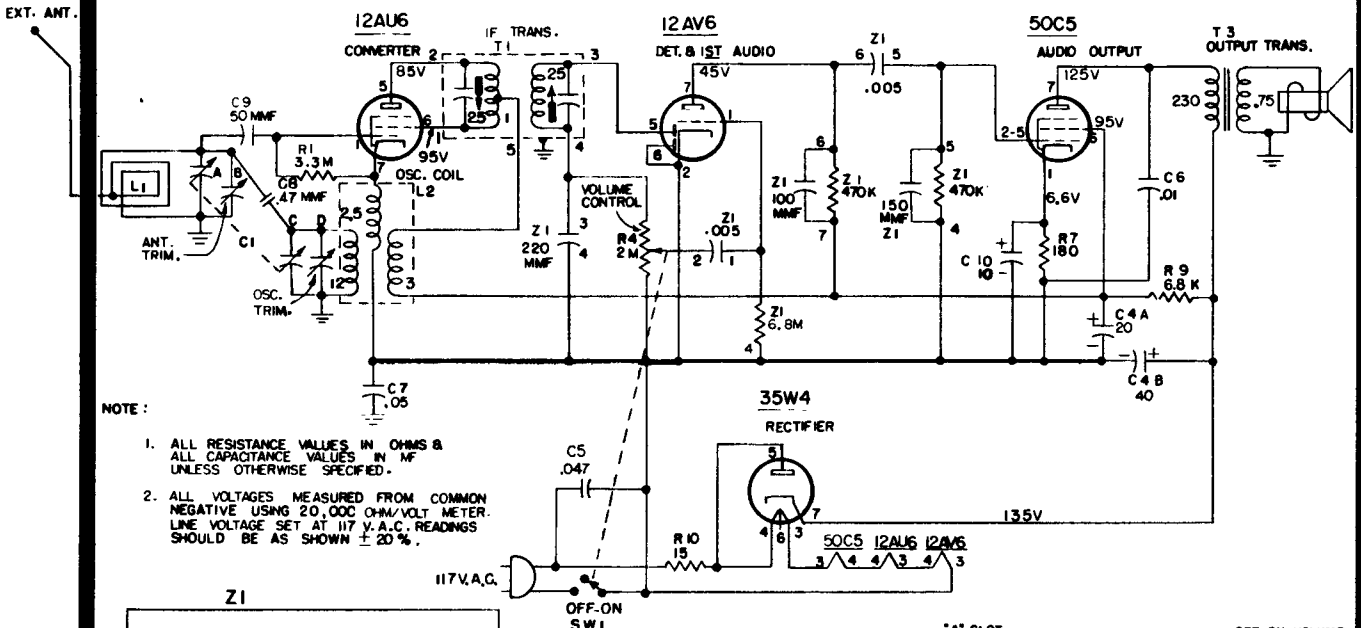

NOTE :

1. ALL RESISTANCE VALUES IN OHMS & ALL CAPACITANCE VALUES IN MF UNLESS OTHERWISE SPECIFIED.
2. ALL VOLTAGES MEASURED FROM COMMON NEGATIVE USING 20,000 OHM/VOLT METER. LINE VOLTAGE SET AT 117 V.A.C. READINGS SHOULD BE AS SHOWN $\pm 20\%$.

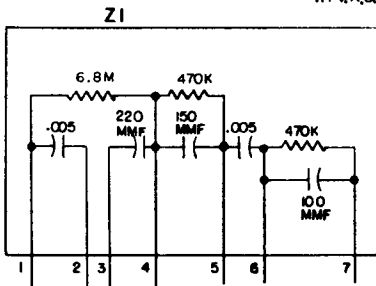

REMOVING COVER With the right hand, insert a screwdriver into the slot marked "A" (see Fig 2). With the left hand, grasp the chassis so that the thumb is on the speaker magnet and the second finger is pressing forward slightly on the tab (see Fig. 2). Then with a slight turn of the screwdriver the bottom cover will unlock from the chassis.

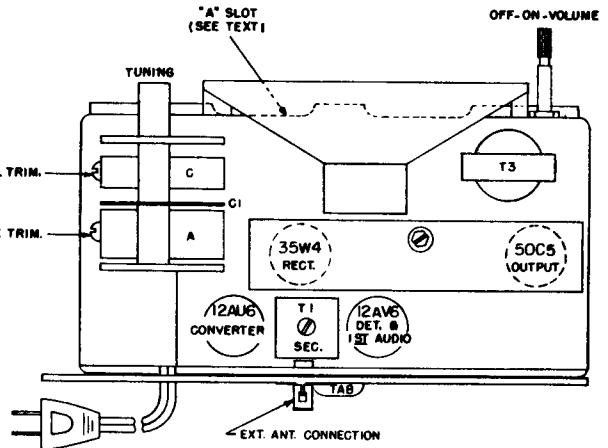

FIG 2 Chassis Layout

ALIGNMENT

While making the following adjustments, keep the volume control set for maximum output and the signal generator output attenuated to avoid AVC action.

Step	Connect Signal Generator to -	Signal Generator Frequency	Radio Dial	Adjust for Maximum Output -
1	Stator of ant. tuning capacitor (A) through a 200 mmf capacitor	455 kc.	Minimum capacity	Bottom and top slugs of T1 *
2	Same as step 1	1625 kc.	Minimum capacity	Oscillator trimmer (D)
3	Radiated signal	1400 kc.	1400 kc.	Antenna trimmer (B)

* It is recommended that a fiber aligning tool that snugly fits the slot in the powdered iron core be used to prevent chipping of the slot.

Westinghouse CHASSIS V-2185-2

Models H-494P4, H-495P4, H-496P4

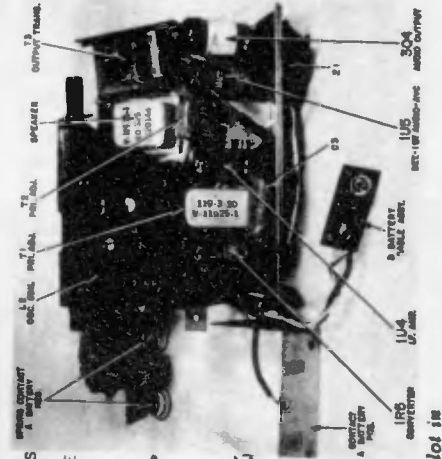
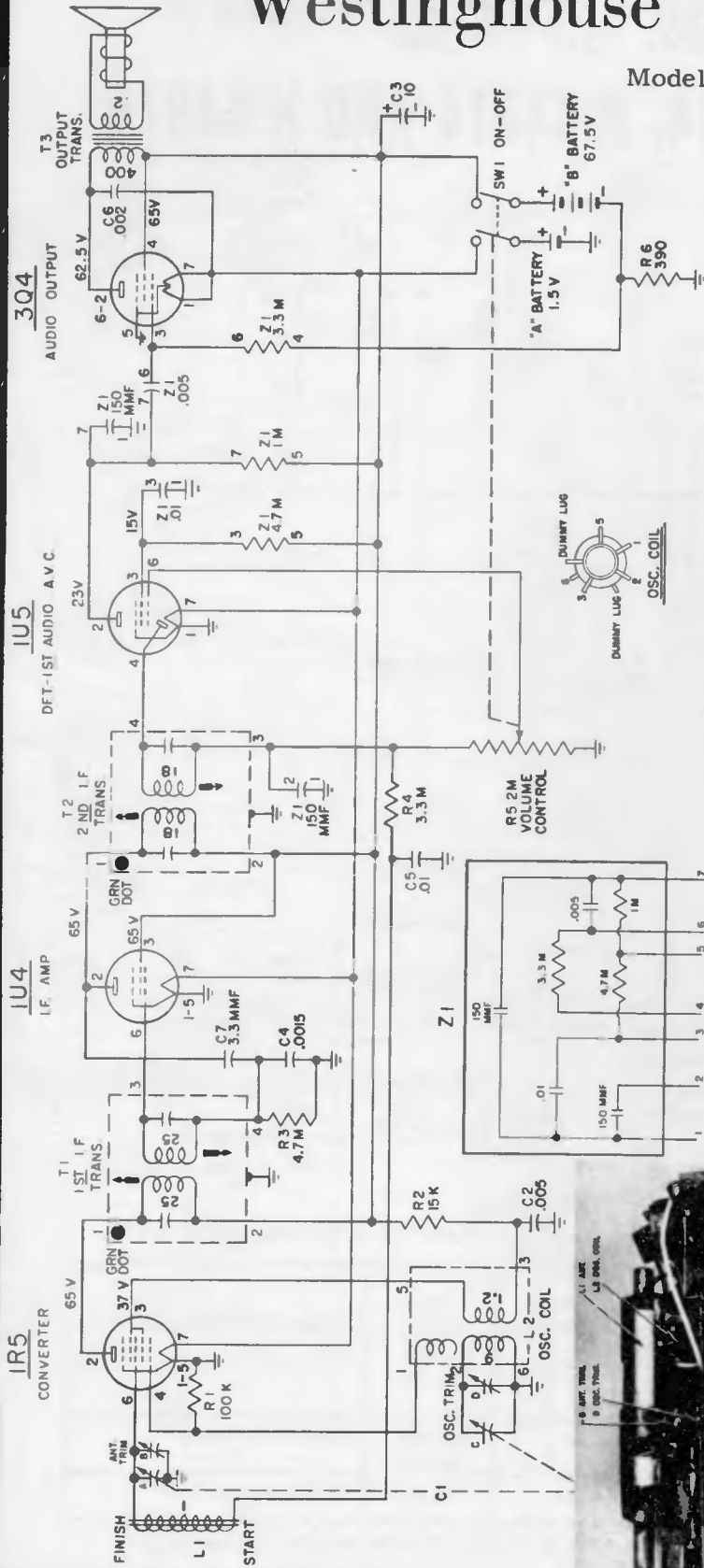

ALL CAPACITANCE VALUES IN MFD. AND ALL RESISTANCE VALUES IN OHMS UNLESS OTHERWISE SPECIFIED.
ALL VOLTAGES MEASURED FROM CHASSIS (GND) USING A V.T.V.M. VOLUME MINIMUM. TUNING OFF STATION

ALIGNMENT

Step	Connect Signal Generator to —	Signal Generator Frequency	Radio Dial	Adjust for Maximum Output —
1	Stator of RF section of tuning capacitor C1 through a .01 mfd capacitor	455 kc.	Minimum capacity	Top and bottom slugs of 2nd and 1st IF transformers in order given, SEE NOTE.
2	Radiated signal	1625 kc.	1625 kc.	Osc. trimmer "D"
3	Radiated signal	1400 kc.	1400 kc.	Ant. trimmer "B"
4	Repeat steps 2 and 3			

NOTE: When adjusting the IF transformers, it is recommended that a fiber aligning tool which snugly fits the slot in the powdered iron core be used to prevent chipping of the slot.

TO REMOVE BACK COVER — Insert the edge of a coin into the slot in the top of the cabinet, and twist the coin.

MANUAL OF 1955 MOST-OFTEN-NEEDED RADIO DIAGRAMS

Westinghouse CHASSIS V-2189-4

Models H-443T5, H-444T5, -A, H-445T5, -A, H-446T5, -A

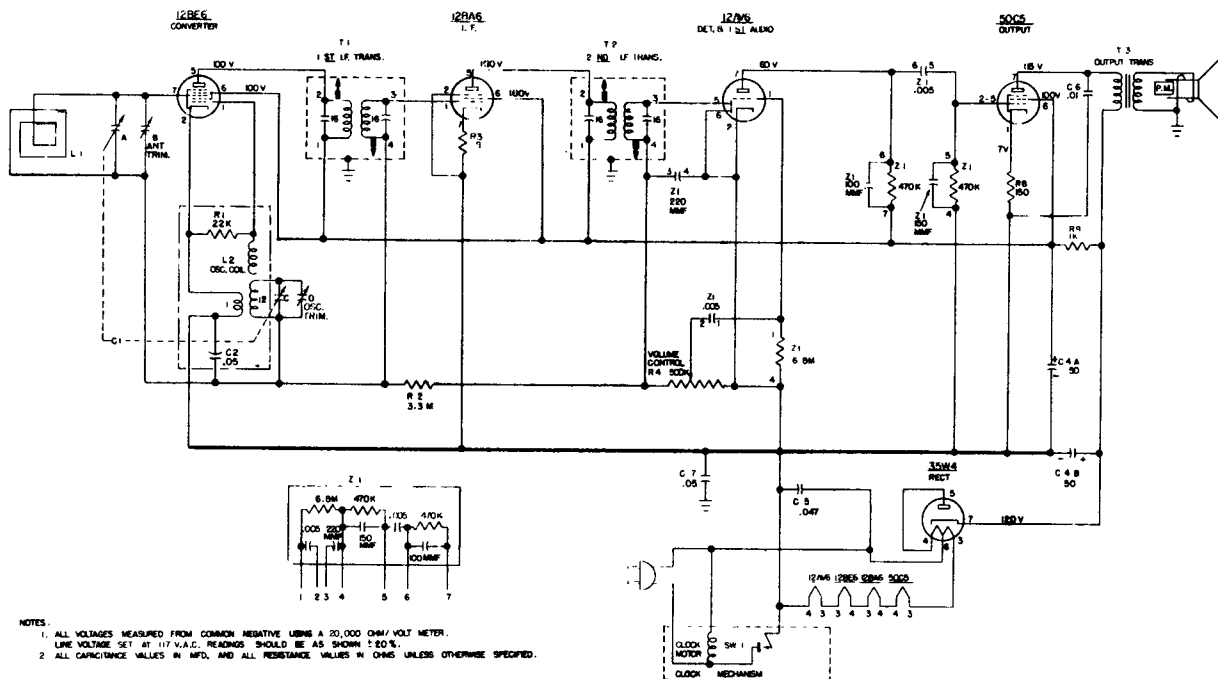

NOTES:
 1. ALL VOLTAGES MEASURED FROM COMMON NEGATIVE USING A 20,000 OHM/VOLT METER.
 LINE VOLTAGE SET AT 117 V.A.C., READINGS SHOULD BE AS SHOWN ± 20%.
 2. ALL CAPACITANCE VALUES IN MFD., AND ALL RESISTANCE VALUES IN OHMS UNLESS OTHERWISE SPECIFIED.

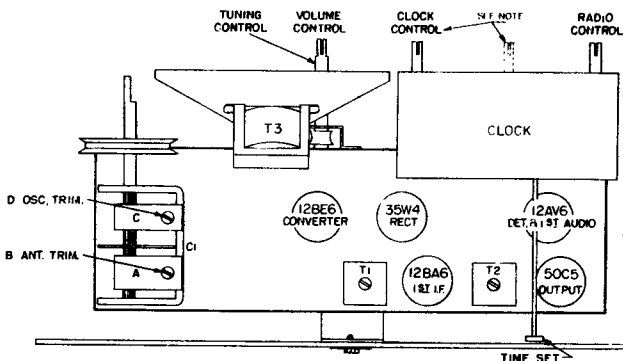

NOTE: SOME CHASSIS WILL INCLUDE CLOCKS USING THREE KNOBS: LABELED AS FOLLOWS: ALARM CONTROL, SLEEP CONTROL, AND RADIO CONTROL.

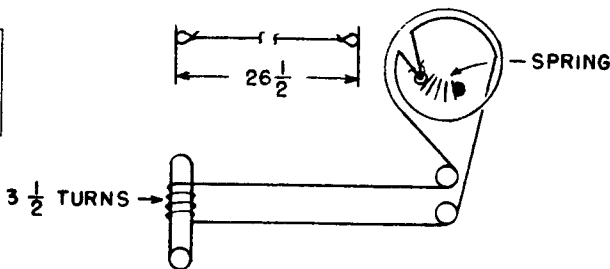

ALIGNMENT

It is recommended that the chassis be isolated from the power line by means of an isolation transformer.

While making the following adjustments, keep the volume control set for maximum output and the signal generator output attenuated to avoid AVC action.

Step	Connect Signal Generator to —	Signal Generator Frequency	Radio Dial	Adjust for Maximum Output —
1.	Stator of ant. tuning capacitor (A) through a 200 mmf capacitor	455 kc.	Minimum capacity	Top and bottom slugs of T2 and T1 in order given *
2.	Same as step 1	1625 kc.	Minimum capacity	Oscillator trimmer (D)
3.	Radisted signal	1400 kc.	1400 kc.	Antenna trimmer (B)

* It is recommended that a fiber aligning tool that snugly fits the slot in the powered iron core be used to prevent chipping of the slot.

MANUAL OF 1955 MOST-OFTEN-NEEDED RADIO DIAGRAMS

Westinghouse CHASSIS ASSEMBLY V-2229-1

Also Chassis V-2229-2 and V-2229-3,

Models H-457T6, H-458T6, H-459T6, H-460T6,
H-465R6, H-466R6, H-467R6, H-468R6.

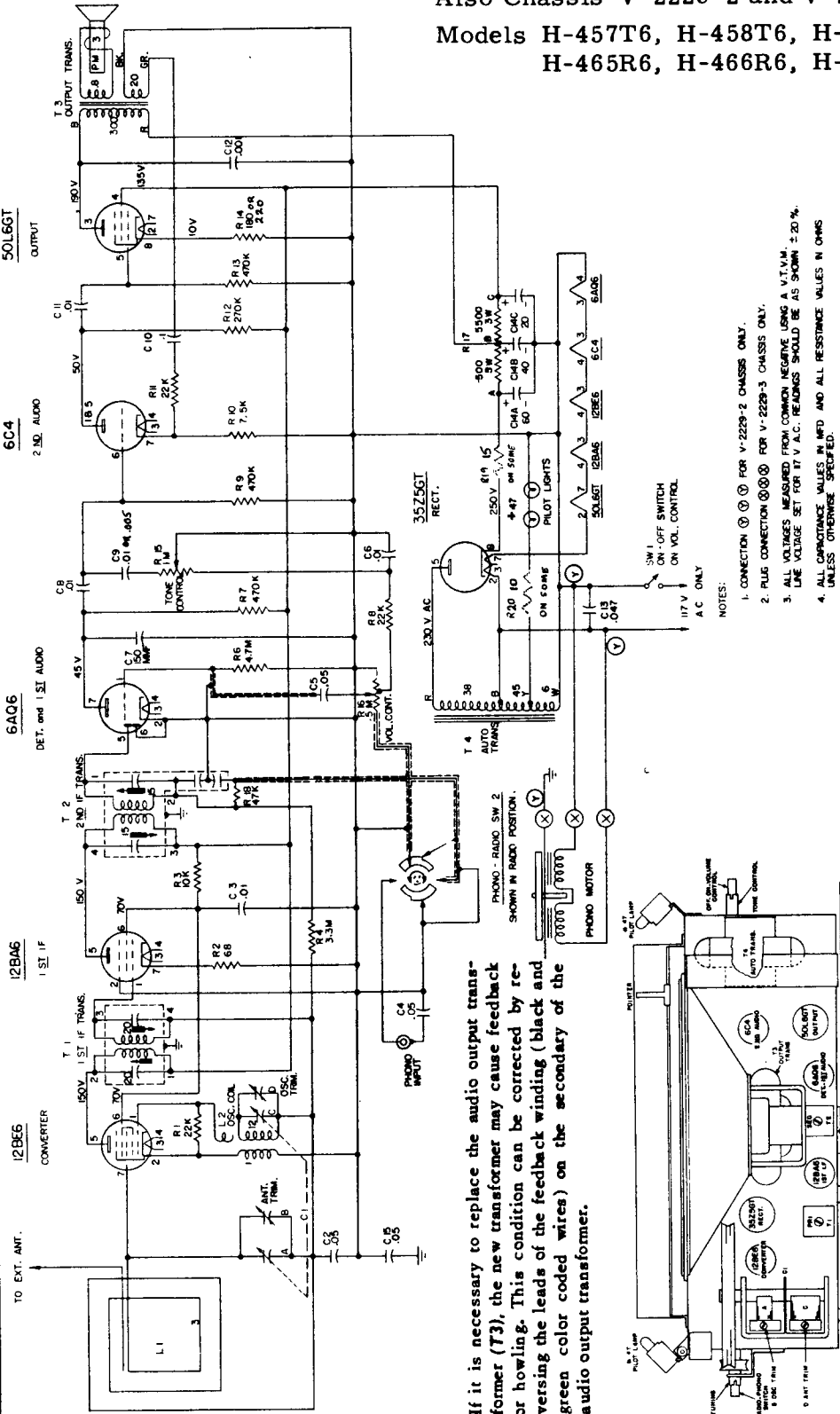

If it is necessary to replace the audio output transformer (T3), the new transformer may cause feedback or howling. This condition can be corrected by reversing the leads of the feedback winding (black and green color coded wires) on the secondary of the audio output transformer.

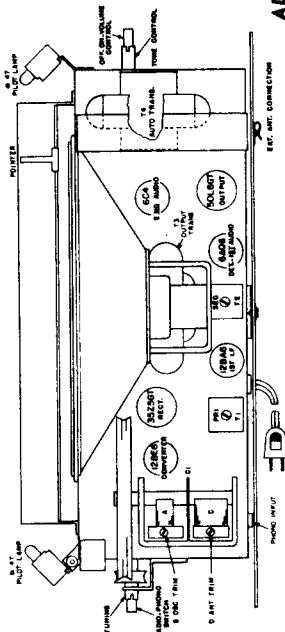

ALIGNMENT

Step	Connect Signal Generator to -	Signal Generator Frequency	Tuning Capacitor	Adjust for Maximum output
1	Stator of Ant. Tuning Capacitor (A) through A 200 mmf. capacitor	455KC	Minimum Capacity	Top and Bottom Slugs of T2 and T1 in given order*
2	Same as step 1	1,625KC	Minimum Capacity	Oscillator Trimmer (D)
3	Radiated Signal	1,400KC	1,400KC	Antenna Trimmer (B)

* It is recommended that a fiber aligning tool that snugly fits in the powdered iron core be used to prevent chipping of the slot.

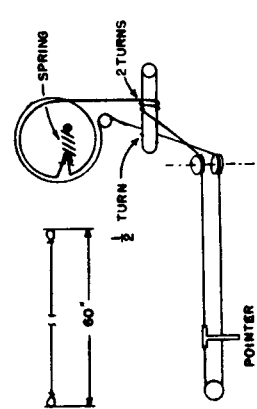

- NOTES:
1. CONNECTION Ⓢ Ⓣ FOR V-2229-2 CHASSIS ONLY.
 2. PLUG CONNECTION Ⓢ Ⓣ FOR V-2229-3 CHASSIS ONLY.
 3. ALL VOLTAGES MEASURED FROM COMMON NEGATIVE USING A V.T.V.M. LINE VOLTAGE SET FOR 117 V.A.C. READINGS SHOULD BE AS SHOWN ± 20%.
 4. ALL CAPACITANCE VALUES IN MFD AND ALL RESISTANCE VALUES IN OHMS UNLESS OTHERWISE SPECIFIED.

MANUAL OF 1955 MOST-OFTEN-NEEDED RADIO DIAGRAMS

Westinghouse

CHASSIS ASSEMBLY V-2234-1

Models H-490P4, H-491P4, H-492P4, H-493P4, H-508P4

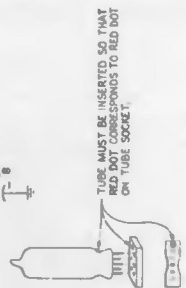
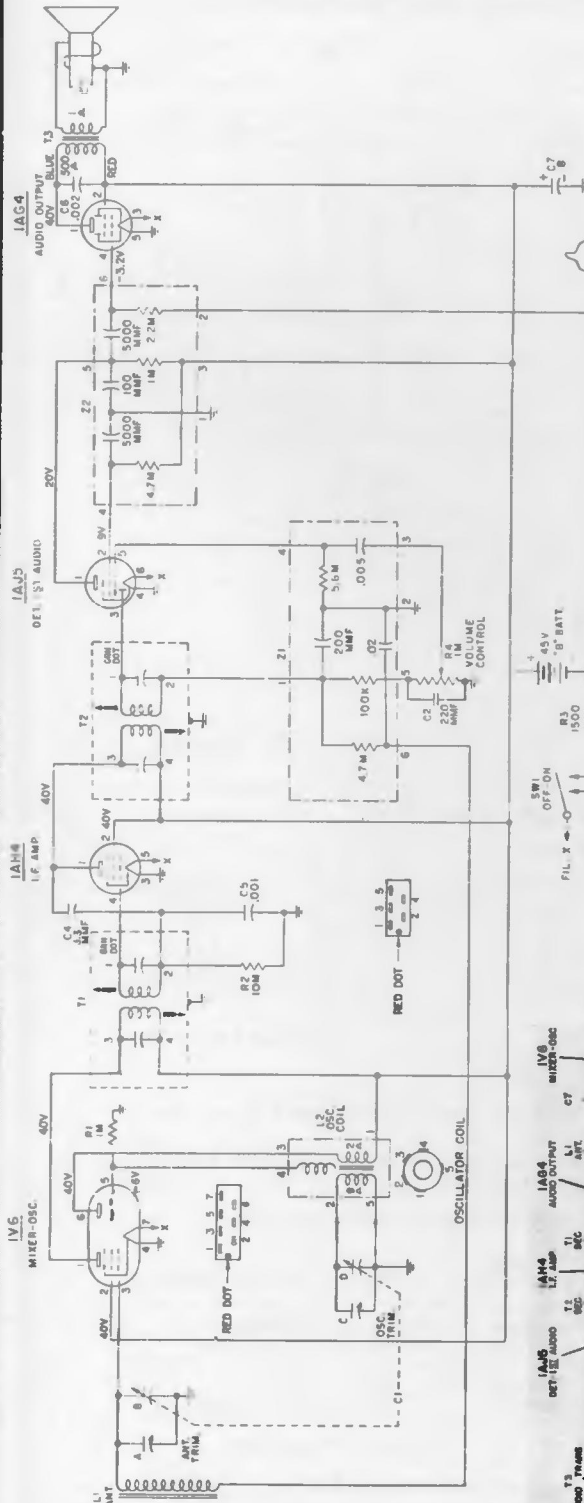

NOTES:
 1. ALL VOLTAGES MEASURED FROM COMMON NEGATIVE USING A VTVM ±20%.
 2. ALL CAPACITANCE VALUES IN MFD AND ALL RESISTANCE VALUES IN OHMS UNLESS OTHERWISE SPECIFIED.

ALIGNMENT

Before beginning alignment it is necessary to remove the two screws holding the loop antenna to the chassis. The loop antenna (L1) should be folded back in order to make the secondary of T1 and T2 accessible for alignment.

In order to make the primary of T1 and T2 accessible for alignment, it is necessary to remove the volume control knob.

While making the following adjustments, keep the volume control set for maximum output and the signal generator output attenuated to avoid AVC action.

STEP	CONNECT SIGNAL GENERATOR TO	SIGNAL GENERATOR FREQUENCY	RADIO DIAL	ADJUST FOR MAXIMUM OUTPUT
1	Stator of RF Section of Tuning Capacitor C1 Through a .01 mfd. Capacitor.	455 KC.	Minimum Capacity	Tap and bottom slugs of 2nd and 1st IF Transformers in Order Given.
2	Radiated Signal	1625 KC.	Minimum Capacity	Oscillator Trimmer "D" (Rock-in)
3	Radiated Signal	1425 KC.	1425 KC.	Antenna Trimmer "B"
4	Radiated Signal	600 KC.	600 KC.	Slug in oscillator coil (L2) (Rock-in)
5	Repeat Steps 2 and 3			

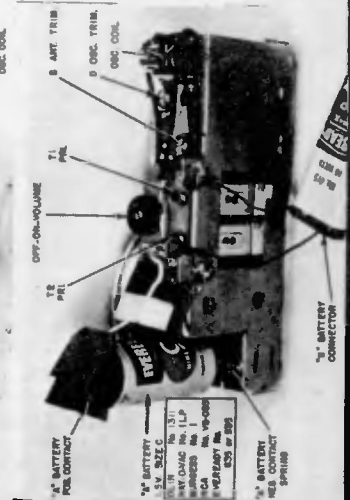
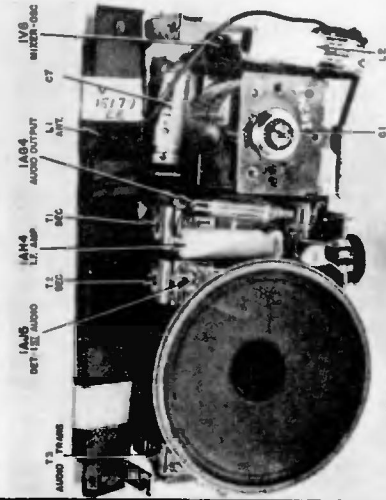

MANUAL OF 1955 MOST-OFTEN-NEEDED RADIO DIAGRAMS

Westinghouse

Chassis V-2236-2, Models H-486T5, H-487T5, H-488T5, and H-489T5.
 Chassis V-2236-1, Models H-475T5, H-476T5, H-477T5, and H-478T5
 are practically identical electrically to Chassis V-2236-2.

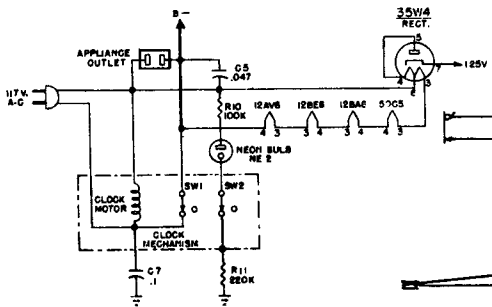
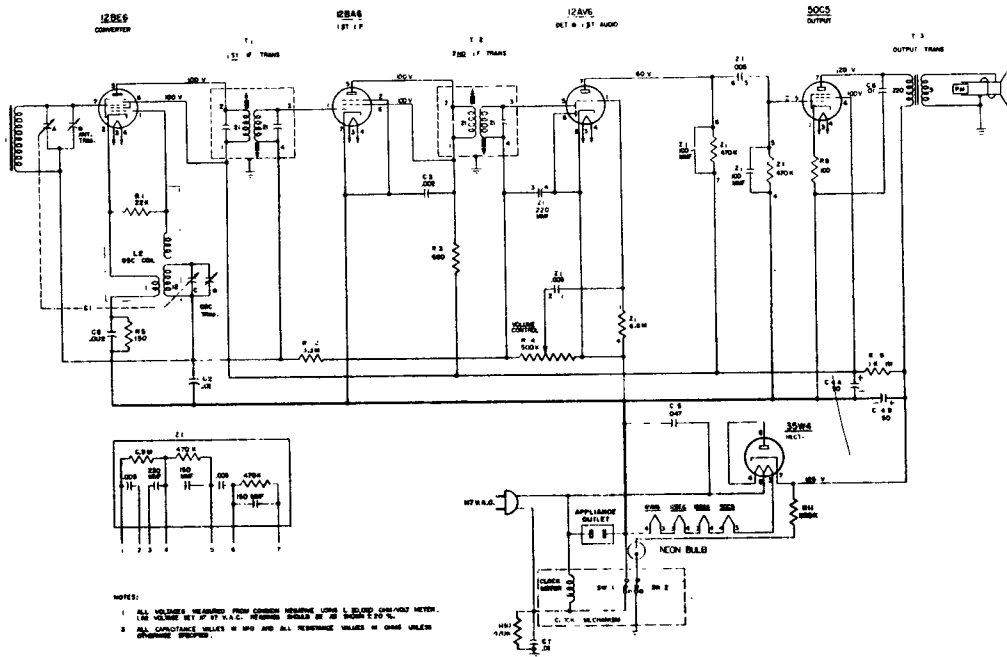

Filament Wiring

ALIGNMENT

It is recommended that the chassis be isolated from the power line by means of an isolation transformer.

While making the following adjustments, keep the volume control set for maximum output and the signal generator output attenuated to avoid AVC action.

Step	Connect Signal Generator to -	Signal Generator Frequency	Tuning Capacitor	Adjust for Maximum Output -
1	Stator of ant. tuning capacitor (A) through a 200 mf capacitor	455 kc.	Minimum capacity	Bottom and top slugs of T2 and T1 in order given*
2	Same as step 1	1625 kc.	Minimum capacity	Oscillator trimmer (D)
3	Radiated signal	1400 kc.	1400 kc.	Antenna trimmer (B)

*It is recommended that a fiber aligning tool that snugly fits the slot in the powdered iron core be used to prevent chipping of the slot.

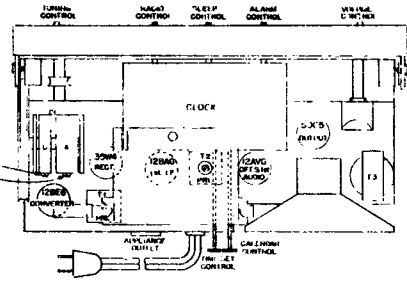

Chassis Layout

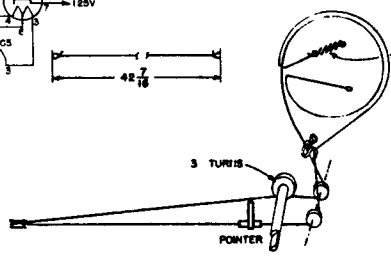

MANUAL OF 1955 MOST-OFTEN-NEEDED RADIO DIAGRAMS

Westinghouse Electric Corporation

CHASSIS V-2237-1

Models H-504P4, H-505P4, H-506P4, H-507P4

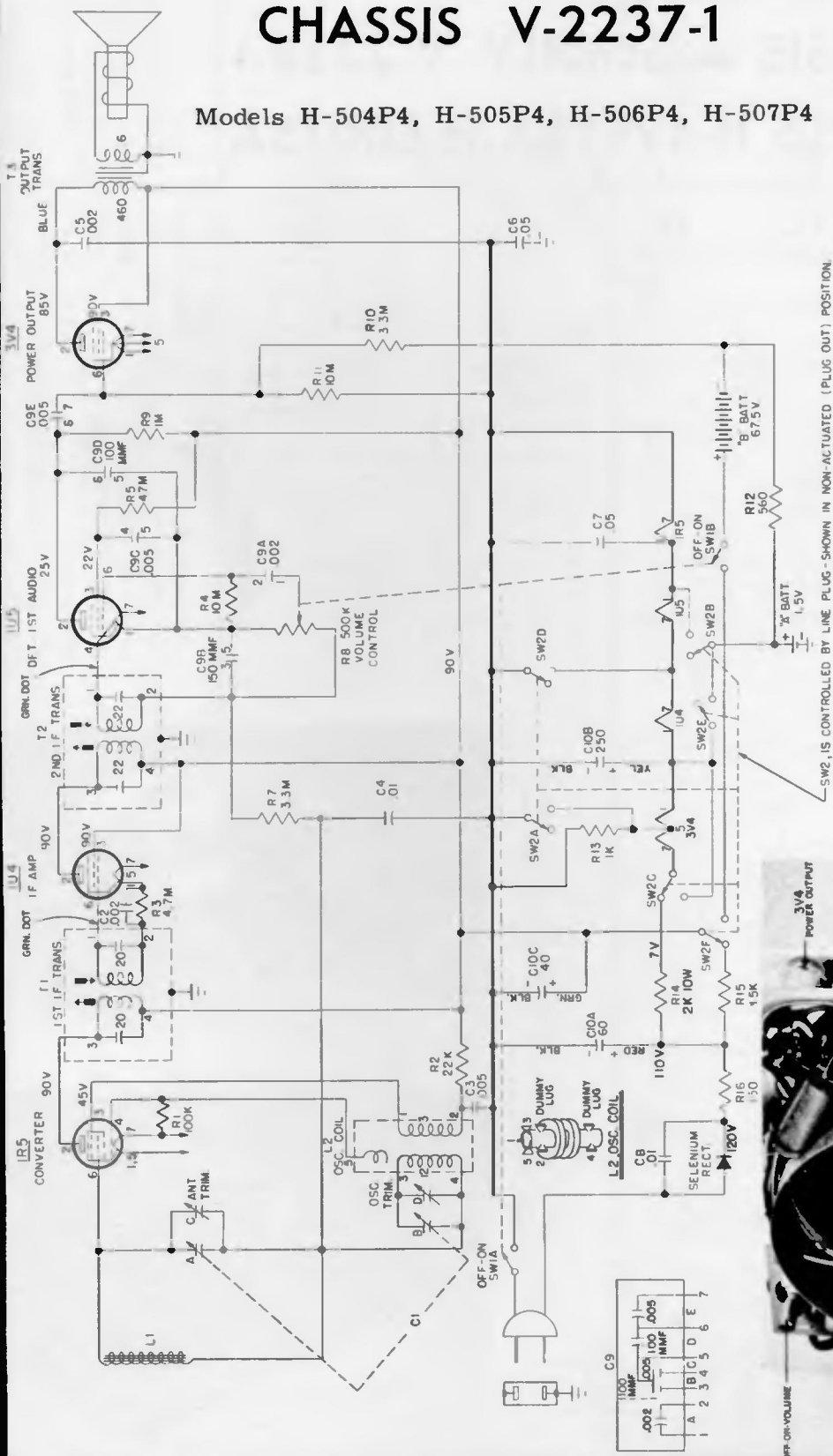

ALIGNMENT

Step	Connect Signal Generator -	Signal Generator Frequency	Radio Dial	Adjust for Maximum Output
1	Between Stator of R-F tuning capacitor (A), and (B), through a 0.1 mfd. capacitor	455 kc.	minimum capacity	Top and bottom slugs in 2nd and 1st I-F trans. in order given
2	Radiated Signal	1625 kc.	minimum capacity	Osc. trimmer (D)
3	Radiated Signal	1400 kc.	1400 kc.	Ant. trimmer (C)

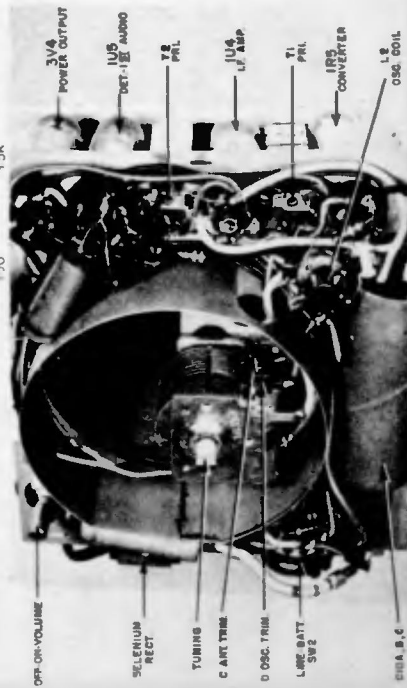

MANUAL OF 1955 MOST-OFTEN-NEEDED RADIO DIAGRAMS

Westinghouse CHASSIS ASSEMBLY V-2238-1 MODELS H-499T5A, H-500T5A

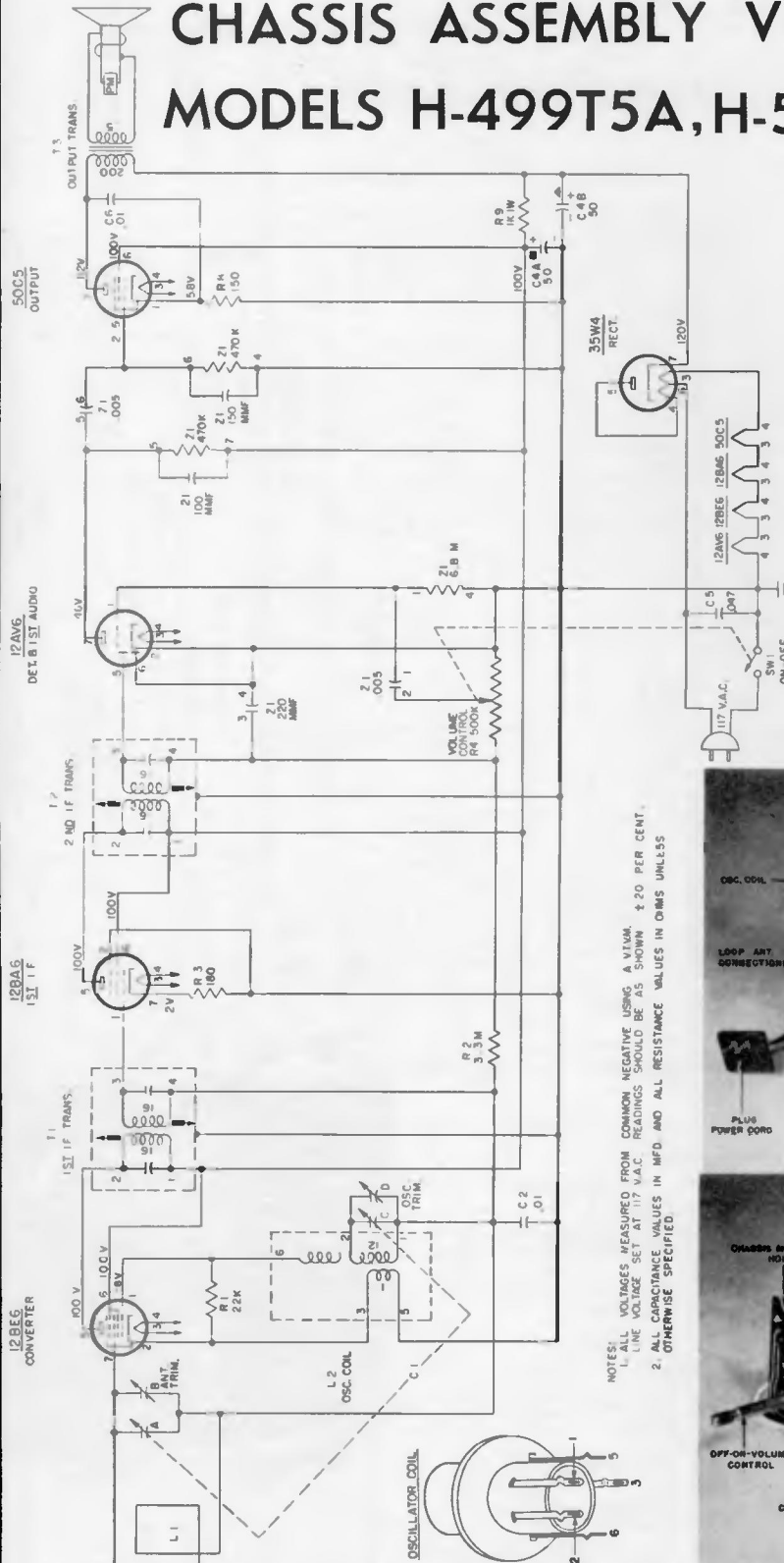

NOTES:
 1. ALL VOLTAGES MEASURED FROM COMMON NEGATIVE USING A V.I.M.A.
 LINE VOLTAGE SET AT 117 V.A.C. READINGS SHOULD BE AS SHOWN ± 20 PER CENT.
 2. ALL CAPACITANCE VALUES IN MFD AND ALL RESISTANCE VALUES IN OHMS UNLESS OTHERWISE SPECIFIED.

ALIGNMENT

Step	Connect Signal Generator to -	Signal Generator Frequency	Radio Dial	Adjust for Maximum Output
1.	Stator of ant. tuning capacitor (A) through a 200 mmf capacitor	455 kc.	Minimum capacity	Top and bottom slugs of T2 and T1 in order given
2.	Same as step 1	1625 kc.	Minimum capacity	Oscillator trimmer (D)
3.	Radiated signal	1400 kc.	1400 kc.	Antenna trimmer (B)

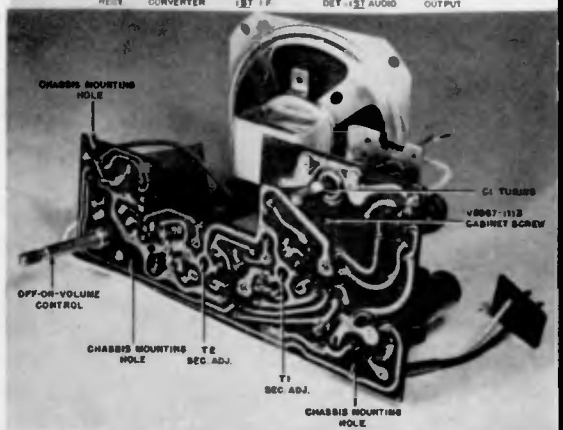
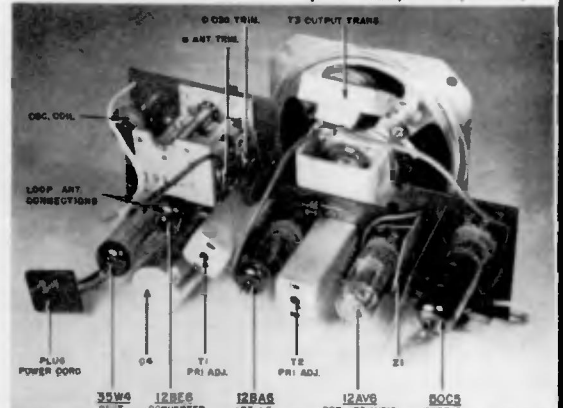

MANUAL OF 1955 MOST-OFTEN-NEEDED RADIO DIAGRAMS

ZENITH RADIO MODEL R510Z1, CHASSIS 5M02Z1

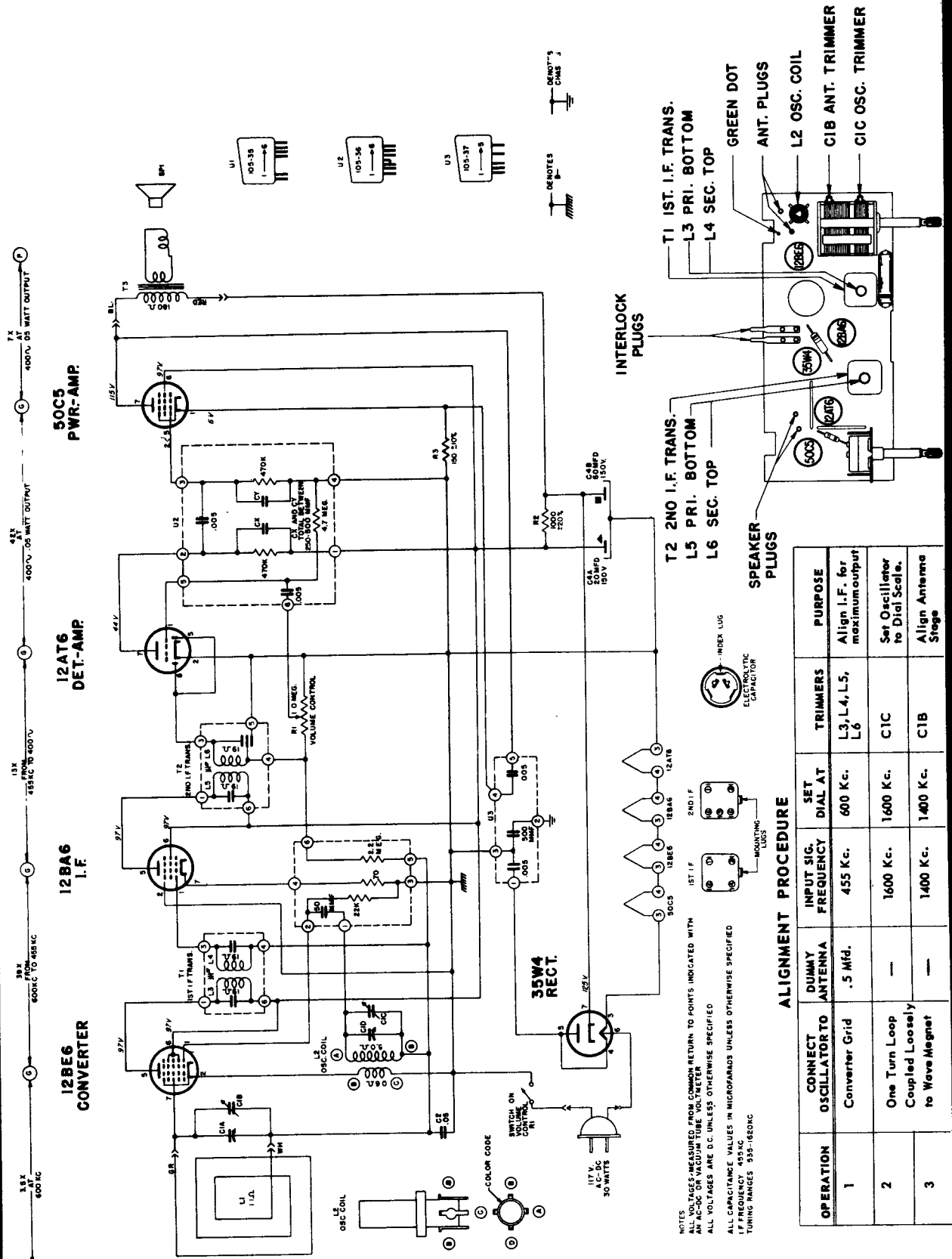

MANUAL OF 1955 MOST-OFTEN-NEEDED RADIO DIAGRAMS

ZENITH RADIO CORPORATION CHASSIS 5R01

MODELS R511R, R511W, R511F & R511V

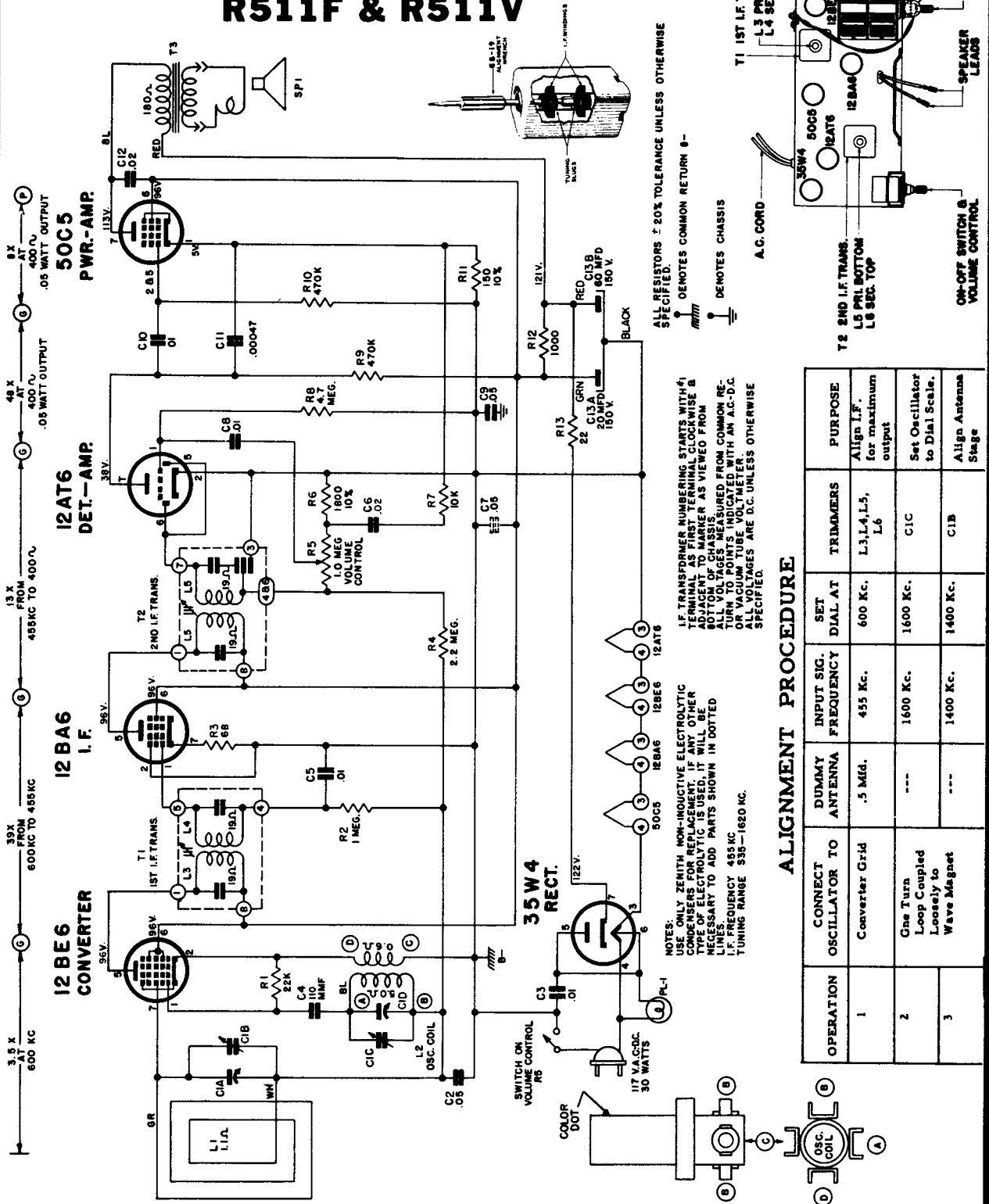

MANUAL OF 1955 MOST-OFTEN-NEEDED RADIO DIAGRAMS

ZENITH RADIO Chassis 5R07, Models R519R, W, and T522F, G, R, V, W.
 Chassis 5R03, Models R521F, G, R, W, Y, are electrically similar to 5R07, but have clock panel dimmer controls.

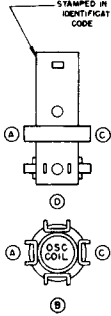
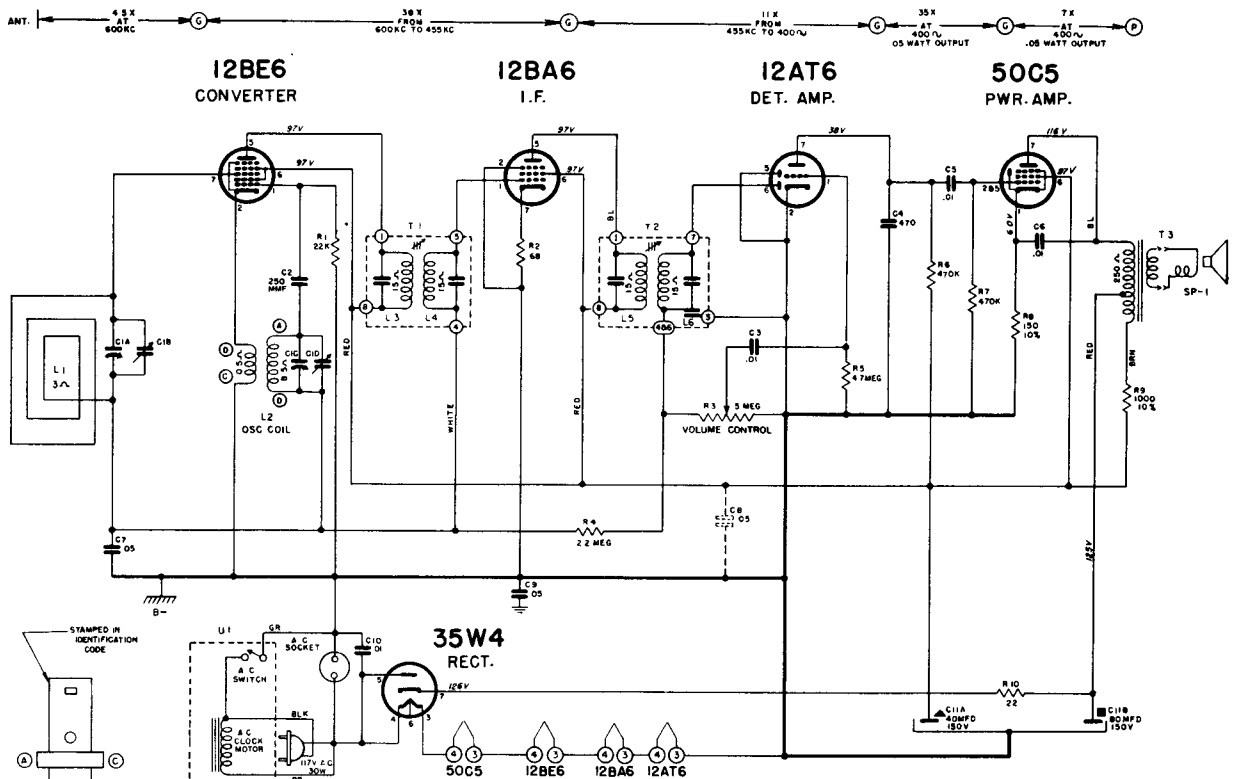

STAMPED IN IDENTIFICATION CODE
 A.C. CLOCK MOTOR
 110V. A.C. 30W.
 110V. A.C. 30W.
 110V. A.C. 30W.

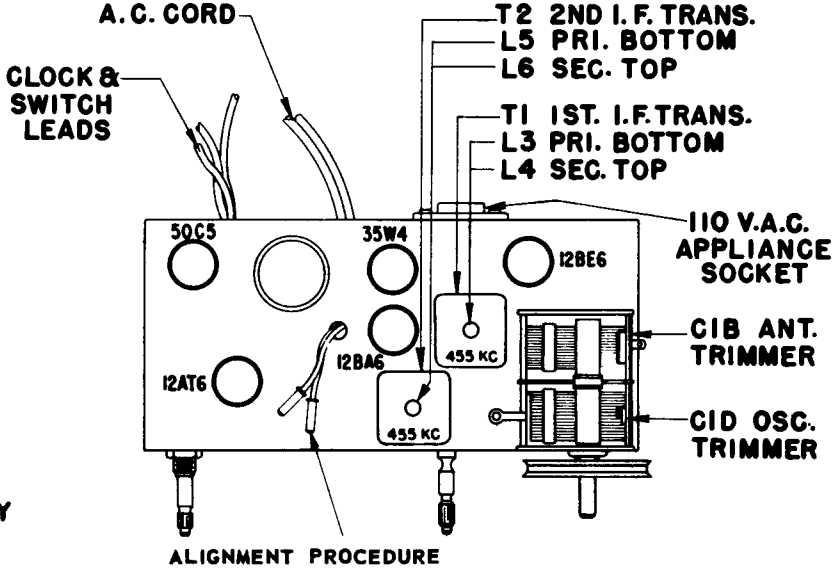
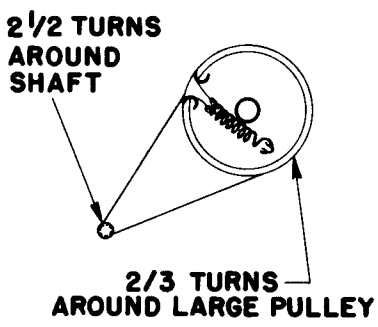

OPERATION	CONNECT OSCILLATOR TO	DUMMY ANTENNA	INPUT SIG. FREQUENCY	SET DIAL AT	TRIMMERS	PURPOSE
1	Converter Grid	.5 Mfd.	455 Kc.	600 Kc.	L3, 4, 5, 6	For I.F. Alignment
2	One Turn Loop Coupled Loosely to Wave Magnet	—	1600 Kc.	1600 Kc.	C1D	Set Oscillator to Dial Scale
3		—	1400 Kc.	1400 Kc.	C1B	Align Antenna Stage

MANUAL OF 1955 MOST-OFTEN-NEEDED RADIO DIAGRAMS

ZENITH RADIO CORPORATION CHASSIS 5R10

MODELS R512F, R512R, R512V & R512W

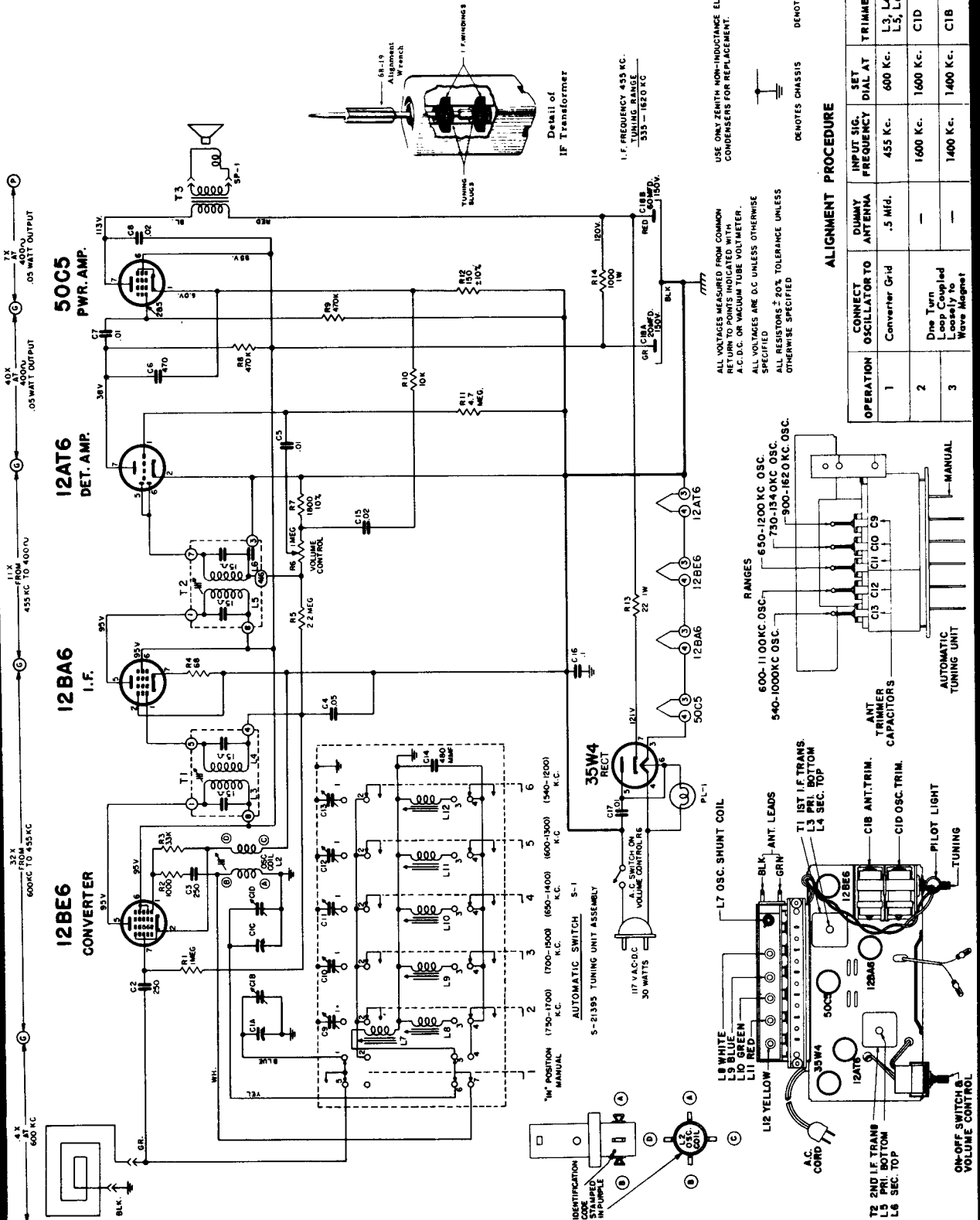

ZENITH RADIO CORP.

MODELS HFR20E & HFR21R CHASSIS 5R20

6V6GT
POWER AMP.

1/2 12AT7

6J5

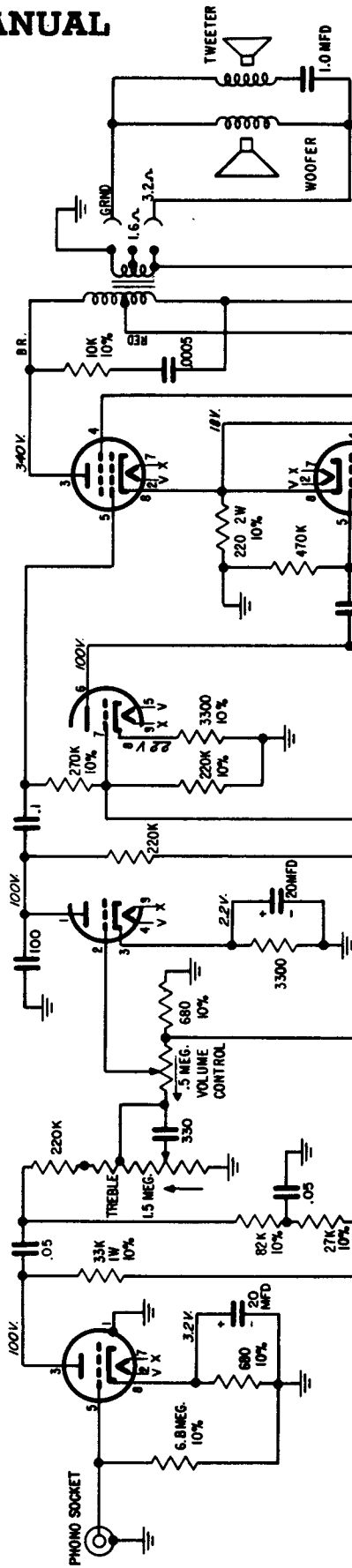

6V6GT
POWER AMP.

5Y3GT

SWITCH ON
VOLUME CONTROL

F1 1.5 AMP

PHONO A.C.
(117)

117V A.C.
63WATTS

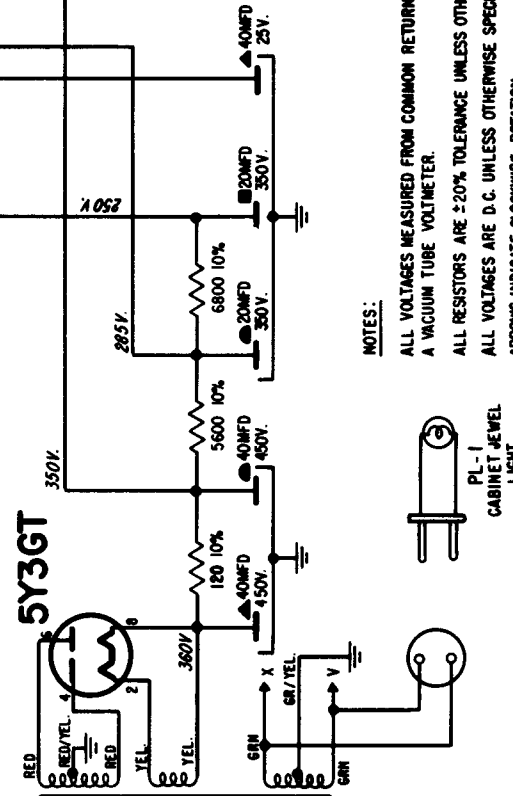

NOTES:
 ALL VOLTAGES MEASURED FROM COMMON RETURN TO POINTS INDICATED WITH A VACUUM TUBE VOLTMETER.
 ALL RESISTORS ARE ±20% TOLERANCE UNLESS OTHERWISE SPECIFIED.
 ALL VOLTAGES ARE D.C. UNLESS OTHERWISE SPECIFIED.
 ARROWS INDICATE CLOCKWISE ROTATION.

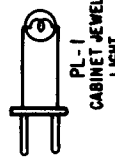

MANUAL OF 1955 MOST-OFTEN-NEEDED RADIO DIAGRAMS

ZENITH RADIO CORP.

MODELS R623, F, R, W, Y

CHASSIS 6R03

NOTES:
 ALL VOLTAGES MEASURED FROM COMMON RETURN TO POINTS INDICATED WITH AN A.C. D.C. OR VACUUM TUBE VOLT-METER.
 ALL VOLTAGES ARE D.C. UNLESS OTHERWISE SPECIFIED.
 ALL RESISTORS ± 20% TOLERANCE UNLESS OTHERWISE SPECIFIED.
 RADIO-PHONO SWITCH SHOWN IN PHONO POSITION.
 USE ONLY ZENITH NON-INDUCTIVE ELECTROLYTIC CONDENSERS FOR REPLACEMENT.
 IF ANY OTHER TYPE OF ELECTROLYTIC IS USED IT WILL BE NECESSARY TO ADD C11 SHOWN IN DOTTED LINES.
 I.F. TRANSFORMER NUMBERING STARTS WITH #1 TERMINAL AS FIRST TERMINAL CLOCKWISE AND ADJACENT TO MARKER AS VIEWED FROM BOTTOM OF CHASSIS.

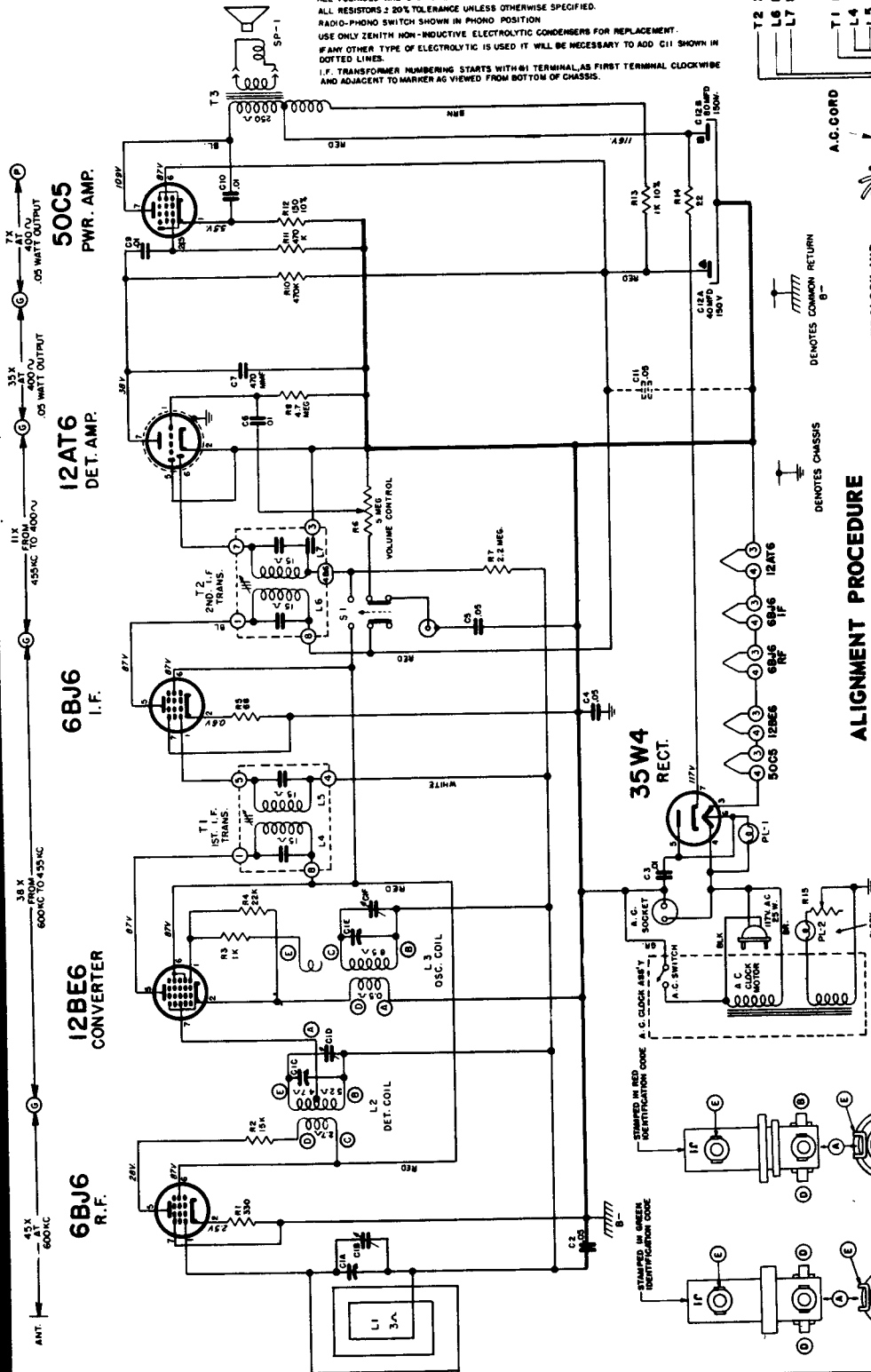

ALIGNMENT PROCEDURE

OPERATION	CONNECT OSCILLATOR TO	DUMMY ANTENNA	INPUT SIG. FREQUENCY	SET DIAL AT	TRIMMERS
1	Converter Grid	.5 Mfd.	455 Kc.	600 Kc.	L4, L5, L6, L7
2	One Turn Loop Coupled Loosely to Wave Magnet	—	1600 Kc.	1600 Kc.	C1F
3		—	1400 Kc.	1400 Kc.	C1D
4		—	1400 Kc.	1400 Kc.	C1B

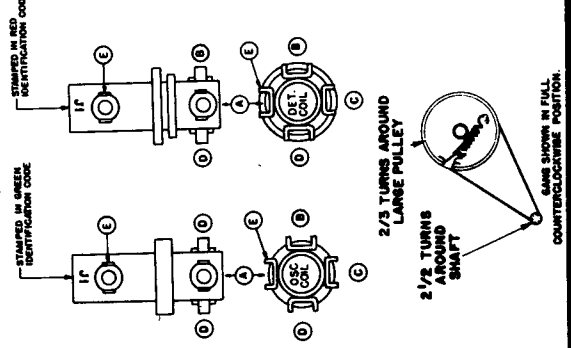

2 1/2 TURNS AROUND LANGE PULLEY
 2/3 TURNS AROUND SMART
 SAME SHOWN IN FULL COUNTERCLOCKWISE POSITION.

CLOCK AND SWITCH LEADS

ALIGNMENT PROCEDURE

DENOTES CHASSIS

DENOTES COMMON RETURN

T2 2ND. I.F. TRANS.
 L6 PRI. BOTTOM
 L7 SEC. TOP

T1 1ST. I.F. TRANS.
 L4 PRI. BOTTOM
 L5 SEC. TOP

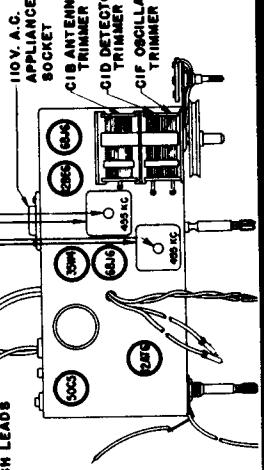

MANUAL OF 1955 MOST-OFTEN-NEEDED RADIO DIAGRAMS

ZENITH RADIO CORP.

Models T825F, G, and R, Chassis 8T01

(See next page at right for alignment information)

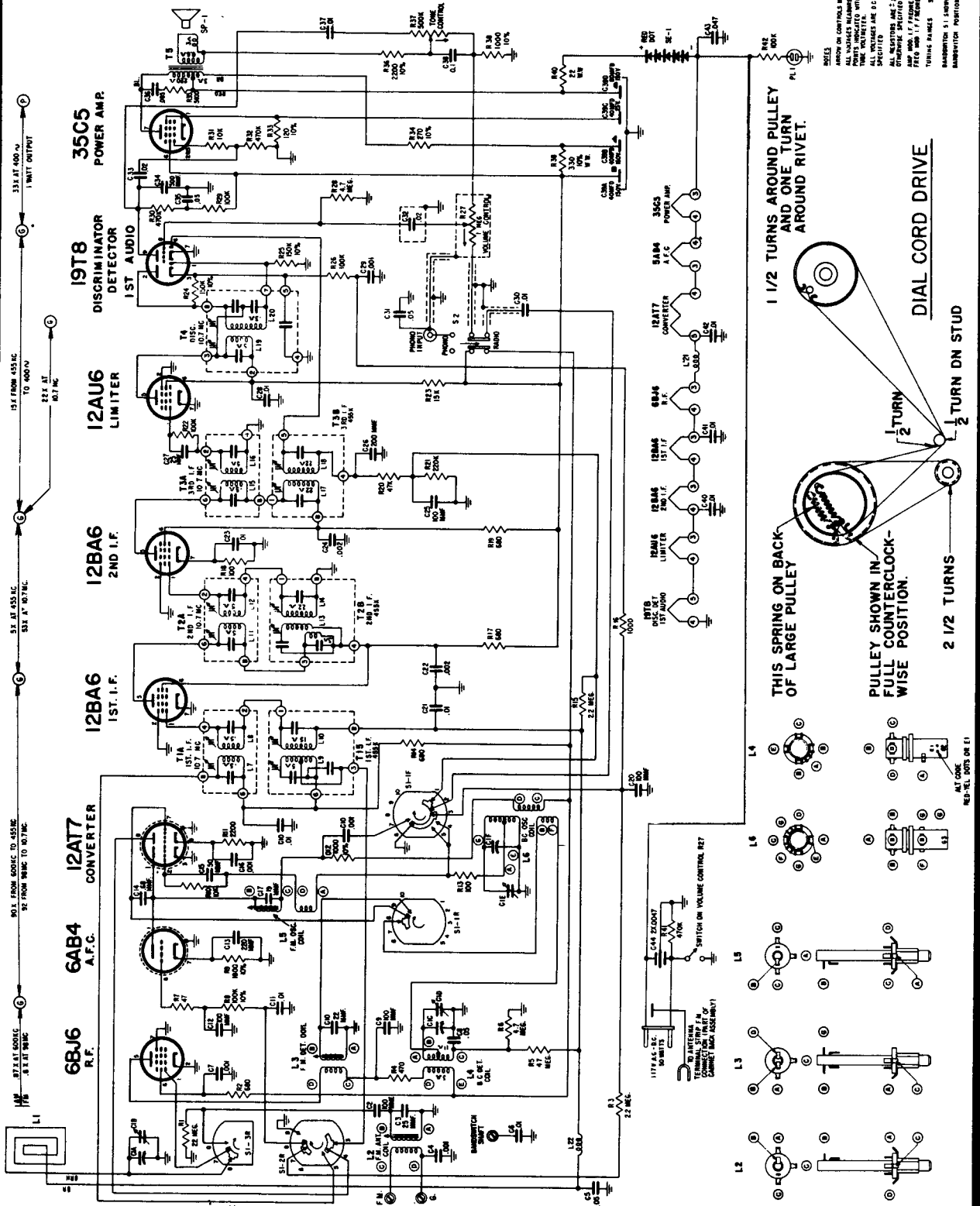

NOTES:
 ARROW ON CONTROLS INDICATES CLOCKWISE ROTATION.
 ALL WASHERS REMAINED FROM CONSOLE RETURN TO THIS POSITION.
 ALL WASHERS TO BE INSTALLED WITH #1-8 - 3/16" OR TIGHTER.
 ALL SPECIFIED ARE DC UNLESS OTHERWISE SPECIFIED.
 DIMENSIONS ARE IN INCHES UNLESS OTHERWISE SPECIFIED.
 AMP. WIND. I.F. FREQUENCY 455 KC.
 TUNING RANGE 540 - 1600 KC.
 TRANSMITTER 515 WATTS IN 518 KC. PORTION.
 SUBSTITUTION POSITIONS: 1. 2. 3. 4. 5. 6. 7. 8. 9. 10. 11. 12. 13. 14. 15. 16. 17. 18. 19. 20. 21. 22. 23. 24. 25. 26. 27. 28. 29. 30. 31. 32. 33. 34. 35. 36. 37. 38. 39. 40. 41. 42. 43. 44. 45. 46. 47. 48. 49. 50. 51. 52. 53. 54. 55. 56. 57. 58. 59. 60. 61. 62. 63. 64. 65. 66. 67. 68. 69. 70. 71. 72. 73. 74. 75. 76. 77. 78. 79. 80. 81. 82. 83. 84. 85. 86. 87. 88. 89. 90. 91. 92. 93. 94. 95. 96. 97. 98. 99. 100.

MANUAL OF 1955 MOST-OFTEN-NEEDED RADIO DIAGRAMS

ZENITH RADIO Models T825F, G, and R, Chassis 8T01,

—The signal generator output should be kept just high enough to get an indication on the meter.

- Vacuum Tube Voltmeter Lug 7 on discriminator transformer to chassis (half discriminator load).
- Vacuum Tube Voltmeter Lug 5 on discriminator transformer to chassis (full discriminator load).
- Vacuum Tube Voltmeter from Limiter Grid to Chassis.
- Loosen Slugs by applying a hot iron to the cement.

Alignment Information
(Continued)

ALIGNMENT PROCEDURE

OPERATION	CONNECT OSCILLATOR TO	DUMMY ANTENNA	INPUT SIGNAL FREQUENCY	BAND	SET DIAL TO	ADJ. TRIMMERS	PURPOSE
1	Pin 7 12AT7 Converter	.05 Mfd.	455 Kc Modulated	BC	600 Kc	L-9, 10, 13, 14, 17 and 18.	Align I.F. channel for maximum output
2	2 turns loosely coupled to wavemagnet		1600 Kc Modulated	BC	1600 Kc	C1E	Set Oscillator to dial scale
3	2 turns loosely coupled to wavemagnet		1400 Kc Modulated	BC	1400 Kc	C1D and C1B	Align det. and ant. stages
4	IMPORTANT: Before attempting to align the FM portion of this receiver, the Band Switch must be in PM POSITION.						
5 (a)	Pin 1 (grid) on 12AU6 limiter	.05 Mfd.	10.7 Mc Unmodulated	FM 100		L-20 coil slug Primary discr.	Align primary of discriminator for maximum reading
6 (b)	Pin 1 (grid) on 12AU6 limiter	.05 Mfd.	10.7 Mc Unmodulated	FM 100		L-19 coil slug sec. of discr.	Adjust secondary of discriminator for zero reading
7 (c)	Pin 1 (grid) on 12BA6 2nd. IF.	.05 Mfd.	10.7 Mc Unmodulated	FM 100		L-15 and L-16 Pri. and Sec. of 3rd IF transformer	Align 3rd. IF transformer for maximum reading
8 (c)	Pin 1 (grid) on 12BA6 1st. IF.	.05 Mfd.	10.7 Mc Unmodulated	FM 100		L-11 and L-12 Pri. and Sec. of 2nd IF transformer	Align 2nd. IF transformer for maximum reading
9 (c)	Pin 7 (grid) on 12AT7 converter tube socket	.05 Mfd.	10.7 Mc Unmodulated	FM 100		L-7 and L-8 Pri. and Sec. of 1st IF transformer	Align 1st. IF transformer for maximum reading
10 (c)	REPEAT STEPS 7, 8 AND 9						
11 (c) (d)	Antenna Post F (Remove line ant.)	270 Ohms	98 Mc Unmodulated	FM 100	98 Mc.	L-5 Osc. Coil Slug	Set Oscillator to dial scale
12 (c) (d)		270 Ohms	98 Mc Unmodulated	FM 100	98 Mc.	L-3 and L-2 Det. and RF coil Slugs	Align det. and ant. stages to maximum reading

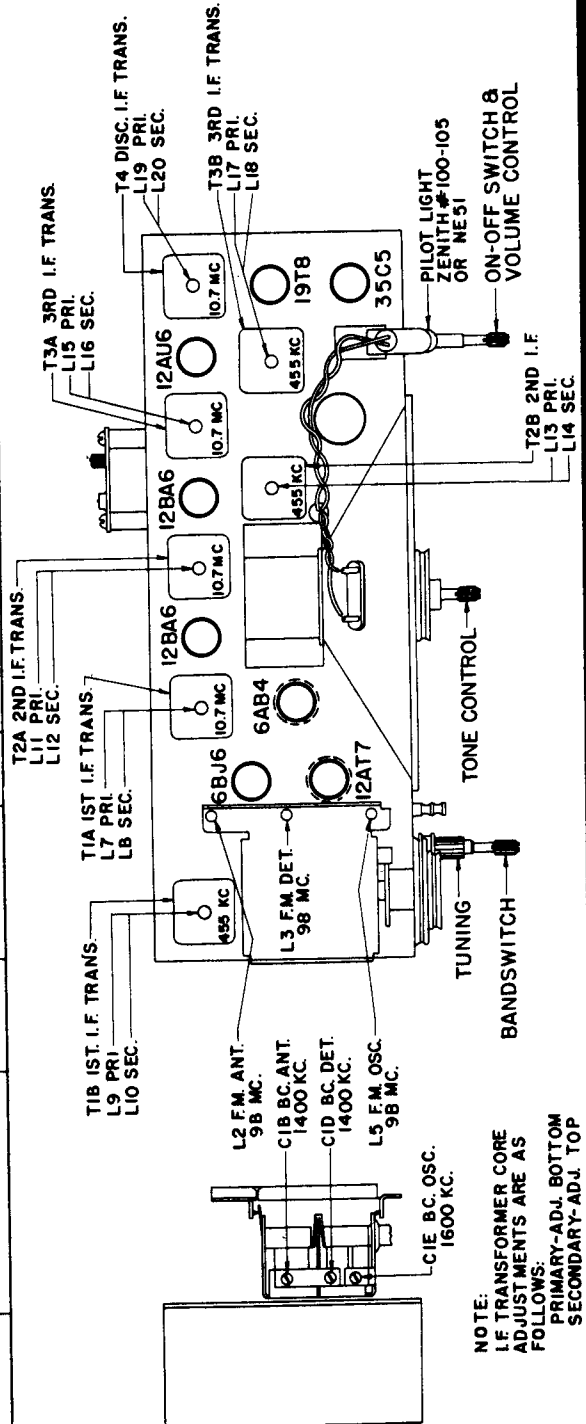

MANUAL OF 1955 MOST-OFTEN-NEEDED RADIO DIAGRAMS

ZENITH RADIO CORPORATION

MODEL T402Y, F & V CHASSIS 4T42

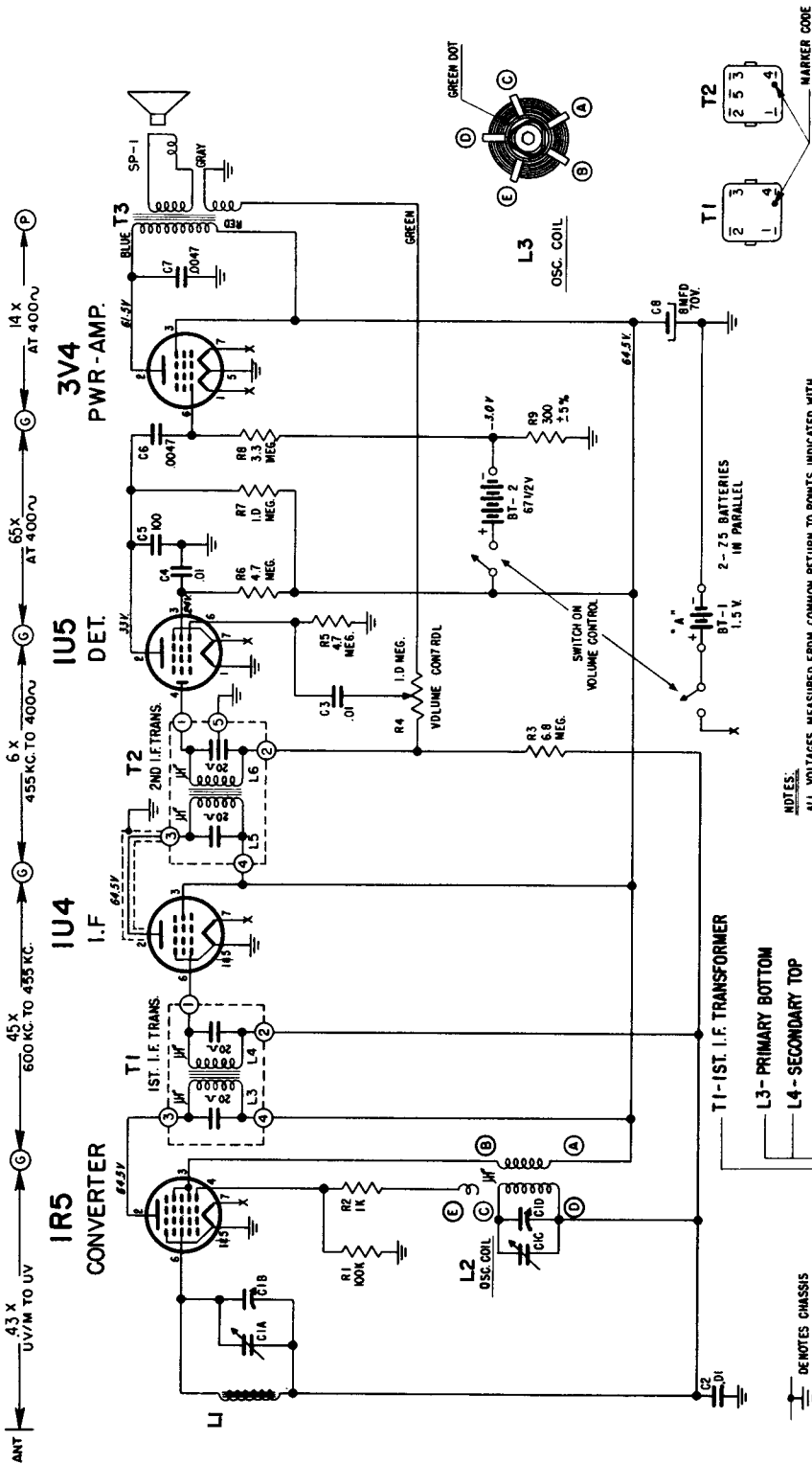

NOTES:
 ALL VOLTAGES MEASURED FROM COMMON RETURN TO POINTS INDICATED WITH A D.C. VACUUM TUBE VOLTMETER.
 ALL RESISTORS ±20% TOLERANCE UNLESS OTHERWISE SPECIFIED.
 I.F. FREQUENCY 455 KC. TUNING RANGE 540-1820 KC. STANDARD BC.

ALIGNMENT PROCEDURE

OPERATION	CONNECT OSCILLATOR TO	INPUT SIG. FREQUENCY	SET DIAL AT	TRIMMERS	PURPOSE
1	Converter Grid	455 Kc.	600 Kc.	L3, 4, 5, 6	For I.F. Alignment
2	Single Turn Loosely Coupled to Wavemagnet	1600 Kc.	1600 Kc.	C1B	Set Oscillator to Dial Scale
3		1400 Kc.	1400 Kc.	C1A	Antenna Alignment

