

Most - Often - Needed

1956

VOLUME 16

RADIO
DIAGRAMS

and Servicing Information

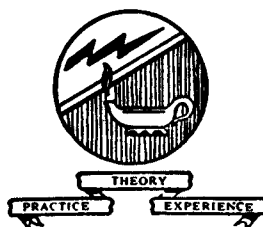

Compiled by
M. N. BEITMAN

Supreme Publications

Supreme Publications

1760 Balsam Road, Highland Park, Illinois
(Warehouse and Branch Office in Chicago, Illinois)

RADIO DIAGRAM MANUALS

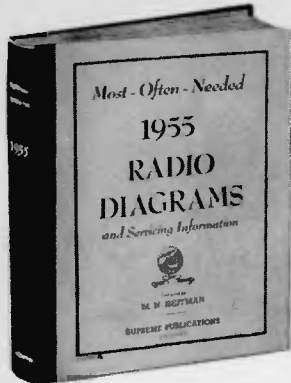

New 1955 VOLUME 15
Price \$2

Repair quickly all new 1955 sets as well as older radios. This big volume contains clearly printed, large schematics, needed alignment data, replacement parts lists, voltage values, and information on stage gain, location of trimmers, and dial stringing, for all important new 1955 sets. Includes material on portables, clock radios, record changers, FM, and auto sets. A worthy companion to fourteen previous volumes used by over 143,000 shrewd radio servicemen. Large size: 8½ x 11 inches. Manual style binding. Postpaid, only \$2

RADIO DIAGRAMS FOR PREVIOUS YEARS

Speed up and simplify all radio repairs. Service radios faster, better, easier, save money and time, use these **SUPREME Most-Often-Needed** diagram manuals to get ahead. At the low cost (only \$2 for most volumes) you are assured of having for every job needed diagrams and other essential repair data on 4 out of 5 sets you will ever service. Clearly printed circuits, parts lists, alignment data, and helpful service hints are the facts you need. Average volume has 192 pages, large size 8½ x 11 inches. Manual style binding.

- | | | | | |
|--|--|--|--|--|
| <input type="checkbox"/> 1954
Volume 14
\$2.50 | <input type="checkbox"/> 1953
Volume 13
\$2.50 | <input type="checkbox"/> 1952
Volume 12
\$2.50 | <input type="checkbox"/> 1951
Volume 11
\$2.50 | <input type="checkbox"/> 1950
Volume 10
\$2.50 |
| <input type="checkbox"/> 1949
Volume 9
\$2.50 | <input type="checkbox"/> 1948
Volume 8
\$2.00 | <input type="checkbox"/> 1947
Volume 7
\$2.00 | <input type="checkbox"/> 1946
Volume 6
\$2.00 | <input type="checkbox"/> 1942
Volume 5
\$2.00 |
| <input type="checkbox"/> 1941
Volume 4
\$2.00 | <input type="checkbox"/> 1940
Volume 3
\$2.00 | <input type="checkbox"/> 1939
Volume 2
\$2.00 | <input type="checkbox"/> 1926-1938
Volume 1
\$2.50 | |

INDEX for all Radio and TV Manuals 25¢

RADIO MATHEMATICS



Explains arithmetic and simple algebra in connection with units, color code, meter scales, Ohm's law, alternating currents, ohmmeter testing, wattage rating, series and parallel connections, capacity, inductance, mixed circuits, vacuum tubes, curves, the decibel, etc., and has numerous examples. Only **25¢**

How to Modernize Radios



Cash in by improving and modernizing all out of date radio sets and cabinets. Practical job-sheets with schematics and photographs make this work easy. Size 8½ x 11 inches. Your price only **\$1**

POST-WAR RECORD CHANGERS

Service expertly all 1945-1948 record changers. Includes every popular make. Just follow simplified factory instructions to make needed adjustments and repairs. Hundreds of photographs and exploded views. Large size: 8½ x 11 inches. 144 fact-filled pages. Only **\$1.50**

ARVIN DIAGRAM Manual 50¢

RADIO SERVICING COURSE



Here is your practical radio course of 22 easy-to-follow lessons. Review fundamentals, learn new servicing tricks. Just like a \$200.00 correspondence course. Everything in radio servicing. With self-testing questions. New edition. Price only **\$2.50**

SUPREME TELEVISION MANUALS

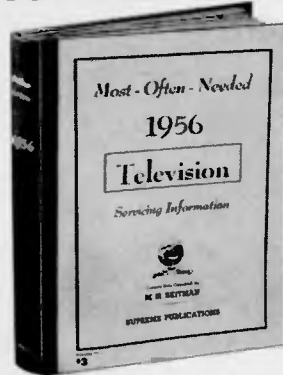

1956 TV Manual, TV-11

This new giant volume of 1956 television factory data will give you everything you need to repair and adjust all present-day TV sets. The **television series** manuals are amazing bargains and defy competition. The 1956 volume contains circuit explanations, 192 pages of alignment facts, test patterns, response curves, waveforms, voltage charts, hints, and dozens of mammoth double-page work-bench diagrams. Large size 8½ x 11 inches. Sturdy covers. Book binding opens flat. Amazing value. Price postpaid, only **\$3**

EARLIER TV MANUALS FOR 1955 TO 1947

Supreme TV manuals cover all needed service material on every popular TV set of every important manufacturer. Here is helpful, practical, factory-prepared data that will really make TV servicing and adjustment easy for you. **Supreme** giant TV manuals have complete circuits, alignment facts, test patterns, response curves, service hints, recommended changes, voltage charts, waveforms, and many double-page diagram blueprints. Here is your TV service material to help you do more expert work quicker: and priced at only \$3 and \$2 per manual covering a full year of material. (See list below.) The new **UHF Converters** manual at only \$1.50 has everything you need on UHF. **Radio** manuals described at left.

- | | | | |
|---|--|---|---|
| <input type="checkbox"/> 1955 TV
Additional, TV-10
\$3.00 | <input type="checkbox"/> 1955 TV
Early, Vol. TV-9
\$3.00 | <input type="checkbox"/> 1954 TV
Volume TV-8
\$3.00 | <input type="checkbox"/> 1953 TV
Volume TV-7
\$3.00 |
| <input type="checkbox"/> 1952 TV
Volume TV-6
\$3.00 | <input type="checkbox"/> 1951 TV
Volume TV 5
\$3.00 | <input type="checkbox"/> 1950 TV
Volume TV-4
\$3.00 | <input type="checkbox"/> 1949 TV
Volume TV-3
\$3.00 |
| <input type="checkbox"/> 1948 TV
Volume TV-2
\$3.00 | <input type="checkbox"/> 1947 TV & FM
Volume TV-1, \$2.00 | <input type="checkbox"/> UHF Converters
Volume UHF-1, \$1.50 | |

TELEVISION SERVICING COURSE

Let this new course teach you TV servicing. Amazing bargain, complete only \$3, full price for all lessons. Giant in size, mammoth in scope, topics just like a \$200.00 correspondence course. Lessons on picture faults, circuits, adjustments, short-cuts, UHF, alignment hints, antenna problems, trouble-shooting, test equipment, picture analysis. Special, only **\$3**

Practical Radio & Electronics Course

Here is your complete home study course of 53 lessons designed to train any beginner to be an expert in radio and electronics. Covers every topic of radio, electronics, with lessons on test equipment, FM, TV, radio, etc. Giant 8½ x 11 inches, 3-in-1 volume, includes all lessons, instructor's notes, test questions. New 1953 edition. Only **\$3.95**

ANSWER BOOK to the above course 25¢

Simplified Radio Servicing by COMPARISON Method



Revolutionary different **COMPARISON** technique permits you to do expert work on all radio sets. Most repairs can be made without test equipment or with only a volt-ohmmeter. Many simple, point-to-point, cross-reference, circuit suggestions locate the faults instantly. Plan copyrighted. Covers every radio set — new and old models. This new servicing technique presented in handy manual form, size 8½ x 11 inches, 92 pages. Over 1,000 practical service hints. 26 large, trouble-shooting blueprints. Charts for circuit analysis. 114 tests using a 5c resistor. Developed by M. N. Beitman. New edition. Price only **\$1.50**

Admiral

CHASSIS 4G2, 4G2A
 MODELS 4G22D (TABLE TOP)
 4D18D, 4D28D

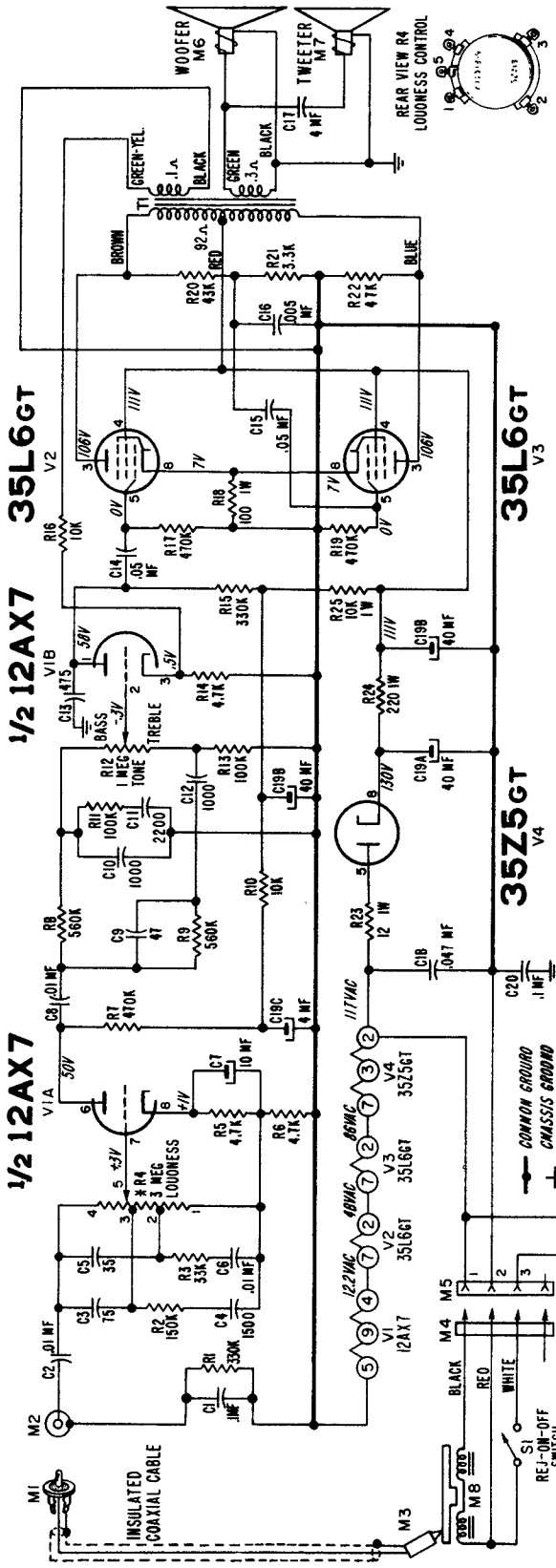

VOLTAGE DATA

- Voltages shown on schematic diagram
- All readings made between tube socket terminals and common ground.
 - Loudness control set at minimum.
 - Measured on 117 Volts AC, 60 cycle line.
 - All voltages measured with vacuum-tube voltmeter.
 - Tone control set at mid-rotation.

Service Note: The "REJ-ON-OFF" pointer (S1) on the record changer is used to turn both amplifier and record changer motor on and off. To turn the amplifier on and measure voltages with the record changer disconnected, a short, temporary jumper wire must be connected from common ground (2) to the single lead from the AC line cord (3) on "M5". See schematic.

CHASSIS 4G2, 4G2A
 MODELS 4G22D (TABLE TOP)
 4D18D, 4D28D

Model 4G22D:
 Tie the **Tone Arm** to the tone arm rest or to the centerpost. Turn the set upside-down on a padded surface and remove the screws which mount the cabinet bottom.

To Remove the Chassis From the Cabinet: Follow the procedure outlined for "Replacing Tubes" then proceed as follows:

For Models 4D18D and 4D28D the chassis may be removed while the record changer is out of the cabinet by removing the nuts that mount the chassis to the cabinet and the nuts mounting the speaker to the cabinet. The output transformer leads are soldered to the speakers; speakers and chassis should be removed as a unit.

For Model 4G22D the screws mounting the baffle board assembly to the cabinet must be removed. The entire assembly including speakers, amplifier and baffle board will then come out of the cabinet. Remove the speakers and amplifier by removing the nuts which fasten them to the baffle board.

TUBE AND COMPONENT REPLACEMENT
To Replace Tubes: In Models 4D18D and 4D28D Portable Phonograph, the speaker compartment cover and the record changer and mounting board must be removed to make the tubes accessible. In Model 4G22D Table Phonograph the bottom cover must be removed to service tubes.

To service tubes in either of the models, remove the line cord plug from the wall outlet; then follow specific instructions as follows:

Models 4D18D—4D28D:
 Remove the mounting screws from the speaker compartment cover and lift the cover from cabinet. The record changer and its mounting board come out as a unit. Fasten the **Tone Arm** to the tone arm rest. Remove the mounting board screws. Tilt the right edge of the mounting board until the record changer and mounting board clear the cabinet lid stay-arm mounting bracket. It should not be necessary to remove this bracket. If, however, it is ever necessary to remove this bracket, care must be taken to avoid damaging the cabinet lid hinges. Carefully lift the record changer and mounting board from the cabinet.

Admiral

CHASSIS 5A4
 MODEL 5A42 • 5A43
 5A44 • 5A48

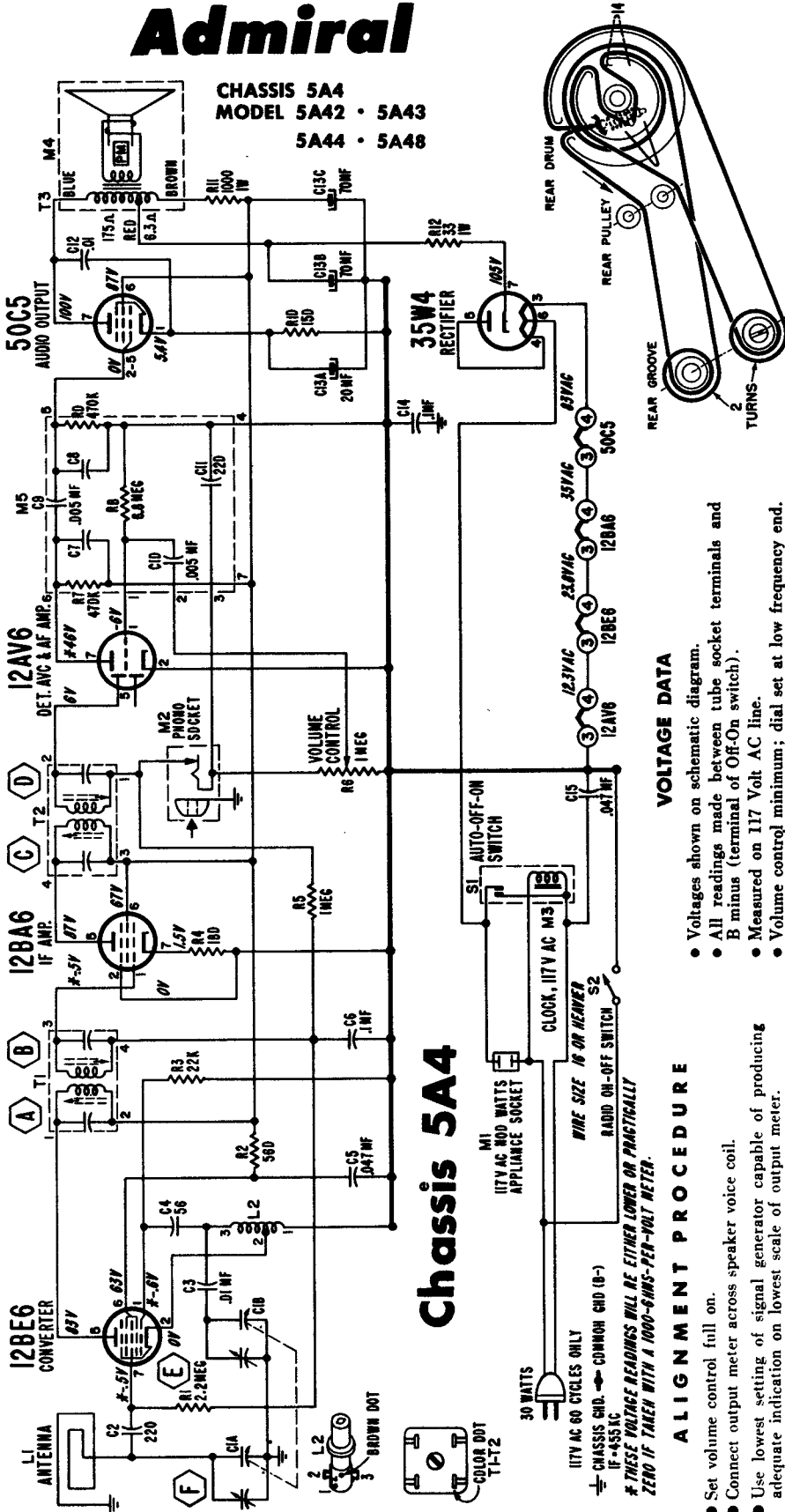

Chassis 5A4

VOLTAGE DATA

- Voltages shown on schematic diagram.
- All readings made between tube socket terminals and B minus (terminal of Off-On switch).
- Measured on 117 Volt AC line.
- Volume control minimum; dial set at low frequency end.
- Voltages measured with vacuum-tube voltmeter.

ALIGNMENT PROCEDURE

- Set volume control full on.
- Connect output meter across speaker voice coil.
- Use lowest setting of signal generator capable of producing adequate indication on lowest scale of output meter.
- Use a non-metallic alignment tool with a blade 3/32" wide for aligning IF transformers.

STEP	CONNECTION OF SIGNAL GENERATOR	SIGNAL GENERATOR FREQUENCY	RECEIVER GANG SETTING	ADJUSTMENT
1	Through a .1 mf capacitor to pin 7 of the 12BE6 (Converter) tube	455 KC	Gang fully open	"A", "B", "C" and "D" for maximum output
2	Same as "STEP 1"	1620 KC	Gang fully open	"E" for maximum output
3	Radiated Signal. Loop of several turns of wire, or place generator lead close to receiver loop for adequate signal pickup.	1400 KC	Tune in generator signal	"F" for maximum output

*Adjustments "C" and "A" made from underside of chassis.

Admiral

CHASSIS 5N3
MODEL 5M36D • 5M37D • 5M56D • 5M57D

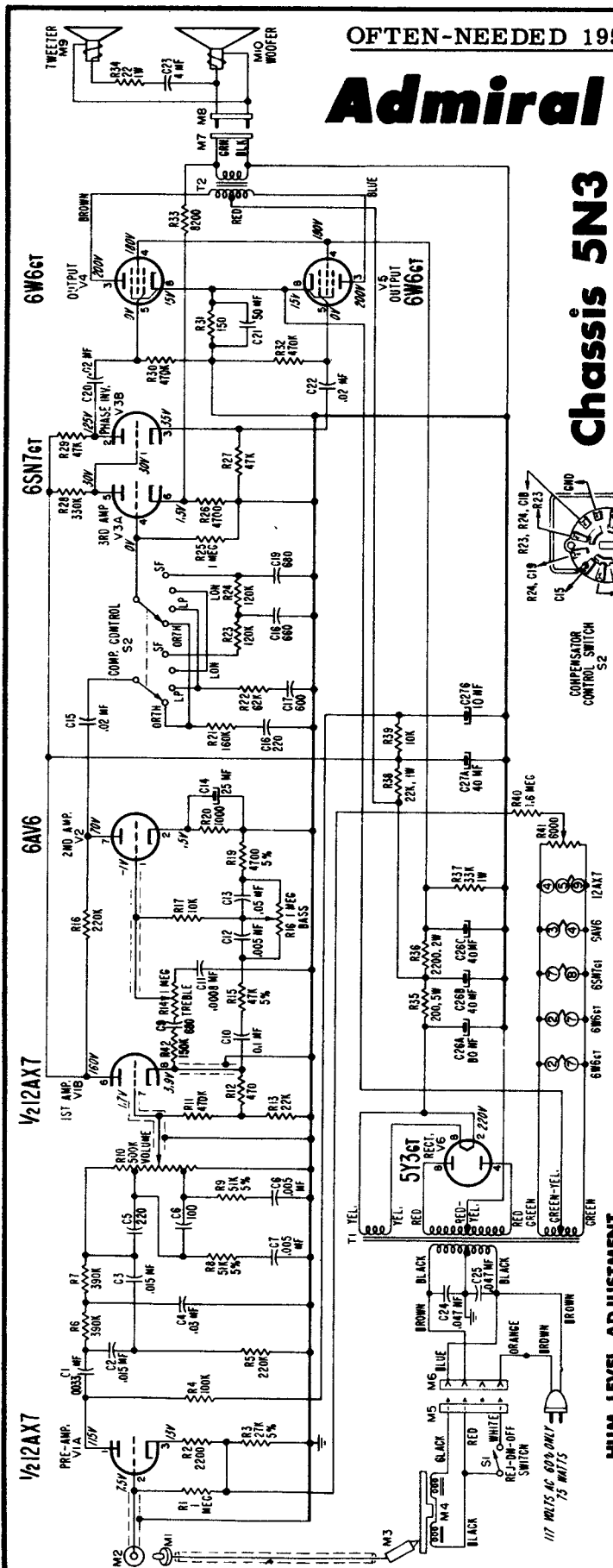

Chassis 5N3

TUBE LOCATIONS

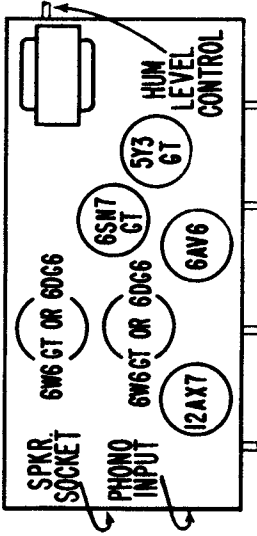

- Voltages shown on schematic diagram.
- All readings made between tube socket terminals and chassis ground.
- Volume control set at minimum.
- Measured on 117 Volts AC, 60 cycle line.
- All voltages measured with vacuum tube voltmeter.

LOCATIONS illustration. On console models, this control is accessible through a hole in the back of the cabinet.

TUBE AND COMPONENT REPLACEMENT

To Replace Tubes: All tubes are readily accessible through the ventilation opening in the bottom of the cabinet on models 5M36D and 5M37D. To reach inaccessible components on these models, it is suggested that the cabinet bottom be removed. Proceed as follows:

Remove the line cord plug from the wall outlet. Clamp the **Tone Arm** to the tone arm rest. Carefully turn the phonograph upside down on a soft-padded surface. Remove the cabinet bottom mounting screws and lift the cabinet bottom and legs off the cabinet. Chassis is now readily accessible.

On console models 5M56D and 5M57D, the cabinet back must be removed to make the tubes accessible. Remove the line cord from the wall outlet. Remove the cabinet back mounting screws and cabinet back. Tubes are now readily accessible.

HUM LEVEL ADJUSTMENT

Turn the set on by sliding the **Rej-On-Off** switch on the record changer to the "On" position. Set the **Comp** control to the "Lon" position. Set **Bass** and **Treble** controls to their "Max" (fully clockwise) position. Set **Volume** control to a position where hum is noticeable.

Line cord polarity is very important for correct amplifier operation. If touching the centerpost on the record changer increases the hum level, reverse the line cord in the wall outlet. Touch the centerpost again. Leave the line cord plug in the position that gives the least amount of hum when the centerpost is touched.

The adjustment of the hum bucking potentiometer (see schematic, R41) determines the magnitude of 60 cycle out-of-phase voltage fed to stage V1A. The potentiometer can be adjusted to minimize hum as follows:

Turn the **Volume** control fully clockwise. On chairside models, reach through the ventilation opening in the bottom of the cabinet and adjust the **Hum Level Control (R41)** for minimum 60 cycle hum level. Location of control is shown on "TUBE

Admiral

CHASSIS 5W3
 MODELS 5W32 • 5W33 • 5W34 • 5W38
 5W39 • 5B42 • 5B43 • 5B48

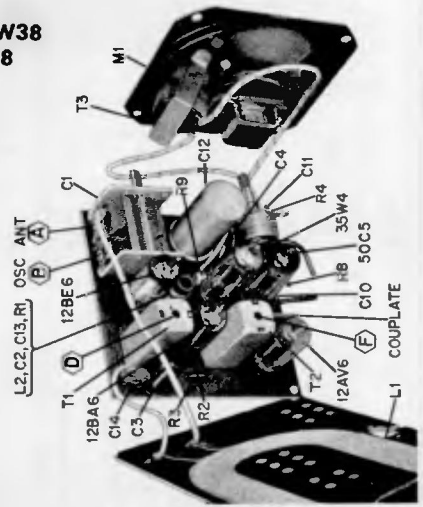
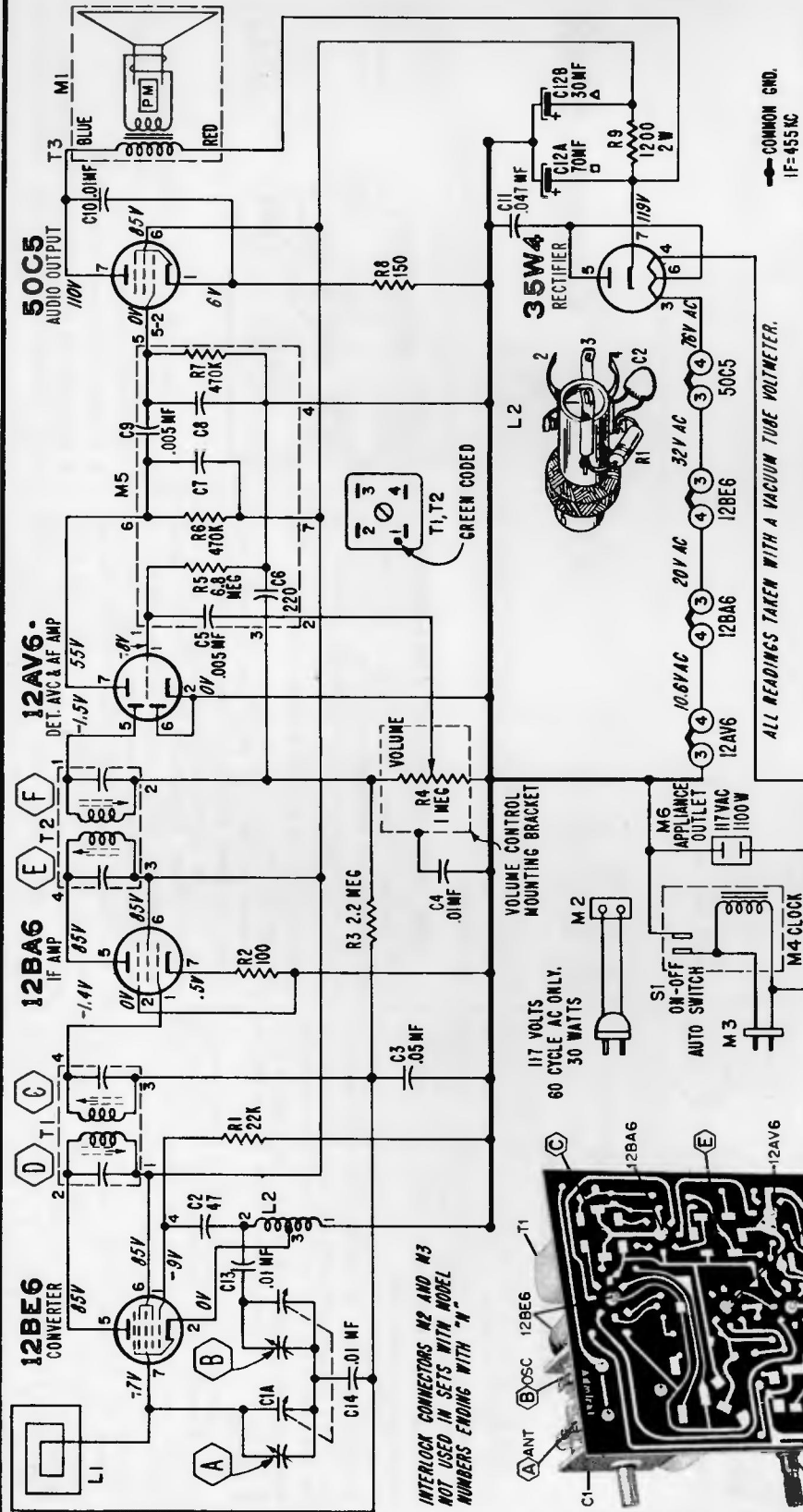

STEP	CONNECTION OF SIGNAL GENERATOR	SIGNAL GENERATOR FREQUENCY	RECEIVER GANG SETTING	ADJUSTMENT
1	Through a .1 mf capacitor to stator, Antenna section of gang tuning capacitor	455 KC	Gang fully open	"E", "F", "C" and "D" for maximum output
2	Same as "STEP 1"	1620 KC	Gang fully open	"B" for maximum output
3	Radiated Signal. Loop of several turns of wire, or place generator lead close to receiver loop for adequate signal pickup.	1400 KC	Tune in generator signal	"A" for maximum output

*Adjustments "C" and "E" made from underside of chassis.

Admiral

CHASSIS 6R2
MODEL 5M66D • 5M67D

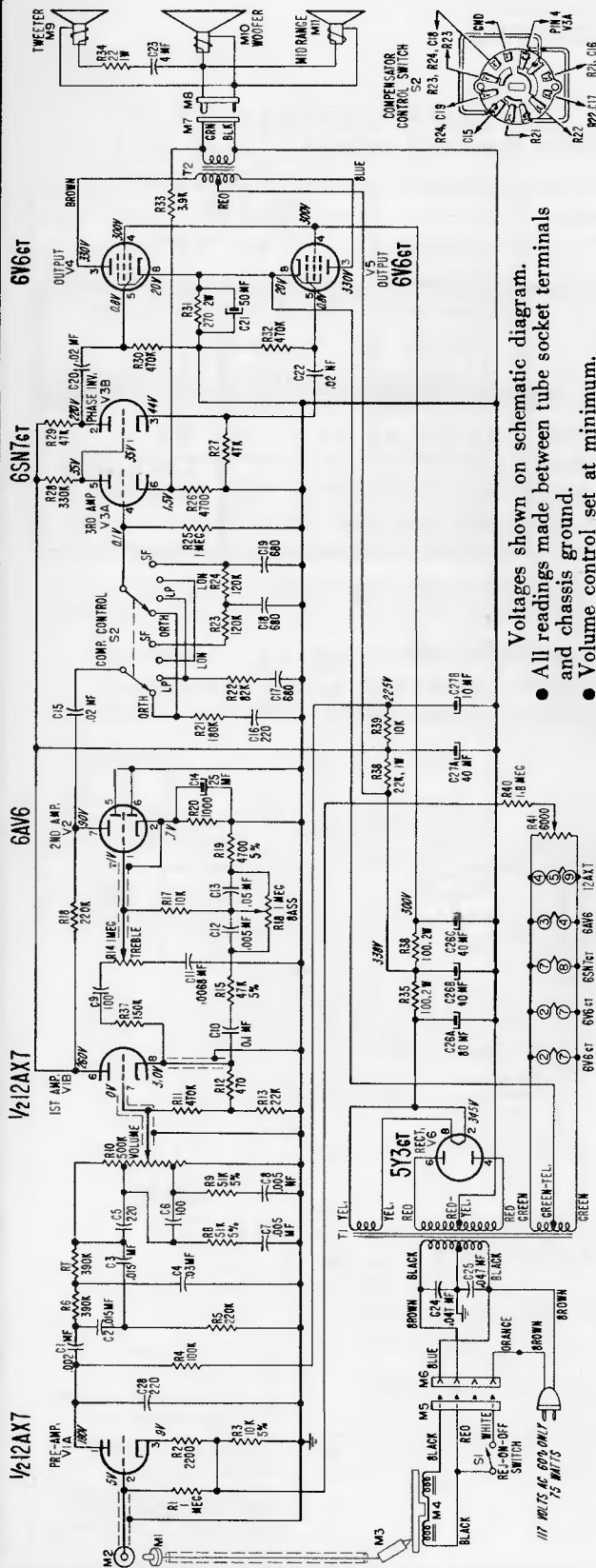

Voltages shown on schematic diagram.
 ● All readings made between tube socket terminals and chassis ground.
 ● Volume control set at minimum.

lead to R1 on (M2), audio input socket on chassis. Allow several minutes for oscillator and amplifier to warm up. Set **Comp** control to the "Lon" position. Set the tone controls to their "0" position.

Adjust audio oscillator output to .2 volt at 1,000 cycles, measured with the vacuum tube voltmeter from socket (M2) to chassis ground. (This voltage calibration must be made every time a response check at a new frequency setting is to be made.) Measure output across voice coil leads from output transformer with speakers connected or with proper (3.2 ohm) load.

NEEDLE REPLACEMENT

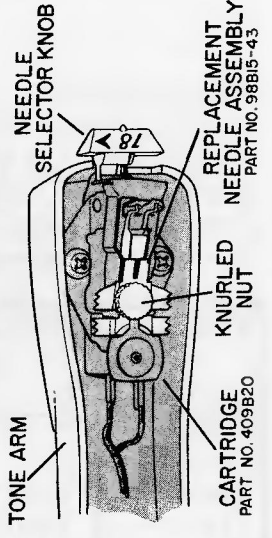

TROUBLE SHOOTING HINTS

If the phonograph sounds weak or distorted, examine the needles for wear. A worn needle may cause excessive needle scratch and a harshness of treble tones. Test the tubes and, if possible, the cartridge by substitution. Check voltage at tube pins.

Amplification and Response Check: The amplifier may be checked for gain and frequency response by using the tests outlined below.

Test Equipment Specifications:

Audio Oscillator, preferably with flat output from 30 cycles to 30 kilocycles.

Vacuum Tube Voltmeter, preferably with decibel scale. Procedure: Connect record changer motor plug and speaker plug to their sockets on chassis. Disconnect audio input plug from socket on chassis. Unclamp **Tone Arm** from tone arm rest and move **Rej-On-Off** switch to "ON" position. (If record changer goes into change cycle and shuts off, move the switch to the "On" position again.)

Connect audio oscillator ground lead to the amplifier chassis. Connect audio oscillator signal

HUM LEVEL ADJUSTMENT

Turn the set on by sliding the **Rej-On-Off** switch on the record changer to the "Lon" position. Set the **COMP** control to the "Lon" position. Set **Bass** and **Treble** controls to their "Max" (fully clockwise) position. Set **Volume** control to a position where hum is noticeable.

Line cord polarity is very important for correct amplifier operation. If touching the centerpost on the record changer increases the hum level, reverse the line cord in the wall outlet. Touch the centerpost again. Leave the line cord plug in the position that gives the least amount of hum when the centerpost is touched.

The adjustment of the hum bucking potentiometer (see schematic, R41) determines the magnitude of 60 cycle out-of-phase voltage fed to stage V1A. The potentiometer can be adjusted to minimize hum as follows:

Turn the **Volume** control fully clockwise. Adjust the **Hum Level** control (R41) for minimum 60 cycle hum level. Location of control is shown on "Tube Locations" illustration. A hole is provided in the cabinet back to make this adjustment accessible.

Arvin INDUSTRIES, INC.

Models 950T, 951T

Chassis RE-391

ALIGNMENT PROCEDURE

PRELIMINARY:

- Output meter connection Across speaker voice coil
- Output meter reading to indicate 500 milliwatts (standard output) . . . 1.26 volts
- Connection of generator ground lead Floating ground
- Generator modulation 30% 400 cycles
- Position of volume control Fully clockwise

Position of Variable	Frequency of Generator	Dummy Antenna	Generator Output Connection	Trimmers Adjusted in Order Shown for Maximum Output	Function of Trimmer
Open	455	.05 μ f	Pin 7 12BE6	A1, A2, A3, A4	I. F.
Open	1650		* Test Loop	A5	Oscillator
1400	1400		* Test Loop	A6	Antenna
600	600		* Test Loop	Check Point	

* Standard Hazeltine Test Loop Model 1150 or 3 turns of wire about 6" in diameter placed about one foot from the set loop.

The alignment procedure should be repeated in the original order for greatest accuracy. Always keep the output from the signal generator at its lowest possible value to make the AVC action of the receiver ineffective.

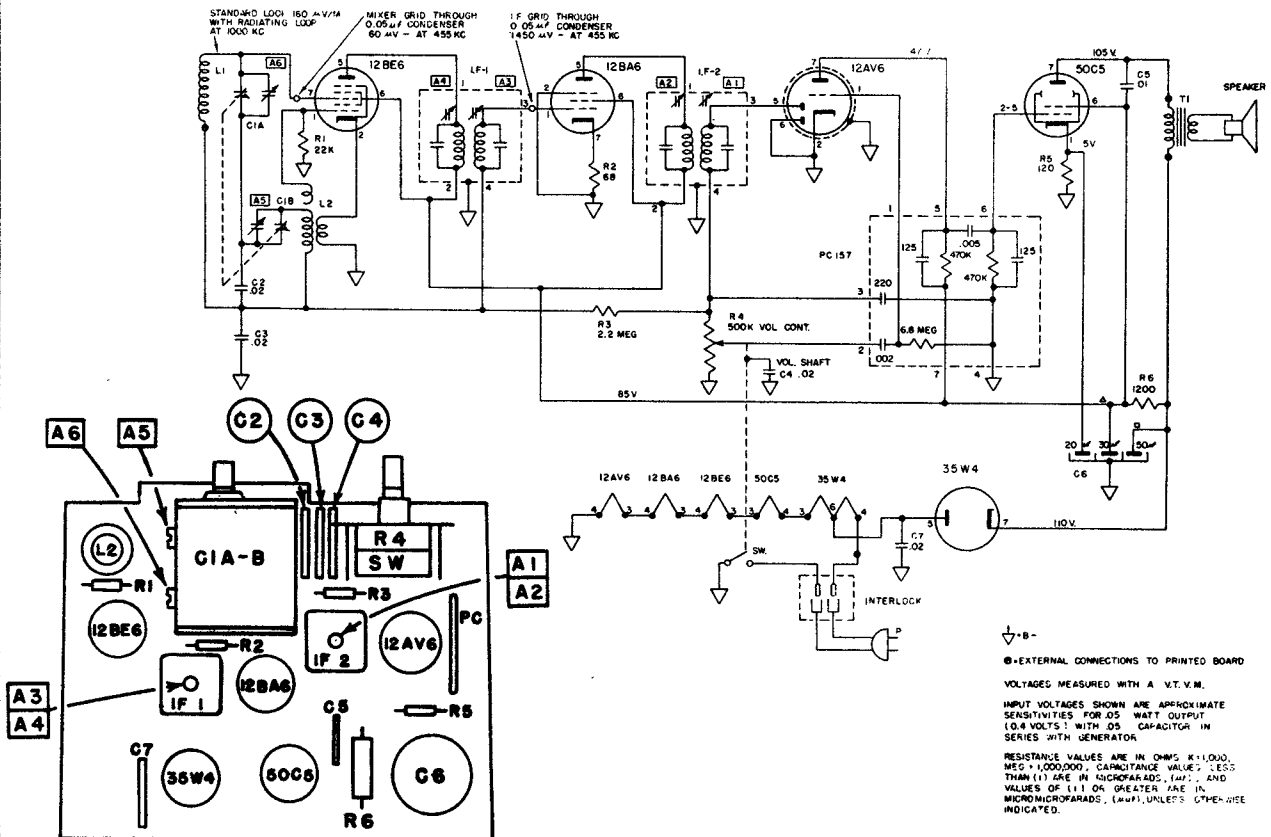

ARVIN INDUSTRIES

Model 956T

Chassis RE-392

ALIGNMENT PROCEDURE

PRELIMINARY:

Output meter connection.....Across speaker voice coil
 Connection of generator ground lead Floating ground
 Position of Volume Control Fully clockwise

Position of Variable	Frequency of Generator	Dummy Antenna	Generator Output Connection	Trimmers Adjusted in Order Shown for Maximum Output	Functions of Trimmer
Open	455	.05 μ f	Pin 7 12BE6	A1, A2, A3, A4	I. F.
Open	1650		* Test Loop	A5	Oscillator
1400	1400		* Test Loop	A6	Antenna
600	600		* Test Loop	Check Point	

* Standard Hazeltine Test Loop Model 1150 or 3 turns of wire about 6" in diameter placed about one foot from the set loop.
 The alignment procedure should be repeated in the original order for greatest accuracy. Always keep the output from the signal generator at its lowest possible value to make the AVC action of the receiver ineffective.

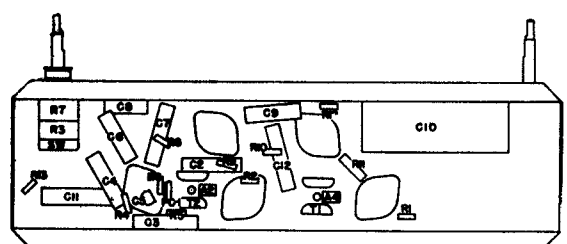
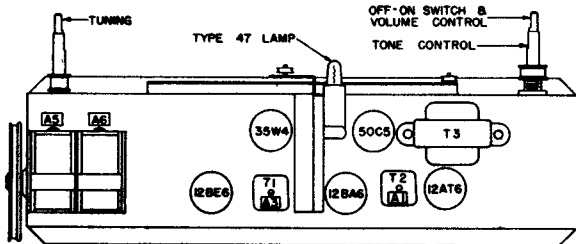

APPROXIMATE INPUT FOR 500 MILLIWATTS OUTPUT 112.6 VOLTS ACROSS VOICE COIL) 30% MODULATION AT 400 C.P.S.
 GENERATOR THROUGH STANDARD LOOP 500 μ W / M AT 1000 KC
 GENERATOR THROUGH .05 μ f CONNECTED TO GRID 150 μ V AT 455 KC
 GENERATOR THROUGH .05 μ f CONNECTED TO GRID 5000 μ V AT 455 KC

LOCATION OF PARTS UNDER CHASSIS

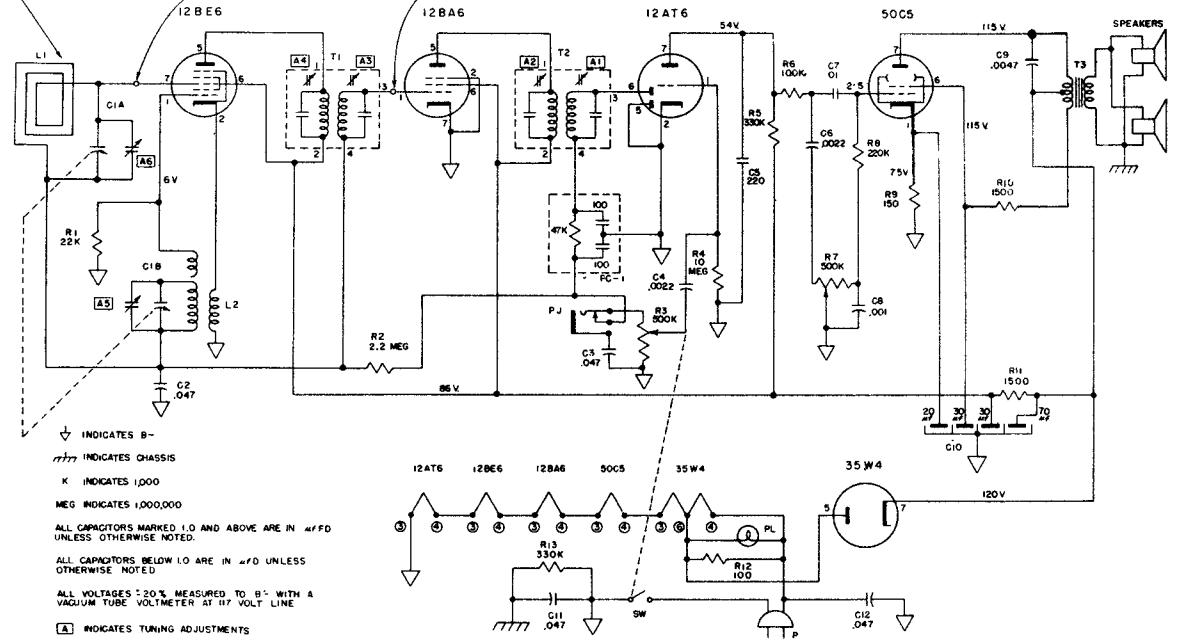

↓ INDICATES B-
 --- INDICATES CHASSIS
 K INDICATES 1,000
 MEG INDICATES 1,000,000
 ALL CAPACITORS MARKED 1.0 AND ABOVE ARE IN μ F UNLESS OTHERWISE NOTED.
 ALL CAPACITORS BELOW 1.0 ARE IN μ D UNLESS OTHERWISE NOTED.
 ALL VOLTAGES : 20% MEASURED TO B- WITH A VACUUM TUBE VOLTMETER AT 117 VOLT LINE
 [A] INDICATES TUNING ADJUSTMENTS

VOLUME R-16, MOST-OFTEN-NEEDED 1956 RADIO SERVICING INFORMATION

ARVIN INDUSTRIES

Model 957T

Chassis RE-393

ALIGNMENT PROCEDURE

PRELIMINARY:

- Output meter connection Across speaker voice coil
- Output meter reading to indicate 500 milliwatts (standard output) . . . 1.26 volts
- Connection of generator ground lead Floating ground
- Generator modulation 30% 400 cycles
- Position of Volume Control Fully clockwise

Position of Variable	Frequency of Generator	Dummy Antenna	Generator Output Connection	Trimmers Adjusted in Order Shown for Maximum Output	Function of Trimmer
Open	455 Kc	.05 μ fd	Pin 7 12BE6	A1, A2, A3, A4	I. F. Oscillator Antenna
Open	1650 Kc		* Test Loop	A5	
1400	1400 Kc		* Test Loop	A6	
1000	1000 Kc		* Test Loop	Fan C1A Plates	
600	600 Kc		* Test Loop	Fan C1A Plates	

* Standard Hazeltine Test Loop Model 1150 or 3 turns of wire about 6" in diameter placed about one foot from the set loop.
The alignment procedure should be repeated in the original order for greatest accuracy.

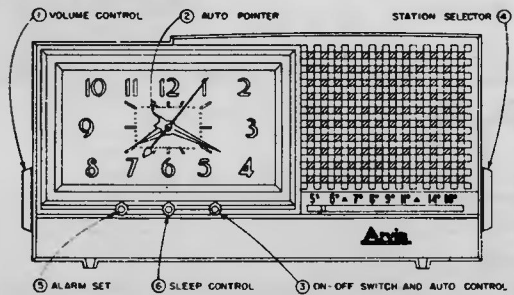
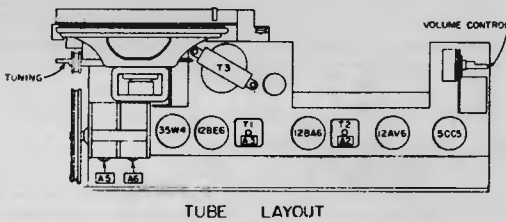

APPROXIMATE INPUT FOR 500 MILLIWATTS OUTPUT (1.26 VOLTS ACROSS VOICE COIL) 30% MODULATION AT 400 C.P.S.

GENERATOR THROUGH STANDARD LOOP 100 UV / 76 AT 1000 KC
GENERATOR THROUGH OS CONNECTED TO GRID 150 UV AT 455 KC
GENERATOR THROUGH OS CONNECTED TO GRID 400 UV AT 455 KC

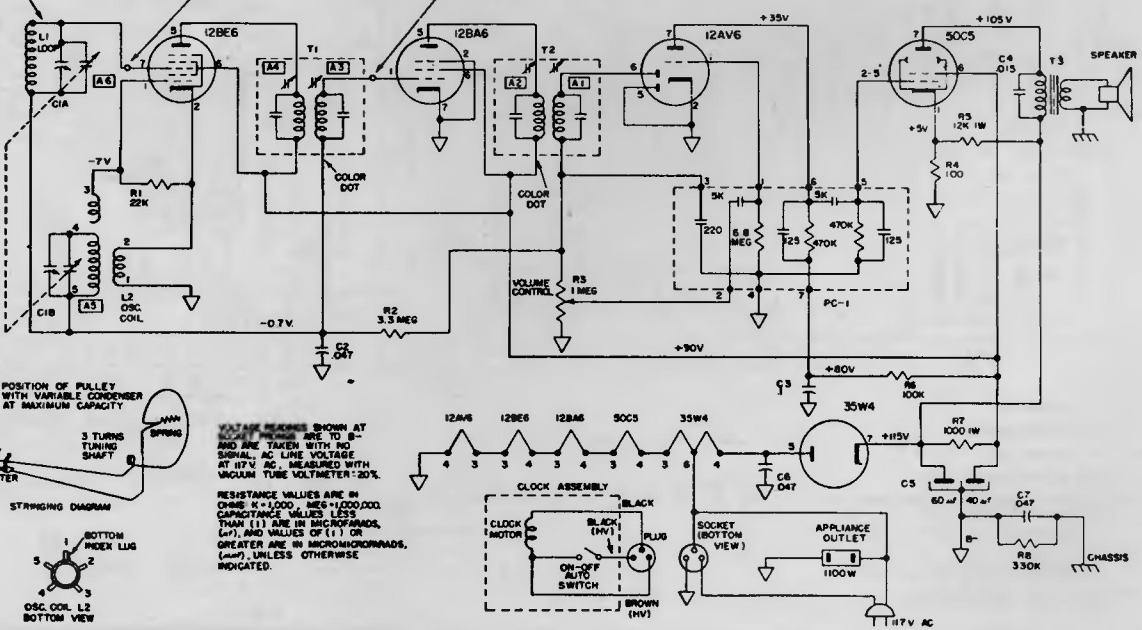

ARVIN INDUSTRIES

Model 958T

Chassis RE-397

ALIGNMENT PROCEDURE

PRELIMINARY:

Output meter connection Across speaker voice coil
 Output meter reading to indicate 500 milliwatts (standard output) . . . 1.26 volts
 Connection of generator ground lead Floating ground
 Generator modulation 30% 400 cycles
 Position of Volume Control Fully clockwise

Position of Variable	Frequency of Generator	Dummy Antenna	Generator Output Connection	Trimmers Adjusted in Order Shown for Maximum Output	Function of Trimmer
Open	455 Kc	.05 μ fd	Pin 7 12BE6	A1, A2, A3, A4	I. F. Oscillator Antenna
Open	1650 Kc		* Test Loop	A5	
1400	1400 Kc		* Test Loop	A6	
1000	1000 Kc		* Test Loop	Fan C1A Plates	
600	600 Kc		* Test Loop	Fan C1A Plates	

* Standard Hazeltine Test Loop Model 1150 or 3 turns of wire about 6" in diameter placed about one foot from the set loop.
 The alignment procedure should be repeated in the original order for greatest accuracy.

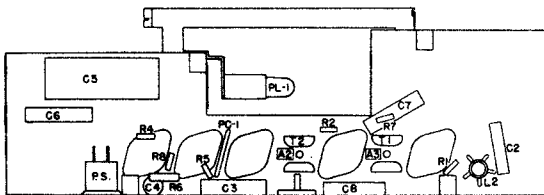

LOCATION OF PARTS UNDER CHASSIS

APPROXIMATE INPUT FOR 500 MILLIWATTS OUTPUT (1.26 VOLTS ACROSS VOICE COIL) 30% MODULATION @ 400 C.P.S.

GENERATOR THROUGH STANDARD LOOP 500 μ V/M AT 1000 KC. GENERATOR THROUGH .05 μ F CONNECTED TO GRID. 150 μ V AT 455 KC. GENERATOR THROUGH .05 μ F CONNECTED TO GRID. 5000 μ V AT 455 KC.

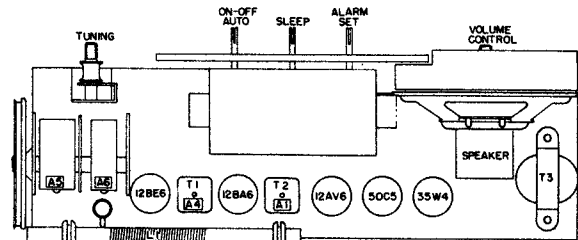

TUBE LAYOUT

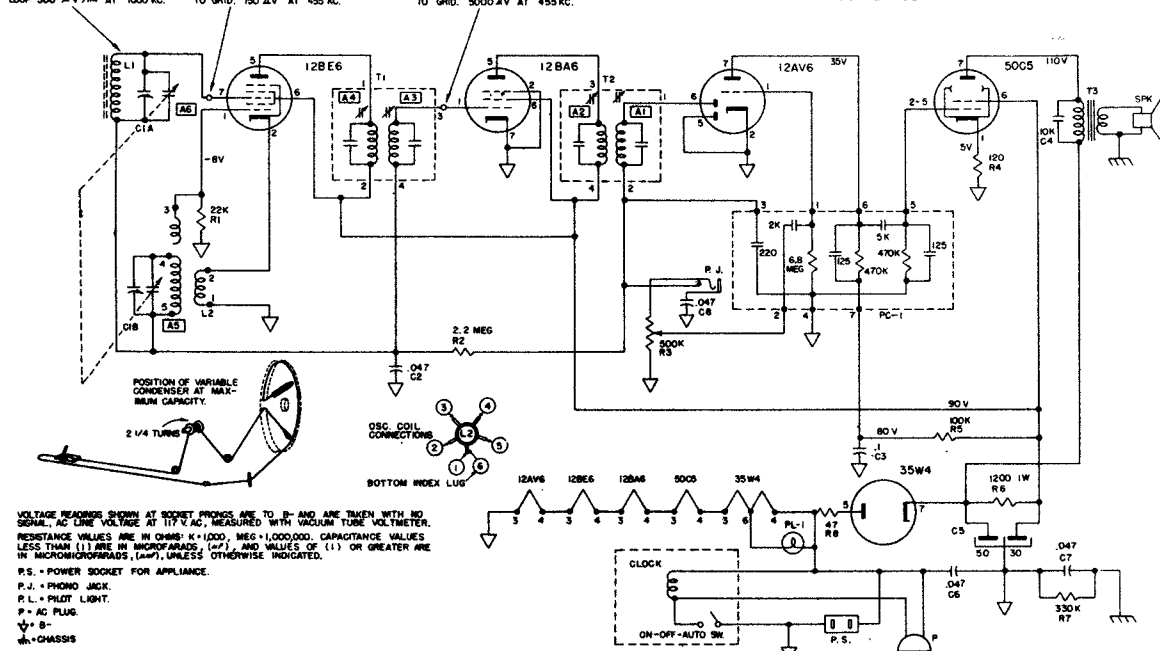

VOLTAGE READINGS SHOWN AT SOCKET PRONGS ARE TO B- AND ARE TAKEN WITH NO SIGNAL, AC LINE VOLTAGE AT 117 V. AC, MEASURED WITH VACUUM TUBE VOLTMETER. RESISTANCE VALUES ARE IN OHMS; K=1,000; MEG=1,000,000. CAPACITANCE VALUES LESS THAN (1) ARE IN MICROFARADS, (μ F), AND VALUES OF (1) OR GREATER ARE IN MICROMICROFARADS, (μ M), UNLESS OTHERWISE INDICATED.
 P.S. - POWER SOCKET FOR APPLIANCE.
 P.J. - PHONO JACK.
 P.L. - PILOT LIGHT.
 P - AC PLUG.
 B- - CHASSIS

CAPEHART-FARNSWORTH COMPANY

Capehart

MODEL
2C56

CHASSIS
CR202

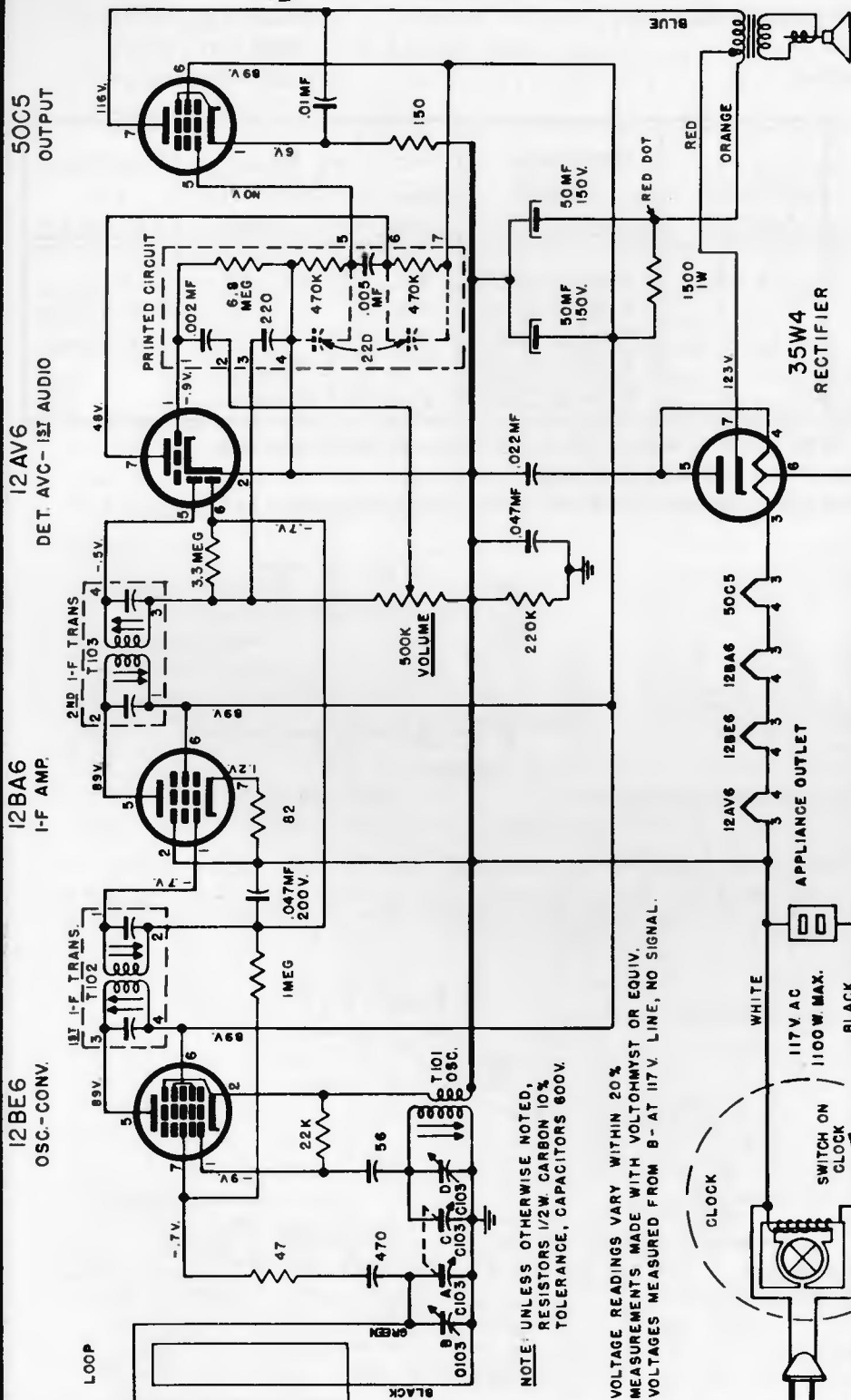

Step	Set RF Generator At	Set Condenser Gang At	Adjust	To Obtain
1	455KC	Fully Open. Disable Osc. Section of Tuning Gang	IF Slugs T103 T102	Max. Output
2	1620KC	1620KC	Osc. Trimmer C103D	Same
3	1500	1500	Ant. Trimmer C103D	Same
4	537KC	537KC	*T101 Osc. Slug	Same

ALIGNMENT INSTRUCTIONS

See that dial pointer coincides with calibration marks at extremes of dial scale.
Connect output meter across the speaker voice coil.
Make a loop of the R-F Generator leads (connect the leads together through a .01mfd capacitor) and loosely couple to the Loop Antenna.
* Adjust as Tuning Gang is Rocked

NOTE: UNLESS OTHERWISE NOTED, RESISTORS 1/2W. CARBON 10% TOLERANCE, CAPACITORS 500V.
VOLTAGE READINGS VARY WITHIN 20% MEASUREMENTS MADE WITH VOLTOMYST OR EQUIV. VOLTAGES MEASURED FROM B- AT 117V LINE, NO SIGNAL.

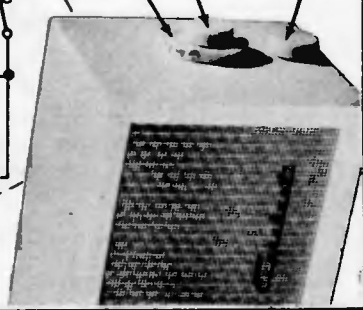

CAPEHART-FARNSWORTH COMPANY

Capehart

Model
2P56

Chassis
CR-218

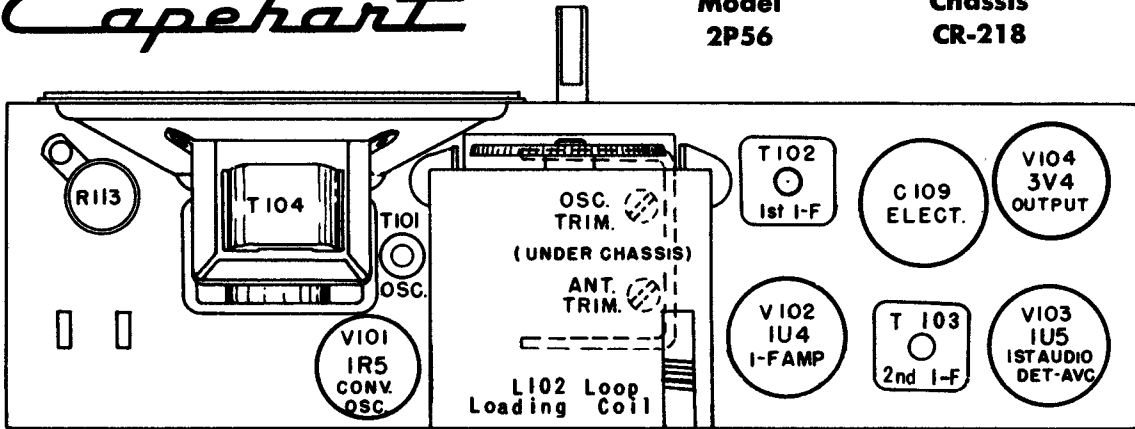

ALIGNMENT INSTRUCTIONS

EQUIPMENT REQUIRED:

1. Calibrated R. F. Signal Generator (455KC to 1620KC)
2. Low Range Output Meter.

ALIGNMENT

Turn set on and adjust for maximum volume. Connect output meter across Speaker Voice Coil.

Step No.	Set R. F. Gen. at	Connect R. F. Generator to	Set Gang to	Adjust	To Obtain
1	455KC (400 cy. mod.)	Pin 6 V102 thru .1mfd cap. Ground Lead to B-	Fully Closed	T103 I. F. Transformer (Top & Bottom)	Maximum
2	455KC (400 cy. mod.)	Pin 6 V101 thru .1mfd cap. Ground Lead to B-	Fully Closed	T102 I. F. Transformer (Top & Bottom)	Maximum
3	540KC (400 cy. mod.)	Pin 6 V101 thru .1mfd cap. Ground Lead to B-	Fully Closed	T101 Oscillator Slug	Maximum
4	1620KC (400 kc mod.)	Pin 6 V101 thru .1mfd cap. Ground Lead to B-	Fully Open	C101D Oscillator Trimmer	Maximum
5	1500KC (400 cy. mod.)	Form a Loop and closely couple to Ant.	1500KC	C101B Antenna Trimmer	Maximum

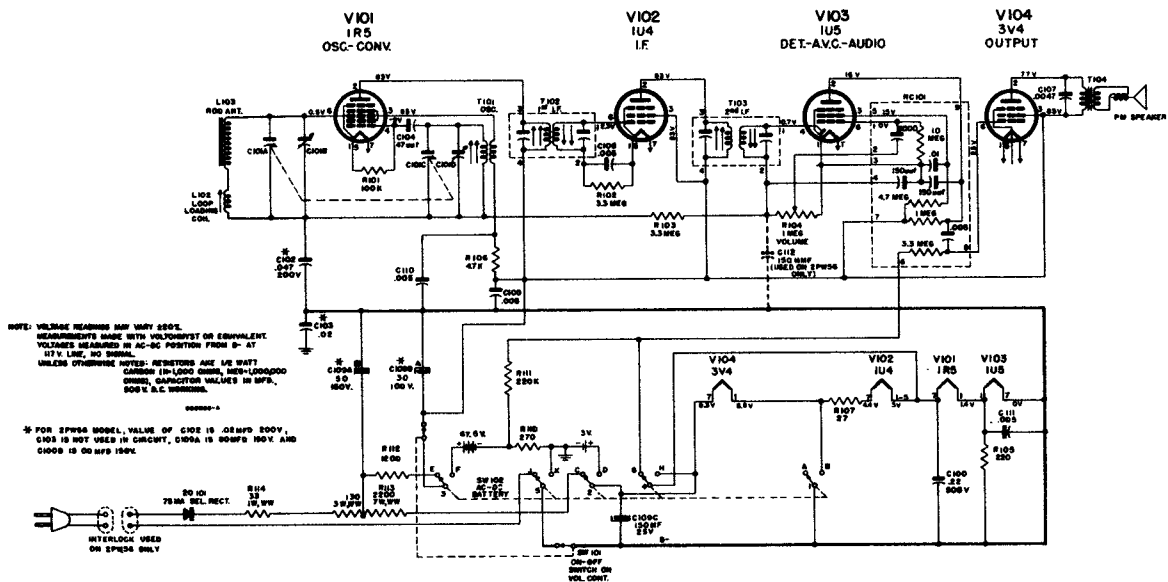

CAPEHART - FARNSWORTH

MODEL
75C56

CHASSIS
CR-242

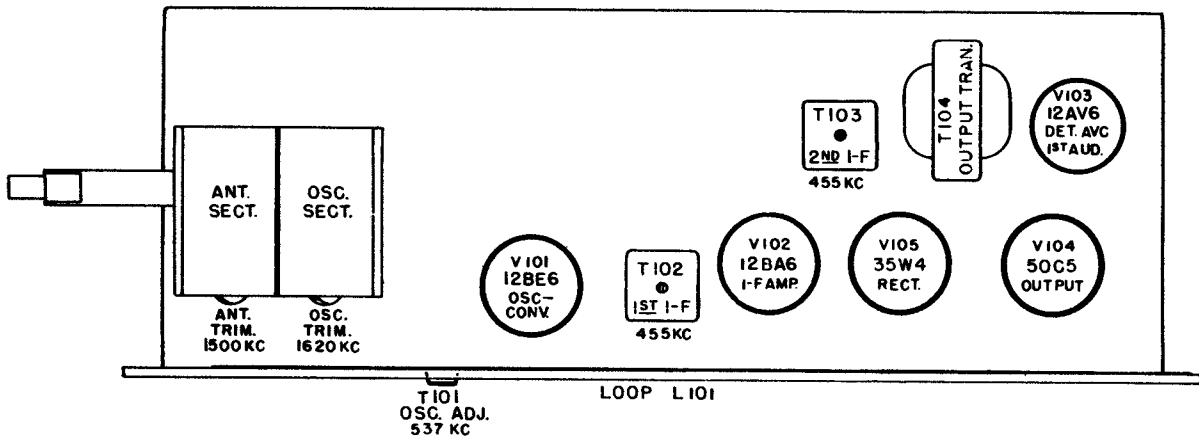

ALIGNMENT

Connect output meter across the speaker voice coil.

Make a loop of the RF Generator leads (connect the leads together through a .01 mfd capacitor) and loosely couple to the Loop Antenna.

STEP	SET RF GENERATOR AT	SET CONDENSER GANG AT	ADJUST	TO OBTAIN
1	455KC	Fully Open at some quiet point	IF Slugs T103 T102	Maximum Output
2	1620KC	1620KC	Osc. Trimmer C103D	Same
3	1500	1500	Ant. Trimmer C103B	Same
4	537KC	537KC	T101 Osc. Slug	Same

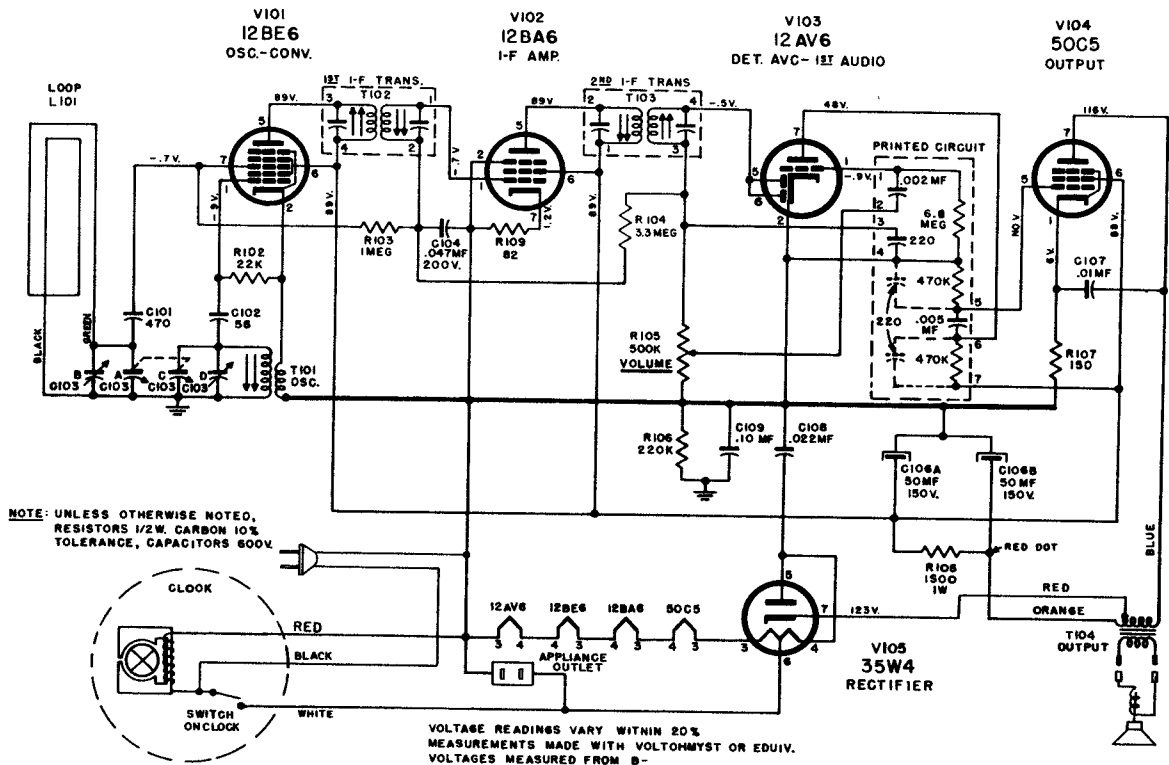

Capehart

Chassis
CA-239

Models
46TP56M
46TP56B

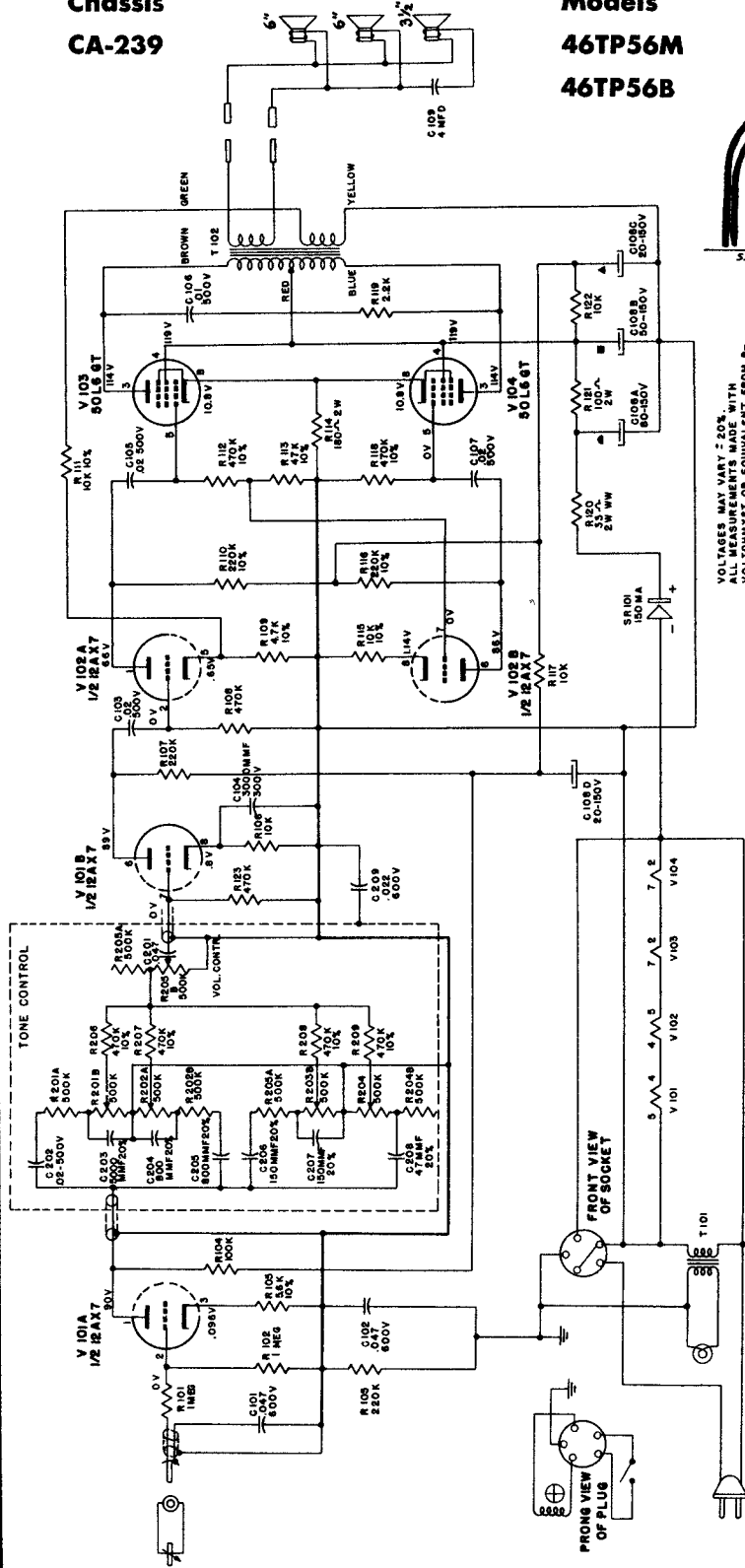

VOLTAGES MAY VARY ± 20%
ALL MEASUREMENTS MADE WITH
VOLTMETER OR EQUIVALENT FROM B-
UNLESS OTHERWISE NOTED:
RESISTORS IN OHMS, KILOHMS,
PAPER CAPACITORS 200 V.

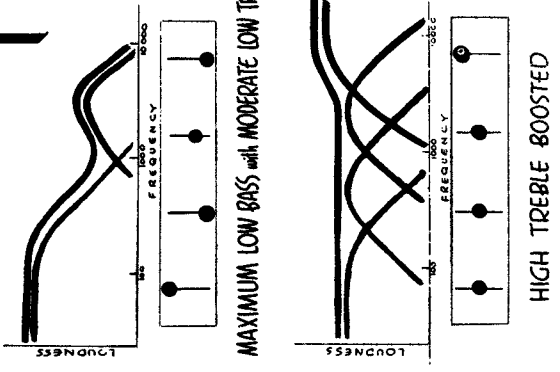

CHASSIS LAYOUT

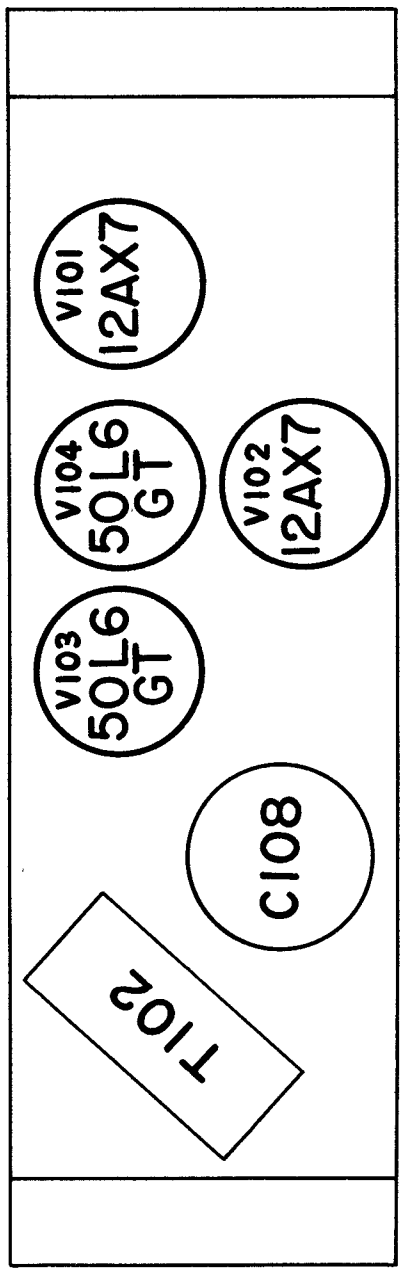

CAPEHART-FARNSWORTH COMPANY

Capehart

**HIGH FIDELITY
PHONOGRAPH**

Instrument Model

52PH56M

53PH56M

52PH56B

53PH56B

53PH56F

Amplifier Chassis

CA-241

CA-251

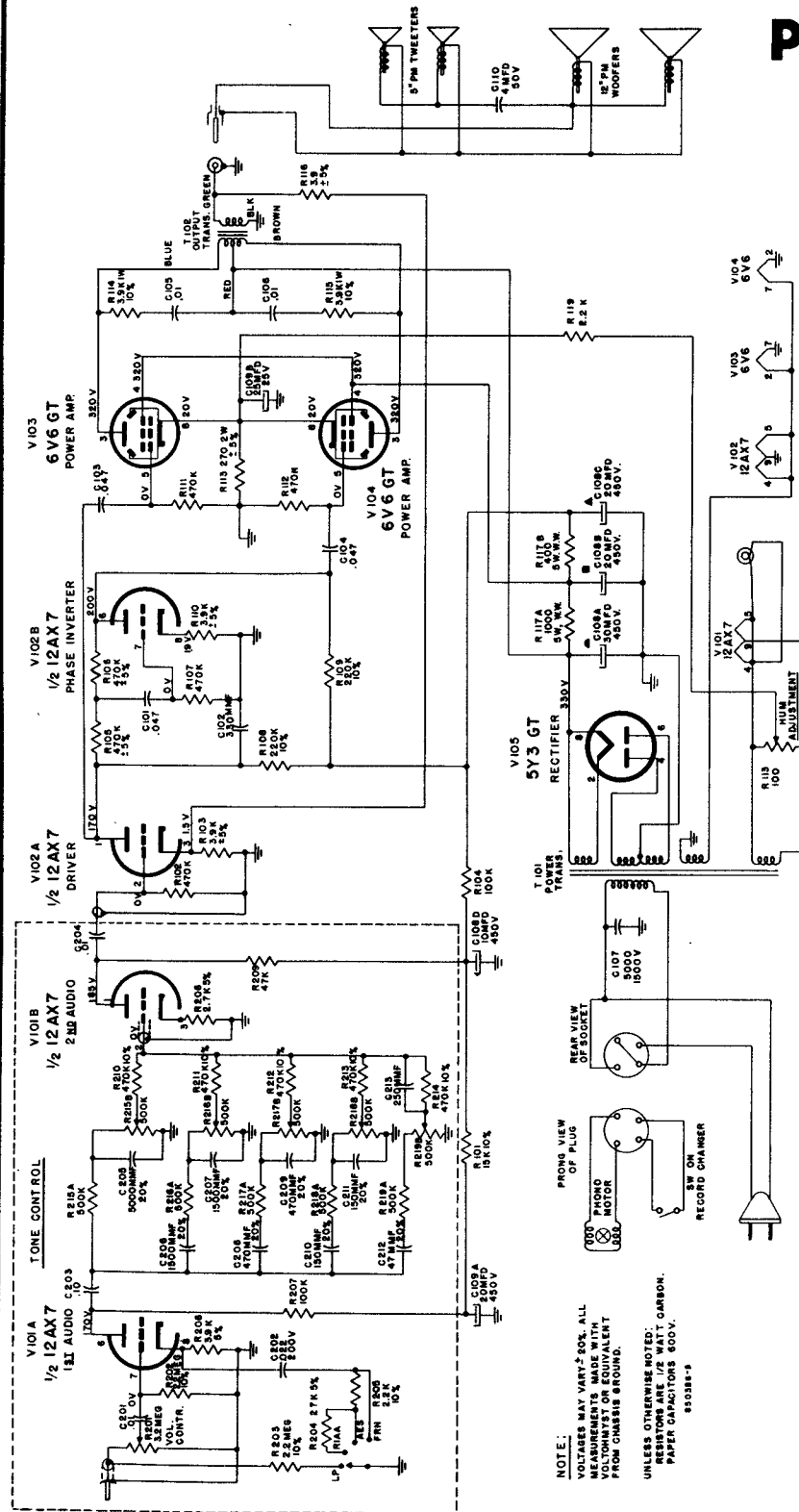

NOTE: VOLTAGES MAY VARY ± 50%. ALL MEASUREMENTS MADE WITH VOLTOHMIST OR EQUIVALENT FROM CHASSIS GROUND.
UNLESS OTHERWISE NOTED: RESISTORS—1% TOLERANCE, CARBON. CAPACITORS—50% TOLERANCE, PAPER CAPACITORS 300V.
510381-1

Removal of Chassis and Tone Control Assembly

- NOTE: If it is necessary to gain access to the Tone Control Assembly only, then steps 2 and 4 will suffice for the removal of this assembly.
1. Remove the knots, disconnect the speaker lead running to the amplifier, and disconnect the two connections between the record changer and amplifier.
 2. Remove the screws holding the panels to the cabinet directly in front of the changer. Remove the panels.
 3. Press down gently on the record changer and remove the two "C" washers on the record changer mounting screws. Remove the changer.
 4. Remove the screws holding the Tone Control Assembly to the cabinet.
 5. Remove the four bolts which fasten the Amplifier chassis to the cabinet.
 6. Re-insert the chassis and Tone Control Assembly by reversing the above procedure.

CBS

CBS-COLUMBIA
216 RADIO CHASSIS

MODELS T200, T201, T202, T203
& T204

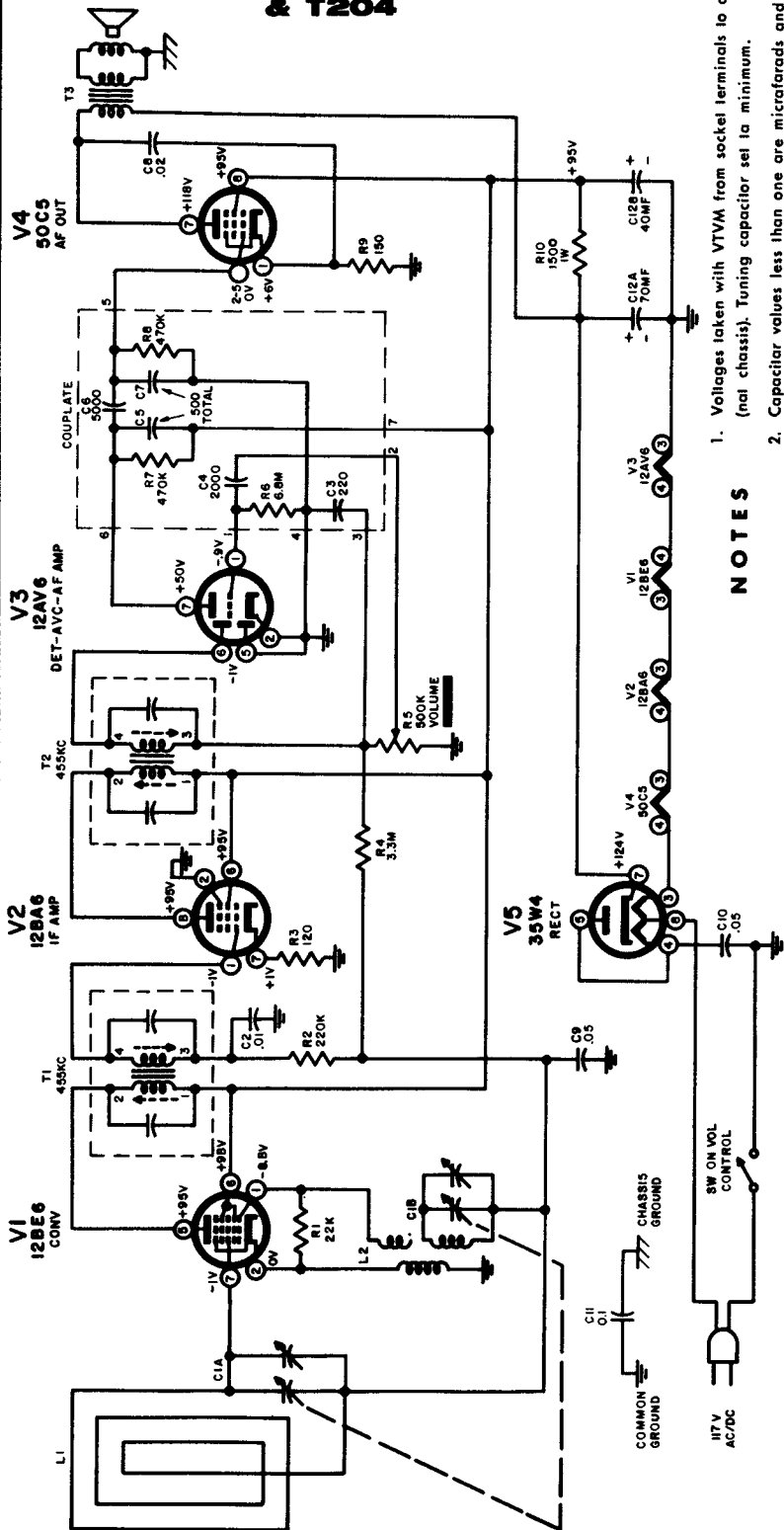

1. Voltages taken with VTVM from socket terminals to common ground (not chassis). Tuning capacitor set to minimum.
2. Capacitor values less than one are microfarads and values greater than one are micro-microfarads unless otherwise indicated.
3. Resistors are 1/2W, 10% unless otherwise indicated. K = X1,000; M = X1,000,000.

NOTES

Alignment

Set volume control to maximum. Adjust output of signal generator no higher than necessary for satisfactory indication. Use an insulated alignment tool.

Step	Signal Generator		Receiver Tuning	Output Meter Connection	Adjust
	Freq.	Connect to			
1	455KC MOD.	Pin 1 of V2, 12BA6, thru .05 mf	Minimum capacity	Across voice coil	T2, top and bottom slugs, for maximum indication.
2	As above	Pin 7 of V1, 12BE6, thru .05 mf	As above	As above	T1, top and bottom slugs, for maximum indication.
3	1620KC MOD.	As above	As above	As above	C1B, oscillator trimmer, for maximum indication.
4	1400KC MOD.	Couple inductively to loop antenna	For maximum signal	As above	C1A, antenna trimmer, for maximum indication.

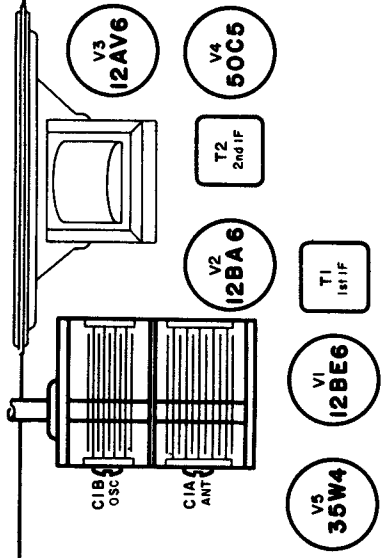

CBS

MODEL 5110

4P2 RADIO CHASSIS

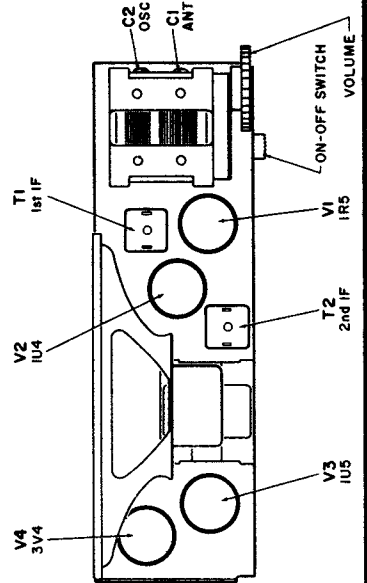
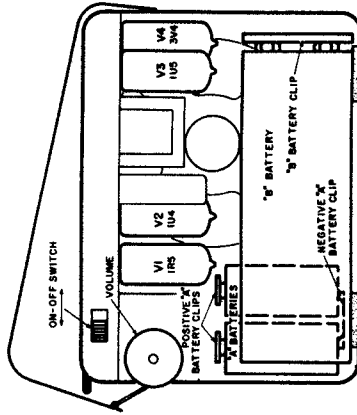
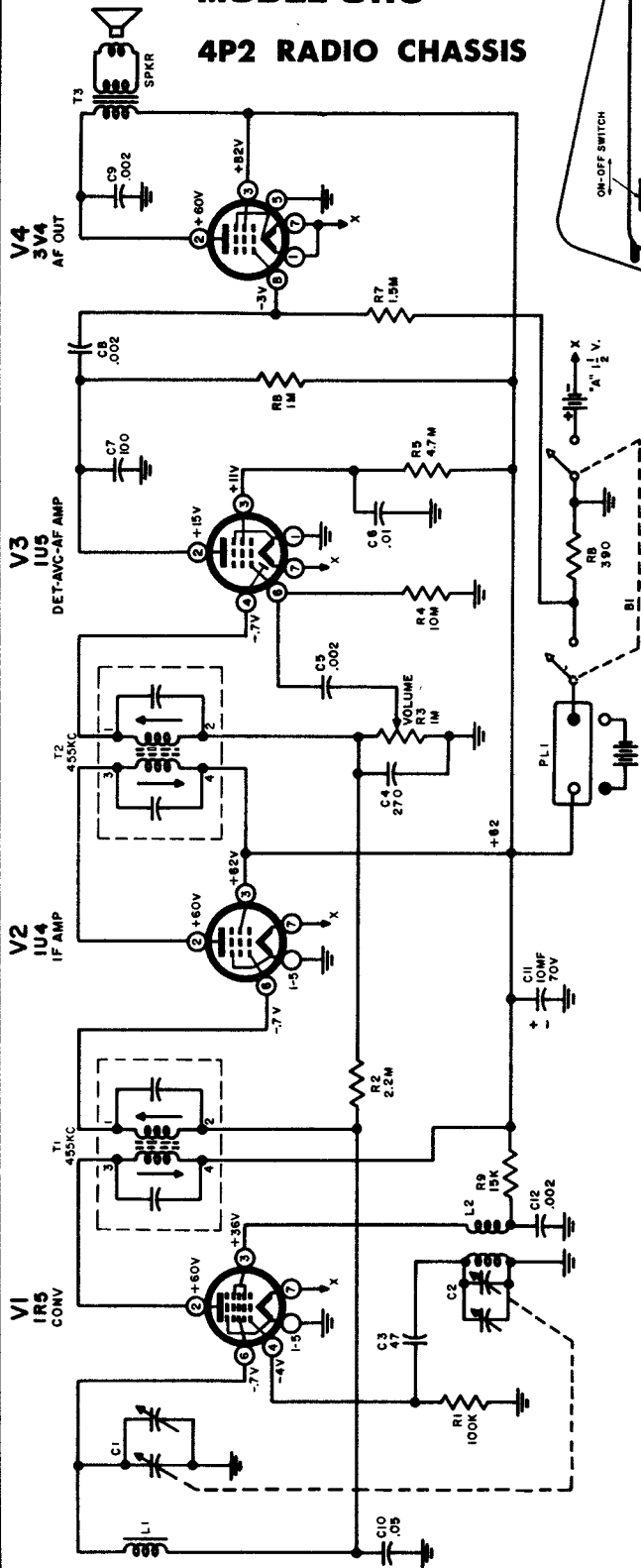

NOTES

1. I-F—455KC
2. Voltage readings taken with VTVM from tube socket terminals to chassis. Turning capacitor set to minimum.
3. Capacitor values less than one are microfarads and values more than one are micro-microfarads, unless otherwise indicated.
4. All resistors are 1/2 W, 20%. K = X1,000; M = X1,000,000.

Alignment

Step	Signal Generator		Receiver Tuning	Output Meter Connection	Adjust
	Freq.	Connect to			
1	455KC MOD.	Pin 6 of 1U4 thru .05 mf	Minimum capacity	Across voice coil	T2, top and bottom slugs, for maximum reading.
2	As above	Pin 6 of 1R5 thru .05 mf	As above	As above	T1, top and bottom slugs, for maximum reading.
3	1620KC MOD.	As above	As above	As above	C2, oscillator trimmer, for maximum reading.
4	1400KC MOD.	Inductively coupled to Ferrite loop	For maximum signal	As above	C1, antenna trimmer, for maximum reading.

CBS

MODEL 5220

4P1 RADIO CHASSIS

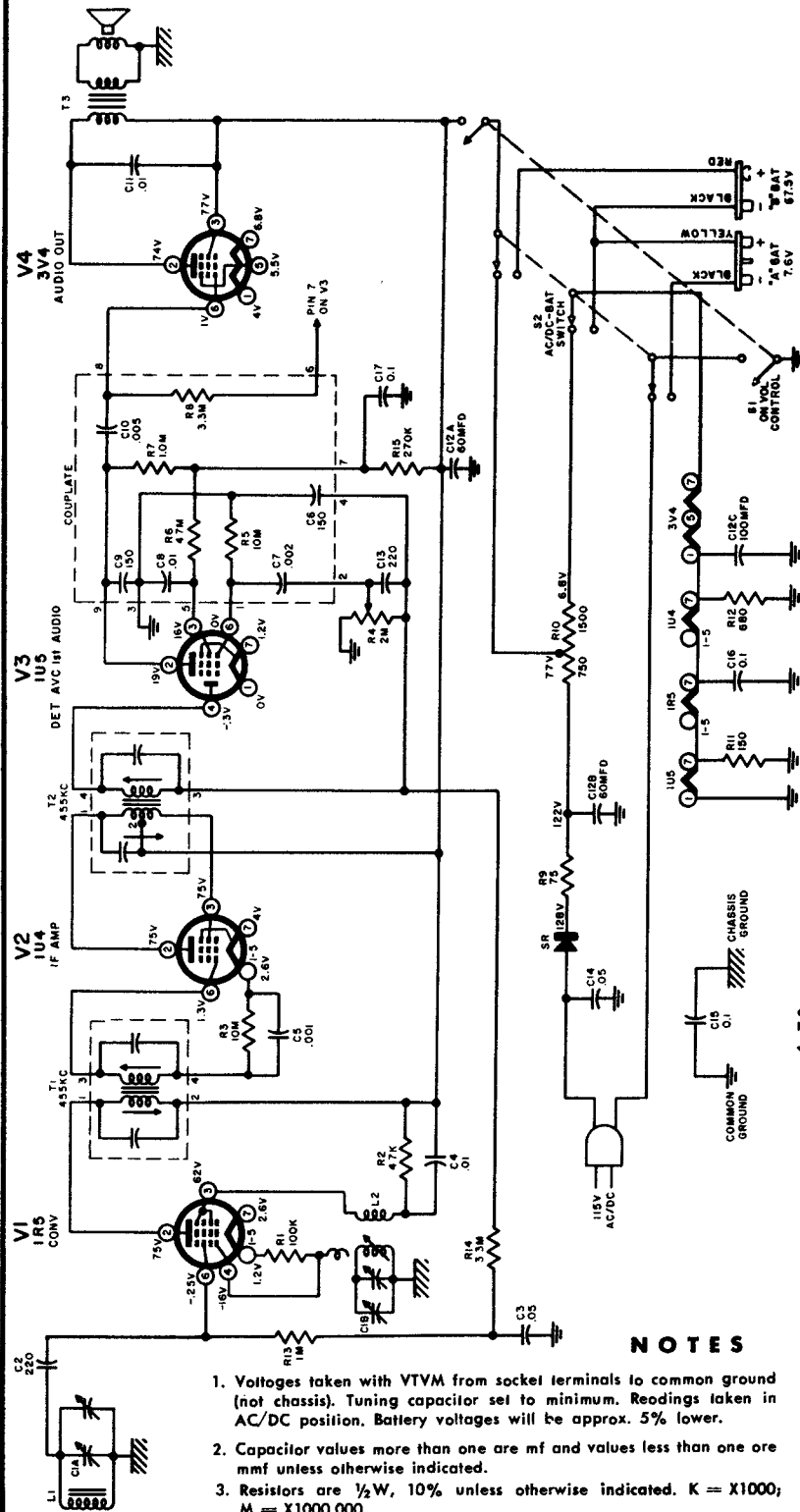
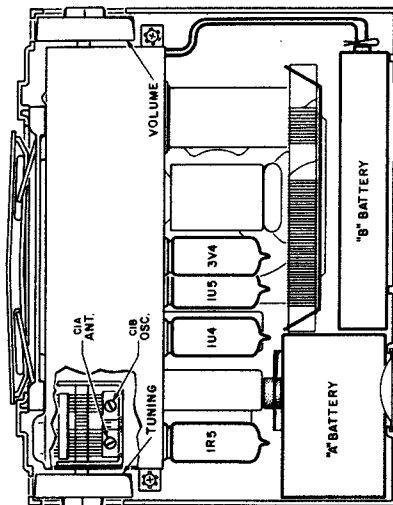

NOTES

1. Voltages taken with VTVM from socket terminals to common ground (not chassis). Tuning capacitor set to minimum. Readings taken in AC/DC position. Battery voltages will be approx. 5% lower.
2. Capacitor values more than one are mf and values less than one are mmf unless otherwise indicated.
3. Resistors are 1/2W, 10% unless otherwise indicated. K = X1000; M = X1000,000.

Set Volume Control to maximum. Adjust output of Signal Generator no higher than necessary for satisfactory indication. Use an insulated alignment tool.

Alignment

Step	Signal Generator		Receiver Tuning	Output Meter Connection	Adjust
	Freq.	Connect to			
1	455KC MOD.	Pin 6 of 1U4 thru .05 mf	Minimum capacity	Across voice coil	T2, top and bottom slugs, for maximum indication.
2	As above	Pin 6 of 1R5 thru .05 mf	As above	As above	T1, top and bottom slugs, for maximum indication.
3	1620KC MOD.	As above	As above	As above	C1B, oscillator trimmer, for maximum indication.
4	1400KC MOD.	Inductively coupled to loop antenna	For maximum signal	As above	C1A, antenna trimmer, for maximum indication.

CBS

CBS-COLUMBIA - MODEL 5440

5C4 CLOCK RADIO CHASSIS

(See next page, adjacent at right, for alignment information and additional service material.)

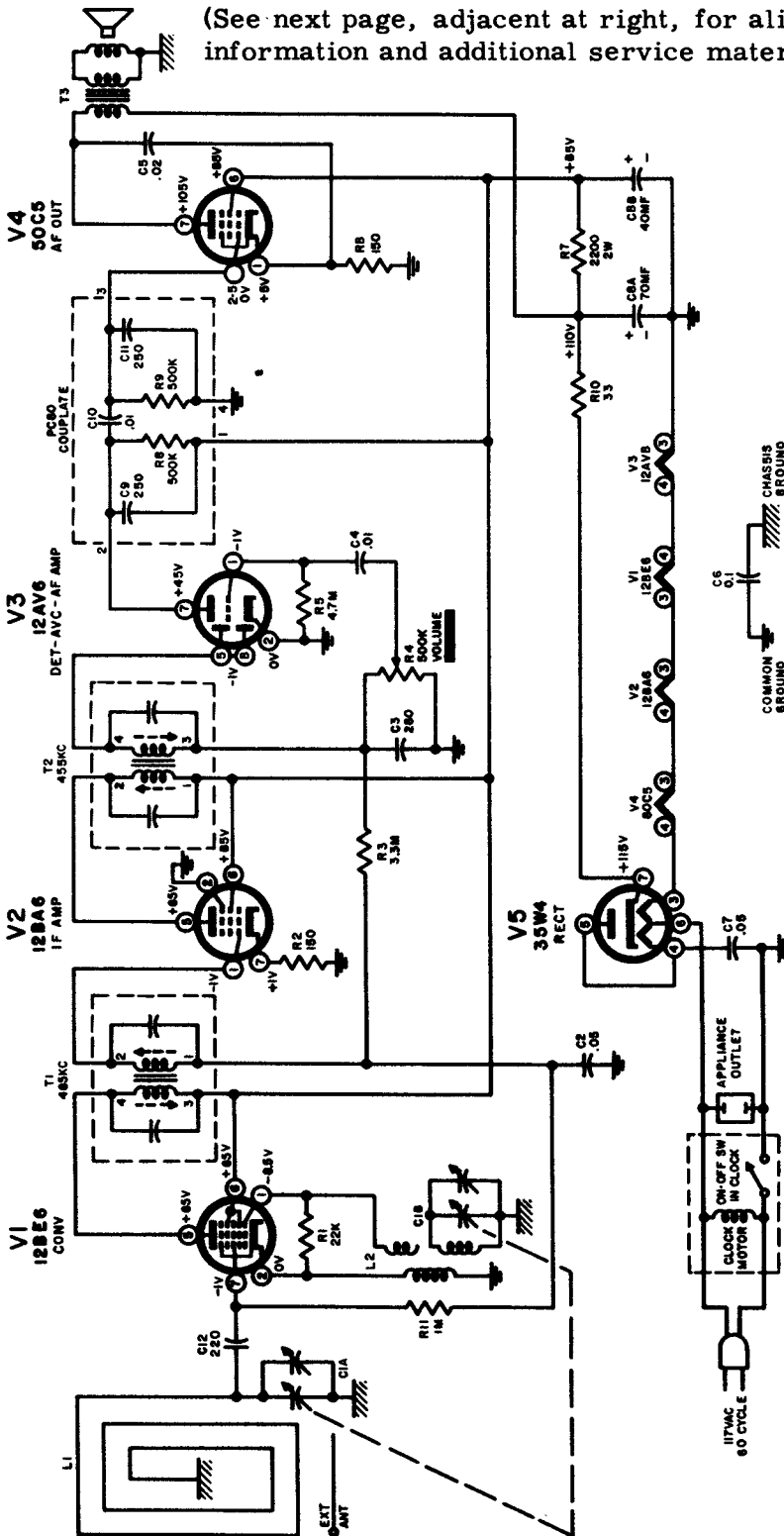

RESISTANCE READINGS

Sym.	Type	Pin 1	Pin 2	Pin 3	Pin 4	Pin 5	Pin 6	Pin 7
V1	12BE6	22K	1	24	12	*2.2K	*2.2K	4.8M
V2	12BA6	3.8M	0	24	36	*2.2K	*2.2K	150
V3	12AV6	4.7M	0	0	12	.5M	.5M	*.5M
V4	50C5	1.50	.5M	36	80	.5M	*2.2K	*2.50
V5	35W4	*33	*33	80	105	105	95	*0

Resistances in Ohms. K=X1,000; M=X1,000,000.
*Measured from socket terminal to cathode, pin 7, 35W4. All other readings to B-.

NOTES

1. Voltages taken with VTVM from socket terminals to common ground (not chassis). Tuning capacitor set to minimum.
2. Capacitor values less than one are microfarads and values greater than one are micro-microfarads, unless otherwise indicated.
3. Resistors are 1/2W, 10% unless otherwise indicated. K=X1,000; M=X1,000,000.
4. When using AC operated test equipment connect an isolation transformer between the receiver and the power line.

CBS-COLUMBIA - A Division of the Columbia Broadcasting System

CBS Model 5440, Clock Radio Chassis 5C4 (Continued)

Alignment

Set volume control to maximum. To prevent overloading use lowest range available on output meter and adjust output of signal generator to the minimum level necessary for satisfactory indication. Use an insulated alignment tool for all adjustments.

B— is connected directly to one side of the power line. When using AC operated test equipment connect an isolation transformer between the receiver and the power line. If an isolation transformer is not available connect a .1 mf capacitor in series with the signal generator ground lead and B—. Do not connect a ground lead directly to B—.

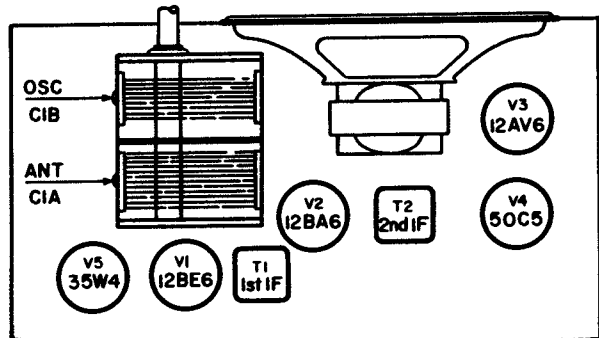

Tube and Trimmer Locations

Step	Signal Generator		Receiver Tuning	Output Meter Connection	Adjust
	Freq.	Connect to			
1	455KC MOD.	Pin 1 of V2, 12BA6, thru .05 mf	Minimum capacity	Across voice coil	T2, top and bottom slugs, for maximum indication.
2	As above	Pin 7 of V1, 12BE6, thru .05 mf	As above	As above	T1, top and bottom slugs, for maximum indication.
3	1620KC MOD.	As above	As above	As above	C1B, oscillator trimmer, for maximum indication.
4	1400KC MOD.	External antenna connection of loop antenna	For maximum signal	As above	C1A, antenna trimmer, for maximum indication.

(See preceding page, adjacent at left, for circuit diagram and other service material.)

Parts List

Capacitors

Symbol	Part No.	Description
C1A, B	24 000 221	Variable
C2	22 011 740	Paper, .05 mfd, 400V, 20%
C3	23 001 660	Cer., 220 mmfd, 500V, 20%
C4	22 011 660	Paper, .01 mfd, 400V, 20%
C5	22 011 700	Paper, .02 mfd, 400V, 20%
C6	22 026 280	Paper, .1 mfd, 400V, 20%
C7	22 011 740	Paper, .05 mfd, 400V, 20%
C8A, B	21 001 091	Elec., 70-40 mfd, 150V
C12	23 002 660	Cer., 220 mmfd, 500V, 20%

Resistors

R1	30 223 230	Carbon, 22K, 1/2W, 10%
R2	30 151 230	Carbon, 150 ohm, 1/2W, 10%
R3	30 335 230	Carbon, 3.3 Meg., 1/2W, 10%
R4	36 000 282	Volume Control, 500K
R5	30 475 230	Carbon, 4.7 Meg., 1/2W, 10%
R6	30 151 230	Carbon, 150 ohm, 1/2W, 10%
R7	30 222 250	Carbon, 2200 ohm, 2W, 10%
R10	30 330 230	Carbon, 33 ohm, 1/2W, 10%
R11	30 105 230	Carbon, 1 Meg., 1/2W, 10%

Miscellaneous

Symbol	Part No.	Description
L1	79 000 041	Loop Antenna & Back
L2	15 000 092	Oscillator Coil
T1, T2	12 000 281	Transformers, I.F.
	53 071 190	I.F. Trans. Mounting Clip
V1	61 000 461	Tube 12BE6
V2	61 000 291	Tube 12BA6
V3	61 000 471	Tube 12AV6
V4	61 000 491	Tube 50C5
V5	61 000 481	Tube 35W4
	73 000 102	Speaker, 4" PM, w/Trans. (T3)
	80 000 315	Line Cord, 6 ft. (#16 AWG)
	44 001 720	Appliance Outlet
	82 000 041	Couplate
	70 002 381	Cabinet, Ebony
	70 002 382	Cabinet, Maroon
	70 002 383	Cabinet, Sand
	70 002 384	Cabinet, Ivory
	76 000 694	Knob, Volume
	76 003 651	Knob, Tuning
	76 003 641	Clock
	74 000 491	Dial Plate

CROSLLEY

Chassis R100 and R101
 Models JT3BK, JT3GN, JT3IY, JT3RD,
 and JT4BK, JT4GN, JT4IY, JT4RD.

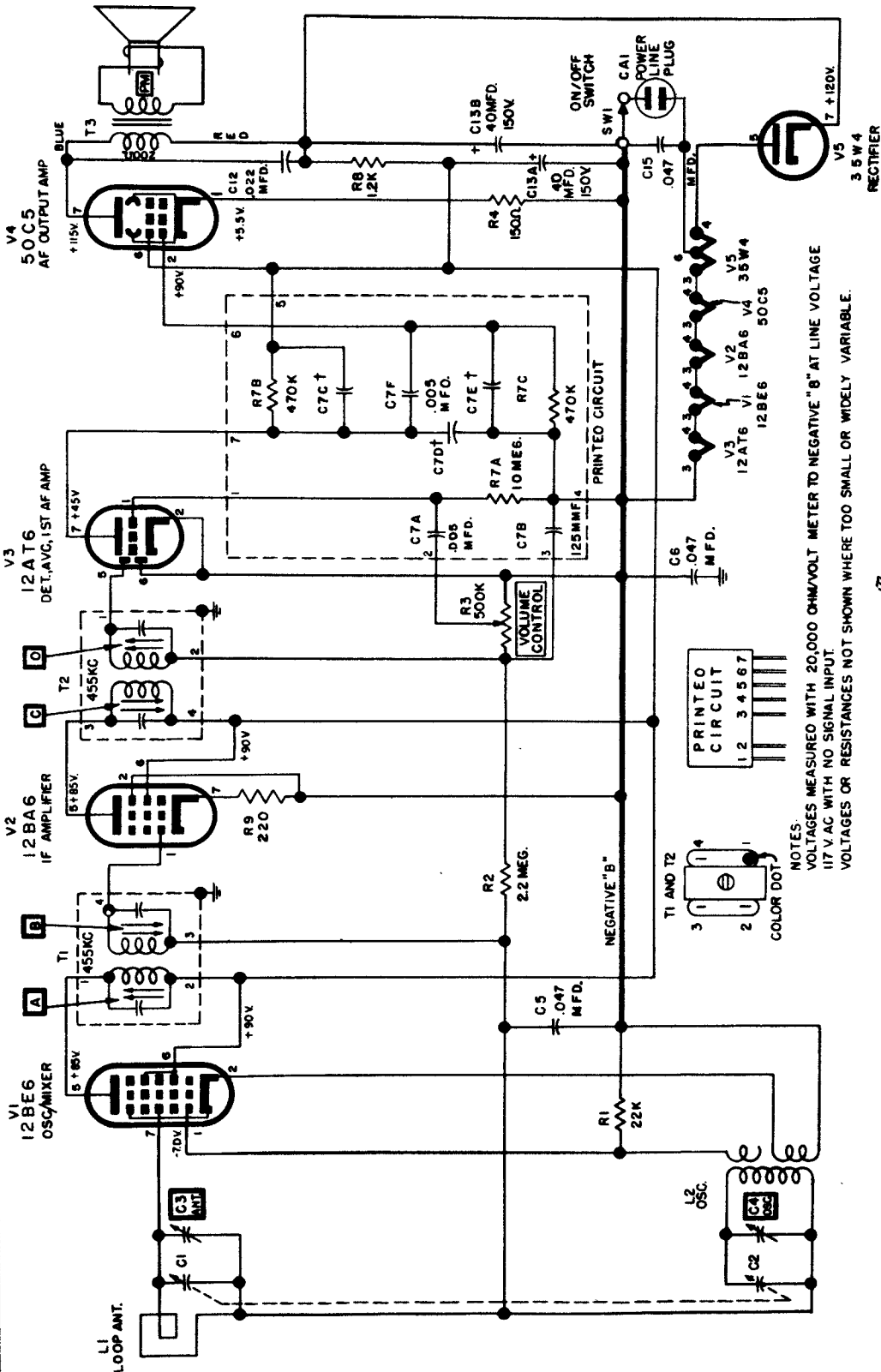

COIL RESISTANCES ARE AVERAGE VALUES.
 INTERMEDIATE FREQUENCY 455 KC.
 † COMBINED VALUE OF C7C, C7D, & C7E EQUALS 100 MMF.
 ‡ DESIGNATES CHASSIS GROUND.
 K = 1000

NOTES:
 VOLTAGES MEASURED WITH 20,000 OHM/VOLT METER TO NEGATIVE "B" AT LINE VOLTAGE
 117 V. AC WITH NO SIGNAL INPUT.
 VOLTAGES OR RESISTANCES NOT SHOWN WHERE TOO SMALL OR WIDELY VARIABLE.

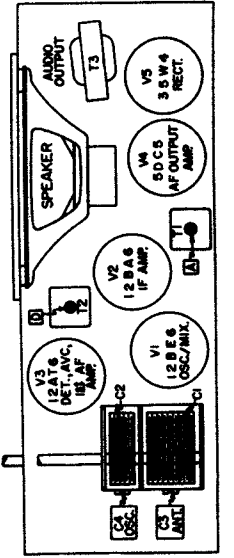
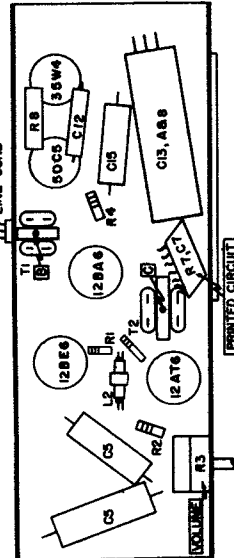

CROSLEY

CHASSIS R103

Models JC-6BK, JC-6BN, JC-6TN,
JC-6WE

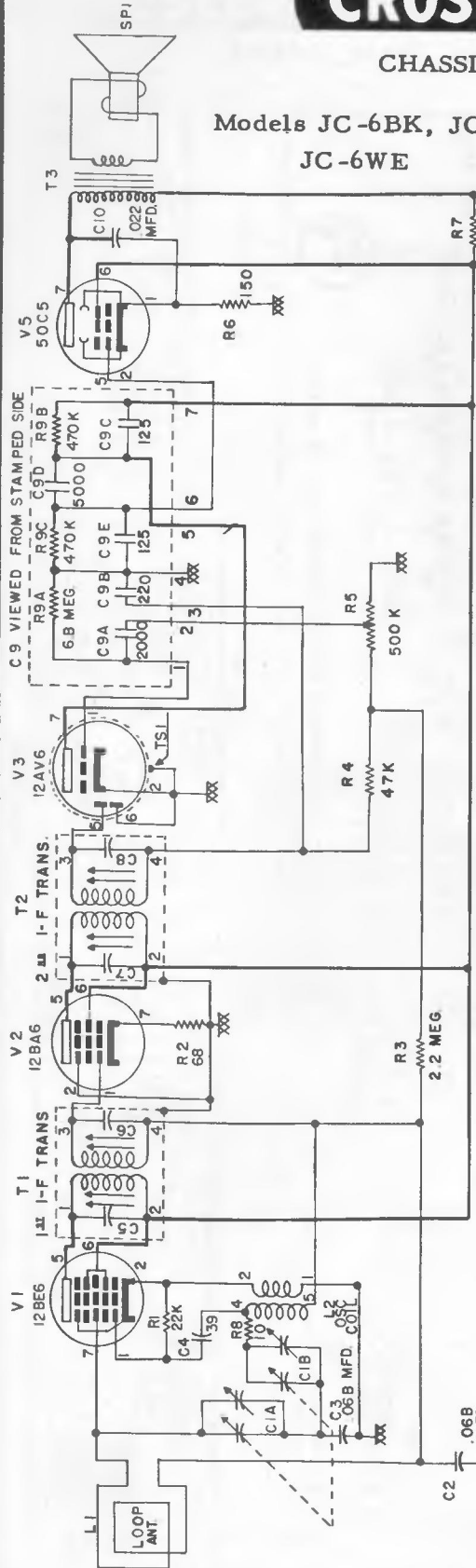

For alignment information see
the adjacent page to the right.

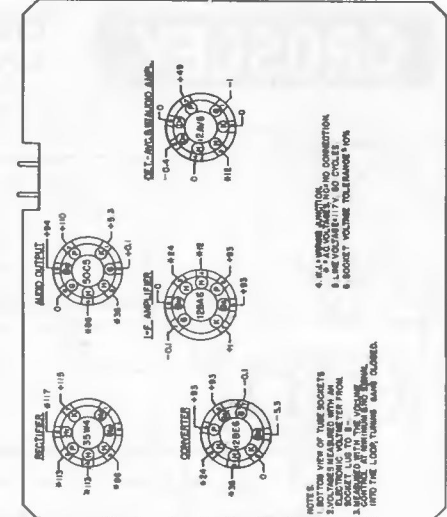
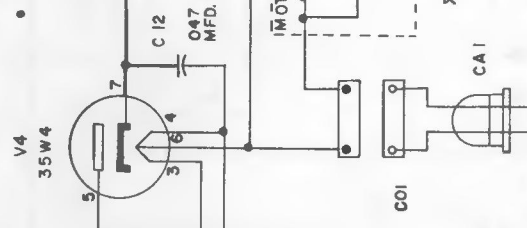
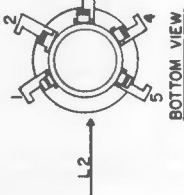

NOTE:
1. BOTTOM VIEW OF TUBE SOCKETS
2. ALL RESISTANCE VALUES IN OHMS, AND ALL CAPACITANCE VALUES IN P.F. UNLESS OTHERWISE NOTED.
3. NUMBERS IN CIRCLES INDICATE TRANSFORMER CORES CODED WITH GREEN DOT.
4. I-F TRANSFORMERS PROGRESS CLOCKWISE
5. I-F 1,455 KC.
6. COMMON WIRING
7. SWITCH SW1 USED TO CONTROL OPERATION OF THE RADIO AS FOLLOWS:
A. MANUALLY BY SETTING THE RADIO SWITCH KNOB TO 'ON' OR 'OFF'.
B. THE RADIO SWITCH IN THE 'AUTO-RADIO' POSITION
C. AUTOMATIC ALARM AND RADIO START BY PRESET OF ALARM SET KNOB AND WITH AUTOMATIC STOP AFTER NO MORE THAN 15 MINUTES IN THE 'RADIO-ALARM' POSITION
D. AUTOMATIC STOP AFTER NO MORE THAN 15 MINUTES IN THE 'RADIO-ALARM' POSITION BY SETTING THE SLEEP CONTROL AND WITH THE RADIO SWITCH KNOB IN THE 'OFF' POSITION

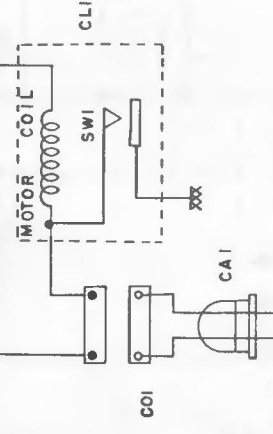

NOTE:
1. K = 1000. ALL TOLERANCES 20% UNLESS OTHERWISE NOTED.
2. ALL RESISTANCE VALUES IN OHMS, AND ALL CAPACITANCE VALUES IN P.F. UNLESS OTHERWISE NOTED.
3. NUMBERS IN CIRCLES INDICATE TRANSFORMER CORES CODED WITH GREEN DOT.
4. I-F 1,455 KC.
5. COMMON WIRING
6. SWITCH SW1 USED TO CONTROL OPERATION OF THE RADIO AS FOLLOWS:
A. MANUALLY BY SETTING THE RADIO SWITCH KNOB TO 'ON' OR 'OFF'.
B. THE RADIO SWITCH IN THE 'AUTO-RADIO' POSITION
C. AUTOMATIC ALARM AND RADIO START BY PRESET OF ALARM SET KNOB AND WITH AUTOMATIC STOP AFTER NO MORE THAN 15 MINUTES IN THE 'RADIO-ALARM' POSITION
D. AUTOMATIC STOP AFTER NO MORE THAN 15 MINUTES IN THE 'RADIO-ALARM' POSITION BY SETTING THE SLEEP CONTROL AND WITH THE RADIO SWITCH KNOB IN THE 'OFF' POSITION

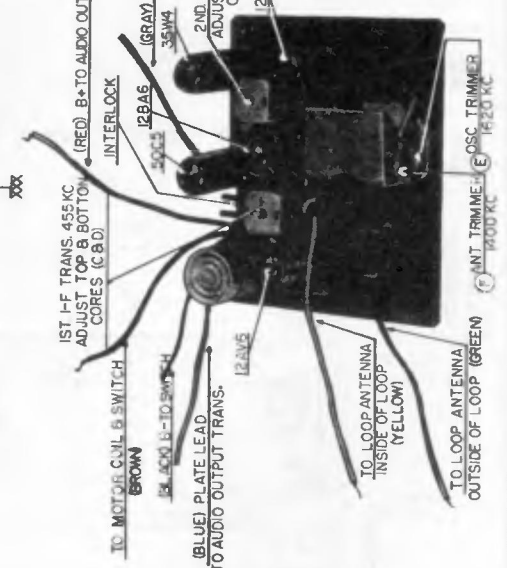

VOLUME R-16, MOST-OFTEN-NEEDED 1956 RADIO SERVICING INFORMATION

CROSLLEY Chassis R103 Alignment Information

Models:
 JC-6BN,
 JC-6BK,
 JC-6TN,
 JC-6WE.

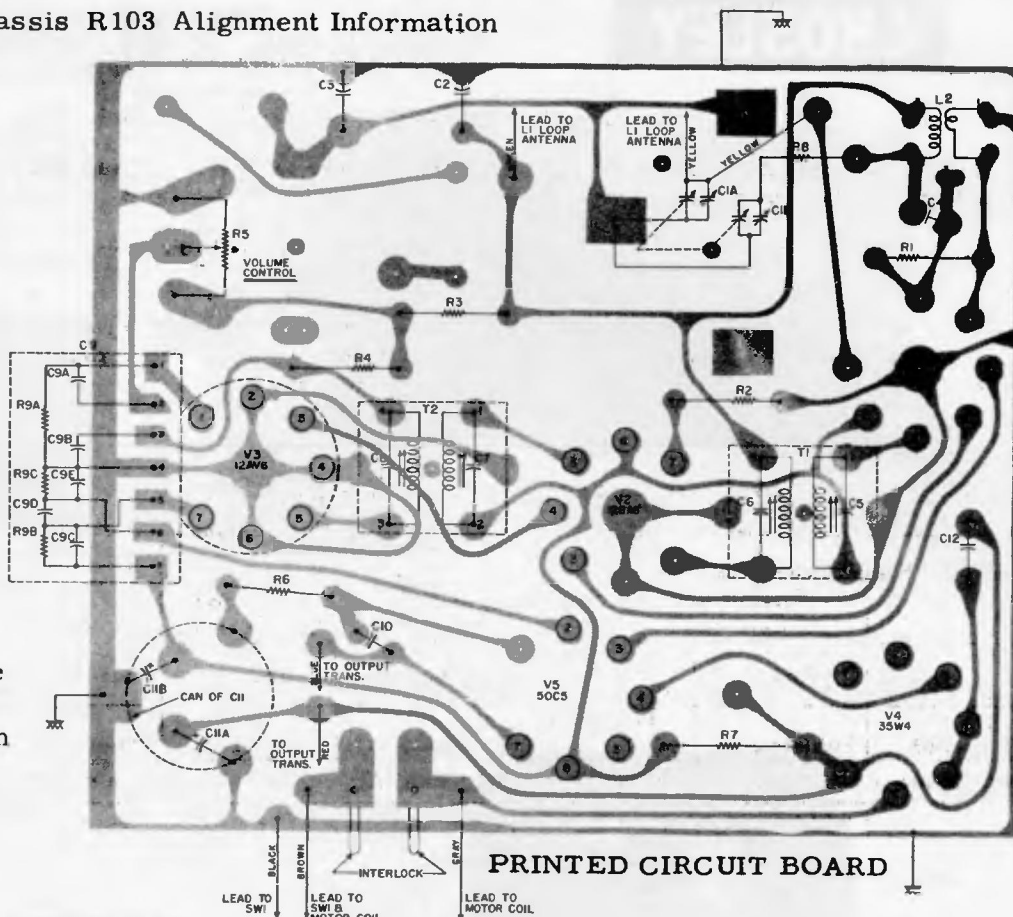

See the page at the left for circuit diagram and additional service data.

ALIGNMENT PROCEDURE

To operate set when it is removed from cabinet, connect switch leads (brown and black leads) together.

Turn the Volume Control to maximum clockwise position and adjust the signal generator output to produce approximately mid-scale deflection of the output meter, but maintain signal generator output as low as possible to prevent AVC action.

ALIGNMENT CHART

Alignment	Signal Generator Output			Position of Tuning Gang	Adjust for Max. Output	Remarks
	Freq. in KC.	In Series With	TO			
1	455	200 mmf.	Mixer grid pin 7 of V	Open	A & B	See note 1
2	455	200 mmf.	Mixer grid, pin 7 of V	Open	C & D	See note 1
3	Repeat steps 1 and 2 until maximum output is obtained.					See note 2
4	1620	Radiated Sig.	Antenna	Open	E	See note 3
5	1400	Radiated Sig.	Antenna	Tune in Signal	F	See note 3

1. Connect a 33,000 ohm resistor from mixer grid to B-. Disconnect loop to gang wire.
2. Connect loop to gang wire, remove 33,000 ohm resistor from mixer grid to B-.
3. The signal can be radiated to the antenna by placing the output lead of the signal generator close to the antenna

CROSLEY

CHASSIS R104 Models JC-8BK, JC-8BN, JC-8TN, JC-8WE

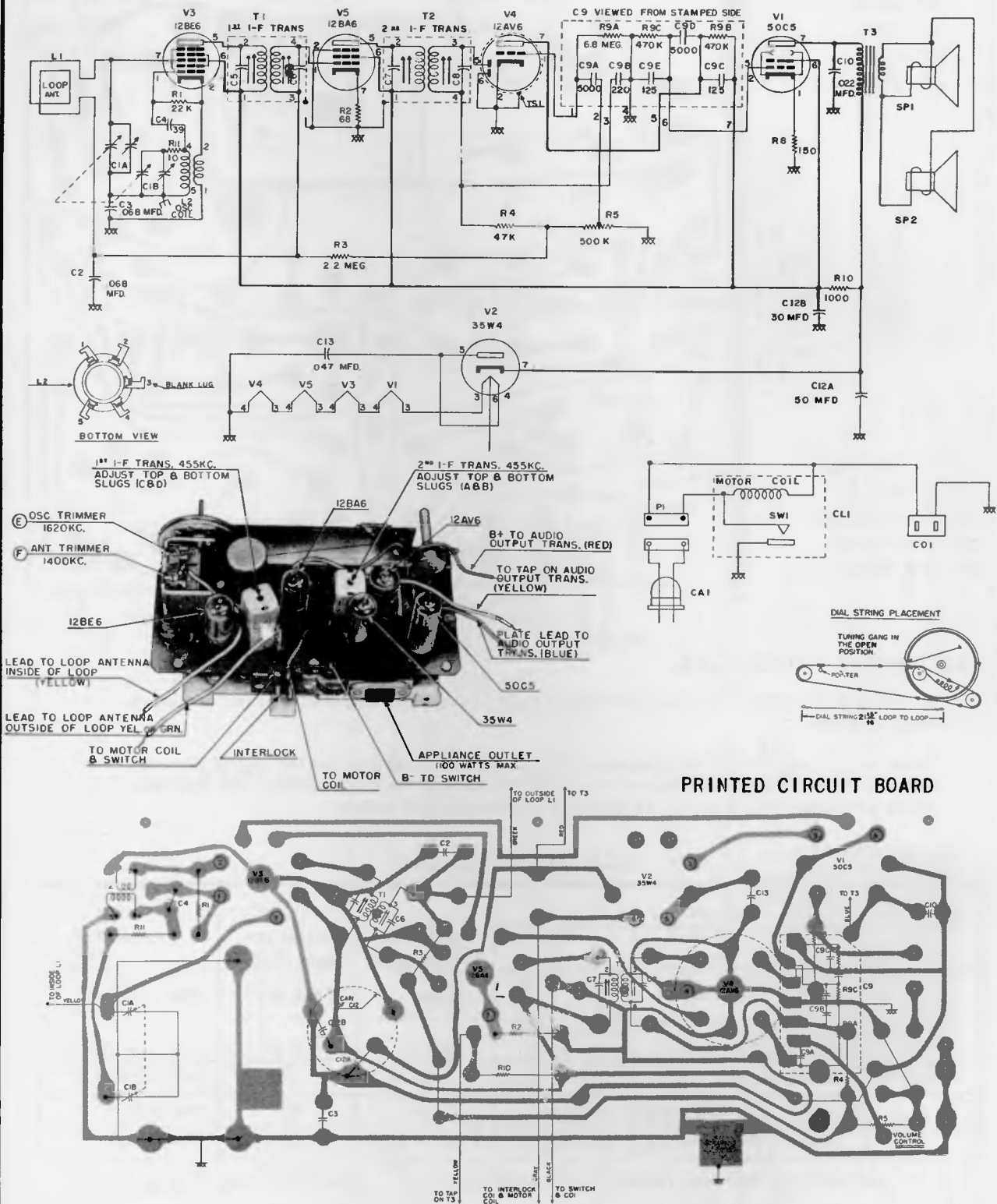

The Alignment Chart printed on the previous page for Chassis R103 is applicable also to this Chassis R104, and should be used with the top view photograph on this page.

CROSLLEY

Chassis R102

Models:

- JM-8BG JM-8GN
- JM-8BK JM-8MN
- JM-8BN JM-8WE



ON-OFF SWITCH PLUNGER

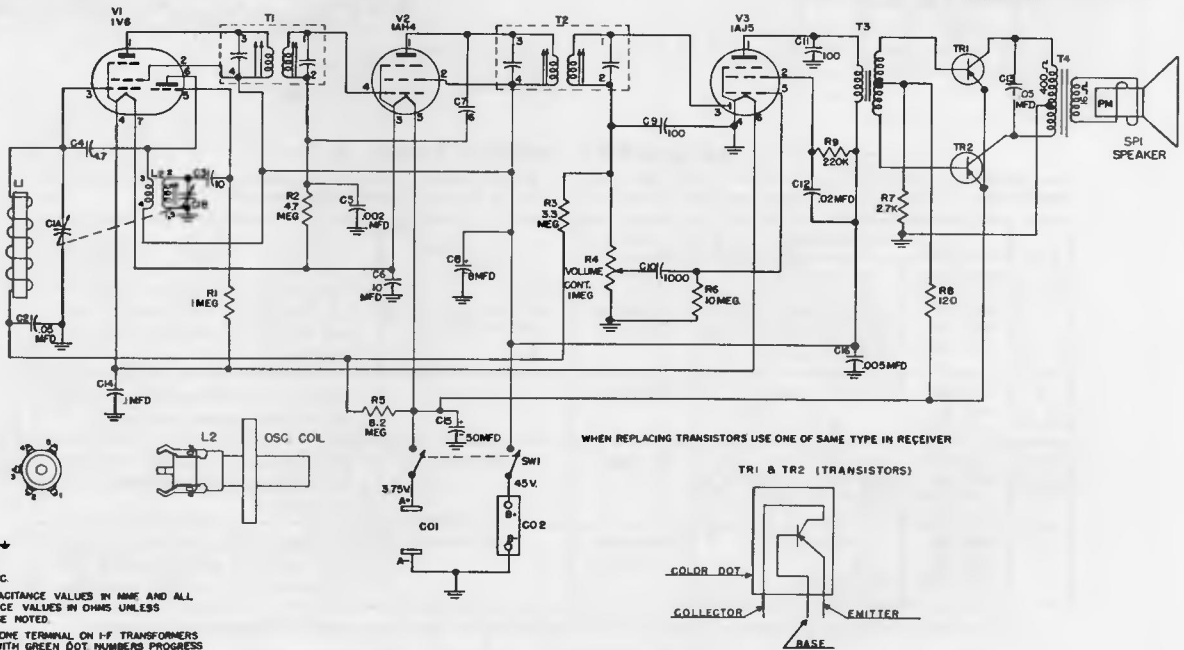
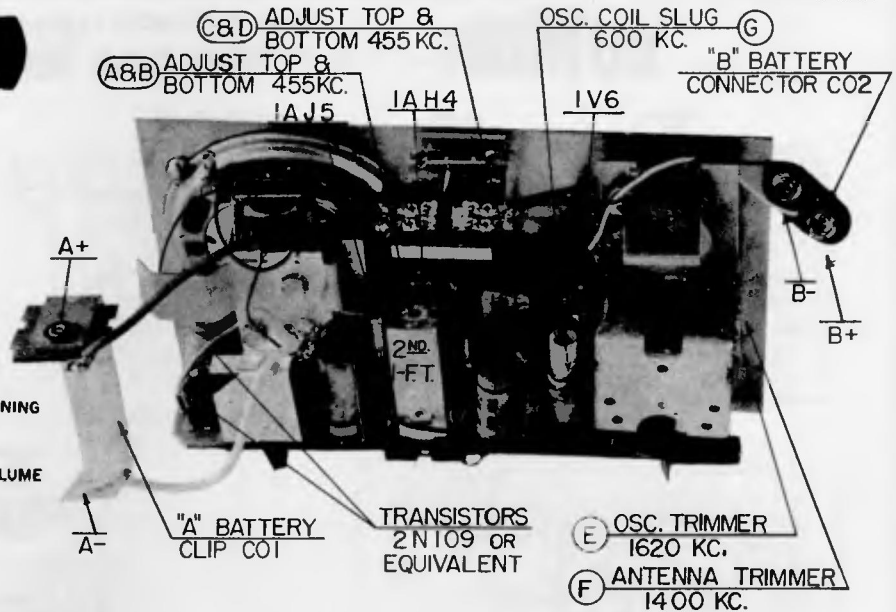

WHEN REPLACING TRANSISTORS USE ONE OF SAME TYPE IN RECEIVER

TR1 & TR2 (TRANSISTORS)

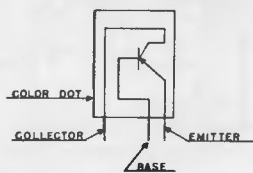

- NOTES:
1. CHASSIS
 2. K=1000
 3. F=455KC.
 4. ALL CAPACITANCE VALUES IN MMF AND ALL RESISTANCE VALUES IN OHMS UNLESS OTHERWISE NOTED.
 5. NUMBER ONE TERMINAL ON I-F TRANSFORMERS CODED WITH GREEN DOT NUMBERS PROGRESS CLOCKWISE.
 6. COLOR DOT ON SIDE OF TUBE INDICATES NO. 1 PIN.

SCHEMATIC WIRING DIAGRAM CHASSIS R102

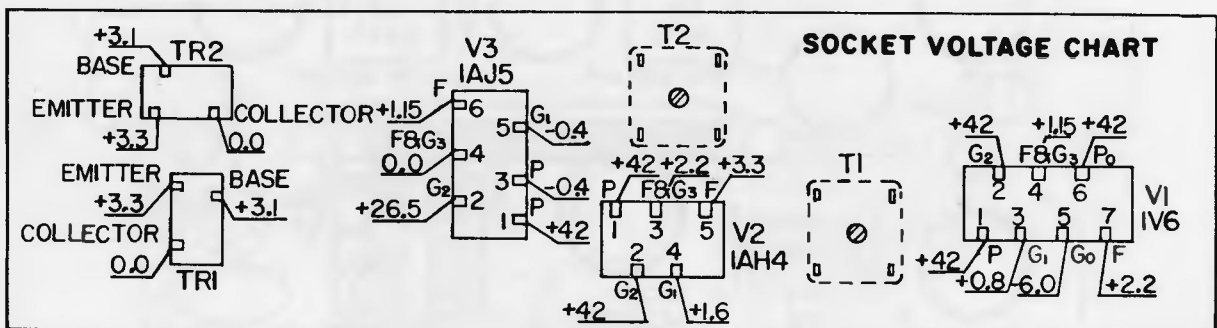

- NOTES:
1. BOTTOM VIEW OF TUBE SOCKETS.
 2. VOLTAGE MEASURED WITH AN ELECTRONIC VOLTMETER FROM SOCKET LUG TO CHASSIS.
 3. BATTERY SUPPLY VOLTAGE "A" BATTERY 3.3V. "B" BATTERY 42V.
 4. SOCKET VOLTAGE TOLERANCE ±10%.

DU MONT

ALLEN B. DU MONT LABORATORIES, INC.

RA-346 RADIO

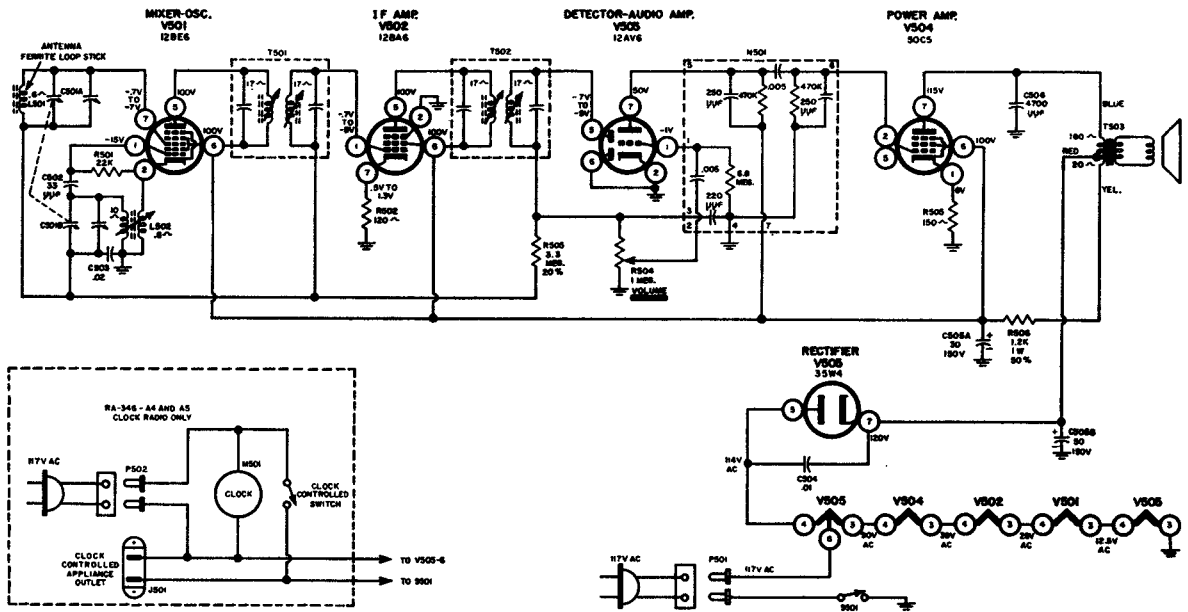

ALIGNMENT INSTRUCTIONS

Use an isolation transformer if available. Turn the volume control about 1/3 clockwise. Adjust the generator for the lowest

signal necessary to obtain an output reading. Make all adjustments with an insulated alignment tool.

Step	Signal Generator		Tuning Capacitor Setting	Output Meter Connection	Adjust
	Frequency	Connect to			
1	455 400 cps AM Mod.	Loop, of several turns of wire placed near AM antenna	Minimum Capacity	AC meter across speaker voice coil	I. F. Transformers T502 and T501 (top and bottom) for maximum output indication.
2	1640 KC 400 cps AM Mod.	As above	As above	As above	Oscillator trimmer capacitor of C501B for maximum output indication.
3	1640 KC 400 cps AM Mod.	Remove wire loop from AM antenna. Radiate a signal into the set	As above	As above	Antenna trimmer capacitor of C501A for maximum output indication. Re-check step 2.
4	540 KC 400 cps AM Mod.	As above	Maximum Capacity	As above	Oscillator tracking coil L502 for maximum output. Note: Disregard this step when L502 is a fixed inductance.

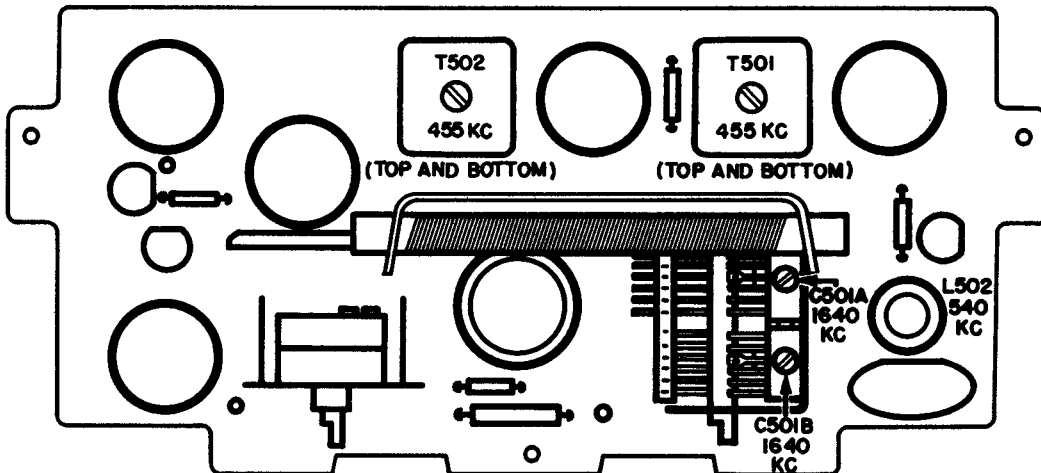

DU MONT

THE RA-349 TANGLEWOOD

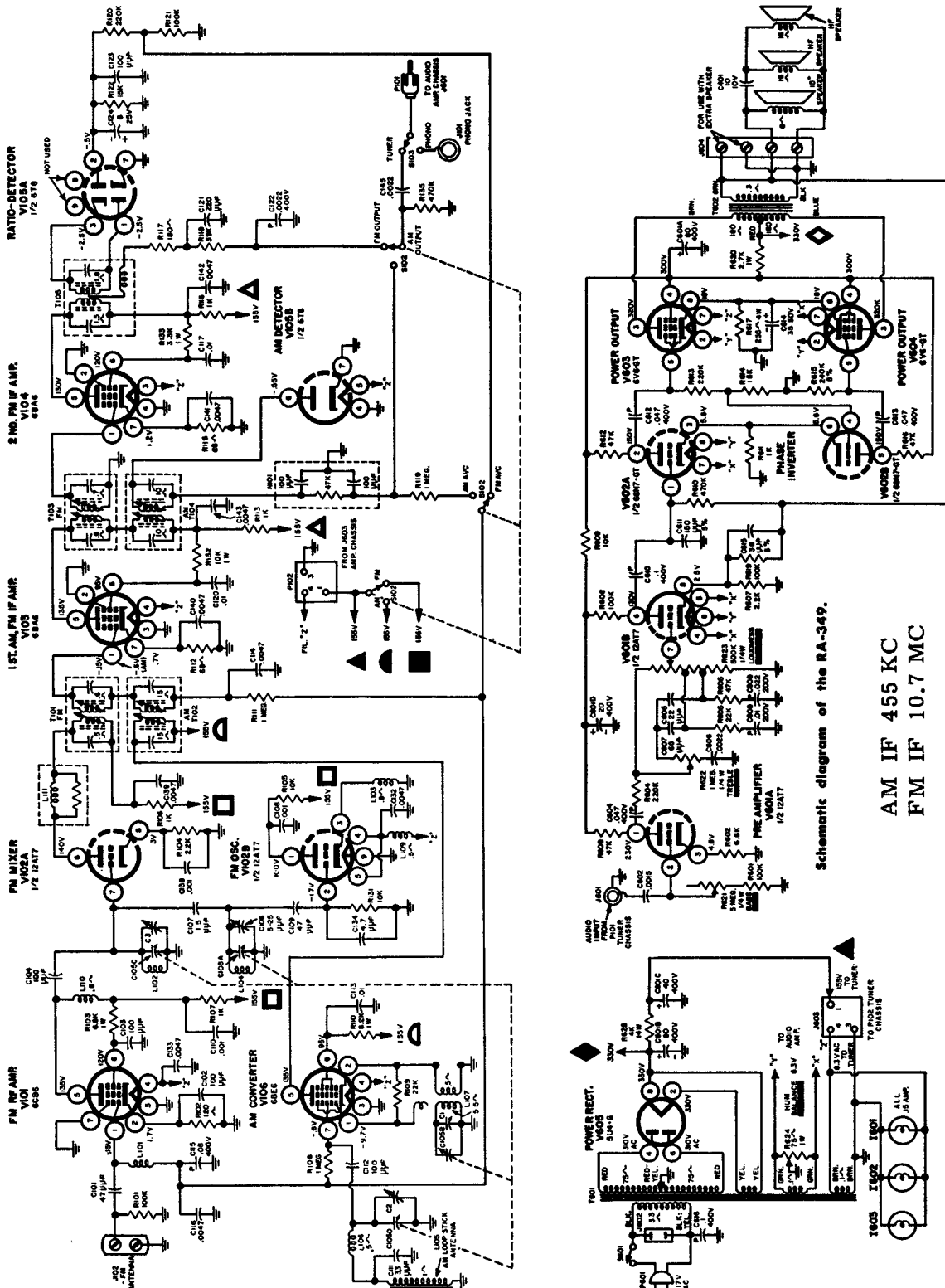

Schematic diagram of the RA-349.

AM IF 455 KC
FM IF 10.7 MC

EMERSON RADIO

MODELS - 818B, 836B

CHASSIS - 120159-B

AMPLIFIER CHASSIS

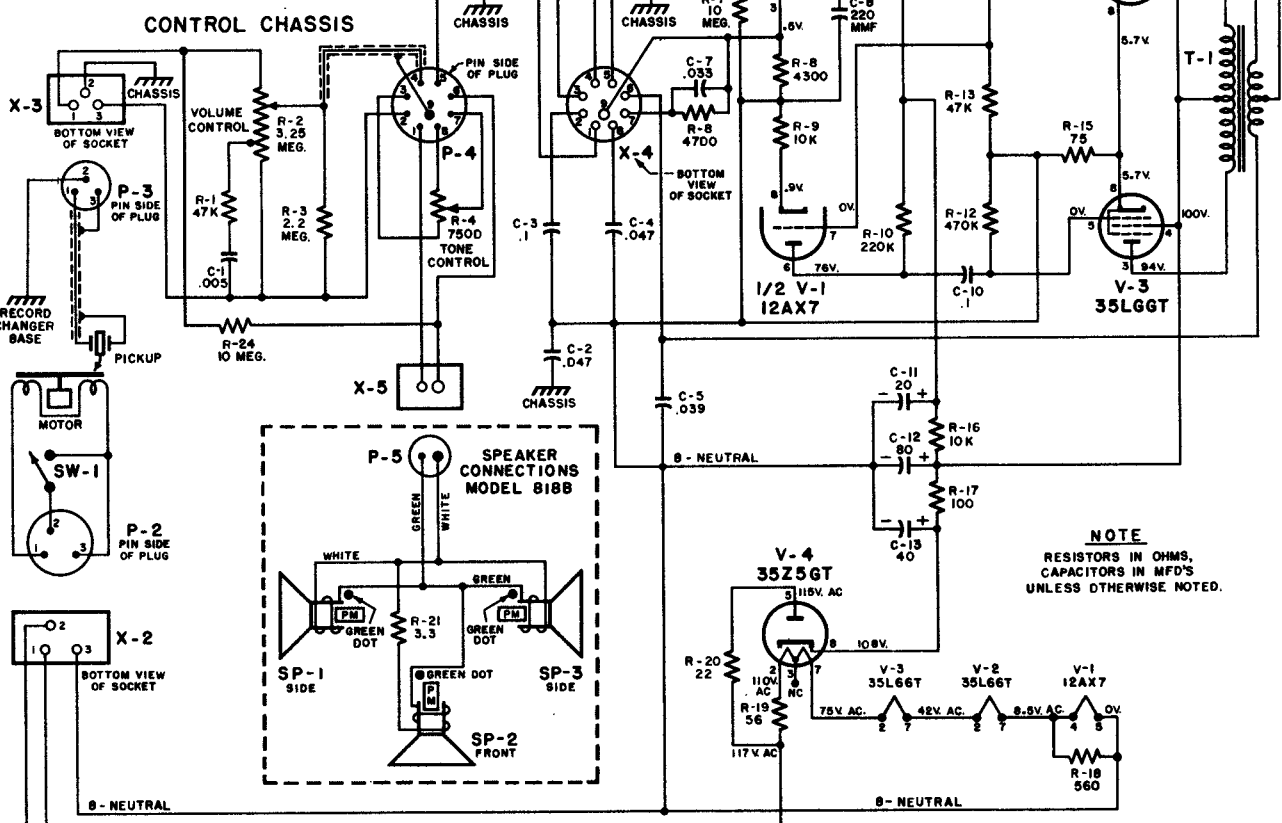

NOTE
RESISTORS IN OHMS,
CAPACITORS IN MFD'S
UNLESS OTHERWISE NOTED.

VOLTAGE READINGS ON SCHEMATIC DIAGRAM

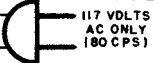

CONDITIONS FOR VOLTAGE AND RESISTANCE READINGS

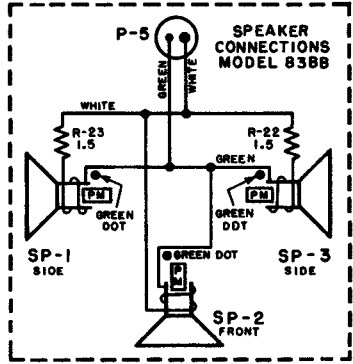
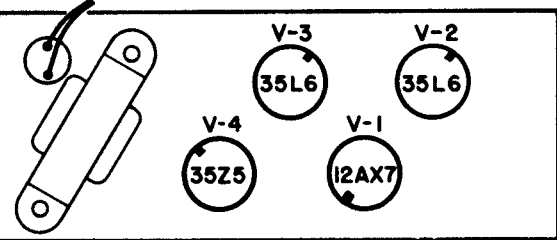

1. Voltages indicated are positive d.c., resistances in ohms, unless otherwise indicated.
2. Measurements made with voltohmmyst or equivalent.
3. All measurements taken from pin to B neutral unless otherwise indicated.
4. Voltage measurements taken under the following conditions:
 - a) Use adapter plug in socket X-2 shorting pins 2 and 3 only. This supplies a.c. to the amplifier without having to have the phono motor on, or the control chassis connected and in the "on" position.
 - b) Line voltage maintained at 117 volts a.c. only.
5. Resistance measurements taken with:
 - a) Power line cord disconnected from outlet.
 - b) Loudness control set for maximum volume.
6. Nominal tolerance on component values makes possible a variation of $\pm 15\%$ in voltage and resistance readings.
7. N.C. denotes no connection, K is kilohms, Meg. is megohms. Resistances marked * are measured to pin 8 of rectifier 35Z5GT (B+).

RESISTANCE READINGS FOR CHASSIS 120159-B REVISED

SYMBOL	TUBE	PIN 1	PIN 2	PIN 3	PIN 4	PIN 5	PIN 6	PIN 7	PIN 8
V-1	12AX7	230K*	10 meg.	4.3K	17	0	230K*	47K	10K
V-2	35L6GT	0	48	275*	100*	520K	N.C.	17	75
V-3	35L6GT	N.C.	80	290*	100*	470K	N.C.	48	75
V-4	35Z5GT	N.C.	115	110	N.C.	190	N.C.	80	HIGH

Emerson Radio

MODEL 832B

CHASSIS-120266-B

RESISTANCE READINGS FOR CHASSIS 120266-B

All measurements taken from pin to B neutral unless otherwise indicated.

TUBE	PIN 1	PIN 2	PIN 3	PIN 4	PIN 5	PIN 6	PIN 7
12BE6	22K	1.0	19.0	30.0	1075*	1050*	3.6 MEG
12BA6	15.0	0.0	22.0	35.0	1075*	1050*	120.
12AV6 or 12AT6	6.2 MEG	0.0	0	13.0	560K	0.0	420K*
50C5	160.	450K	36	85	450K	1050*	260*
35W4	N.C.	N.C.	80	120	120	110	0*

* Resistance measured to Pin 7 of Rectifier 35W4 (B+).

VOLTAGE READINGS ON SCHEMATIC DIAGRAM

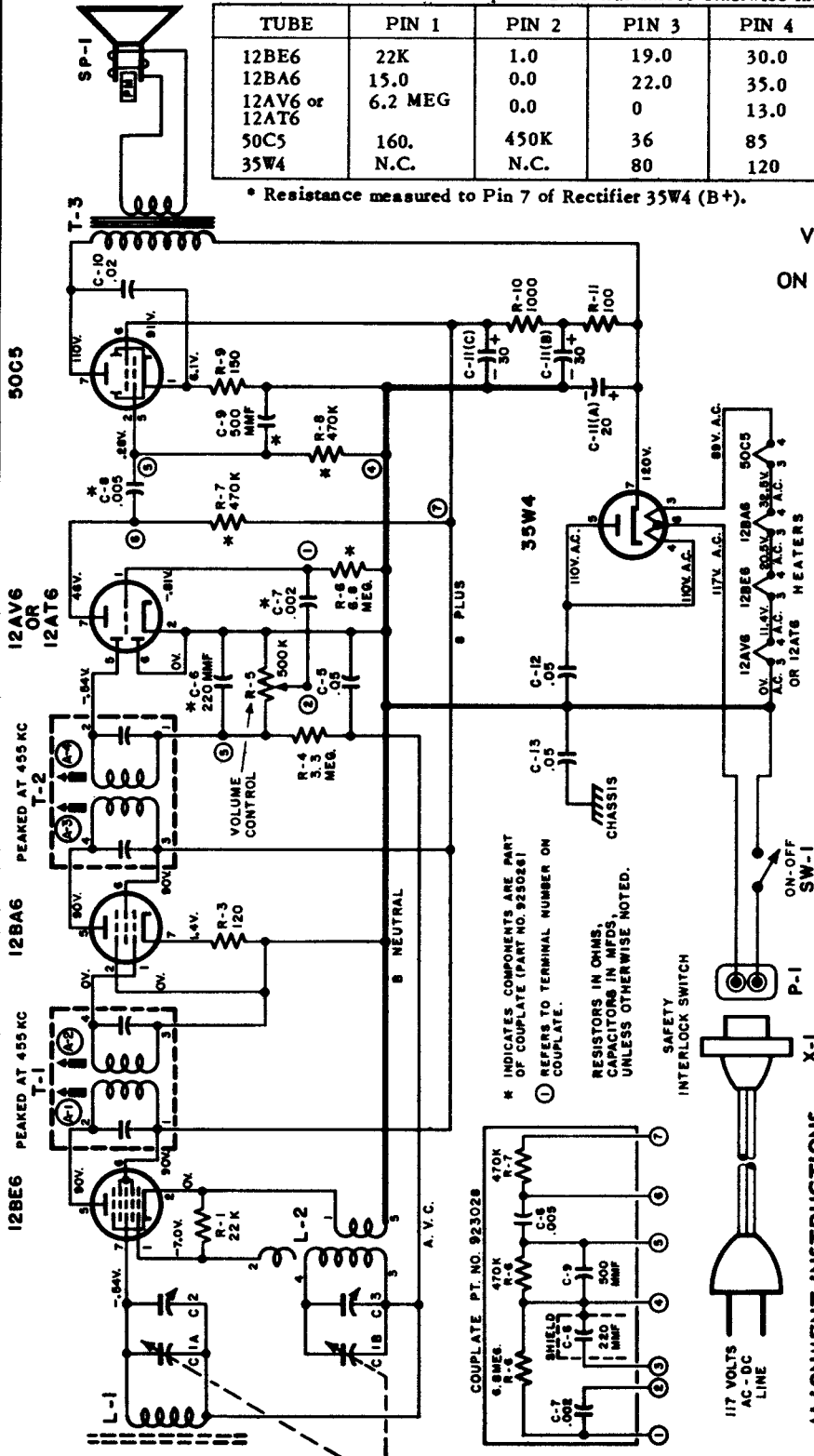

STEP	DUMMY ANTENNA	SIGNAL GENERATOR COUPLING	SIGNAL GENERATOR FREQUENCY	RADIO DIAL SETTING	OUTPUT METER	ADJUST	REMARKS
1	.005 mfd.	High side to grid (pin 7) of V1 (12BE6). Low side to	455 KC	Variable condenser fully open.	Across voice coil.	T2, T1 (A3, A4, A1, A2)	Adjust for maximum output.
2		Form loop of several turns and radiate signal into signal receiver	1620 KC	*	Across voice coil.	Trimmer C-3 (Osc.)	Adjust for maximum output.
3		*	1400 KC	Tune for maximum output.	Across voice coil.	Trimmer C-2 (Aut.)	Adjust for maximum output.

ALIGNMENT INSTRUCTIONS

Emerson Radio

MODEL 835A

CHASSIS 120271-A

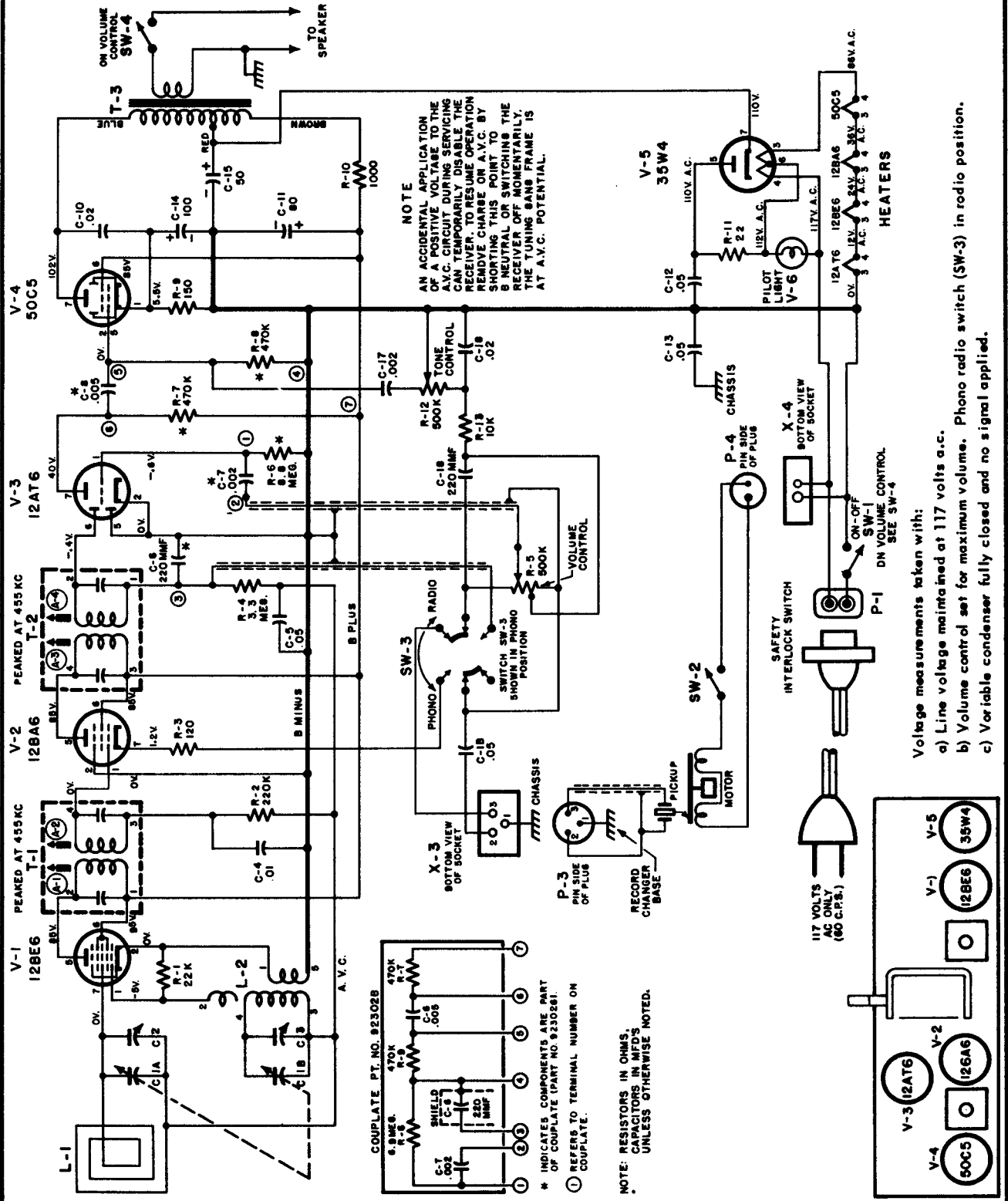

VOLUME R-16, MOST-OFTEN-NEEDED 1956 RADIO SERVICING INFORMATION

EMERSON RADIO Model 838, Chassis 120274

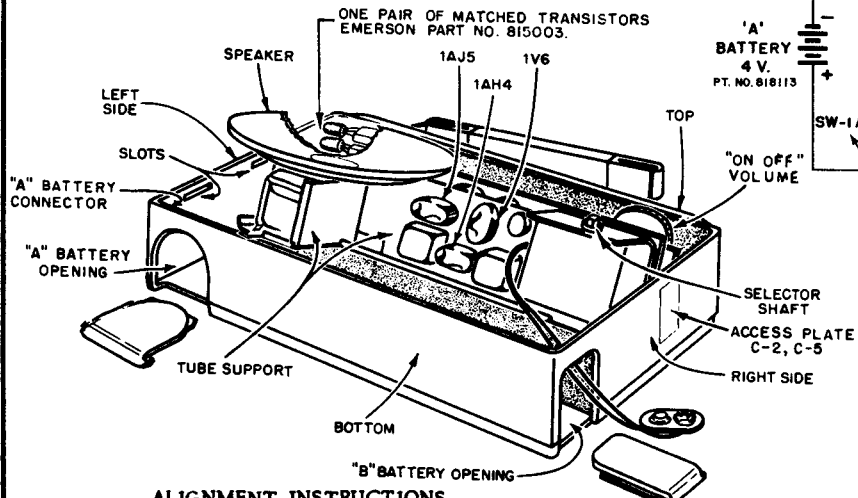
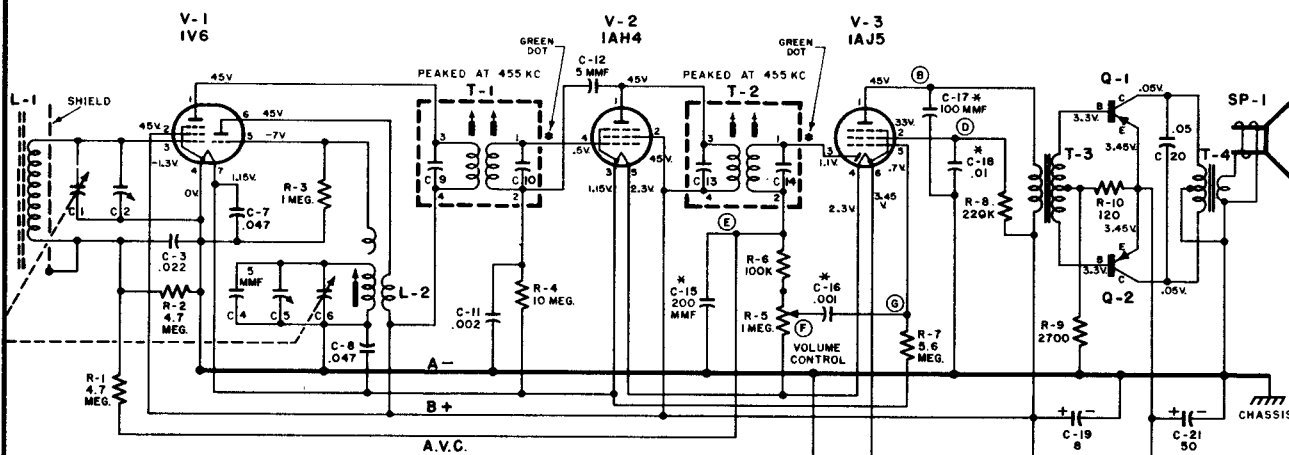

ALIGNMENT INSTRUCTIONS

Volume control should be at maximum; output of signal generator should be no higher than necessary to obtain an output reading.

NOTE: C-5, C-2, and L-2 must be adjusted with the chassis and batteries in the cabinet. C-5 and C-2 can be adjusted by removing a small plate on the side of the cabinet by pressing it out from the inside.

	DUMMY ANTENNA	SIGNAL GENERATOR COUPLING	SIGNAL GENERATOR FREQUENCY	RADIO DIAL SETTING	OUTPUT METER	ADJUST	REMARKS
1	.1 mfd.	High side to pin 3 (grid) of 1V6. Low side to chassis.	455 KC.	Tuning condenser fully open.	Across voice coil	T2 and T1	Adjust top and bottom of each for maximum output.
2		Use a loop set perpendicular and about 20" from center of bar loop ant. in set.	1640 KC.	Tuning condenser fully open.	Across voice coil	C-5 (osc. trimmer)	Fashion loop of several turns of wire and radiate signal into bar loop of receiver. Adjust for maximum output.
3		"	1400 KC.	Tune for maximum output.	Across voice coil.	C-2 (Ant. trimmer)	Adjust for maximum output.
4		"	600 KC.	Tuning condenser set for 600 KC.	Across voice coil.	Osc. slug in L-2	Rock the variable cond. each side of 600 KC while adj. osc. slug for maximum response.
5		"	1640 KC.	Tuning condenser fully open.	"	C-5 Osc. trimmer	If readjustment is necessary repeat steps 2 to 4 until no further improvement is noted.

* INDICATES COMPONENTS ARE PART OF COUPLATE (PT. NO. 923029).
 (B) REFERS TO TERMINAL LETTER ON THE COUPLATE.

NOTE: PIN NO. 1 IS NEXT TO THE RED DOT ON THE TOP SIDE OF TUBE SOCKET.
 RESISTORS IN OHMS, CAPACITORS IN MFDs, UNLESS OTHERWISE NOTED.

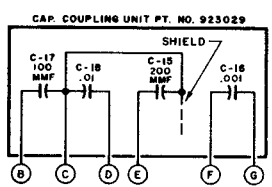

EMERSON RADIO

MODELS 834-B, 839B
CHASSIS 120270-B

MODEL - 841-A
CHASSIS 120291-A

CHASSIS NO. 120270-B

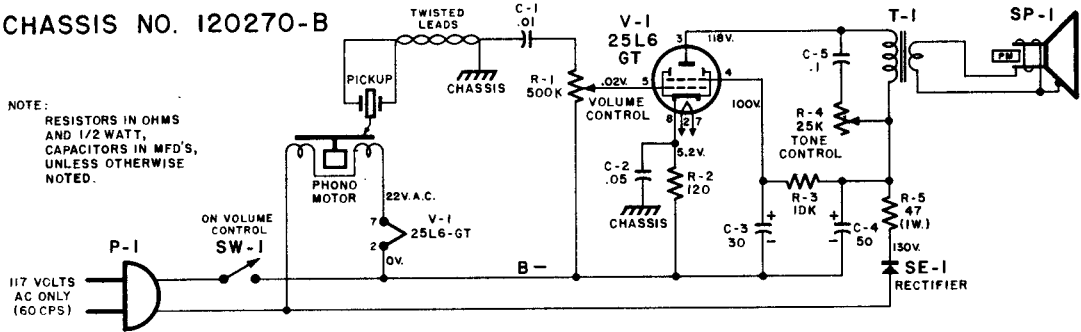

CHASSIS NO. 120291 - A

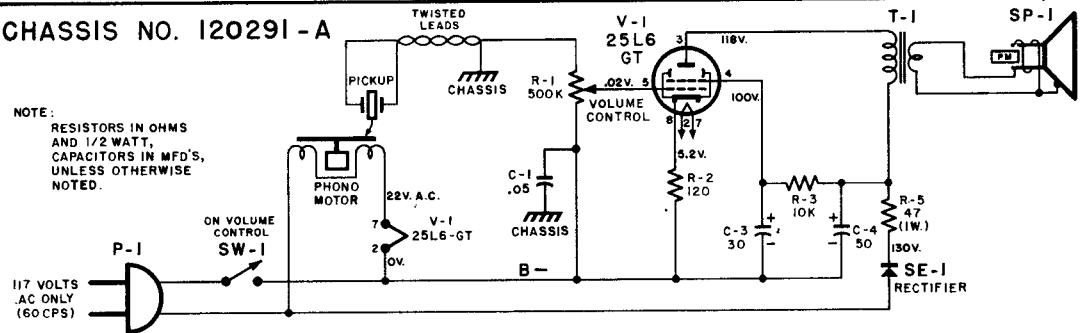

V.T.V.M OHMMETER CHECK OF TRANSISTORS

An approximate check of the transistors may be made with a vacuum tube type of ohmmeter. They are checked as two separate crystal diodes might be checked, that is, by measuring the forward and inverse resistance of each section individually. Figures No. 2 and No. 3 shows the method of testing P-N-P and N-P-N types of transistors used in this receiver.

When the negative terminal of the ohmmeter (set on R x 10 scale) is connected to the base (B) terminal of a good PNP transistor and the positive terminal of the meter is connected to the collector (C) or emitter (E) terminals, you should measure a low resistance (in the order of 500 ohms or less).

When the positive terminal of the ohmmeter is connected to the base (B) terminal of a good PNP transistor and the negative terminal of the meter is connected to the collector (C) or emitter (E) terminals, you should measure a high inverse resistance in the order of 50K ohms or higher.

In the event your results are opposite from these, it is possible that the plus side of your meter is actually connected to the negative side of its internal battery.

NPN type transistors are checked in a similar manner except the applied polarities from the ohmmeter are reversed (see figure no. 3) to give same inverse and forward resistance results.

CAUTION

Use only a vacuum tube type of ohmmeter. The R x 10 scale must be used for all forward (low) resistance measurements. Do not use the R x 1 scale as this might damage the transistor. A shunt type ohmmeter should not be used. If in doubt as to the type of vacuum tube ohmmeter you have, place a 1,000 ohm resistor in series with it and subtract this 1,000 ohms from the reading obtained.

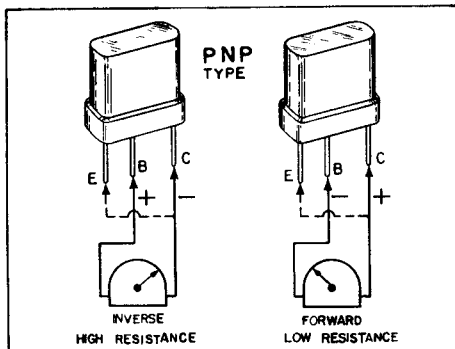

FIGURE 2 - PNP TYPE

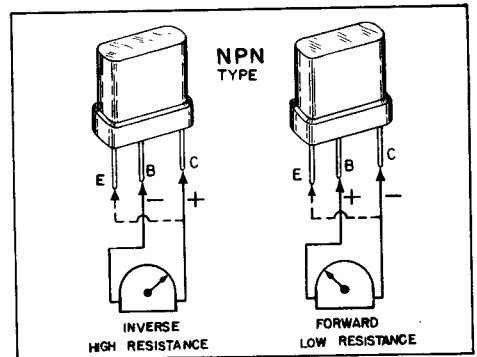
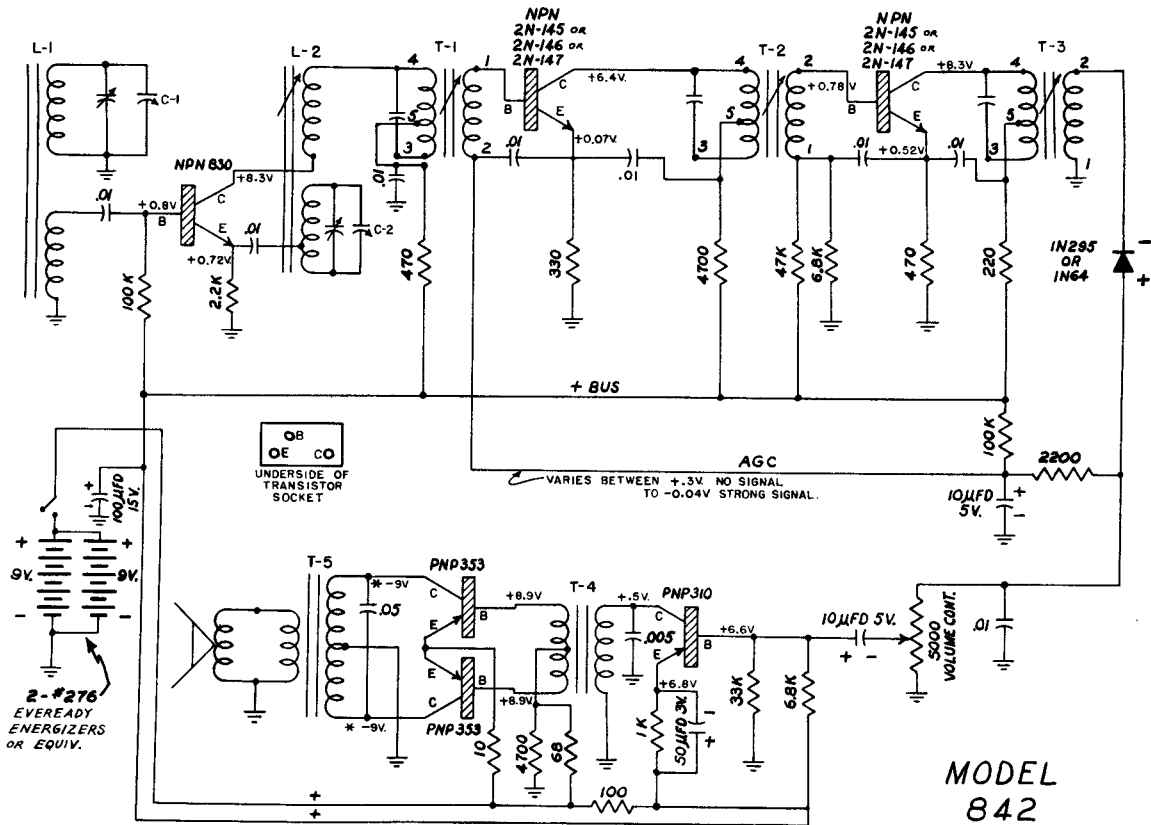

FIGURE 3 - NPN TYPE

EMERSON RADIO Model 842, (Portable Transistor Radio



MODEL 842

*INDICATES GROUND LEAD OF V.T.V.M. CONNECTED TO B+ SIDE OF ENERGIZER

(See material on preceding page on testing transistors)

CONDITIONS FOR VOLTAGE READINGS

1. Voltages indicated are positive unless otherwise indicated.
2. Measurements made with voltohmmyst or equivalent.
3. All measurements taken from pin to chassis unless otherwise indicated.

ALIGNMENT INSTRUCTIONS

Volume control should be at maximum; output of signal generator should be no higher than necessary to obtain an output reading. Use an insulated alignment screwdriver for adjusting.

	DUMMY ANTENNA	SIGNAL GENERATOR COUPLING	SIGNAL GENERATOR FREQUENCY	RADIO DIAL SETTING	OUTPUT METER	ADJUST	REMARKS
1	.1 mfd.	High side to orange lead of bar loop antenna. Low side to chassis.	455 KC.	Tuning condenser fully open.	Across voice coil	T2, T3 and T1	Adjust for maximum output starting with T3.
2		Use a loop set perpendicular and about 20" from center of bar loop ant. in set.	1650 KC.	Tuning condenser fully open.	Across voice coil	C-2 (osc. trimmer)	Fashion loop of several turns of wire and radiate signal into bar loop of receiver. Adjust for maximum output.
3		"	1400 KC.	Tune for maximum output.	Across voice coil.	C-1 (Ant. trimmer)	Adjust for maximum output.
4		"	600 KC.	Tuning condenser set for 600 KC.	Across voice coil.	Osc. slug in L-2	Rock the variable cond. each side of 600 KC while adj. osc. slug for maximum response.
5		"	1650 KC.	Tuning condenser fully open.	"	C-2 Osc. trimmer	If readjustment is necessary repeat steps 2 to 4 until no further improvement is noted.

EMERSON RADIO

Model 843, Chassis 120298

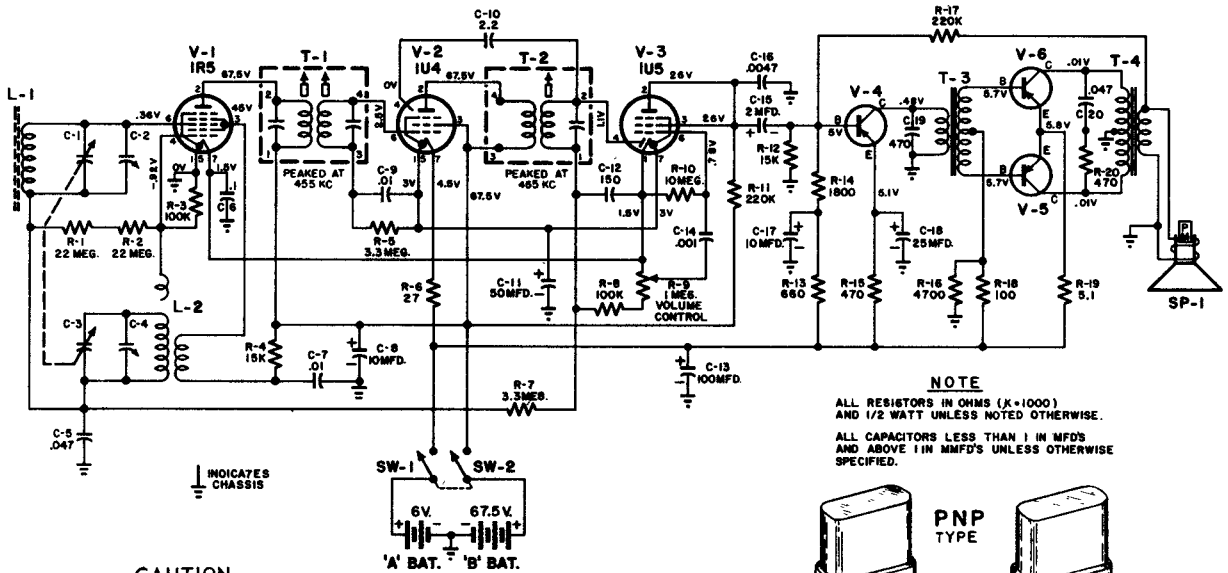

CAUTION

Use only a vacuum tube type of ohmmeter. The R x 10 scale must be used for all forward (low) resistance measurements. Do not use the R x 1 scale as this might damage the transistor. A shunt type ohmmeter should not be used. If in doubt as to the type of vacuum tube ohmmeter you have, place a 1,000 ohm resistor in series with it and subtract this 1,000 ohms from the reading obtained.

If these instructions are not followed, damage to the transistors may result since some non-electronic type of ohmmeters use high internal battery voltages.

CONDITIONS FOR TAKING VOLTAGE READINGS

- Voltages indicated are positive d.c., resistance is ohms, unless otherwise noted.
- Measurements made with voltohmmyst or equivalent.
- All measurements taken between points and chassis, unless otherwise indicated.
- Before taking resistance measurements, turn on-off switch to the "off" position (or disconnect batteries).
- Then remove transistors.
- Volume control at maximum, no signal applied for voltage measurements.
- Nominal tolerance in component values makes possible a variation of $\pm 15\%$ in readings.
- K is Kilohms, MEG in megohms.

ALIGNMENT INSTRUCTIONS

Volume control should be at maximum; output of signal generator should be no higher than necessary to obtain an output reading. Use an insulated alignment screwdriver for adjusting.

	DUMMY ANTENNA	SIGNAL GENERATOR COUPLING	SIGNAL GENERATOR FREQUENCY	RADIO DIAL SETTING	OUTPUT METER	ADJUST	REMARKS
1	.1 mfd.	High side to orange lead of bar loop antenna. Low side to chassis.	455 KC.	Tuning condenser fully open.	Across voice coil	T2, T3 and T1	Adjust for maximum output starting with T3.
2		Use a loop set perpendicular and about 20" from center of bar loop ant. in set.	1620 KC.	Tuning condenser fully open.	Across voice coil	C-2 (osc. trimmer)	Fashion loop of several turns of wire and radiate signal into bar loop of receiver. Adjust for maximum output.
3		"	1400 KC.	Tune for maximum output.	Across voice coil.	C-1 (Ant. trimmer)	Adjust for maximum output.
4		"	600 KC.	Tuning condenser set for 600 KC.	Across voice coil.	Osc. slug in L-2	Rock the variable cond. each side of 600 KC while adj. osc. slug for max. response.
5		"	1620 KC.	Tuning condenser fully open.	"	C-2 Osc. trimmer.	If readjustment is necessary repeat steps 2 to 4 until no further improvement is noted.

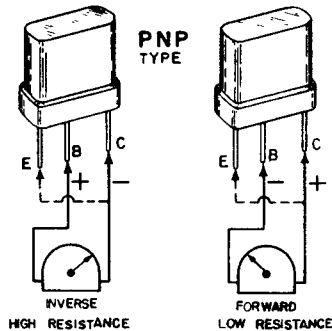



CORONADO "PAL" RADIO MODEL RA33-8115A

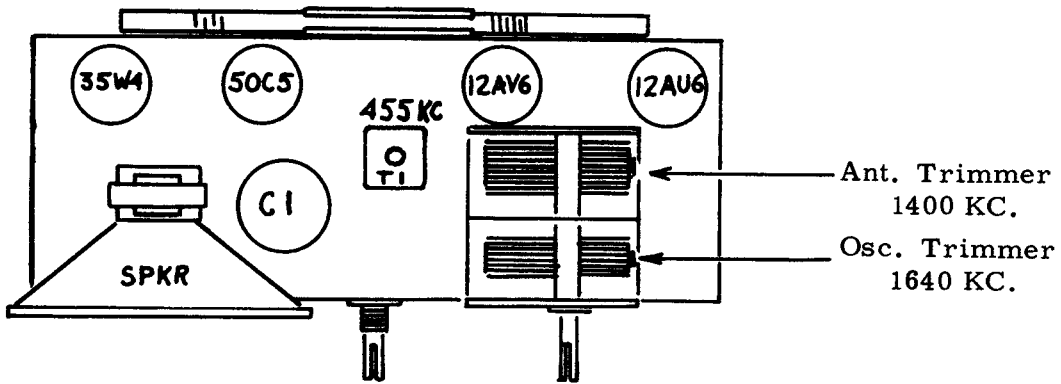
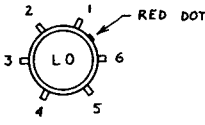
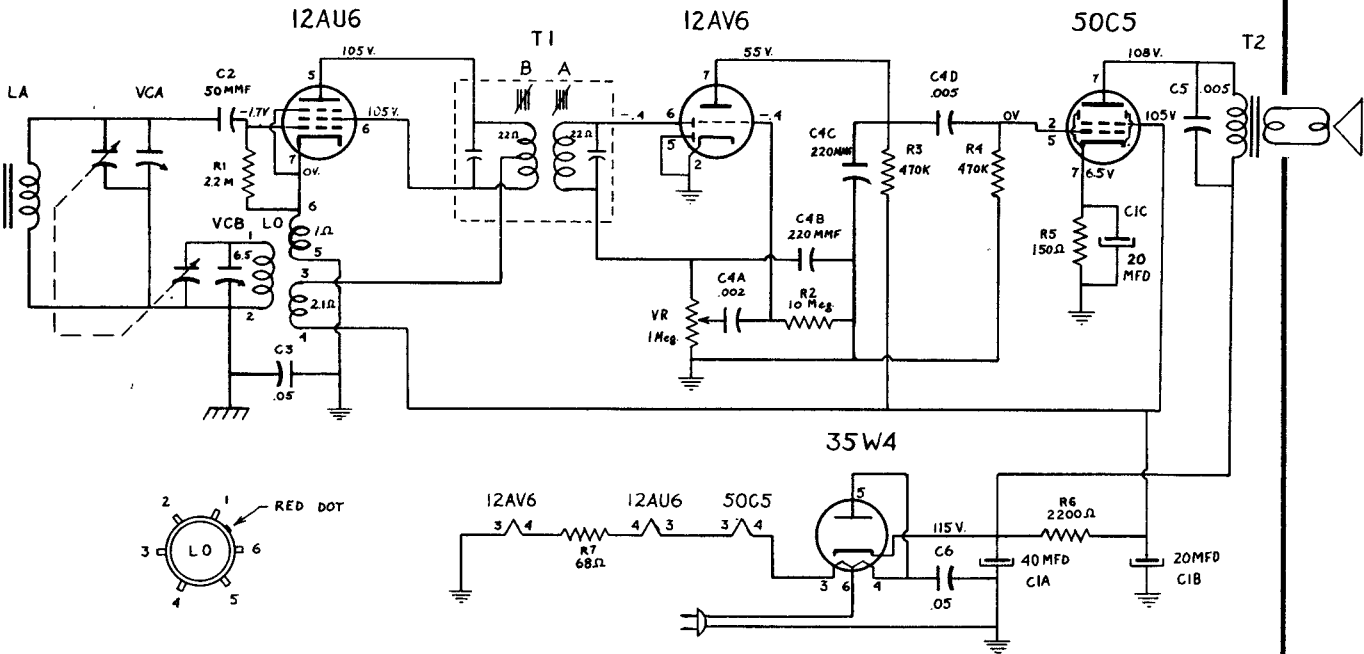

Chassis Top View

ALIGNMENT INSTRUCTIONS

Adjust all trimmers for maximum output. Repeat the procedure given below as final check.
CAUTION: This is an AC-DC receiver, and when aligning the set it is necessary to isolate the signal generator or the receiver from the line by the use of an isolation transformer, or to place a .2MFD condenser in each test lead of the signal generator.

Frequency	Dummy Antenna	Connection to set	POSITION OF VARIABLE	ADJUST FOR MAXIMUM	NOTES
455 KC	.05 MFD	Stator of VCA	Two-thirds open	T1 A & B	Attenuate gen. for about .4 volt across voice coil. Keep gen. low
1640 KC	.05 MFD	Stator of VCA	Fully open	VCB	
1400 KC	Radiate signal into set with a loop of several turns	Tune in sig. generator		VCA	

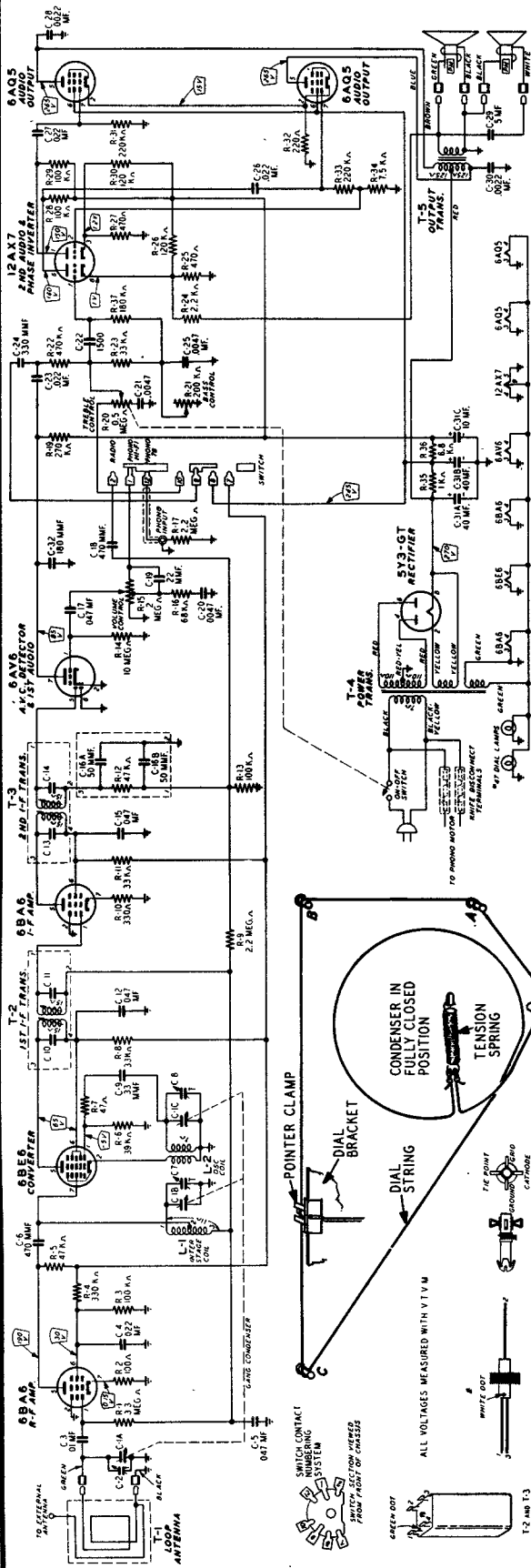

CORONADO RADIO MODELS
RAI-9245B (MAH.)
RAI-9246B (OAK)

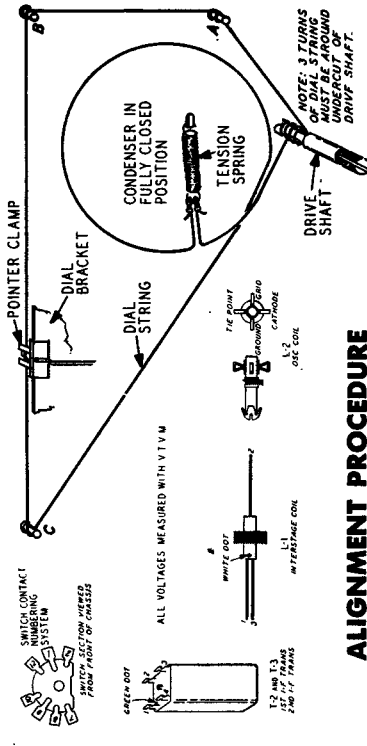
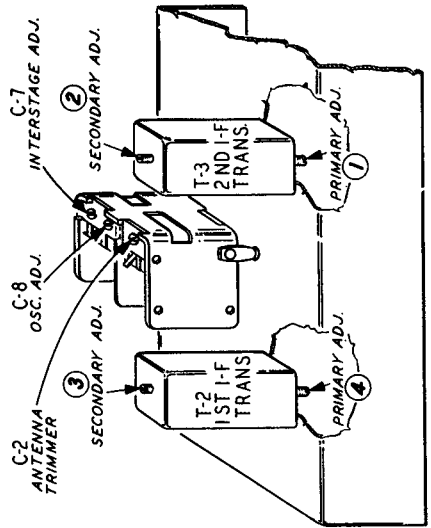

ALIGNMENT PROCEDURE

The following is required for aligning:
 An All Wave Signal Generator Which Will Provide an Accurately Calibrated Signal at the Test Frequencies as Listed.
 Output Indicating Meter, Non-Metallic Screwdriver, Dummy Antennas — .1 mf, and 50 mmf.

Volume Control Maximum all Adjustments.
 Connect Chassis to Ground Post of Signal Generator with a Short Heavy Lead.
 Allow Chassis and Signal Generator to "Heat Up" for Several Minutes.

FREQUENCY SETTING	SIGNAL GENERATOR		CONNECT GENERATOR OUTPUT TO	CONNECT DUMMY ANTENNA TO	GANG CONDENSER SETTING	ADJUST	ADJUST FOR
	Control Grid	Control Grid					
455 KC	Control Grid I-F 68A6 Pin No. 1	Control Grid 68E6 Pin No. 1	Chassis Base	.1 mf	Rotor Fully Open	2nd I.F. Pri. (1) and Sec. (2)	Maximum Output
455 KC	Control Grid 68E6 Pin No. 7	Control Grid 68E6 Pin No. 7	Chassis Base	.1 mf	Rotor Fully Open	1st I.F. Pri. (4) and Sec. (3)	Maximum Output
1620 KC	R-F 68A6 Pin No. 1	Control Grid 68E6 Pin No. 1	Chassis Base	.1 mf	Rotor Fully Open	2nd I.F. Pri. (1) and Sec. (2)	Maximum Output
1400 KC	Control Grid 68E6 Pin No. 1	Control Grid 68E6 Pin No. 1	Chassis Base	.1 mf	Turn Rotor to Max. Output. Set Pointer to 1400 KC See Note A	Oscillator C-8	Maximum Output
1400 KC	External Antenna Terminal	External Antenna Terminal	Chassis Base	50 mmf	Turn Rotor to Max. Output. Set Pointer to 1400 KC See Note A	Interstage C-7 See Note B	Maximum Output
						Antenna C-2 See Note B	Maximum Output

NOTE A—If the pointer is not at 1400 KC on the dial, reset pointer to the 1400 KC mark on the dial scale.
 NOTE B—Turn the rotor back and forth and adjust the trimmer until the peak of greatest intensity is obtained.

GENERAL ELECTRIC

MODEL 453

Model 895 circuit is the same as 453 with addition of clock and switch arrangement.

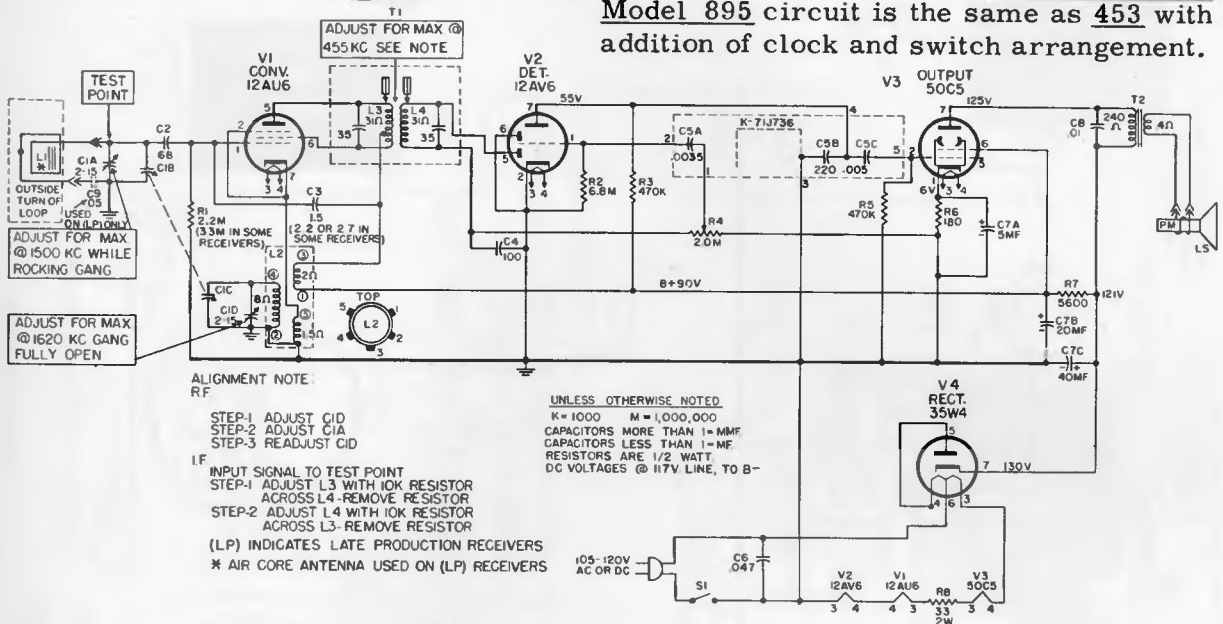

TO REMOVE CHASSIS FROM CABINET

Remove cabinet back and interlock. Remove the five self-tapping screws (hex heads), one on each corner of the chassis, and the single hex-head screw just below the tuning gang capacitor. Pull off the volume control knob. The tuning control knob is captivated to the cabinet, so the chassis must be pulled out of the cabinet, at the same time pulling it off the tuning knob which remains on the cabinet. When pulling out the chassis, first close the tuning capacitor, grasp the capacitor with the thumb and forefinger of one hand and the tuning knob with the other hand and pull. **CAUTION:** It is important to use extreme care while replacing parts and/or soldering on this chassis, as too much heat on the chassis will cause the copper plating to become unbonded. Only apply the soldering iron long enough to melt the solder and pull out the part to be replaced.

TO REPLACE A TUBE SOCKET

Cut the socket free by cutting all of the socket terminals at the chassis. Now, heat each terminal only enough so that the socket may be pushed out. The new socket can now be inserted into the holes left by the old one and soldered into place.

TO REPLACE THE VOLUME CONTROL

Remove the shaft nut, then cut the center and lower terminals. Apply only enough heat to the upper terminal to pull out the control. Apply heat to the center and lower terminals, so they may be pushed out. The new control may now be inserted into place and soldered.

NOTE: The shield can on T1 may be removed by unfastening the spring clip and lifting the can off the transformer, thereby leaving the coils open for inspection or repair.

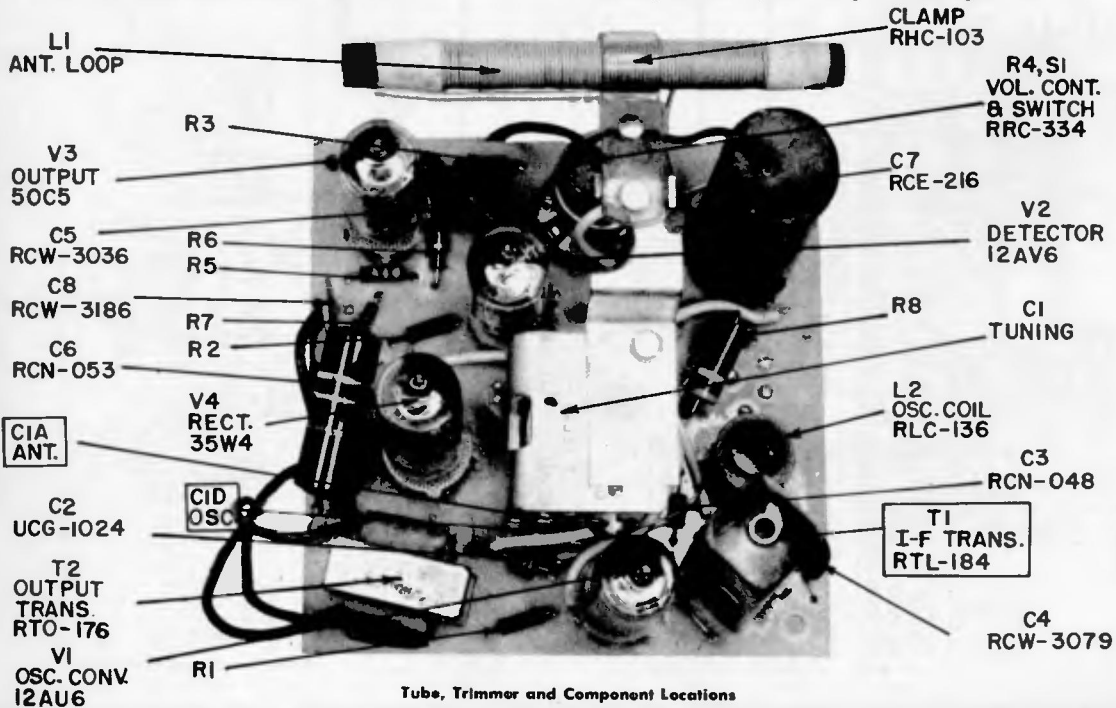

Tube, Trimmer and Component Locations

GENERAL ELECTRIC

MODELS
465
466
467

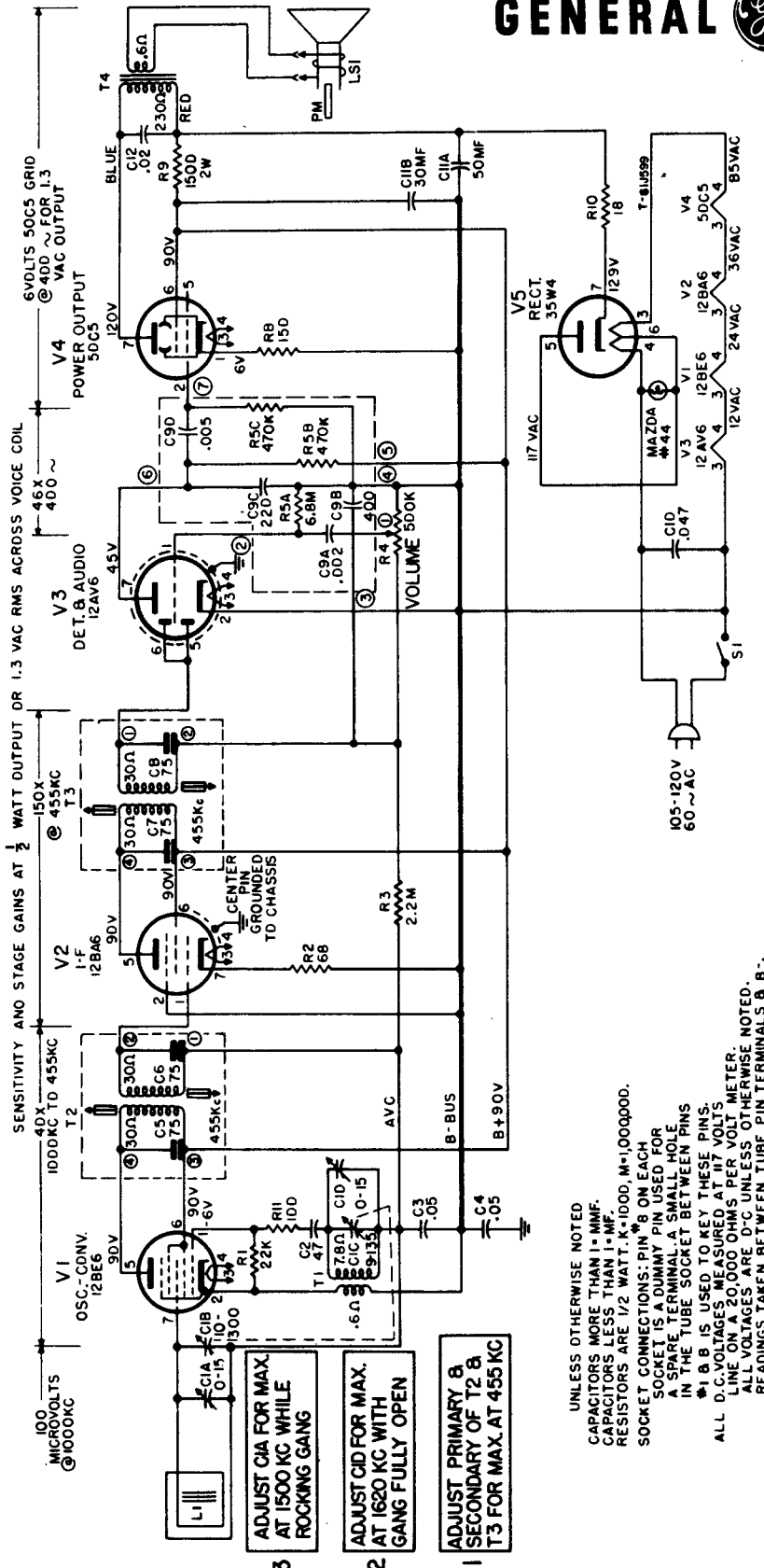

SCHEMATIC DIAGRAM

TUBE AND TRIMMER LOCATION

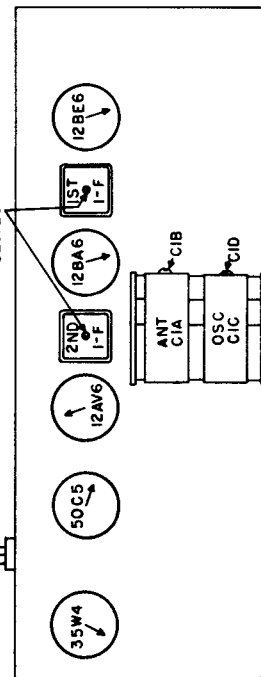

TUBE AND TRIMMER LOCATION

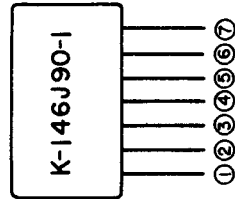

COUPLING NETWORK
(RCW-3207)

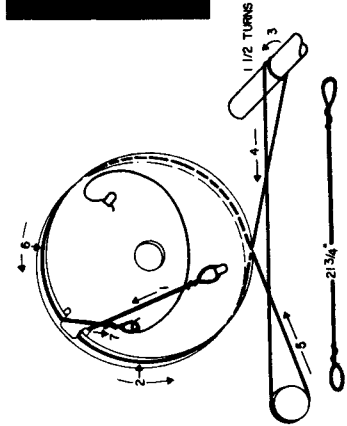

DIAL CORDING

UNLESS OTHERWISE NOTED
CAPACITORS MORE THAN 1 μ MMF.
RESISTORS ARE 1/2 WATT. K=1000, M=1,000,000.
SOCKET CONNECTIONS: PIN #8 ON EACH
SOCKET IS A DUMMY PIN USED FOR
A SPARE TERMINAL. A SMALL HOLE
IN THE TUBE SOCKET BETWEEN PINS
#1 & #8 IS USED TO KEY THESE PINS.
ALL D.C. VOLTAGES MEASURED AT 117 VOLTS
LINE ON A 20,000 OHMS PER VOLT METER.
ALL VOLTAGES ARE D-C UNLESS OTHERWISE NOTED.
READINGS TAKEN BETWEEN TUBE PIN TERMINALS & B⁺.

- 3 ADJUST CIA FOR MAX. AT 1500 KC WHILE ROCKING GANG
- 2 ADJUST CID FOR MAX. AT 1620 KC WITH GANG FULLY OPEN
- 1 ADJUST PRIMARY & SECONDARY OF T2 & T3 FOR MAX. AT 455 KC

GENERAL ELECTRIC

MODELS
470
471
472

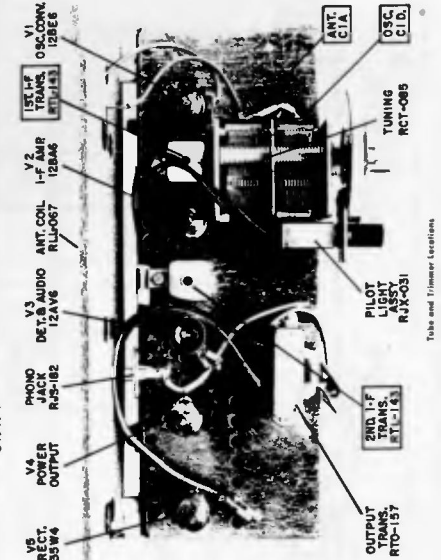
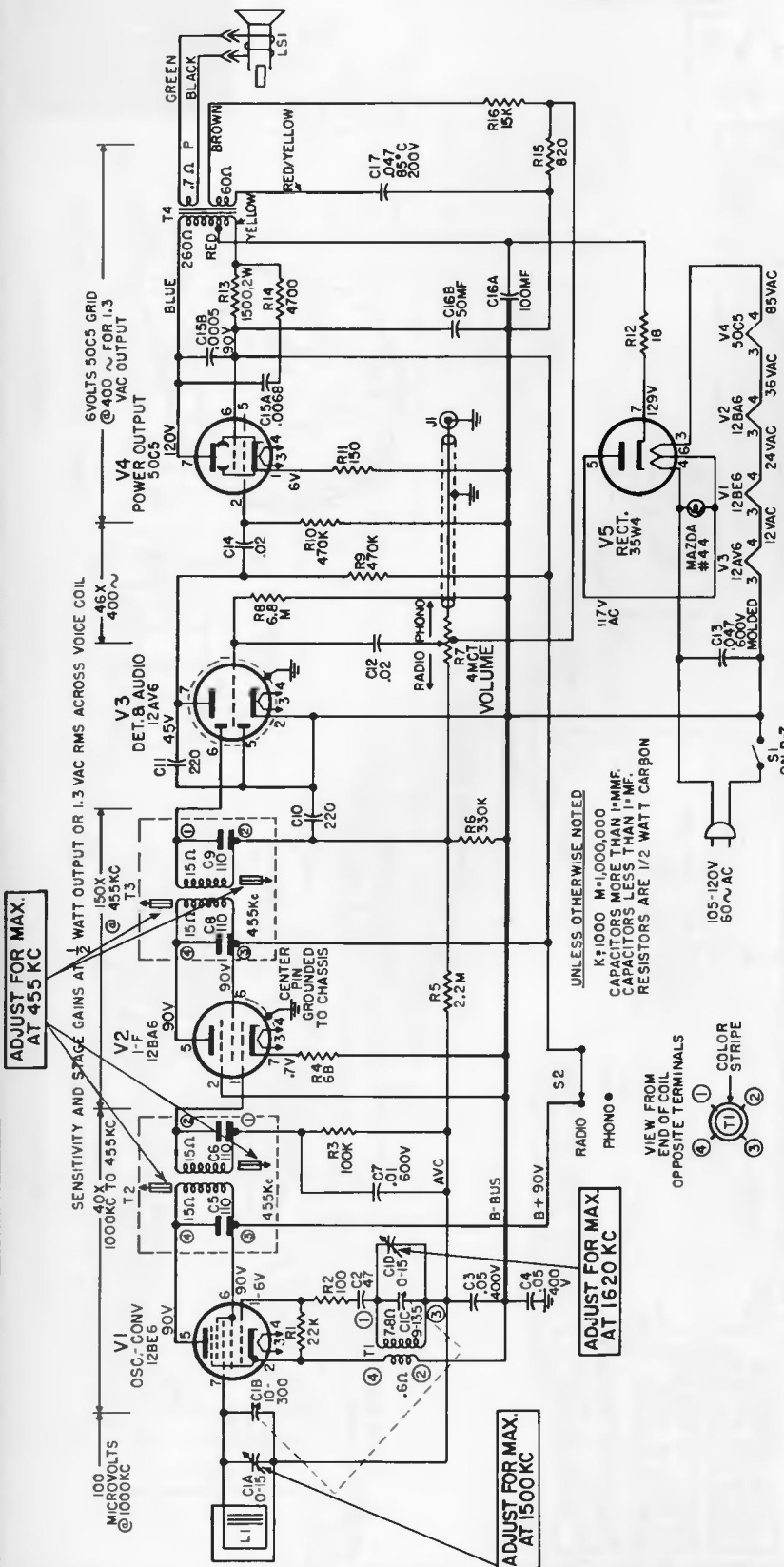

Tube and Trimmer Locations

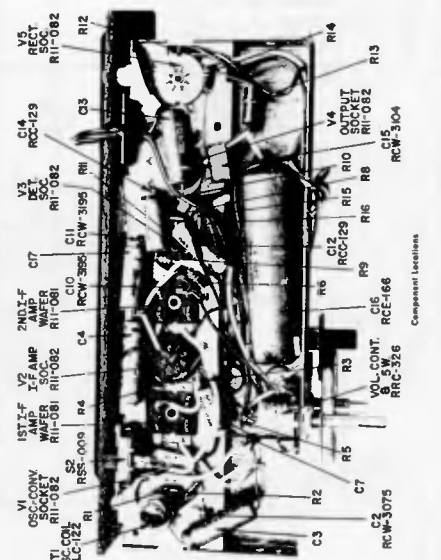

Component Locations

GENERAL ELECTRIC

MODELS

475

476

477

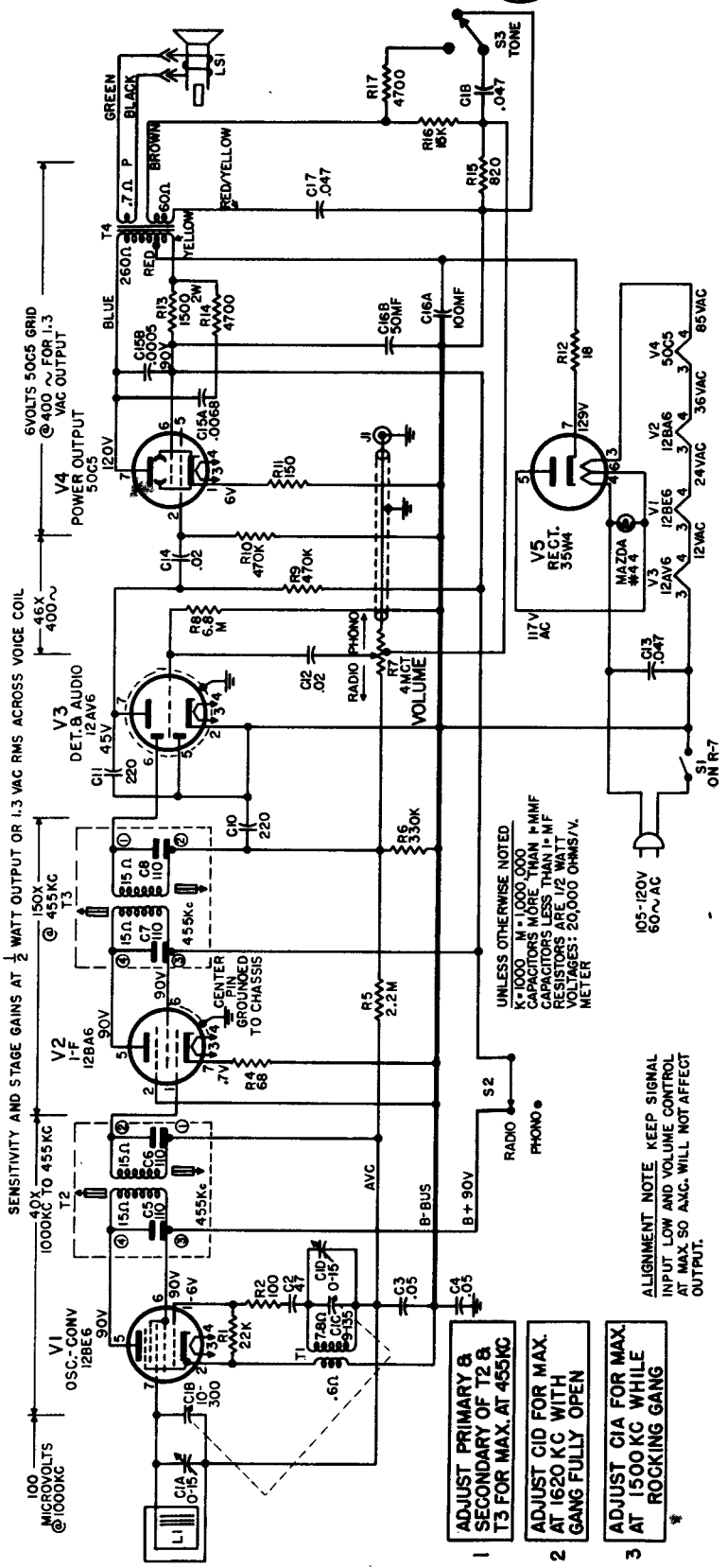

Schematic Diagram

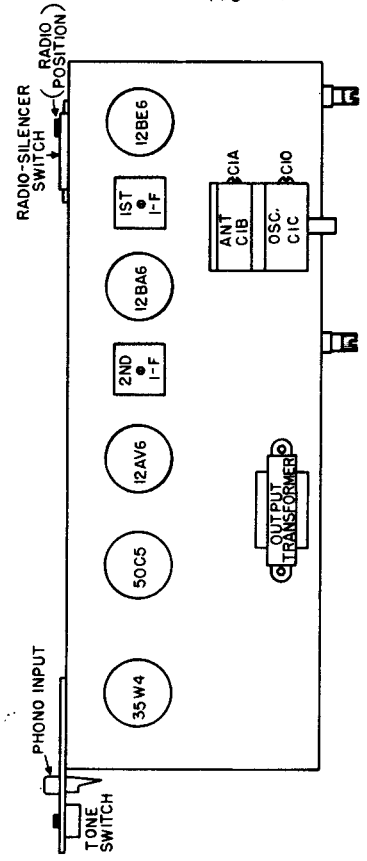
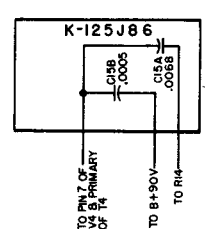
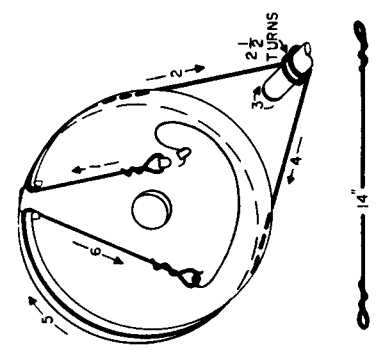

GENERAL ELECTRIC

MODEL
480

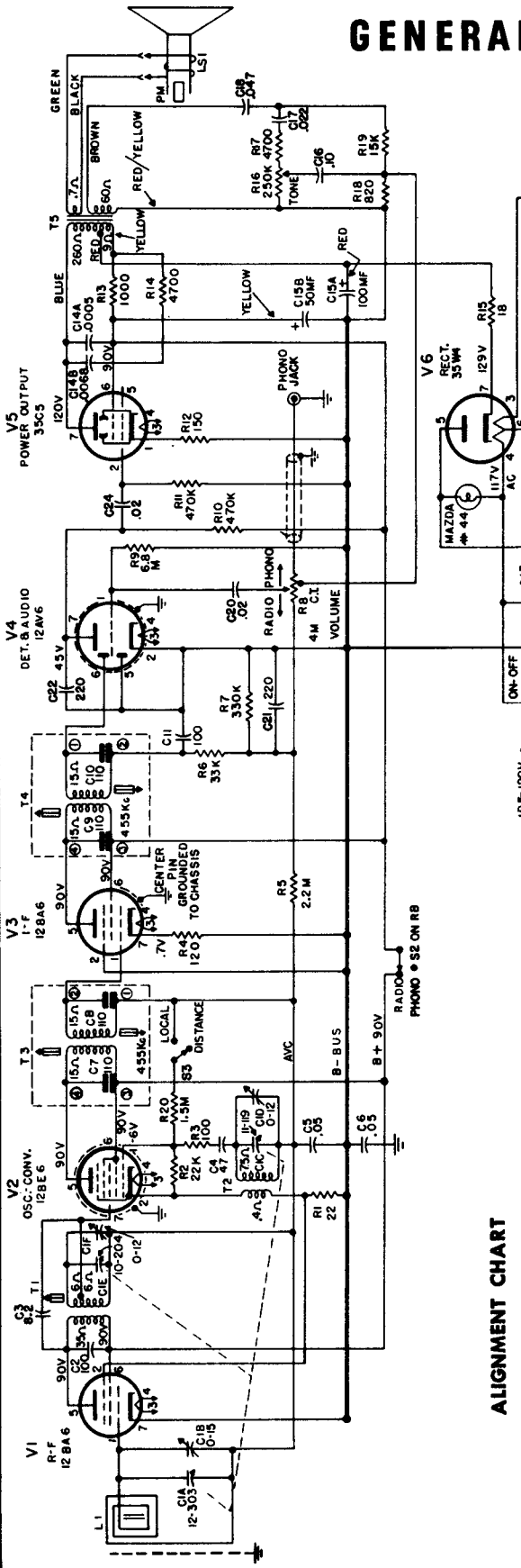

ALIGNMENT CHART

STEP	CONNECT TEST OSCIL-LATOR TO	TEST OSCIL-LATOR SETTING	RECEIVER TUNING	ADJUST FOR MAXIMUM OUTPUT
1	12BA6, V3 grid (pin 1) in series with .05 mf.			Cores of 2nd i-f trans. T4
2	12BE6, V2 grid (pin 7) in series with .05 mf.	455 KC	Minimum capacity	Cores of 1st i-f trans-former T3
3				Recheck adjustment of T4 and T3
4	Inductively coupled to radio loop L1	1620 KC	Minimum capacity	C1D, oscillator trimmer
5		1500 KC	For maximum	C1F, r-f trimmer
6				C1B, antenna trimmer
7		Approximately 600 KC	For maximum	Core of r-f transformer T1. Rock in with receiver tuning
8	Repeat steps 4, 5, 6 and 7.			

UNLESS OTHERWISE NOTED
VOLTAGES MEASURED WITH 200000 OHMS
IMPEDANCE METER AT 117V
LINE-NO SIGNAL
RESISTORS IN OHMS - K1000, M = 1,000,000
CAPACITORS (LESS THAN ONE - MF
RESISTORS ARE 1/2 WATT

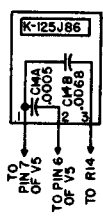

C14—Wiring

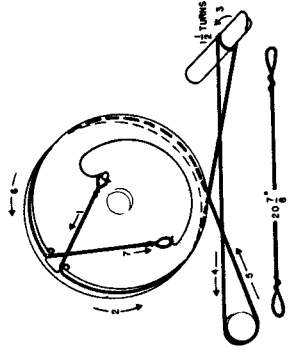

Dial Cord Springing

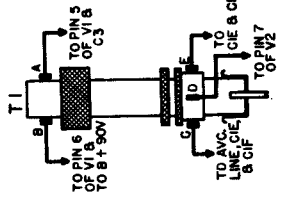

R-F Coil Wiring

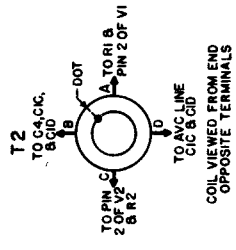

Osc. Coil Wiring

GENERAL ELECTRIC

MODELS
665
666
667

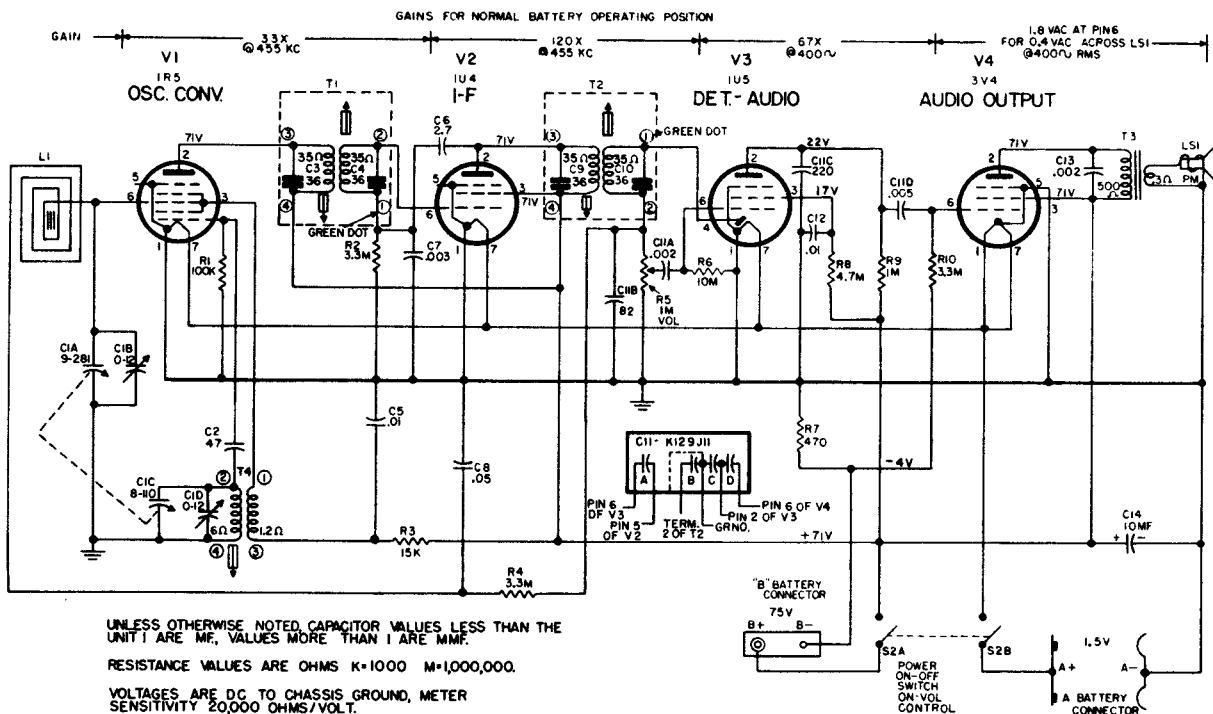

CHASSIS REMOVAL:

1. Remove the two control knobs.
2. Remove the four hex head screws in cabinet bosses.
3. Remove complete chassis.

BATTERY INSTALLATION:

The back of the radio is removed by inserting and twisting a coin in the slots provided at the top just under the handle. Place the batteries in the same position as shown in the rear view illustration, making sure the "B" battery connections are well seated. The "A" battery contacts are automatically made when the batteries are slipped into position. The two "A" batteries will wear out together; therefore, always replace both "A" batteries at the same time.

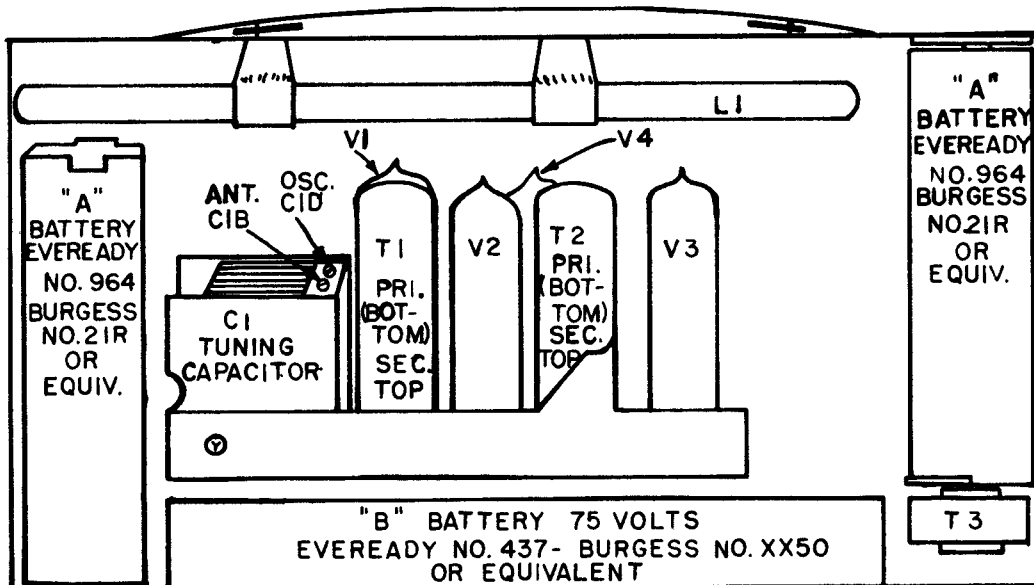

GENERAL ELECTRIC

MODELS

670
671
672
673

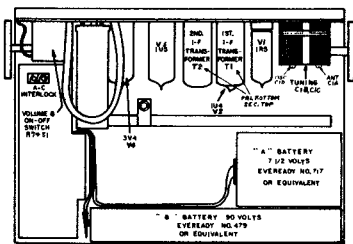
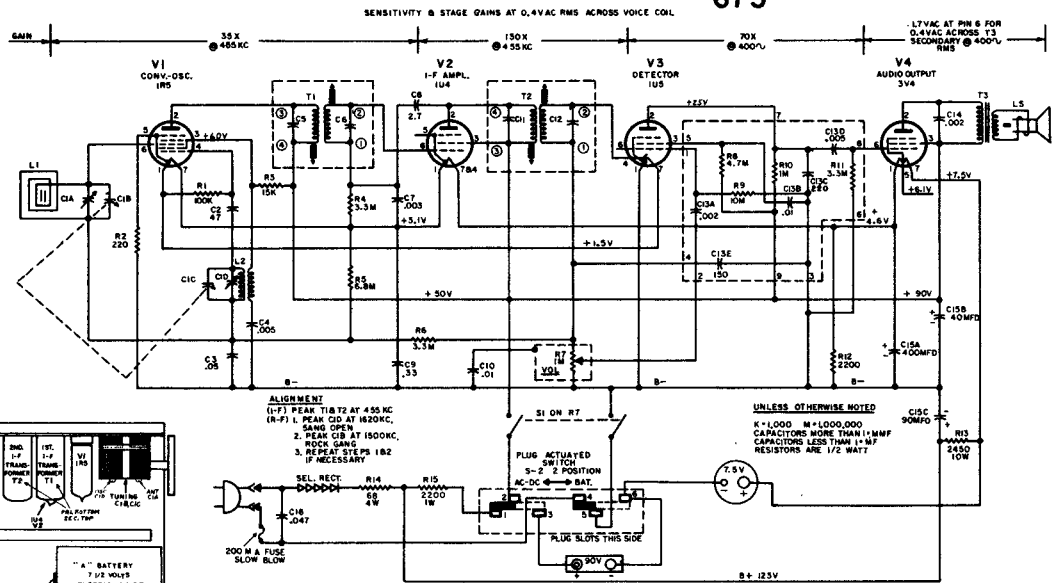

GENERAL INFORMATION

The Models 670, 671, 672 and 673 are four-tube superhetrodyne portable radio receivers, which operate either on self-contained batteries or from a power line source of 105 to 120 volts A-C or D.C.

These models are very compactly made and incorporate two plated circuit chassis; the smaller of which contains the power supply components. The front of the cabinet swings down and open, providing easy accessibility to tubes and batteries.

CHASSIS REMOVAL:

The chassis is easily removed by means of the following procedure.

1. Swing down cabinet front by grasping front at top edge under handle.

2. Remove tuning and volume control knobs by pulling straight off their shafts.

3. Remove the two small Phillips-head screws from the top rear edge of the metal chassis mounting bracket.

4. Slide chassis and bracket out of cabinet.

5. Remove bracket from chassis by removing the 1/4" mounting screw from the bracket.

The power supply chassis is removed from the cabinet by removing the four small hex-head mounting screws.

The speaker is mounted on the cabinet front and may be removed by removing the four speaker mounting clips which secure the speaker to the four bosses on the inside of the cabinet front.

IMPORTANT: Care should be taken when replacing defective parts, to apply as little heat to terminals and connections as possible; as excessive heat will damage the plated wiring on the chassis boards.

VOLUME CONTROL REPLACEMENT:

The volume control, on-off switch, and control mounting bracket, are a combined assembly (Catalog No. RRC-367) and must be replaced as such.

The chassis must first be removed from the cabinet as described under CHASSIS REMOVAL and the control removed as follows:

1. Cut off the three control lugs and the four switch lugs.

2. Apply enough heat to the bracket mounting lugs at one end of the bracket to allow that end to be pulled free of the board.

3. Follow the same procedure with the two lugs at opposite end of bracket and remove the assembly.

4. Heat each lug remaining in the board only enough to push it out.

5. The new assembly can now be inserted into the holes left by the old one and soldered into place.

TO REPLACE A TUBE SOCKET:

Cut the socket free by cutting all of the socket terminals at the chassis. One socket (V2) has a center terminal which must be unsoldered. Now, heat the pieces of terminals remaining in the board only enough so they may be pushed out. The new socket can now be inserted into the holes left by the old one and soldered into place.

BATTERY INSTALLATION:

Place batteries in place as shown in the Tube and Battery location illustration. Make sure the battery connections are well seated.

GENERAL ELECTRIC

MODELS
675
676

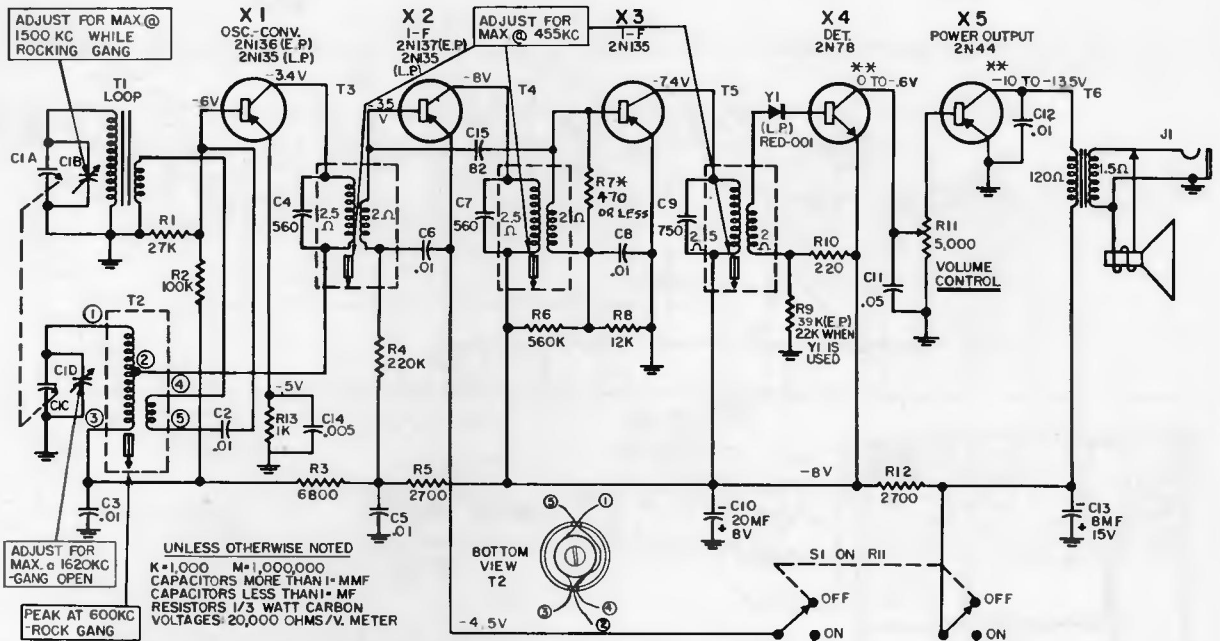

ADJUST FOR MAX @ 1500 KC WHILE ROCKING GANG

ADJUST FOR MAX @ 455KC

ADJUST FOR MAX @ 1620KC GANG OPEN

PEAK AT 600KC ROCK GANG

UNLESS OTHERWISE NOTED
K=1,000 M=1,000,000
CAPACITORS MORE THAN 1-MF
CAPACITORS LESS THAN 1-MF
RESISTORS 1/3 WATT CARBON
VOLTAGES: 20,000 OHMS/V. METER

* NOTE:
REPLACEMENT OF X1, X2 OR X3
MAY REQUIRE CHANGING THE
VALUE OF R7 **TRY 470 OR LESS** BATTERY PLUG
VOLTAGES MEASURED TO GND. TOP VIEW
WITH 20,000 OHM/VOLT METER -
NORMAL SIGNAL APPLIED.

** VOLTAGE VARIES WITH SETTING
OF R11.

E.P. INDICATES EARLY PRODUCTION RECEIVERS
L.P. INDICATES LATE PRODUCTION RECEIVERS

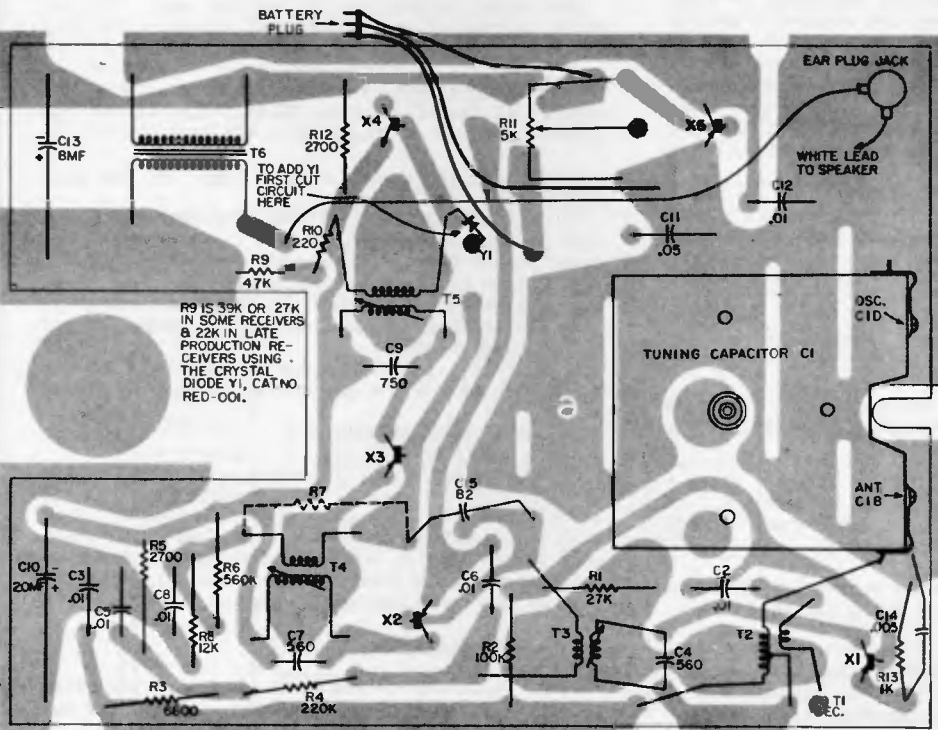
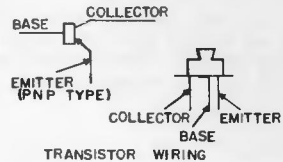

COMPONENT WIRING & TRANSISTOR LOCATIONS

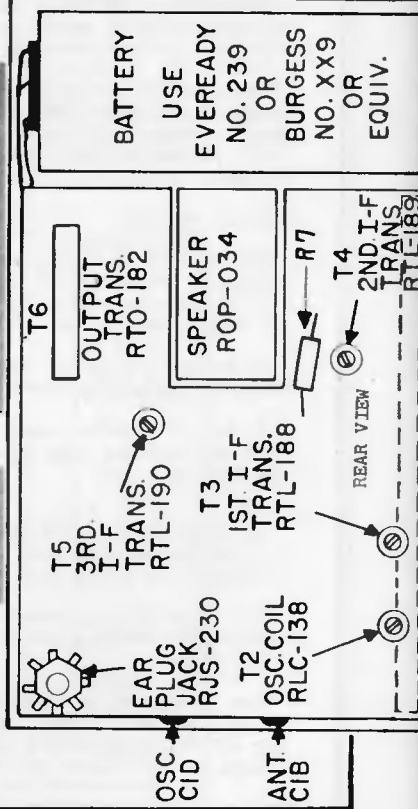

BATTERY
USE
EVEREADY
NO. 239
OR
BURGESS
NO. XX9
OR
EQUIV.

GENERAL ELECTRIC

CLOCK-RADIO
MODELS

90Q
902
903

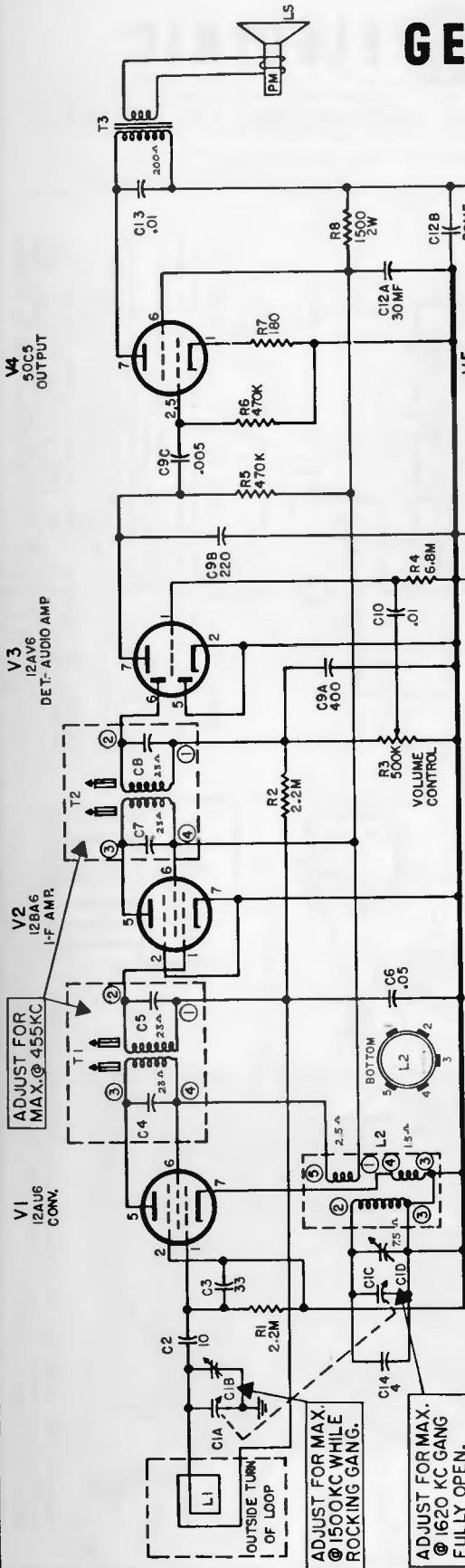
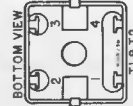

UNLESS OTHERWISE NOTED
CAPACITORS MORE THAN 1 μMMF
CAPACITORS LESS THAN 1 μMMF
RESISTORS ARE 1/2 WAT, 10%
K=1000 M=1000,000
DC VOLTAGES @ 117V LINE TO B-
WITH 20,000 Ω/VOLT METER

Schematic Diagram
Models 900, 902, 903

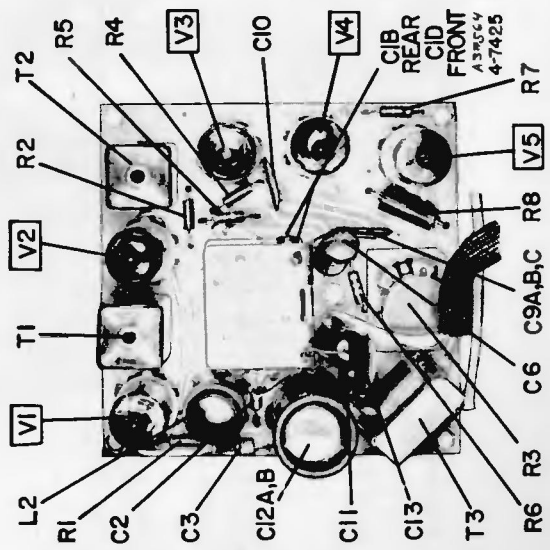

CAUTION: When soldering use only a small soldering iron (35 watts maximum). Too much heat on the plated wiring may cause it to become unbonded.

NOTE: The tuning knob on this receiver is captivated to the cabinet and cannot be removed unless the chassis is removed.

TO REMOVE THE CHASSIS: Remove the volume control knob and the cabinet back. With a 1/4" nut driver remove the five self-tapping screws holding the chassis to the cabinet (one on each corner and one directly under the tuning capacitor). The chassis may now be grasped by the tuning capacitor in one hand and pulled off the tuning knob. The tuning knob may now be removed by pulling off the clip (RMS-356) on its shank.

ADJUST FOR MAX. @ 455 KC

ADJUST FOR MAX. @ 1500 KC WHILE ROCKING GANG.

ADJUST FOR MAX. @ 1620 KC GANG FULLY OPEN.

GENERAL ELECTRIC

Models 900D, 902D, 903D, 905, 906, 907, 915, and 916

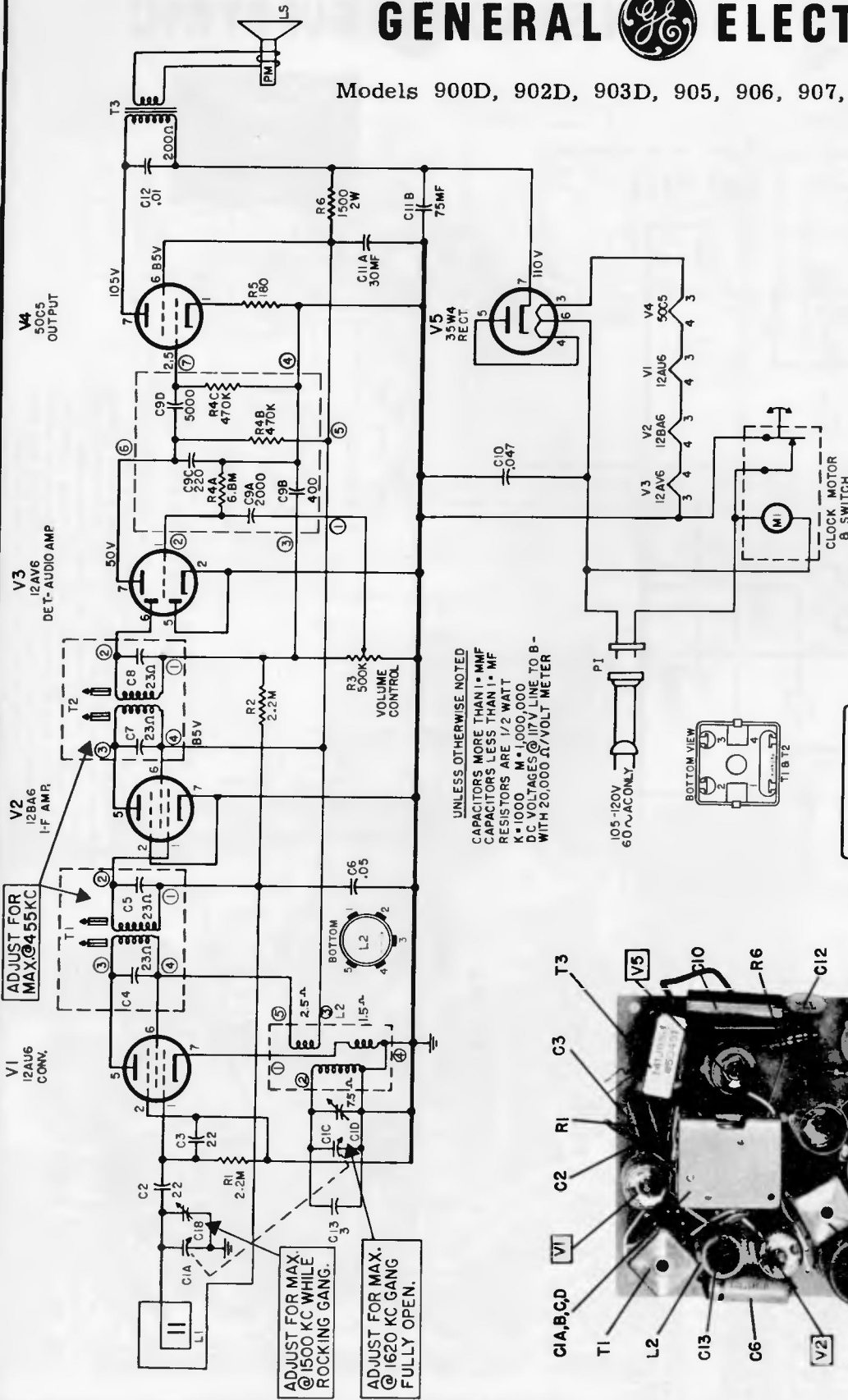

UNLESS OTHERWISE NOTED
CAPACITORS MORE THAN 1" MMF
CAPACITORS LESS THAN 1" MF
RESISTORS ARE 1/2 WATT
K=1000 M=1,000,000
DC VOLTAGES @ 117V LINE TO B-
WITH 20,000 Ω/VOLT METER

TO REMOVE CABINET FRONT: Unscrew the four screws on the bottom of the cabinet. The front panel, including the clock and chassis, may now be pulled from the back. Because of the power cord interlock behind the clock, this side will require a little more effort than the radio side.

NOTE: The tuning knob on these receivers is captivated on the cabinet. It is necessary to remove the chassis from the cabinet before the tuning knob may be taken off the cabinet.

TO REMOVE THE CHASSIS: Remove the cabinet front and pull off volume knob. With a 1/4" nut driver, remove the five self tapping screws holding the chassis to the cabinet front. The chassis may now be removed from the cabinet front by pulling it off of the tuning knob.

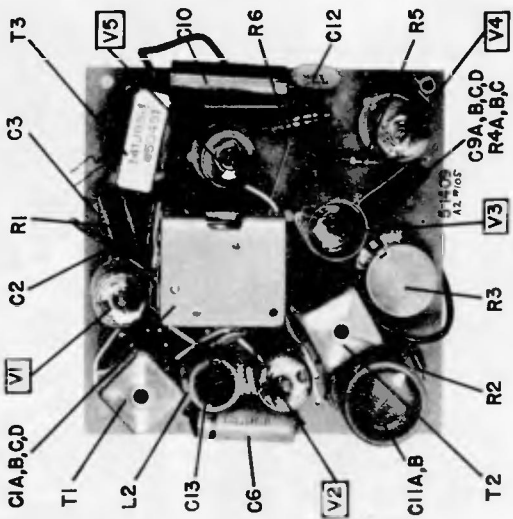
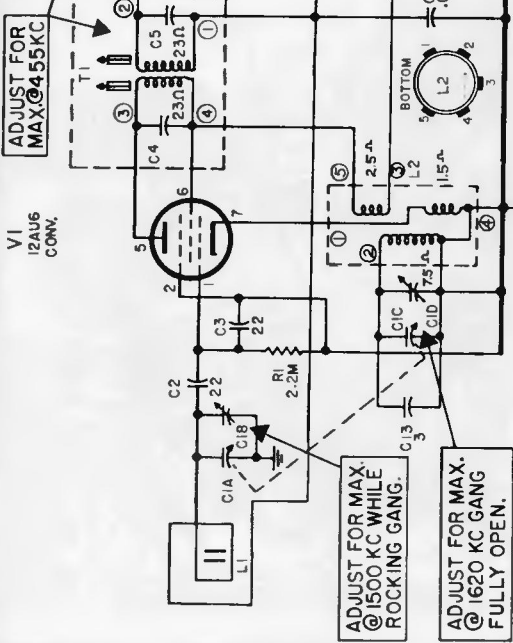

CAUTION: When soldering, use only a small soldering iron (35 to 50 watts maximum). Too much heat on the plated wiring may cause it to become unbonded.

GENERAL ELECTRIC ELECTRIC

**CLOCK-RADIO
MODELS**

911 & 911H

912

913

The Models 911, 912 and 913 radios all utilize the same chassis, their differences being only in the cabinet and appearance item colors. The chassis incorporates four tubes plus one rectifier in a superheterodyne circuit. An electric alarm clock provides automatic on-off control of this receiver as well as the 1100-watt appliance receptacle located on the rear of the radio.

Always use an isolation transformer when servicing or aligning this receiver to protect the test equipment being used.

When aligning, keep the signal input low so the AVC will not affect the output. Alignment information is included with the schematic diagram.

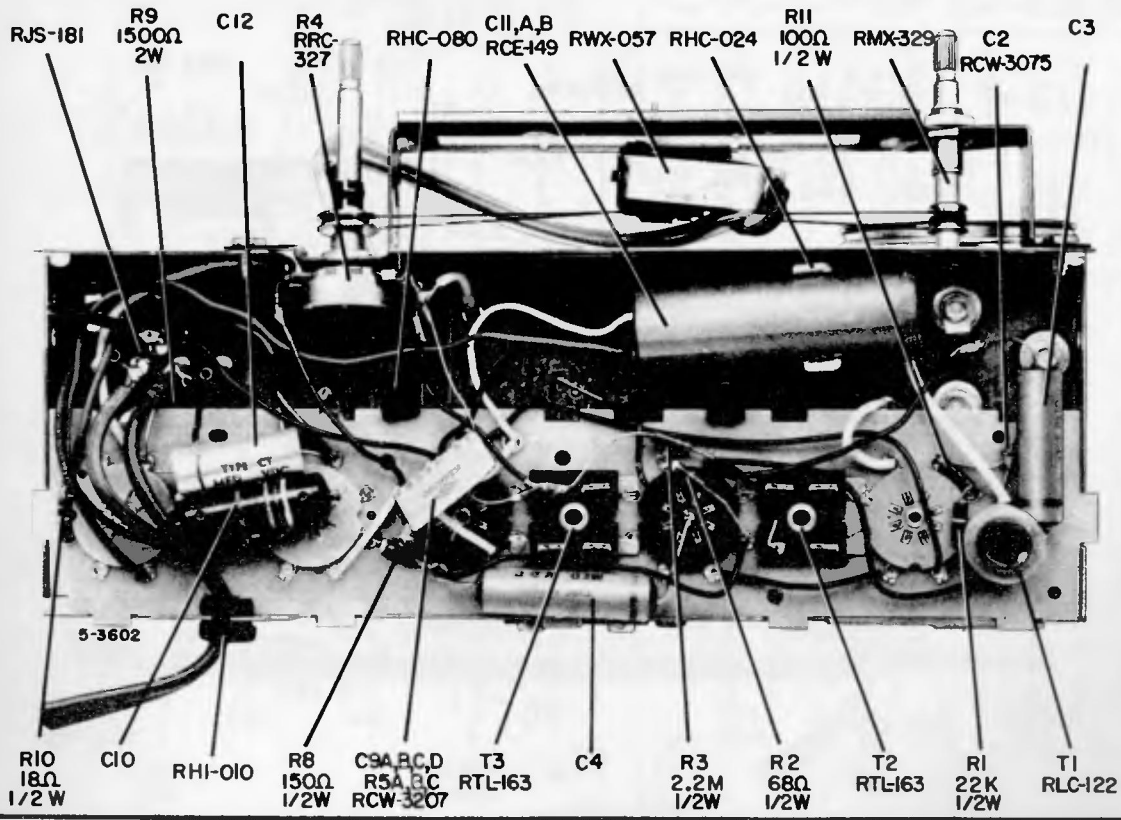
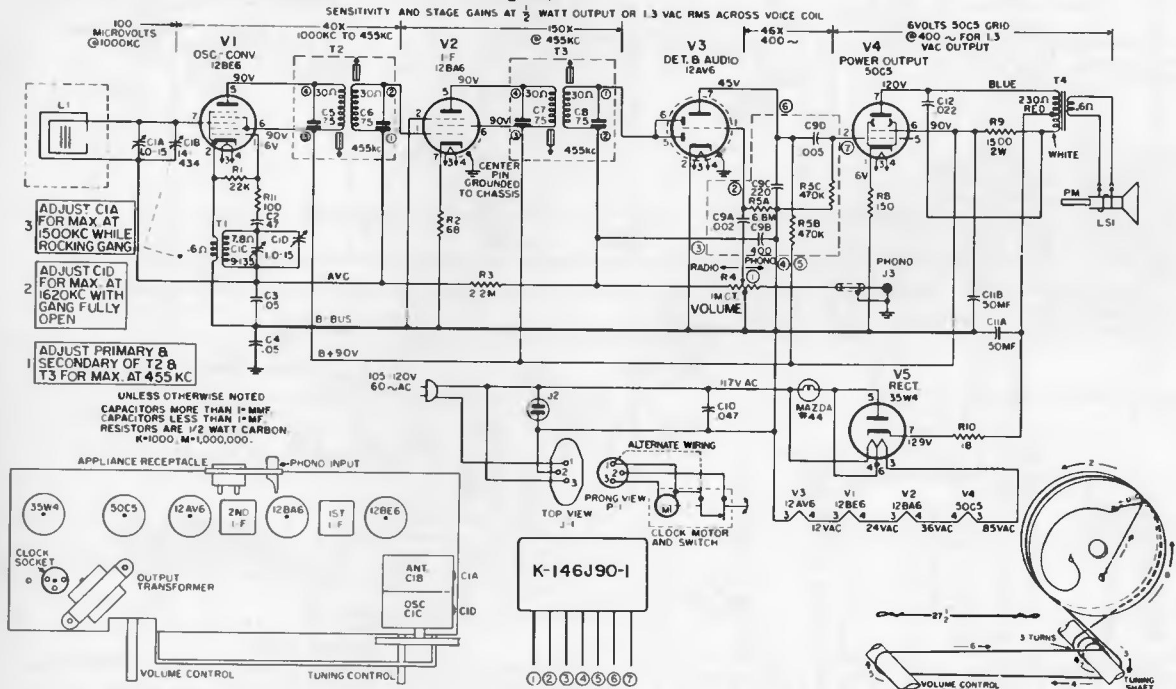

GENERAL ELECTRIC

**CLOCK-RADIO
MODELS
920
921**

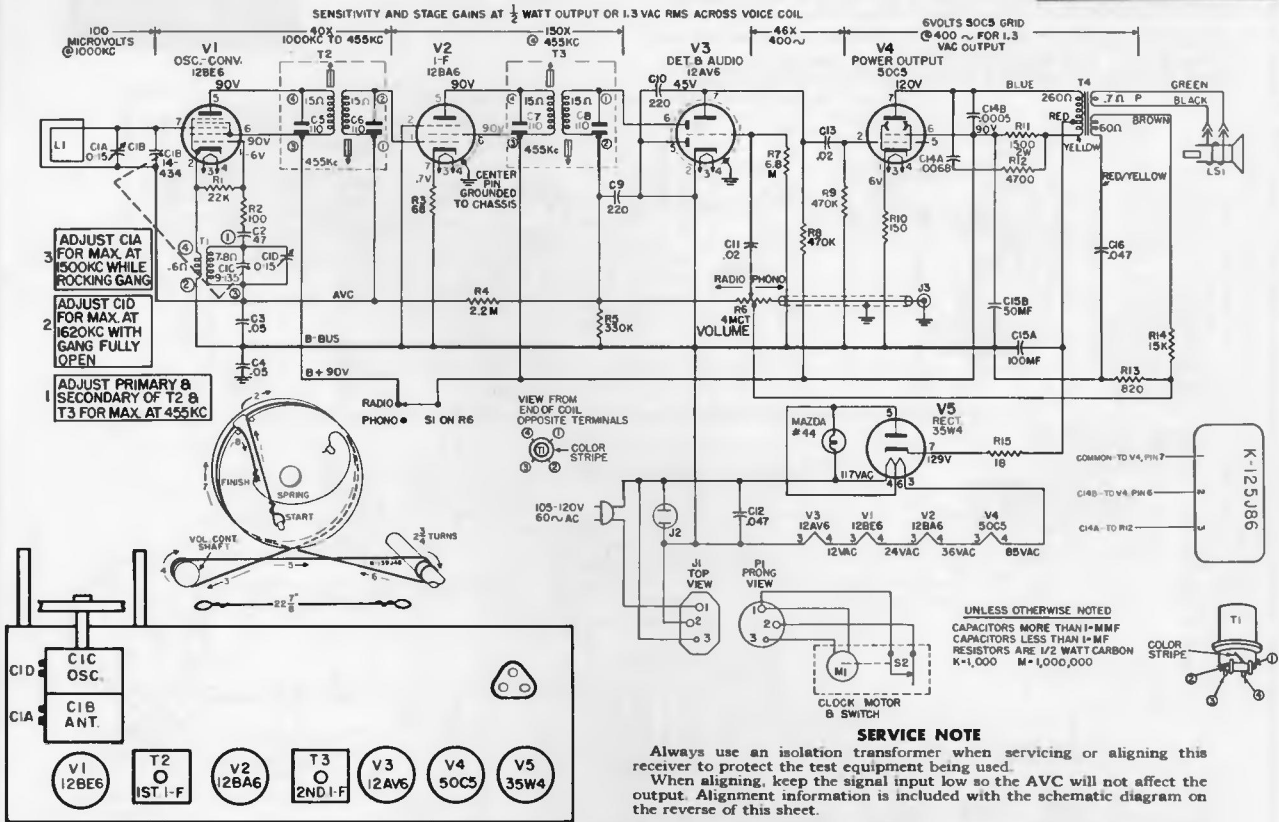

SERVICE NOTE
Always use an isolation transformer when servicing or aligning this receiver to protect the test equipment being used.
When aligning, keep the signal input low so the AVC will not affect the output. Alignment information is included with the schematic diagram on the reverse of this sheet.

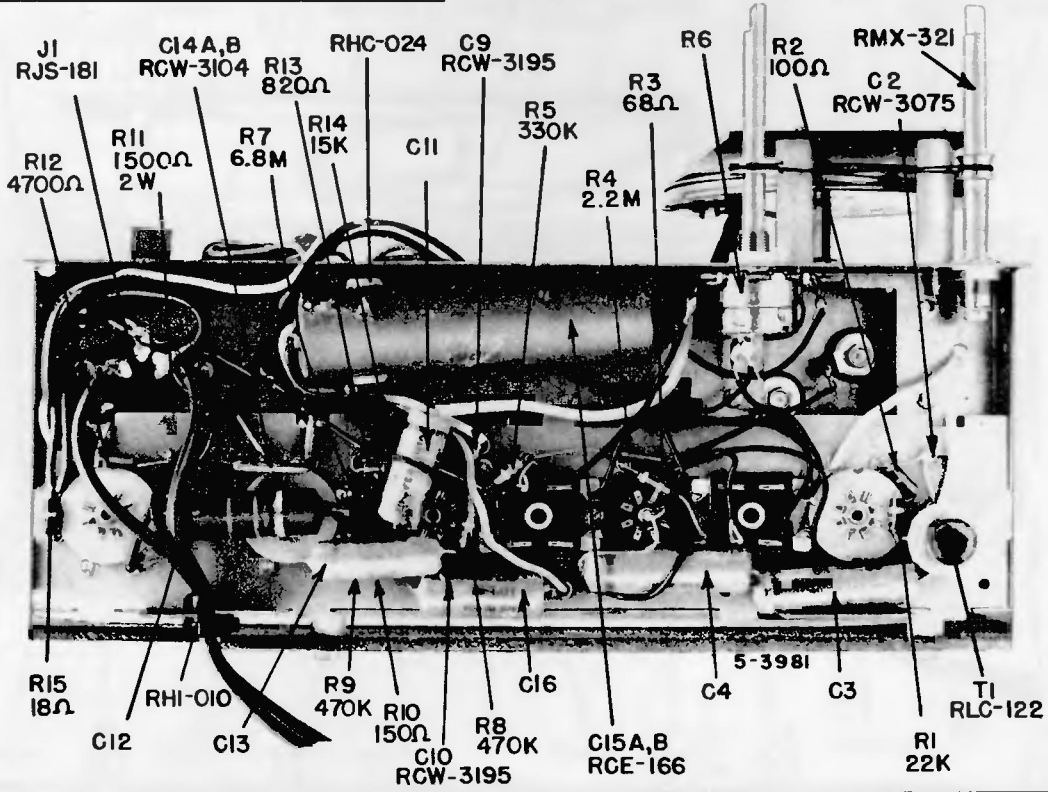

MODELS 5R70 & 5R71

the hallicrafters co. MODELS 5R72CL & 5R73CL

(Models 5R70, 5R71 omit clock circuit.)

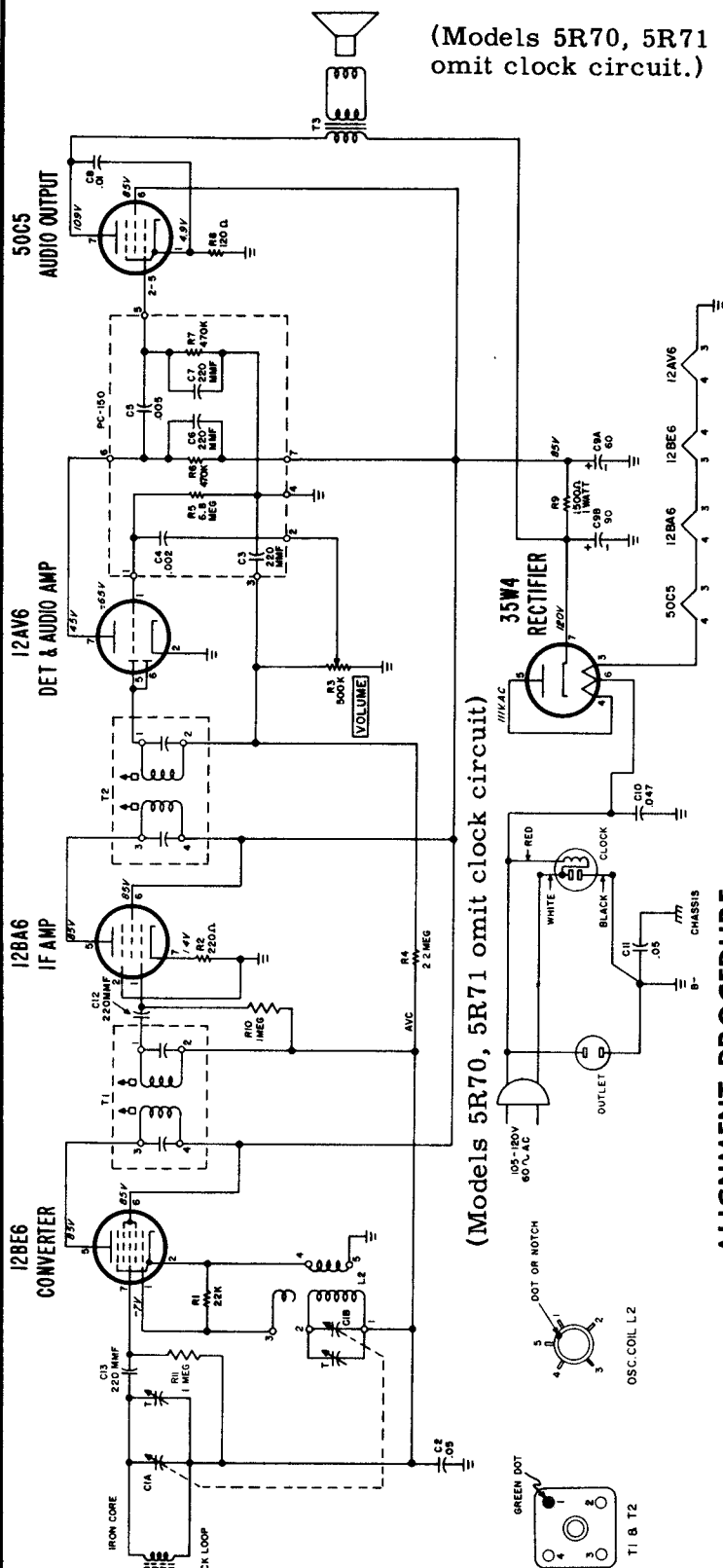

(Models 5R70, 5R71 omit clock circuit)

ALIGNMENT PROCEDURE

- Connect output meter across voice coil.
- Set volume control at maximum.
- Use a non-metallic alignment tool.
- Use generator with modulated output.
- Refer to Fig. 1 for location of alignment adjustments.
- To avoid AVC action use lowest output setting of generator that gives a satisfactory reading on meter.

Step	Signal Generator Connections	Generator Frequency	Gang Setting	Adjust for Maximum Output
1	High side thru .01 mfd. capacitor to stator plates of rear section of tuning gang. Low side to B--.	455 KC	1000 KC	Top & Bottom of 2nd I-F. Top & Bottom of 1st I-F.
2	Same as Step 1.	1620 KC	Fully Open.	(A) (osc. trimmer)
3	Connect a length of wire to the generator and use-couple other end to stick loop antenna. (Few turns of wire around stick loop.)	1400 KC	1400 KC	(B) (ant. trimmer)

- NOTES**
1. ALL RESISTORS ARE 1/2 WATT UNLESS OTHERWISE SPECIFIED.
 2. CAPACITOR VALUES IN MFD UNLESS OTHERWISE SPECIFIED.
 3. K-1000
- VOLTAGES**
- VOLTAGE READINGS ARE TAKEN UNDER THE FOLLOWING CONDITIONS
1. LINE VOLTAGE SET TO 117V, 60 AC.
 2. VOLTAGES ARE DC AND POSITIVE UNLESS OTHERWISE SPECIFIED.
 3. DC VOLTAGES ARE MEASURED WITH VTVM BETWEEN THE TUBE SOCKET TERMINALS AND B-- (1).

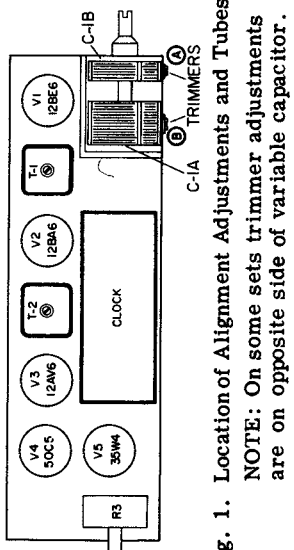
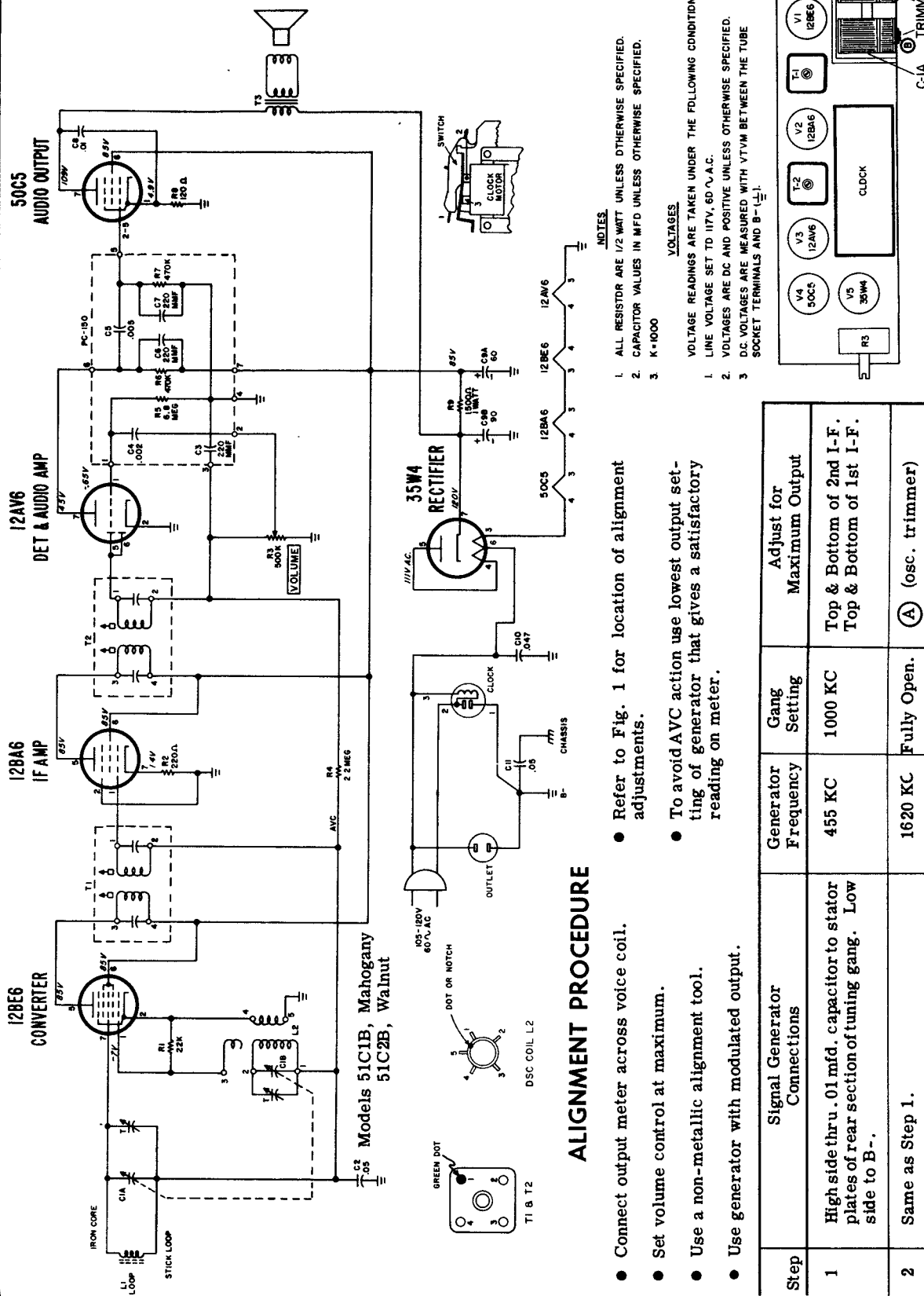

Fig. 1. Location of Alignment Adjustments and Tubes
NOTE: On some sets trimmer adjustments are on opposite side of variable capacitor.

the hallicrafters co.

MODELS 51C1B & 51C2B



the hallicrafters co.

MODELS TW-100, TW-101, TW-102

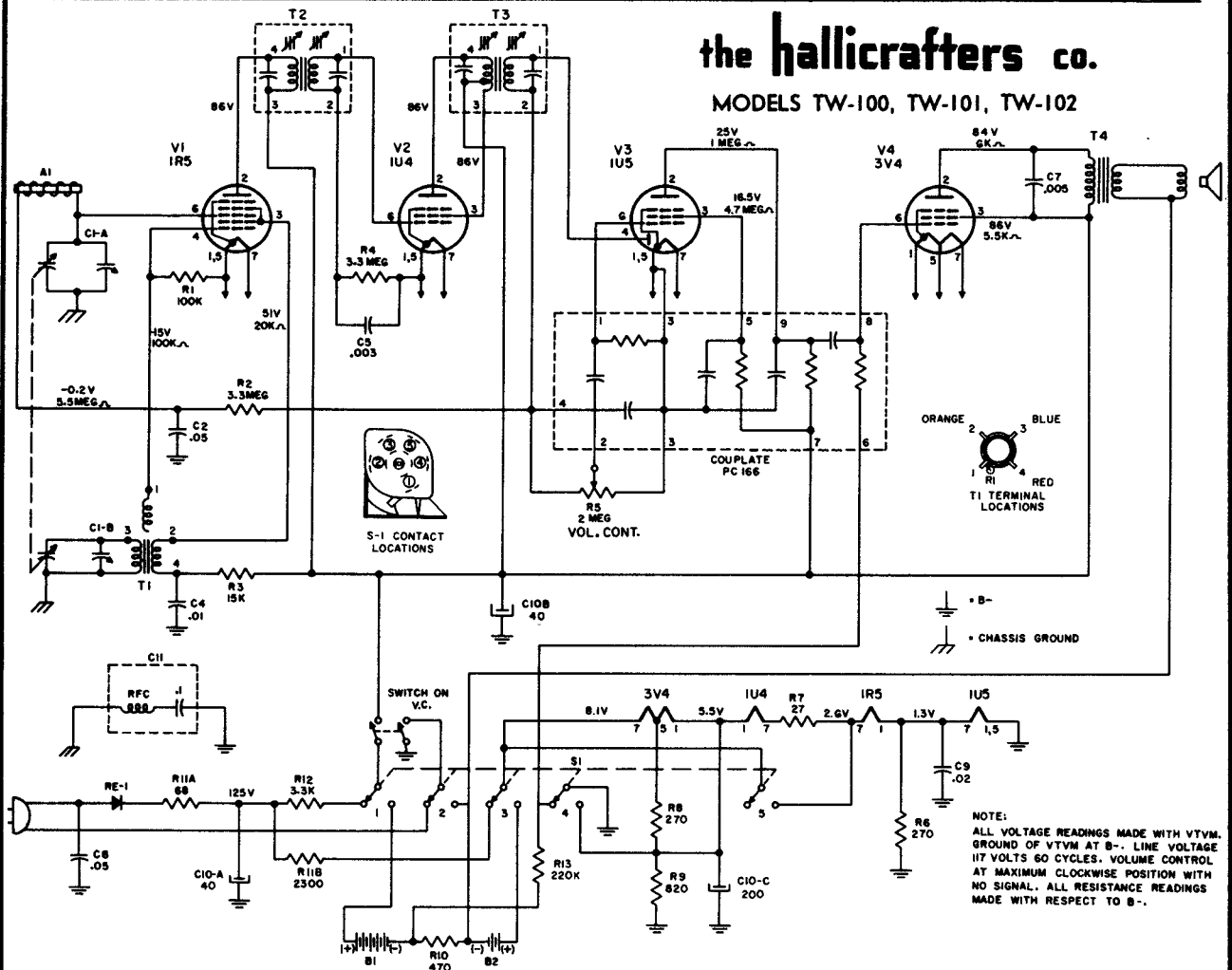

GENERAL ALIGNMENT PROCEDURE

1. Connect a low voltage A.C. voltmeter across the speaker voice coil.
2. Connect signal generator through a .05 mfd. capacitor to pin 6 of V-1, mixer/oscillator tube. (IR5) Connect generator ground lead to the B- line.
3. Rotate volume control to extreme clockwise position. (Maximum volume setting).
4. Adjust generator for 455 kc. output, amplitude modulated 30% at 400 cycles. Maintain output reading on meter constant at 0.4 volts by varying signal generator output.
5. Using a non-metallic adjustment tool, adjust primary and secondary of second I-F transformer (T-3) for maximum output.
6. Adjust primary and secondary of first I-F transformer (T-2) for maximum output.
7. Remove signal generator from pin 6 of V-1, and loosely couple generator output to ferrite stick antenna. (Wind a short length of insulated hookup wire loosely around the antenna coil several times, and connect generator output to one end of this wire). Generator ground lead remains connected to B- line.
8. Set generator to 1640 kc., 30% modulation at 400 cycles. Set receiver station selector to high end of band. (Tuning condenser fully open).
9. Adjust C-1B for maximum output.
10. Set generator to 1500 kc., 30% modulation at 400 cycles. Adjust station selector to 1500 kc.
11. Adjust C-1A for maximum output.
12. Set generator to 1000 kc. 30% modulation at 400 cycles. Adjust station selector to 1000 kc. Bring a piece of powdered iron (such as a coil slug) near the antenna loop stick until an indication is noted on the output meter. Repeat with a piece of brass. If the receiver output changes slightly, the receiver is tracking properly.
13. Repeat step 12 at 600 kc.

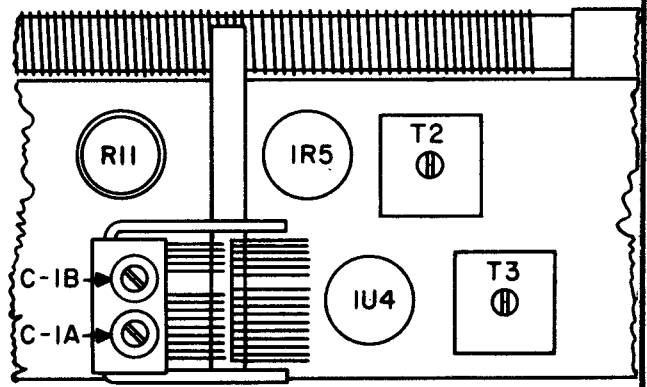

the hallicrafters co.

MODEL TW-200 SERIES
BROADCAST RECEIVER, AC-DC BATTERIES

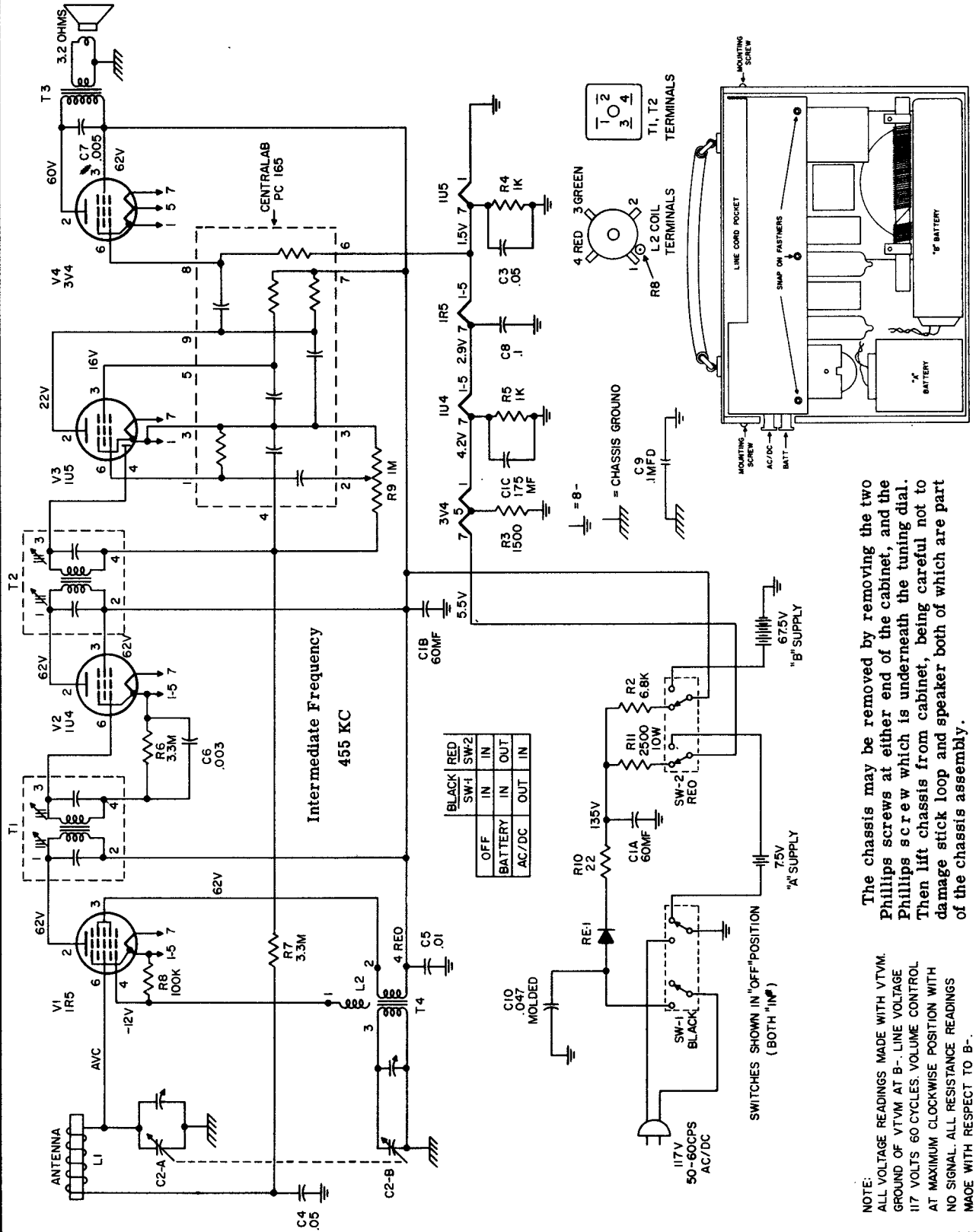

NOTE:
ALL VOLTAGE READINGS MADE WITH VTVM.
GROUND OF VTVM AT B- LINE VOLTAGE
117 VOLTS 60 CYCLES VOLUME CONTROL
AT MAXIMUM CLOCKWISE POSITION WITH
NO SIGNAL. ALL RESISTANCE READINGS
MADE WITH RESPECT TO B-.

The chassis may be removed by removing the two Phillips screws at either end of the cabinet, and the Phillips screw which is underneath the tuning dial. Then lift chassis from cabinet, being careful not to damage stick loop and speaker, both of which are part of the chassis assembly.

the hallicrafters co.

MODELS 3HFP-1 & 3HFP-2 RUN 1

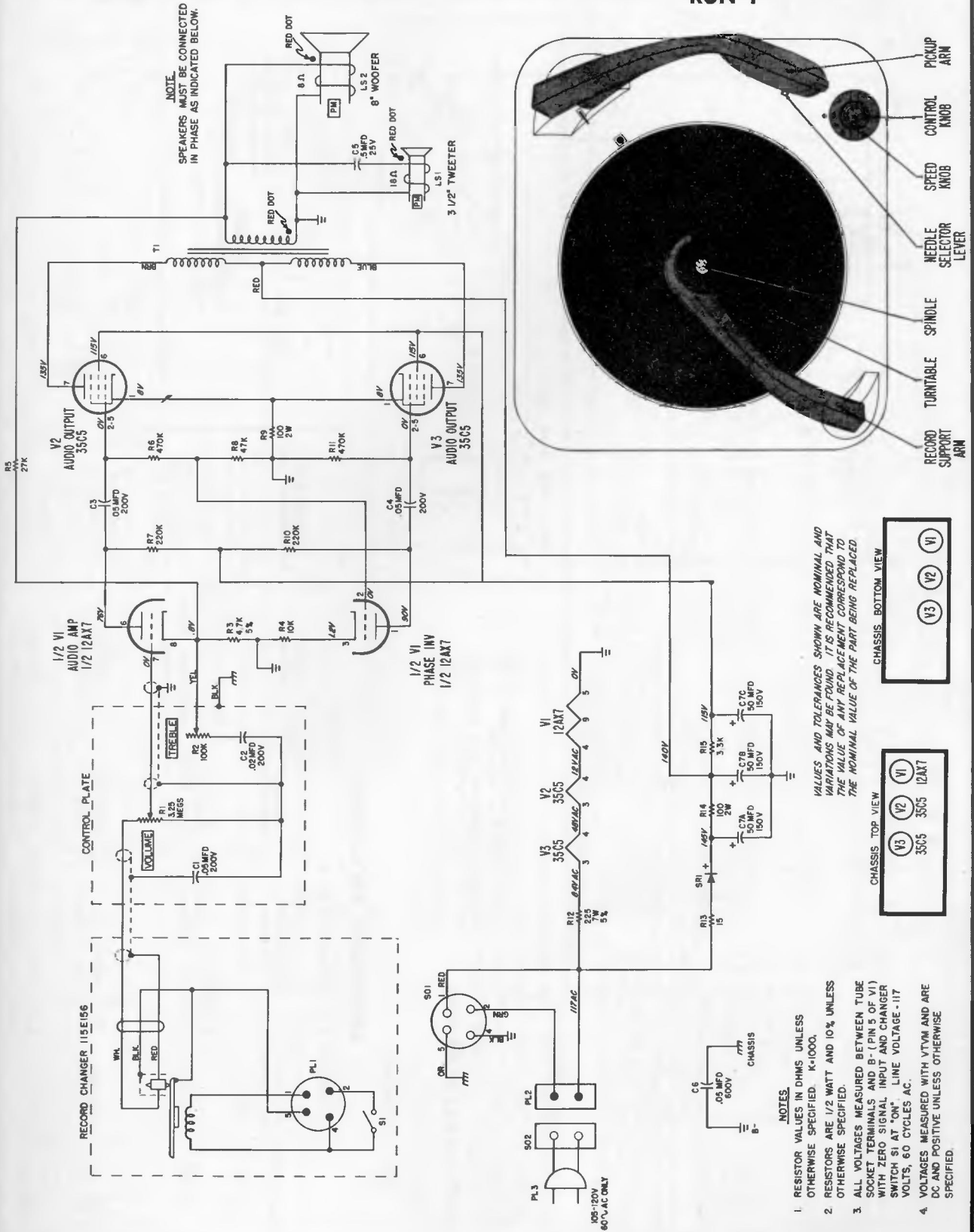

MONTGOMERY WARD Models GSL-1581A, GSL-1582A

This material also applies to **Models GSL-1650A, GSL-1651A,** which are electrically identical, but have different physical layout.

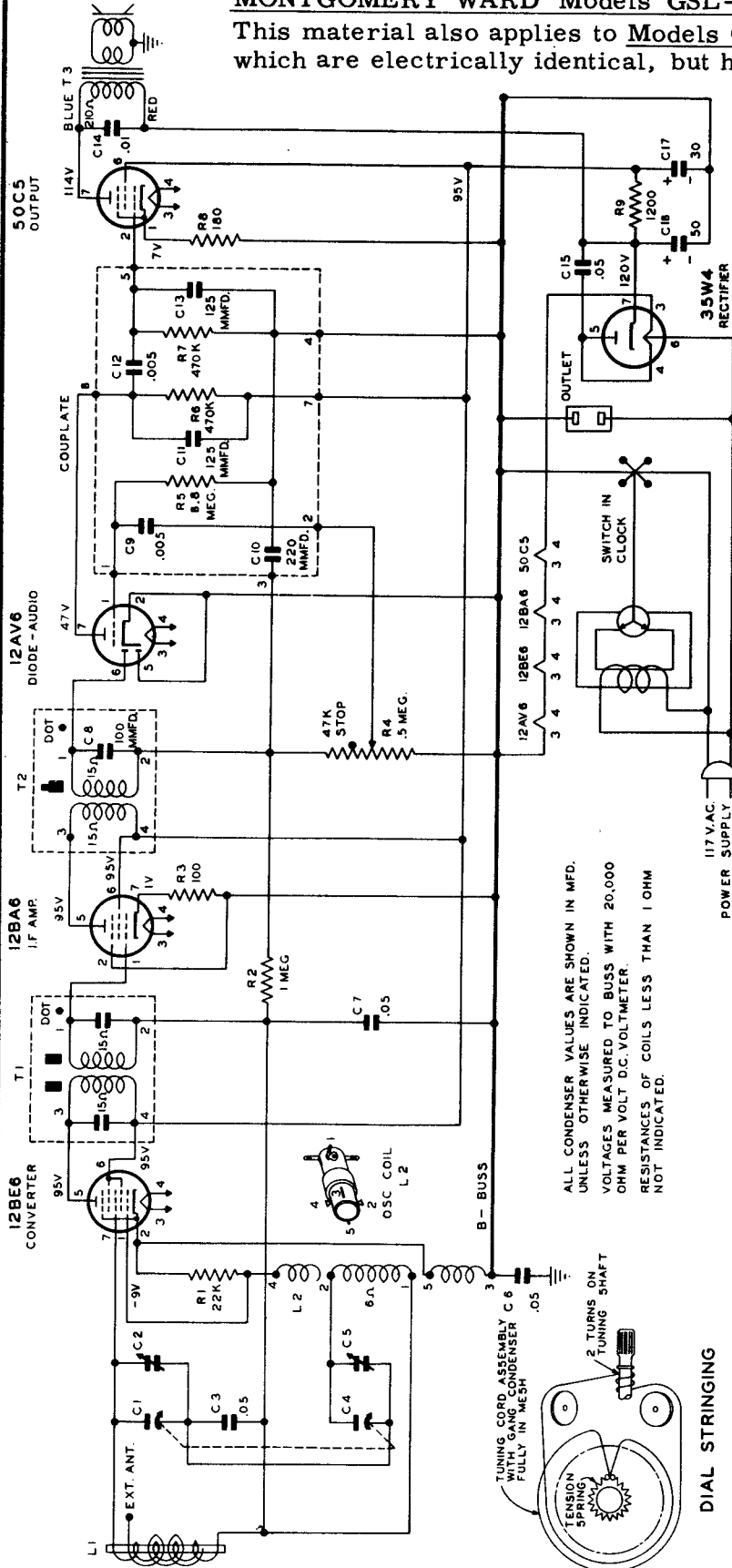

ALIGNMENT PROCEDURE

SIGNAL GENERATOR			TUNER SETTING	ADJUST FOR MAXIMUM OUTPUT
FREQUENCY	COUPLING CAPACITOR	CONNECTION TO RADIO		
455 Kc	.05 Mfd.	Rear stator plates of tuning condenser.	Any point near center where no interfering signal is received.	Slugs at top and bottom of I. F. Coil (T-1) and (T-2)
1620 Kc	.05 Mfd.	Rear stator plates of tuning condenser.	Exactly 1620 Kc.	Oscillator trimmer of Gang. (C5)
1400 Kc	---	Lay Generator lead near back of cabinet.	Exactly 1400 Kc.	Antenna trimmer of Gang. (C2)

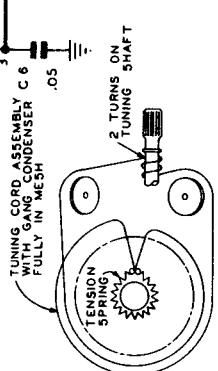
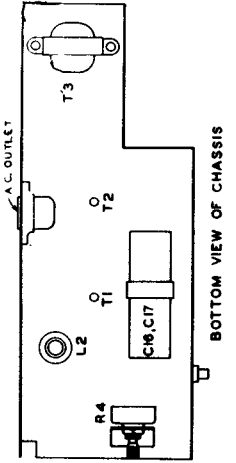
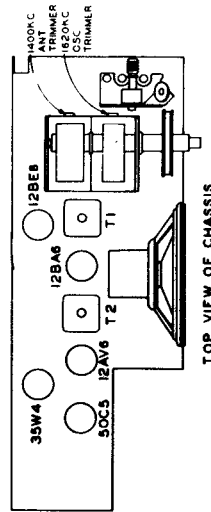

MONTGOMERY WARD
Models WG-1635A, WG-1636A

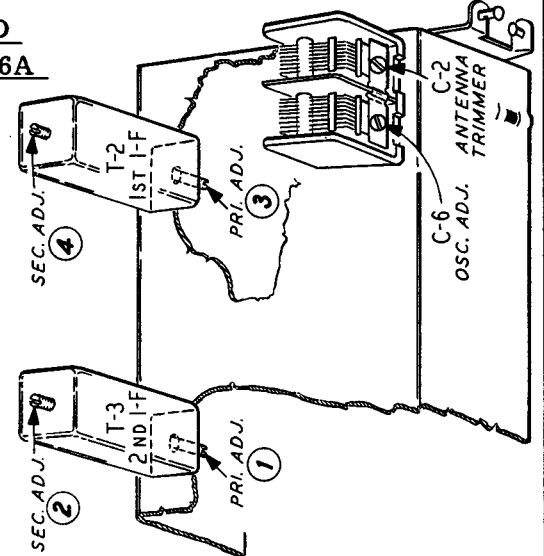
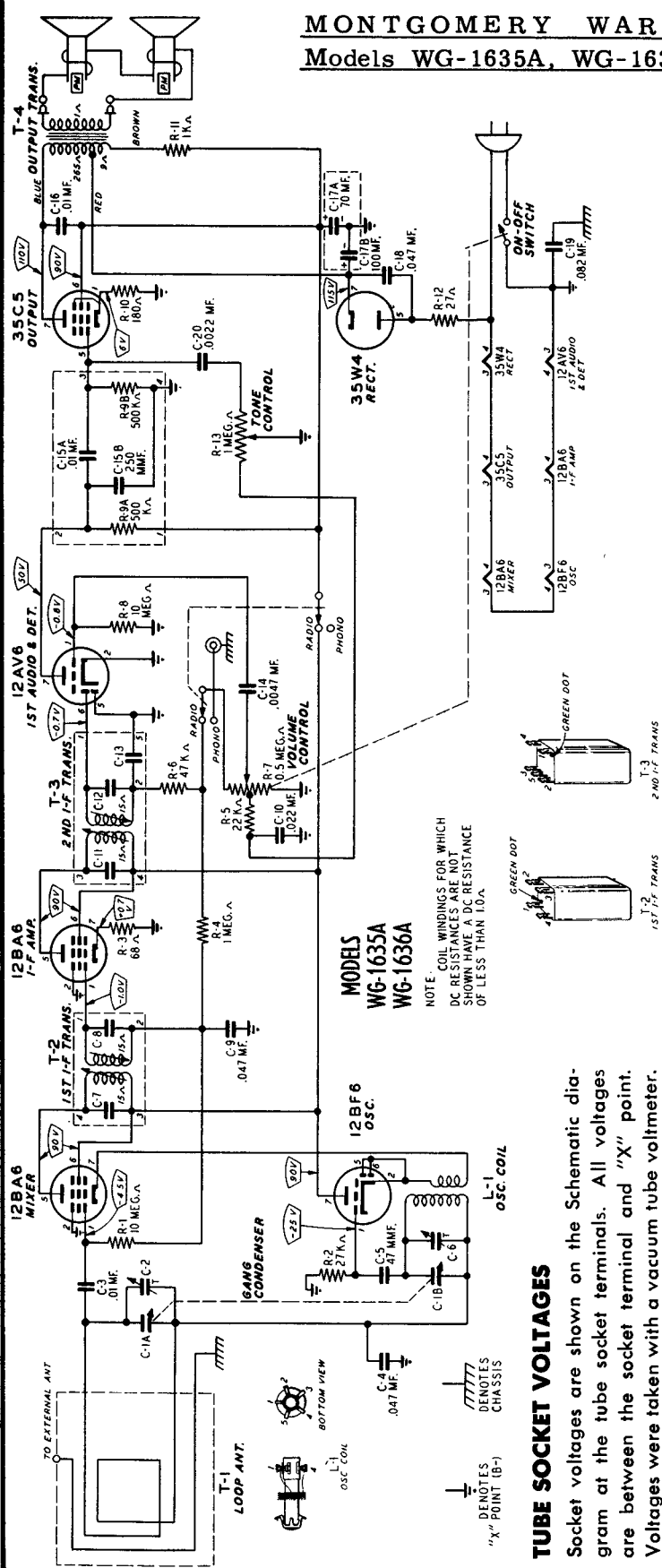

ALIGNMENT PROCEDURE
 Dummy Antennas—.1 mf., 50 mmf.
 Volume Control—Maximum All Adjustments.
 Allow Chassis and Signal Generator to "Heat Up" for several Minutes.

TUBE SOCKET VOLTAGES

Socket voltages are shown on the Schematic diagram at the tube socket terminals. All voltages are between the socket terminal and "X" point. Voltages were taken with a vacuum tube voltmeter.

FREQUENCY SETTING	SIGNAL GENERATOR		DUMMY ANTENNA	GANG CONDENSER SETTING	ADJUST TUNING SLUGS (I.F.) AND TRIMMERS TO MAXIMUM
	ANTENNA CONNECTION	GROUND CONNECTION			
455 KC	Control Grid 12BA6-I.F. Prong No. 1	"X" Point	.1 mf.	Turn Rotor to full open	2nd I.F. Pri. (1) & Sec. (2)
455 KC	Control Grid 12BA6 Mixer Prong No. 1	"X" Point	.1 mf.	Turn Rotor to full open	1st I.F. Pri. (3) & Sec. (4)
1620 KC	Control Grid 12BA6 Mixer Prong No. 1	"X" Point	.1 mf.	Turn Rotor to full open	2nd I.F. Pri. (1) & Sec. (2)
1400 KC	External Antenna Clip On Loop	Chassis	50 mmf.	Tune Receiver to 1400 KC.	Oscillator (C-6) Antenna (C-2) Trimmer

MOTOROLA

HOME RADIO

MODELS	CHASSIS
56H1 Mahogany	HS-431
56H2 White	HS-431
56H3 Green	HS-431
56H4 Turquoise	HS-431

MODELS	CHASSIS
56R1 Ebony	HS-487
56R2 White	HS-487
56R3 Red	HS-487
56R4 Green	HS-487

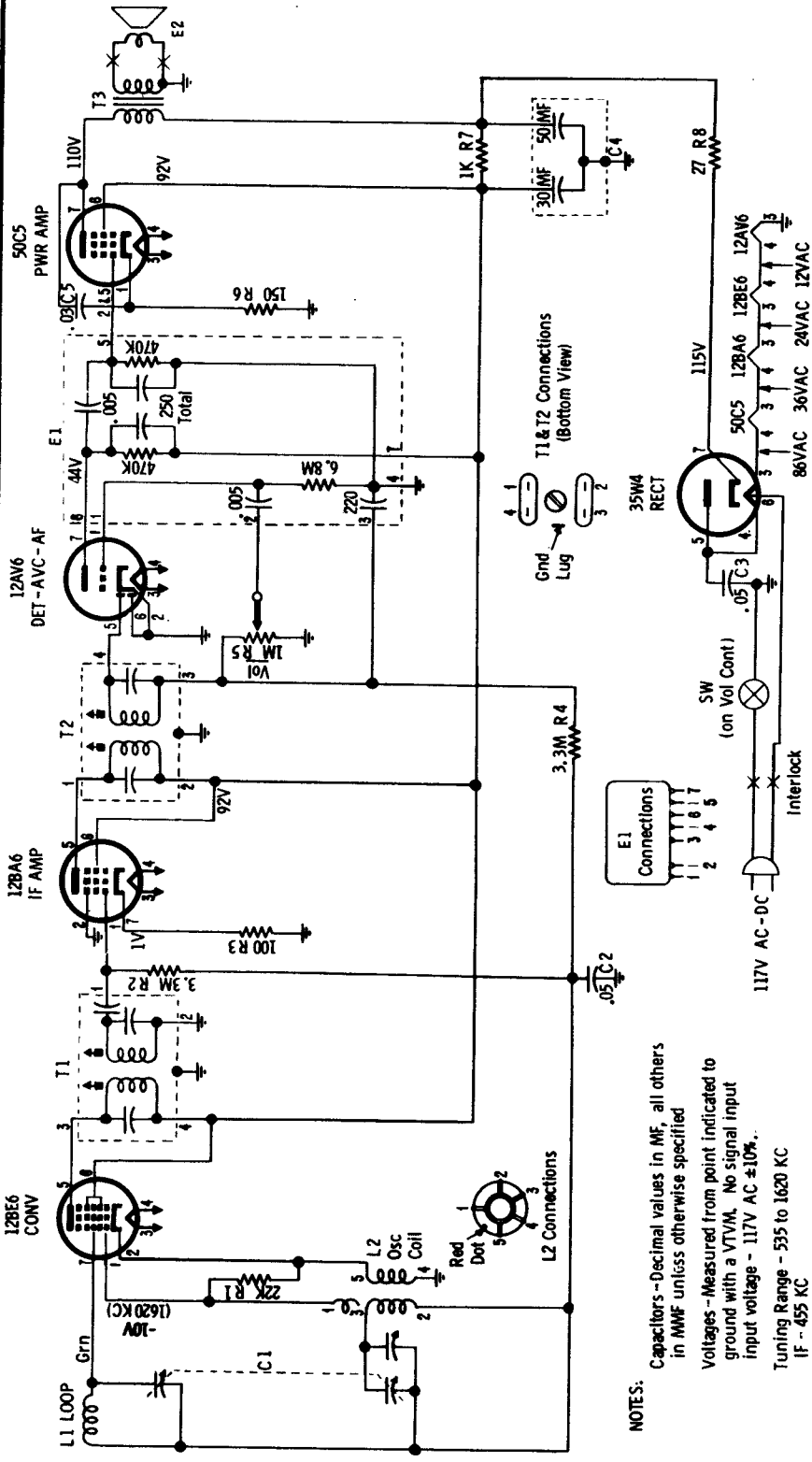

ALIGNMENT

Use an isolation transformer between the power line and the receiver. If not available, connect low side of generator to ground (outer chassis edges) through a .1 mf capacitor. Temporarily connect speaker through jumpers. Connect a low range output meter across speaker voice coil and set volume control to maximum. Attenuate generator output to maintain .40 volts on output meter to prevent overloading.

STEP	DUMMY ANTENNA	GENERATOR CONNECTION	GENERATOR FREQUENCY (400 cycle mod)	GANG SETTING	ADJUST	REMARKS
1.	.1 mf	Grid of conv. (pin 7, 12BE6)	455 Kc	Fully open	1, 2, 3 & 4 (IF cores)	Adjust for maximum. Use insulated screwdriver.
2.	.1 mf	Grid of conv. (pin 7, 12BE6)	1620 Kc	Fully open	5 (Osc)	Adjust for maximum.

- NOTES:**
- Capacitors - Decimal values in MF, all others in MMF unless otherwise specified
 - Voltages - Measured from point indicated to ground with a VTVM. No signal input input voltage - 117V AC ±10%.
 - Tuning Range - 535 to 1620 KC IF - 455 KC

MOTOROLA

MODELS	CHASSIS	MODEL	CHASSIS	MODELS	CHASSIS
56CC1	White HS-457	56CE1	Ebony HS-490	56CJ1	Ebony HS-499
56CC2	Green HS-457	56CS1	Mahogany HS-490	56CJ2	White HS-499
56CD1	Mahogany HS-457	56CS2	White HS-490		
56CD2	White HS-457	56CS3	Red HS-490		
56CD3	Pink HS-457	56CS4	Green HS-490		
56CD4	Turquoise HS-457				

The three groups of sets listed above are electrically similar. The clock-switching unit and appliance outlet connections to 35W4 may differ somewhat. Chassis HS-499 omits R9, 27-ohm resistor. Chassis HS-490 omits R6 and C4, and there is no RF trimmer adjustment.

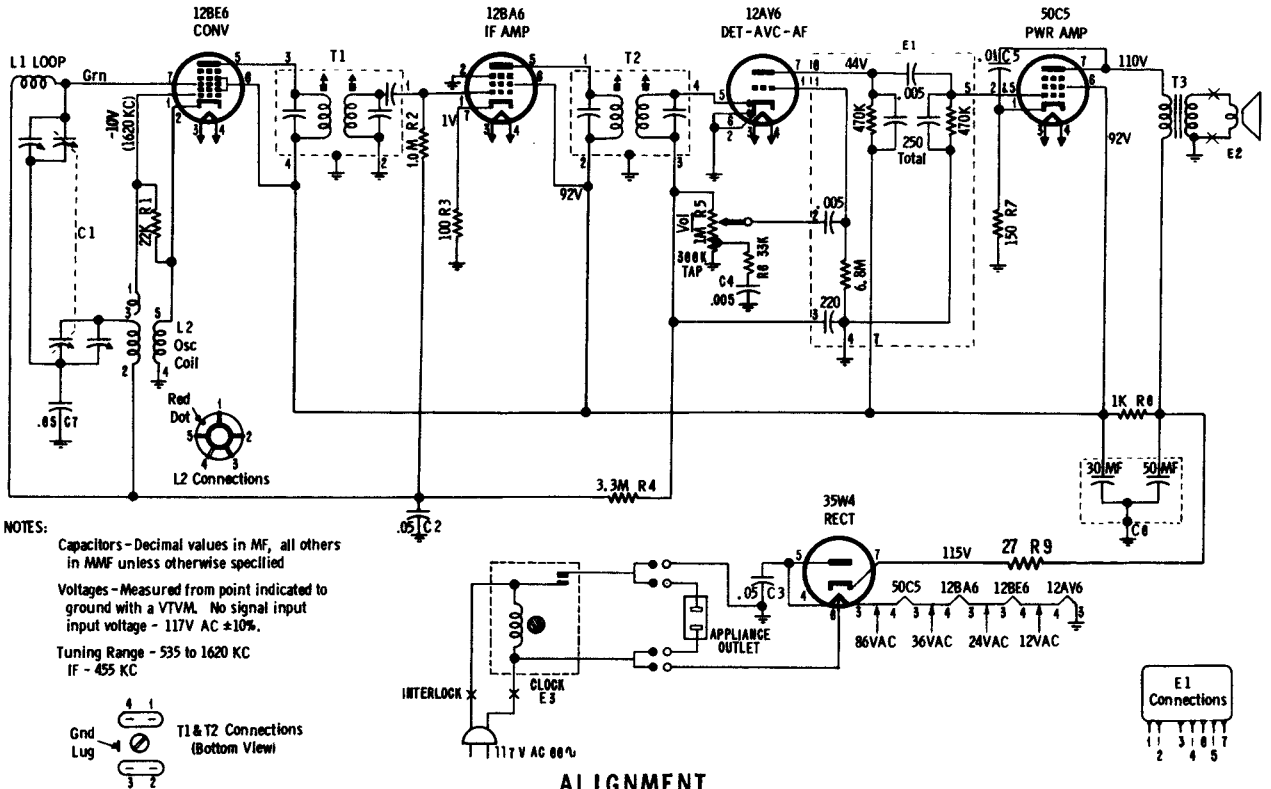

STEP	DUMMY ANTENNA	GENERATOR CONNECTION	GENERATOR FREQUENCY (400 cycle mod)	GANG SETTING	ADJUST	REMARKS
IF ALIGNMENT 1.	.1 mf	Grid of conv. (pin 7, 12BE6)	455 Kc	Fully open	1, 2, 3 & 4 (IF cores)	Adjust for maximum. Use insulated screwdriver.
OSC ALIGNMENT 2.	.1 mf	Grid of conv. (pin 7, 12BE6)	1620 Kc	Fully open	5 (Osc)	Adjust for maximum.
RF ALIGNMENT 3. #:	-	Radiation loop*	1400 Kc	Tune for max	6 (RF)	Adjust for maximum

*Connect generator output across 5" diameter, 5 turn loop and couple inductively to receiver loop. Keep loops at least 12" apart.

Step 3, RF alignment is not required for Chassis HS-490.

MOTOROLA

MODELS CHASSIS
 66C1 Ivory HS-458
 66C2 Gray HS-458

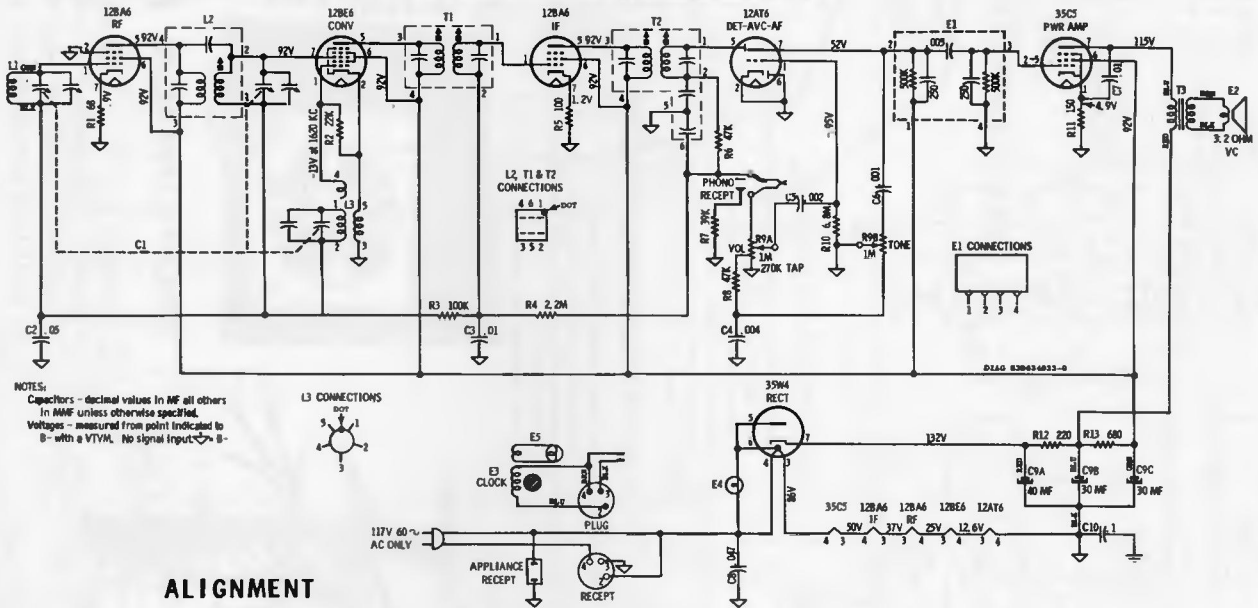

ALIGNMENT

Use an isolation transformer between the power line and the receiver. If not available, connect low side of generator to chassis through a .1 mf capacitor. Temporarily connect the clock, antenna and speaker to radio. Connect a low range output meter across the voice coil and set volume control to maximum and tone control to treble. Attenuate generator output to maintain .4 volts on output meter at all times to prevent overloading; if noise is too high during radiation measurements use 1.25 volt output.

STEP	DUMMY ANTENNA	GENERATOR CONNECTION	GENERATOR FREQUENCY (400 cycle mod)	GANG SETTING	ADJUST	REMARKS
IF ALIGNMENT						
1.	.1 mf	Grid of conv. (pin 7, 12BE6)	455 Kc	Fully open	1, 2, 3 & 4 (IF cores)	Adjust for maximum.
RF ALIGNMENT						
2.	.1 mf	Grid of conv. (pin 7, 12BE6)	1620 Kc	Fully open	5 (Osc trim)	Adjust for maximum.
3.	-	Radiation loop*	1400 Kc	Tune for max	6 (RF trim) & 7 (Ant trim)	Remove dial scale background to make trimmers accessible. Adjust for maximum.
4.	-	Radiation loop*	600 Kc	Tune for max	8 (RF core)	Adjust for maximum.
5.	-	Radiation loop*	1400 Kc	Tune for max	6 (RF trim)	Adjust for maximum.

*Connect generator output across 5" diameter, 5 turn loop and couple inductively to receiver loop. Keep loops at least 12" apart.

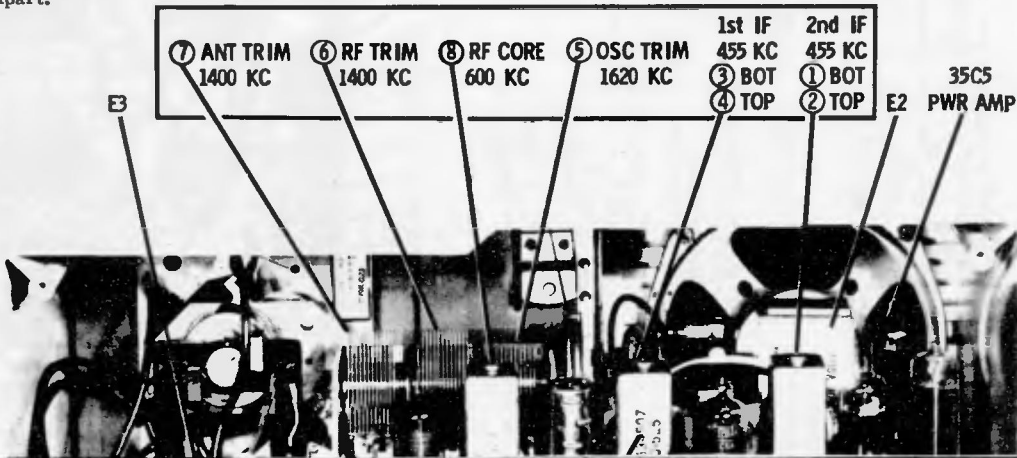

MOTOROLA

MOTOROLA

MODELS CHASSIS
 56W1 Mahogany HS-476
 56W1B Lined Oak HS-476

MODEL CHASSIS
 56X1 Mahogany HS-477
 56X2 Ivory HS-477
 56X3 Green HS-477

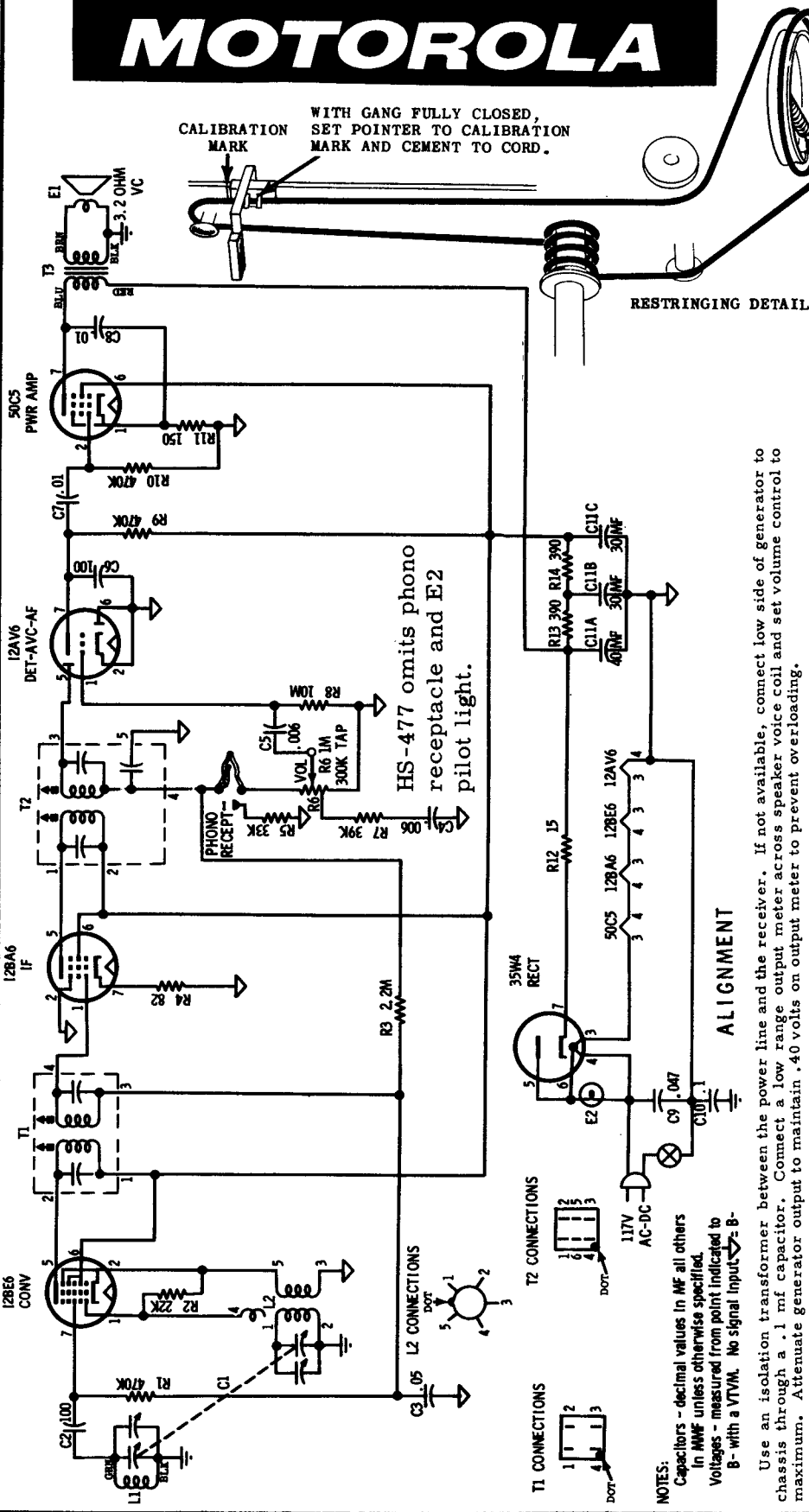

STEP	DUMMY ANTENNA	GENERATOR CONNECTION	GENERATOR FREQUENCY (400 cycle mod)	GANG SETTING	ADJUST	REMARKS
IF ALIGNMENT 1.	.1 mf	Grid of conv. (pin 7, 12BE6)	455 Kc	Fully open	1, 2, 3 & 4 (IF cores)	Adjust for maximum. Use insulated screwdriver.
OSC ALIGNMENT 2.	.1 mf	Grid of conv. (pin 7, 12BE6)	1620 Kc	Fully open	5 (Osc)	Adjust for maximum.
RF ALIGNMENT 3.	-	Radiation loop*	1400 Kc	Tune for max	6 (Ant)	Adjust for maximum.

*Connect generator output across 5" diameter, 5 turn loop and couple inductively to receiver loop. Keep loops at least 12" apart.

MOTOROLA

MODELS CHASSIS
 66X1 Mahogany HS-478
 66X2 Ivory HS-478

CALIBRATION MARK

WITH GANG FULLY CLOSED, SET POINTER TO CALIBRATION MARK AND CEMENT TO CORD.

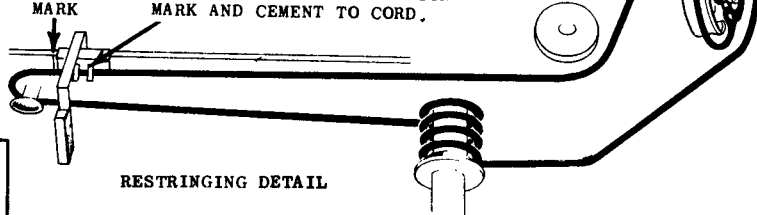

RESTRINGING DETAIL

THE SPEAKERS MUST BE IN PHASE OR A LOSS OF LOW FREQUENCIES WILL RESULT.

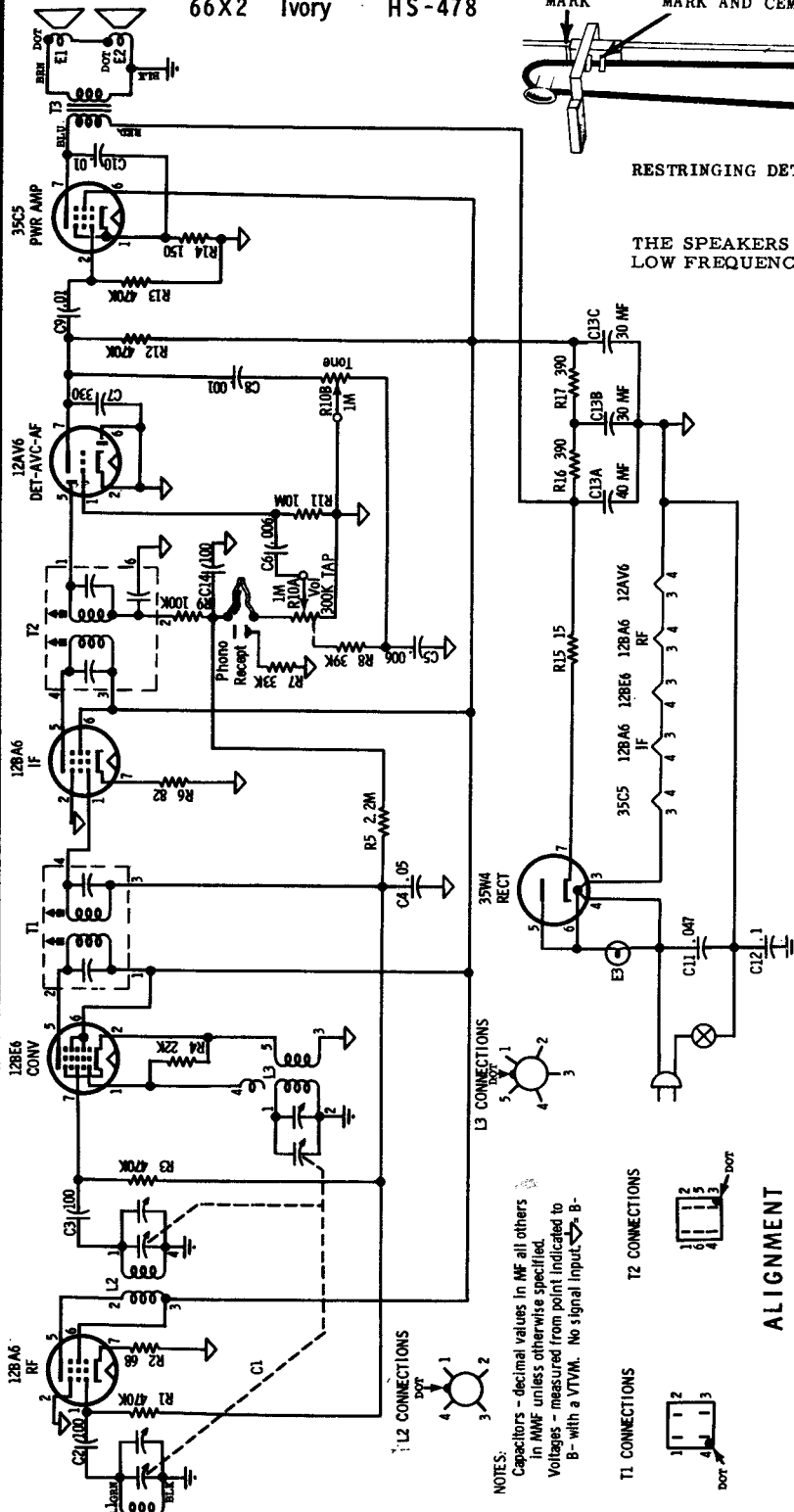

NOTES:

Capacitors - decimal values in MF all others in MMF unless otherwise specified.
 Voltages - measured from point indicated to B - with a VTVM. No signal input.

L3 CONNECTIONS

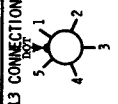

L2 CONNECTIONS

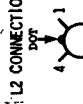

T1 CONNECTIONS



T2 CONNECTIONS



ALIGNMENT

Use an isolation transformer between the power line and the receiver. If not available, connect low side of generator to chassis through a .1 mf capacitor. Connect speakers and a low range output meter across output transformer secondary and set volume control to maximum. Attenuate generator output to maintain .565 volts on output meter to prevent overloading.

STEP	DUMMY ANTENNA	GENERATOR CONNECTION	GENERATOR FREQUENCY (400 cycle mod)	GANG SETTING	ADJUST	REMARKS
1.	.1 mf	Grid of conv. (pin 7, 12BE6)	455 Kc	Fully open	1, 2, 3 & 4 (IF cores)	Adjust for maximum. Use insulated screwdriver.
2.	.1 mf	Grid of conv. (pin 7, 12BE6)	1620 Kc	Fully open	5 (Osc)	Adjust for maximum.
3.	-	Radiation loop*	1400 Kc	Tune for max	6 (RF)	Adjust for maximum.
4.	-	Radiation loop*	1400 Kc	Tune for max	7 (Ant)	Adjust for maximum.

*Connect generator output across 5" diameter, 5 turn loop and couple inductively to receiver loop. Keep loops at least 12" apart.

MOTOROLA

Model 56T1
Chassis HS-483

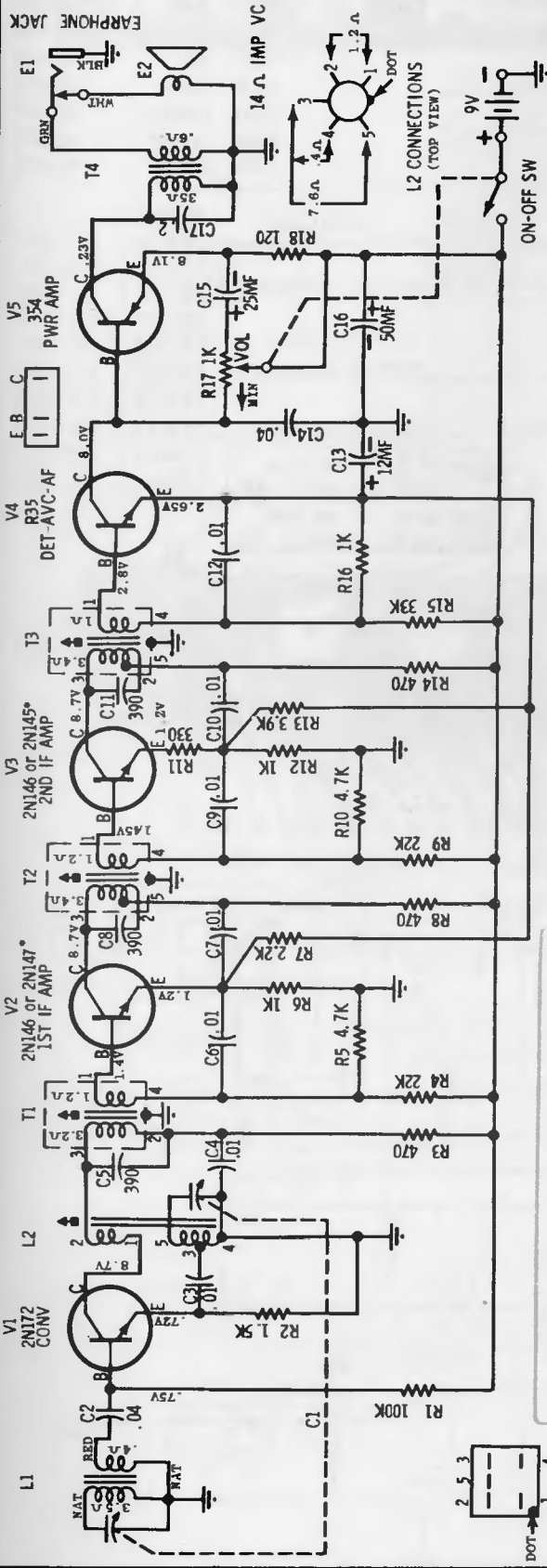

MOTOROLA

Model 56T1, Chassis HS-483

CHASSIS REMOVAL

1. Pull the volume control knob from front of radio.
2. Remove tuning knob retaining screw from the tuning knob and remove the tuning knob (see cover photo).
3. Remove chassis mounting screw from under tuning knob (see cover photo).
4. Open rear cover and unsolder grounding braid from top of 1st IF transformer and capacitor C13. Care should be taken so that the IF can is not overheated, otherwise damage to the IF transformer will result.
5. Turn handle perpendicular to the plated chassis.

6. Grasp handle near one of its two mounting bushings and pull out from side of cabinet until the round portion of the mounting bushing clears hole in side of cabinet, then lift this side of handle and chassis slightly out of cabinet. Perform the same procedure on the other mounting bushing, then lift handle, chassis and speaker plate out of cabinet.
7. The plated chassis is separated from the speaker mounting plate as follows: loosen the gang mounting screws and with a small soldering iron (60 watts or less) separate gang oscillator stator terminal from plated chassis. Then unsolder, one at a time, the three chassis mounting support lugs. USE ONLY A SMALL SOLDERING IRON - 60 WATTS OR LESS. Disconnect speaker, earphone jack and antenna leads as required.

NOTES:
Capacitors - Decimal values in MF, all others in MMF unless otherwise specified.
Voltages - Measured from point indicated to braided lead (ground) with a VTVM. No signal input, vol. at max. Tuning range - 530 to 1620 KC.

• Use either a pair of 2N146's for the 1st and 2nd IF amplifiers or a 2N147 for the 1st IF AMP and a 2N145 for the 2nd IF AMP. Use no other combinations. Resistances measured with transistor out of associated circuit.

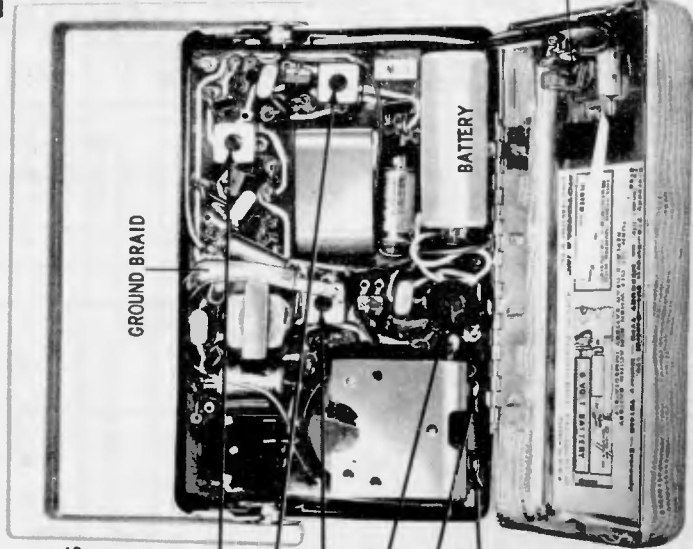
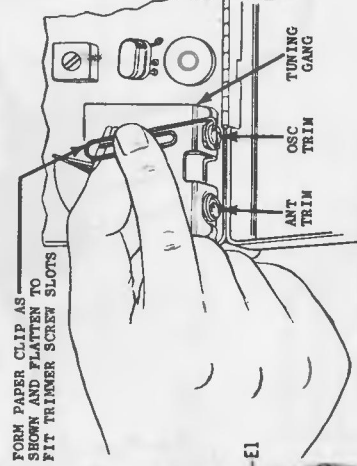

- 2ND IF 455 KC
- 3RD IF 495 KC
- 1ST IF 455 KC
- OSC CORE 530 KC
- OSC TRIM 1620 KC
- ANT TRIM 1400 KC

T1, T2, & T3 CONNECTIONS



MOTOROLA

Models 55B1U, 55L1U, 55L2U, 55L3U, 55L4U, 55M1U, 55M2U & 55M3U are the same as models 55B1, 55L1, 55L2, 55L3, 55L4, 55M1, 55M2 & 55M3 except that the "U" versions use a different power switch S-1. This switch has an additional section which opens the + "A" lead to the filament, pin 7, of the 3V4 during line power operation.

MODELS	CHASSIS
55B1	Brown HS-486
55L1	Black HS-470
55L2	Green HS-470
55L3	Red HS-470
55L4	Blue HS-470
55M1	Black HS-472
55M2	Brown HS-472
55M3	Ivory HS-472

STEP	DUMMY ANTENNA	GENERATOR CONNECTION	GENERATOR FREQUENCY	GANG SETTING	ADJUST	REMARKS	MODELS
IF ALIGNMENT							55B1U HS-508
1.	.1 mf	Grid of conv (pin 6 of 1R5)	455 Kc	Fully open	1, 2, 3	Peak for maximum.	55L1U HS-509
RF ALIGNMENT							55L2U HS-509
2.	.1 mf	Grid of conv (pin 6 of 1R5)	1620 Kc	Fully open	4	Peak for maximum.	55L3U HS-509
							55L4U HS-509
3.	-	Radiation loop	1400 Kc	Tune for maximum	5	Peak for maximum.	55L5U HS-509
							55M1U HS-510
							55M2U HS-510
							55M3U HS-510
							55M4U HS-510

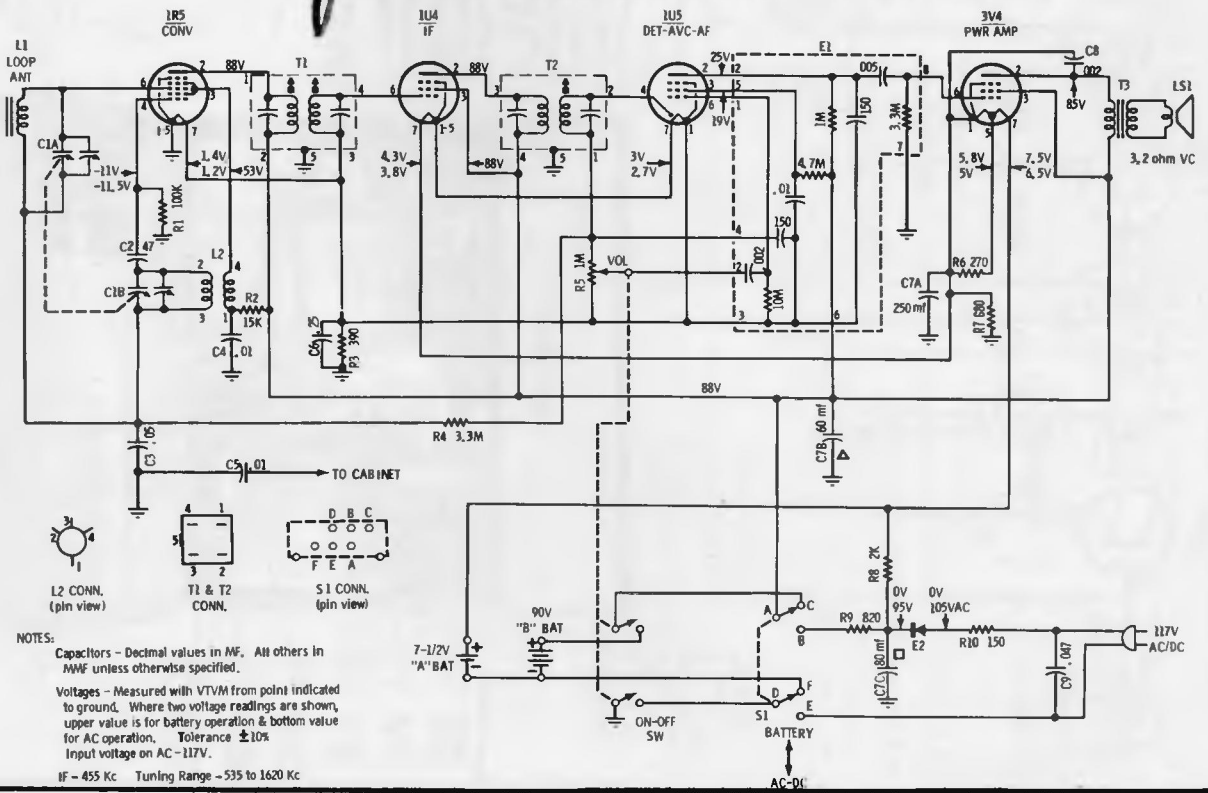
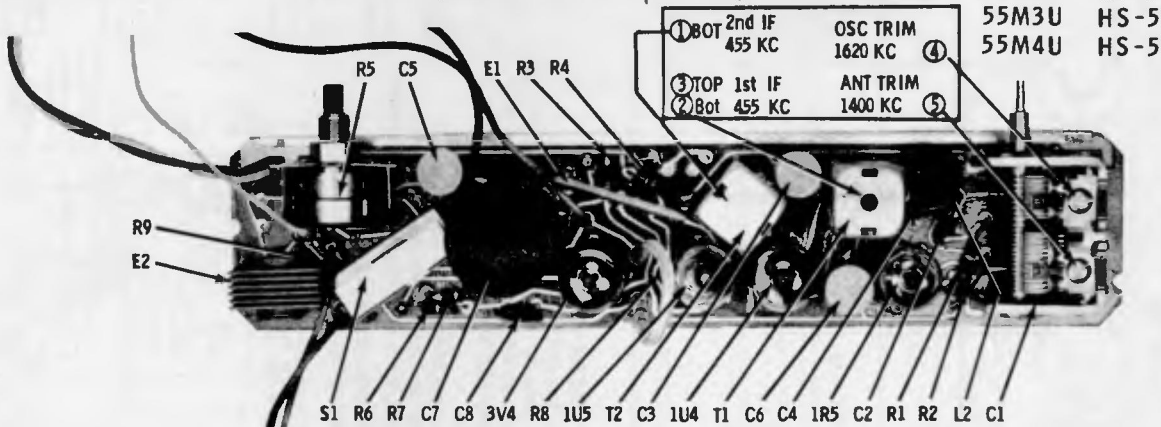

MOTOROLA

MODELS CHASSIS
 46HF1 Mahogany HS-495
 46HF1B Limed Oak HS-495
 46HF1D Mahogany HS-495
 46HF1BD Limed Oak HS-495

DISASSEMBLY INSTRUCTIONS

To Remove Chassis From Cabinet

1. Pull off three knobs from top of cabinet.
2. Remove three screws which hold perforated baffle and remove the perforated baffle.
3. Remove all leads connecting the chassis to the record changer.
4. Unsolder speaker leads connecting chassis to speakers at the 4" speaker.
5. Remove two nuts which hold the chassis to the cabinet and remove the chassis.

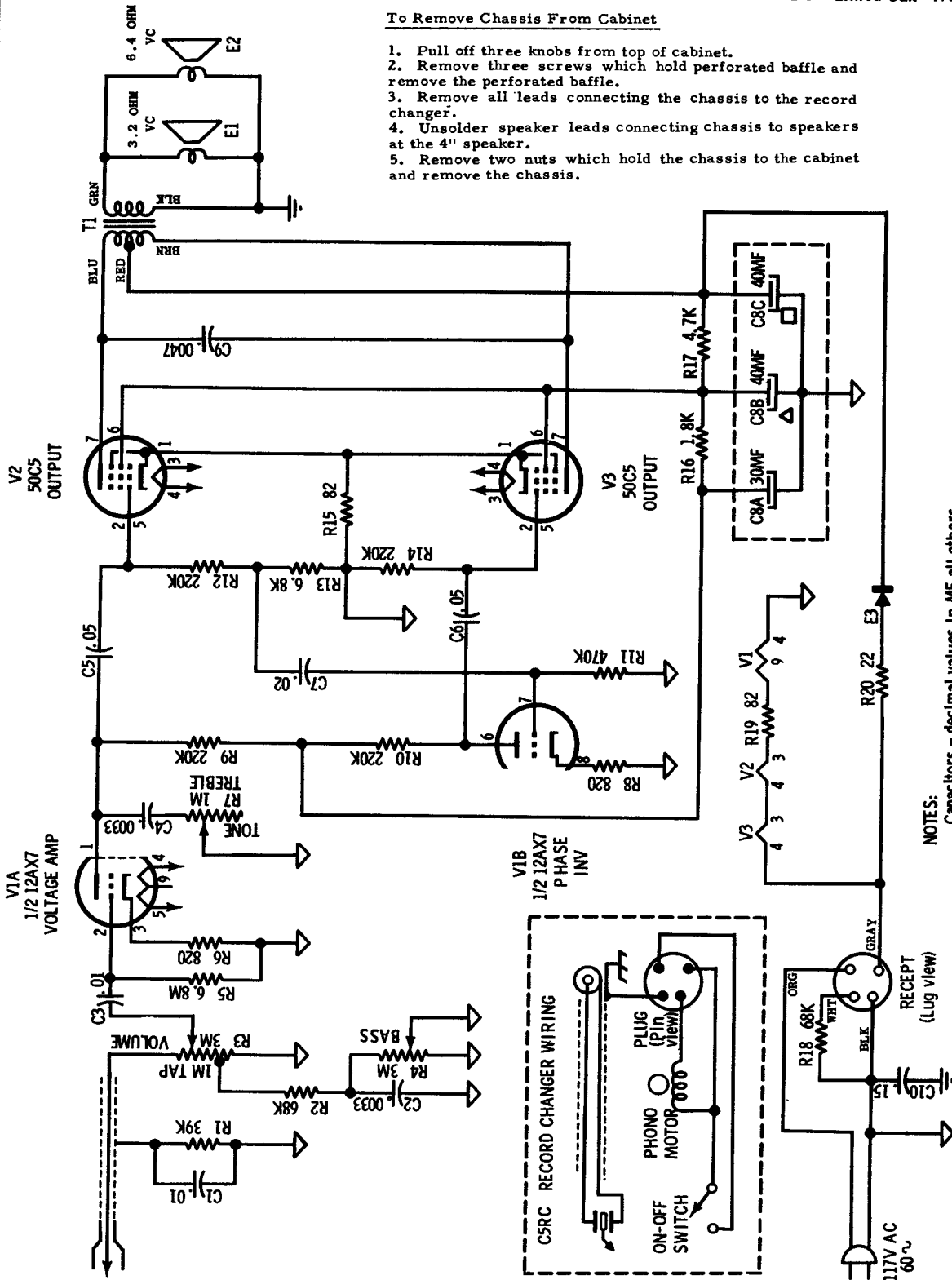

NOTES:
 Capacitors - decimal values in MF, all others in MMF unless otherwise specified.
 Voltages - measured from point indicated to B- with a VTVM. No signal input.

MOTOROLA

Models 36F1, 36F1C, 36F1G, Chassis HS-496, Two Tone Tan

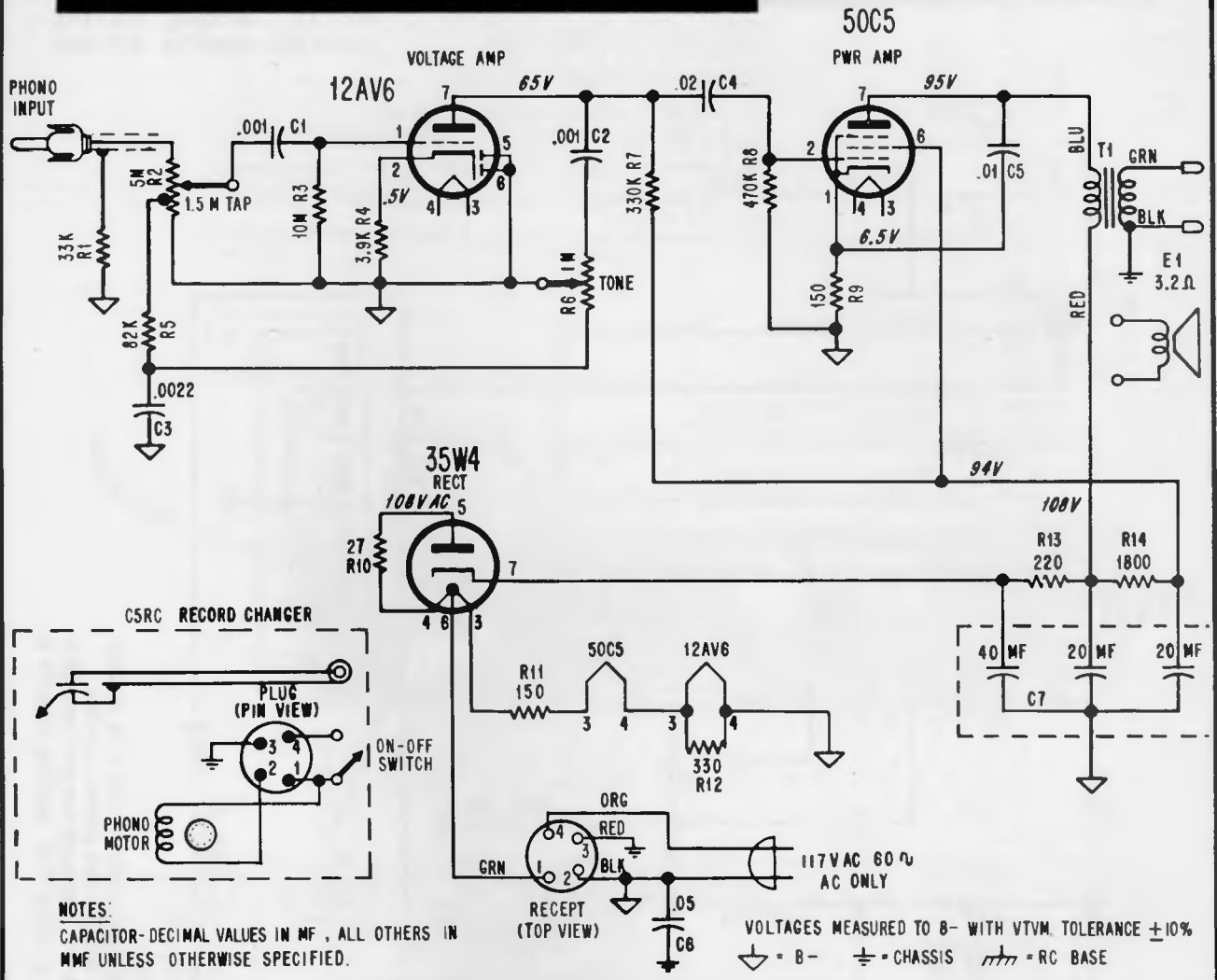

MODELS
26F1 Two Tone Green
26F2 Red and Gray

CHASSIS
HS-491
HS-491

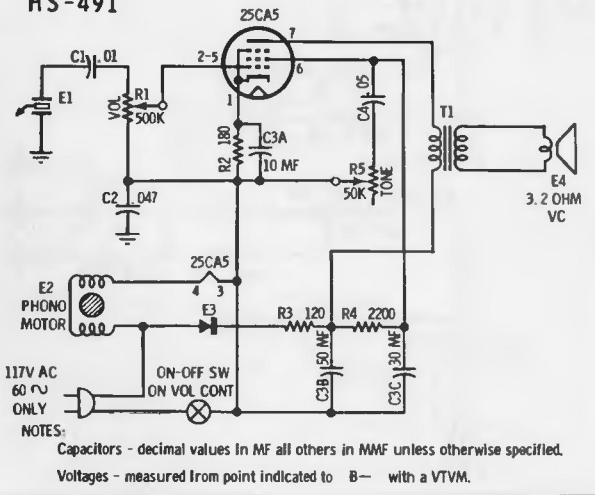
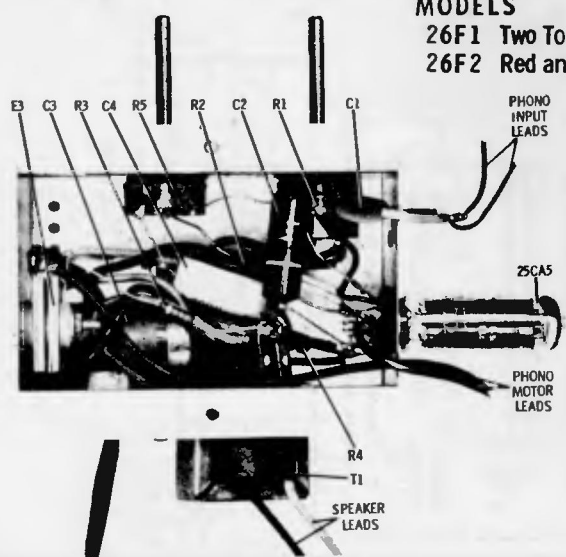

MOTOROLA INC.

MODELS CHASSIS
 56RF1 Red and Gray HS-497
 56RF2 White & Ebony HS-497

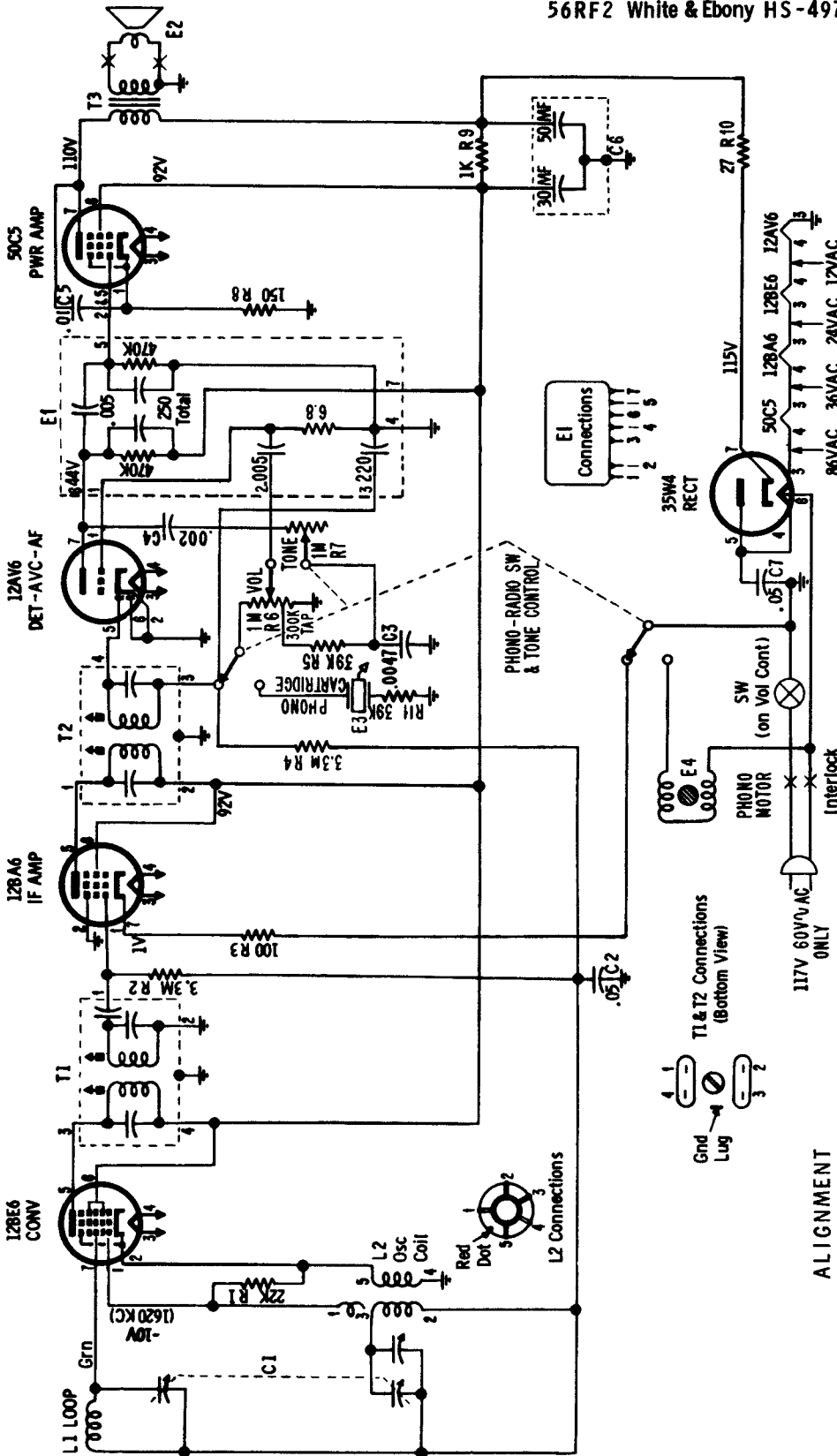

ALIGNMENT

Use an isolation transformer between the power line and the receiver. If not available, connect low side of generator to ground (outer chassis edges) through a .1 mf capacitor. Temporarily connect speaker and antenna leads to receiver. Connect a low range output meter across speaker voice coil and set volume control to maximum and tone control to treble. Attenuate generator output to maintain .40 volts on output meter to prevent overloading.

NOTES:
 Capacitors - Decimal values in MF, all others in MMF unless otherwise specified
 Voltages - Measured from point indicated to ground with a VTVM. No signal input
 input voltage - 117V AC ±10%.
 Tuning Range - 535 to 1620 KC
 IF - 455 KC

STEP	DUMMY ANTENNA	GENERATOR CONNECTION	GENERATOR FREQUENCY (400 cycle mod)	GANG SETTING	ADJUST	REMARKS
IF ALIGNMENT 1.	.1 mf	Grid of conv. (pin 7, 12BE6)	455 Kc	Fully open	1, 2, 3 & 4 (IF cores)	Adjust for maximum. Use insulated screwdriver.
OSC ALIGNMENT 2.	.1 mf	Grid of conv. (pin 7, 12BE6)	1620 Kc	Fully open	5 (Osc)	Adjust for maximum.



MODELS

- 56B1A
- 56B1AU
- 56L1A
- 56L1AU
- 56L2A
- 56L2AU
- 56L3A
- 56L3AU
- 56L4A
- 56L4AU
- 56M1A
- 56M1AU
- 56M2A
- 56M2AU
- 56M3A
- 56M3AU

- Brown
- Brown
- Gray
- Gray
- Red
- Red
- Pink
- Pink
- Blue
- Blue
- White
- White
- Blue & White
- Blue & White
- Tan & White
- Tan & White

CHASSIS

- HS-512
- HS-512A
- HS-513
- HS-513A
- HS-513
- HS-513A
- HS-513
- HS-513A
- HS-513
- HS-513A
- HS-514
- HS-514A
- HS-514
- HS-514A
- HS-514
- HS-514A

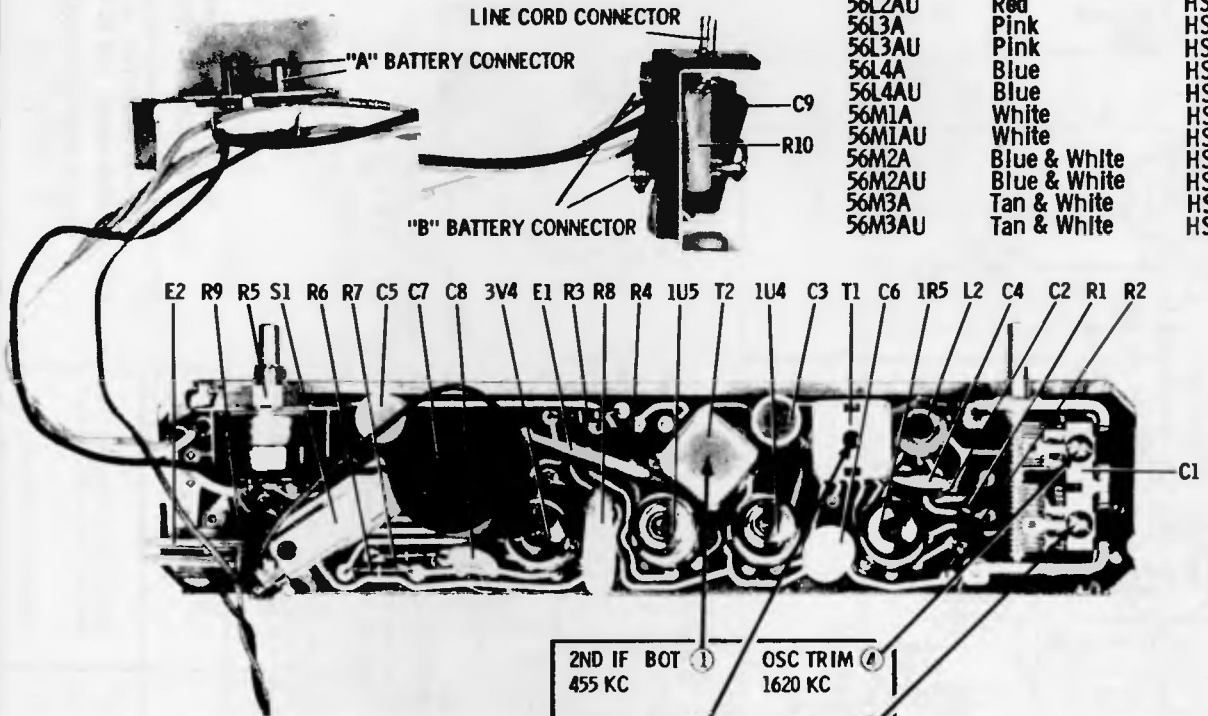

ALIGNMENT ADJUSTMENTS AND PARTS LOCATION

2ND IF BOT 455 KC	1	OSC TRIM 1620 KC	4
1ST IF TOP 455 KC BOT	2	ANT TRIM 1400 KC	5
	3		

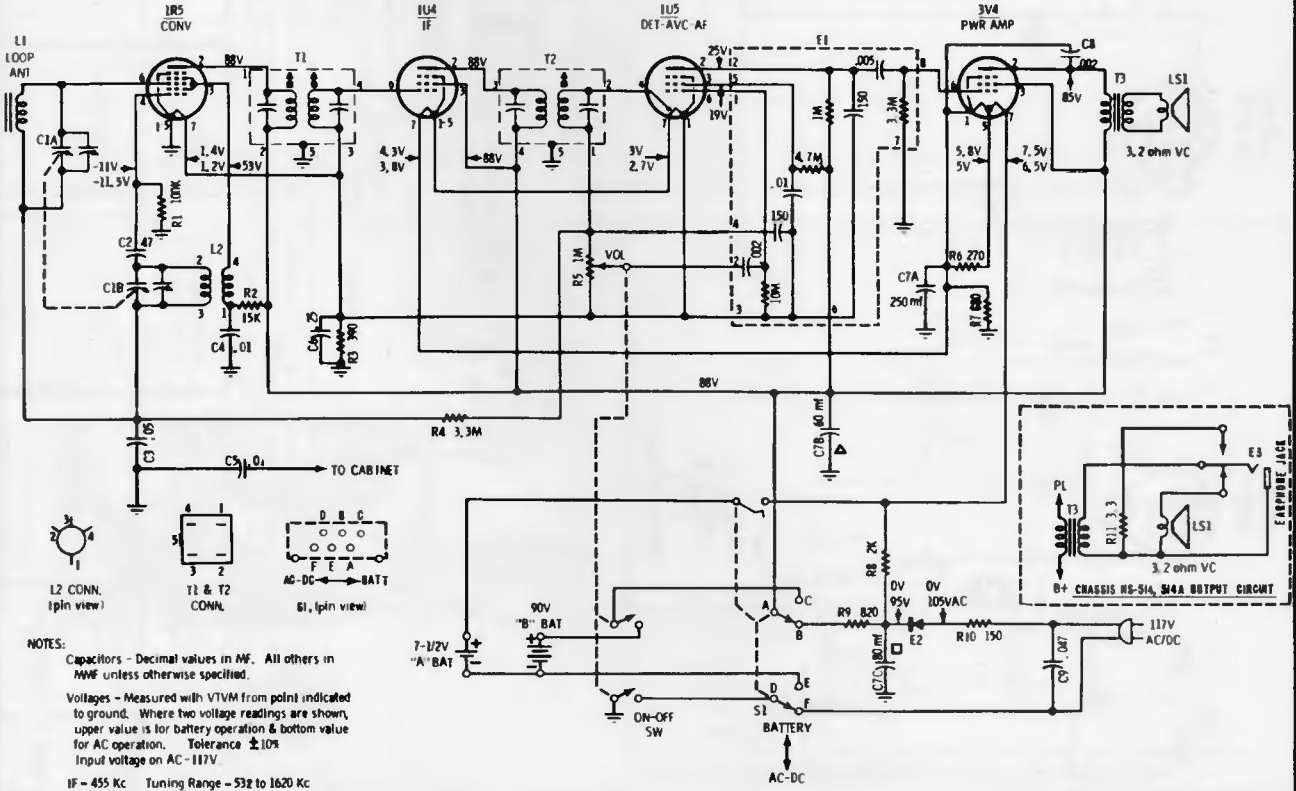

NOTES:
 Capacitors - Decimal values in μ F. All others in $m\mu$ F unless otherwise specified.
 Voltages - Measured with VTVM from point indicated to ground. Where two voltage readings are shown, upper value is for battery operation & bottom value for AC operation. Tolerance $\pm 10\%$.
 Input voltage on AC - 117V.
 IF - 455 Kc Tuning Range - 532 to 1620 Kc

MOTOROLA

CHASSIS
HS-515

MODELS
66L1 CHARCOAL
66L2 SUNTAN

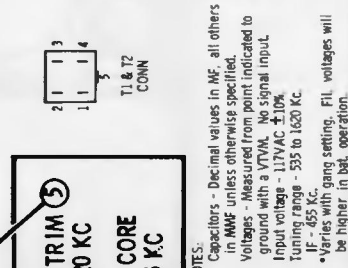
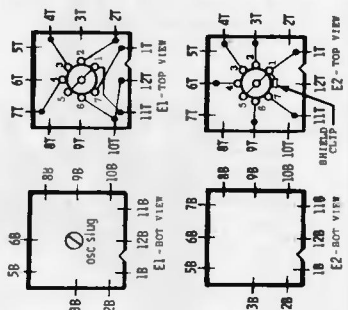
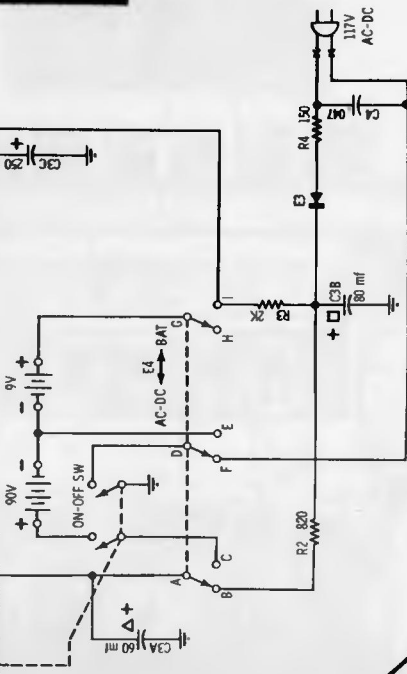
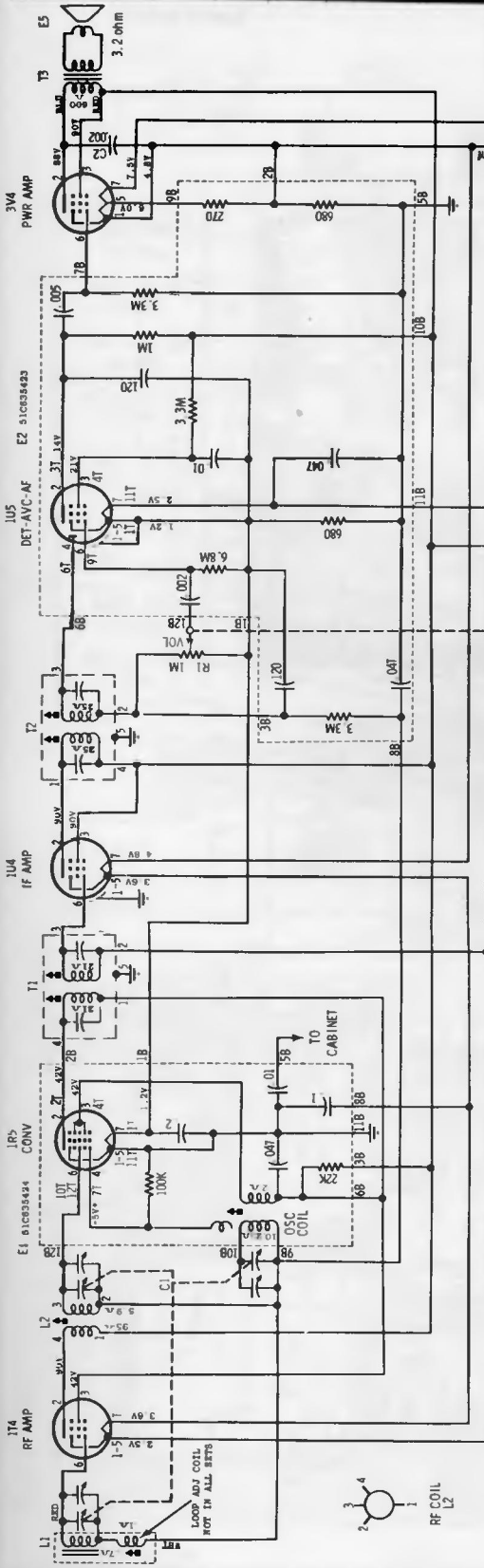

- ① ANT CORE 600 KC
- ② 1ST IF 455 KC
- ③ 2ND IF 455 KC
- ④ RF CORE 600 KC
- ⑤ ANT TRIM 1400 KC
- ⑥ RF TRIM 1400 KC
- ⑦ OSC TRIM 1620 KC
- ⑧ OSC CORE 535 KC

NOTES:
Capacitors - Decimal values in MF; all others in MMF unless otherwise specified.
Voltages - Measured from point indicated to ground with a VTVM. No signal input.
Input voltage - 117VAC ±10%
Tuning range - 535 to 1620 KC.
IF - 455 KC.
*Varies with gang setting. Fil. voltages will be higher in bat. operation.

VOLUME R-16, MOST-OFTEN-NEEDED 1956 RADIO SERVICING INFORMATION

MOTOROLA INC.

MODEL
CTA5

Automotive type superheterodyne receiver designed for custom installation in the 1955 CHEVROLET cars. This radio operates from a 12 volt battery source.

DUMMY ANTENNA

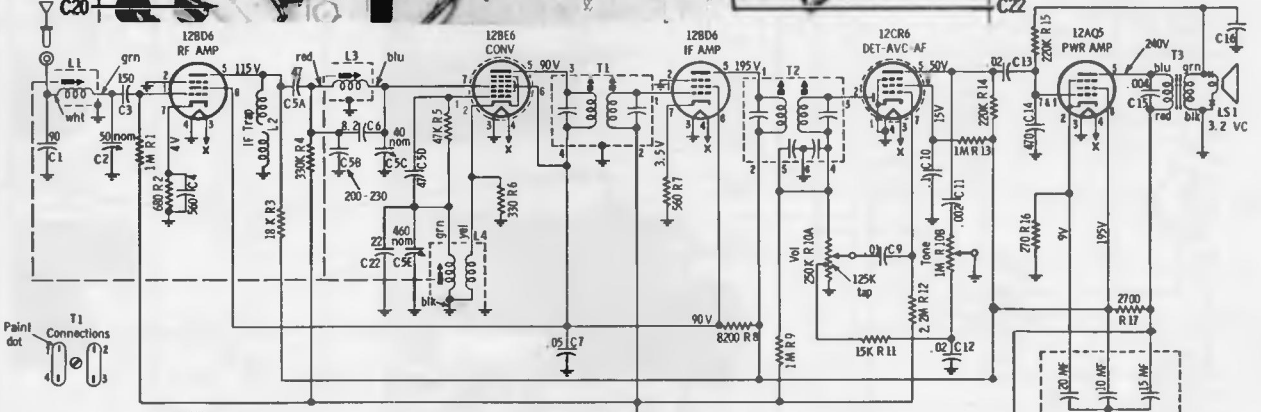
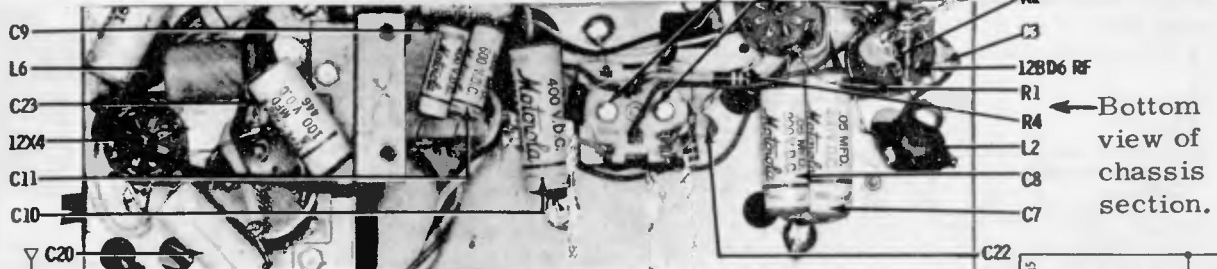
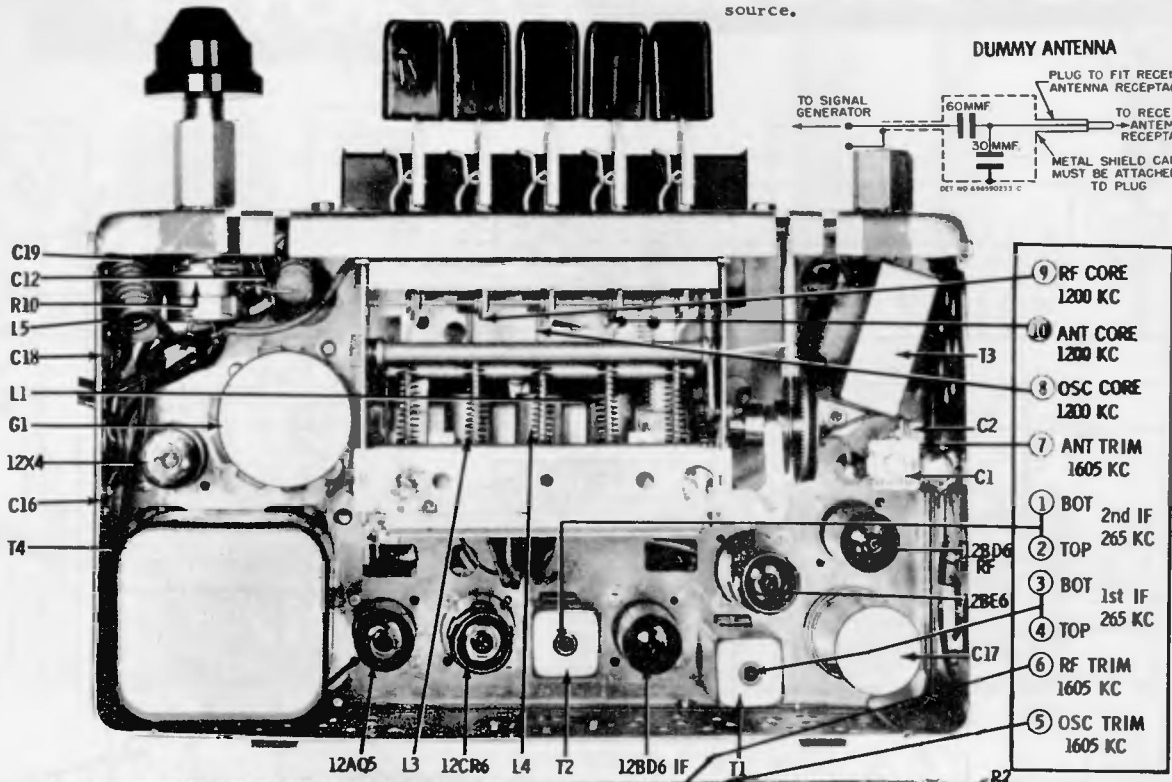
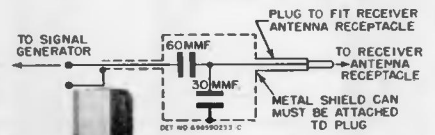

NOTES:
 CAPACITORS - decimal values in mμ, all others in μ unless otherwise specified.
 VOLTAGES - measured from point indicated to chassis with a VTVM. No signal input.
 INPUT VOLTAGE 14 VDC. ± 10%
 TUNING RANGE - 540 - 1605 Kc.
 IF - 265 Kc.

Connect to accessory junction block terminal marked "RADIO" install 9 amp fuse.

ON-OFF SW (on vol cont)

CSA, B, C, D, E CONNECTIONS

MOTOROLA

AMERICAN MOTORS

8990378

MOTOROLA 6MA

TYPE - Automotive type superheterodyne receiver custom designed for installation in the 1956 Hudson Wasp and Hornet and the 1956 Nash Statesman and Ambassador.

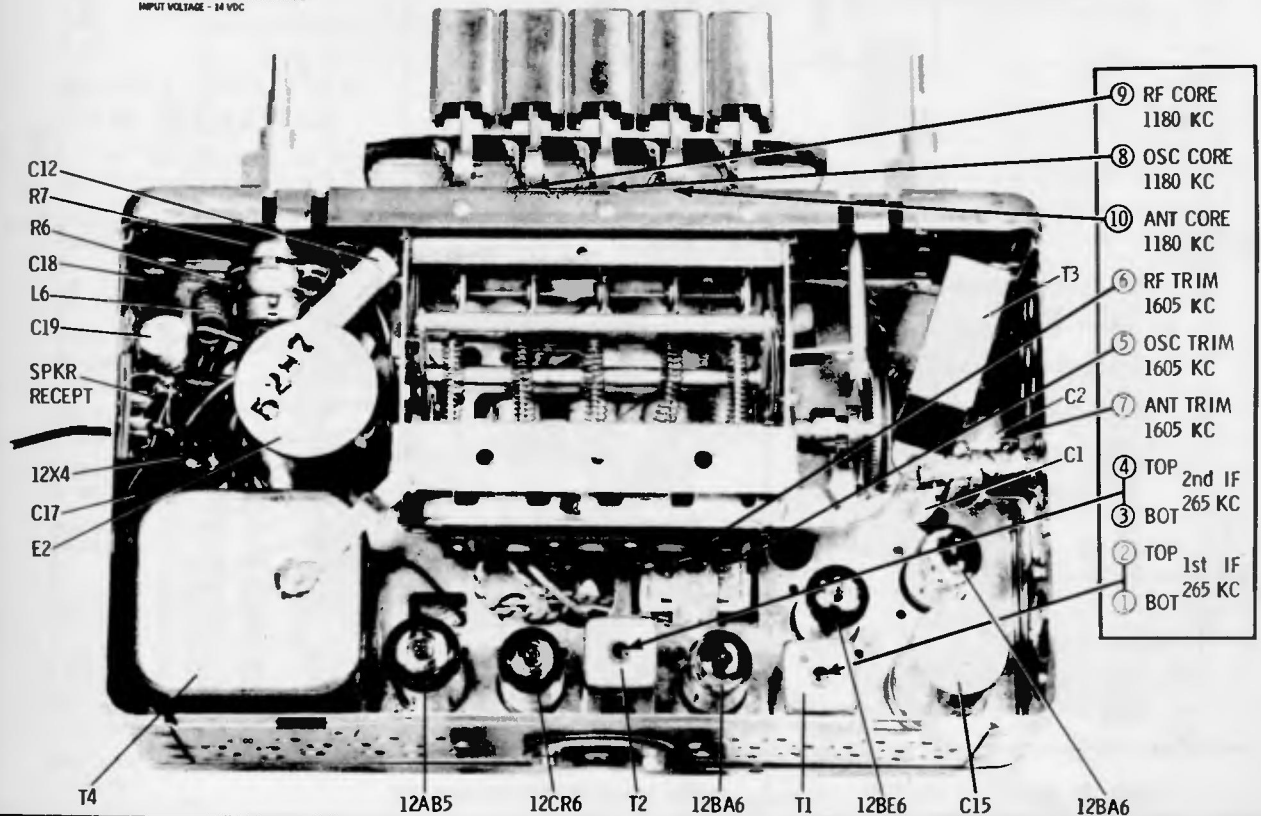
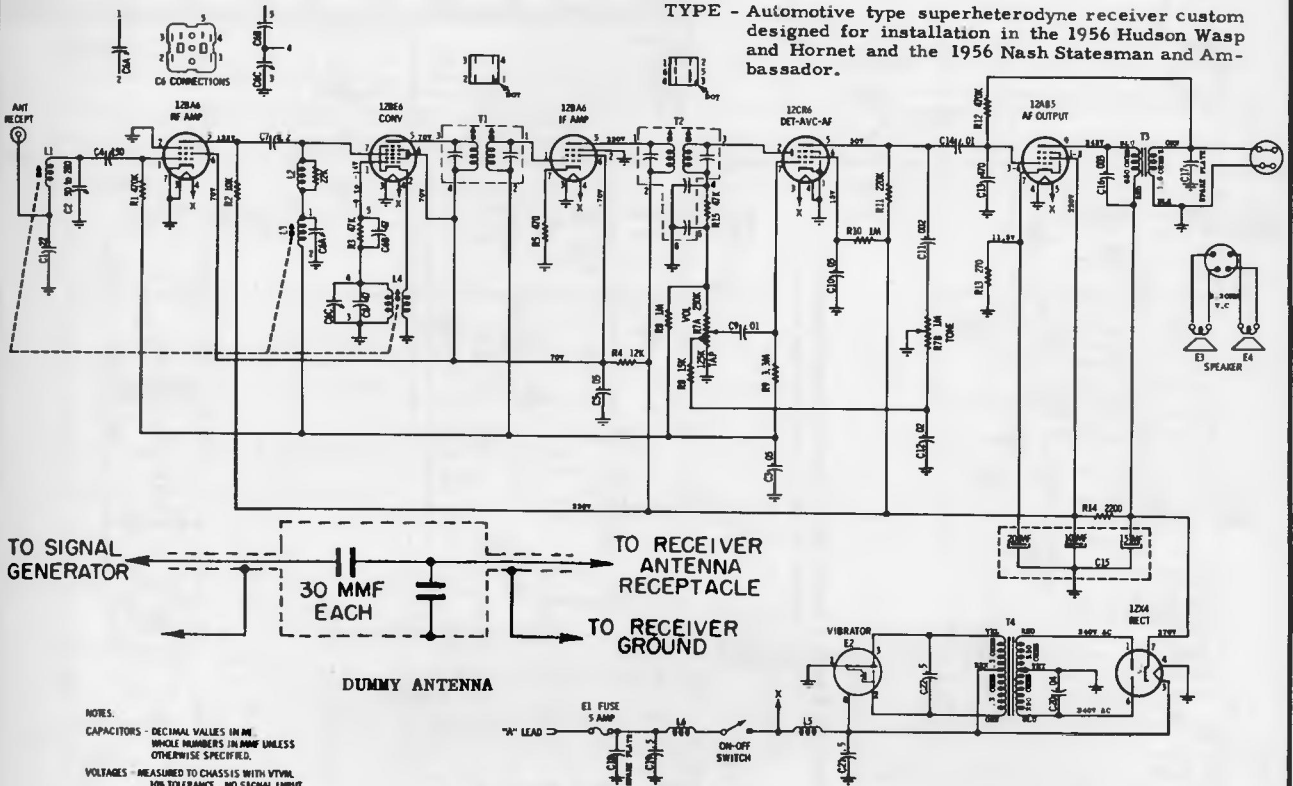

MOTOROLA

This material is exact for Models 5M and 5M-12. Circuits of Models 6M and 6M-12 are correspondingly similar.

**MODELS
5M
5M-12**

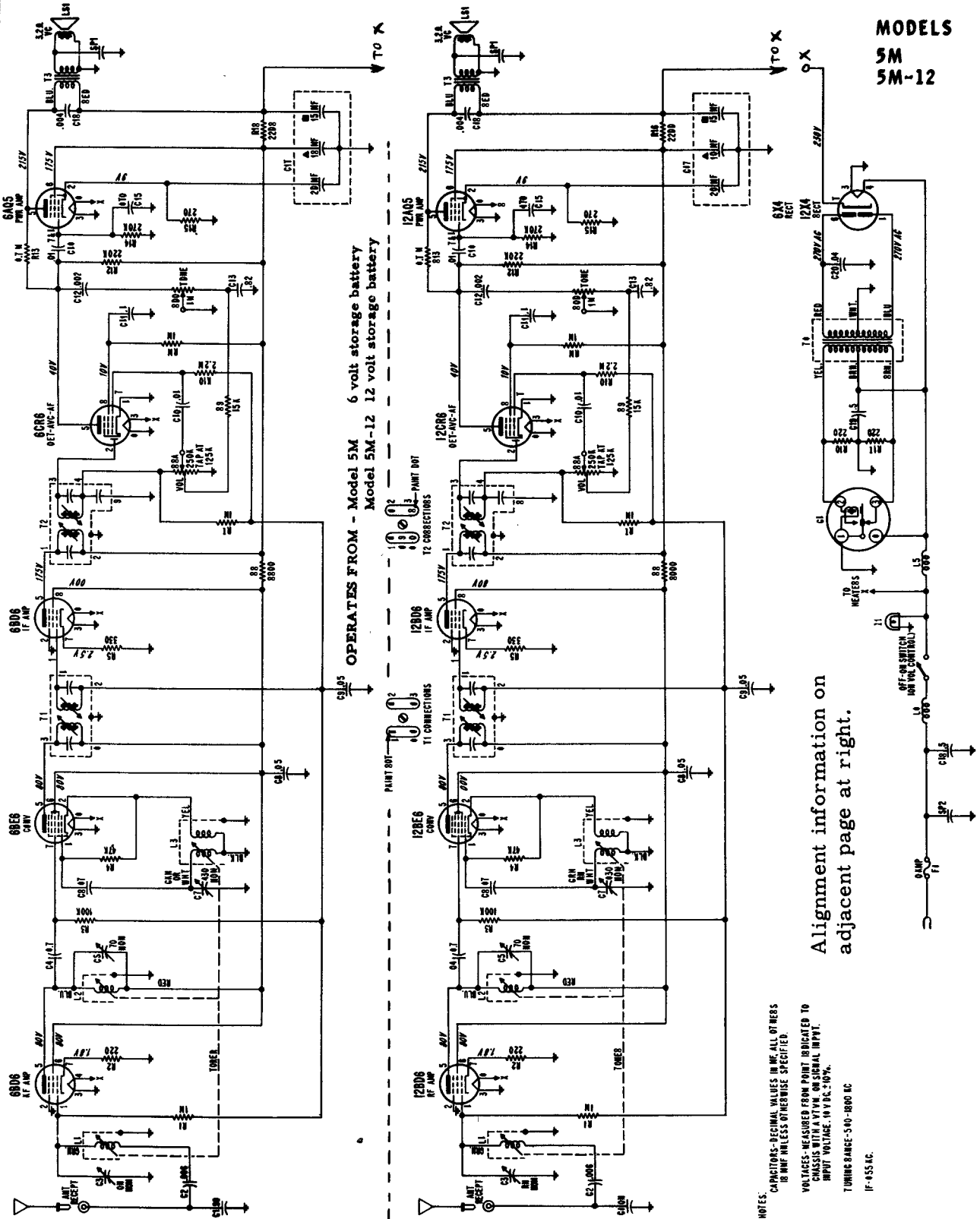

MODEL 5M SCHEMATIC DIAGRAM

MODEL 5M-12 SCHEMATIC DIAGRAM

Alignment information on adjacent page at right.

NOTES:
CAPACITORS-DECIMAL VALUES IN MF, ALL OF REBS IS IN PF UNLESS OTHERWISE SPECIFIED.
VOLTAGES-MEASURED FROM POINT INDICATED TO CHASSIS WITH A VTVM, ON SIGNAL INPUT.
INPUT VOLTAGE: 100 VDC ±10%.
TUNING RANGE: 540-800 DC IF-455 KC.

Motorola

MODELS
5M
5M-12

Alignment Information
(Circuit diagrams on adjacent page at left.)

Connect output meter across speaker voice coil. Set tone to high and volume to maximum. Attenuate generator to maintain 1.79 volts (1 watt) on output meter to prevent overloading of receiver.

STEP	DUMMY ANTENNA	GENERATOR CONNECTION	GENERATOR FREQUENCY	TUNER SET TO	ADJUST (in order shown)	REMARKS
IF ALIGNMENT						
1.	.1 mf	6BE6 grid (pin 7)	455 Kc	Hi end stop	1, 2, 3, 4	Peak for maximum.
RF ALIGNMENT						
NOTE: Back tuner cores completely out of coils before proceeding.						
2.	See Fig.	Ant. recept	1610 Kc	Hi end stop	5, 6, 7	Peak for maximum
3.	See Fig.	Ant. recept	1400 Kc	13/64" from hi end stop	8, 9, 10	Peak for maximum using alignment tools shown in Figure.
4.	Repeat steps 2 and 3 until no further increase.					
ANTENNA TRIMMER ADJUSTMENT						
5.				Weak station around 1400 Kc	7	With radio in car, peak ant trimmer.

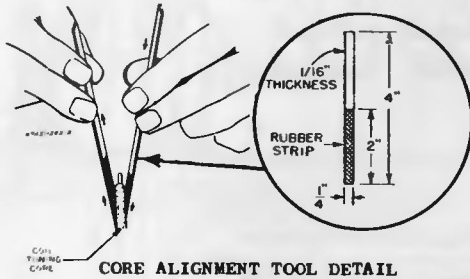

CORE ALIGNMENT TOOL DETAIL

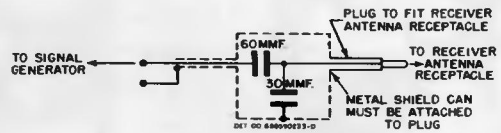

DUMM ANTENNA DETAIL

POINTER REPLACEMENT AND CALIBRATION

Set tuner to high end stop. Place pointer on pointer slide and set to coincide with calibration dot furthest right. Crimp and cement pointer in place.

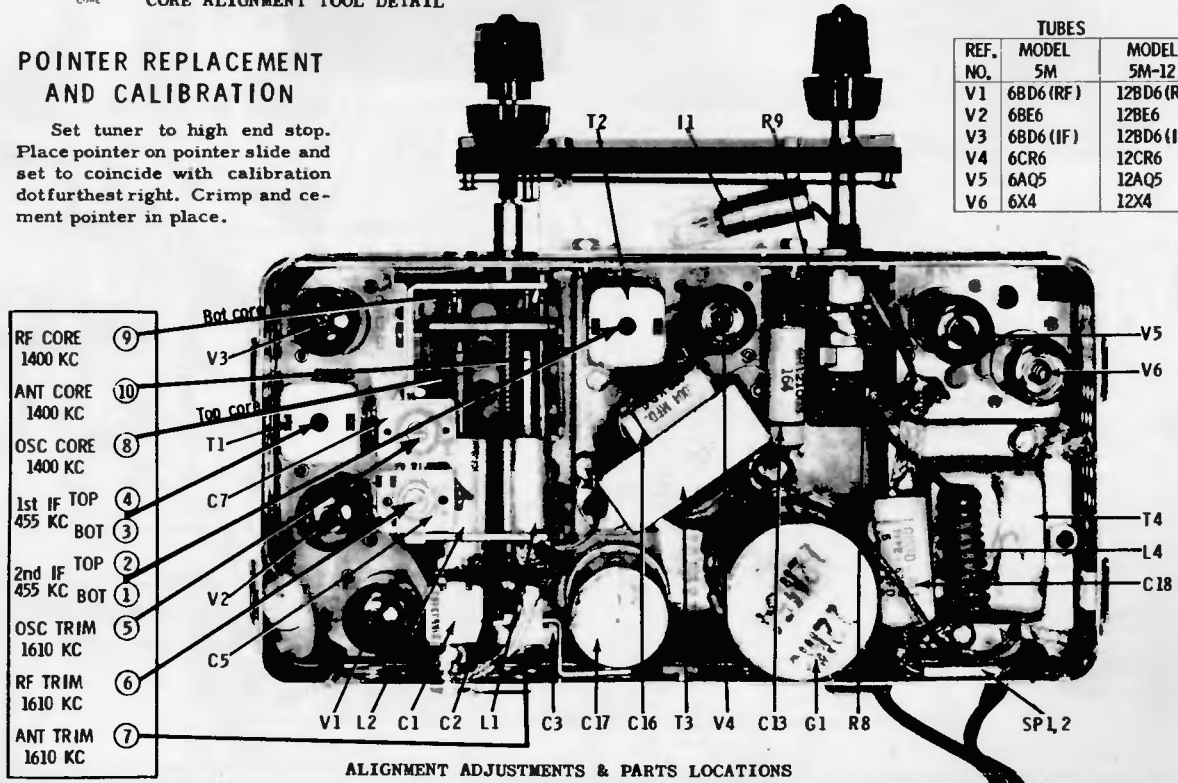

ALIGNMENT ADJUSTMENTS & PARTS LOCATIONS

VOLUME R-16, MOST-OFTEN-NEEDED 1956 RADIO SERVICING INFORMATION

MOTOROLA

MODEL
MOTOROLA HN5AC-8
HUDSON 4389027

ALIGNMENT

Connect an output meter across speaker voice coil. Set volume and tone control to maximum. Attenuate signal generator output to maintain 1.79 volts (1 watt) on output meter to prevent overloading.

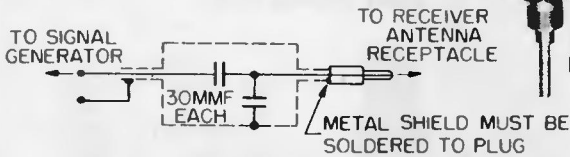
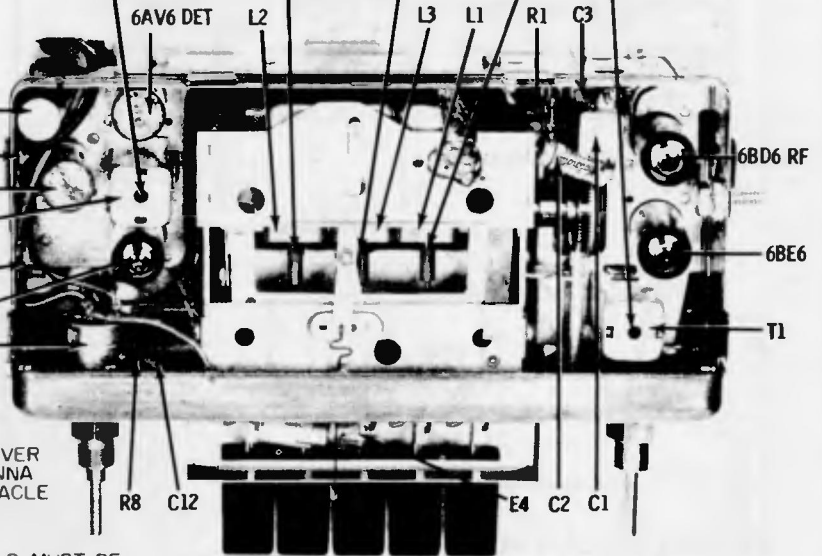
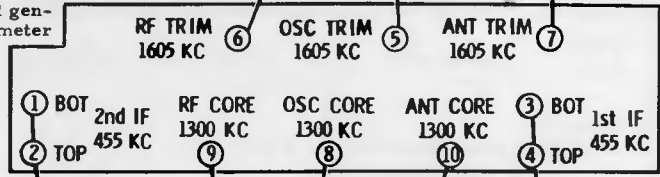
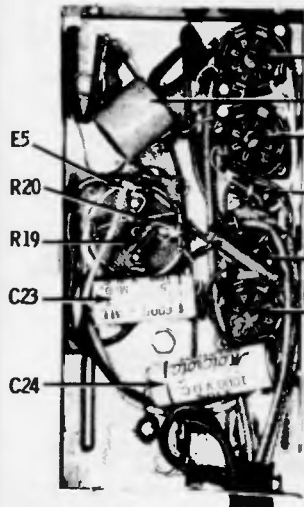
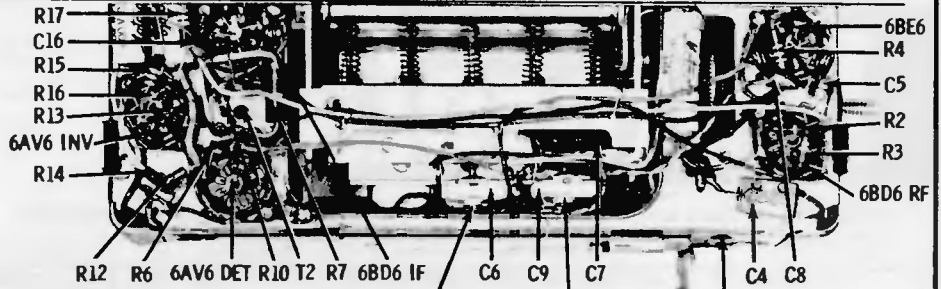

PARTS LOCATIONS & ALIGNMENT ADJUSTMENTS

DUMMY ANTENNA

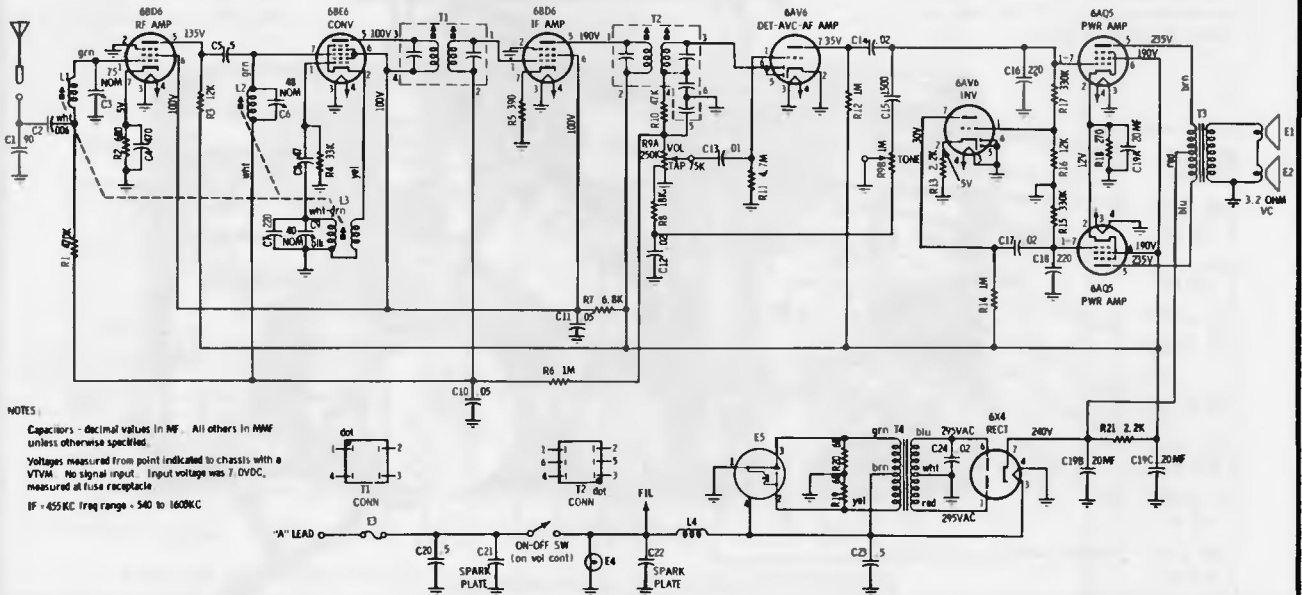

NOTES:
Capacitors - decimal values in MF. All others in MMF unless otherwise specified.
Voltages measured from point indicated to chassis with a VTVM. No signal input. Input voltage was 7 DVDC, measured at fuse receptacle.
IF - 455 KC freq range - 540 to 1620 KC.

MOTOROLA Auto Radio Model CTM6 (for 1956 and 1955 Chevrolet)

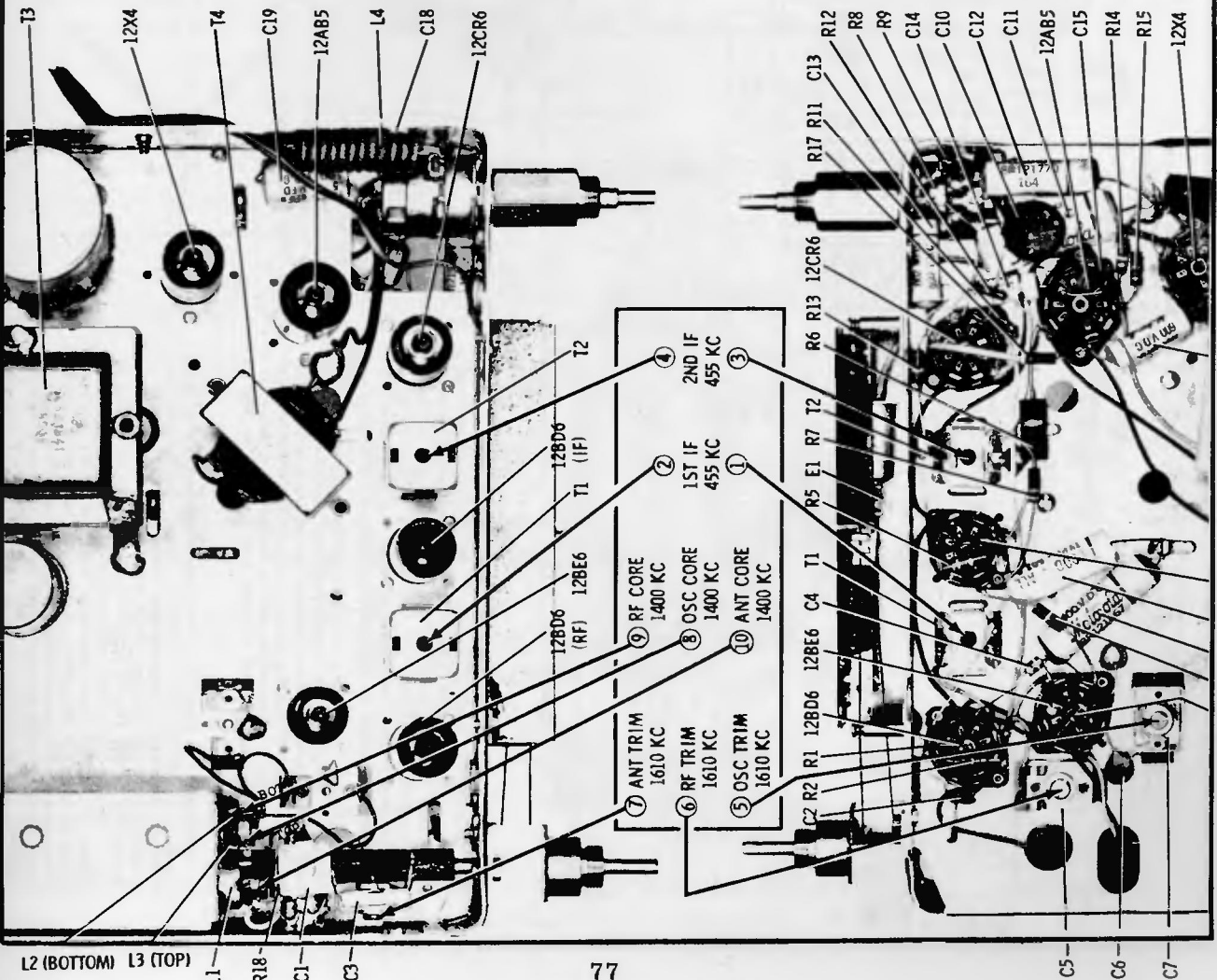
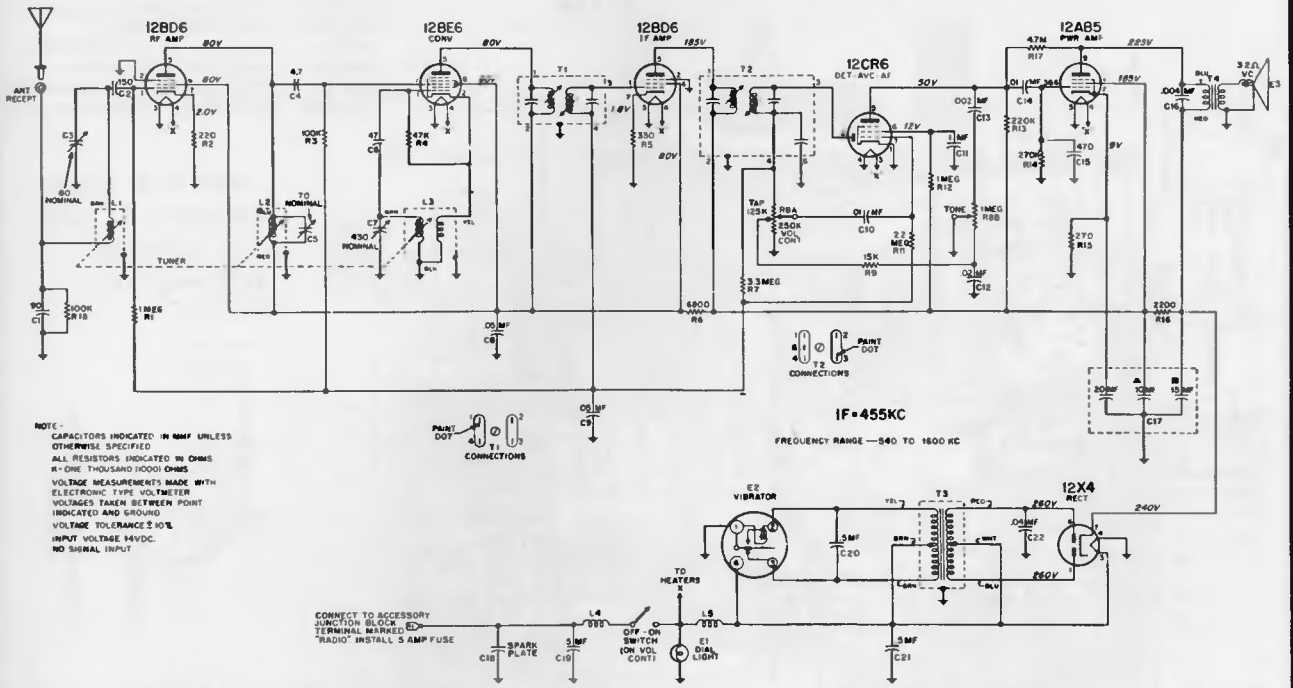

L2 (BOTTOM) L3 (TOP)

MOTOROLA

**MODEL
6TAS8**

- KBKS6 - 1956 Buick
- KBKS5 - 1955 and 1954 Buick
- KCTS6 - 1956 and 1955 Chevrolet
- KOES6 - 1956 Oldsmobile
- KOES5 - 1955 and 1954 Oldsmobile
- KPCS6 - 1956 and 1955 Pontiac
- KSR56 - 1956 Studebaker - all models
- KSR56H - 1956 Studebaker - Hawk only

See next page adjacent at right for alignment information.

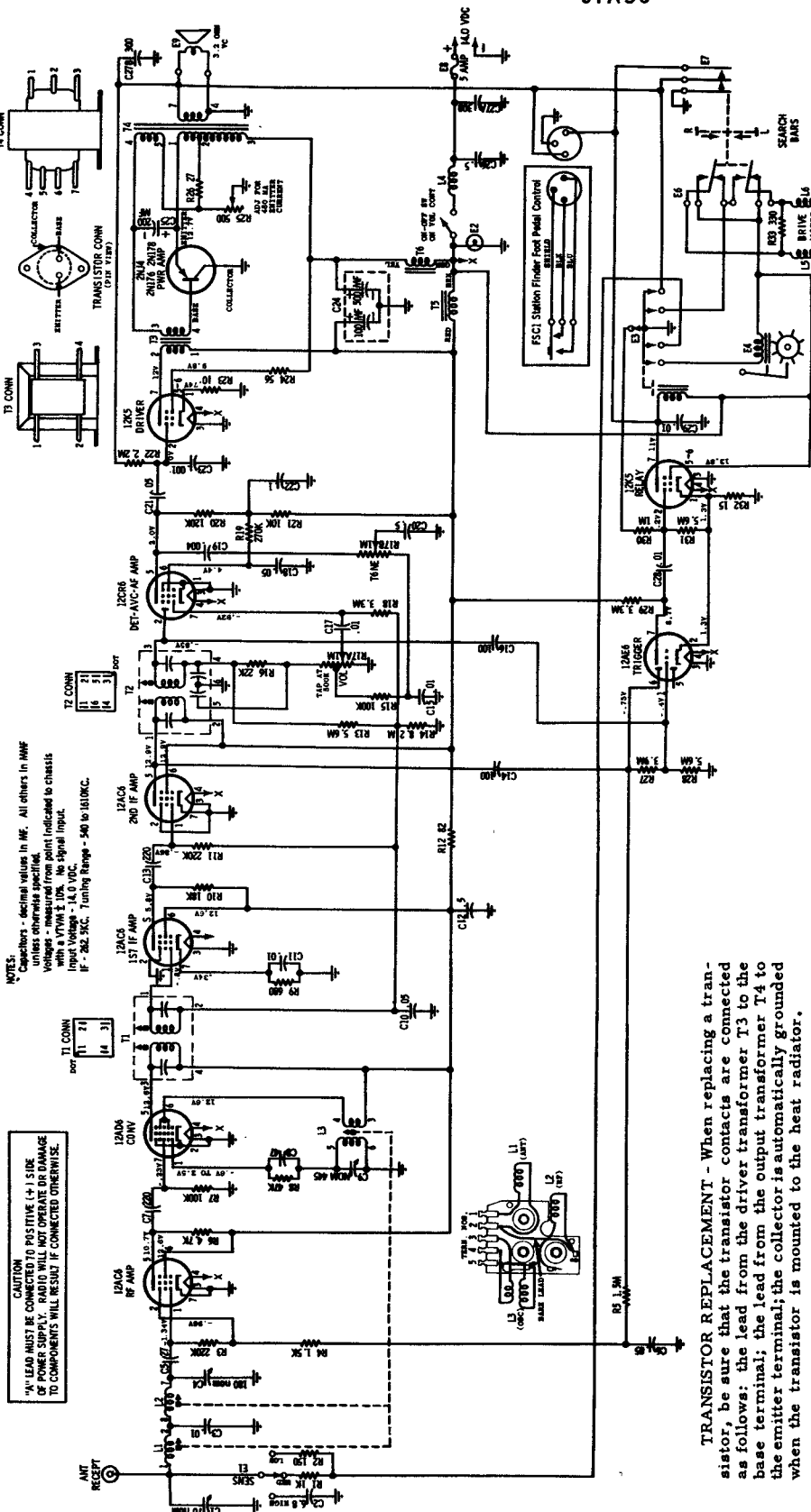
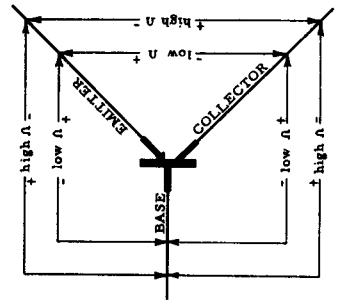
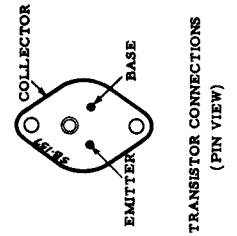

NOTES:
 Capacitors - decimal values in MF. All others in MMF unless otherwise specified.
 Voltages - measured from point indicated to chassis with a VTVM $\pm 10\%$. No signal input.
 Input Voltage - 14.0 VDC.
 IF - 262.5 KC. Tuning Range - 540 to 1610 KC.

CAUTION
 "A" LEAD MUST BE CONNECTED TO POSITIVE (+) SIDE OF POWER SUPPLY. RADIO WILL NOT OPERATE OR DAMAGE TO COMPONENTS WILL RESULT IF CONNECTED OTHERWISE.

TRANSISTOR REPLACEMENT - When replacing a transistor, be sure that the transistor contacts are connected as follows: the lead from the driver transformer T3 to the base terminal; the lead from the output transformer T4 to the emitter terminal; the collector is automatically grounded when the transistor is mounted to the heat radiator.

EMITTER CURRENT ADJUSTMENT - To adjust the emitter current, insert a milliammeter in series with the emitter electrode. This can be done by unplugging the emitter lead and connecting the positive side of the milliammeter to this lead, and the negative side to transistor emitter terminal. Adjust the variable 500 ohm resistor R-25 for 480 ma current.

TRANSISTOR CHECK - The transistor used in this radio can be expected to give unusually long trouble free life, however, transistor checks may be made as follows: A rough check of transistor condition can be made with an ohmmeter. This check, primarily measures the ability of the transistor to conduct current in one direction, and to resist current flow in the opposite direction. The resistance in the conduction direction is very low in relation to the resistance in the non-conduction direction. This check is made by connecting the ohmmeter heads as shown in illustration.

MOTOROLA Auto Radio Model 6TAS8 (Continued)

Alignment Information

(Continued from preceding page adjacent at left.)

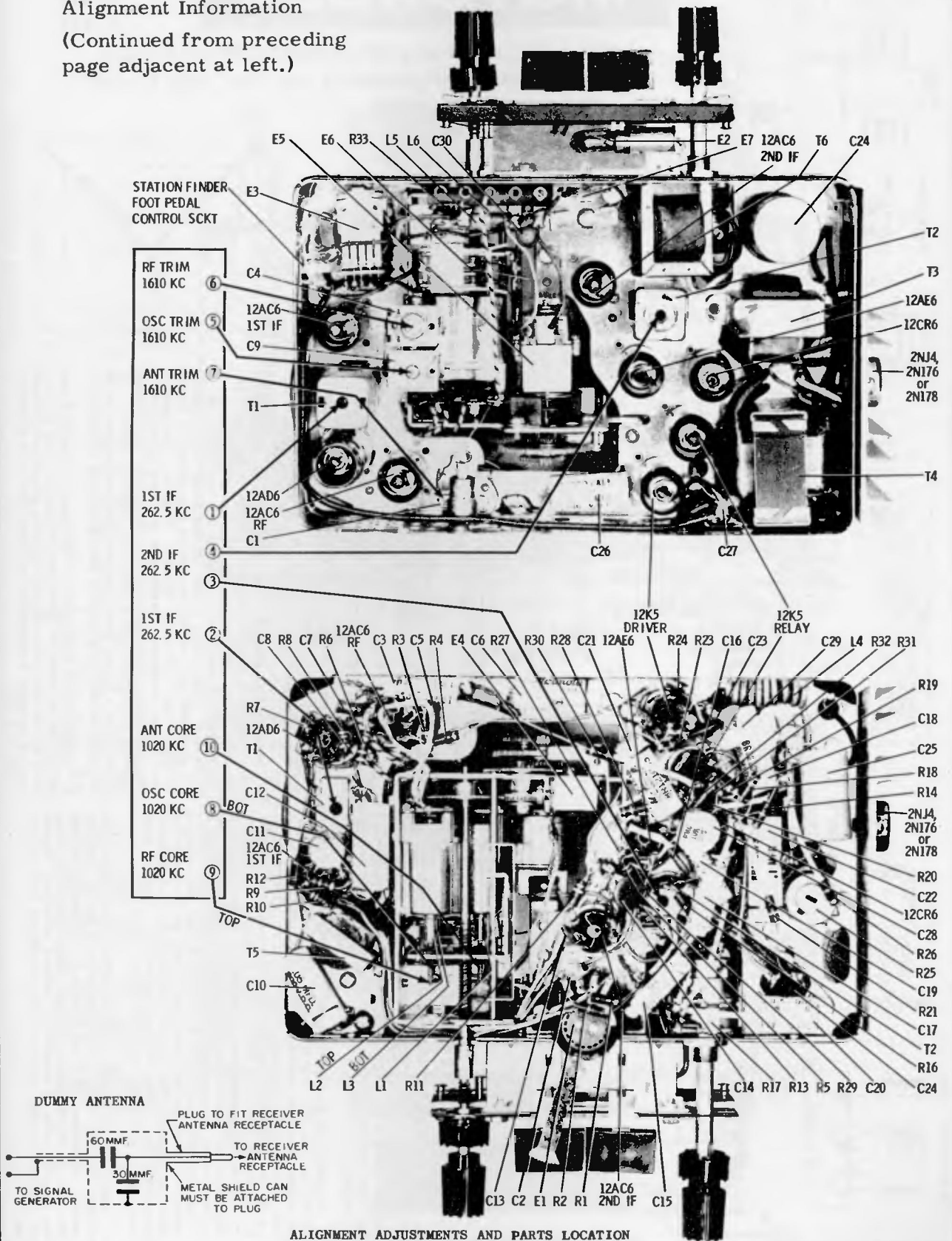

MOTOROLA

AUTO RADIO
MODEL
CTA6T

For installation in 1956 and 1955 Chevrolet cars.
(For alignment adjustments see next page at right.)

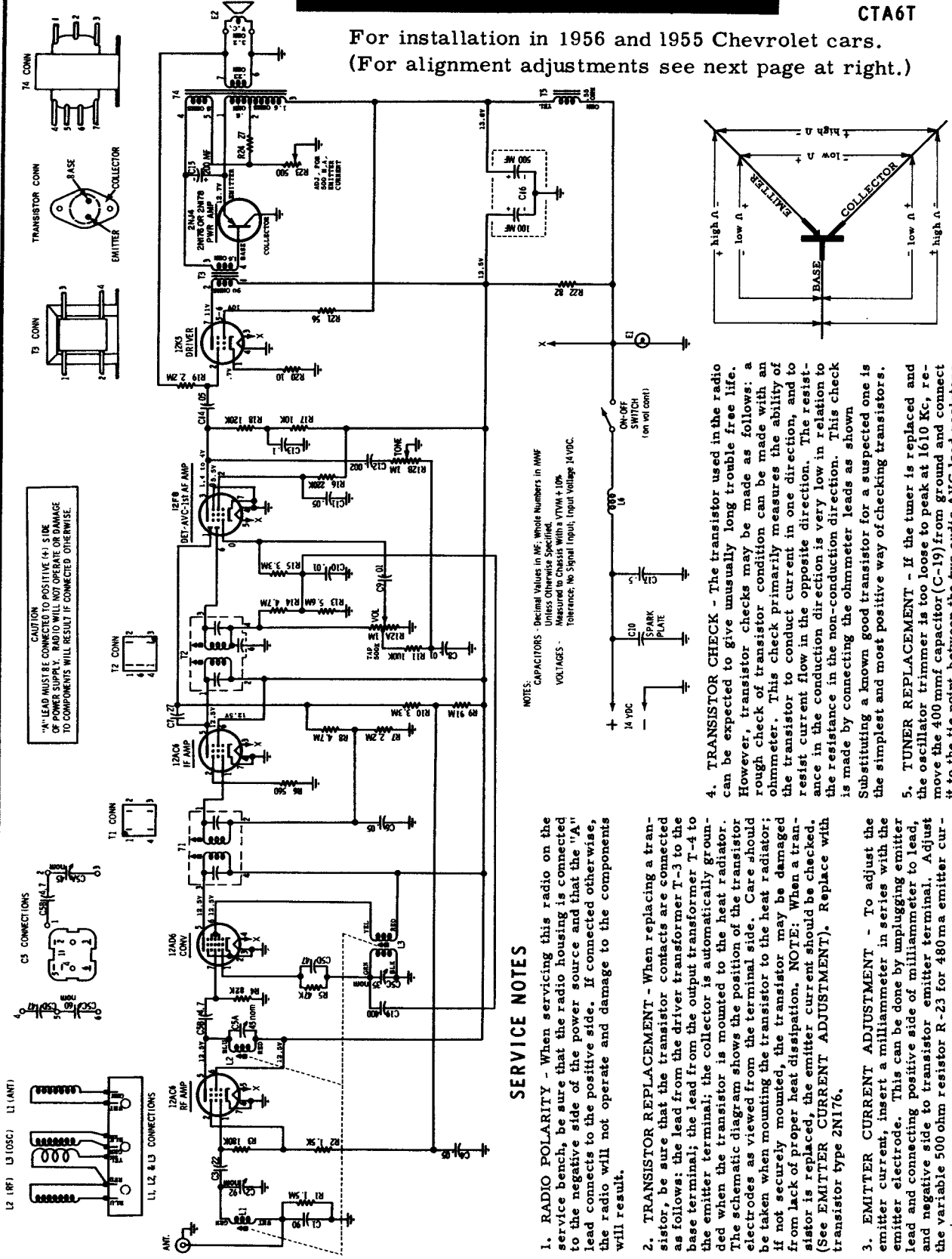

SERVICE NOTES

- RADIO POLARITY** - When servicing this radio on the service bench, be sure that the radio housing is connected to the negative side of the power source and that the "A" lead connects to the positive side. If connected otherwise, the radio will not operate and damage to the components will result.
- TRANSISTOR REPLACEMENT** - When replacing a transistor, be sure that the transistor contacts are connected as follows: the lead from the driver transformer T-3 to the base terminal; the lead from the output transformer T-4 to the emitter terminal; the collector is automatically grounded when the transistor is mounted to the heat radiator. The schematic diagram shows the position of the transistor electrodes as viewed from the terminal side. Care should be taken when mounting the transistor to the heat radiator; if not securely mounted, the transistor may be damaged from lack of proper heat dissipation. **NOTE:** When a transistor is replaced, the emitter current should be checked. (See **EMITTER CURRENT ADJUSTMENT**). Replace with transistor type 2N176.
- EMITTER CURRENT ADJUSTMENT** - To adjust the emitter current, insert a milliammeter in series with the emitter electrode. This can be done by unplugging emitter lead and connecting positive side of milliammeter to lead, and negative side to transistor emitter terminal. Adjust the variable 500 ohm resistor R-23 for 480 ma emitter current.
- TRANSISTOR CHECK** - The transistor used in the radio can be expected to give unusually long trouble free life. However, transistor checks may be made as follows: a rough check of transistor condition can be made with an ohmmeter. This check primarily measures the ability of the transistor to conduct current in one direction, and to resist current flow in the opposite direction. The resistance in the conduction direction is very low in relation to the resistance in the non-conduction direction. This check is made by connecting the ohmmeter leads as shown. Substituting a known good transistor for a suspected one is the simplest and most positive way of checking transistors.
- TUNER REPLACEMENT** - If the tuner is replaced and the oscillator trimmer is too loose to peak at 1610 KC, remove the 400 mmf capacitor (C-19) from ground and connect it to the tie point between the two audio AVC load resistors R-13 and R-14.

TRANSISTOR RESISTANCE CHECK

MOTOROLA Auto Radio Model CTA6T

Alignment Adjustments

(Continued from preceding page adjacent at left.)

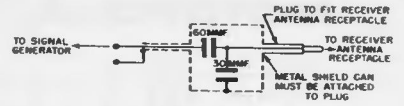

DUMMY ANTENNA

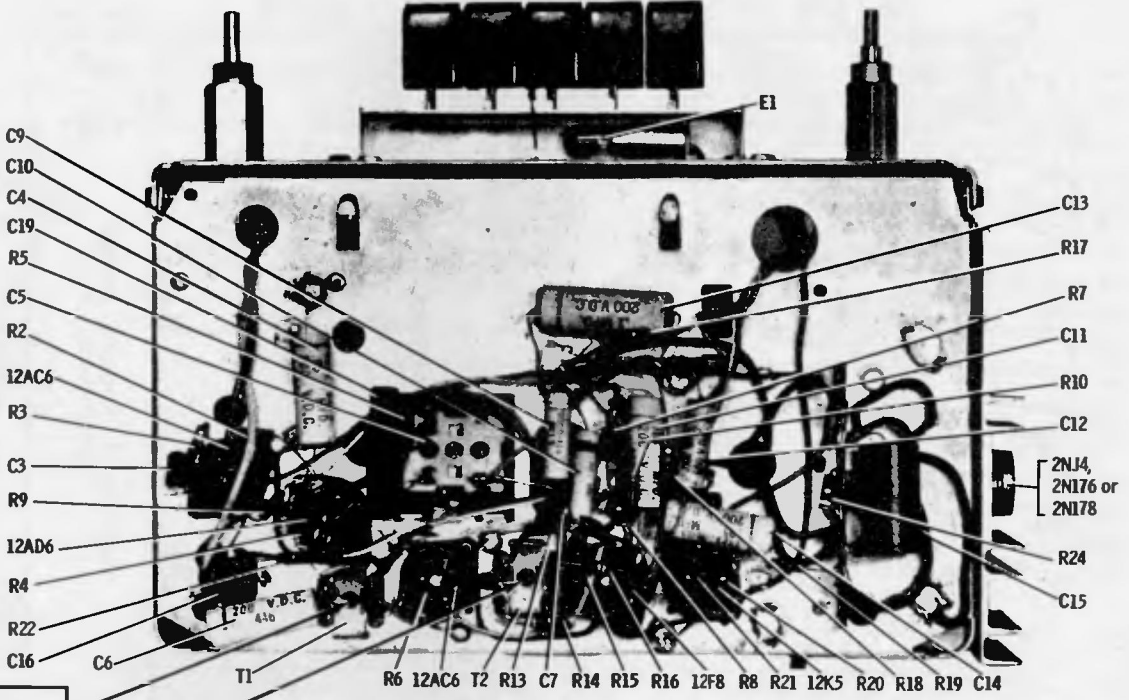

- 1ST IF 455 KC ①
- 2ND IF 455 KC ③
- 1ST IF 455 KC ②
- 2ND IF 455 KC ④
- RF TRIM 1610 KC ⑥
- OSC TRIM 1610 KC ⑤
- ANT TRIM 1610 KC ⑦
- RF CORE 1200 KC ⑨
- OSC CORE 1200 KC ⑧
- ANT CORE 1200 KC ⑩

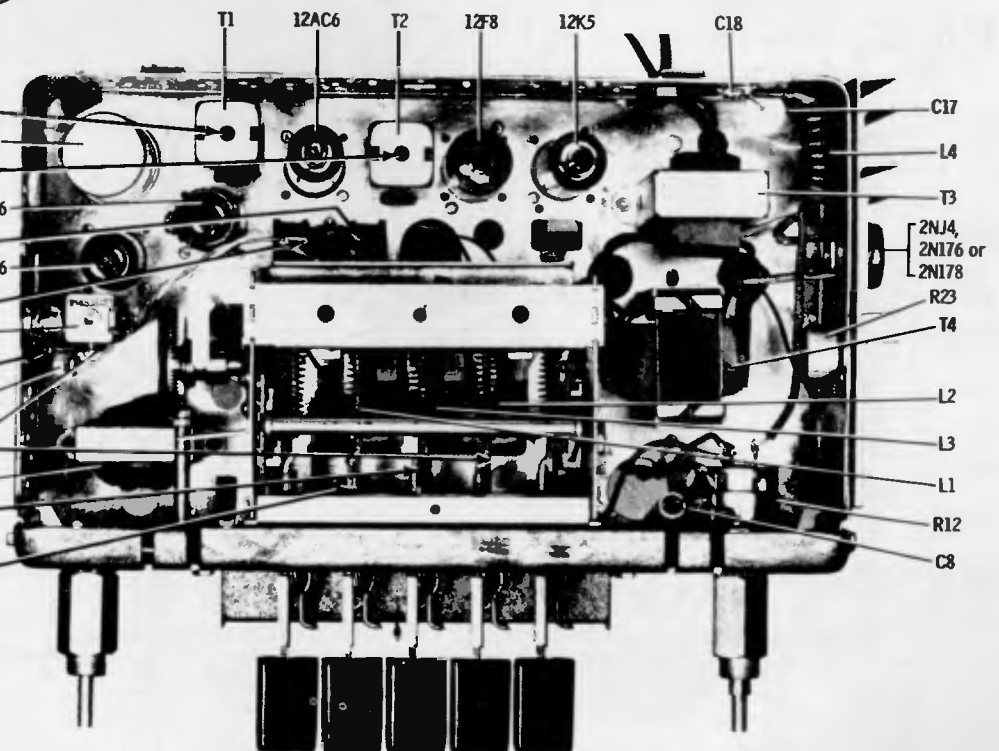

ALIGNMENT ADJUSTMENTS AND PARTS LOCATION

VOLUME R-16, MOST-OFTEN-NEEDED 1956 RADIO SERVICING INFORMATION

MOTOROLA Auto Radio Models 396 and 396-12 (Continued (Continued))

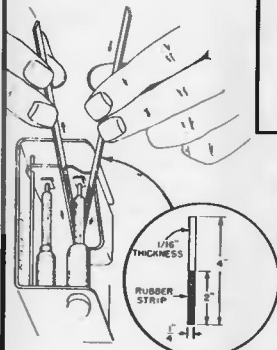
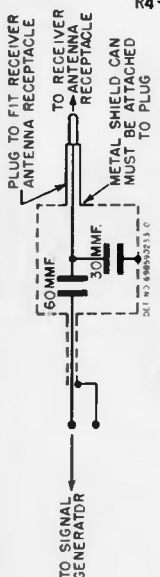
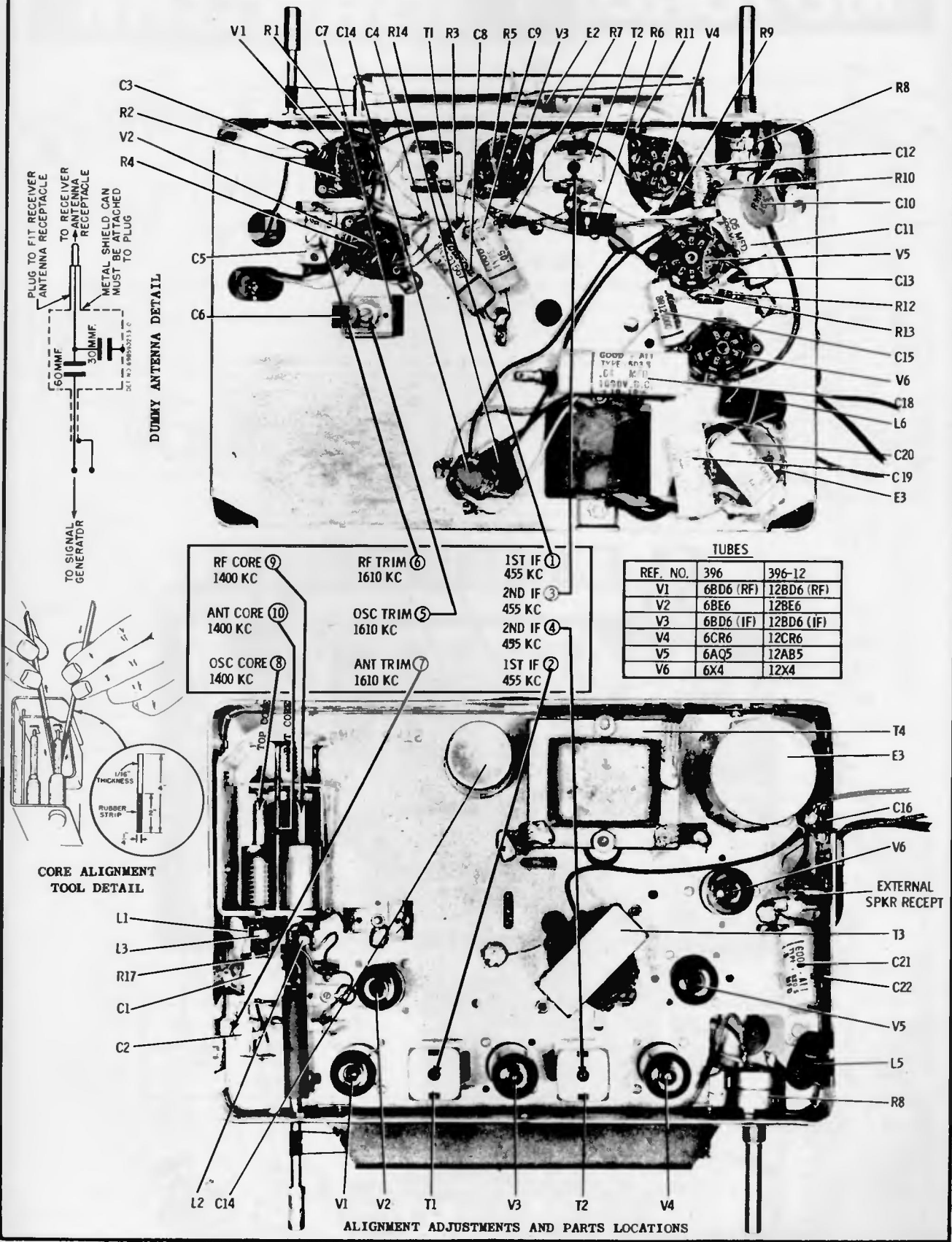

- RF CORE ⑨
1400 KC
- ANT CORE ⑩
1400 KC
- OSC CORE ⑧
1400 KC
- RF TRIM ⑥
1610 KC
- OSC TRIM ⑤
1610 KC
- ANT TRIM ⑦
1610 KC
- 1ST IF ①
455 KC
- 2ND IF ③
455 KC
- 2ND IF ④
455 KC
- 1ST IF ②
455 KC

TUBES

REF. NO.	396	396-12
V1	6BD6 (RF)	12BD6 (RF)
V2	6BE6	12BE6
V3	6BD6 (IF)	12BD6 (IF)
V4	6CR6	12CR6
V5	6AQ5	12AB5
V6	6X4	12X4

- L1
- L3
- R17
- C1
- C2

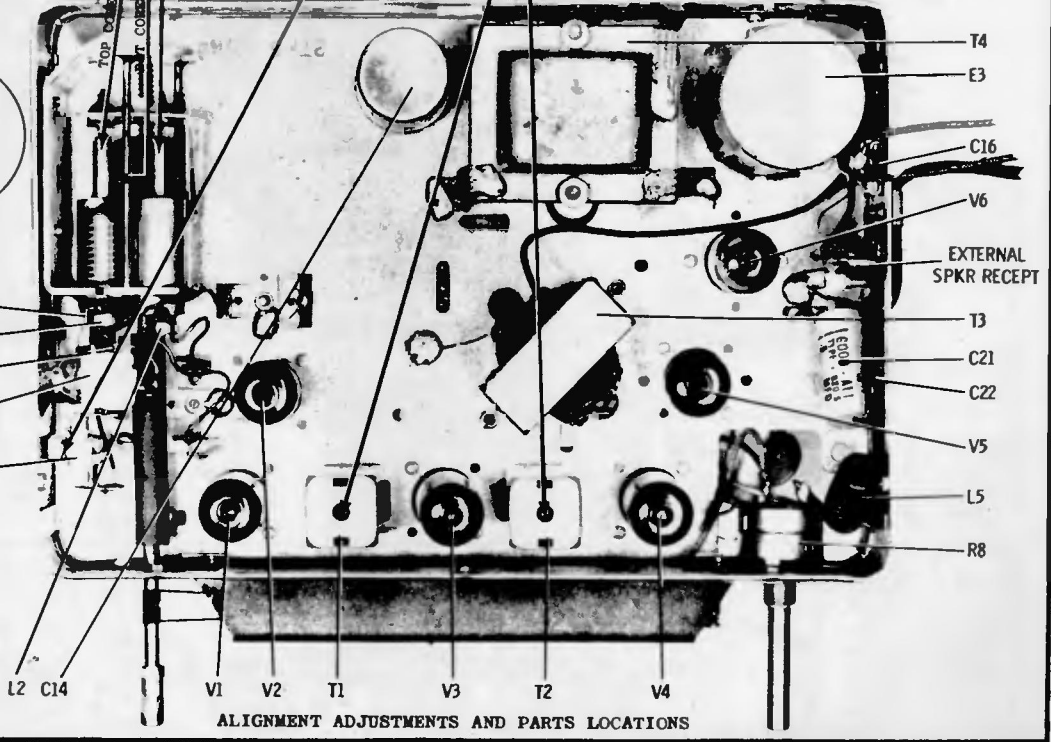

AMERICAN MOTORS

8990378

MOTOROLA

MOTOROLA R6MA

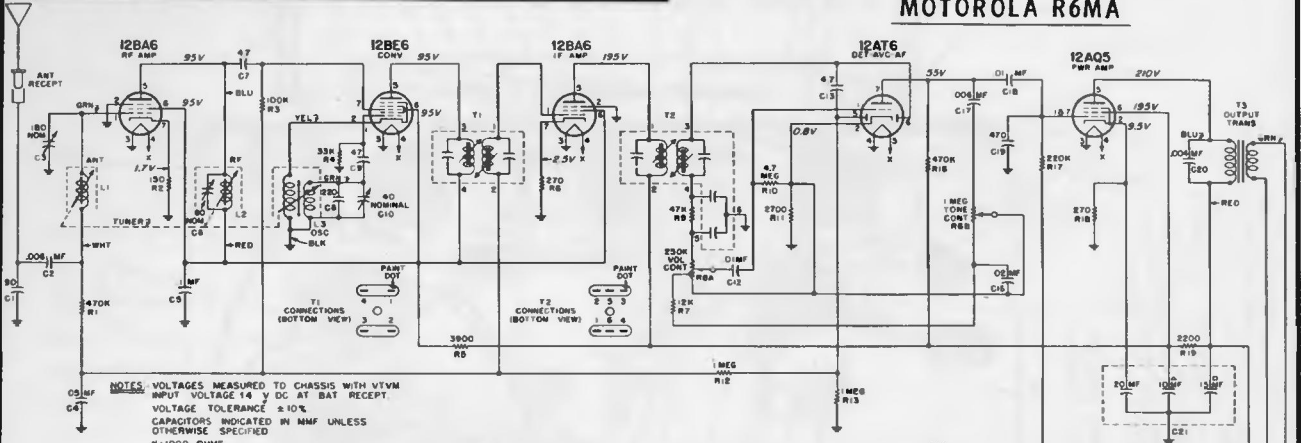

NOTES: VOLTAGES MEASURED TO CHASSIS WITH VTVM
 INPUT VOLTAGE 14 V DC AT BAT RECEPT
 VOLTAGE TOLERANCE ±10%
 CAPACITORS INDICATED IN MMF UNLESS OTHERWISE SPECIFIED
 R=1000 OHMS

IF = 455 KC
 FREQUENCY RANGE
 340 KC - 1800 KC

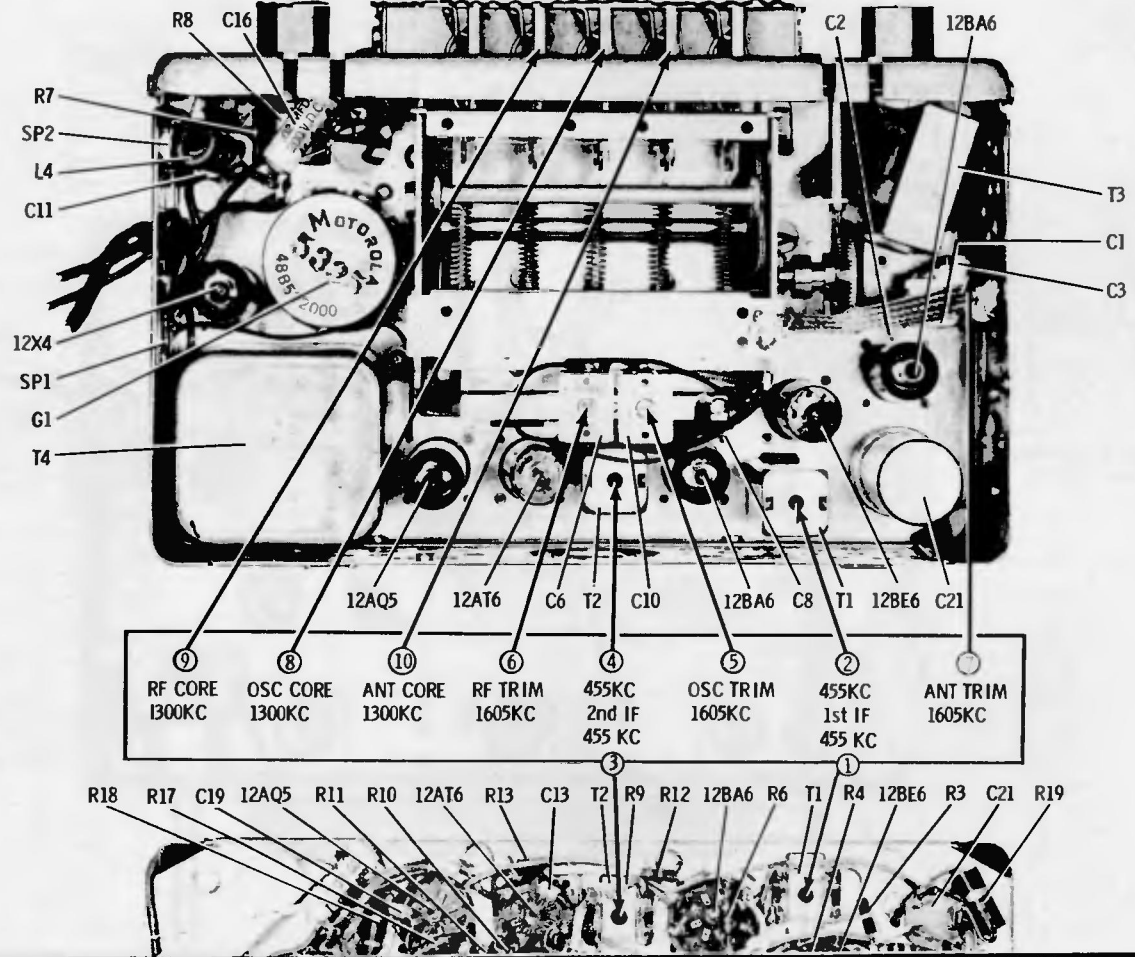
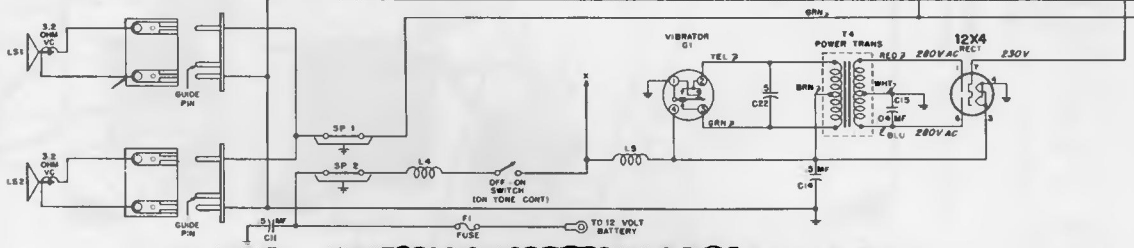

9	8	10	6	4	5	2	1
RF CORE	OSC CORE	ANT CORE	RF TRIM	455KC	OSC TRIM	455KC	ANT TRIM
1300KC	1300KC	1300KC	1605KC	2nd IF	1605KC	1st IF	1605KC
				455 KC		455 KC	

MOTOROLA

MODELS

- 555
- 555 - 12
- 595
- 595 - 12

TUBES

Ref. No.	555 & 595	555-12 & 595-12
V1	6BD6 (RF)	12BD6 (RF)
V2	6BE6	12BE6
V3	6BD6 (IF)	12BD6 (IF)
V4	6CR6	12CR6
V5	6AQ5	12AQ5
V6	6X4	12X4

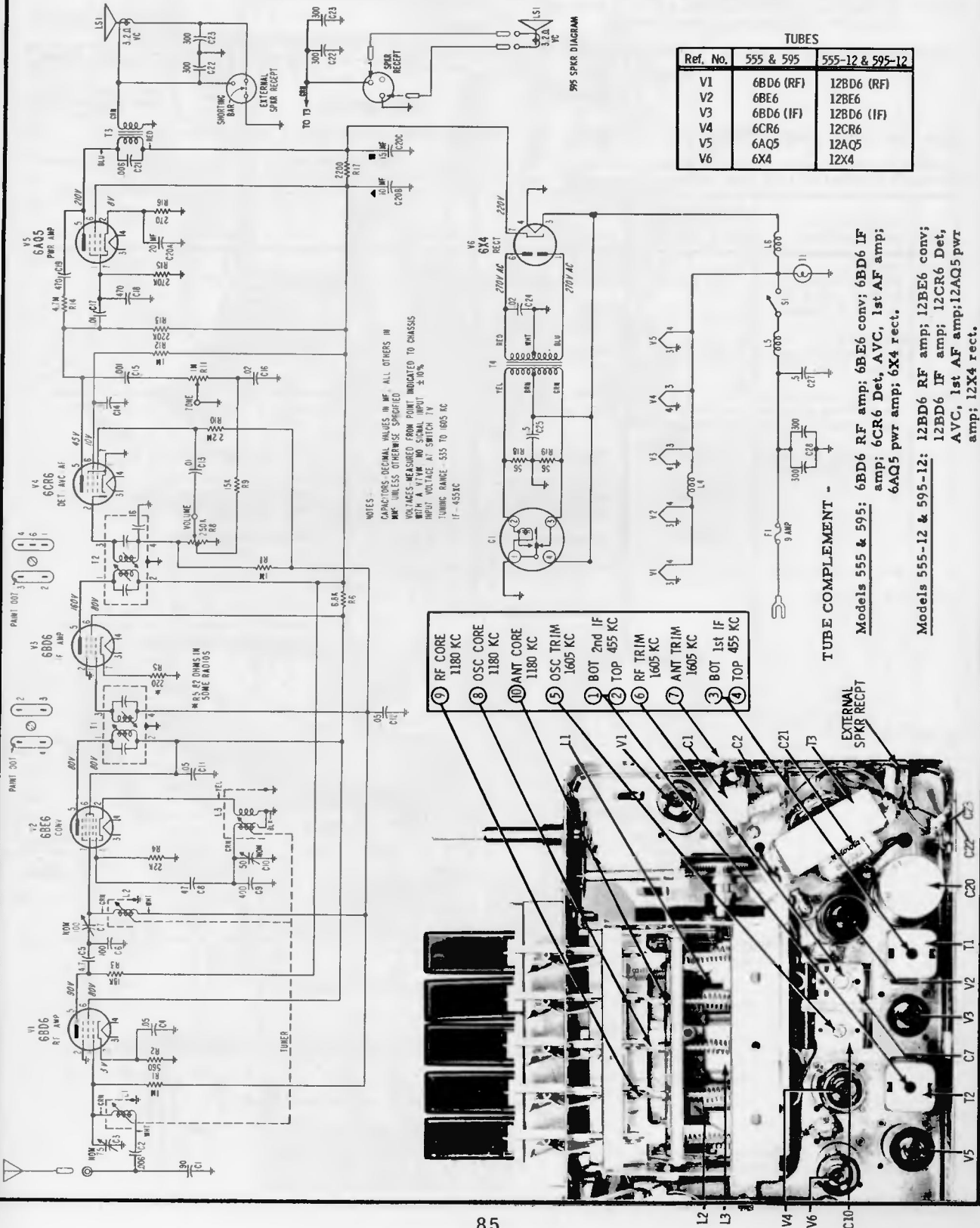

MOTOROLA

AUTO RADIO

MODEL
556

TYPE - Universal automotive type superheterodyne receiver designed for underdash mounting. Receiver may be mounted in-dash with an AK-111A trim plate. This model contains an internal speaker.

TUNING RANGE - 540 to 1600 Kc IF - 455 Kc

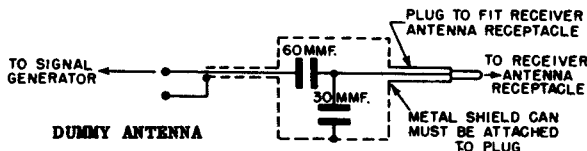

ALIGNMENT

See the next page, adjacent at right, for location of alignment adjustments.

Connect an output meter across the speaker voice coil. Set tone control to high and volume to maximum. Attenuate generator output to maintain 1.79 volts on output meter at all times to prevent overloading the receiver.

STEP	GENERATOR CONNECTION	GENERATOR FREQUENCY (400 cycle mod)	TUNER SET TO	ADJUST	REMARKS
IF ALIGNMENT					
1.	6BE6 grid (pin 7) through .1 mf capacitor & chassis	455 Kc	Hi end stop	1, 2, 3 & 4	Peak for maximum
RF ALIGNMENT					
2.	Ant recept through dummy (see Fig.)	1610 Kc	Hi end stop	5, 6 & 7	Peak for maximum
NOTE: Do not perform steps 3, 4, 5 & 6 unless tuner has been tampered with or components have been replaced. Remove escutcheon to expose core screws. Before proceeding with step 3, back tuning cores 1" out of coils to eliminate their effect on trimmer adjustments.					
3.	Ant recept through dummy (see Fig.)	1610 Kc	Hi end stop	5, 6 & 7	Peak for maximum
4.	"	1180 Kc	19/64" from hi end stop	8, 9 & 10	Peak for maximum using alignment tool, Motorola Part No. 66A76278
5.	"	1610 Kc	Hi end stop	5, 6 & 7	Peak for maximum
6.	Repeat steps 4 and 5 until no further increase, then cement tuning cores in place.				
ANTENNA TRIMMER					
7.	-	-	Weak station around 1400 Kc	7	With radio installed in car and antenna fully extended, peak antenna trimmer for maximum.

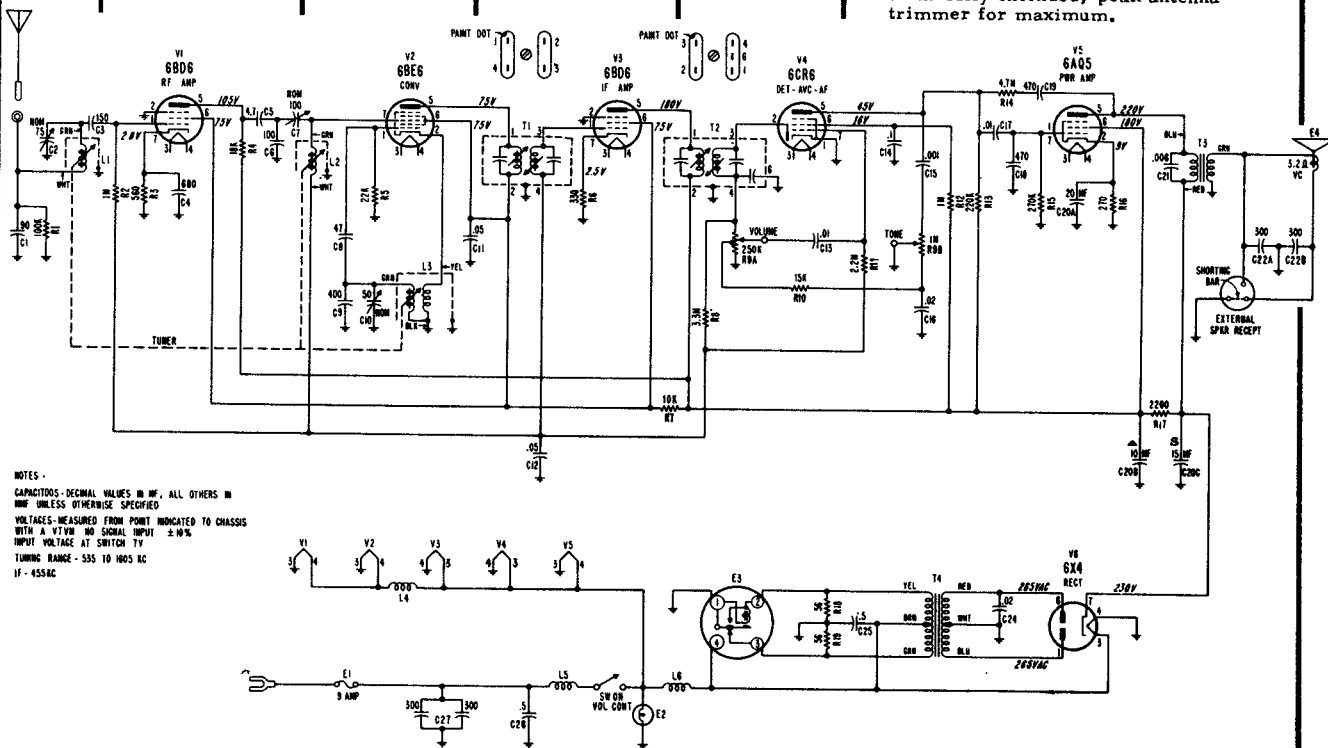

NOTES -
CAPACITORS - DECIMAL VALUES IN MF, ALL OTHERS IN MMF UNLESS OTHERWISE SPECIFIED
VOLTAGES - MEASURED FROM POINT INDICATED TO CHASSIS WITH A VTVM NO SIGNAL INPUT ± 10%
INPUT VOLTAGE AT SWITCH 7V
TUNING RANGE - 535 TO 1605 KC
IF - 455 KC

MOTOROLA INC.

Model 556

Additional alignment data, continued from preceding page at left.

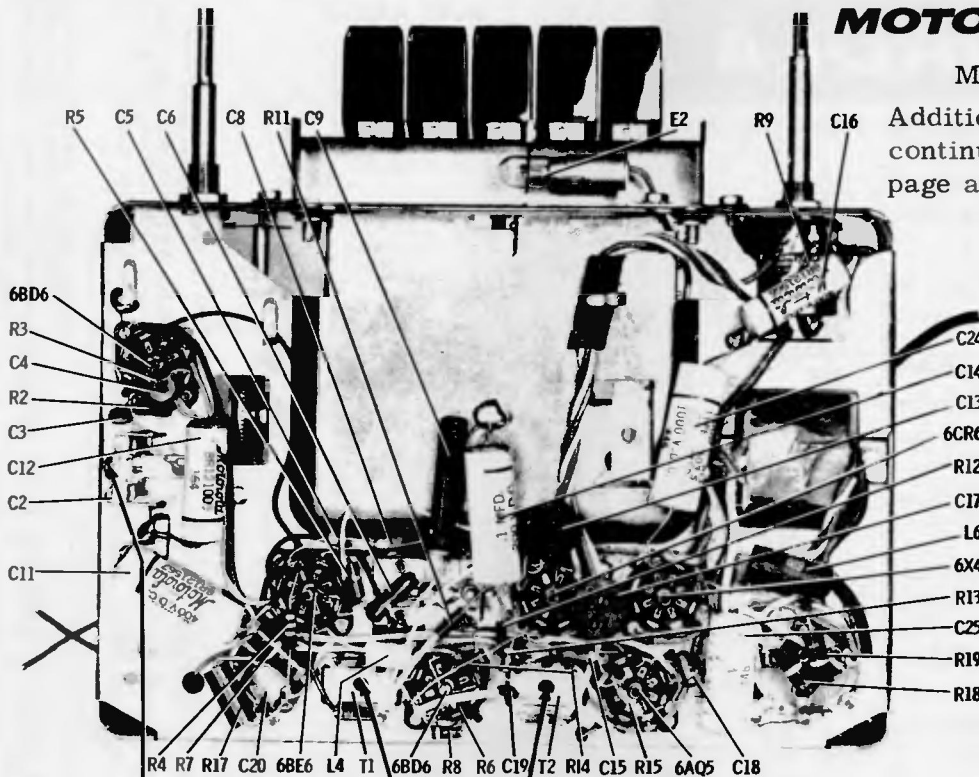

- | | | | |
|-----------------------|--------------------|--------------------|-----------------------|
| ① ANT TRIM
1610 KC | ② 1st IF
455 KC | ④ 2nd IF
455 KC | ⑩ ANT CORE
1180 KC |
| ⑥ RF TRIM
1610 KC | ① 1st IF
455 KC | ③ 2nd IF
455 KC | ⑧ OSC CORE
1180 KC |
| ⑤ OSC TRIM
1610 KC | | | ⑨ RF CORE
1180 KC |

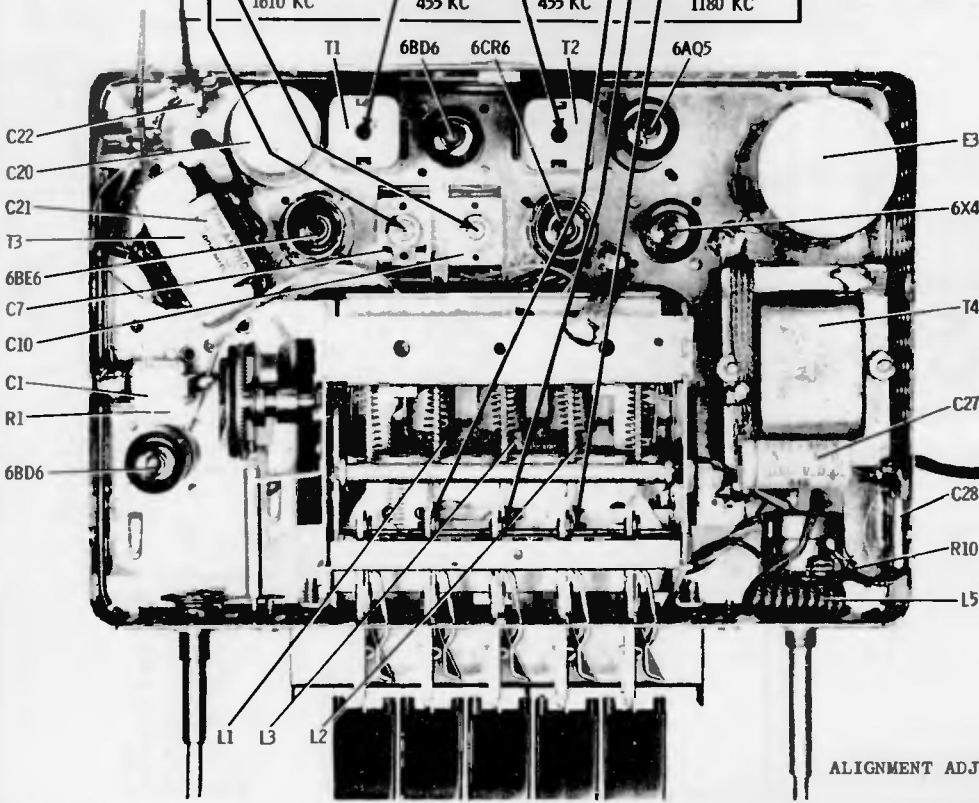

TO SET PUSHBUTTONS

- This receiver has an automatic tuner, with 5 "Quick Set" pushbuttons for automatic station selection.
- To set the pushbuttons for automatic tuning, proceed as follows:
1. Tune in the desired station with the manual tuning knob.
 2. Tune carefully until you are exactly on the station.
 3. Pull out the first pushbutton to be set, to unlock the button for station set-up, and then push button in firmly to set and lock the button.
 4. Follow the above procedure for the remaining four buttons.

ALIGNMENT ADJUSTMENTS & PARTS LOCATION

MOTOROLA

AUTO RADIO

MODELS

596
596-12

(See next page, adjacent at right, for alignment)

TUBE COMPLEMENT
 Model 596: 6BD6 RF amp; 6BE6 conv; 6BD6 IF amp; 6CR6 Det-AVC-AF amp; 6AQ5 pwr amp; 6X4 rect.
 Model 596-12: 12BD6 RF amp; 12BE6 conv; 12BD6 IF amp; 12CR6 Det-AVC-AF amp; 12AB5 pwr amp; 12X4 rect.

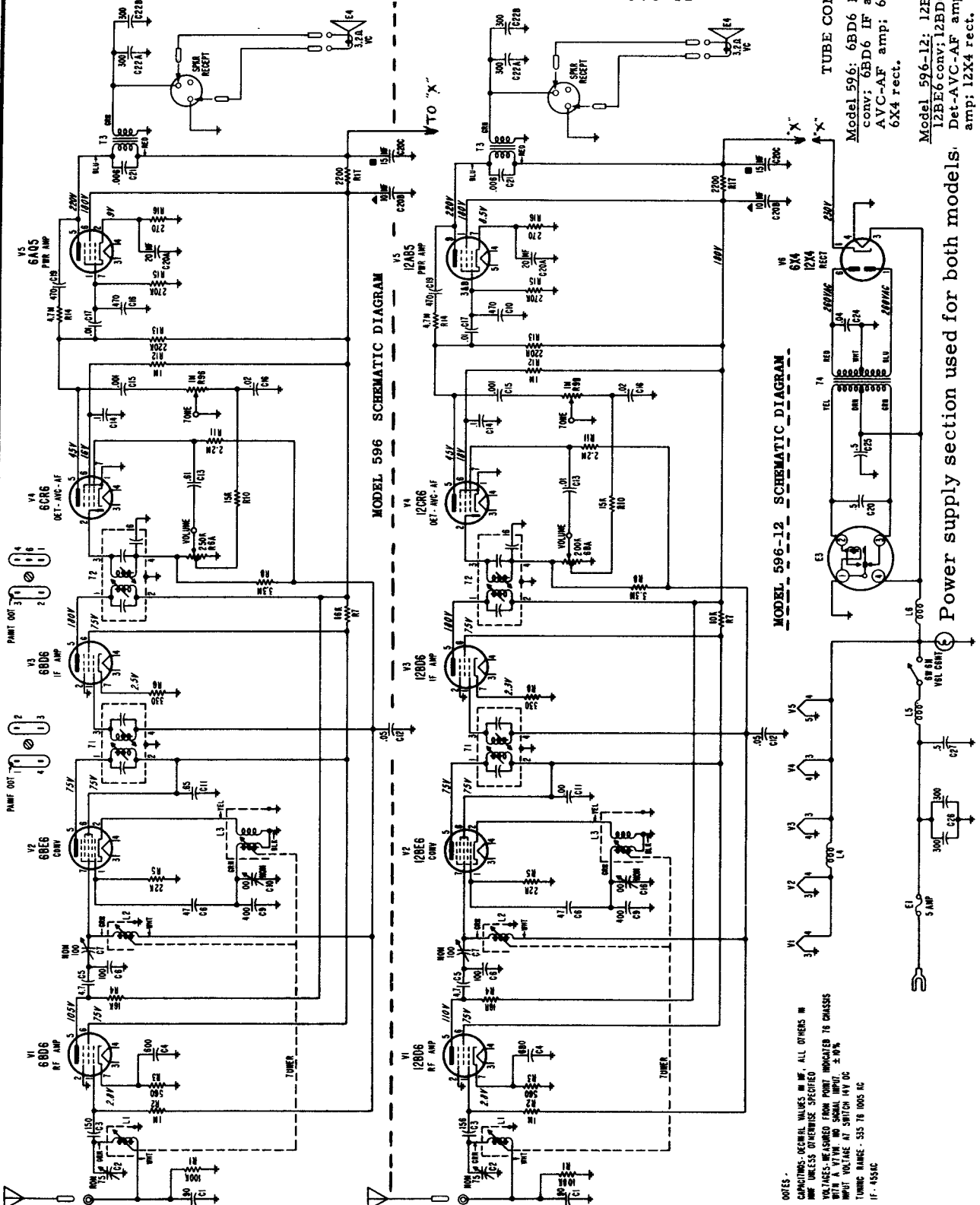

NOTES:
 CAPACITANCE: DECIMAL VALUES IN μ ALL OTHERS IN MMF
 UNLESS OTHERWISE SPECIFIED
 VOLTAGES: MEASURED FROM POINT INDICATED TO GROUND
 WITH SET IN TUNING AND SIGNAL INPUT $\pm 0.5\%$
 TUNING: RANGE - 535 TO 1605 KC
 IF - 455 KC

MOTOROLA INC.

Models 596 and 596-12
Alignment Information
(Continued from preceding page adjacent at left.)

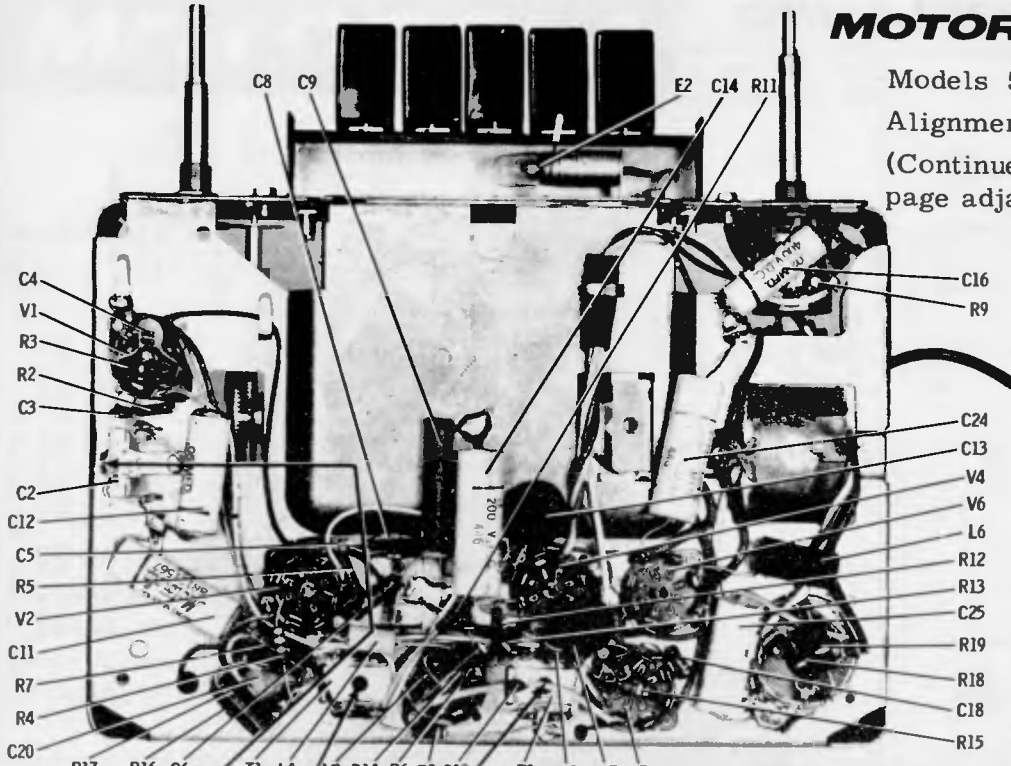

TUBES			
REF NO	596	596-12	
V1	6BD6 (RF)	12BD6 (RF)	ANT TRIM 1610 KC
V2	6BE6	12BE6	OSC TRIM 1610 KC
V3	6BD6 (IF)	12BD6 (IF)	RF TRIM 1610 KC
V4	6CR6	12CR6	1ST IF 455 KC
V5	6AQ5	12AB5	2ND IF 455 KC
V6	6X4	12X4	RF CORE 1180 KC

TO SET PUSHBUTTONS

1. Tune in the desired station with the manual tuning knob.
2. Pull out the first pushbutton to be set, to unlock the button for station set-up, and then push button in firmly to set and lock the button.
3. Follow the above procedure for the remaining four buttons.

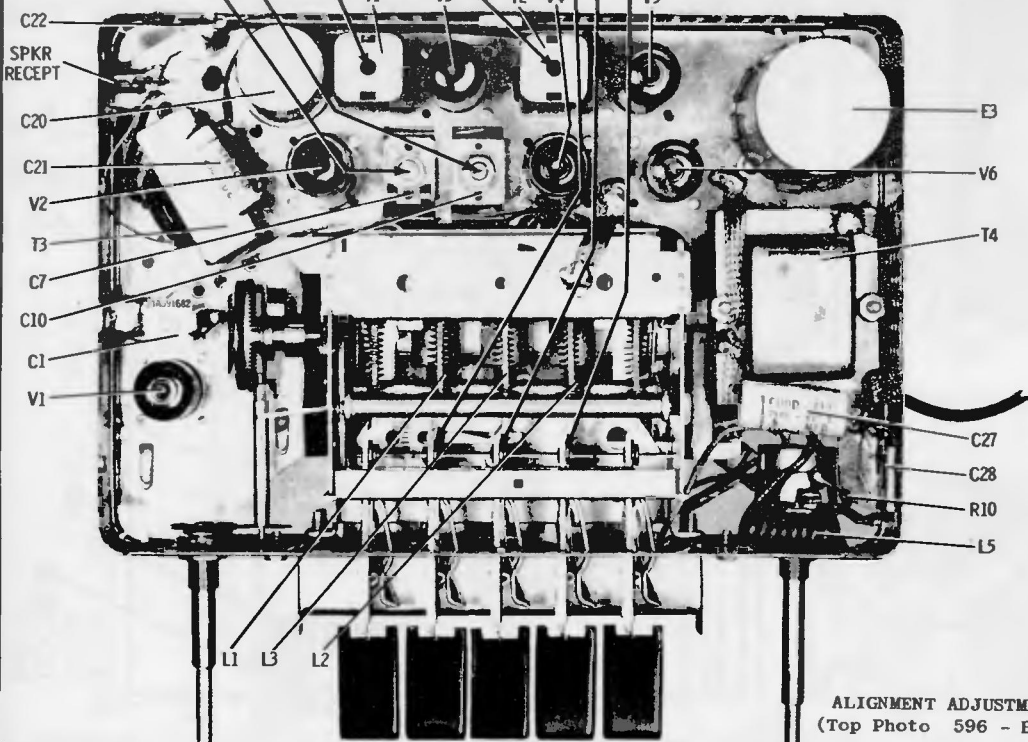

- This receiver has an automatic tuner, with 5 "Quick Set" pushbuttons for automatic station selection.
- To set the pushbuttons for automatic tuning, proceed as follows:
1. Tune in the desired station with the manual tuning knob.

ALIGNMENT ADJUSTMENTS & PARTS LOCATION
(Top Photo 596 - Bot Photo 596 & 596-12)

MOTOROLA INC.

MODELS

MoPar 620
MoPar 621

TYPE - Automotive type superheterodyne receiver designed for custom installation in the following cars.
Model 620 - Plymouth P28, P29
Model 621 - Dodge D62, D63

TUNING RANGE - 540 to 1600 Kc IF - 455 Kc

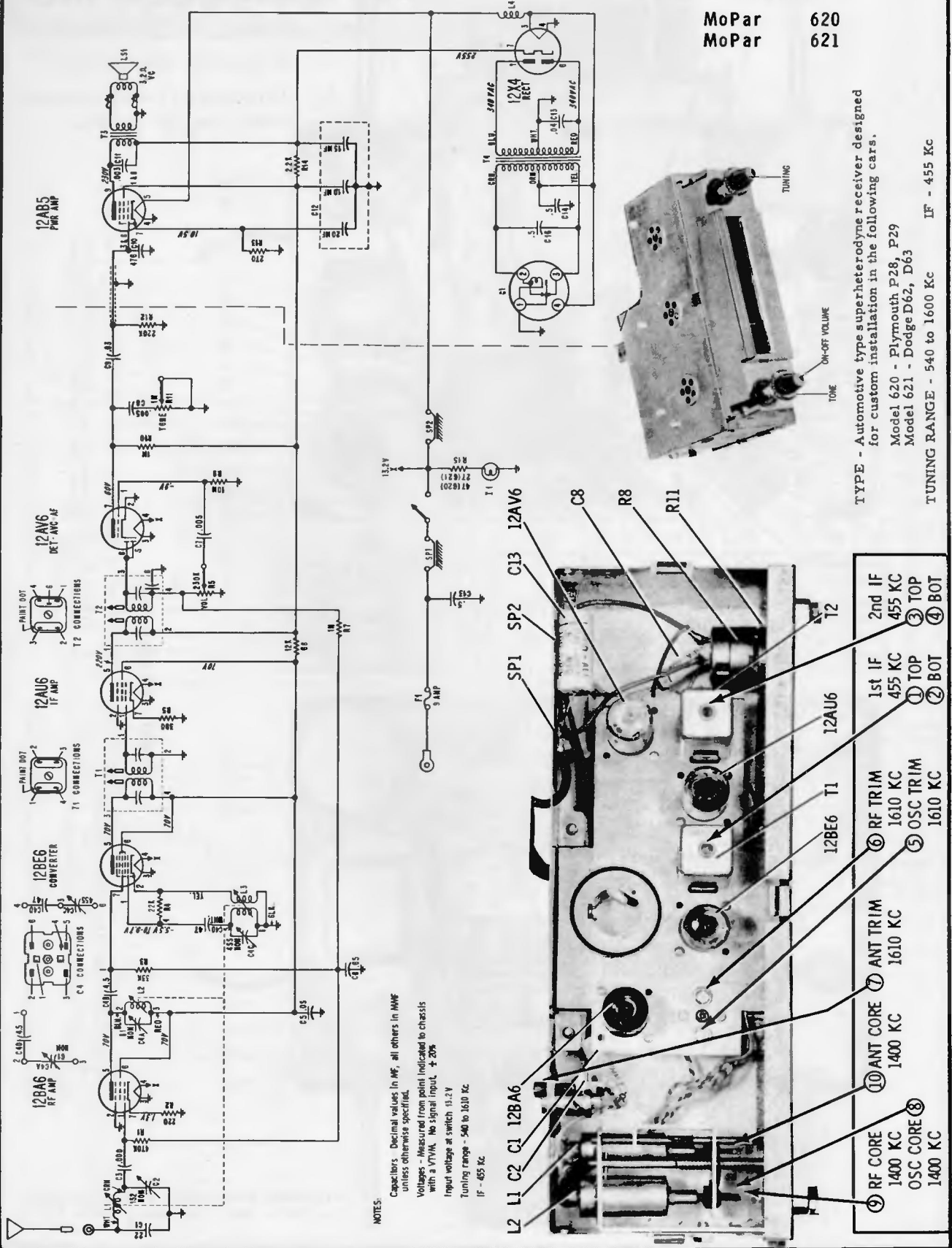

NOTES:
Capacitors - Decimal values in MF, all others in MMF unless otherwise specified.
Voltages - Measured from point indicated to chassis with a VTVM. No signal input, $\pm 20\%$
Input voltage at switch 13.2 V
Tuning range - 540 to 1600 Kc
IF - 455 Kc

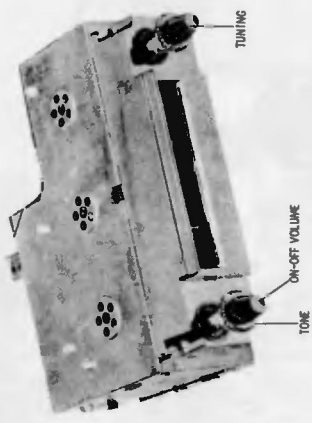

MOTOROLA

MODELS
 MoPar 841
 MoPar 842
 MoPar 843

Model 841 - Plymouth P28, P29
 Model 842 - Dodge D62, D63
 Model 843 - DeSoto S23, S24

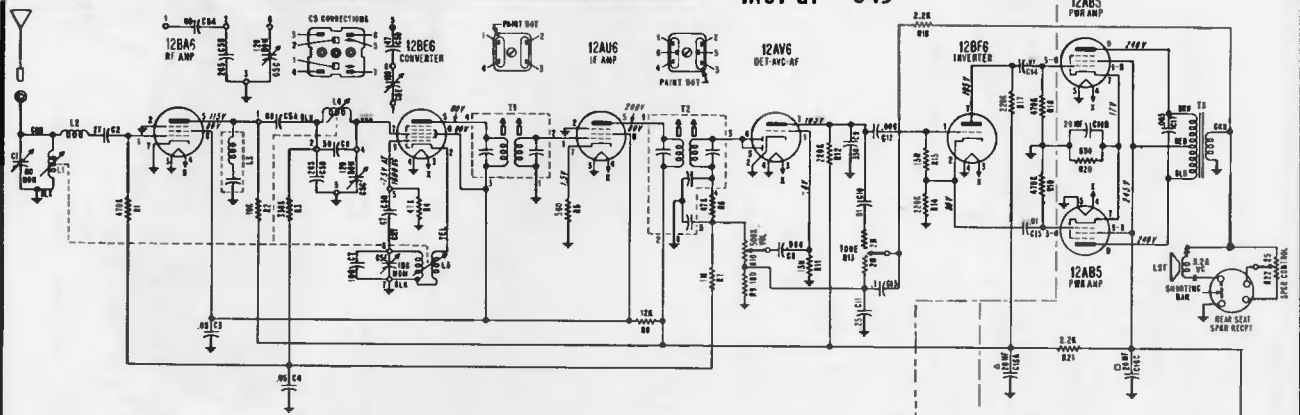

The circuit above is exact for Model 841. Models 842 and 843 are practically identical except for a HI-FI input receptacle.

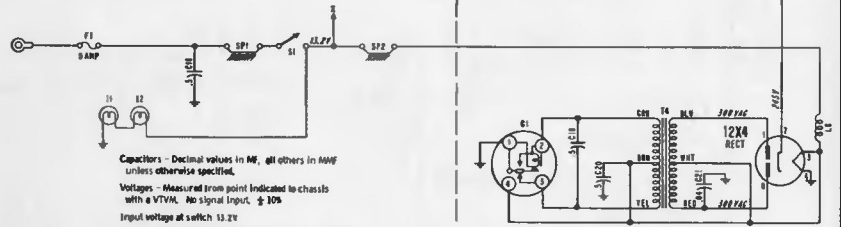

Capacitors - Decimal values in MF, all others in MMF unless otherwise specified.
 Voltages - Measured from point indicated to chassis with a VTVM, no signal input, $\pm 30\%$
 Input voltage at switch 112V

TOP VIEW POWER SUPPLY 841, 842 & 843

HI WAY HI-FI RECEPT (not used on 841)
 12BF6 SPI C18 L4 C6 C7 L5 L1 C1 L2 12BA6 12BE6

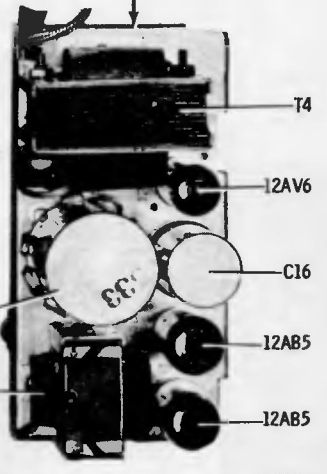
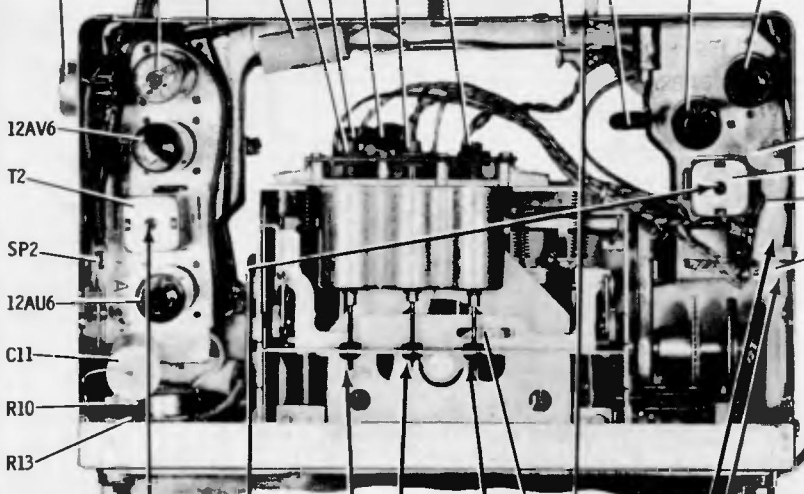

- | | | |
|---------------------------|-----------------------|-----------------------|
| ③ 2nd IF
262 KC
TOP | ⑩ ANT CORE
1000 KC | ⑦ ANT TRIM
1615 KC |
| ④ 1st IF
262 KC
BOT | ⑧ OSC CORE
1000 KC | ⑥ RF TRIM
1615 KC |
| ① TOP | ⑨ RF CORE
1000 KC | ⑤ OSC TRIM
1615 KC |
| ② BOT | | |

ALIGNMENT ADJUSTMENTS & PARTS LOCATIONS

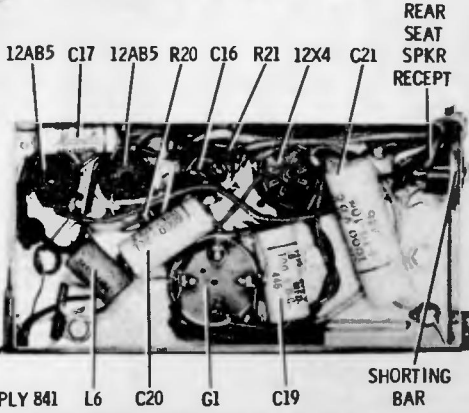

BOTTOM VIEW POWER SUPPLY 841

MOTOROLA INC.

MODELS

MoPar 910
MoPar 911

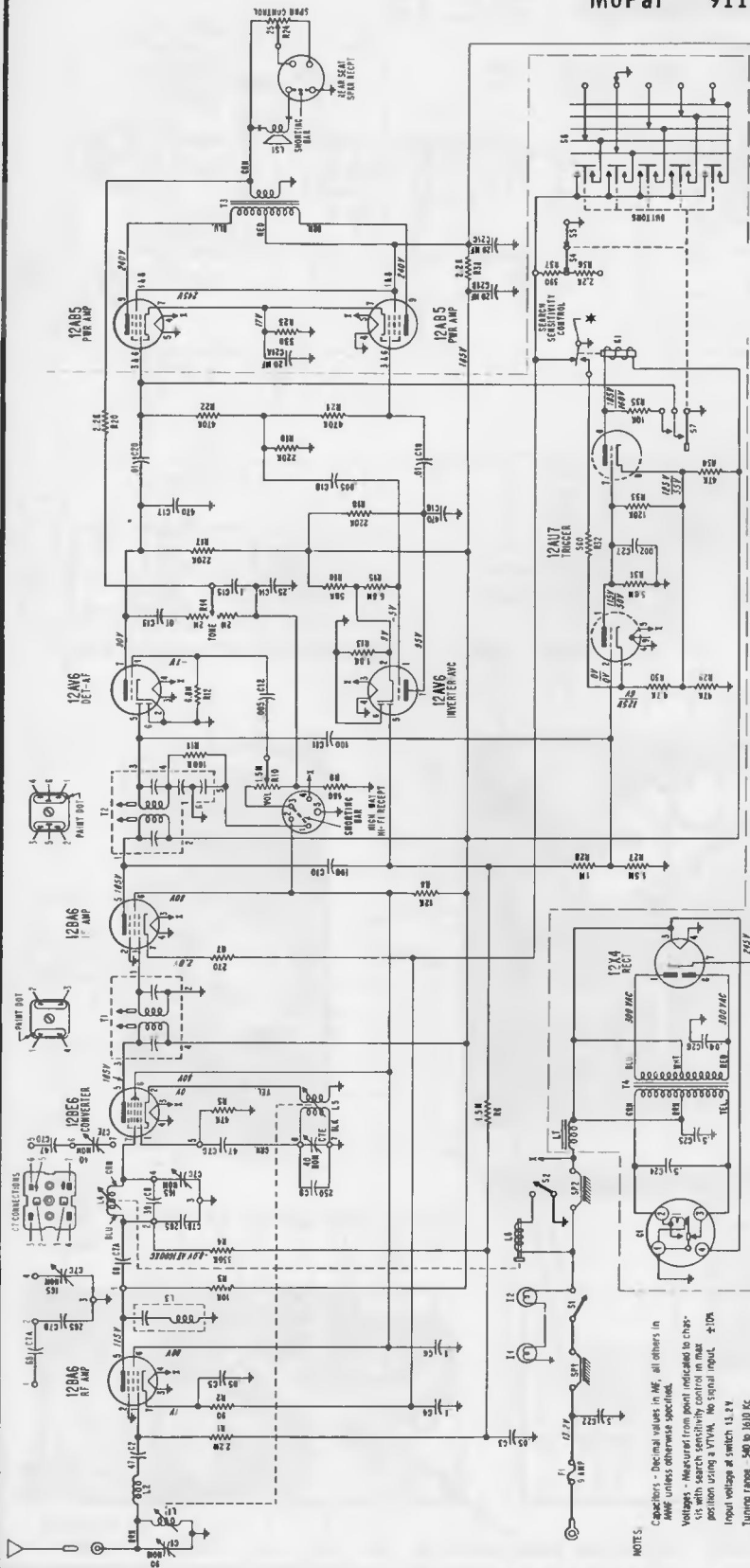

TARGER TUBE VOLTAGES
11 - BOMBING OPERATOR RELAY BUYS
12 - POWER SECTOR RELAY DISCLOSED

NOTES
Capacitors - Decimal values in μ F, all others in μ M unless otherwise specified.
Voltages - Measured from point indicated to chassis with search sensitivity control in max position using a VTVM. No signal input. $\pm 10\%$ input voltage at switch 15, 14.
Tuning range - 540 to 1610 Kc.
IF - 352 Kc.

TYPE - Automotive type superheterodyne receiver incorporating a search tuner. These receivers are custom designed for installation in the following cars:

- MoPar 910 - Dodge D62, D63
- MoPar 911 - DeSoto S23, S24

TUNING RANGE - 540 to 1610Kc IF - 262 Kc

TO SET PUSHBUTTONS

1. Turn receiver on and allow to operate for fifteen minutes. Antenna should be fully extended.
2. Open the hinged tab cover below the dial scale, exposing the five red pushbutton setting tabs.
3. Starting at left end of dial, tune in manually first desired station and move the first pushbutton setting tab until it lines up with the dial pointer tip.
4. Repeat step 3 for the remaining pushbutton setting tabs.
5. Check the settings of each pushbutton setting tab by depressing the corresponding station selector button. If the station is not tuned in exactly, readjust the tab.
6. Pushbutton setting should be done in sequence from left to right, using the pushbutton setting tabs in the same sequence.

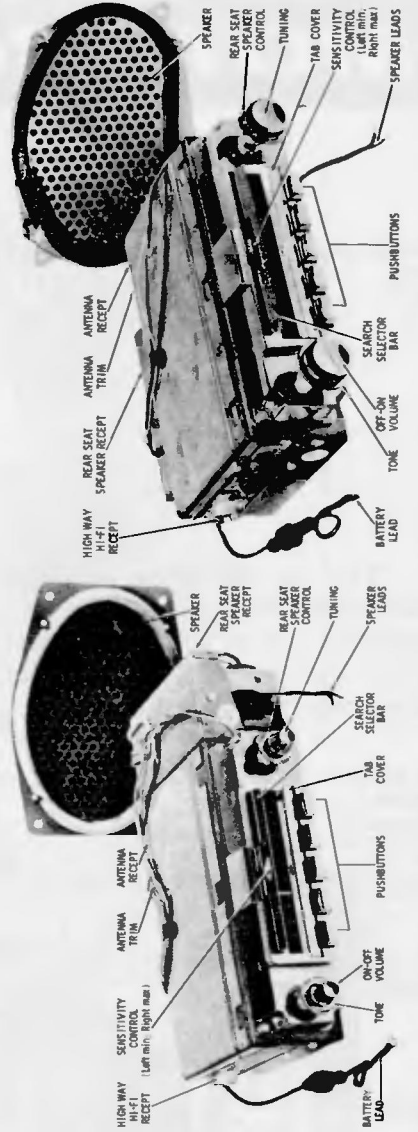

MODEL 911

MODEL 910

MOTOROLA INC.

MODEL
MoPar 916

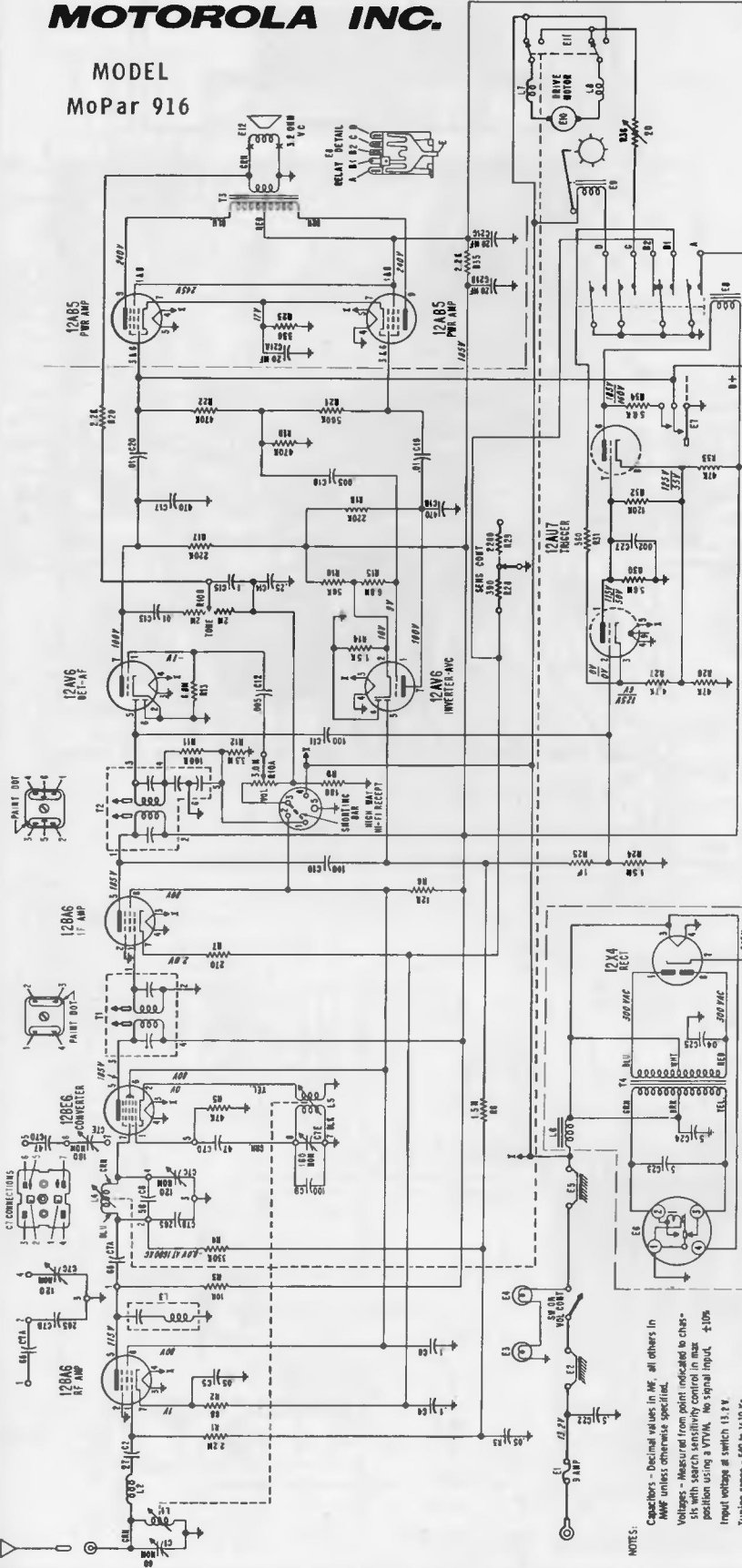

TO SET PUSHBUTTONS

Stations may be set up in any order. However, for convenience in remembering, it is suggested that stations be set up in frequency sequence.

1. Turn receiver on and allow to operate for fifteen minutes. Antenna should be fully extended.
2. Unlock pushbuttons by pulling them to the left and out.
3. Accurately tune in a station with the manual tuning.
4. Lock one pushbutton to that station by pushing in firmly.
5. Repeat above procedure for remaining pushbuttons.

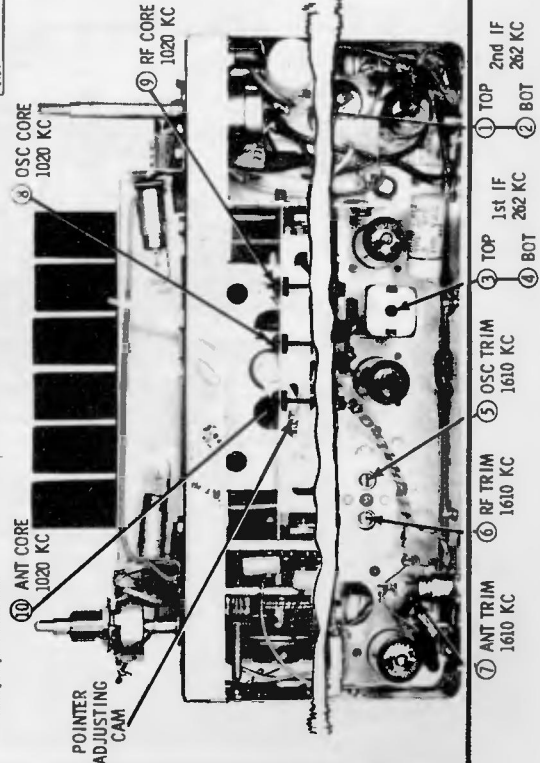
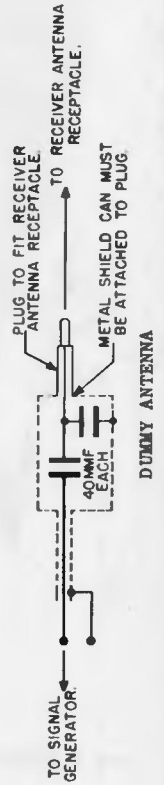

NOTES:
Capacitors - Decimal values in MF, all others in MMF unless otherwise specified.
Voltages - Measured from point indicated to chassis with search sensitivity control in max position using a VTVM. No signal input. $\pm 10\%$ input voltage at switch 15.2V.
Tuning range - 540 to 1610 KC.

MOTOROLA INC.

AUTO RADIO

MOTOROLA 66MF

FORD FDR-18805-B1

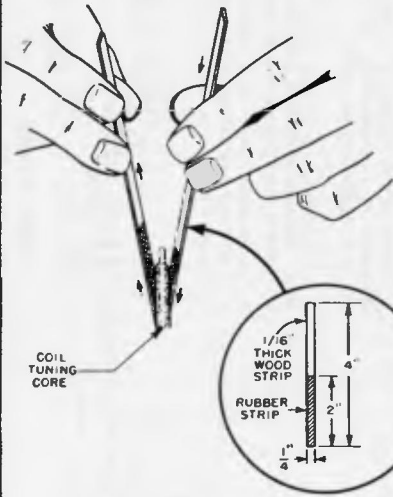

CORE ALIGNMENT TOOL DETAIL

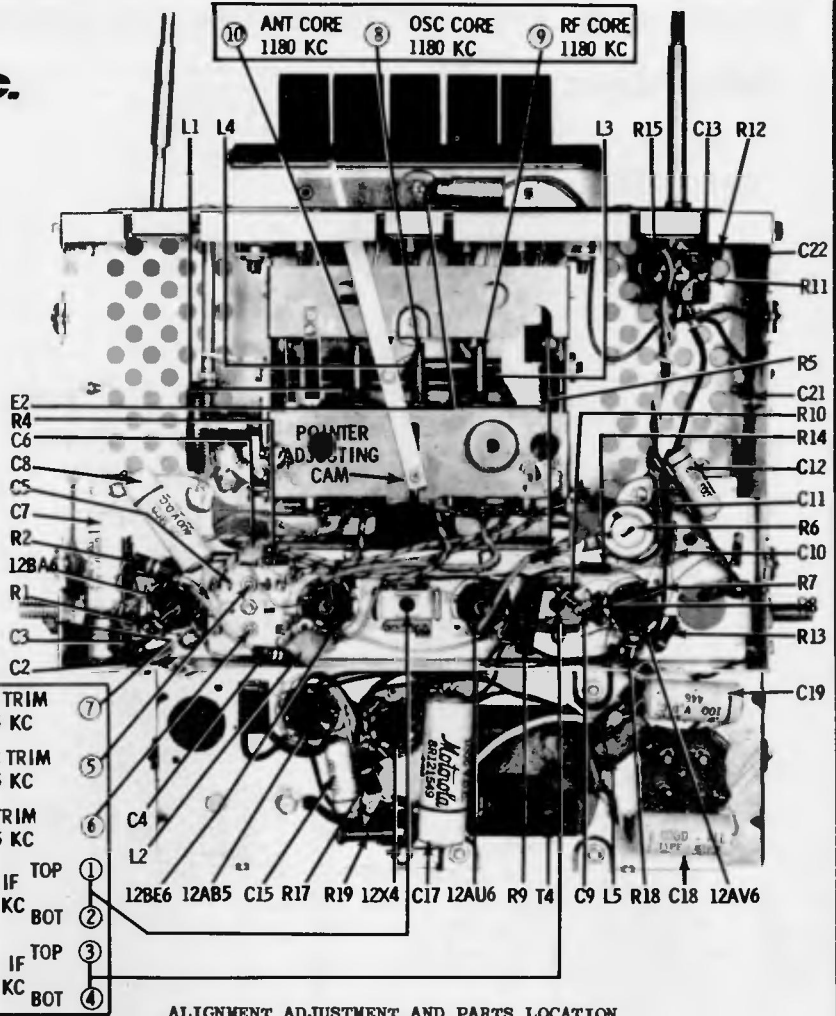

ALIGNMENT ADJUSTMENT AND PARTS LOCATION

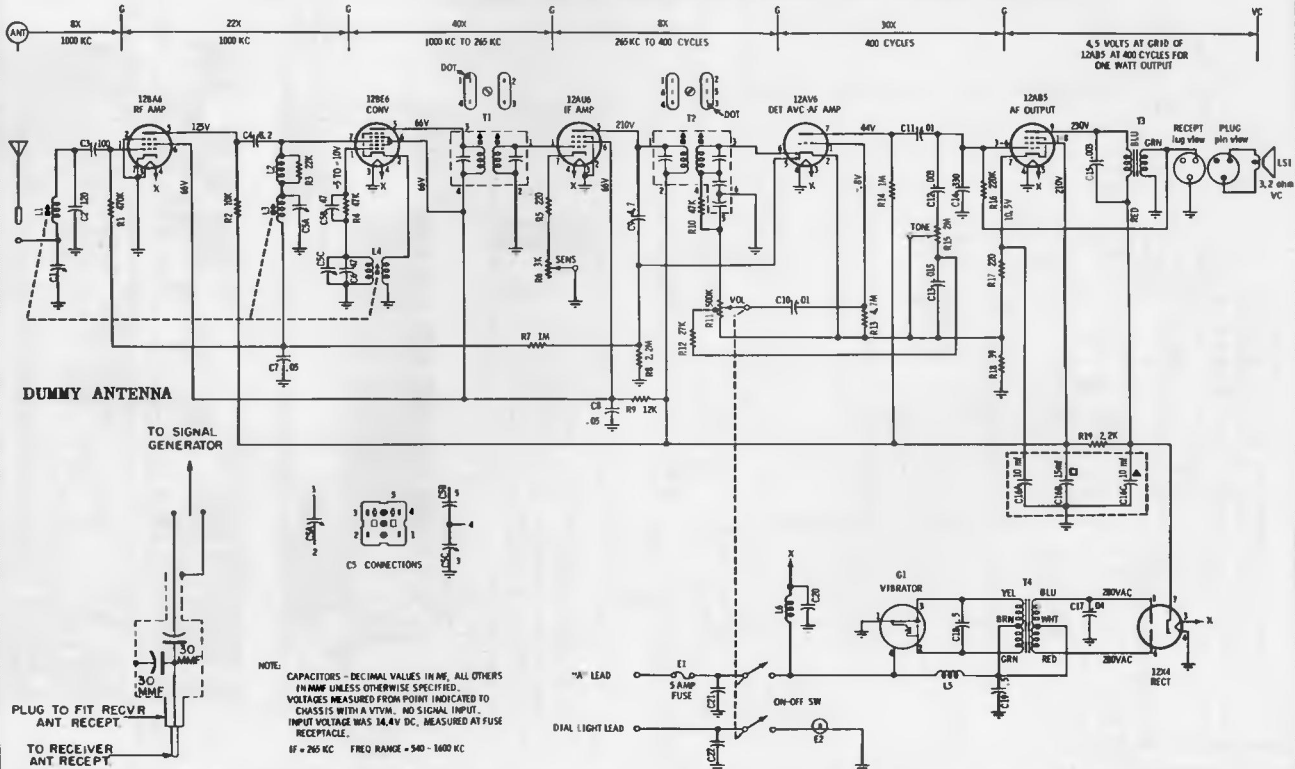

VOLUME R-16, MOST-OFTEN-NEEDED 1956 RADIO SERVICING INFORMATION

MOTOROLA 69MS FORD FEF-18805-B AUTO RADIO

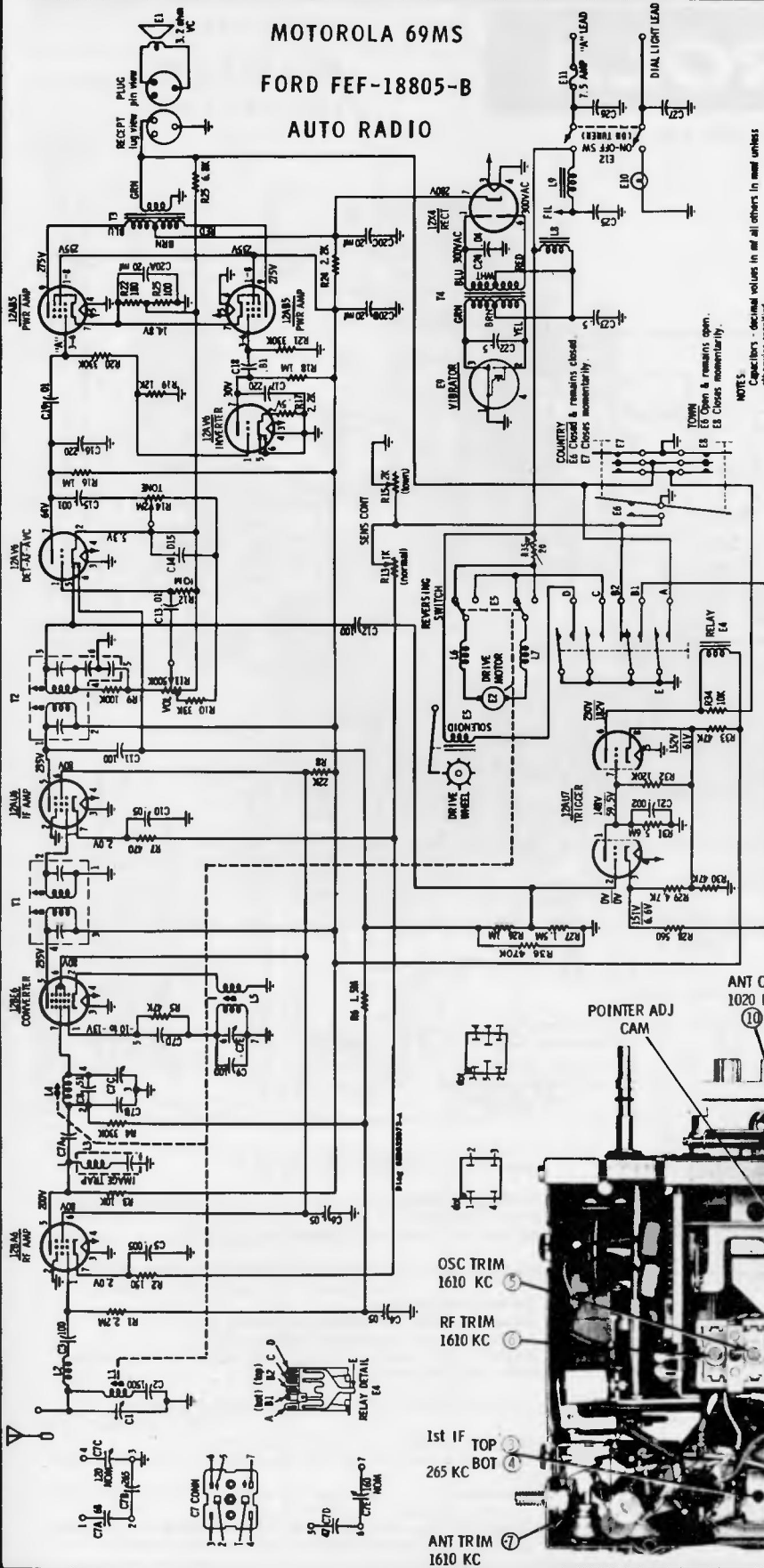

NOTES
Capacitors - decimal values in all others in read unless otherwise specified.
Voltages - measured from point indicated to chassis with a VTVM. No signal input. Input voltage 14.4 volts at end of "A" lead. polarity (+) negative, chassis (-) positive, end of "A" lead. Voltage readings taken with set in normal operation (not Searching)

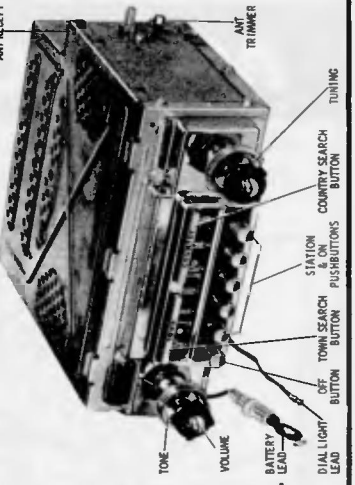

TRIGGER TUBE VOLTAGES
V1 - NORMAL OPERATION, RELAY 6A CLOSED
V2 - WHEN SEARCHING, RELAY 6A CLOSED

TYPE - Automotive type search tuned superheterodyne radio designed for installation in the 1956 Ford Thunderbird.

TO REPLACE DEFECTIVE MANUAL TUNING SHAFT

1. Remove escutcheon.
2. Remove roll pin from manual tuning shaft.
3. Remove defective manual tuning shaft.
4. Replace new manual tuning shaft using the new roll pin provided with the shaft.

TO REPLACE DEFECTIVE VOLUME CONTROL

1. Remove top cover and escutcheon.
2. Remove relay (it is not necessary to unsolder relay wires).
3. Unsolder wires and components from the dual control.
4. Remove volume control mounting clip.
5. Rotate volume control about 300° clockwise and pull out.
6. Replace new volume control in opposite manner.

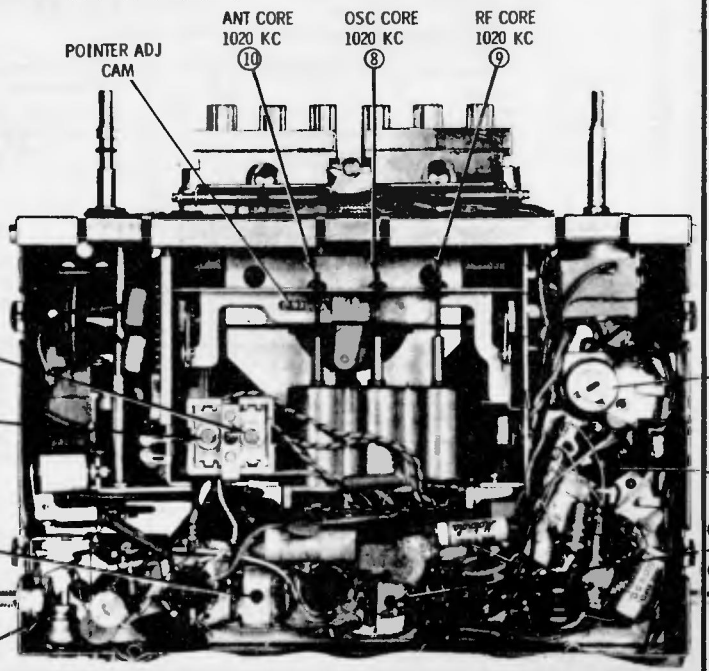

MOTOROLA

AUTO RADIO
MOTOROLA 69MF
FORD FDR-18806-F

(For alignment information see the next page, adjacent at right.)

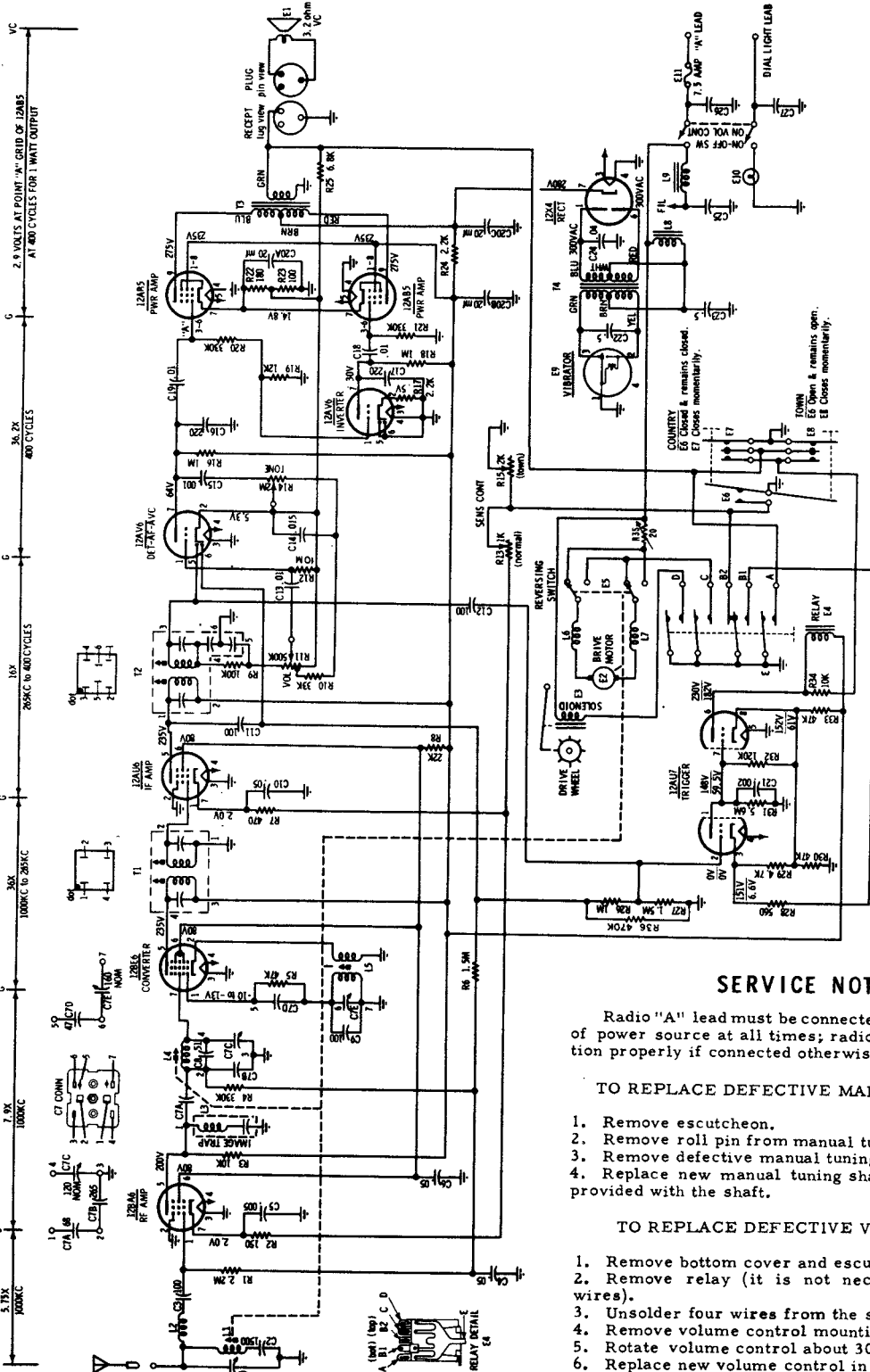

TO SET PUSHBUTTONS

- Stations may be set up in any order. However, for convenience in remembering, it is suggested that stations be set up in frequency sequence, from left to right.
1. Turn receiver on and allow to operate for fifteen minutes. Antenna should be fully extended.
 2. Unlock one of the pushbuttons by pulling it out.
 3. Accurately tune in a station with the manual tuning.
 4. Lock pushbutton to that station by pushing in firmly.
 5. Repeat above procedure for remaining pushbuttons.

SERVICE NOTES

Radio "A" lead must be connected to the positive (+) side of power source at all times; radio and tuner will not function properly if connected otherwise.

TO REPLACE DEFECTIVE MANUAL TUNING SHAFT

1. Remove escutcheon.
2. Remove roll pin from manual tuning shaft.
3. Remove defective manual tuning shaft.
4. Replace new manual tuning shaft using the new roll pin provided with the shaft.

TO REPLACE DEFECTIVE VOLUME CONTROL

1. Remove bottom cover and escutcheon
2. Remove relay (it is not necessary to unsolder relay wires).
3. Unsolder four wires from the switch.
4. Remove volume control mounting clip.
5. Rotate volume control about 30° clockwise and pull out.
6. Replace new volume control in opposite manner.

NOTES:
Capacitors - nominal values in all others in μmf unless otherwise specified.
Voltages - measured from point indicated in chassis with a VTVM, no signal input. Input voltage is 4 volts at end of "A" lead. Primary (1) frequency, chassis (1) positive, end of "A" lead. Voltage readings taken with set in normal operation (not searching) whenever specified.
TRIGGER TUBE VOLTAGES: VI NORMAL OPERATION, RELAY E4 OPEN; V2 WHEN SEARCHING, RELAY E4 CLOSED.

(Alignment on the next page)

VOLUME R-16, MOST-OFTEN-NEEDED 1956 RADIO SERVICING INFORMATION

MOTOROLA Auto Radio 69MF, Ford FDR-18806-F
Alignment Information, Circuit diagram is on pre-
ceding page adjacent at left.

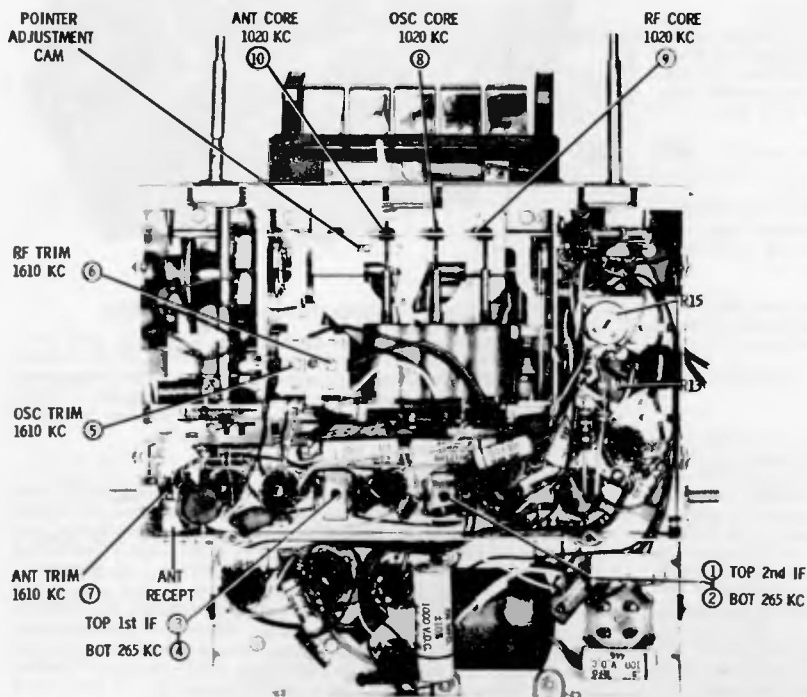

ALIGNMENT ADJUSTMENT LOCATION DETAIL

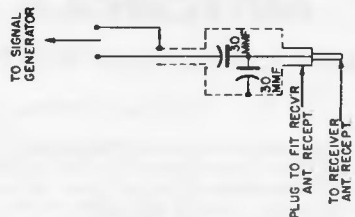

DUMMY ANTENNA DETAIL

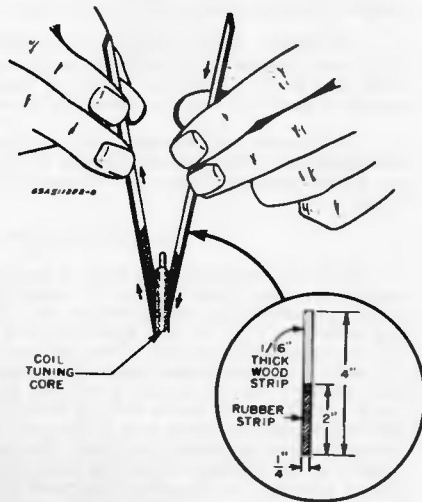

CORE ALIGNMENT TOOL DETAIL

ALIGNMENT

Connect a VTVM from the AVC line to ground. Set volume to minimum and tone to treble. Attenuate signal generator to maintain VTVM reading between 1.5 and 2 volts.

STEP	GENERATOR CONNECTION	GENERATOR FREQUENCY	TUNER SET TO	ADJUST	REMARKS
IF ALIGNMENT					
1.	12BE6 grid (pin 7) thru .1 mf & chassis	265 Kc	Hi end stop	2, 3, 4,	Adjust for maximum.
2.	"	265 Kc	Hi end stop	1	Adjust for dip.
RF ALIGNMENT - NOTE: Back tuning cores completely out of coils before proceeding.					
3.	Ant recept thru dummy. See Fig.	1610 Kc	Hi end stop	5, 6, 7	Adjust for maximum.
4.	"	1020 Kc	49/64" from hi end stop	8, 9, 10	Adjust for maximum
5. Repeat steps 3 & 4 until no further increase, then cement cores in place.					
SENSITIVITY CONTROLS - NOTE: Connect an output meter across speaker voice coil.					
6.	Ant recept thru dummy. See Fig.	1000 Kc at 5 microvolts	Tune for max	R13	Adjust for 1.79 volts (1 watt output)
7.	"	1000 Kc at 100 microvolts	Tune for max	R15	Turn set off. Depress and release TOWN button (left side). Turn set on. Open contact B2 by inserting insulation (paper) between contacts on relay E4 and adjust for 1.79 volts output.
8.	ANT TRIMMER ADJ	-	Weak station around 1400 Kc	7	Adjust for maximum with radio in car. Antenna should be fully extended.
POINTER CALIBRATION					

Tune radio to 1000 Kc signal and adjust the pointer adjusting cam (see Alignment photo) until the pointer lines up with the calibration mark on the dial background.

MOTOROLA INC.

SEARCH TUNER 77E535500 (MODEL ST-162)

(Used in Auto Radio 69MF and others)

GENERAL INFORMATION

This search tuner is a combination mechanical push-button tuner (with manual tuning) coupled to a search drive unit. This system provides three different methods of tuning the radio: manual tuning; pushbutton tuning; search tuning. The frequency range covered is 540 to 1600 Kc.

The pushbuttons tune to any one of five favorite radio stations to which they have been pre-set.

For search tuning, there are two different buttons; a "T" (town) button for tuning the radio to strong local stations and a "C" (country) button for tuning the radio when farther away from local broadcasting areas.

This radio will search radio stations with the tuner sweeping from either the high end to the low end of the band or while sweeping from the low end to the high end of the band.

MANUAL TUNING

When the manual tuning shaft is turned, the tuning gear and pinion gear (see Figure 2) rotate the crown gear and pinion assembly (6), which rotates the split gear and bushing assembly (7). As the split gear and bushing assembly (7) is frictionally coupled to the clutch and disc assembly (4), which is fixed to the treadle bar assembly, the treadle bar assembly moves the cores (5) in or out of the coils (L1, L4 & L5). Figure 3 shows that the different angles to which the treadle bar assembly may be moved, correspond to different frequency radio stations. The power transfer sequence is as follows: from the pinion gear of the manual tuning shaft (21) to the crown gear and pinion assembly (6), from the crown gear and pinion assembly (6) to the split gear and bushing assembly (7), from the split gear and bushing assembly (7) to the clutch and disc assembly (4), from the clutch and disc assembly (4) to the treadle bar assembly which moves the cores (5). The pinion gear of the tuner drive shaft (22) contacts the tuning gear of the manual tuning shaft (21). Therefore, when the manual tuning shaft (21) is turned, the tuner drive shaft (22) turns along with it. The tuner drive shaft (22) couples the manual tuning shaft (21) to the search drive unit. As the power take-off gear

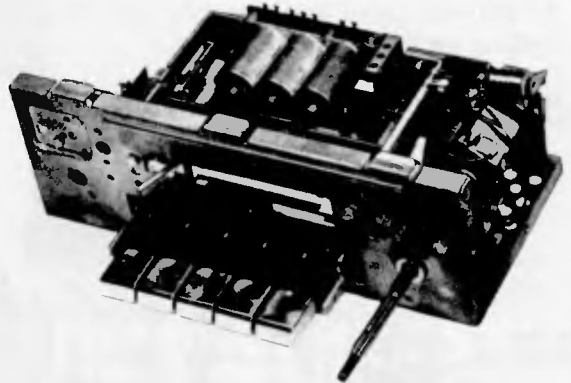

FIGURE 1. MODEL ST-162 SEARCH TUNER

contacts the planetary gear system, the planetary gear system rotates when the manual tuning shaft (21) is turned. Because the search selector has not been depressed, the control clutch does not engage the carrier gear. Under this condition the planetary gear system is allowed to rotate without turning the motor (E2 -see Figure 9).

PUSHBUTTON TUNING

This tuner is equipped with five pushbuttons which may be set up in any sequence to tune any radio station within the tuning range of the radio. To set the pushbuttons, the station is first tuned in with the manual tuning knob; this adjusts the angle of the treadle bar assembly (see Figure 3) to an angle corresponding to a radio station. The pushbutton is then unlocked by pulling it out; this actually unlocks the adjustable cam on the push arm. When the pushbutton is depressed, the cam is locked to the angle of the treadle bar assembly and remains at that angle until changed. Therefore, whenever a pushbutton is depressed it will return the treadle bar assembly to the angle to which the cam was set.

The power transfer is directly from the push arm to the treadle bar assembly (see Figure 4). When a pushbutton is depressed, the clutch release arm disengages the split gears and bushing assembly (7) from the clutch and disc assembly (4), allowing the treadle bar assembly to rotate without turning the manual tuning shaft (21). When the pushbutton is released the split gears and bushing assembly (7) and clutch and disc assembly (4) are engaged, holding the tuner on station.

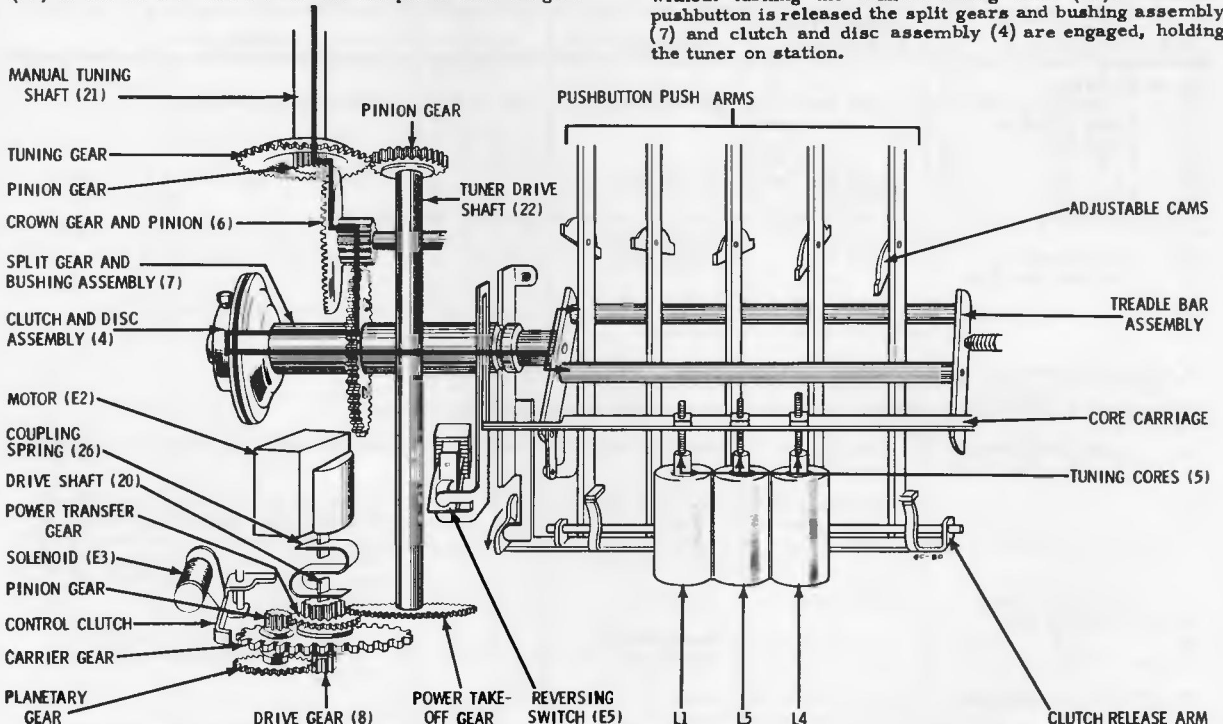

FIGURE 2. MANUAL TUNING

MOTOROLA Search Tuner Model ST-162
(Continued)

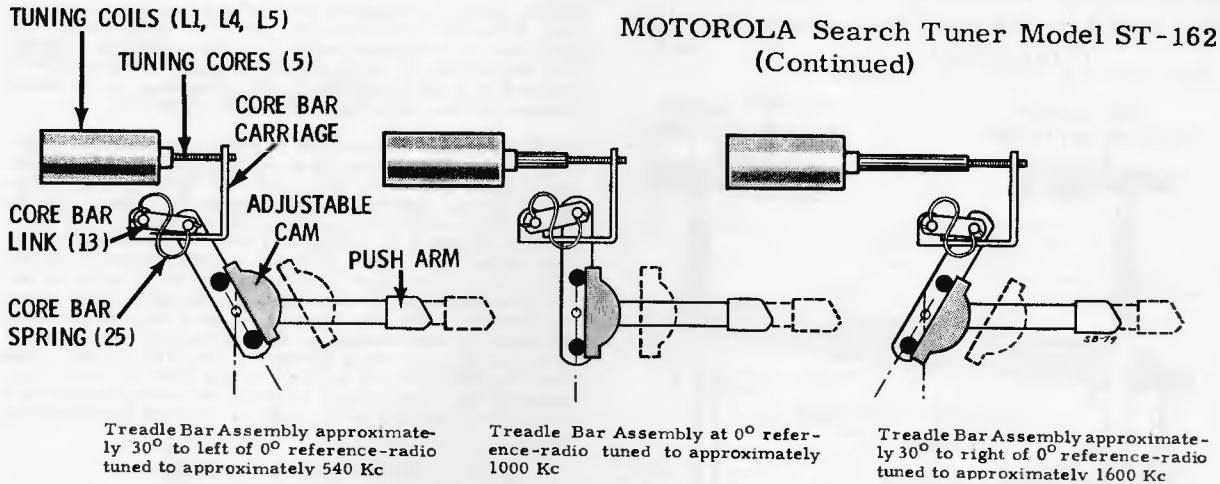

FIGURE 3. TREADLE BAR ASSEMBLY

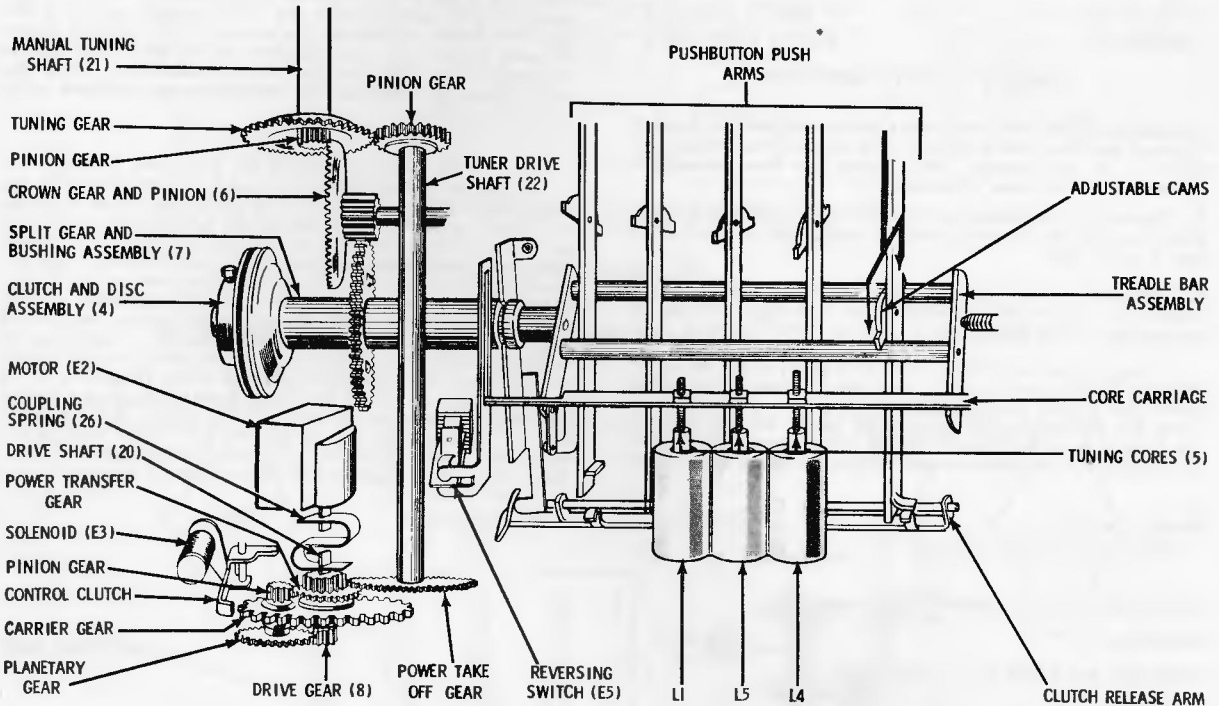

FIGURE 4. PUSHBUTTON TUNING

SEARCH TUNING

Search tuning provides a way of automatically tuning to the next radio station by merely depressing a search selector button. The search tuning mechanism can be operated by two search selector buttons marked "T" and "C"; the "T" (town) button for search tuning strong local stations and the "C" (country) for tuning weaker stations.

When a search selector button is depressed, the following occurs:

1. The sensitivity switch E6 is either opened or closed by the action of the sensitivity switching link (see Figure 5 and SENSITIVITY SWITCHING) and one of the search selector switches (E7 or E8) is momentarily closed.
2. With E7 or E8 momentarily closed the audio is muted and R34 is grounded (see Figure 7), which completes the relay (E4) circuit to ground. With the circuit complete, relay E4 becomes energized, grounding relay contacts A, B1, C and D, and ungrounding contact B2.

3. Contact A is connected to the output stage and grounding this contact mutes the output during search.

4. Contact B1 switches R28 across bias resistors R29, R30, and R33. This reduces the bias on the trigger tube. With the bias lowered, the relay section of the trigger tube conducts sufficient current to hold relay E4 energized after switch E7 or E8 is opened.

5. Contact B2 grounds the cathode resistor R13 of the RF and IF stages. While searching, when contact B2 is ungrounded, the bias of the RF and IF stages is determined by the position of switch E6 (see Figures 5 & 7). With switch E6 opened the bias is lowered while searching because the cathode circuit is completed to ground through the additional cathode resistor R15. With switch E6 closed the bias remains normal even while searching.

6. Contact C completes the motor (E2) circuit to ground, which starts the search mechanism operating. It will be noted that the motor is connected to a reversing switch which is operated by an actuator linked to the treadle bar

MOTOROLA Search Tuner Model ST-162
(Continued)

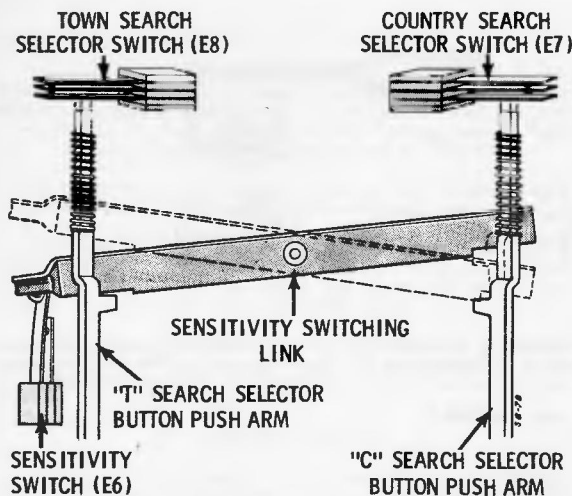

FIGURE 5. SWITCH OPERATIONS

assembly. When the treadle bar assembly reaches its end of travel position, the switch (E5) is tripped, reversing the direction of the motor. This allows the tuner to search radio stations in either direction.

7. Contact D completes the solenoid (E3) circuit to ground which causes the control clutch to engage the carrier gear (see Figure 10).

8. With the carrier gear engaged (because of the control clutch) the motor (E2) is allowed to transfer its power to the manual tuning shaft (21) as follows: (see Figure 6)

From the motor (E2) to the drive gear, from the drive gear to the planetary gear, from the planetary gear to the pinion gear, from the pinion gear to the power transfer gear, from the power transfer gear to the power take-off gear of the tuner drive shaft (22), from the tuner drive shaft (22) to the tuner drive shaft pinion gear, from the tuner drive shaft

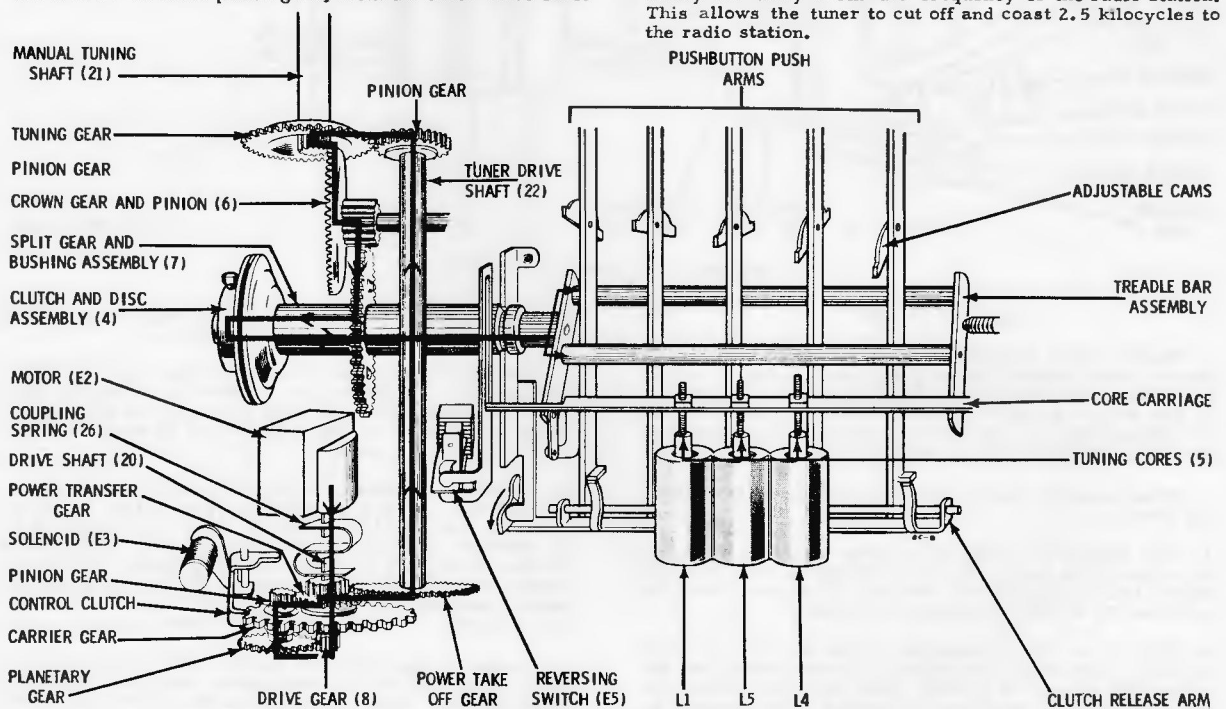

FIGURE 6. SEARCH TUNING

pinion gear to the tuning gear of the manual tuning shaft (21), from the manual tuning shaft (21) to the treadle bar assembly, as explained under MANUAL TUNING. NOTE: The pinion gear of the tuner drive shaft (22) is secured to the shaft by a slip clutch which prevents damage to the motor in case the tuner is stopped while searching.

9. As the tuner approaches a station, a combined signal (WC Figure 7) is developed at the grid of the detector section of the trigger tube, by the addition of the AVC (WA Figure 7) voltage and the IF (WB Figure 7) voltage. As the signal becomes more positive, the detector draws more current through R32. The plate side of R32 develops a negative pulse (WD Figure 7) which is sufficient to cut off the relay tube. With the relay tube cut off, the relay E4 is de-energized and the relay contacts are returned to their original position. With the contacts in their original position, the detector tube is also cut off because resistor R28 is no longer across the biasing resistors (R29, R30 & R33). This also de-energizes the solenoid of the control clutch, disengaging the carrier gear allowing the motor to coast to a stop. The sensitivity of the radio is returned to the normal level.

SENSITIVITY SWITCHING

The sensitivity of the radio is automatically changed when one of the search buttons is depressed. The "T" button lowers the sensitivity of the radio by opening switch E6. The "C" button increases the sensitivity by closing switch E6 (see Figure 5). The position of the switch E6 affects the sensitivity only when the radio is searching. When the tuner stops on a station the sensitivity is returned to its normal strength.

DETECTOR CIRCUIT OF TRIGGER TUBE

The detector circuit functions as a cut-off device for the relay tube. The coast distance of the tuner, after the relay E4 is de-energized, is approximately 2.5 kilocycles. Therefore, the relay tube must be cut off 2.5 kilocycles before the tuner reaches the frequency of a radio station. The detector tube can actually control the relay tube on the IF signal alone, but because of the difference of power between radio stations, the AVC voltage must control the cut-off point. The AVC voltage controls this by re-shaping the waveform (WC Figure 7) where necessary, so that the RF cut-off level is 2.5 kilocycles ahead of the frequency of the radio station. Figure 8 shows the addition of the AVC voltage to a weak station and to a strong station. It can be seen that in the combined RF signal, the RF cut-off level is 2.5 kilocycles away from the frequency of the radio station. This allows the tuner to cut off and coast 2.5 kilocycles to the radio station.

MOTOROLA Search Tuner
Model ST-162 (Continued)

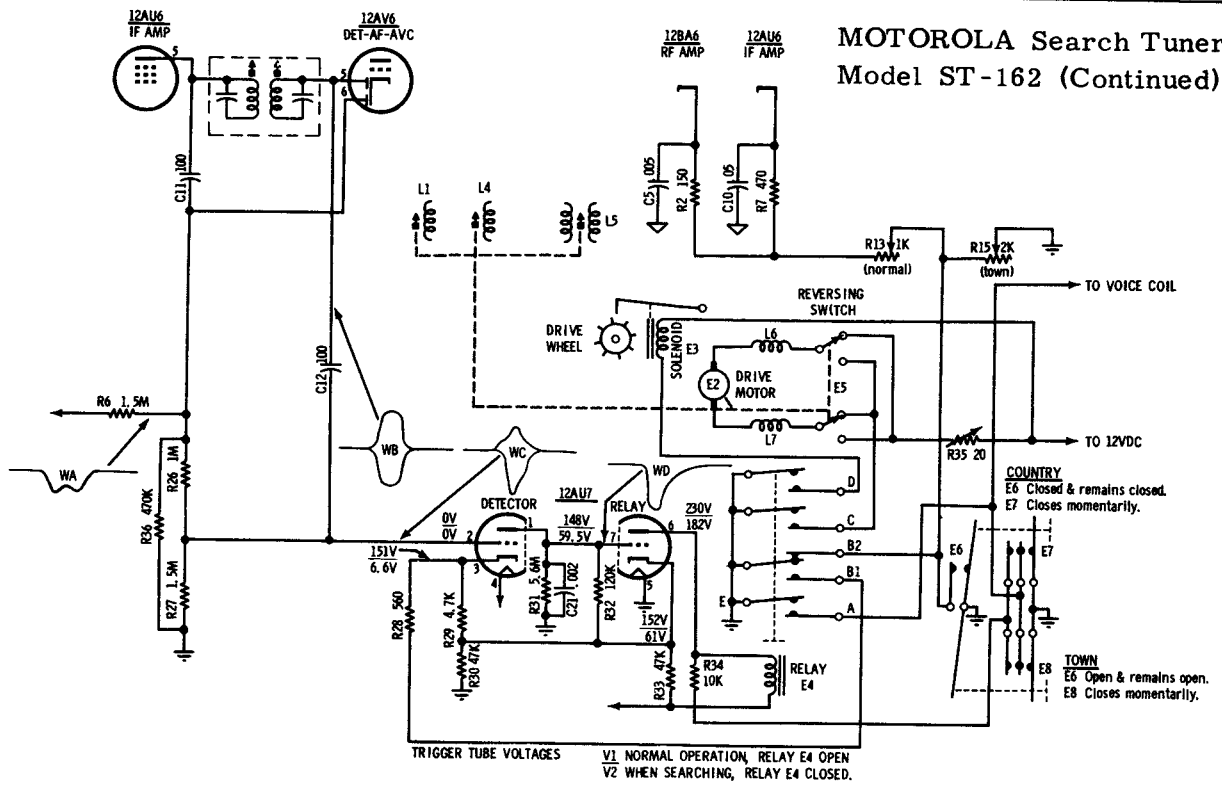

FIGURE 7. FUNCTIONAL SCHEMATIC

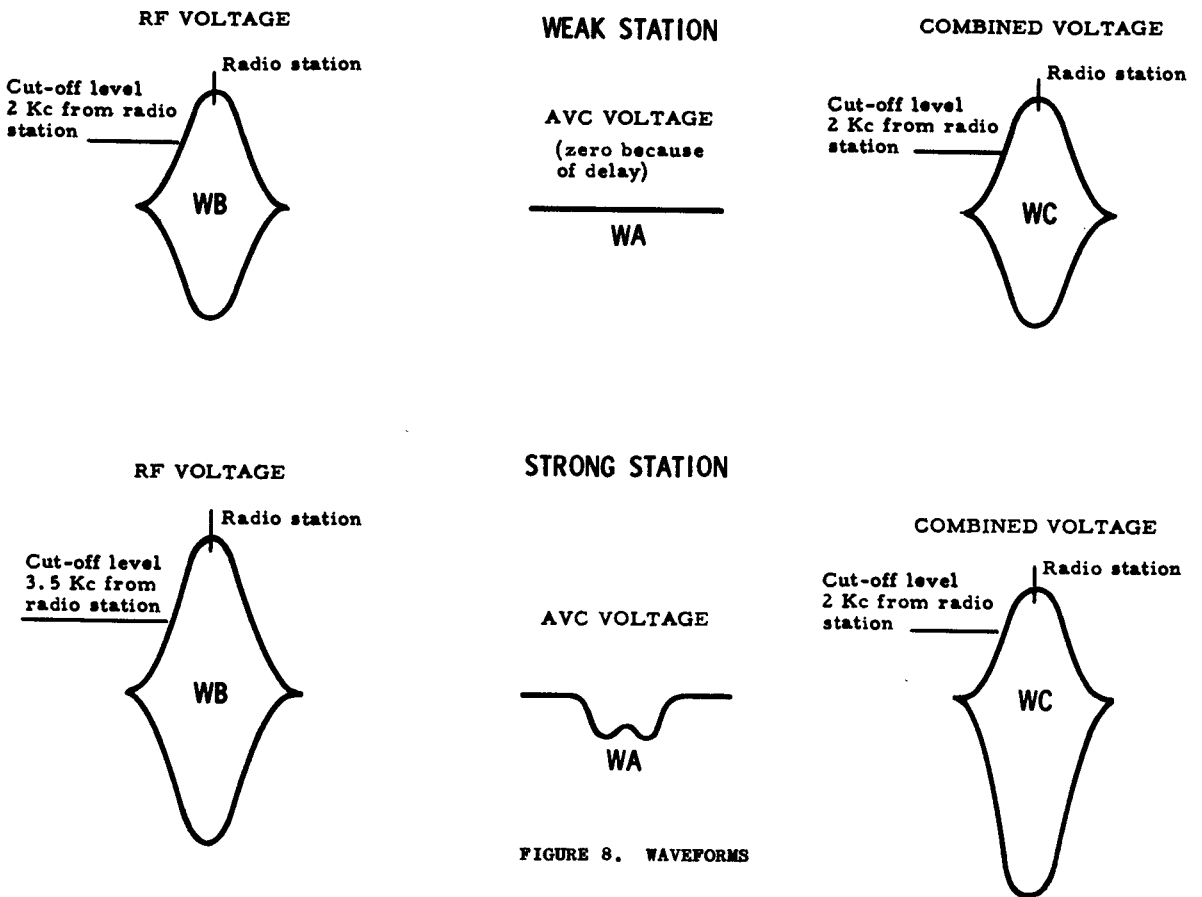

FIGURE 8. WAVEFORMS

MOTOROLA Search Tuner Model ST-162

(Continued)

PLANETARY GEAR SYSTEM

The planetary gear system functions as a switch to transfer the motor (E2) power to the manual tuning shaft (21) or to allow the manual tuning shaft (21) to rotate without turning the motor (E2). When the control clutch engages the carrier gear (see Figure 10), the power of the motor turns the manual tuning shaft (21) as explained under SEARCH TUNING and Figure 6. When the control clutch does not engage the carrier gear, the motor does not turn the manual tuning shaft (21), but allows the manual tuning shaft (21) to be turned without turning the motor.

ADJUSTMENTS

MOTOR SPEED

In series to the motor (E2) is a variable resistor R-35. This resistor adjusts the sweeping speed of the motor (E2). The resistor (R-35) should be adjusted with 14.4 volts at the input of the radio. Proper adjustment causes the motor to sweep across the dial scale in approximately 6 seconds. To check the sweep time, hold one of the search selector buttons down and check the time it takes the pointer to travel from one reversing point to the other.

CONTROL CLUTCH

When the control clutch is disengaged from the carrier gear, the clearance between the control clutch and the tip of the carrier gear teeth, shall be no more than .015. If adjustment is required, bend the control clutch adjusting lug until the above clearance is obtained. (See Figure 11).

MOTOR REVERSING SWITCH

There are two adjustments provided for the motor reversing switch (E5); one for the high frequency stop reversal and one for the low frequency stop reversal.

To adjust the high frequency reversing position proceed as follows: trip the reversing switch (E5), manually, toward the rear of the radio; with the manual tuning knob tune the radio until the core carriage reaches 1/64" away from the high frequency stop; adjust the high frequency adjusting cam to trip the reversing switch (E5). (See Figure 12).

To adjust the low frequency reversing position proceed as follows: trip the reversing switch (E5), manually, toward the front of the radio; with the manual tuning knob tune the radio until the core carriage reaches 1/64" away from the low frequency stop; adjust the low frequency adjusting cam to trip the reversing switch (E5). (See Figure 12).

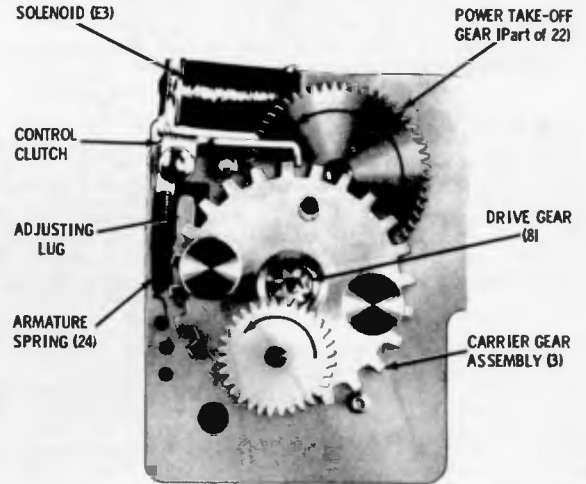

FIGURE 10. CLUTCH ENGAGED

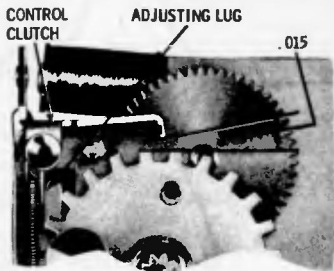

FIGURE 11. CONTROL CLUTCH ADJUSTMENT

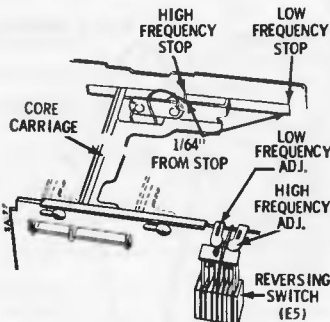

FIGURE 12. REVERSING SWITCH ADJUSTMENT

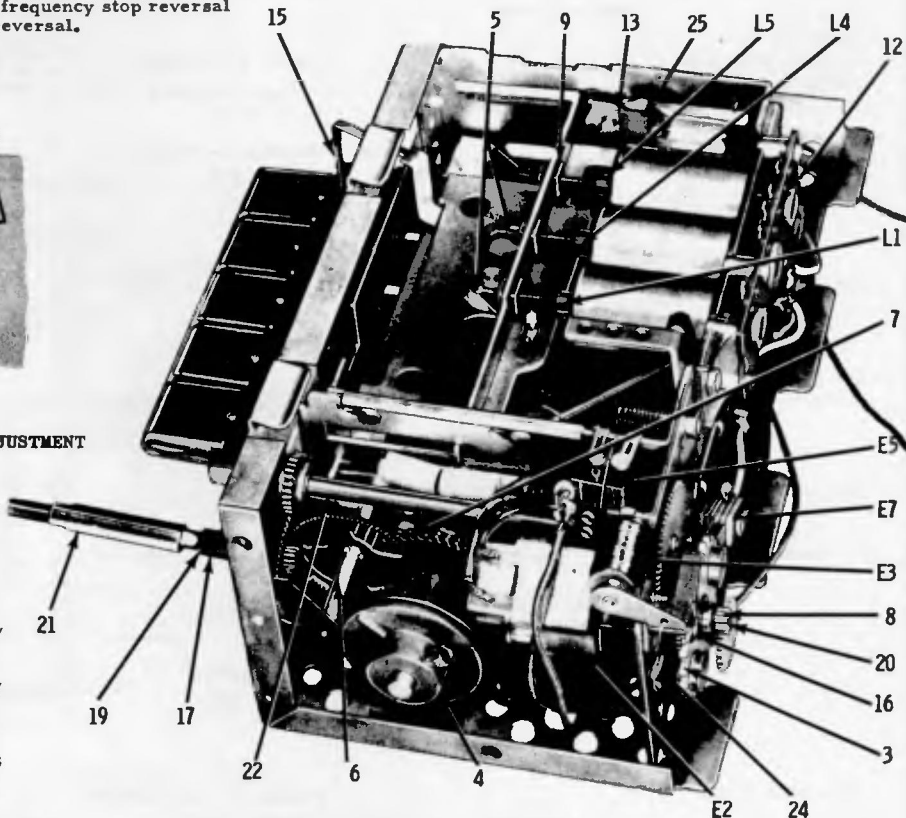

FIGURE 13. TUNER PARTS LOCATIONS

Packard-Bell

MODEL 10RP1 COMBINATION PHONO-RADIO

(Alignment Information is on the next page over.)

DC RESISTANCE MEASUREMENTS:

- L-1 or L-2, choke
0.2 ohms
- L-3, negligible
- L-4, I-F, FM
Pri: 1.4 ohms
Sec: 1.4 ohms

- L-5, I-F, AM
Pri: 16 ohms
Sec: 16 ohms
- L-6, I-F, FM
Pri: 1.4 ohms
Sec: 1.4 ohms

- L-7, I-F, AM
Pri: 16 ohms
Sec: 16 ohms
- L-8, Roto detector
Pri: 2.5 ohms
Sec: 0.2 ohms

- L-9, negligible
- L-10, Ferroloop
1.6 ohms
- L-11, Oscillator, AM
Pri: 8.5 ohms
Sec: 0.6 ohms

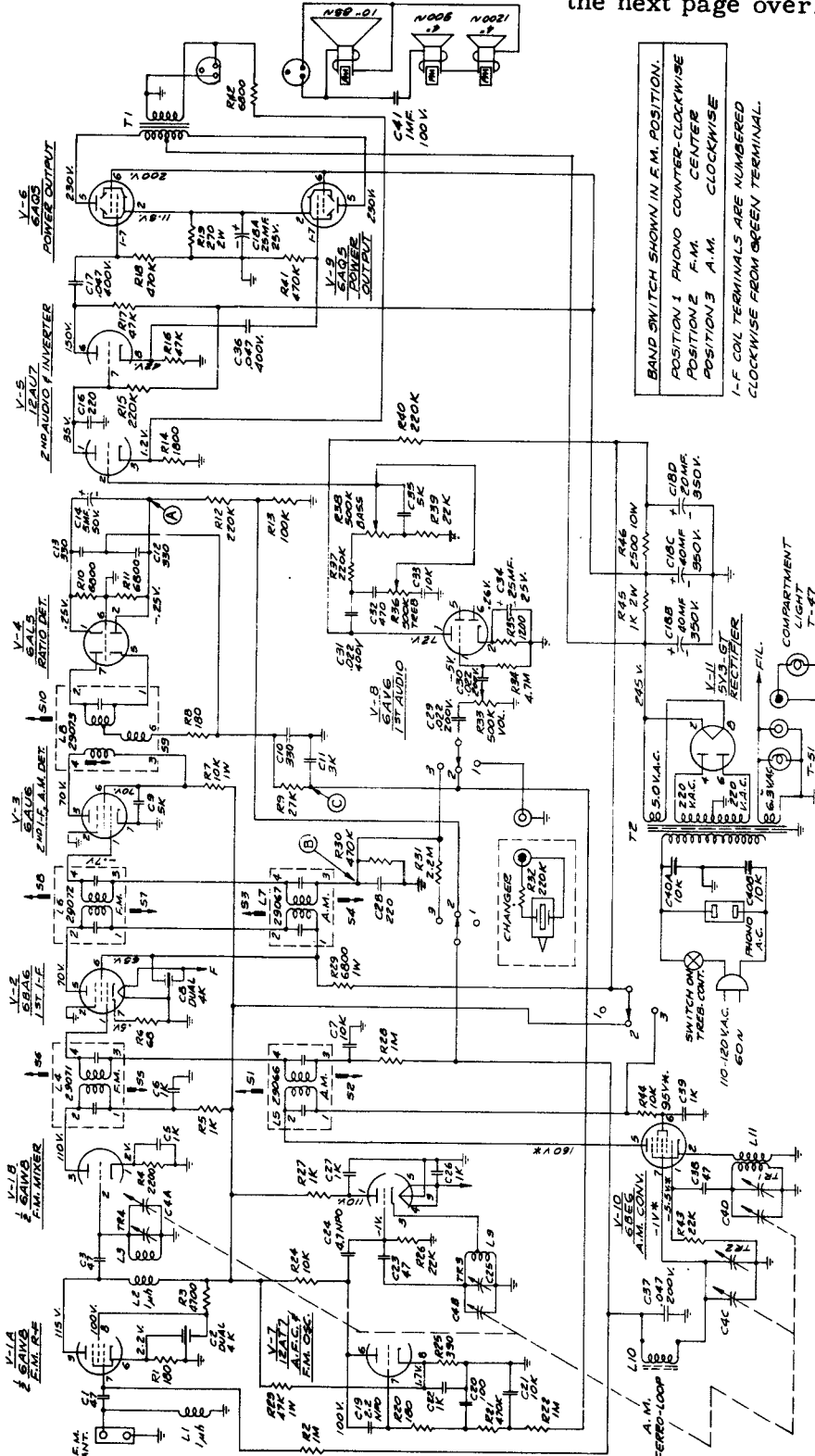

BAND SWITCH SHOWN IN F.M. POSITION.
POSITION 1 PHONO COUNTER-CLOCKWISE
POSITION 2 F.M. CENTER
POSITION 3 A.M. CLOCKWISE
I-F COIL TERMINALS ARE NUMBERED
CLOCKWISE FROM GREEN TERMINAL.

*NOTE: All voltages taken with band switch in F-M position EXCEPT voltages on V-10 which are starred. These are A-M readings.

Schematic Diagram, Model 10RP1

PACKARD - BELL Model 10RP1 Combination (Continued)

ALIGNMENT CHART

Equipment Required: Signal generator, AM; two 150 ohm 1/2 watt resistors; one .01 mfd, 600 volt paper capacitor.

DUMMY ANTENNA	SIGNAL GENERATOR CONNECTION	SIGNAL GENERATOR FREQUENCY	RADIO RECEIVER DIAL SETTING	VTVM CONNECTION	ADJUST	NOTES
ALIGNMENT OF I-F, AM SECTION						
1. .01 mfd in series with gen. output	Pin 7 of V-10 (grid 3, 6BE6)	455 kc, modulated with 400 cps	Low frequency end point	Negative to pt. "B," positive to ground	S-1, S-2, S-3, & S-4 for MAX	Reduce signal generator output to lowest usable level
ALIGNMENT OF R-F, AM SECTION						
2. None	Loose-couple to loop	1620 kc, modulated with 400 cps	High frequency end point	Ditto	TR-1 for MAX	None
3. None	Ditto	1500 kc, modulated with 400 cps	Tune in signal	Ditto	TR-2 for MAX	None
ALIGNMENT OF I-F, FM SECTION						
4. .01 mfd in series with gen. output	Pin 2 of V-1 (grid, triode section, 6AWB)	10.7 mc, unmodulated	Low frequency end point	Ditto	S-5, S-6, S-7, & S-8 for MAX	Reduce signal generator output to less than one volt at pt. "B"
5. Ditto	Ditto	Ditto	Ditto	Negative to pt. "A," positive to ground	S-9 for MAX	None
6. Ditto	Ditto	Ditto	Ditto	Negative to pt. "C," positive to ground	S-10 for ZERO	A plus or minus reading will be obtained on each side of setting.
ALIGNMENT OF R-F, FM SECTION						
7. 150 ohms in each lead	FM antenna terminal	106 mc, unmodulated	106 mc	Negative to pt. "A," positive to ground	TR-3 for MAX	None
8. Ditto	Ditto	Ditto	Ditto	Ditto	TR-4 for MAX	None
9. Ditto	Ditto	92 mc, unmodulated	92 mc	Ditto	Compress or expand coil L-9 for MAX VTVM reading	
10. Ditto	Ditto	Ditto	Ditto	Ditto	Compress or expand coil L-3 for MAX VTVM reading	
11. REPEAT STEPS 7 THRU 10 UNTIL NO FURTHER INCREASE IN VTVM READING OCCURS.						

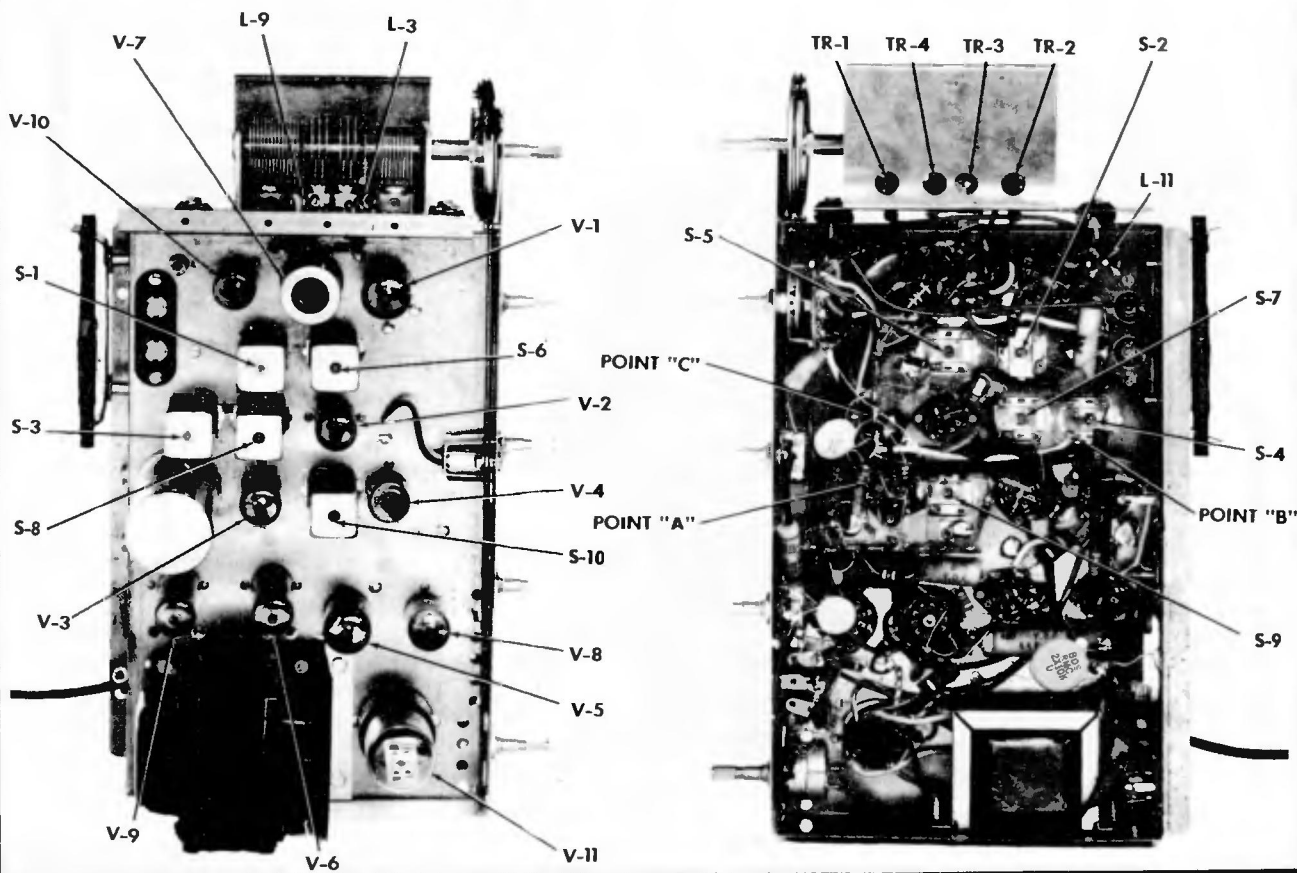

PHILCO

**D-592, D-593, D-595, D-598, D-727,
D-728, D-730 and D-736**

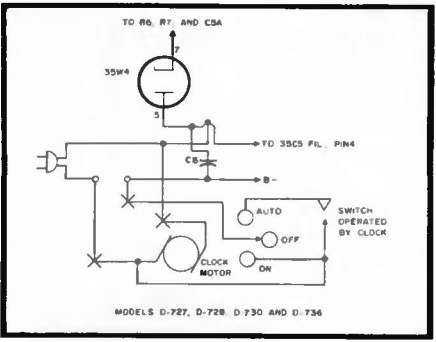
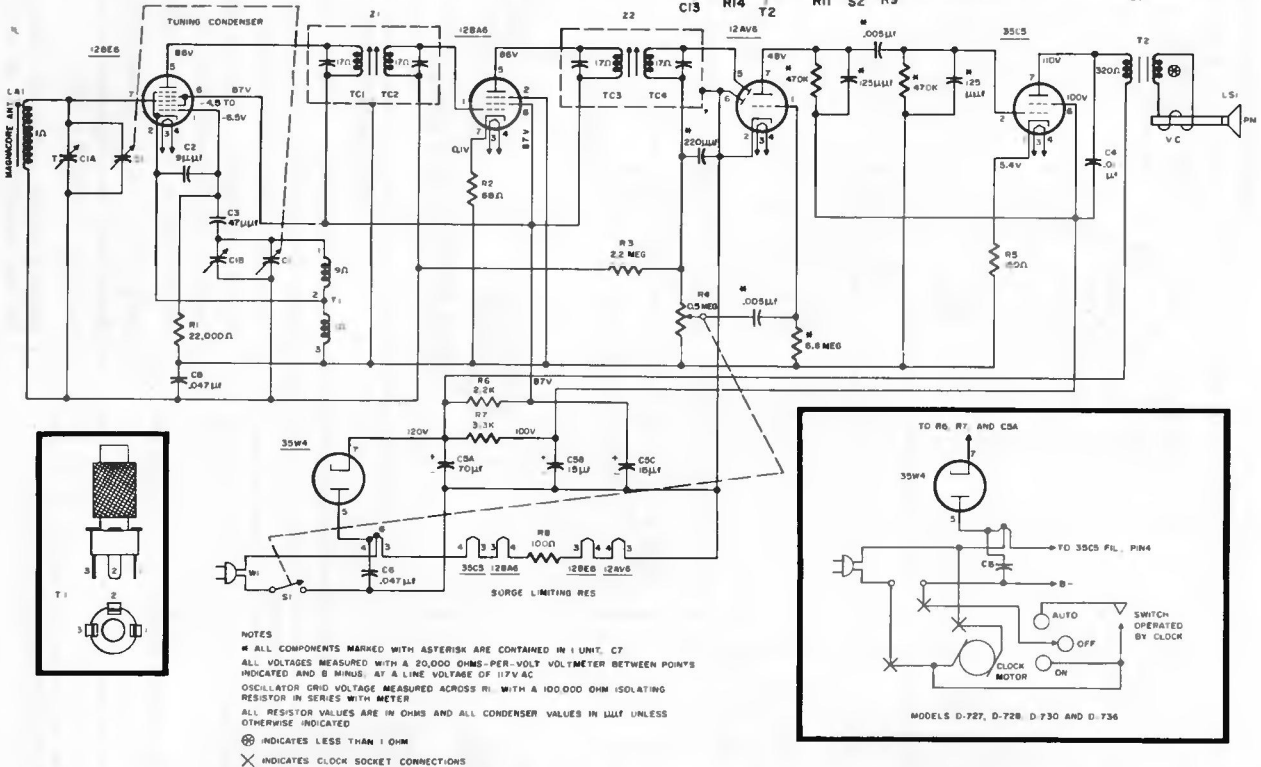
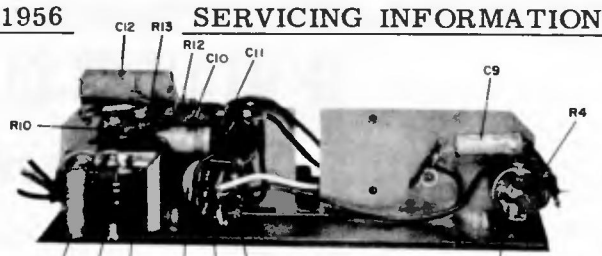

Above is an exact circuit for Models D-592, D-593, and D-595. For differences in Models D-727, D-728, D-730, and D-736, refer to clock circuit in insert above. Model D-598 uses a neon lamp as an off-on indicator, and incorporates a phono-input jack, a variable tone control, and a radio-phono switch.

ALIGNMENT PROCEDURE

RADIO CONTROLS — Set volume control to maximum. Set tuning control as indicated in chart.

OUTPUT METER — Connect across voice-coil terminals.

SIGNAL GENERATOR — Connect generator and set frequency as indicated in chart. Use modulated output.

OUTPUT LEVEL — During alignment, adjust signal-generator output to hold output-meter reading below .5 volts.

ALIGNMENT CHART

STEP	SIGNAL GENERATOR		RADIO		ADJUST
	CONNECTION TO RADIO	DIAL SETTING	DIAL SETTING	SPECIAL INSTRUCTIONS	
1	Ground lead to B-; output lead through a .1 mf. condenser to grid (pin 7) of 12BE6.	455 KC	Tuning gang fully open.	Adjust tuning cores, in order given, for maximum output. TC3 and TC4 are located at top of transformers.	TC4—2nd i-f sec. TC3—2nd i-f pri. TC2—1st i-f sec. TC1—1st i-f pri.
2	Radiating loop (See note below).	1620 KC	1620 KC *	Adjust trimmer for maximum output.	C1-B—osc.
3	Same as Step 2.	1500 KC	1500 KC	Adjust trimmer for maximum output.	C1-A—aerial

NOTE: Make up a 6-8 turn, 6 inch diameter loop from insulated wire, connect to signal-generator leads, and place near radio loop.

* For proper adjustment of the oscillator trimmer, fully open the tuning gang and insert a .006 inch non-metallic shim between the heel of the rotor and the top of the stator plates. Close the tuning gang sufficiently to hold the shim in place, and then remove the shim without disturbing the gang setting.

PHILCO

D-597, D-725, D-734, D-737 and D-738

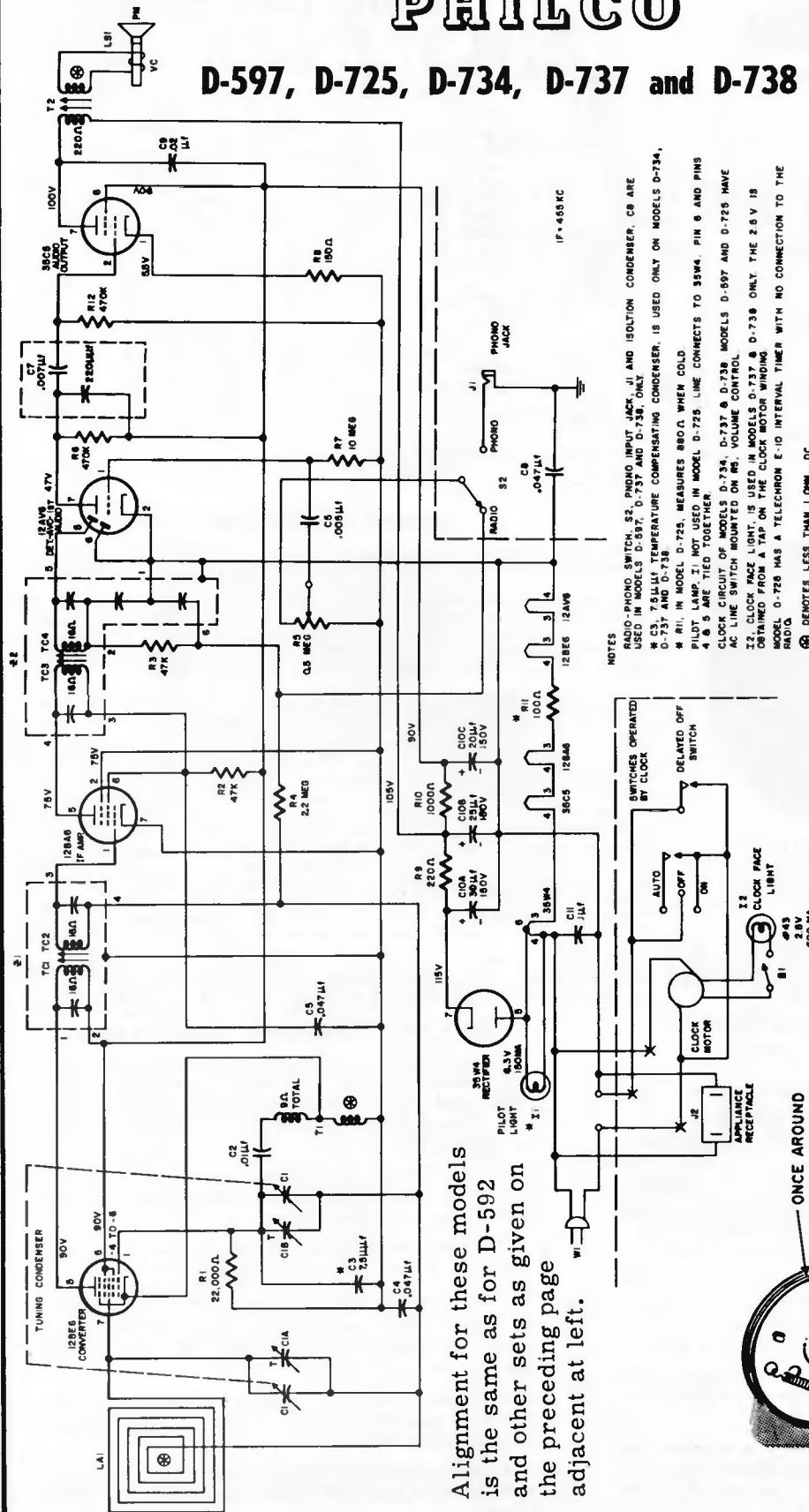

Alignment for these models is the same as for D-592 and other sets as given on the preceding page adjacent at left.

NOTES
 RADIO-PHONO SWITCH, S2, PHONO INPUT JACK, J1 AND SOLUTION CONDENSER, C8 ARE USED IN MODELS D-597, D-737 AND D-738, ONLY
 * C3, 750µMF TEMPERATURE COMPENSATING CONDENSER, IS USED ONLY ON MODELS D-734, D-737 AND D-738
 * R11, IN MODEL D-725, MEASURES 880Ω WHEN COLD
 P1, IN MODEL D-725, IS USED IN MODELS D-597 AND D-725 HAVE 4 & 5 ARE TIED TOGETHER.
 CLOCK CIRCUIT OF MODELS D-734, D-737 & D-738 MODELS D-597 AND D-725 HAVE AC LINE SWITCH MOUNTED ON R8, VOLUME CONTROL
 C12, CLOCK FACE LIGHT, IS USED IN MODELS D-737 & D-738 ONLY THE 2.0 V IS OBTAINED FROM A TAP ON THE CLOCK MOTOR WINDING
 MODEL D-725 HAS A TELECHRON E-10 INTERVAL TIMER WITH NO CONNECTION TO THE RADIO
 Ⓢ DENOTES LESS THAN 1 OHM, DC

Schematic Diagram — Models D-597, D-725, D-734, D-737 and D-738

Chassis Removal — Model D-597

The following six steps should be performed, in order, to remove the chassis from the cabinet.

1. Remove the two control knobs.
2. Remove the Phillips head screw from the dial scale.
3. Carefully pry dial scale out from bottom.
4. Remove the pointer.
5. Remove the two back mounting screws.
6. Remove the three drive screws from the cabinet bottom.

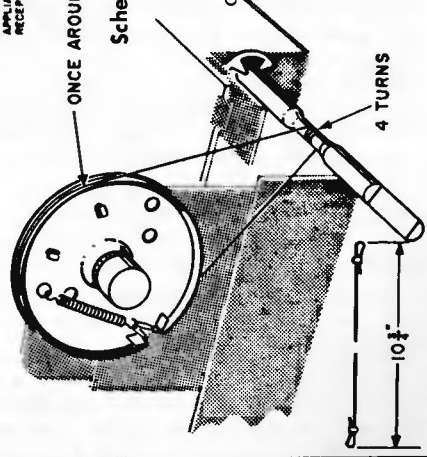

Dial Cord Strings, — Model D-597

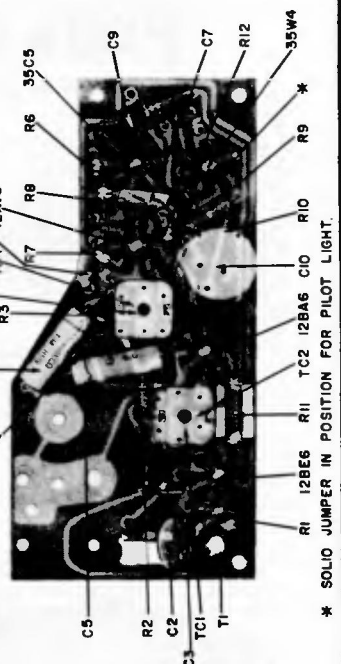

* SOLID JUMPER IN POSITION FOR PILOT LIGHT.

PHILCO

MODELS TPA-1, TPA-2

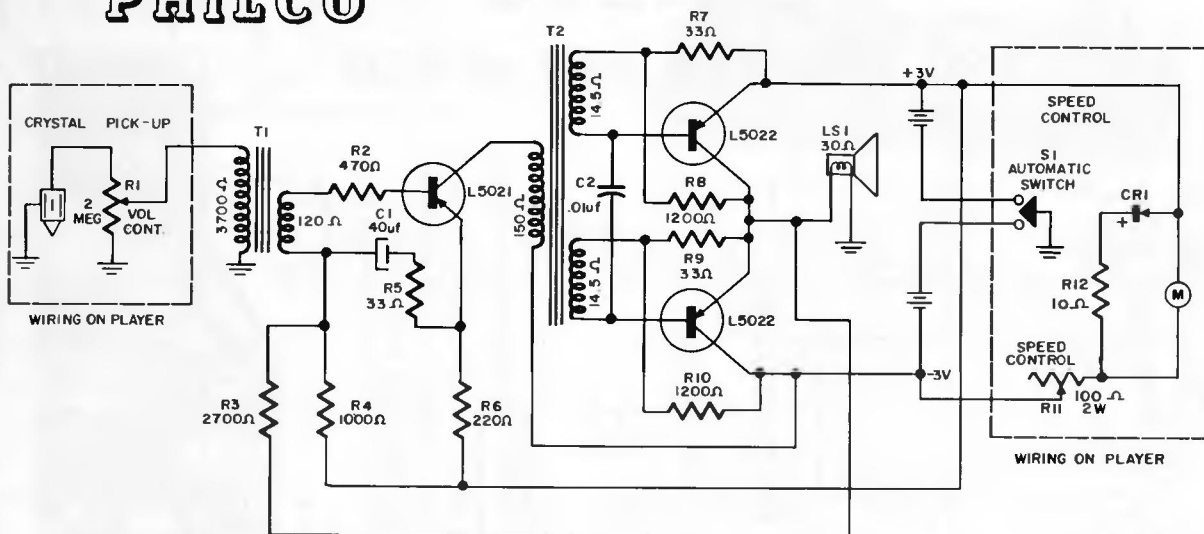

CIRCUIT DESCRIPTION

The circuit consists of a transistor amplifier stage feeding two transistors in a push-pull class B output stage. The printed wiring panel serves as the chassis.

The transistors employed in this amplifier are alloy-junction types L5021 and L5022. The alloy or fused-junction type is used in view of the power requirements necessary to drive the speaker. The speaker voice coil, of 30 ohms dc resistance, is the output load. Transformer coupling is employed between stages. The three transistors are base fed in a common emitter circuit.

The M-32 and M-32A, 45 RPM, record players incorporate a 4.0 volt, dc motor in rim drive, a crystal pickup cartridge and an automatic on-off switch.

The switch operates as follows: Normally, the motor and amplifier are off when the tone arm is in the rest post. The unit is turned on by lifting the tone arm clear of the rest post and swinging out or away from the turntable. This turn on is accomplished by the wire, mounted on the trip plate assembly, pushing the stud, part of the toggle plate assy. between the leaves of the trip switch, thus completing the circuit. This stud remains in the trip switch until the record is completed. As the tone arm moves inward in the record's trip groove, the long ear of the trip plate assembly disengages the toggle plate stud from the switch thus turning the unit off. The tone arm may now be picked up and returned to the rest post with the set remaining off. This switching method is designed to conserve battery life as the unit is only on during the actual playing of a record. This is possible only because the transistors require no warm-up.

The output of the crystal pickup is coupled to the input stage by a step-down transformer. This matches the high crystal impedance with the relatively low input impedance of the L5021 transistor.

SERVICING TRANSISTOR PRINTED PANEL

1. Turn the unit on and, with a stroboscope on the turntable, adjust the speed control for 45 rpm. If proper turntable speed can be maintained, there is sufficient voltage (4.0 volts) for amplifier operation with but a slight decrease in power output.
2. Using a test record, of known characteristics, check the wave form appearing across the volume control (R1) for both voltage and signal quality.
3. Place oscilloscope leads across secondary of input transformer (T1) and check voltage and quality of signal.
4. Check speaker (LS1) for open voice coil or other troubles.
5. If trouble is still present, check signal wave form across primary of interstage transformer (T2). If trouble is indicated replace L5021 transistor.
6. Check signal across each secondary winding of T2. Poor or missing wave form at either secondary indicates a faulty interstage transformer.
7. Connect oscilloscope across the speaker voice coil, check wave form and replace the L5022 output transistors one at a time.



MODEL TPA-2

Tone arm Adjustments

1. The tone arm stanchion should be so located that the needle will Set Down at 1-5/8" ± 1/32" radius from turntable center for the arms innermost position.
2. Needle Pressure should be between 8 and 10 grams when the arm is parallel. To adjust, bend the vertical member of the support assembly, (the rear anchor of the needle pressure spring). Forward, to relax the needle pressure spring, will increase needle pressure. Toward the rear, to increase the spring tension, will decrease the needle pressure.
3. Horizontal tone arm friction should not be more than 1 1/2 grams at any point throughout its excursion.
4. Vertical tone arm friction should not exceed 1 1/2 grams. Vertical friction is measured as follows: Raise front end of tone arm with gram scale so that needle point is approx. 3/4" above the mounting plate. Take the reading. Then lower the tone arm 3/16" and again take a reading. One half of the difference of these readings is the vertical friction.
5. The pivot points of the hinge pin in the tone arm shell should be lubricated with a drop of oil, SAE 20. The bearing surface between the tone arm stanchion and the support assembly should have a light coating of motor cup grease.
6. The crystal cartridge leads must not interfere with the needle pressure spring nor the free vertical and horizontal movement of the tone arm.
7. Crystal sensitivity, measured across a 1 megohm load with a VTVM, shall be at least 1.5 volts RMS at 1000 cycles with needle tracking outside grooves of a standard 45 rpm test record.



RCA VICTOR

Automatic Record Player MODEL 6-EY-2 Chassis No. RS-136J

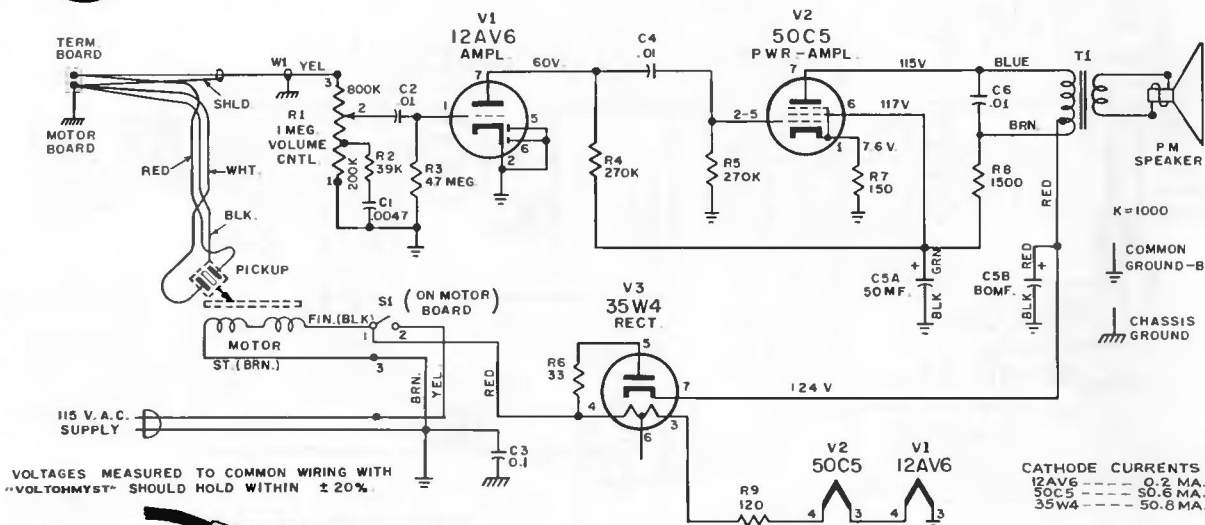

VOLTAGES MEASURED TO COMMON WIRING WITH "VOLTOHMYST" SHOULD HOLD WITHIN $\pm 20\%$

CATHODE CURRENTS
12AV6 ----- 0.2 MA.
50C5 ----- 50.6 MA.
35W4 ----- 50.8 MA.

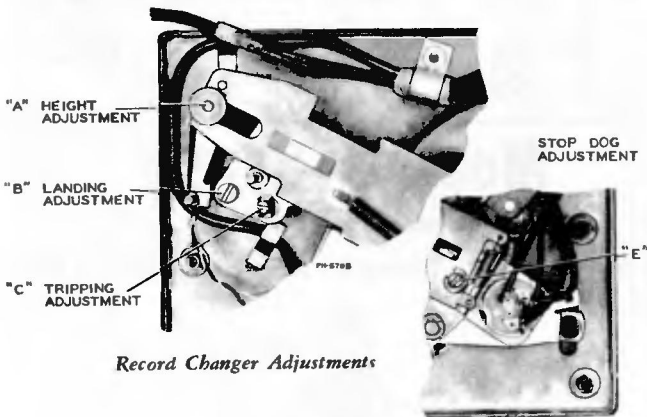

Record Changer Adjustments

Pickup Height Adjustment

Adjust knurled nut (A) until the distance (during change cycle) between the top of the turntable and the stylus point is approximately $1\frac{1}{8}$ ".

Pickup Landing Adjustment

Adjust the screw driver landing adjustment stud "B" so the stylus lands $2\frac{3}{8}$ " $\pm 1/64$ " from the side of the center post.

Tripping Adjustment

Adjust the eccentric tripping stud (C) until the mechanism trips when the stylus is $1\frac{9}{32}$ " from the side of the center post.

Stop Dog Adjustment

Turn the eccentric screw (E) until the record drops to the turntable without striking the pickup arm.

RCA VICTOR

Model 6-EY-1

Chassis No. RS-138S

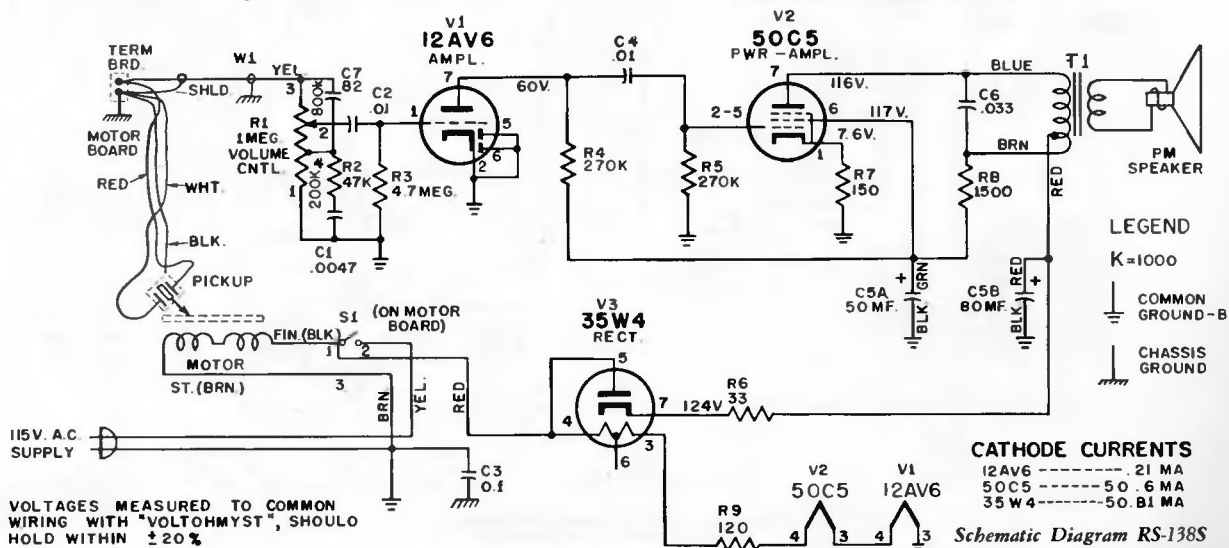

VOLTAGES MEASURED TO COMMON WIRING WITH "VOLTOHMYST", SHOULD HOLD WITHIN $\pm 20\%$

CATHODE CURRENTS
12AV6 ----- 21 MA.
50C5 ----- 50.6 MA.
35W4 ----- 50.81 MA.

Schematic Diagram RS-138S



RCA VICTOR

Model 6-EY-15

Chassis No. RS-138U

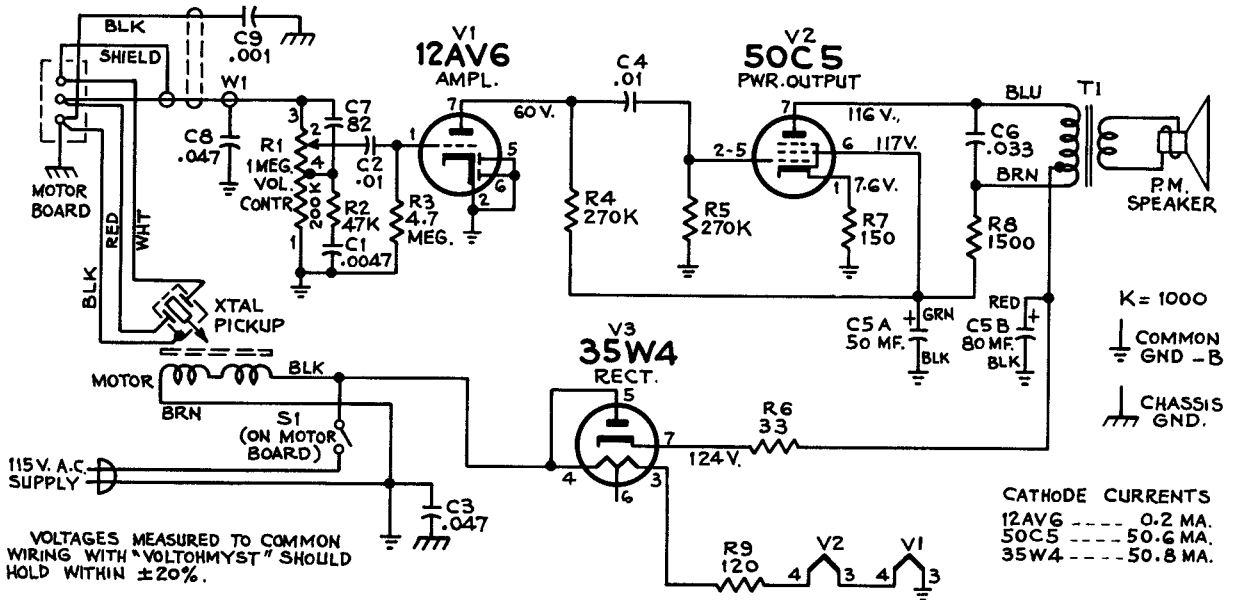

RCA VICTOR

MODEL 6-HF-5

Chassis No. RS-150

Model 7-HP-1, Chassis RS-150C, is similar.

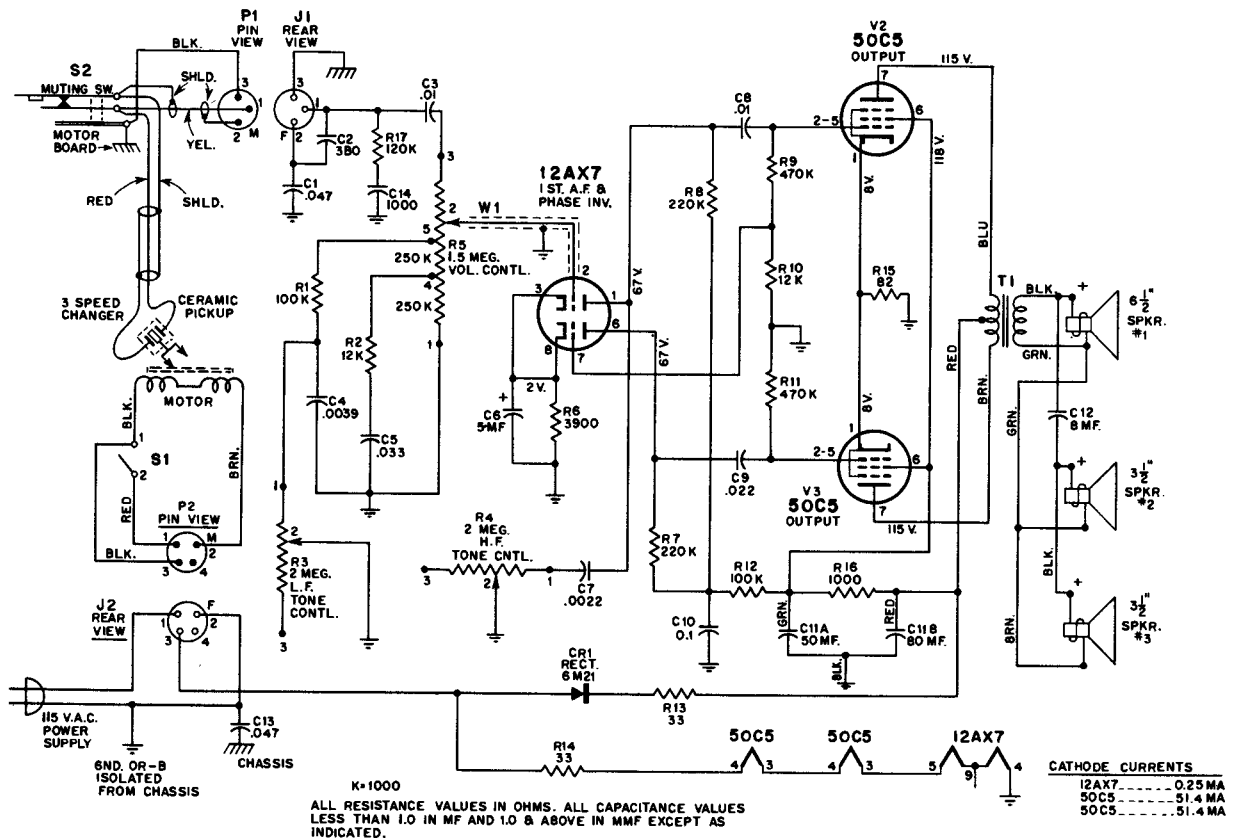

RCA MODEL 6-HF-4

Chassis No. RS-146C

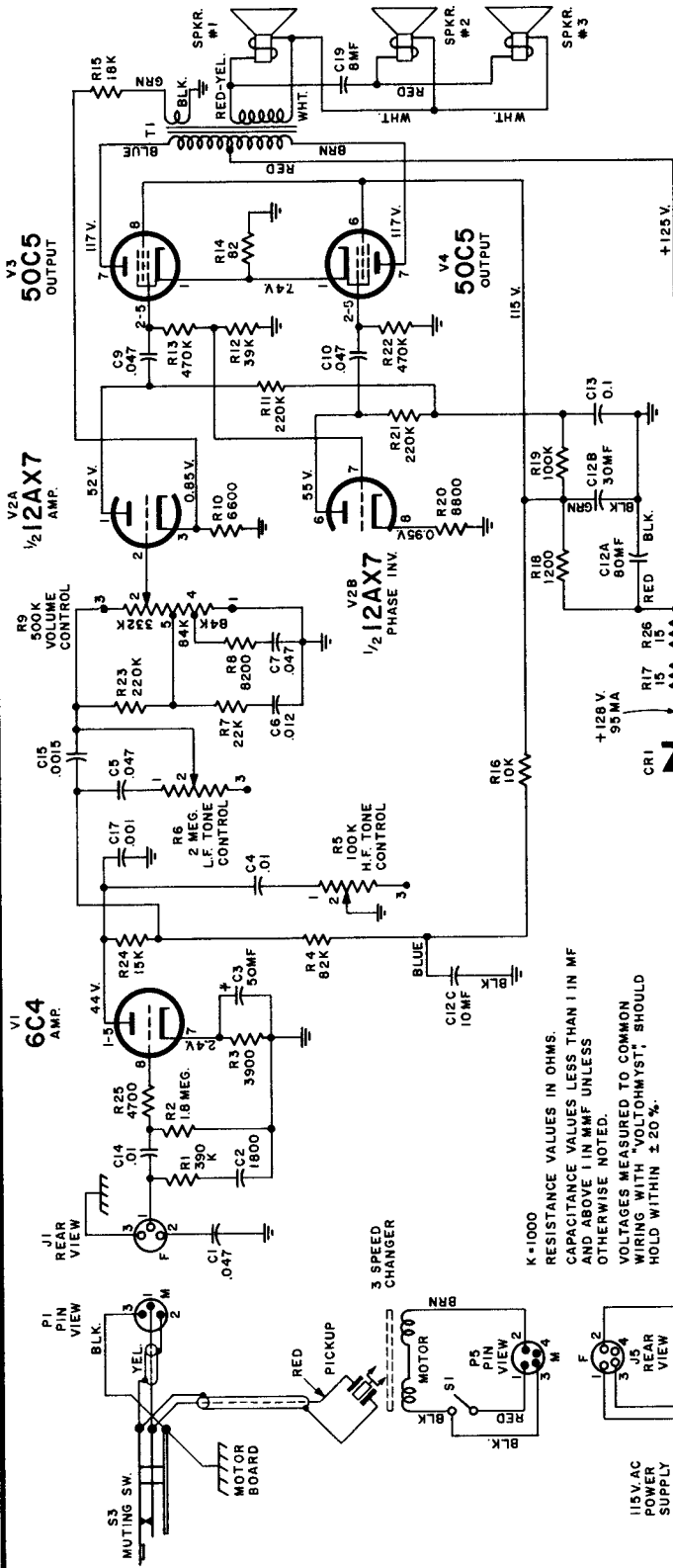

CRITICAL LEAD DRESS

1. Dress all capacitors except C4 and C5 against chassis.
2. Dress R17 at least 1/2" away from C11 and C12.
3. Dress all leads away from R18.
4. Keep all leads on R1, R2, C2, and C14 as short as possible.
5. Dress all filament wiring against chassis.

STYLUS REPLACEMENT

The dual stylus is held in position by a spring clamp. To remove stylus, simply hold pickup sideways and pull spring clamp away from stylus and allow it to drop out. When inserting stylus, be certain that the small diameter rod holding the styli rests in the notch of the drive arm connecting to the cartridge element.

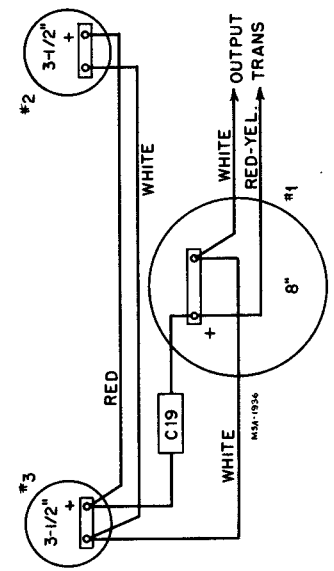

Speaker Connection Diagram

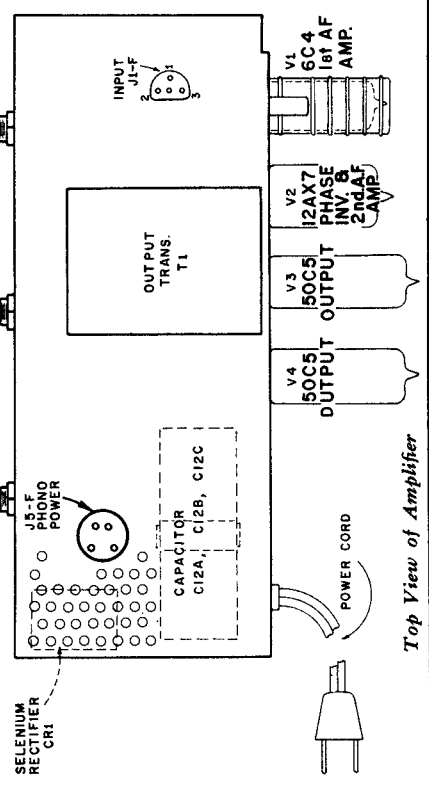

Top View of Amplifier

RCA VICTOR

MODEL 6-RD-3

Chassis No. RS-150B
Record Player Mechanism No. RP-200-1

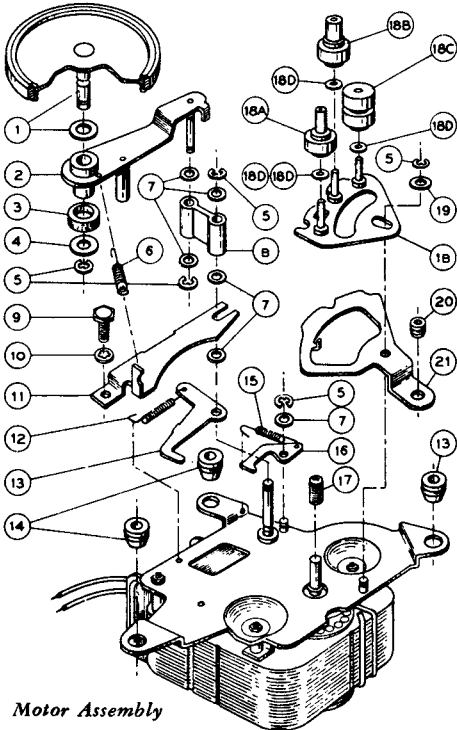

Motor Assembly

ALL RESISTANCE VALUES IN OHMS. ALL CAPACITANCE VALUES LESS THAN 1.0 IN MF AND 1.0 μ ABOVE IN MMF EXCEPT AS INDICATED.

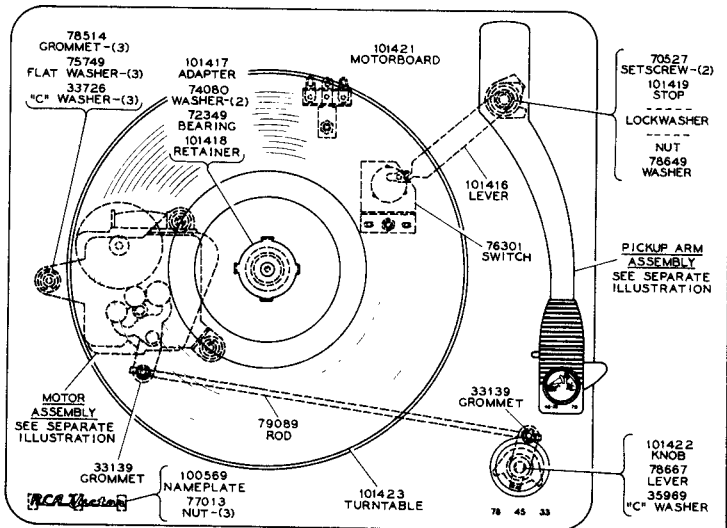

Motorboard Assembly

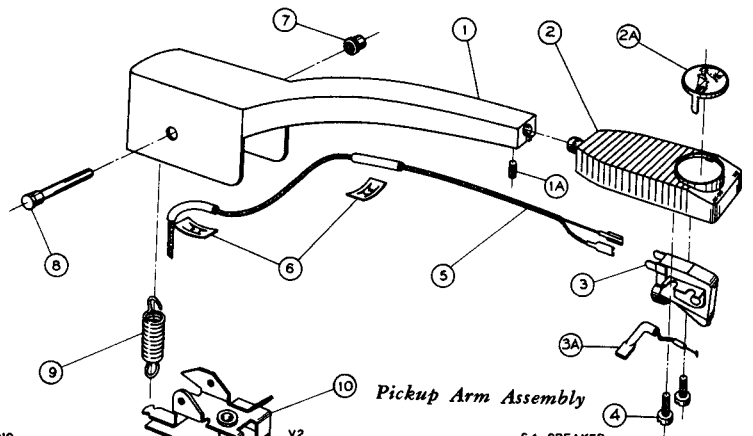

Pickup Arm Assembly

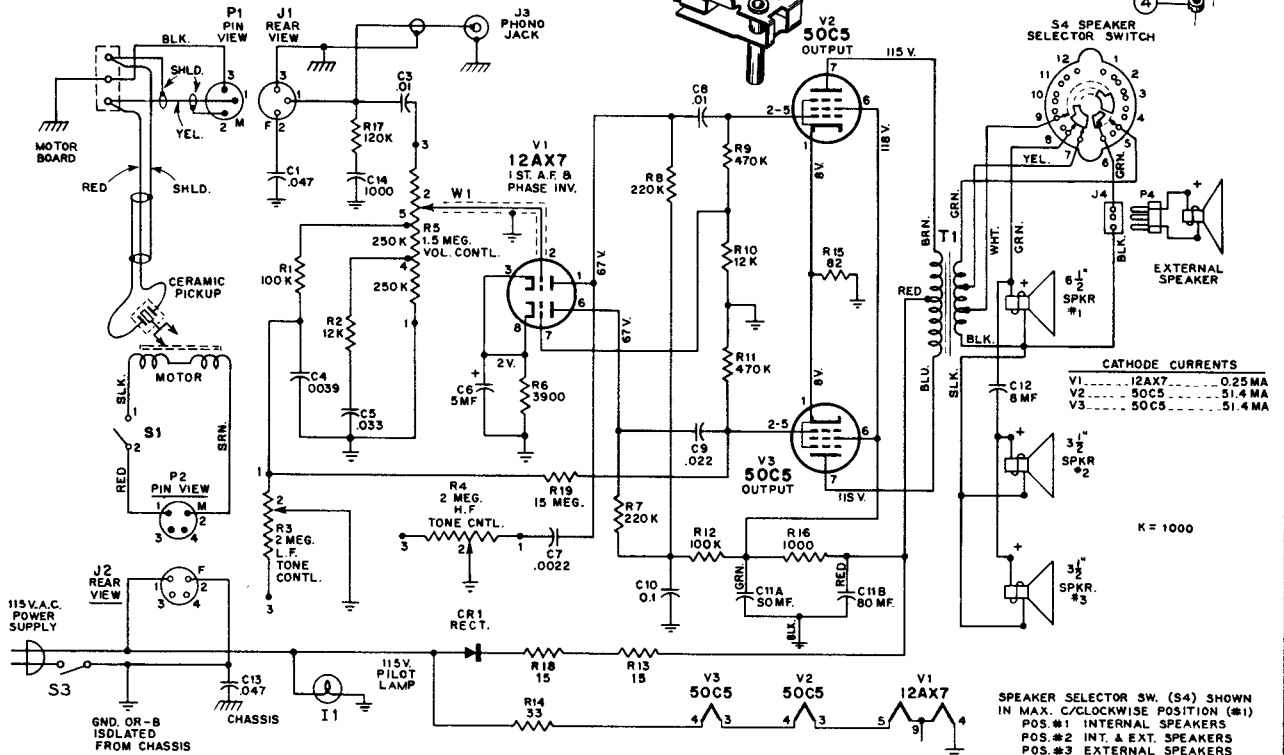

RCA VICTOR

6-EMP-1A, 6-EMP-1B

Chassis No. RS-152

RCA Victor Models 6-EY-3A, 6-EY-3B, Chassis RS-152A, are similar.

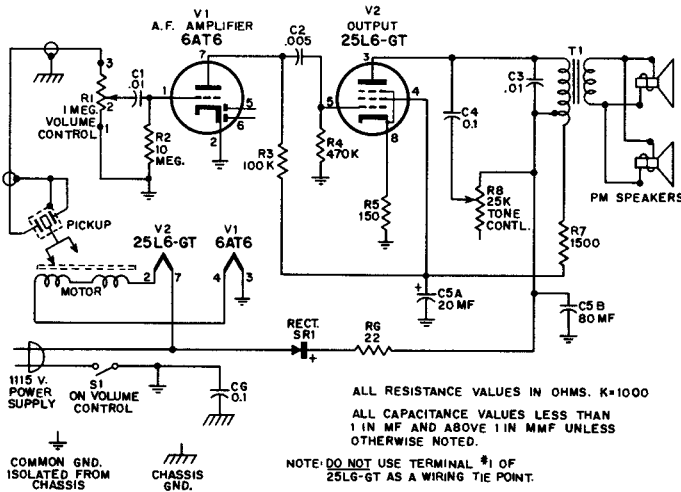

OPERATION

Remove metal Needle Guard from the Tone Arm. Turn POWER-VOLUME knob clockwise about one-half turn. Allow brief warm-up.

Move SPEED CONTROL lever to "33," "45," or "78" position for correct Turntable Speed.

Place record over correct Spindle onto Turntable.

Turn NEEDLE SELECTOR to "33-45" before playing 33 $\frac{1}{2}$ or 45 r.p.m. records; to "78" before playing 78 r.p.m. records.

Set Tone Arm needle at start of record; adjust VOLUME and TONE as desired.

IMPORTANT

The speed selector lever must be kept in the maximum clockwise position (adjacent to "78" position) when the instrument is not in use. Failure to do this will result in deformation of the idler wheel tire.

RCA VICTOR

6-EMP-2A, 6-EMP-2B

Chassis No. RS-153

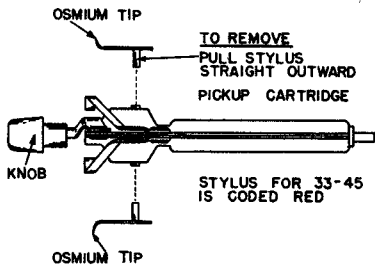
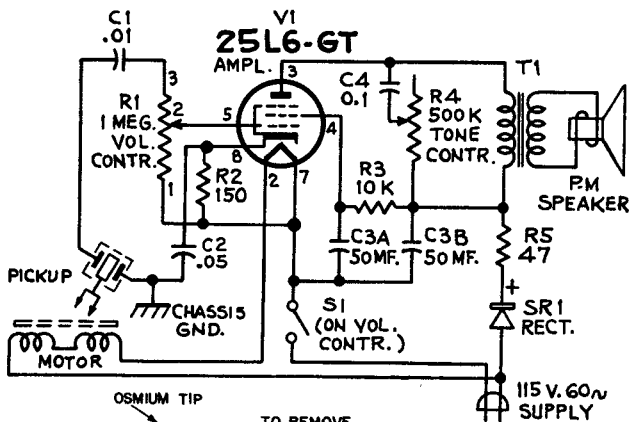

STYLUS REMOVAL

Each stylus is mounted on a short pin which fits into a socket on the pickup. To remove a stylus, pull straight outward away from pickup; it is held in place only by pressure fit.

RCA VICTOR

Automatic Record Player MODEL 7-EY-1 Series

Chassis No. RS-155
Record Changer No. RP-190D-1

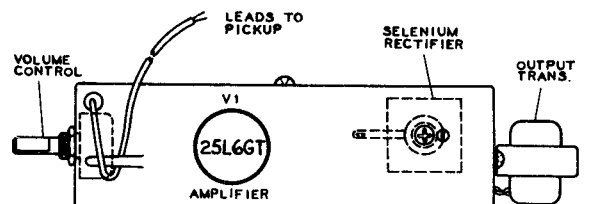
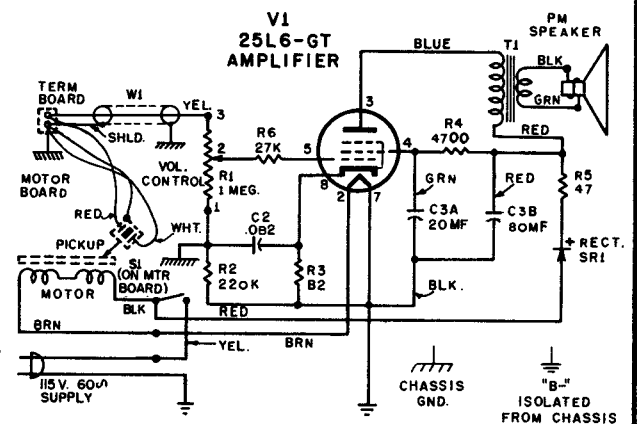

Chassis Assembly (Top View)



RCA VICTOR

7-EY-2JJ and 7-EY-2HH

Chassis No. RS-155A
Record Changer RP-190D-2

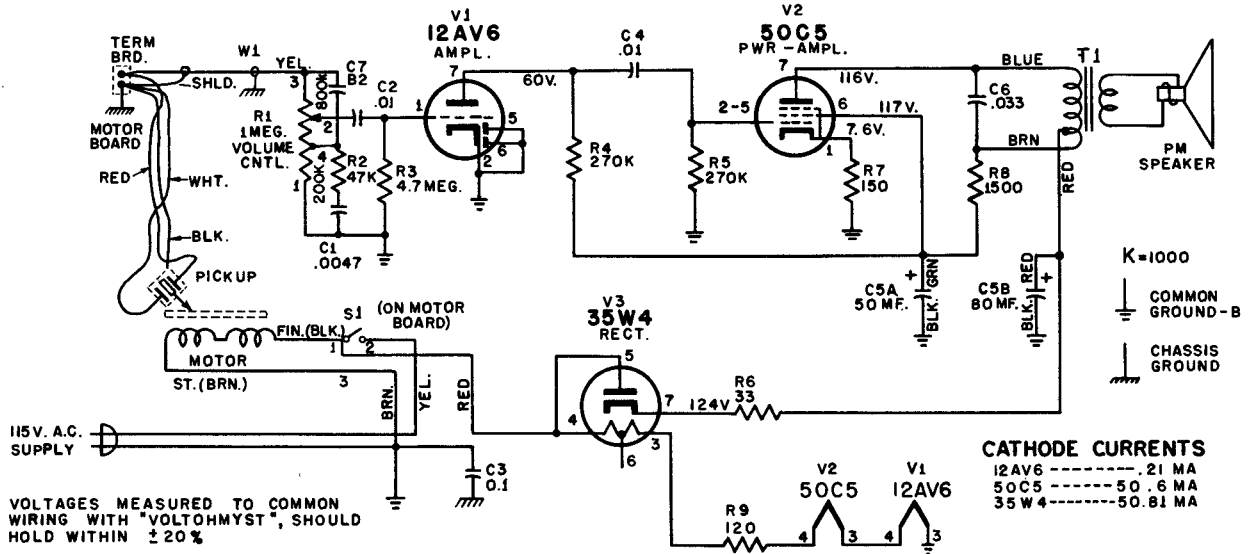

RCA VICTOR

Portable Automatic Record Player

MODEL 6-ES-5

Chassis No. RS-157
Record Changer RP-198-5A

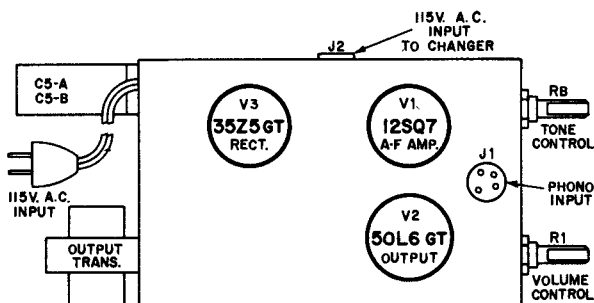

CRITICAL LEAD DRESS

1. Dress all leads away from R₅ and R₇.
2. Dress R₃ down next to chassis.
3. Dress all A.C. leads away from audio input circuit.
4. Dress power cord and other leads away from moving parts of record changer.

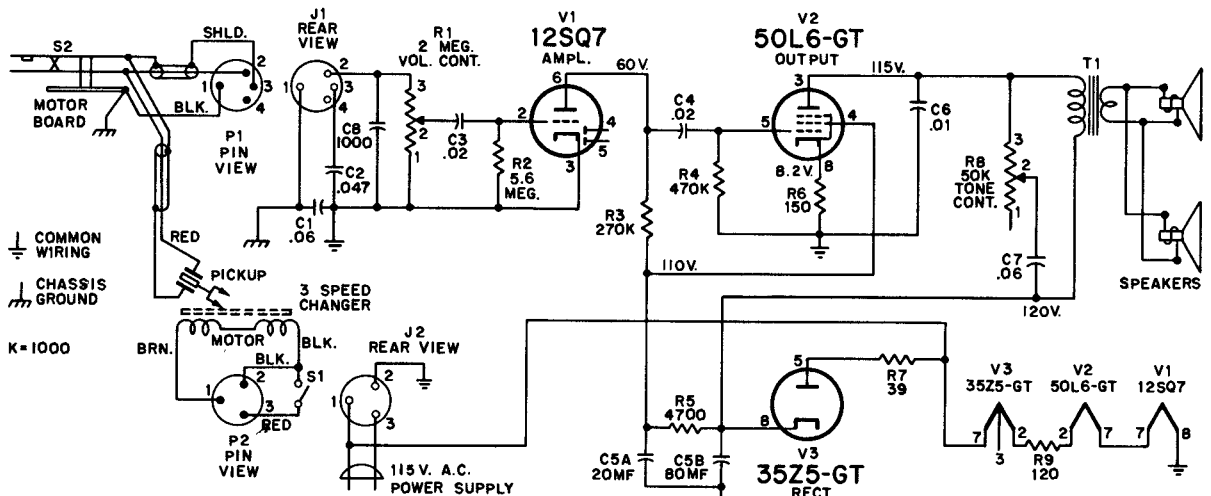

RCA VICTOR

MODELS 6-B-4A, 6-B-4B, 6-B-5

Chassis No. RC-1098B

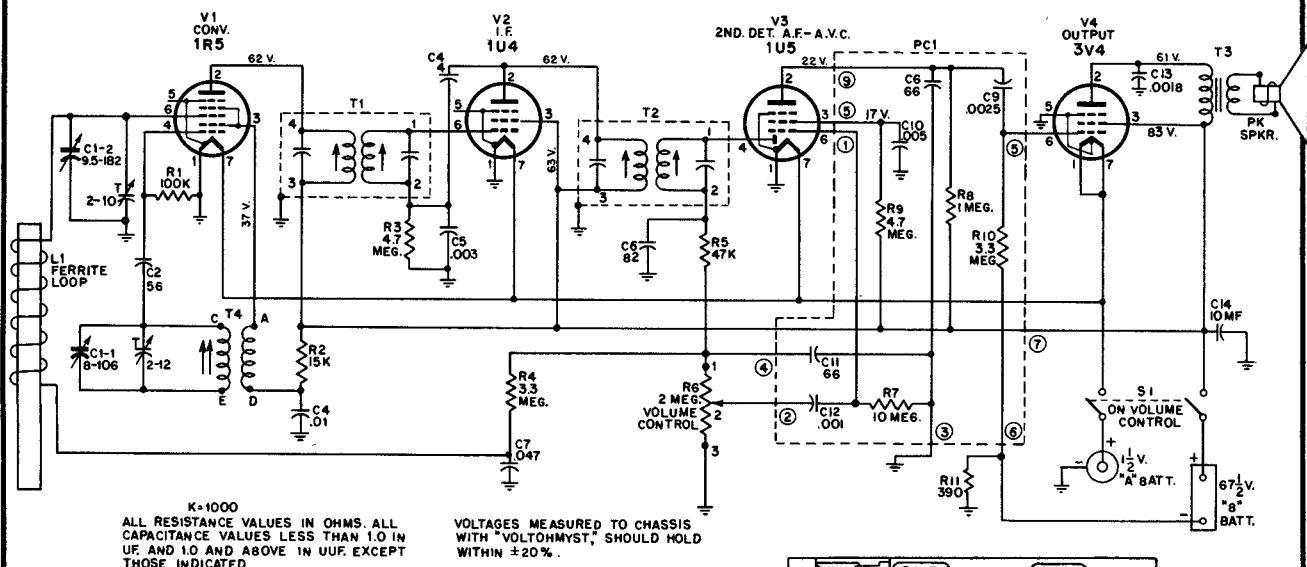

Alignment Procedure

Output Meter.—Connect meter from No. 2 terminal of V4 (plate of 3V4) to ground. Turn volume control to maximum position.

Test-Oscillator.—For all alignment operations, connect the low side of the test-oscillator to the receiver chassis, and keep the oscillator output as low as possible to avoid a-v-c action.

Note.—The Ferrite rod antenna coil is pre-adjusted and cemented to rod. Further adjustment is unnecessary. However, when replacing ant. assembly make certain that the coil end of the rod extends two inches beyond the tube shelf.

Steps	Connect the high side of test osc. to—	Tune test-osc. to—	Turn radio dial to—	Adjust the following for max. peak output—
1	Connection lug of C1-2 located on rear of gang in series with .01 ml.	455 kc	Quiet point near 1600 kc	Top and bottom cores 2nd I-F trans.†
2				Top and bottom cores 1st I-F trans.†
3	*Antenna coupling loop (Chassis in case)	1620 kc	Gang fully open	C1-1† (osc.)
4		1400 kc	1400 kc signal	C1-2† (ant.)
5		600 kc	600 kc signal Rock gang	T4 (osc.)
6	Repeat steps 3, 4 and 5			

*Steps 3, 4 and 5 require a coupling loop from the signal generator to feed a signal into the receiver ant. coil. This loop should be loosely coupled to the receiver antenna coil so as not to disturb the receiver ant. coil inductance.

†Both cores are adjustable from top of transformer. Use double-ended hexagon alignment tool.

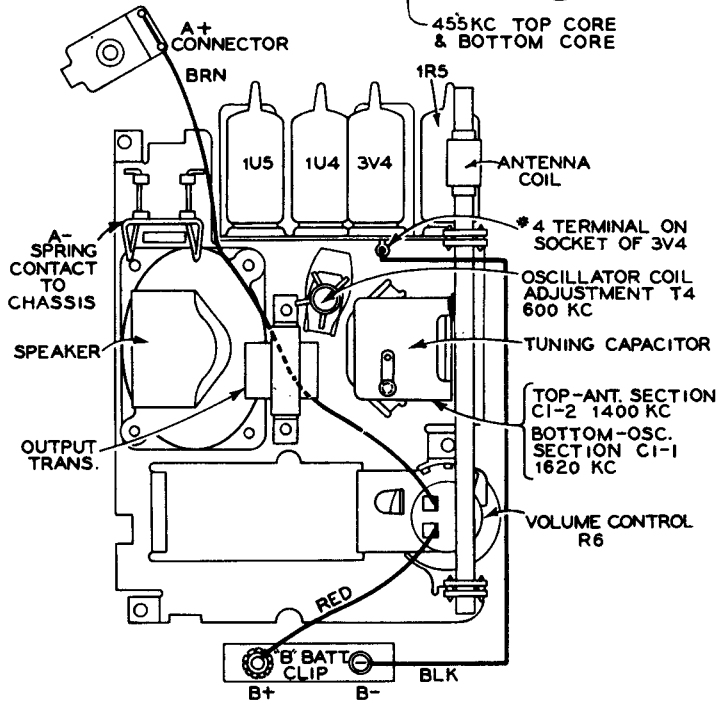
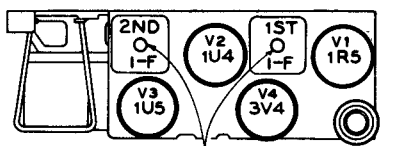

- I. To Remove Back Cover
 - a. Insert edge of coin into slot in back cover (midway between handle supports) and twist until the back cover disengages from the main case.
 - b. Pull the back cover back and up, thereby unhooking the retaining lugs in the bottom of the main case.
- II. To Replace Batteries
 - a. Remove back cover.
 - b. Remove either or both "A" and "B" batteries as may be necessary. The "B" battery snap fasteners can best be removed by inserting a screwdriver under the snap fastener strip and prying upward.

VOLUME R-16, MOST-OFTEN-NEEDED 1956 RADIO SERVICING INFO

RCA Victor Models 6-BX-8A, 6-BX-8B, Chassis No. RC-1126A

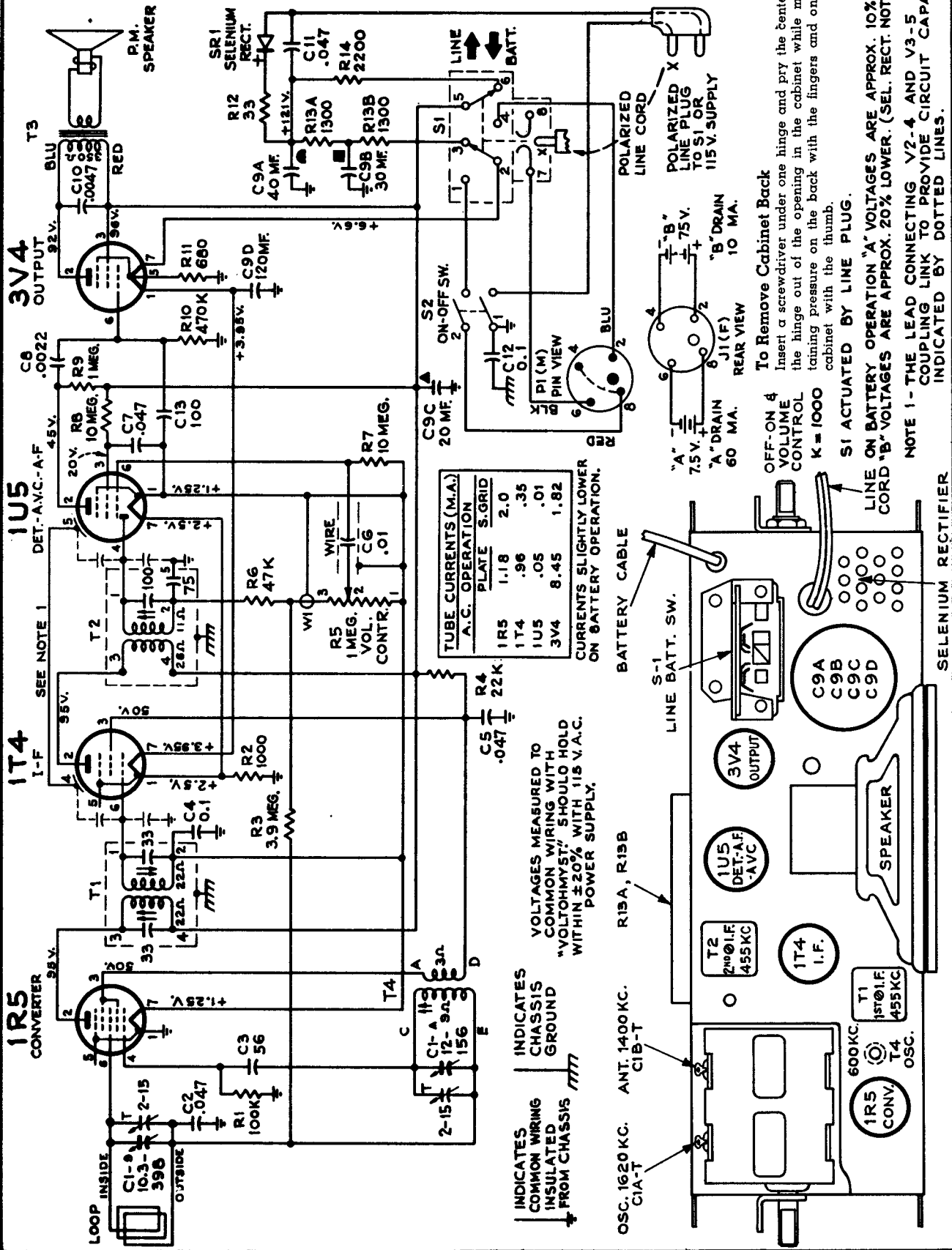

To Remove Cabinet Back
 Insert a screwdriver under one hinge and pry the center of the hinge out of the opening in the cabinet while maintaining pressure on the back with the fingers and on the cabinet with the thumb.

OFF-ON & VOLUME CONTROL
 K = 1000
 S1 ACTUATED BY LINE PLUG.

LINE ON BATTERY OPERATION "A" VOLTAGES ARE APPROX. 10% HIGHER
CORD "B" VOLTAGES ARE APPROX. 20% LOWER. (SEL. RECT. NOT USED)

NOTE 1 - THE LEAD CONNECTING V2-4 AND V3-5 IS A COUPLING LINK TO PROVIDE CIRCUIT CAPACITY INDICATED BY DOTTED LINES.



RCA VICTOR

Model 6-X-7 Series

Chassis No. RC-1128B

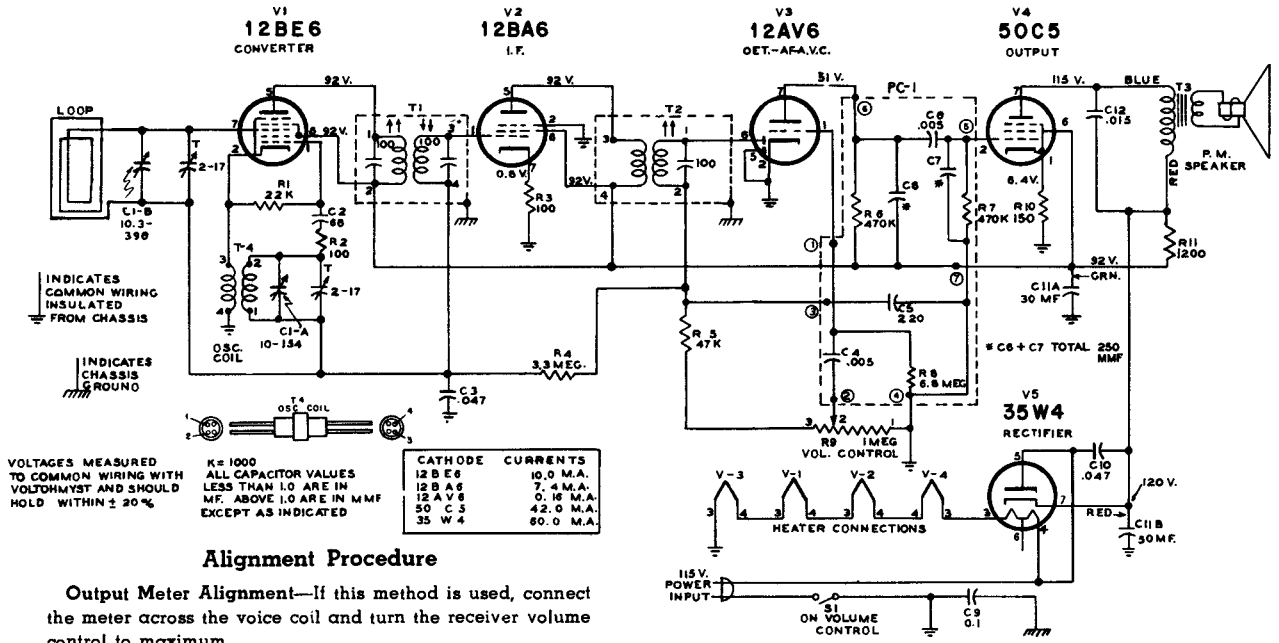

Alignment Procedure

Output Meter Alignment—If this method is used, connect the meter across the voice coil and turn the receiver volume control to maximum.

Test-Oscillator—For all alignment operations, connect the low side of the test-oscillator to the receiver chassis, and keep the oscillator output as low as possible to avoid a-v-c action.

On a.c. operation an isolation transformer (115 v./115 v.) may be necessary for the receiver if the test oscillator is also a.c. operated.

Critical Lead Dress

1. Dress all circuit wiring against chassis.
2. Dress C10 such that possibility of lead shorts to chassis are minimized.
3. Dress PC unit away from I.F. circuits and chassis.
4. Dress C12 away from end of chassis to prevent shorts to side of bottom cover.
5. Dress R12 away from chassis and C10.

Steps	Connect the high side of test-oscillator to—	Tune test-osc. to—	Turn radio dial to—	Adjust the following for max. output
1	12BA6 I-F grid through .01 mfd. capacitor	455 kc	Quiet-point 1600 kc end of dial	T2 (top) 2nd I-F trans.
2	Stator of C1-B through .01 mfd.			T1 (top and bottom) 1st I-F trans.
3	Short wire placed near loop to radiate signal	1620 kc	Min. cap.	osc. trimmer C1A-T
4		1400 kc	1400 kc signal	ant. trimmer C1B-T
5	Repeat steps 3 and 4.			

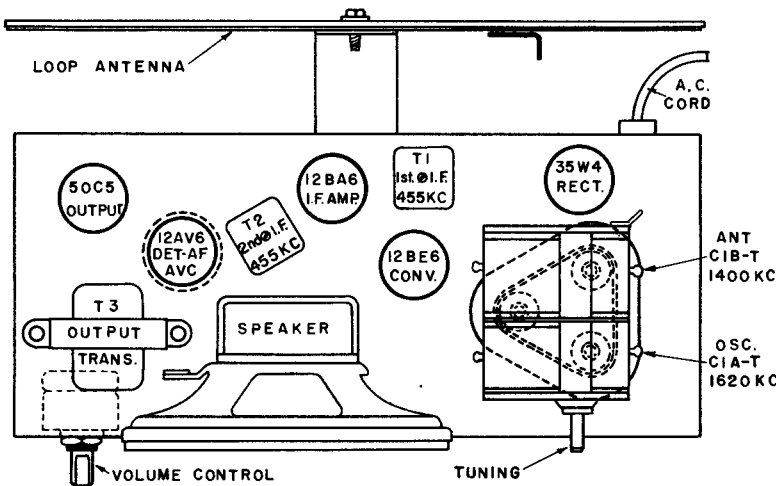

Tube and Trimmer Locations

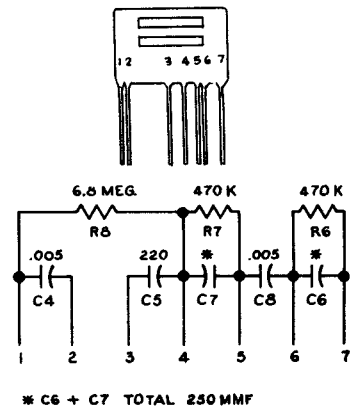

PC-1 Terminal Connections

RCA VICTOR

MODEL 6-XD-5

Chassis No. RC-1146A

LEAD DRESS

1. Dress all heater leads down to chassis.
2. Dress R12 (33 ohm resistor) away from all leads.
3. Dress C11 in such manner as to prevent shorts to chassis.
4. Dress audio leads to volume control away from a.c. leads.

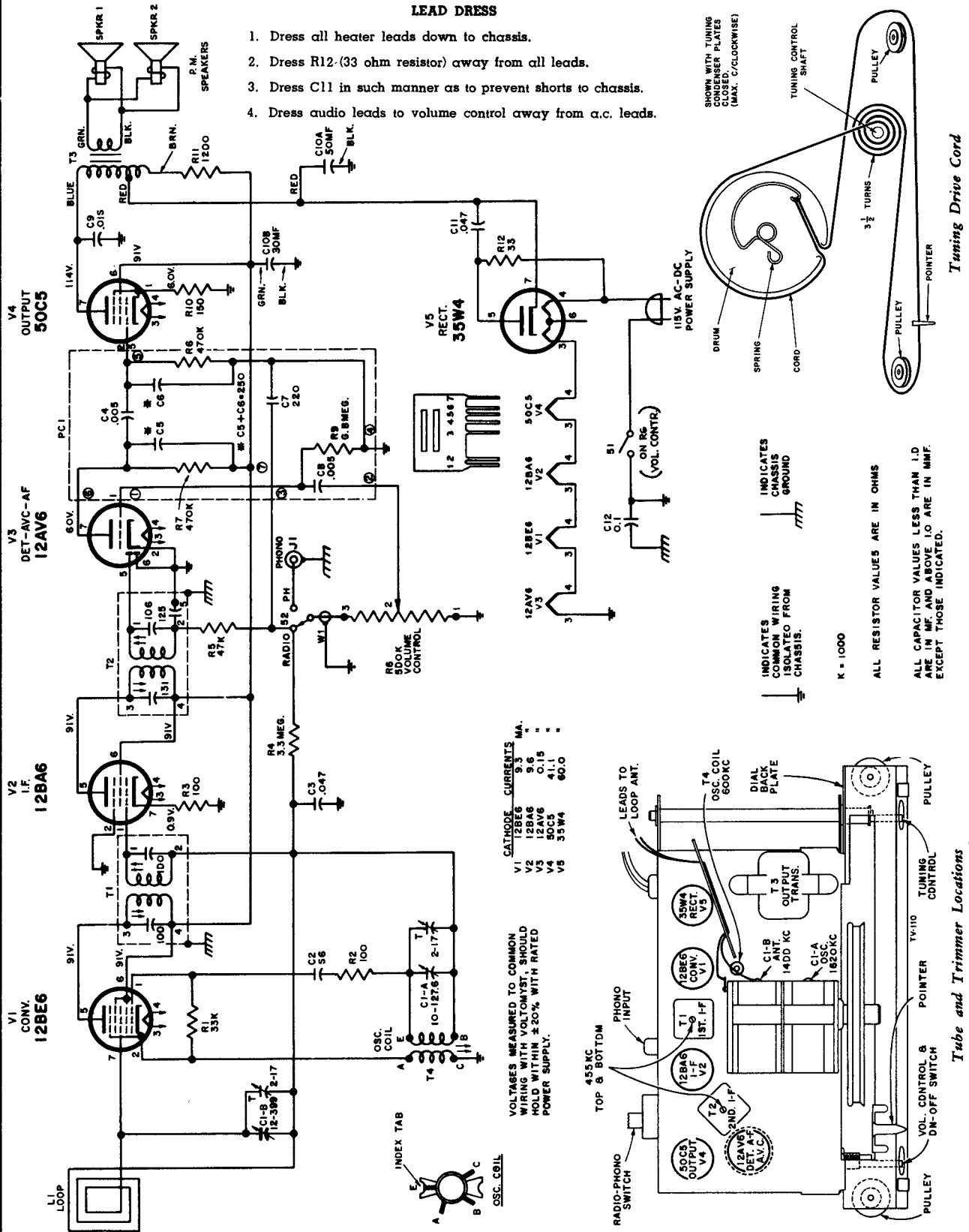

SHOWN WITH TUNING
KERNER PLATES
CLOSED.
(MAX. C/CLOCKWISE)

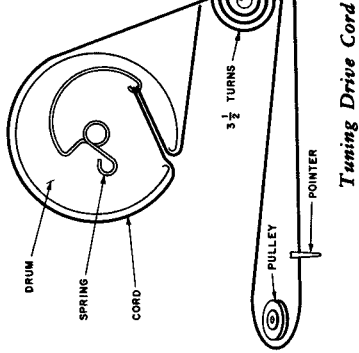

Tuning Drive Cord

INDICATES
COMMON WIRING
ISOLATED FROM
CHASSIS.



INDICATES
CHASSIS
GROUND



K = 1000

ALL RESISTOR VALUES ARE IN OHMS

ALL CAPACITOR VALUES LESS THAN 1.0
ARE IN MF AND ABOVE 1.0 ARE IN MMF.
EXCEPT THOSE INDICATED.

CATHODE CURRENTS MA.

V1	12BE6	9.3
V2	12BA6	9.6
V3	12AV6	1.9
V4	50C5	4.1
V5	35W4	60.0

VOLTAGES MEASURED TO COMMON
WIRING WITH VOLTMETER, SHOULD
HOLD WITHIN ±20% WITH RATED
POWER SUPPLY.

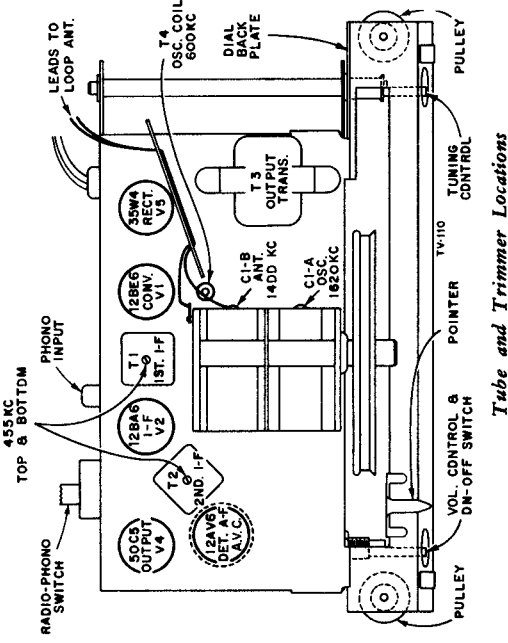

Tube and Trimmer Locations



RCA VICTOR

MODELS 6-XY-5A, 6-XY-5B

Chassis No. RC-1152

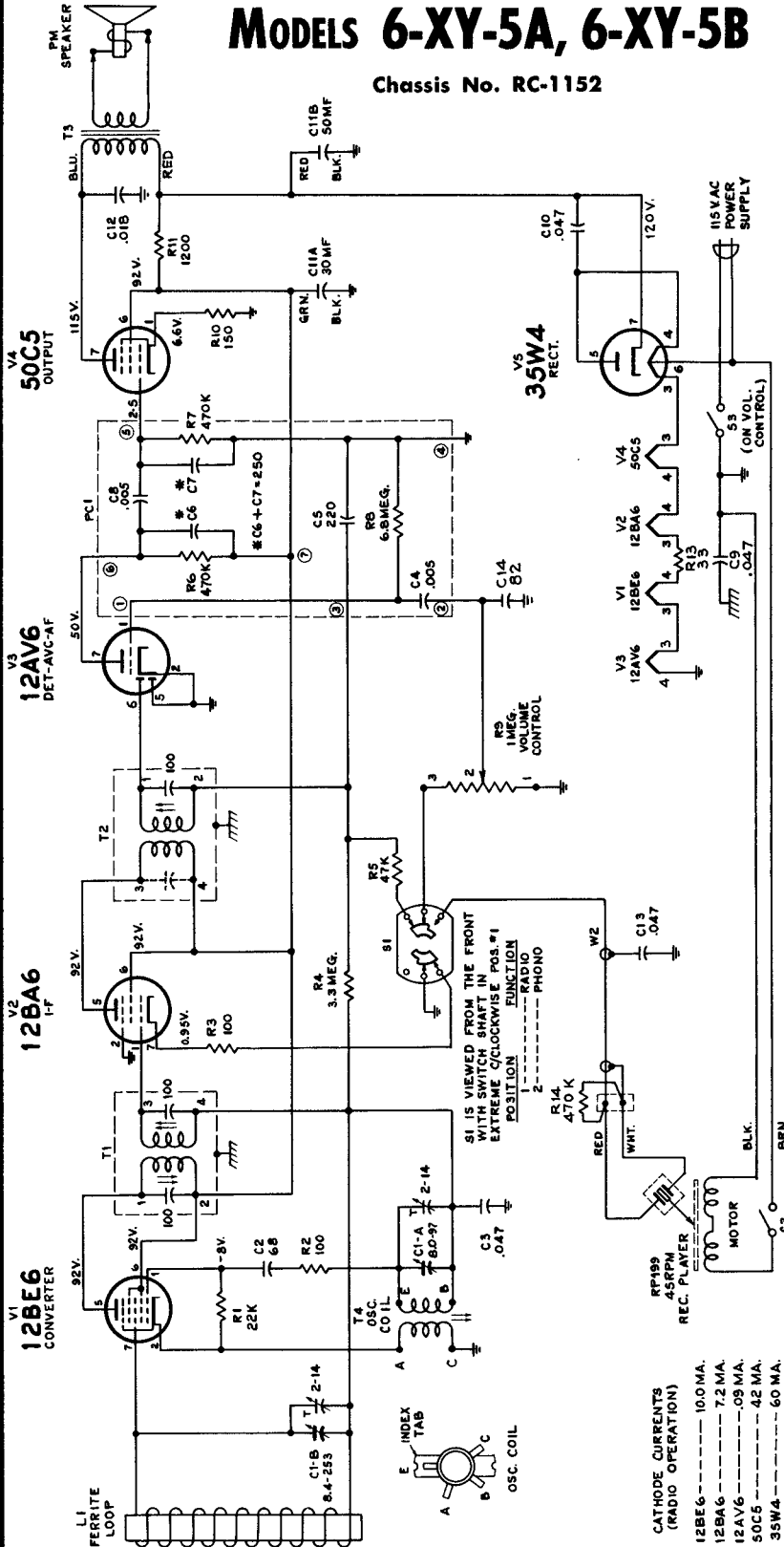

RESISTANCE VALUES IN OHMS. K=1000
 ALL CAPACITANCE VALUES LESS THAN 1.0 IN MF AND 1.0 AND ABOVE ARE IN MMF UNLESS OTHERWISE NOTED.
 VOLTAGES MEASURED WITH FUNCTION SWITCH IN "RADIO" POSITION.

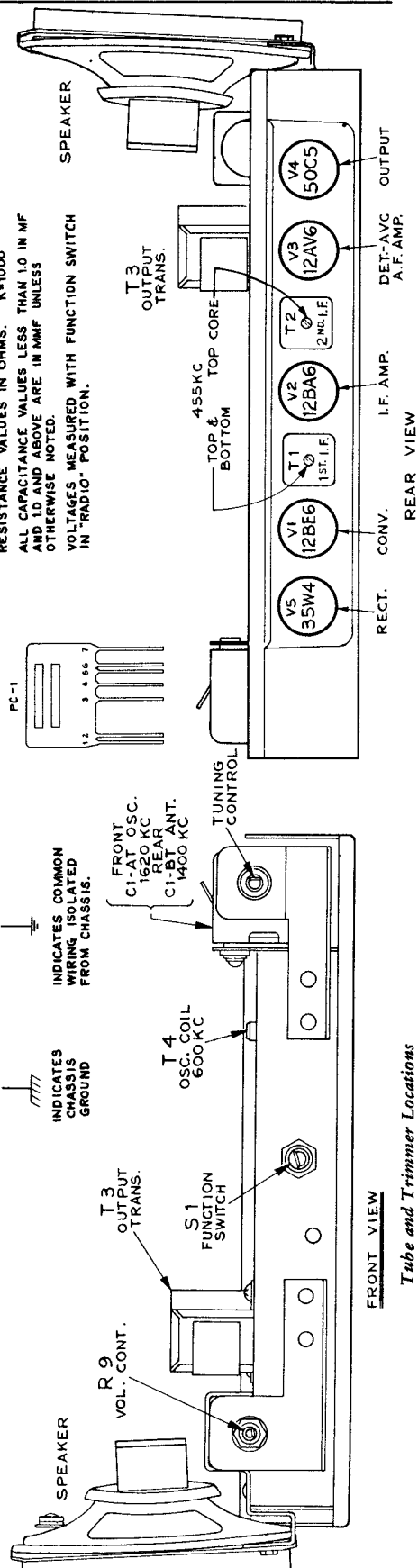

Tube and Trimmer Locations



RCA VICTOR

MODELS 6-BY-4A, 6-BY-4B

Chassis Nos. RC-1153, RC-1153A

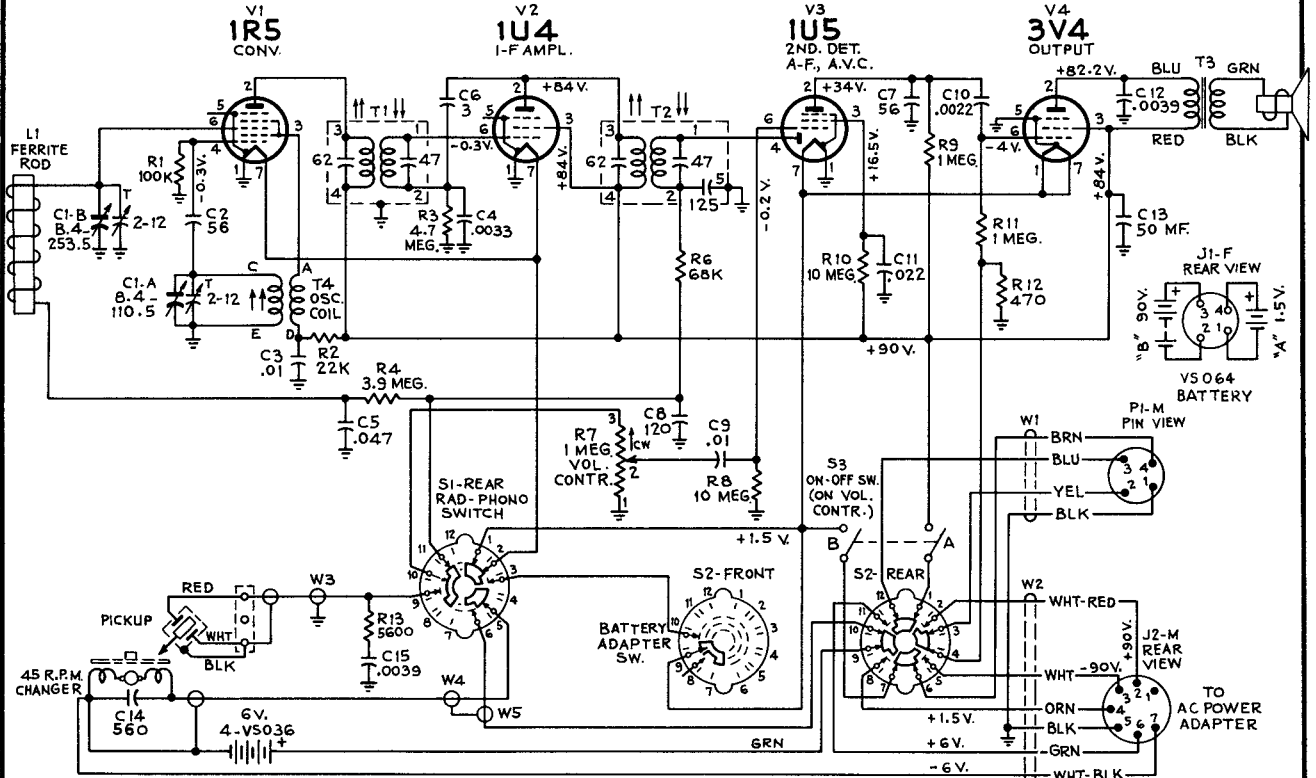

CHASSIS REMOVAL

For access to tubes and batteries, it is necessary only to remove the four slotted screws holding the bottom cover to the case.

To remove the chassis, it is necessary to:

1. Pull off four control knobs.
2. Remove bottom cover.
3. Remove batteries.
4. Disconnect shielded cable from terminal board near pickup arm mounting.
5. Disconnect wires from phono motor.
6. Unfasten adapter socket (J2) and "Battery-Adapter" switch (S2) from cabinet.
7. Remove four chassis mounting screws.

STYLUS REPLACEMENT

For access to the ceramic pickup, it is only necessary to lift the end of the pickup arm and move it to the right so that it projects over the edge of the cabinet.

To remove stylus, grip with tweezers at back end and pull away from the pickup. The shank of the stylus holder is imbedded in a rubber block which is set in a "U" shaped spring clip. This spring clip holds the stylus assembly to a plastic support. The shank of the stylus rests in a metal saddle.

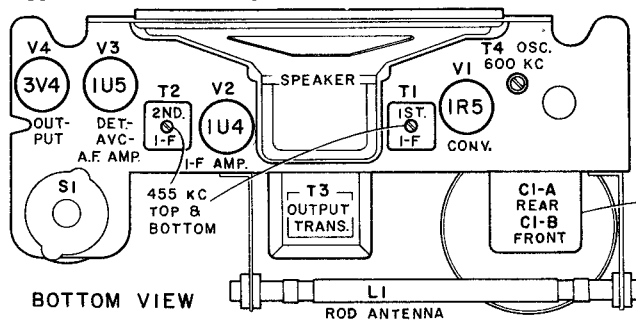

PHONO MOTOR BATTERY

The phono motor battery must be placed in its retaining clips with the removable cap end to the left. If the battery is reversed, the motor will turn in the wrong direction.

The location of the phono motor battery affects the antenna inductance. When making adjustment of C1-B antenna trimmer, this battery must be placed parallel to and 3/4-inch away from the antenna rod.

RESISTANCE VALUES IN OHMS. K=1000
CAPACITANCE VALUES LESS THAN 1, IN MF.
1 AND ABOVE IN MMF. UNLESS OTHERWISE NOTED.

SOCKET VOLTAGES MEASURED TO CHASSIS WITH "VOLTOHMYST" SHOULD HOLD WITHIN ±20% WITH NEW BATTERIES.

S1 AND S2 FRONT AND REAR SECTIONS VIEWED FROM FRONT AND SHOWN IN MAX. COUNTER. CLOCKWISE POS. NO. 1

- S1 POS. 1 - RADIO.
2 - PHONO.
S2 POS. 1 - BATTERY.
2 - A.C. POWER ADAPTER

NOTES

In "PHONO" position, the filaments of the 1R5 and 1U4 tubes are not energized when the BATTERY-ADAPTER switch (S2) is in "BATT" position.

Power to the phono motor is not controlled by the "ON-OFF" switch on volume control; it is controlled only by the "RADIO-PHONO" switch.

Tuning Drive Cord

GANG IN MAXIMUM CLOCKWISE POSITION

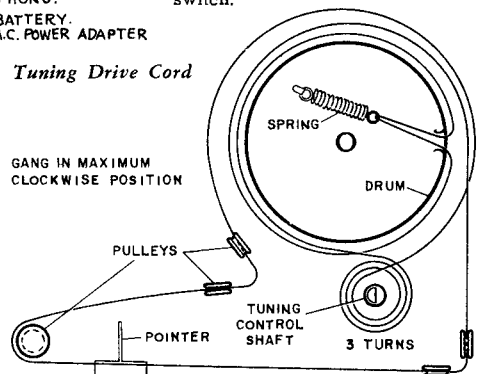

RCA VICTOR

MODEL 7-BT-10K

Chassis No. RC-1156

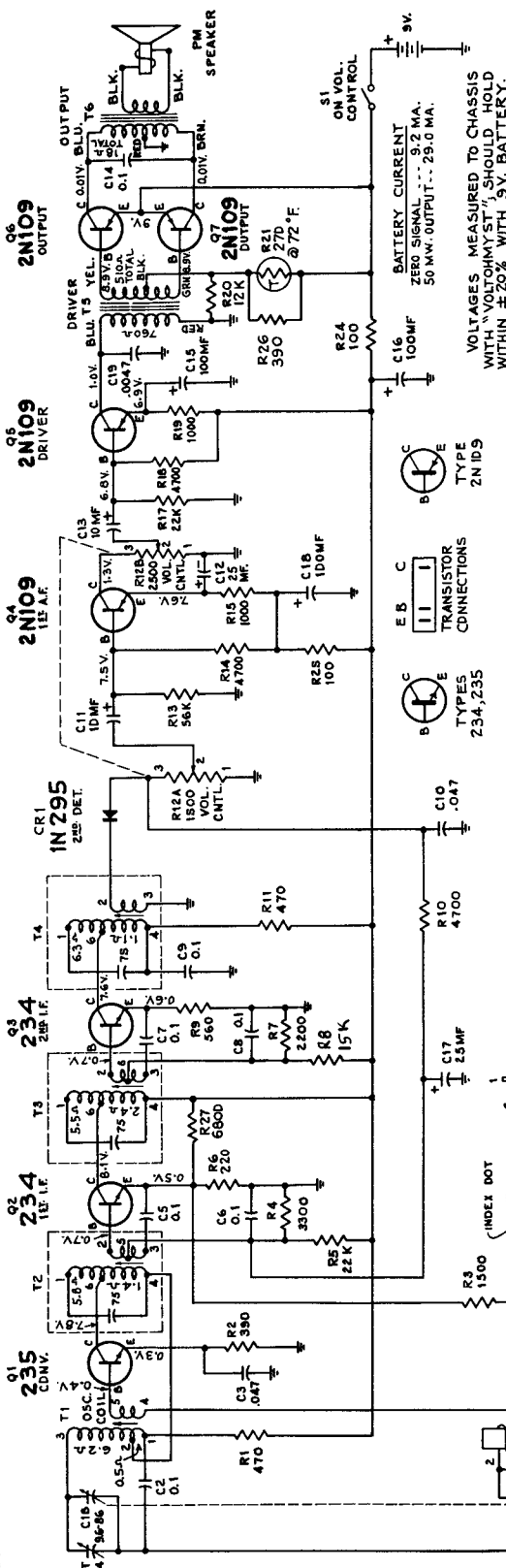

VOLTAGES MEASURED TO CHASSIS WITH VOLTOHM METER SHOULD HOLD WITHIN $\pm 20\%$ WITH 5V BATTERY.

ALL RESISTANCE VALUES IN OHMS, K=1000

ALL CAPACITANCE VALUES LESS THAN 1.0 IN MF AND 1.0 μ ABOVE IN MMF, EXCEPT THOSE INDICATED.

TUNING RANGE 540-1600 kc
 INTERMEDIATE FREQUENCY 455 kc

TRANSISTOR COMPLEMENT

1. Type 235 Converter
2. Type 234 1st I-F Amplifier
3. Type 234 2nd I-F Amplifier
4. Type 2N109 1st A-F Amplifier
5. Type 2N109 Audio Driver
6. Type 2N109 Push-pull Output
7. Type 2N109 Push-pull Output

A type 1N295 crystal diode is used as 2nd detector.

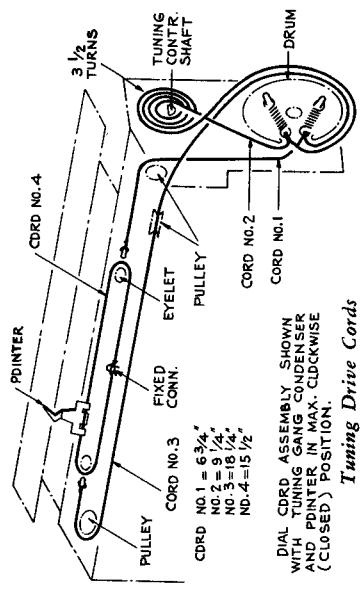

Tuning Drive Cords

- Extremes care should be used to avoid accidental shorting of transistor elements to circuit ground. This is especially true of the output transistors; if the junction of R20-R21 should be accidentally grounded for a few seconds, the output transistors would be permanently damaged.
- The polarity of the AGC voltage measured at the volume control end of CR1 will be slightly positive with no signal input. The negative voltage developed with signal input will not harm electrolytic capacitor C17.
- Application of a signal from a signal generator to the input (B) of Q1 will stop oscillator action (R-F signal can not be injected at this point although 455 kc I-F signal can be injected).
- Oscillator performance can not be judged by measurement of a d-c voltage developed across a resistor. Measurement of oscillator signal strength with an a-c voltmeter at the input of Q1 (Base contact) will give an indication of oscillator performance.
- Voltage measurements should be made only with a sensitive voltmeter, such as an RCA VoltOhmyst.
- Interchanging transistors in the I-F stages may necessitate realignment.
- A transistor should always be removed from its socket before using a soldering iron on socket terminals.
- It is possible to damage a transistor when testing circuit continuity. Since a transistor needs only low voltage applied to its terminals for conduction, testing continuity of a circuit which includes a transistor can result in misleading continuity indications. To avoid transistor damage and misleading continuity indications, remove the transistor from its socket before making continuity tests of its circuit.

SERVICE HINTS

- The first thing to check when the receiver is inoperative, is the battery. With the receiver turned on, a new battery should test 9 volts although the receiver can be expected to operate with a battery which tests 6 volts or more.
- To check for a circuit defect which would cause excessive battery drain, an overall current measurement and supplementary voltage measurements should be made. For reasons explained below, continuity measurements can be misleading.
- Signal tracing by injection of a signal from a signal generator is done on transistor radios in exactly the same manner as has been done for many years with the conventional vacuum tube radios. The signal generator should be connected (as in past practice) in series with a capacitor to avoid shorting out bias voltages. With the transistors used in this receiver, the BASE is the signal input terminal (corresponding to signal grid of tubes), the COLLECTOR is the signal output terminal (corresponding to plate of tubes), and the EMITTER is the common terminal (corresponding to cathode of tubes).
- The "Class B" output used in this receiver is a system which, although not new, has been seldom used in home radios for the past several years. It should be noted that in "Class B" output the battery current increases greatly with increased signal input to the "Class B" tubes.



RCA VICTOR

MODEL 6-X-5 SERIES

Chassis No. RC-1157

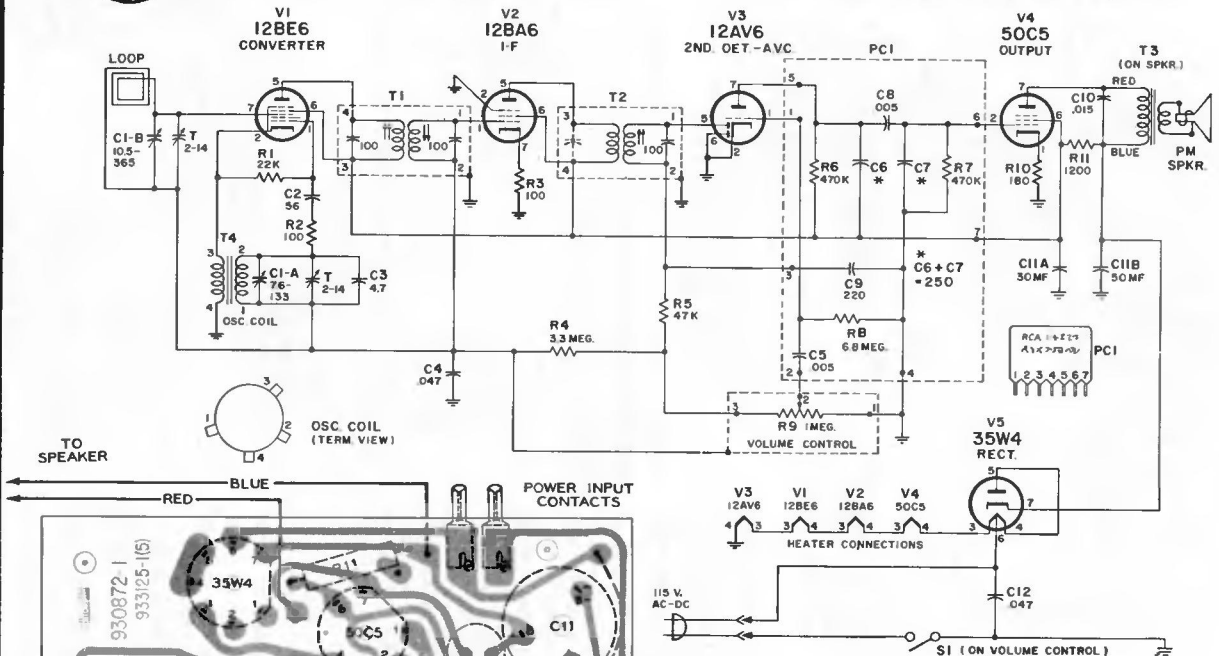

K=1000. ALL RESISTANCE VALUES IN OHMS.
ALL CAPACITANCE LESS THAN 1.0 IN MF &
1.0 & ABOVE IN MUF EXCEPT THOSE INDICATED.
⊥ INDICATES "COMMON NEGATIVE WIRING"

The assembly represented above is viewed from the wiring side of the board.
The printed wiring, on the near side of the board, is presented in "phantom" view superimposed on the component layout of the reverse side.

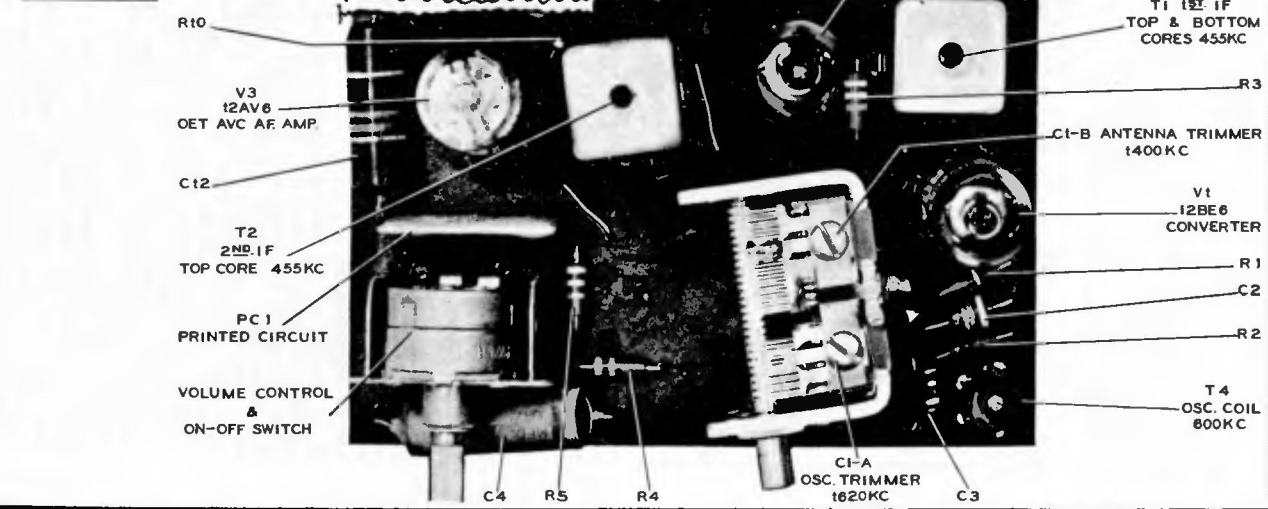
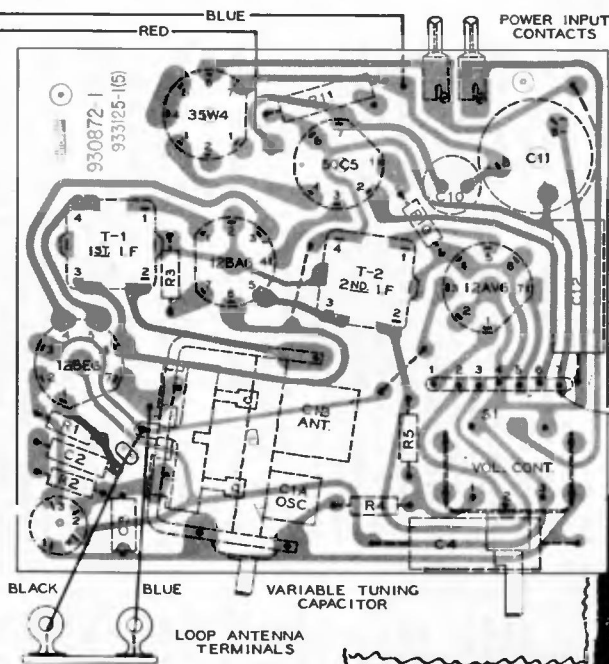

RCA VICTOR

MODEL 6-C-5 SERIES, 7-C-6 SERIES

Chassis No. RC-1157A

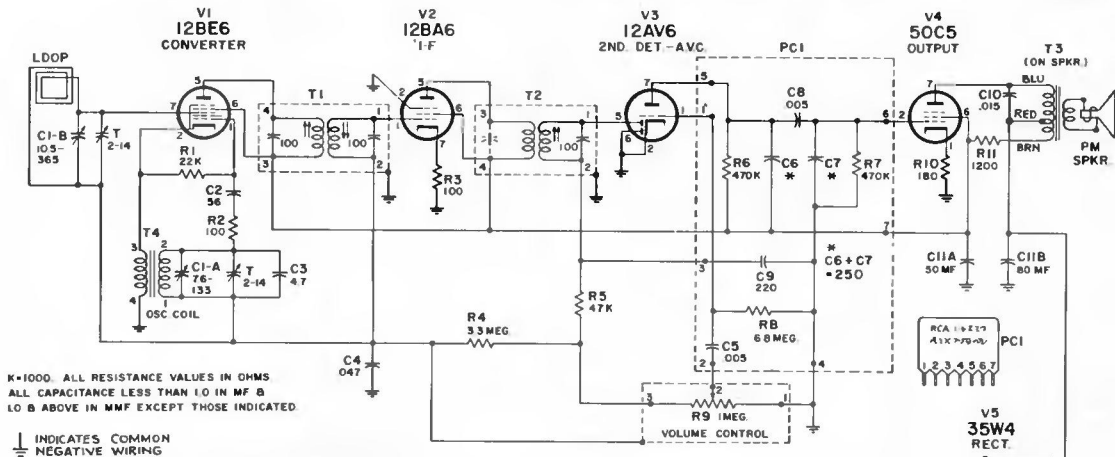

Step	Connect the high side of test-oscillator to—	Tune test-osc. to—	Turn radio dial to—	Adjust the following for max. output
1	12BA6 I-F grid through .01 mfd. capacitor	455 kc	Quiet-point 1,600 kc end of dial	T2 (top) 2nd I-F trans.
2	Stator of C1-B through .01 mfd.			T1 (top and bottom) 1st I-F trans.
3		1,620 kc	Max. clockwise	osc. trimmer C1-A
4	Short wire placed near loop to radiate signal	1,400 kc	1,400 kc signal	ant. trimmer C1-B
5		600 kc	600 kc signal	osc. coil T-4 (rock gang)
6	Repeat steps 3, 4, and 5			

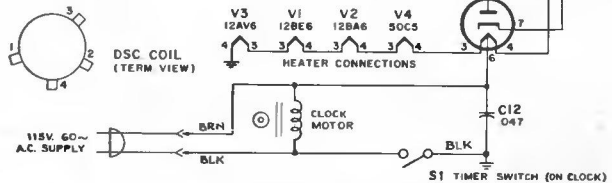

TO REMOVE BACK COVER

1. Slip out of upper groove while pressing upward on top edge of cabinet.
2. Tilt outward to free interlock contacts, then lift from bottom grooves.

REMOVAL OF CHASSIS

1. Pull off volume control and tuning knobs.
2. Remove back cover.
3. Remove one screw (near volume control) holding chassis to cabinet.

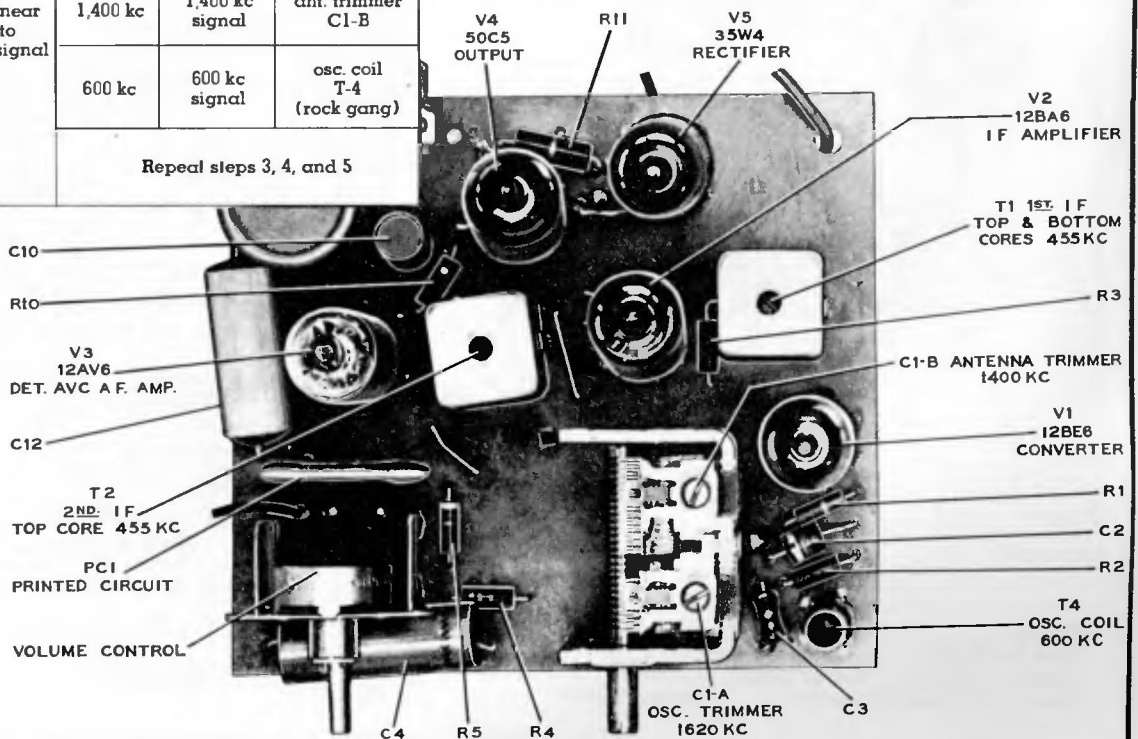



RCA VICTOR

MODEL 7-BT-9J

Chassis No. RC-1159

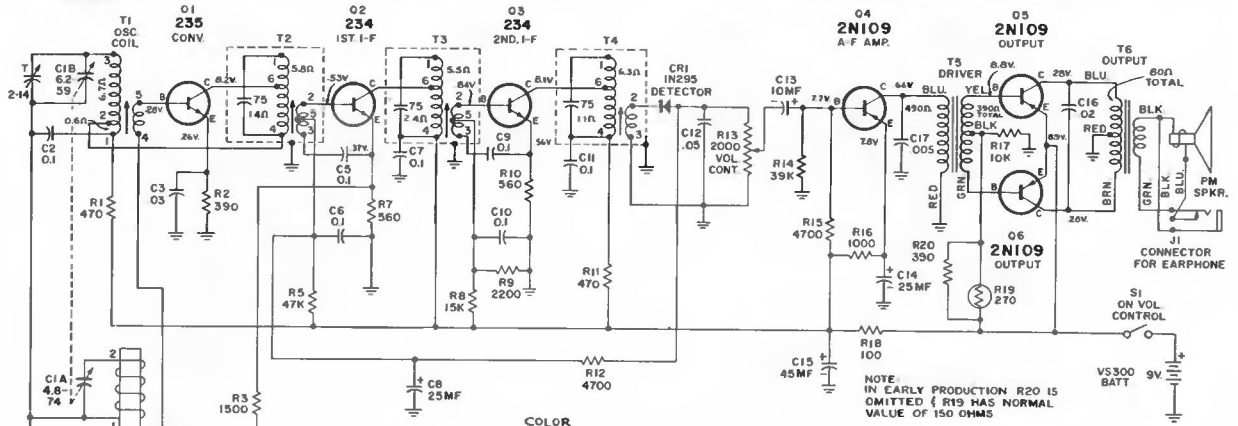

NOTE: IN EARLY PRODUCTION R20 IS OMITTED & R19 HAS NORMAL VALUE OF 150 OHMS.

VOLTAGES MEASURED WITH "VOLTOHMYST" SHOULD HOLD WITHIN 220% WITH NEW BATTERY K=1000. ALL RESISTANCE VALUES IN OHMS. ALL CAPACITANCE VALUES LESS THAN 1.0 IN MF AND 1.0 IN MMF EXCEPT THOSE INDICATED.

TUNING RANGE 540-1,600 kc
 INTERMEDIATE FREQUENCY 455 kc

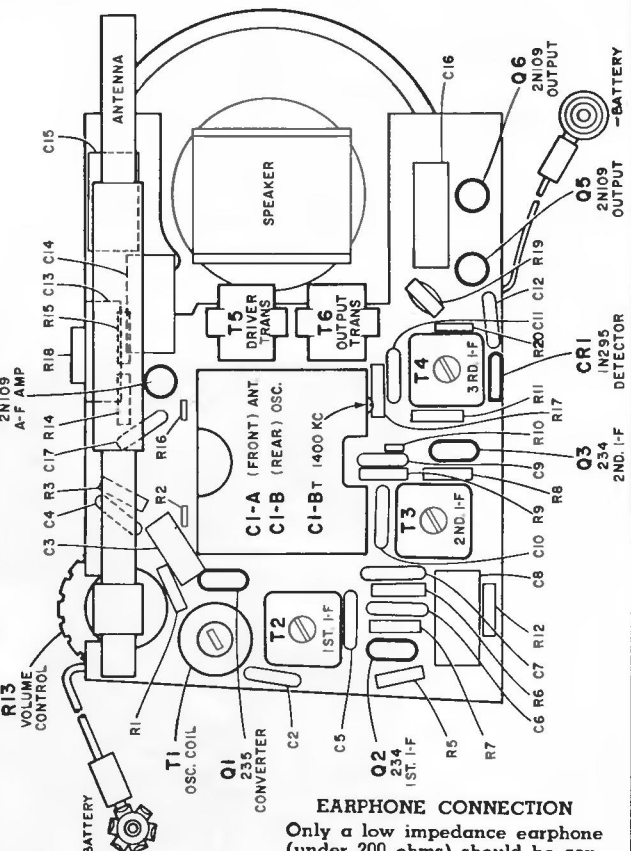
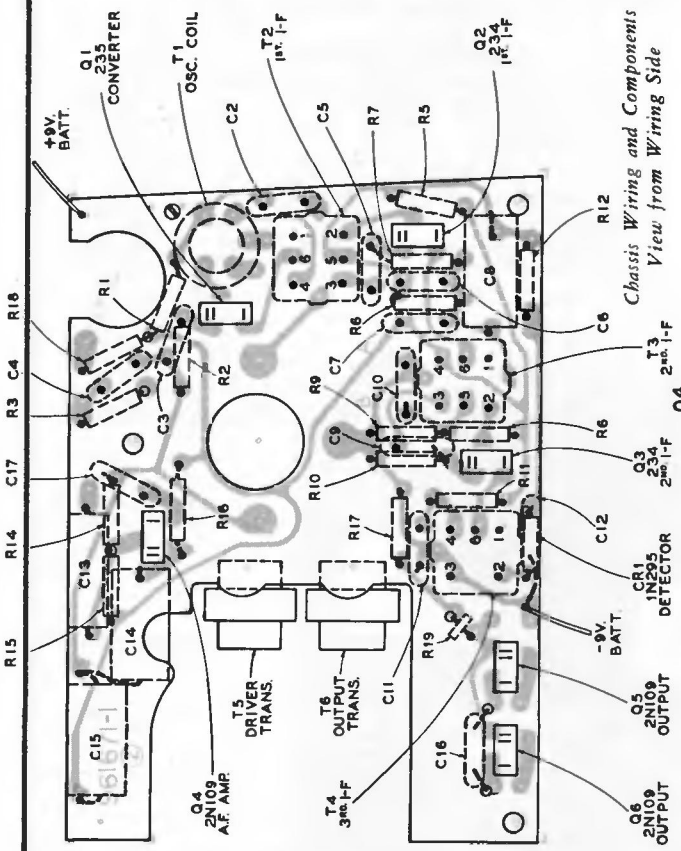
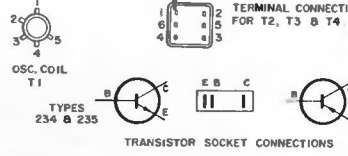

BATTERY:
 Type No. VS-300 9 volts
 Current consumption (with no signal) Approx. 6 ma
 Useful life (intermittent service) Approx. 75 hours

The assembly represented above is viewed from the wiring side of the board.
 The printed wiring, on the near side of the board, is presented in "phantom" view superimposed on the component layout of the reverse side.

MODEL 6-HFT-1 Tape Recorder TR-1A

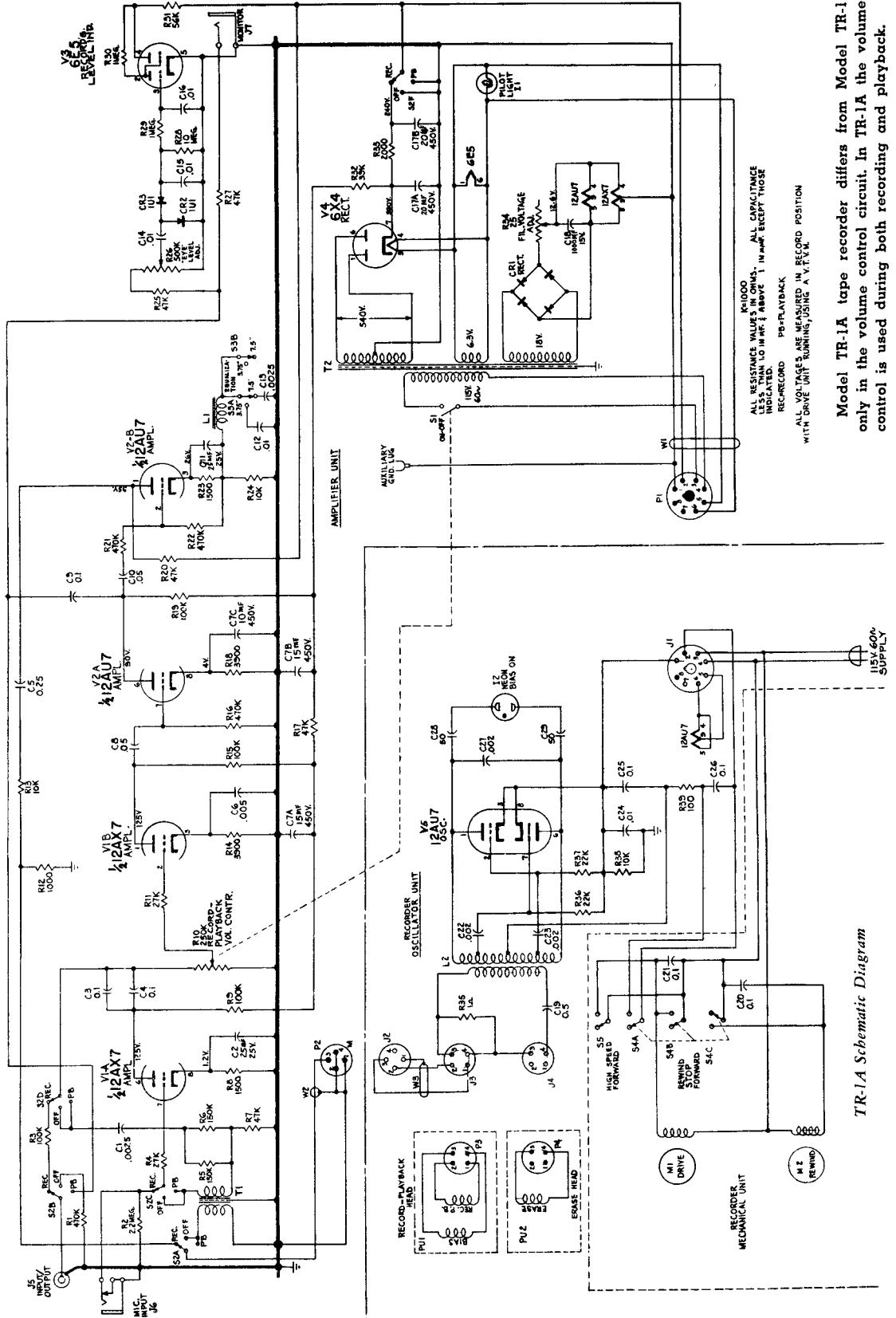

115V 60Hz SUPPLY
 ALL RESISTANCE VALUES IN OHMS, ALL CAPACITANCE VALUES IN MICRO-FARADS UNLESS INDICATED OTHERWISE.
 ALL VOLTAGES ARE MEASURED IN RECORD POSITION WITH DRIVE UNIT RUNNING, USING A V.T.V.M.
 RECORDED PB-PLAYBACK

Model TR-1A tape recorder differs from Model TR-1 only in the volume control circuit. In TR-1A the volume control is used during both recording and playback.

TR-1A Schematic Diagram

RCA VICTOR

Model RP-199 "Slide-O-Matic"

DESCRIPTION

The RP-199 "Slide-O-Matic" mechanism is a 45 rpm single play record player which is operated by simply sliding a record through a slot in the cabinet and then raising the play control.

Raising the play control starts the turntable rotating and automatically permits the pickup stylus to set on the record. Since the pickup arm is not accessible it is almost impossible to get out of adjustment.

The mechanism will stop automatically after the selection has been played and the record can easily be withdrawn. Should a person wish to stop the mechanism while in operation, simply push in on play control; withdraw the record after play control drops down.

The mechanism is made up of a lower and upper subassembly. The lower subassembly is provided with a power switch mounting bracket, pickup arm mounting bracket, pickup arm lever and a hinged support for the upper subassembly.

The upper subassembly provides the necessary facilities to mount the drive motor, turntable, idler wheel, trip lever, reject lever, bumper, record stop and guides.

The turntable is driven by a conventional idler wheel assembly which gives additional speed reduction by coupling together two rubber drive wheels of different diameters.

ADJUSTMENT

Tripping Adjustment

The mechanism is provided with a tripping adjustment screw that should be adjusted so the mechanism trips when the stylus is approximately 1/4" from the edge of the record center hole.

Pickup Inward Travel Limit

The inward travel of the pickup stylus should be limited to 1-3/16" from the edge of the center hole, so the stylus cannot enter the record label area. This limit is governed by bending of a metal tab.

Landing Adjustment

The contact between the pickup arm lever and a metal tab extending upward from the lower subassembly, limits the outward travel of the pickup arm. This outermost position coincides with the landing position of the pickup. Bend the tab so the pickup stylus lands approximately 2 3/8" from the record center hole (Halfway between the outer edge and the recorded section of a standard record).

Pickup Height Adjustment

The pickup height should be adjusted so the pickup raises approximately 1/8" when raising the play control to move the record into playing position. Adjust to desired height by bending of a metal tab.

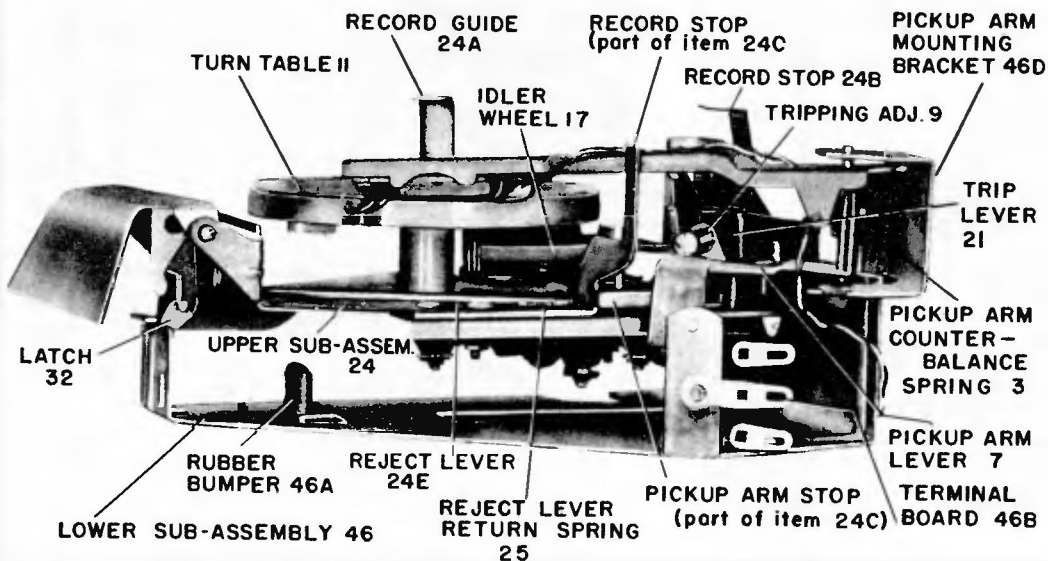
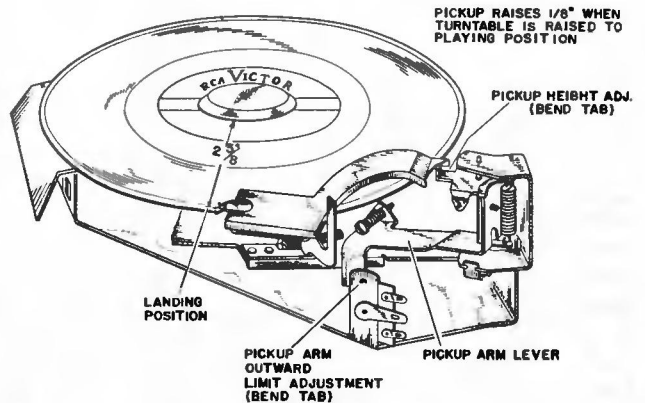
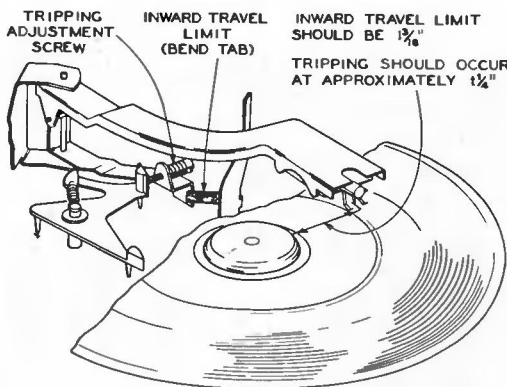

Continued on the next for pages.

RCA Victor Model RP-199 Record Player (Continued)

CYCLE OF OPERATION

Inserting Record

Slide a record over the turntable (thru slot in cabinet) until the record touches the stop, at which time the record will set on the turntable correctly.

Starting Mechanism

Raise the play control (38) that is mechanically connected to the upper subassembly; the upper subassembly (which is pivoted at the rear of the lower subassembly) raises with it. This action causes a small arm extending from the bottom of the upper subassembly to actuate the power switch and start the turntable rotating.

As the play control is raised up, the record on the rotating turntable gently meets the pickup stylus in the starting groove and the record starts playing.

When the play control is raised fully the upper subassembly becomes latched in the up position.

Record Plays

As the record plays, the pickup arm moves inward and the pickup arm lever (7) contacts and gradually rotates the trip lever (20) inward toward the turntable.

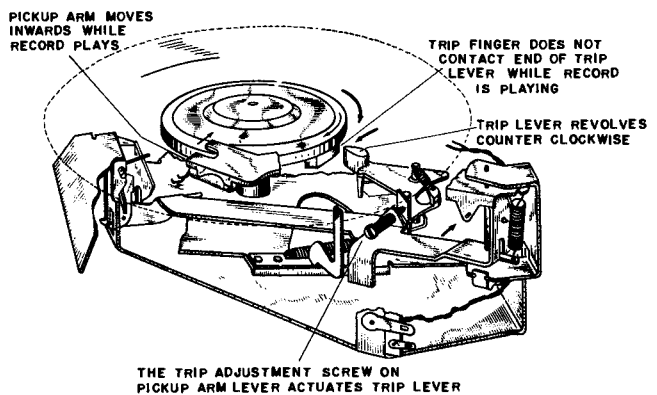
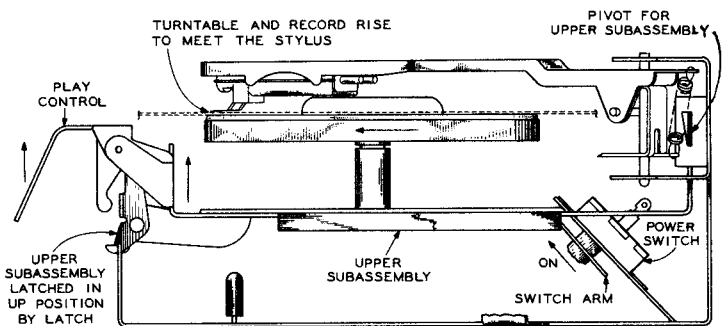

Mechanism Trips

When stylus has moved into finishing grooves of record, the trip lever has rotated sufficiently to make contact with the trip finger extending from the bottom of the rotating turntable. As the two meet, considerable force is transmitted from the rotating turntable to the trip lever. As a result the reject lever (coupled to the trip lever) is actuated and the latch, holding the upper subassembly in the up position, is released.

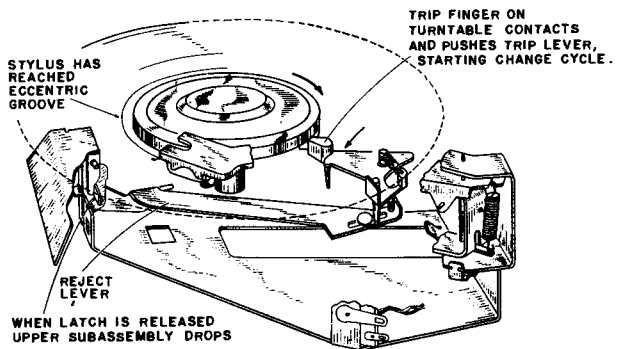

Mechanism Stops Automatically

When the latch is released and the upper subassembly drops, the turntable and record drop away from the pickup stylus. At this time the power switch lever actuates the power switch and the mechanism stops.

The pickup arm is returned to its outermost position (landing position) as a result of a slight push derived from the reject lever return spring directing a force through the trip lever and pickup arm lever assemblies. There is however a tendency for the pickup arm to return to its outermost position because of its weight distribution and its slightly forward tilt.

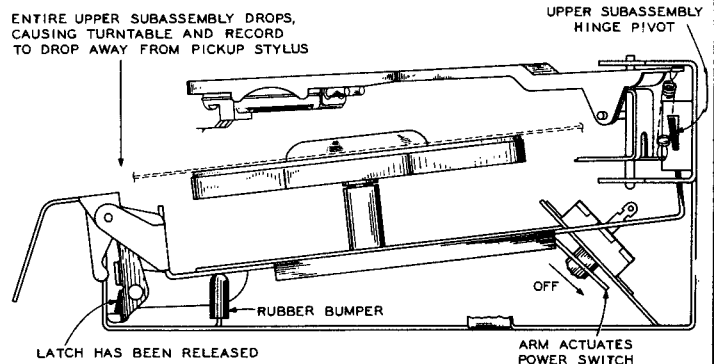

Remove Record

Simply pull the record forward out of the slot in the cabinet to remove it from the mechanism.

RCA Victor Model RP-199 (Continued)

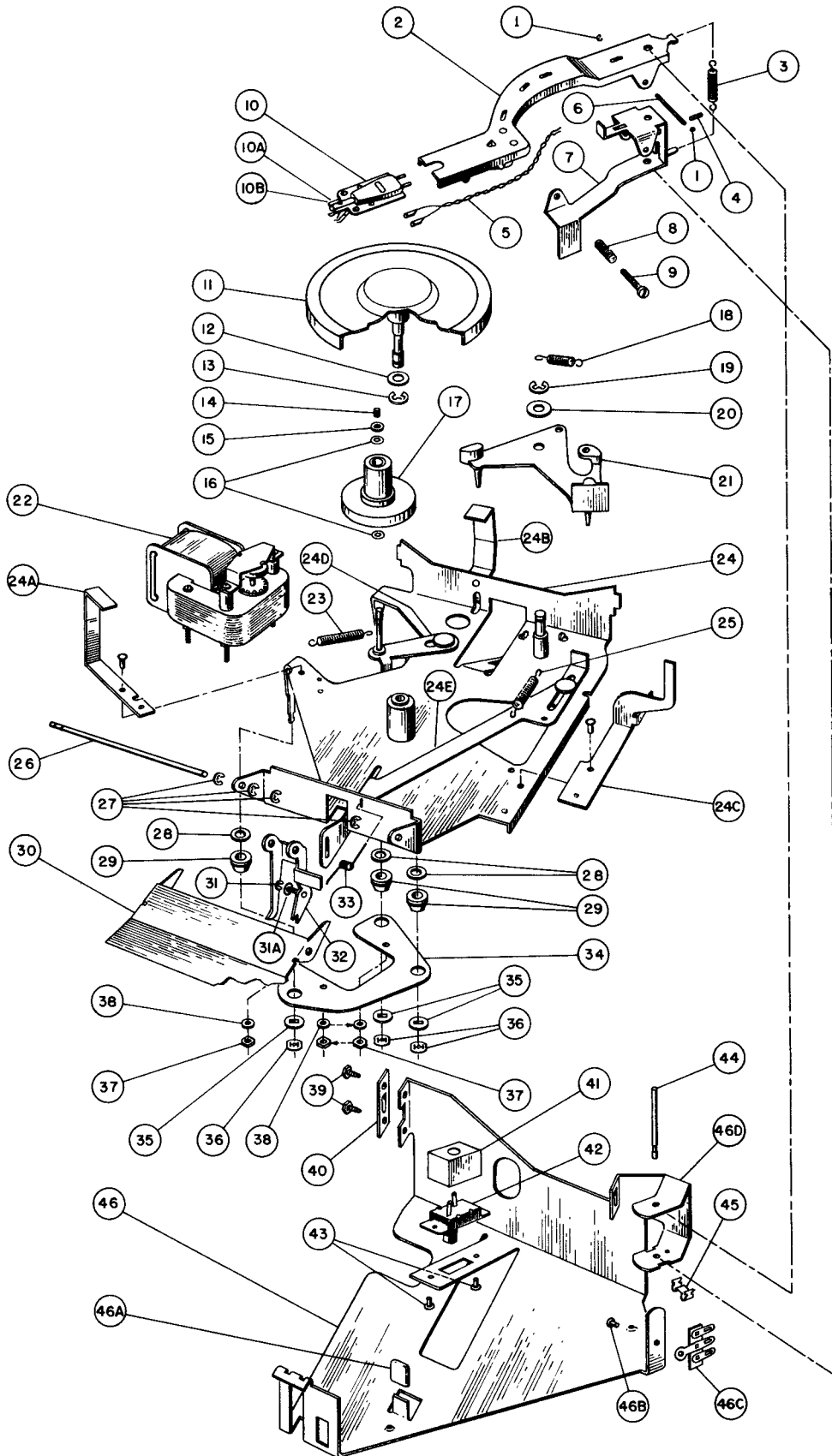

RCA Victor Model RP-199 Record Player (Continued)

REPLACEMENT PARTS

ILL. No.	STOCK No.	DESCRIPTION	ILL. No.	STOCK No.	DESCRIPTION
1	100174	Washer—Retainer, "C" washer for horizontal pickup arm shaft	24E	—	Lever—Reject lever
2	100172	Arm—Pickup arm complete with pickup retainer spring.	25	100192	Spring—Reject lever return spring
3	78698	Spring—Pickup arm counterbalance spring	26	100203	Shaft—Shaft for play control & latch assemblies
4	100200	Screw—Allen set screw for pickup arm horizontal mounting shaft	27	78652	Washer—"C" washer retainer for latch assembly shaft (4 Reqd)
5	100181	Cable—2 conductor pickup cable complete with contacts	28	100202	Washer—Flat washer over motor mounting grommet (3 Reqd)
6	100205	Shaft—Pickup arm horizontal mounting shaft	29	100175	Grommet—Rubber motor mounting grommet (3 Reqd)
7	100207	Lever—Pickup arm lever	30	100189	Latch—Latching assembly (Play Control)
8	100191	Spring—Lock spring for tripping adjustment screw	31	100173	Washer—"C" washer—retainer for latch assembly #32
9	—	Screw—Tripping adjustment screw	31A	100183	Washer—Flat washer for latch assembly
10	74067	Pickup—Crystal pickup cartridge complete with stylus	32	100180	Lever—Latch lever to hold upper subassembly in play position
10A	74230	Hardware—Washer and nut to mount sapphire assembly	33	100182	Spring—Play control tension spring
10B	74068	Stylus—Replacement sapphire stylus and holder for crystal pickup	34	—	Plate—Motor mounting plate
11	100194	Turntable—Turntable complete with shaft	35	100184	Washer—Motor mtg. washer rectangular hole (3 Reqd)
12	100197	Washer—Flat washer for turntable shaft	36	100188	Nut—Speed nut for mounting motor assembly to upper subassembly
13	77586	Washer—"C" washer for turntable shaft	37	—	Nut—Hex nut for mounting motor to motor mounting plate (3 Reqd)
14	100199	Spring—Retainer sleeve for idler wheel	38	—	Lockwasher—Lockwasher for securing motor hex nuts (3 Reqd)
15	100196	Washer—Retainer washer for idler wheel	39	—	Screw—Self tapping screw for mounting hinge plate
16	100198	Washer—Flat washer for idler wheel (fiber) (2 Reqd)	40	100178	Plate—Hinge plate for upper subassembly
17	100176	Wheel—Idler wheel	41	—	Insulator—Switch cover
18	100190	Spring—Trip lever return spring	42	100185	Switch—Power switch complete with insulator (41) and rivets (43)
19	77586	Washer—"C" washer for trip lever shaft	43	—	Rivet—Switch mounting
20	100202	Washer—Flat washer for trip lever complete Ill. No's 29 & 34	44	100204	Shaft—Pickup arm vertical mounting shaft
23	100193	Spring—Idler wheel carriage assembly	45	100179	Bearing—Thrust bearing for pickup arm vertical mounting shaft
21	100195	Lever—Trip lever	46	100209	Plate—Lower subassembly plate complete with Ill. No's 41, 42, 43, 46A, 46B, 46C
22	100206	Motor Assembly—105/125 volts, 60 cycle tension spring	46A	100177	Bumper—Rubber bumper to cushion landing for upper chassis
24	100208	Plate—Upper subassembly plate complete with Ill. No's: 24A, 24B, 24C, 24D, 24E	46B	—	Board—Terminal board for resistor and pickup cable assembly
24A	—	Guide—Record guide			
24B	—	Stop—Record stop			
24C	—	Bracket—Pickup arm bracket			
24D	—	Lever—Idler lever assembly—carriage for idler wheel			

SERVICE HINTS

Fails To Trip

1. Trip adjustment improperly set
2. Limit tab bent out too far
3. Bind in trip slide
4. Defective trip lever
5. Bind in latch bearing
6. Burrs on latch

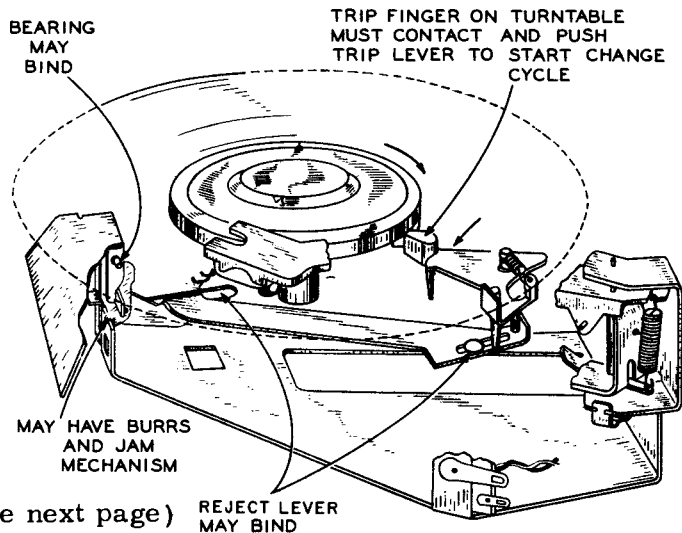
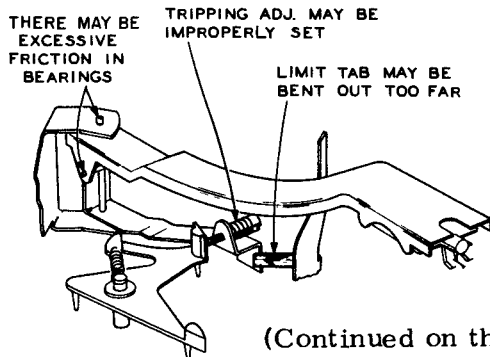

(Continued on the next page)

RCA Victor Model RP-199 (Continued)

SERVICE HINTS (Continued)

Incorrect Landing

1. Outward travel limit tab bent to incorrect position
2. Excessive friction in vertical bearing of pickup arm
3. Thrust bearing may be out of place
4. Counterbalance spring touches pickup arm mounting bracket

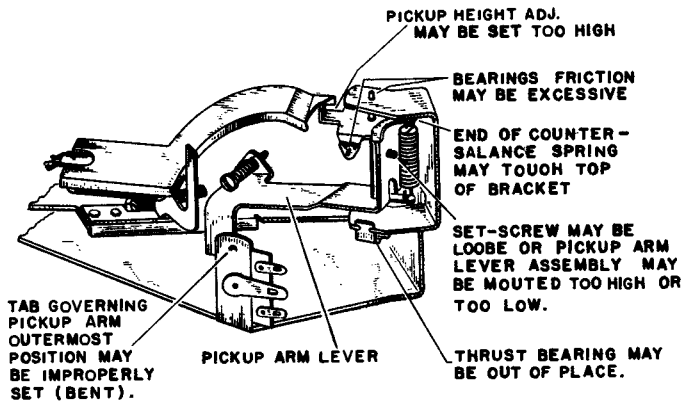

"Wow" and Slow Speed

1. Grease or oil on idler wheel
2. Bind in idler wheel carriage
3. Bind in turntable bearing
4. Insufficient tension in idler carriage spring
5. Excessive stylus pressure

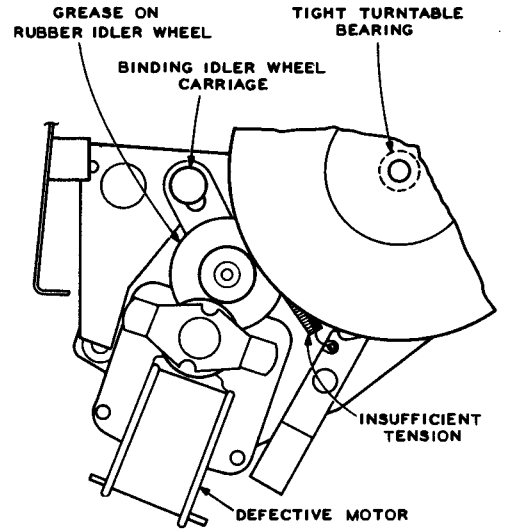

"WOW" MAY ALSO BE CAUSED BY TOO MUCH STYLUS PRESSURE. (THIS WILL CAUSE PREMATURE RECORD WEAR)

Skips Grooves

1. Bind in pickup shaft
2. Height adjustment tab bent up too high
3. Stylus guard bent down too far
4. Pickup arm vertical pivot set too high (counterbalance spring touches bracket)

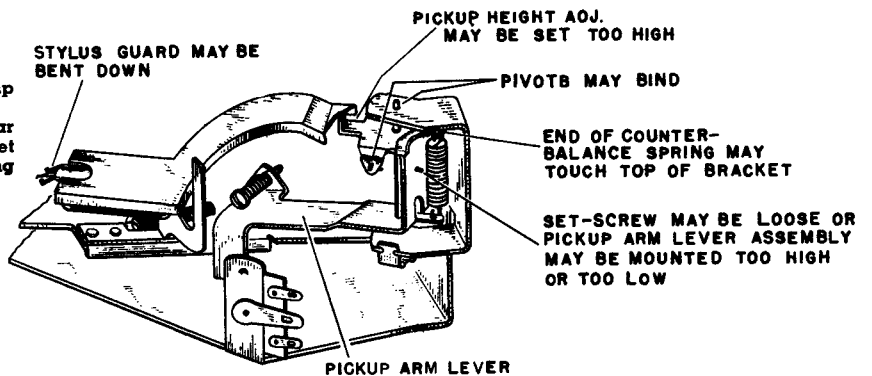

Play Control Will Not Latch

1. Bind in trip slide
2. Trip slide tension spring missing
3. Bind in latch pivot

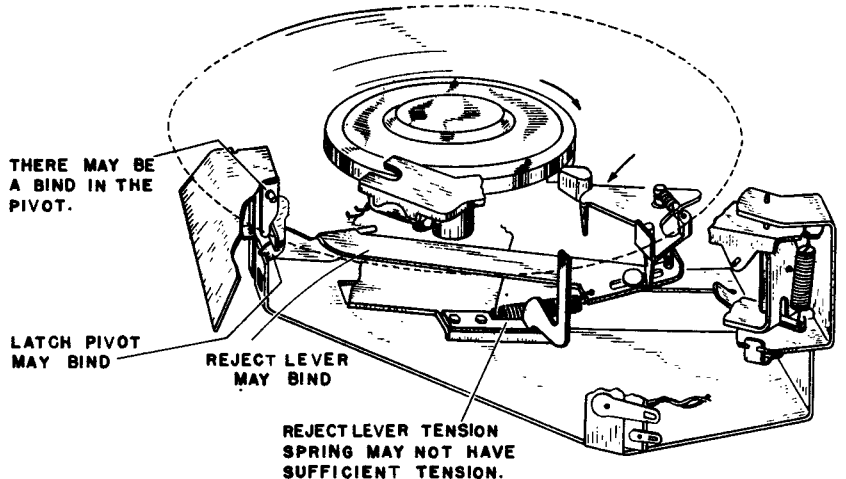

RAYTHEON

MODELS C-50B, C-51W, C-52R
CHASSIS 4D16-A

TURN DRUM COMPLETELY
COUNTERCLOCK-WISE,
RESTRING AS SHOWN.

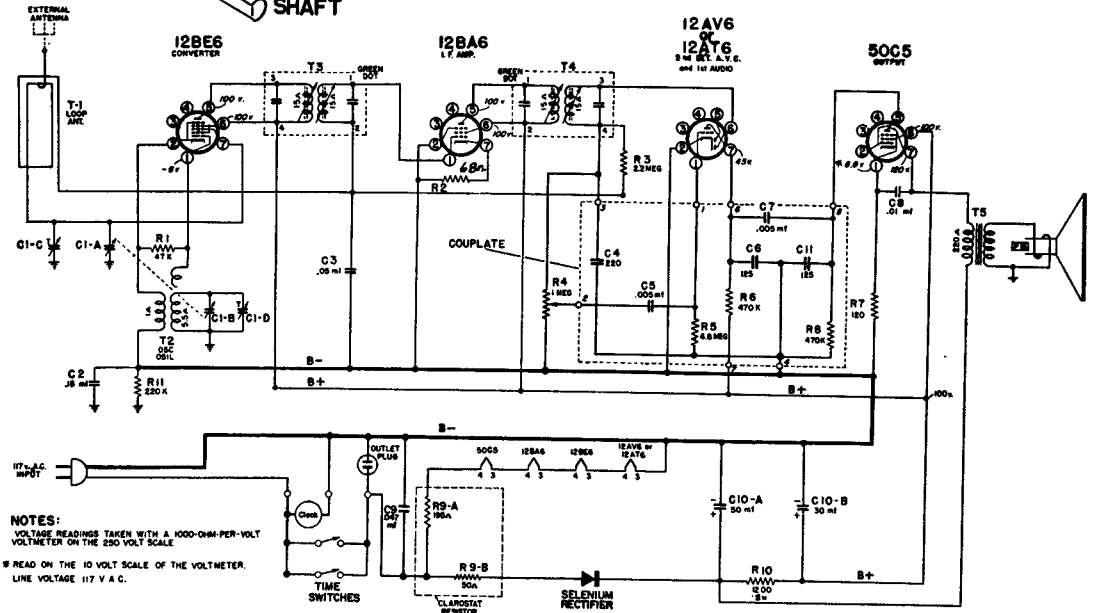
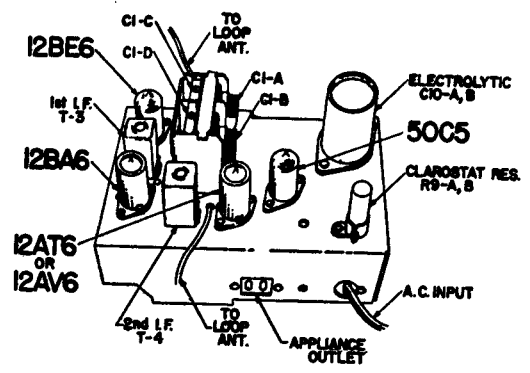
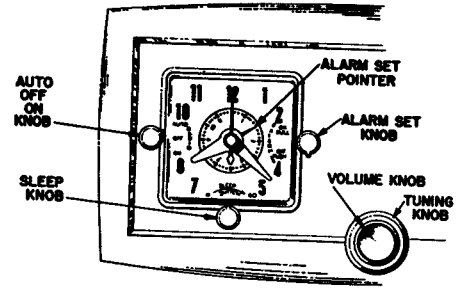
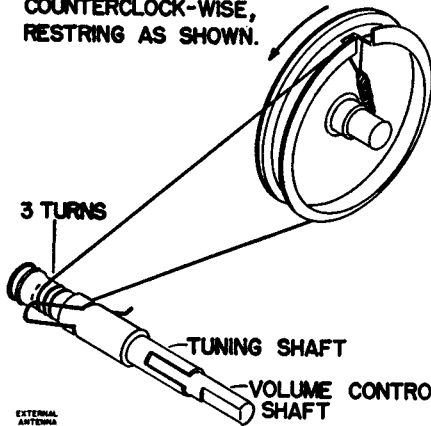

NOTES:
VOLTAGE READINGS TAKEN WITH A 1000-OHM-PER-VOLT
VOLTMETER ON THE 250-VOLT SCALE
* READ ON THE 10 VOLT SCALE OF THE VOLTMETER.
LINE VOLTAGE 117 V A.C.

ALIGNMENT PROCEDURE

• Loop must be connected and volume set to maximum.

SIGNAL GENERATOR				TUNER SETTING	ADJUST FOR MAXIMUM OUTPUT
Frequency	Coupling Capacitor	Connection to Radio	Ground Connection		
455 kc.	.1 mf.	12BE6, Pin 7	HEAVY BUSS LEAD ACROSS CENTER OF CHASSIS	(Capacitor fully open) (plates out of mesh)	Top and bottom Cores in output and input I.F. cans
1620 kc.	.1 mf.	12BE6, Pin 7		(Capacitor fully open) (plates out of mesh)	Oscillator trimmer C1-D on gang
535 kc.	.1 mf.	12BE6, Pin 7		Capacitor fully closed	Check for adequate range
1400 kc.	—	Lay Generator lead near back of cabinet		Tune in 1400 kc. signal	Antenna trimmer C1-C on gang

RAYTHEON MANUFACTURING COMPANY

4RTI CHASSIS

MODELS T-100-1, T-100-2, T-100-3, T-100-4 and T-100-5

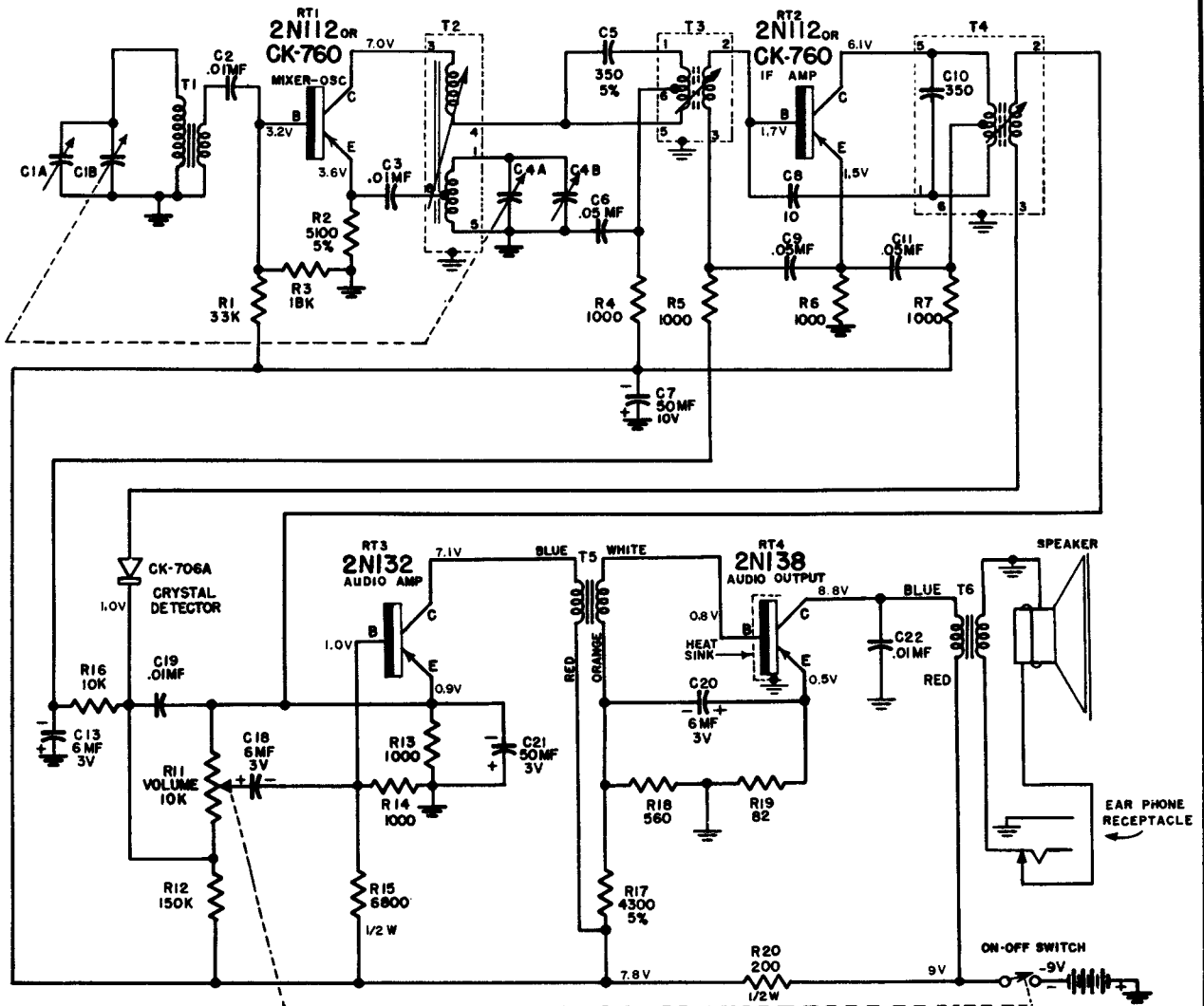

NOTES

RESISTOR VALUES ARE IN OHMS, 1/4 WATT, 10% TOLERANCE, UNLESS OTHERWISE SHOWN.

CAPACITOR VALUES ARE IN MICRO-MICROFARADS. UNLESS OTHERWISE SHOWN. DC WORKING VOLTAGE IS 25V UNLESS OTHERWISE SHOWN.

DC VOLTAGE READINGS TAKEN WITH VTVM, NO SIGNAL IN INPUT AND BATTERY VOLTAGE - 9VDC. VOLTAGES WILL VARY WITH TRANSISTOR CHANGES. ALL VOLTAGES ARE NEGATIVE.

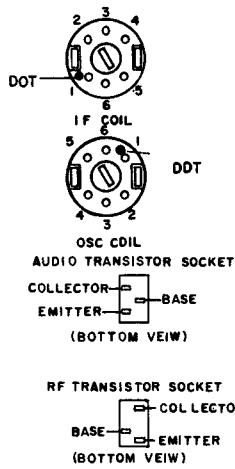
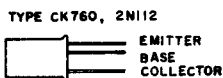
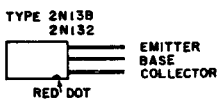

SPEAKER

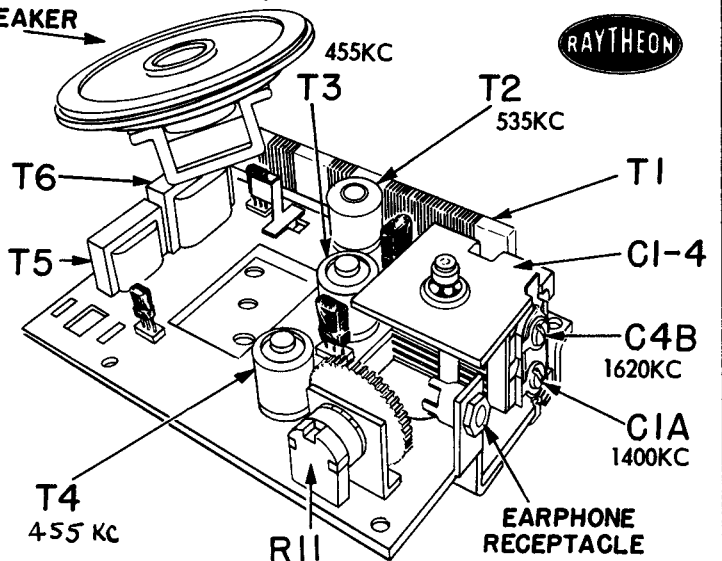

VOLUME R-16, MOST-OFTEN-NEEDED 1956 RADIO

RAYTHEON MANUFACTURING COMPANY

6RT1 CHASSIS

MODELS T-150-1, T-150-2, T-150-3, T-150-4 and T-150-5

ON-OFF
VOLUME

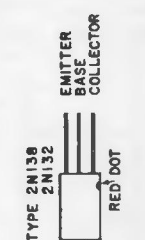
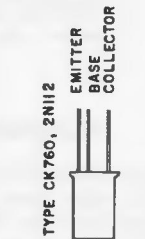
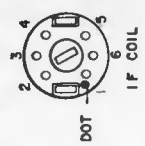
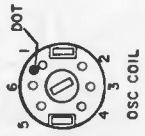
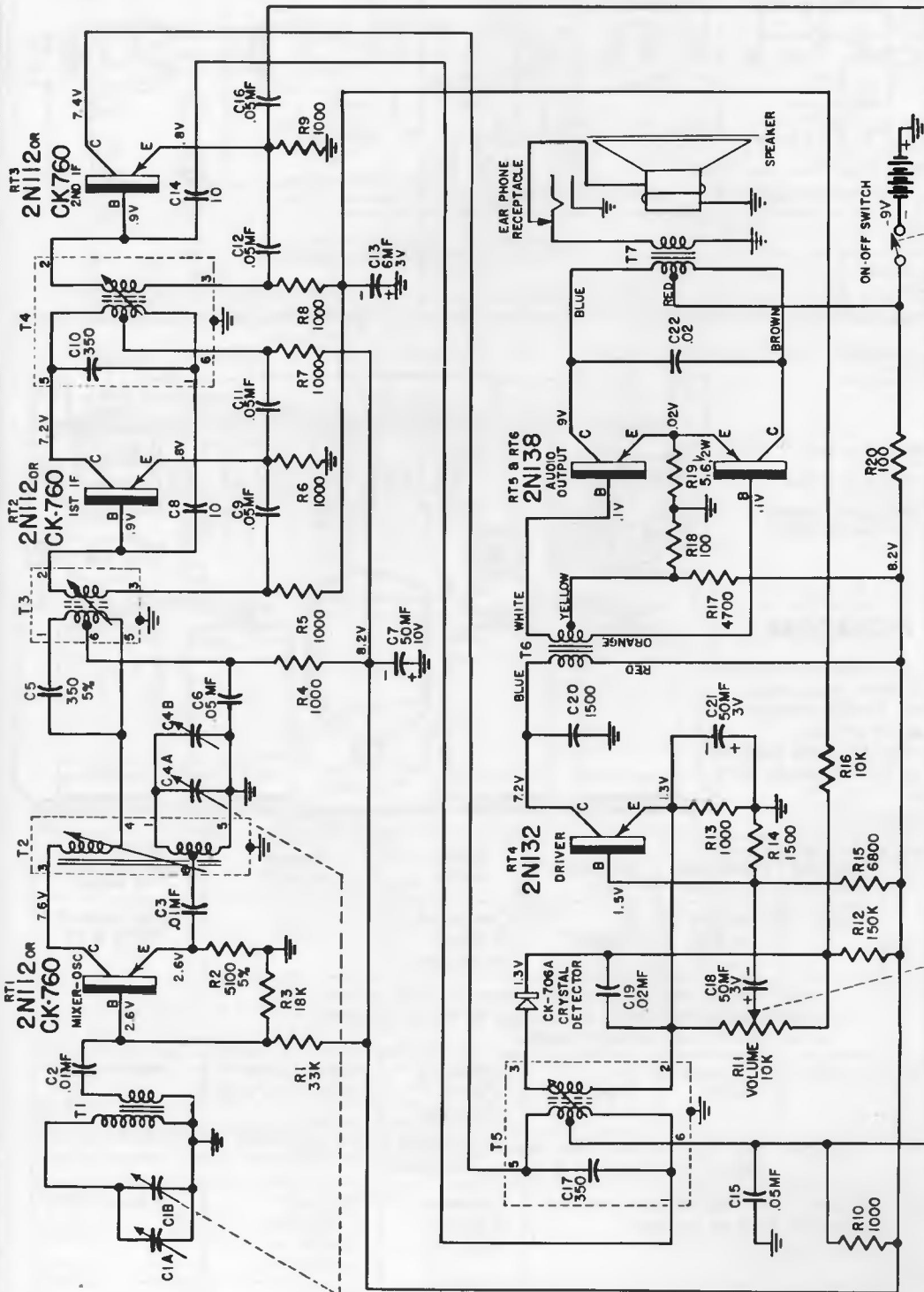
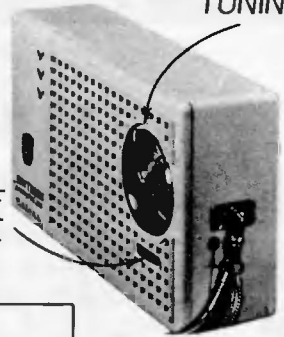

RESISTOR VALUES ARE IN OHMS, 1/4 WATT, 10% TOLERANCE, UNLESS OTHERWISE SHOWN.
CAPACITOR VALUES ARE IN MICRO-MICROFARADS UNLESS OTHERWISE SHOWN DC WORKING VOLTAGE IS 25V UNLESS OTHERWISE SHOWN DC VOLTAGE READINGS TAKEN WITH VTVM, NO SIGNAL IN INPUT AND BATTERY VOLTAGE - 9VDC. VOLTAGES WILL VARY WITH TRANSISTOR CHANGES ALL VOLTAGES ARE NEGATIVE.

RAYTHEON MANUFACTURING COMPANY

8RT1 CHASSIS

MODELS 8TP1, 8TP2, 8TP3 AND 8TP4

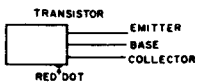
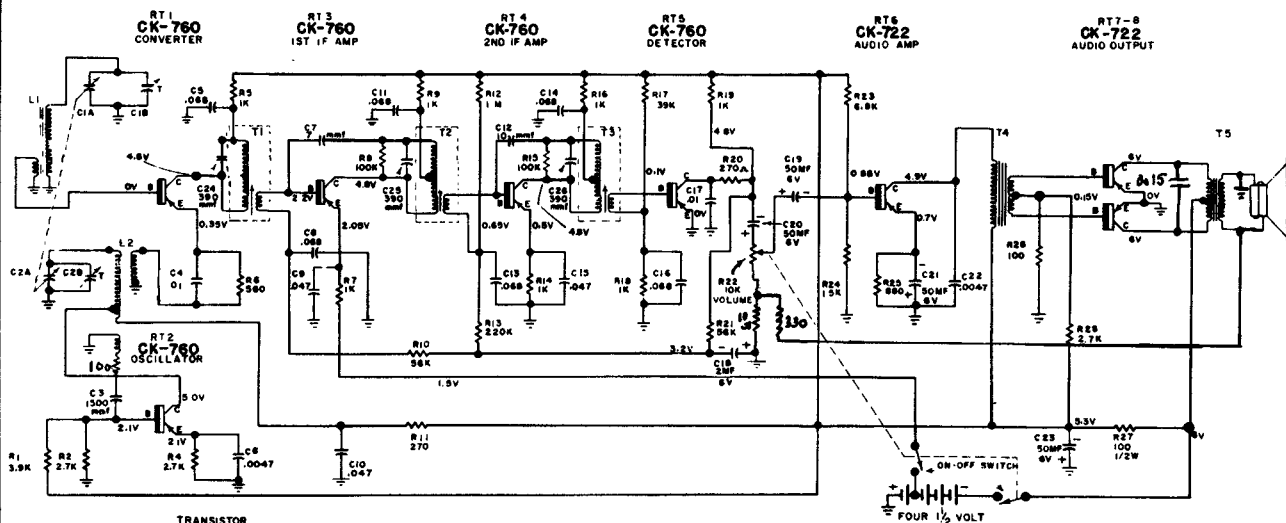

NOTE: UNLESS OTHERWISE SHOWN, RESISTOR VALUES ARE IN OHMS AND ARE 1/2 WATT
 CAPACITOR VALUES ARE IN MICROFARADS UNLESS OTHER OTHERWISE SHOWN
 DC VOLTAGE READINGS TAKEN UNDER NO SIGNAL CONDITIONS WITH BATTERY VOLTAGE - 6VDC. VOLTAGES AT TRANSISTOR SOCKETS WILL VARY SLIGHTLY WITH TRANSISTOR CHANGES.
 USE ONLY VTVM

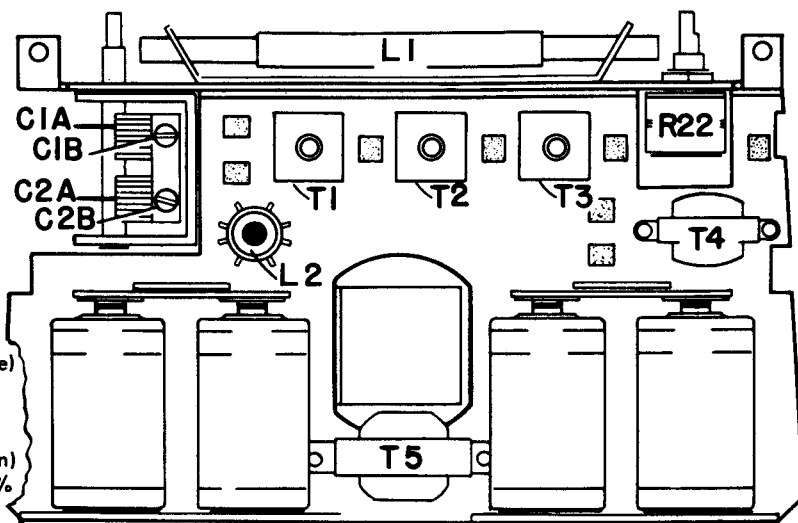

ALIGNMENT PROCEDURE

Turn Volume Control off. (Full counter-clockwise)
 Use output meter with 15 ohms impedance
 Insert four size "D" cells in proper positions.
 (Positive side towards top of chassis)
 Turn Volume Control on. (Full clockwise position)
 Signal generator output of 100 microvolts, 30% modulation at 400 cycles.
 Both knobs must be in place.

SIGNAL GENERATOR					OUTPUT METER	GANGED CAPACITY	ADJUST FOR MAXIMUM OUTPUT IN METER.
	FREQUENCY	COUPLING CAPACITY	CONNECTION TO RADIO	GROUND SIDE			
I.F.	455KC	.5MF.	to Base of RT1	To Chassis	Connected in place of speaker		Top cores of T3, T2 & T1
Repeat above step two or three times for best results, keeping generator output in all cases as low as possible as to prevent overloading of audio.							
Osc.	1620KC	.5MF.	To base of RT1	To Chassis	Connected in place of speaker	Open Gang (Fully clockwise)	Adjust C 2B
Caution: Too high on input from signal generator may cause setting of trimmer on a spurious response.							
Ant.	1400KC.	Connect 3 turn loop to generator and place near loop on receiver.			Connected in place of speaker	Ganged Condenser should be rocked.	Adjust C 1B

Check for alignment and dial calibration at 1000 KC and 600KC.

VOLUME R-16, MOST-OFTEN-NEEDED 1956 RADIO SERVICING INFORMATION

Sears, Roebuck & Co. Chassis 528.40400, Catalog Nos. 6025 and 6026

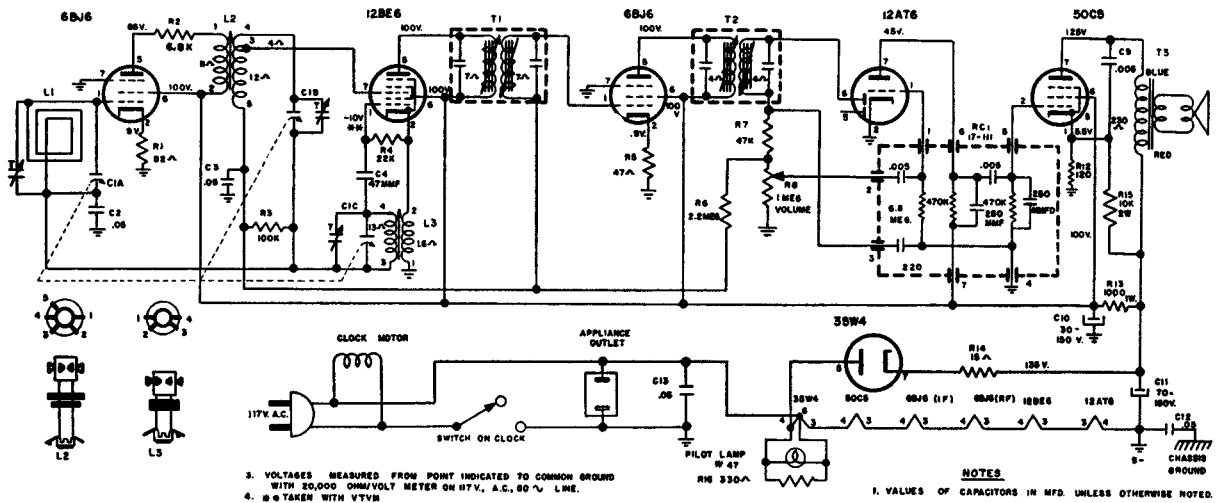

(Alignment information on Chassis 528.40400 is published on the next page, over.)

Sears, Roebuck & Co. Chassis 132.09000, Catalog Nos. 6020 and 6021

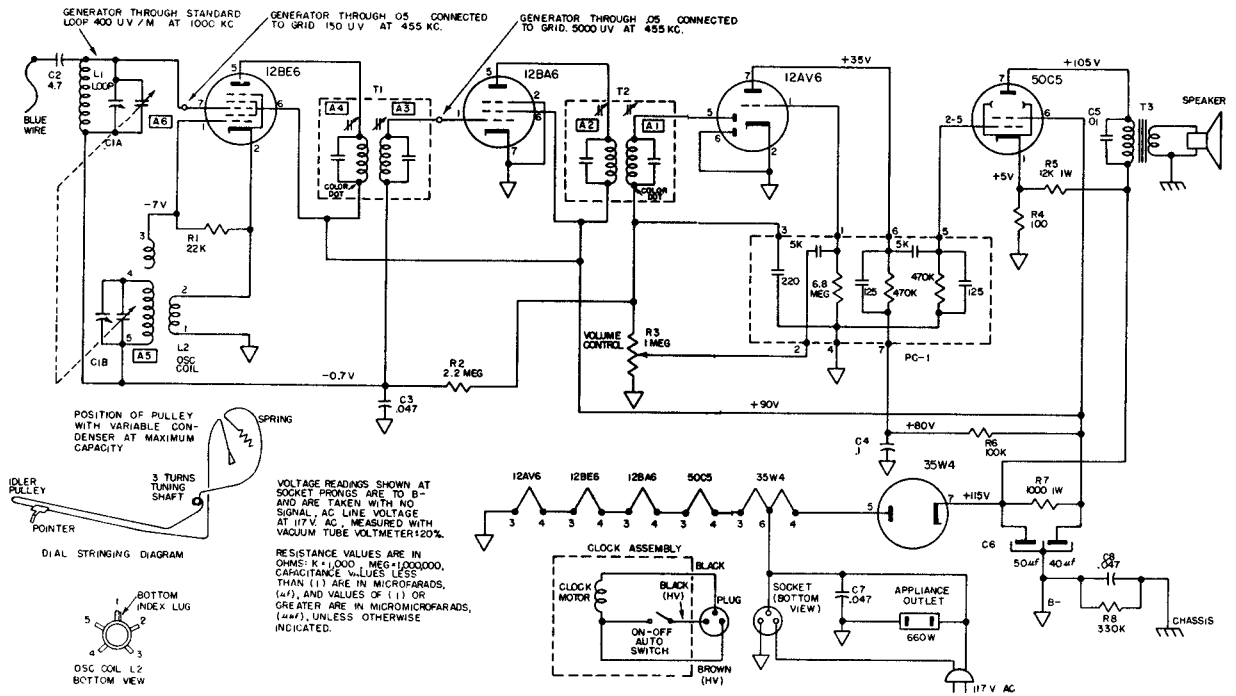

Tuning range 540 Kc. to 1650 Kc. Intermediate frequency - 455 Kc. I-f and r-f measurements made at .5 watt output - approximately 1.26 volts on a rectifier type voltmeter connected across the voice coil. Approximate inputs for .5 watt output; I-f 300 uv. R-f with standard loop; at 600 Kc 800/m; at 1000 Kc 600 uv/m; at 1400 Kc 500 uv/m. For I-f alignment use .05 mfd. as Dummy from Generator hot lead to mixer grid. Connect low side of generator to floating ground. For R-f alignment use radiating loop.

Position of Variable	Generator Frequency	Adj. Trimmers (in order shown)	Trimmer Function
Open	455 Kc	A1, A2, A3, A4	I. F.
1400 Kc	1400 Kc	A5, A6	Osc. Ant.
600 Kc	600 Kc	Check Point	

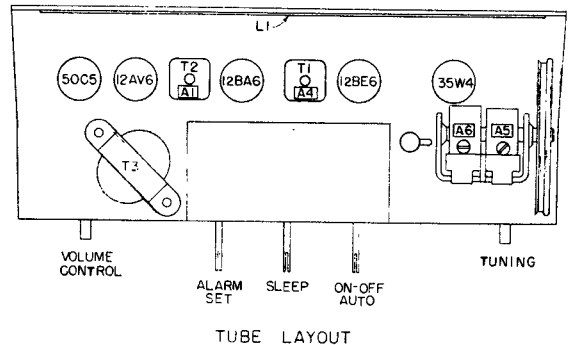

VOLUME R-16, MOST-OFTEN-NEEDED 1956 RADIO SERVICING INFORMATION

Sears, Roebuck & Co. Chassis 528.40500, Catalog Nos. 6056A and 6057A

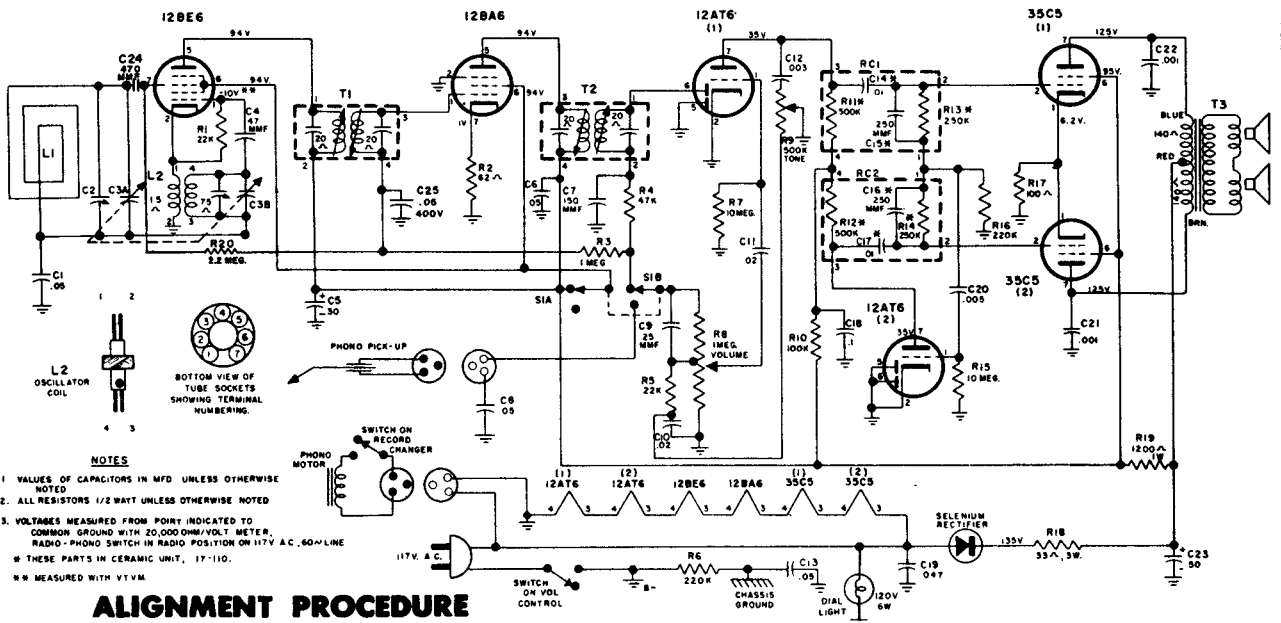

ALIGNMENT PROCEDURE

POSITION OF TUNER	GENERATOR FREQUENCY	DUMMY ANTENNA	GENERATOR CONNECTION	TRIMMER ADJUSTMENT	TRIMMER FUNCTION
open	455 KC	.1 mfd.	pin 7 12BE6	T1 and T2 top and bottom	I.F.
open	1630 KC	.1 mfd.	pin 7 12BE6	C3B	Oscillator
1400 KC	1400 KC	HAZELTINE TEST LOOP		C2*	Antenna

* Located an Antenna.

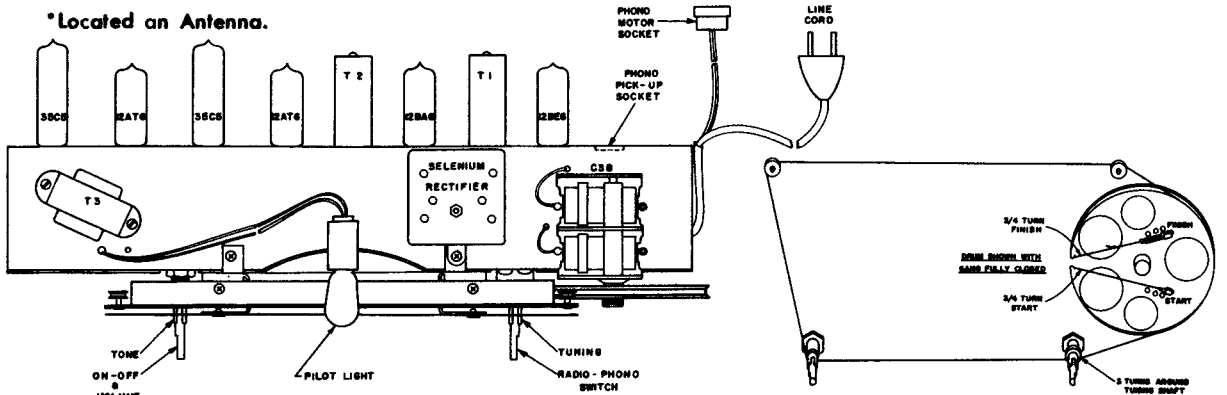

Alignment Information for Chassis 528.40400 (see preceding page for circuit)

POSITION OF TUNER	GENERATOR FREQUENCY	DUMMY ANTENNA	GENERATOR CONNECTION	TRIMMER FUNCTION	TRIMMER ADJUSTMENT
Open	455 KC	0.1 mfd.	12BE6 pin 7	T2 (top & bottom)	2nd I.F.
Open	455 KC	0.1 mfd.	pin 7 12BE6	T1 (top & bottom)	1st I.F.
Open	1610 KC	0.1 mfd.	pin 7 12BE6	C1C (trimmer)	Oscillator
1400 KC	1400 KC	Hazeltine test loop		C1B (trimmer)	R.F.
1400 KC	1400 KC	Hazeltine test loop		C1A (trimmer)	Antenna

Sentinel Radio

MODEL 359P

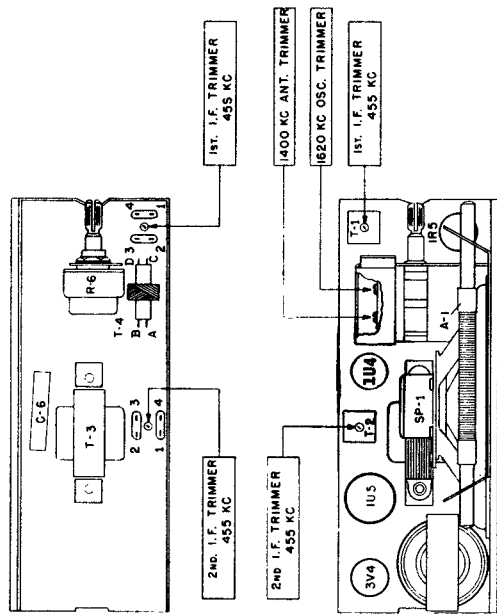
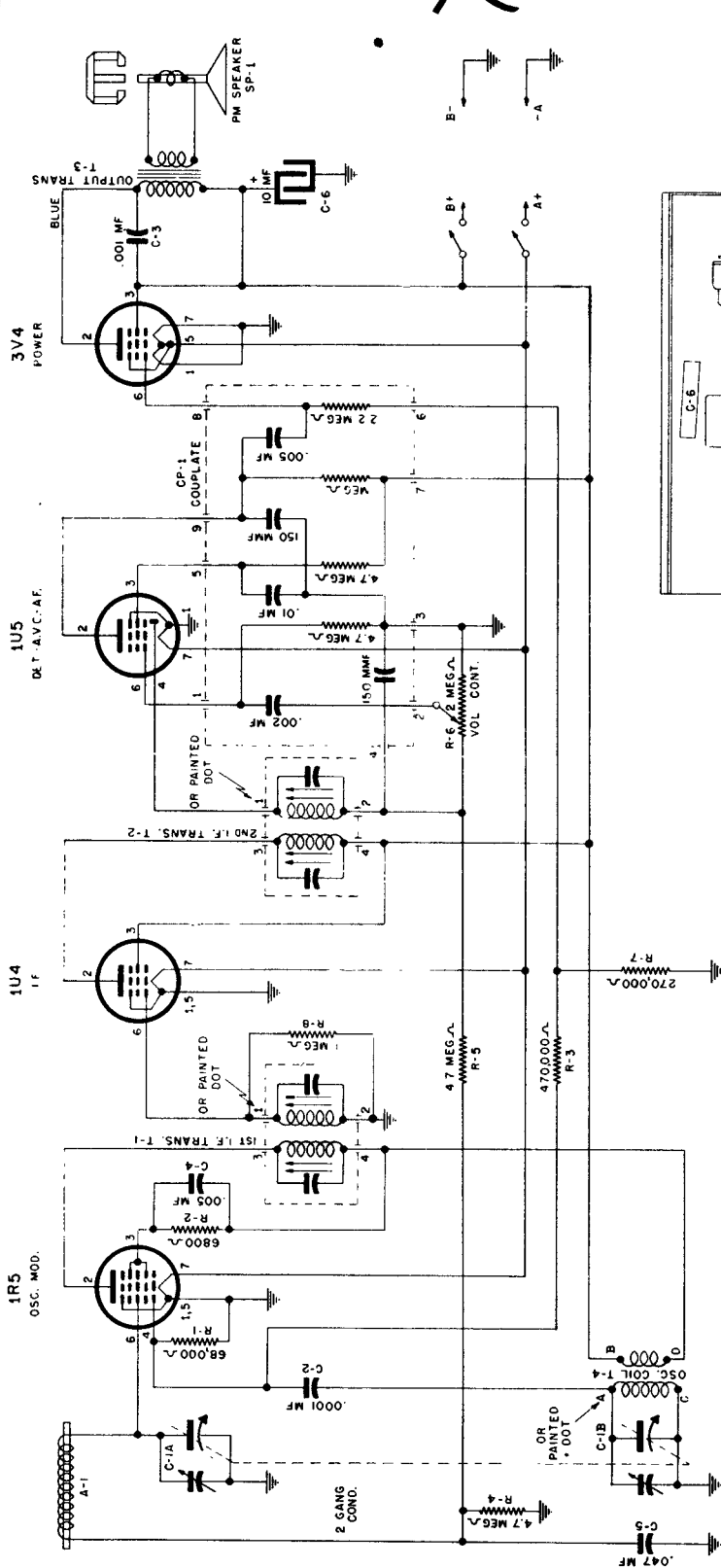

I.F. - 455 KC.

SENTINEL RADIO CORPORATION

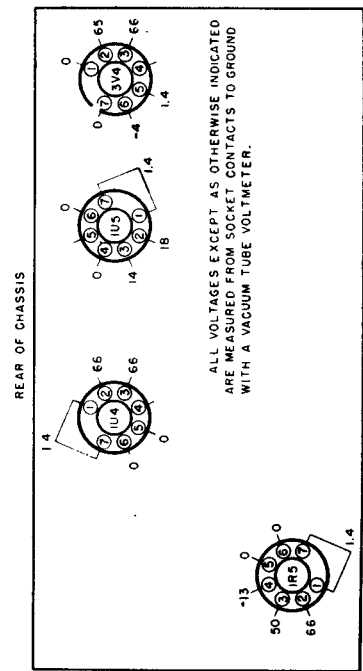

VOLTAGE TABLE
(BOTTOM VIEW OF CHASSIS)

Sentinel Radio

MODEL 1U-360

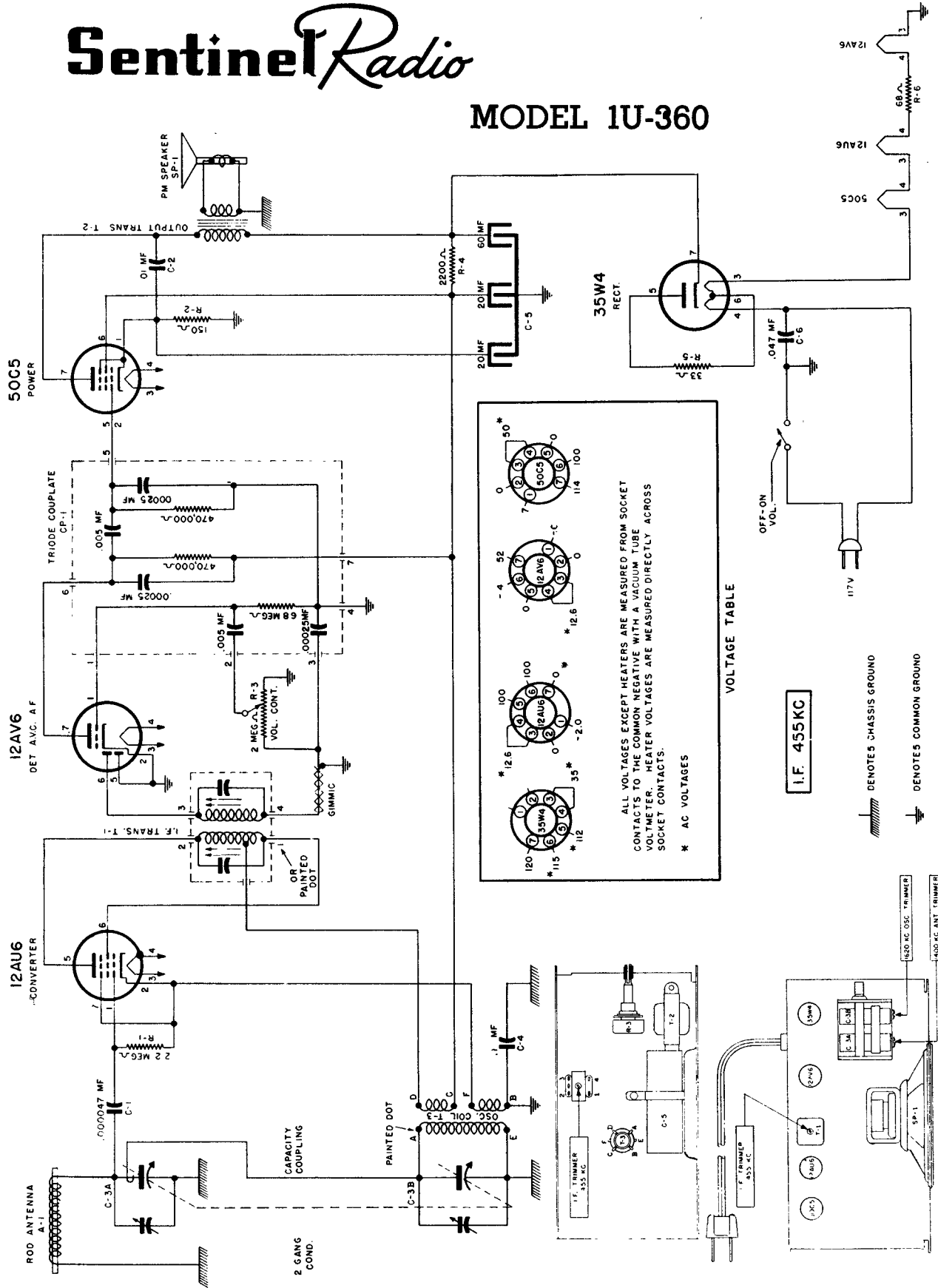

Sentinel Radio

MODEL 1U-363

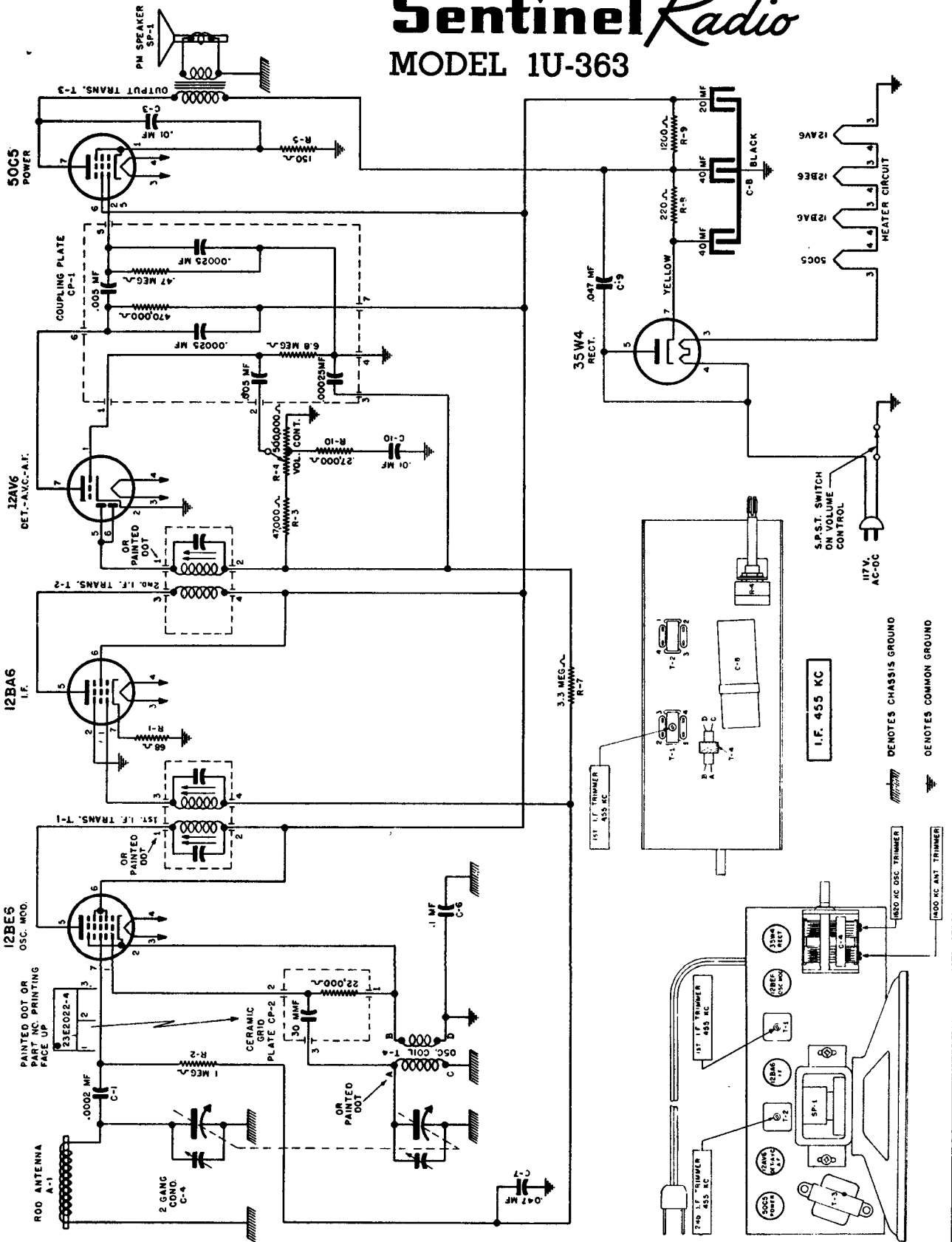

Sentinel MODEL 1U-364

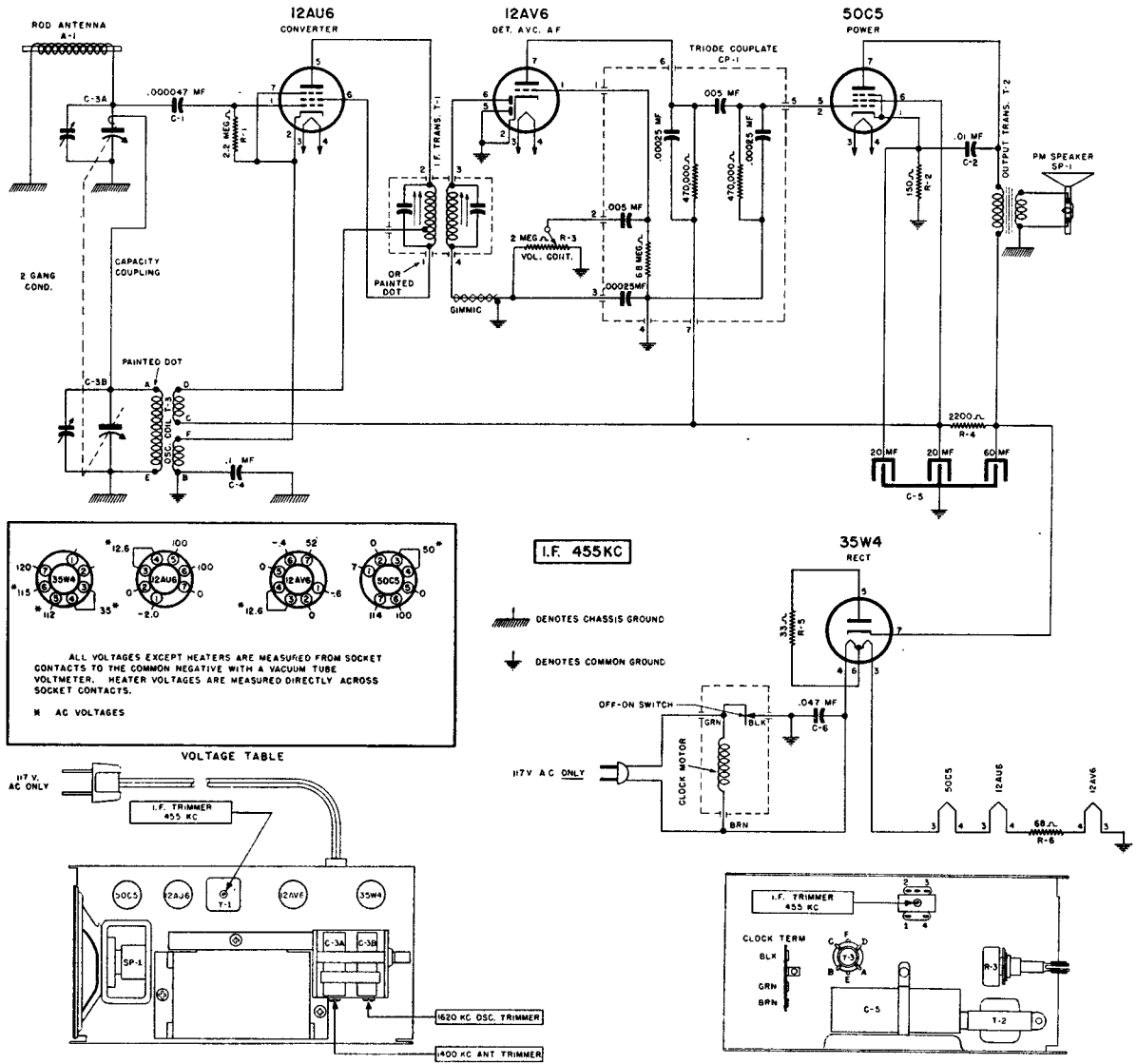

ALIGNMENT PROCEDURE

Use an accurately calibrated test oscillator with some type of output measuring device. When aligning the I.F. slugs use a non-metallic screwdriver.

(A) When aligning the 1620 KC OSCILLATOR TRIMMER or the 1400 KC ANTENNA TRIMMER, couple test oscillator to receiver antenna by: (1) make loop consisting of five to ten turns of NO. 20 to NO. 30 size wire, wound on a 2" to 3" form; (2) connect this loop across output of test oscillator; (3) place test oscillator loop near radio antenna.

Steps	Set receiver dial to:	TEST OSCILLATOR			Refer to parts layout diagram for location of trimmers mentioned below:
		Adjust test oscillator frequency to:	Use dummy antenna in series with output of test oscillator consisting of:	Attach output of test oscillator to:	
1	Any point where no interfering signal is received.	455 K.C.	.02 MFD. condenser	High side to antenna stator plates of tuning condenser. Low side to common negative.	Adjust each of the I.F. transformer slugs for maximum output.
2	Exactly 1620 K.C.	Exactly 1620 K.C.	See paragraph (A) above.	See paragraph (A) above.	Adjust 1620 K. C. oscillator trimmer for maximum output.
3	Approx. 1400 K.C.	Approx. 1400 K.C.	See paragraph (A) above.	See paragraph (A) above.	Adjust 1400 K. C. antenna trimmer for maximum output.

Sentinel

MODEL IU-365

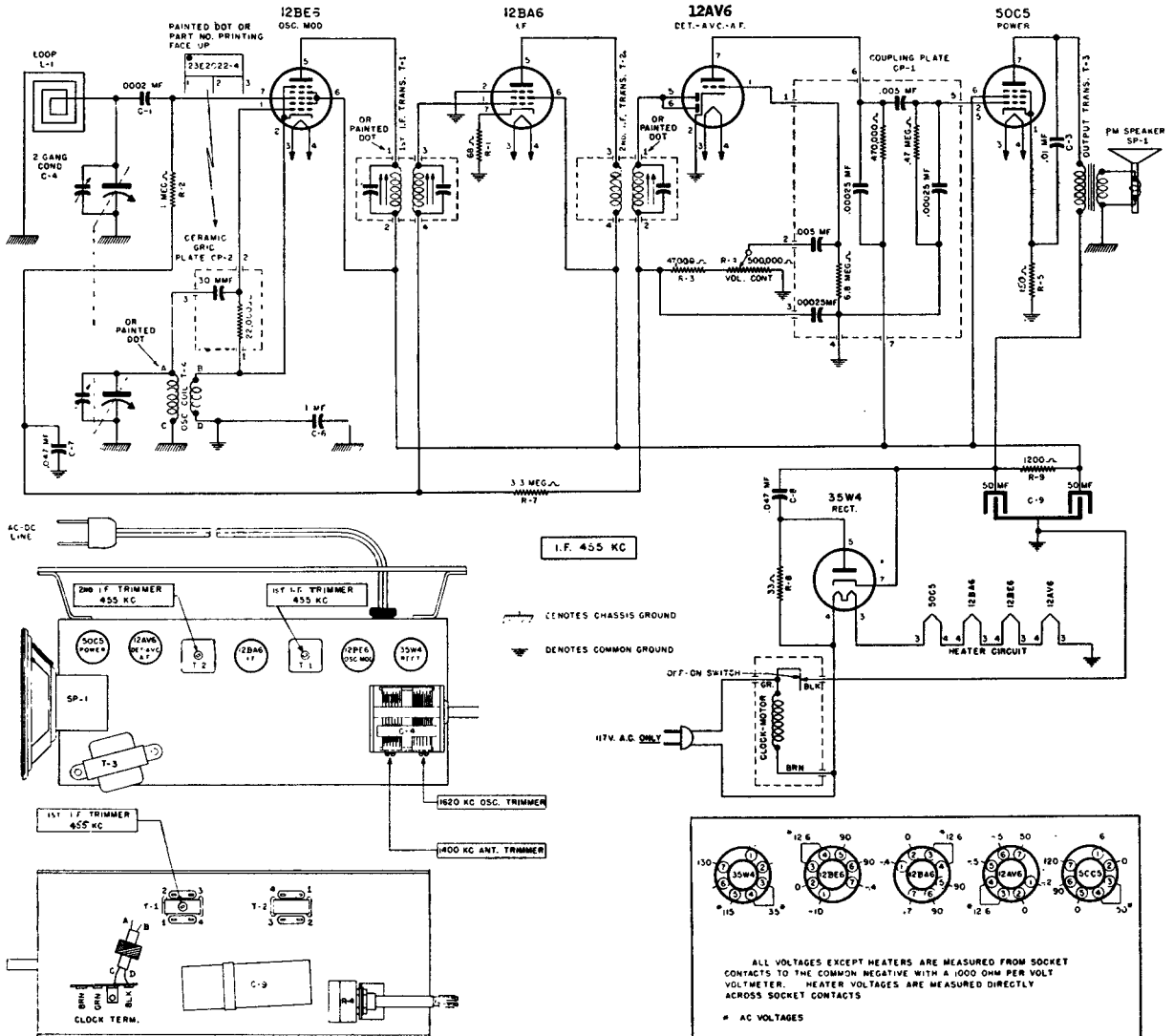

ALIGNMENT PROCEDURE

VOLTAGE TABLE
(BOTTOM VIEW OF CHASSIS)

When the chassis is removed from the cabinet the loop must be mounted on the loop mounting brackets, and the two wires connected to the loop.

(A) When aligning the 1620 KC OSCILLATOR TRIMMER or the 1400 KC ANTENNA TRIMMER, couple test oscillator to receiver loop by: (1) make loop consisting of five to ten turns of NO. 20 to NO. 30 size wire, wound on a 2" to 3" form; (2) connect this loop across output of test oscillator; (3) place test oscillator loop near radio loop. BE SURE THAT NEITHER LOOP MOVES WHILE ALIGNING.

Steps	Set receiver dial to:	TEST OSCILLATOR			Refer to parts layout diagram for location of trimmers mentioned below:
		Adjust test oscillator frequency to:	Use dummy antenna in series with output of test oscillator consisting of:	Attach output of test oscillator to:	
1	Any point where no interfering signal is received.	455 K.C.	.02 MFD. condenser	High side to antenna stator plates of tuning condenser. Low side to common negative.	Adjust the second I.F. transformer slug for maximum output—then adjust each of the first I.F. slugs for maximum output.
2	Exactly 1620 K.C.	Exactly 1620 K.C.	See paragraph (A) above.	See paragraph (A) above.	Adjust 1620 K.C. oscillator trimmer for maximum output.
3	Approx. 1400 K.C.	Approx. 1400 K.C.	See paragraph (A) above.	See paragraph (A) above.	Adjust 1400 K.C. antenna trimmer for maximum output.

VOLUME R-16, MOST-OFTEN-NEEDED 1956 RADIO SERVICING INFORMATION

SYLVANIA Electric Products, Inc. Models 515, 519, 5151, Chassis 1-607-1, -2, -3

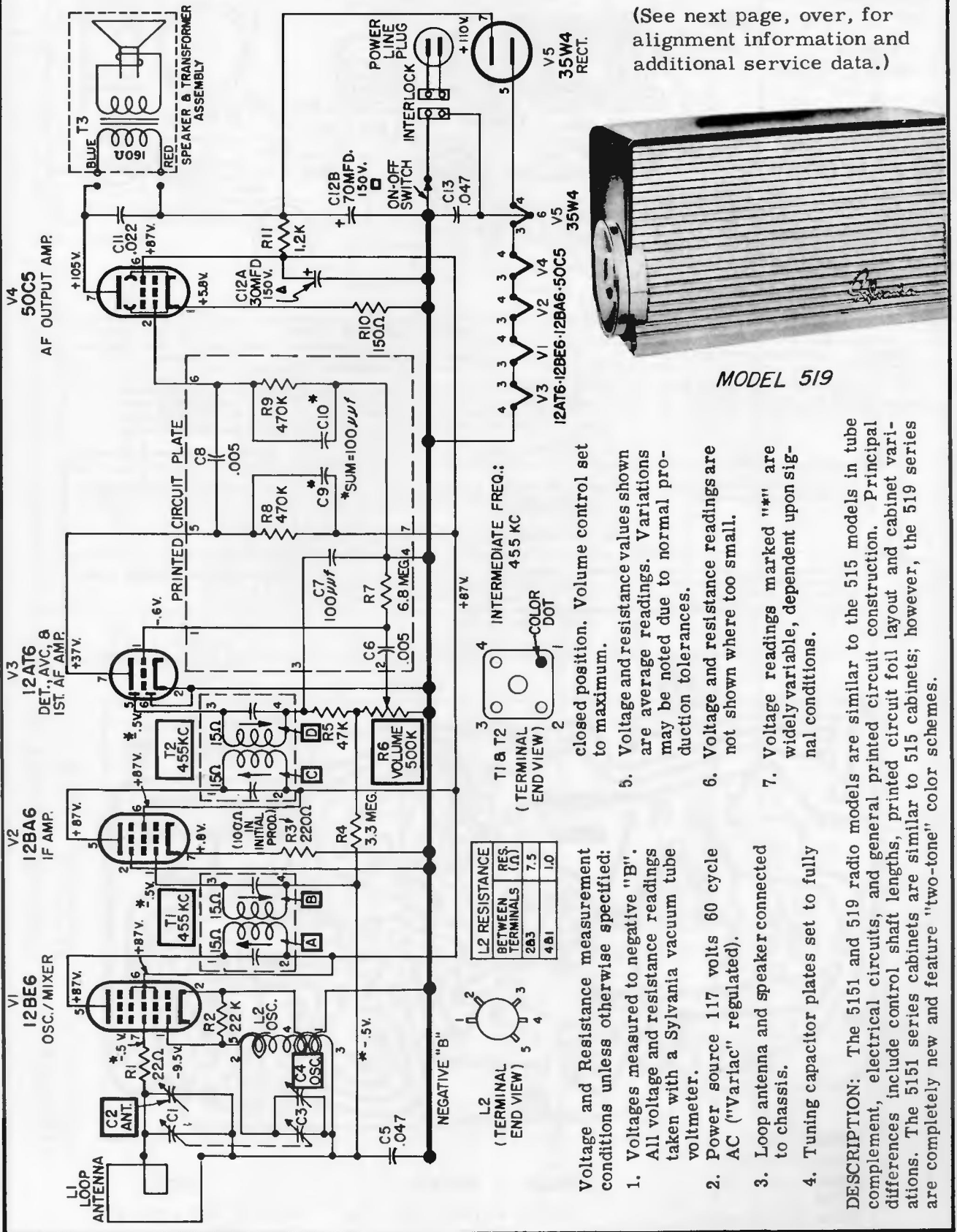

(See next page, over, for alignment information and additional service data.)

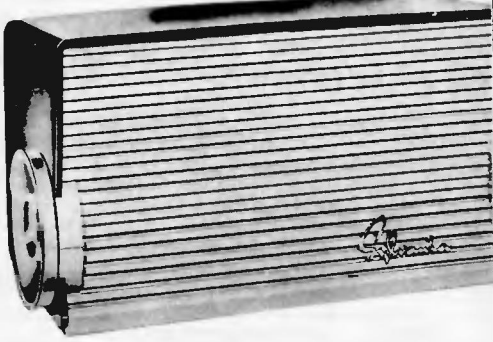

MODEL 519

5. Voltage and resistance values shown are average readings. Variations may be noted due to normal production tolerances.
6. Voltage and resistance readings are not shown where too small.
7. Voltage readings marked "*" are widely variable, dependent upon signal conditions.

L2 RESISTANCE BETWEEN TERMINALS	RES. (Ω)
2-3	7.5
4-5	1.0

1. Voltages measured to negative "B". All voltage and resistance readings taken with a Sylvania vacuum tube voltmeter.
2. Power source 117 volts 60 cycle AC ("Variac" regulated).
3. Loop antenna and speaker connected to chassis.
4. Tuning capacitor plates set to fully closed position. Volume control set to maximum.

DESCRIPTION: The 5151 and 519 radio models are similar to the 515 models in tube complement, electrical circuits, and general printed circuit construction. Principal differences include control shaft lengths, printed circuit foil layout and cabinet variations. The 5151 series cabinets are similar to 515 cabinets; however, the 519 series are completely new and feature "two-tone" color schemes.

VOLUME R-16, MOST-OFTEN-NEEDED 1956 RADIO SERVICING INFORMATION

SYLVANIA

Models 515,
519, and 5151,
Chassis
1-607-1, -2, -3

(Continued from
preceding page
on other side.)

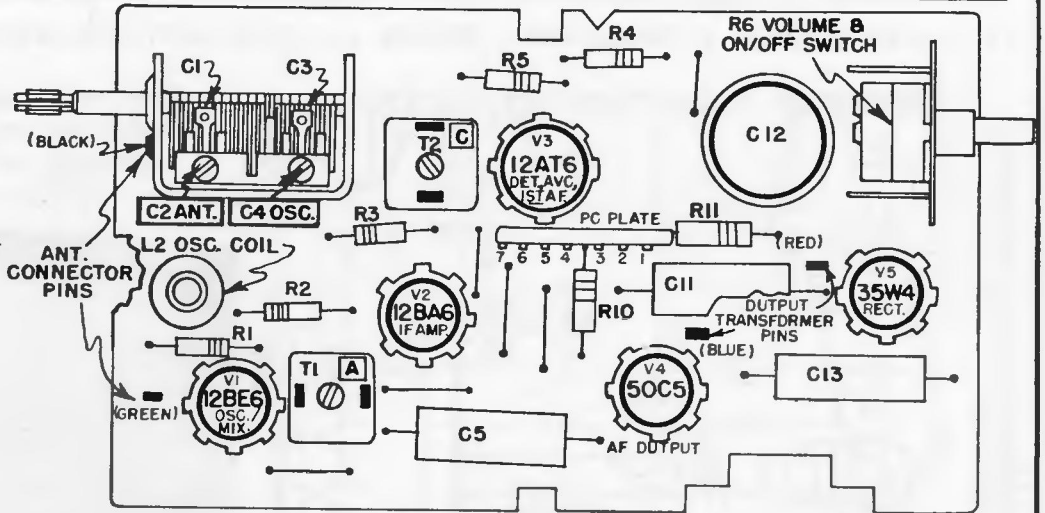

PARTS LAYOUT - TOP

STEP	ALIGNMENT SETUP NOTES	TEST EQUIPMENT HOOKUP	ADJUST
1.	Set variable tuning capacitor plates fully open (minimum capacity).	SIGNAL GENERATOR - "hot" lead through .1 mfd. capacitor to junction of R1 (22 ohm) and pin 7 of V1 (12BE6); ground lead to 12BA6 tube shield (negative "B"). Set generator to 455 KC. AC VOLTMETER - across speaker voice coil.	T2-D for MAXIMUM output. T2-C for MAXIMUM output. T1-B for MAXIMUM output. T1-A for MAXIMUM output. REPEAT for optimum performance.
2.	Set variable tuning capacitor plates fully open (minimum capacity).	SIGNAL GENERATOR - radiate signal to receiver through a loop of several turns of wire. Set generator to 1650 KC. AC VOLTMETER - across speaker voice coil.	C4 trimmer for MAXIMUM output.
3.	Set variable tuning capacitor plates so plates are meshed approximately 3/16 inch. Adjust this setting slightly to eliminate any interfering signals.	SIGNAL GENERATOR - radiate signal to receiver through a loop of several turns of wire. Set generator to a frequency corresponding to receiver tuning capacitor setting (until signal is heard through receiver speaker). AC VOLTMETER - across speaker voice coil.	C2 trimmer for MAXIMUM output.

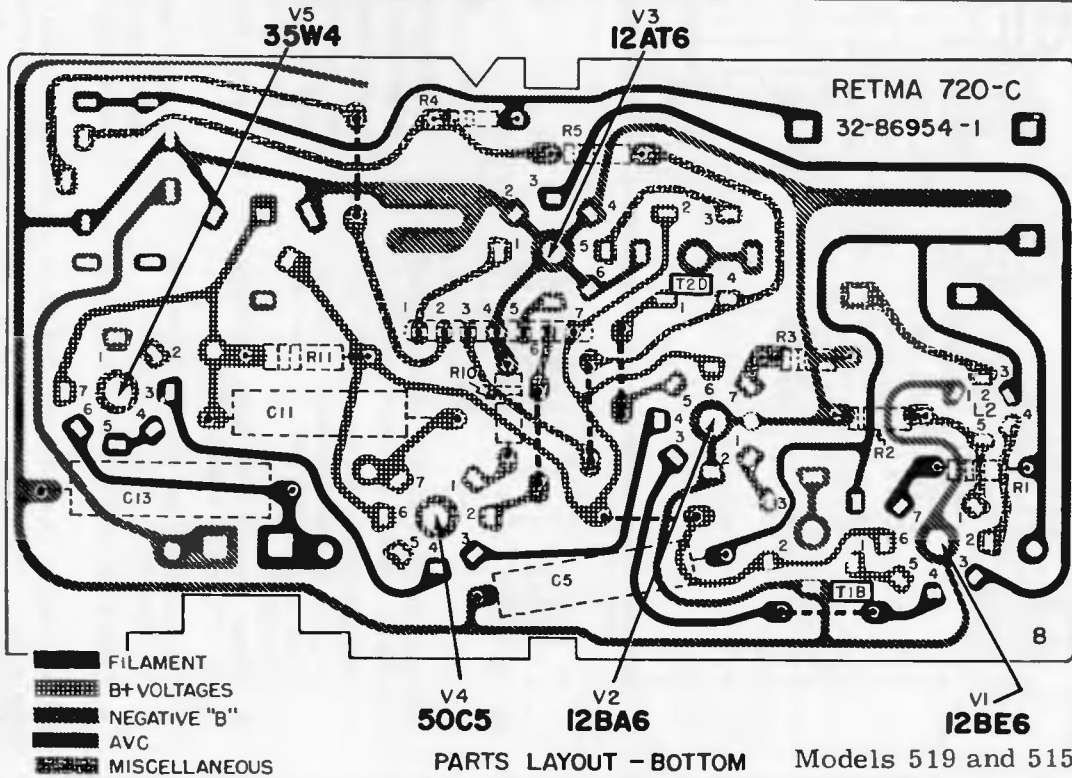

PARTS LAYOUT - BOTTOM

Models 519 and 5151

SYLVANIA Chassis 1-607-4, Model 1102

(For alignment data and basic chassis printed wiring refer to preceding page, material for 1-607-1.)

CHASSIS: 1-607-4 (For alignment information and basic printed wiring refer to preceding page, material for 1-607-1, etc.)
 MODELS: 1102

CHASSIS: 1-607-4
 MODELS: 1102

SYLVANIA
 RADIO & TELEVISION

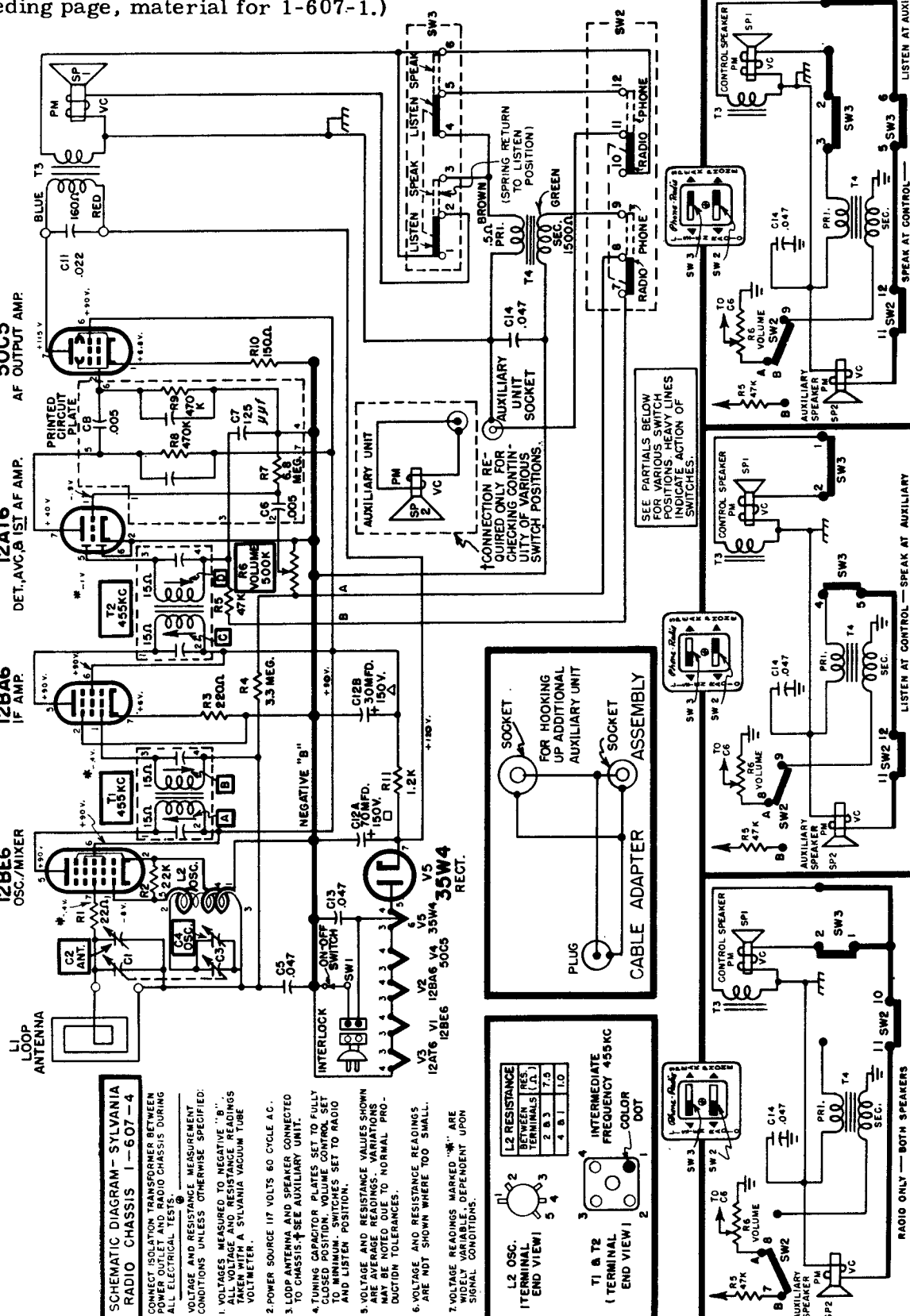

SCHMATIC DIAGRAM - SYLVANIA RADIO CHASSIS 1-607-4

CONNECT ISOLATION TRANSFORMER BETWEEN POWER OUTLET AND RADIO CHASSIS DURING ALL ELECTRICAL TESTS.

VOLTAGE AND RESISTANCE MEASUREMENT CONDITIONS UNLESS OTHERWISE SPECIFIED:

1. VOLTAGES MEASURED TO NEGATIVE "B". ALL VOLTAGE AND RESISTANCE READINGS USING A SYLVANIA VACUUM TUBE VOLTMETER.
2. POWER SOURCE 117 VOLTS 60 CYCLE A.C.
3. LOOP ANTENNA AND SPEAKER CONNECTED TO CHASSIS. SEE AUXILIARY UNIT.
4. TUNING CAPACITOR PLATES SET TO FULLY CLOSED POSITION. VOLUME CONTROL SET TO MINIMUM. SWITCHES SET TO RADIO AND LISTEN POSITION.
5. VOLTAGE AND RESISTANCE VALUES SHOWN ARE AVERAGE READINGS. VARIATIONS MAY BE NOTED DUE TO NORMAL PRODUCTION TOLERANCES.
6. VOLTAGE AND RESISTANCE READINGS ARE NOT SHOWN WHERE TOO SMALL.
7. VOLTAGE READINGS MARKED "*" ARE WIDELY VARIABLE - DEPENDENT UPON SIGNAL CONDITIONS.

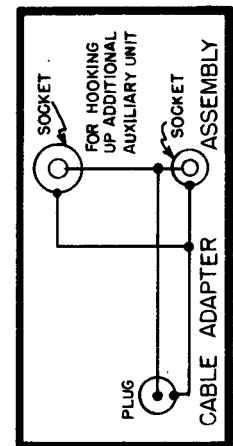
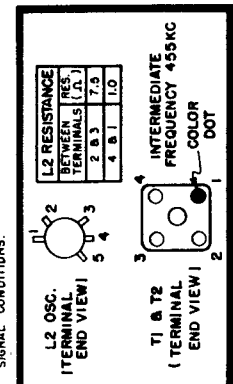

SEE PARTIALS BELOW FOR VARIOUS SWITCH POSITIONS. HEAVY LINES INDICATE ACTION OF SWITCHES.

SYLVANIA Electric Products
(Alignment on next page at right)

CHASSIS: 1-610-1, 1-611-1
MODELS: 3201 SERIES; 3302 SERIES

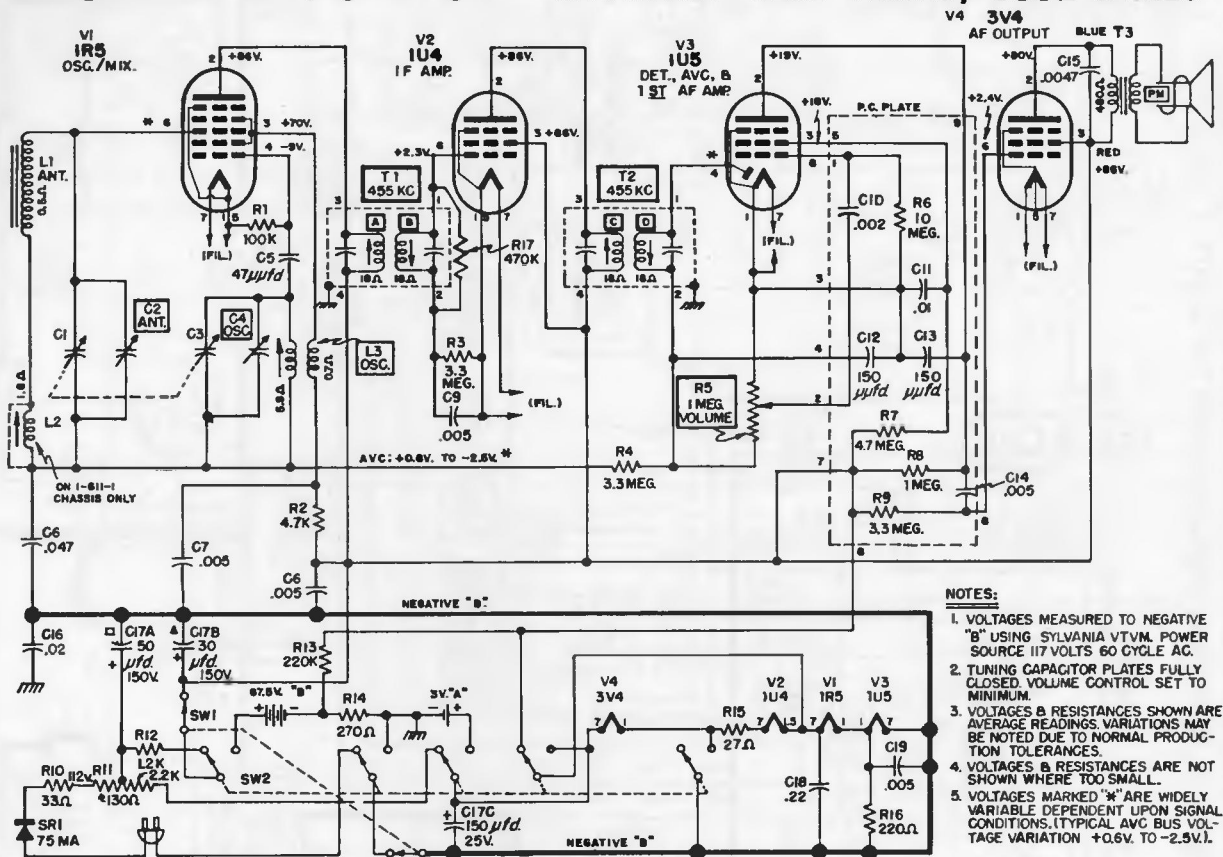

CHASSIS REMOVAL

1. Remove Station Selector knob.
2. ON MODEL 3201 ONLY, remove back cover as follows:
 - a. Insert a pencil or any similar object into the hole in center of cabinet bottom.
 - b. Depress the spring catch by means of the pencil or similar object and lift back cover simultaneously.
3. ON MODEL 3302 ONLY, open back cover by pushing up on slide catch on rear of cabinet.

4. Remove "A" battery connectors from cabinet mountings.
5. ON MODEL 3302 ONLY, disengage line cord retainer on side of cabinet and remove antenna connector pins on inside top of cabinet.
6. Remove three (3) chassis mounting screws shown in appropriate sketch below.
7. Remove chassis from cabinet by shifting chassis slightly toward cabinet bottom and simultaneously by lifting chassis from cabinet.

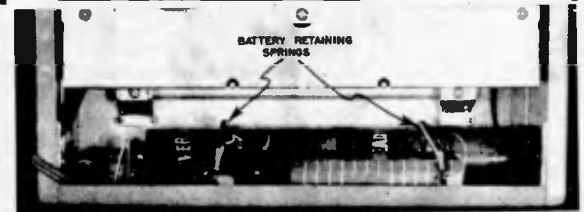
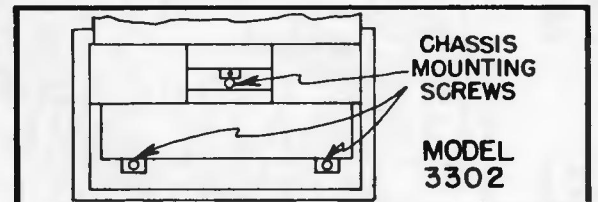
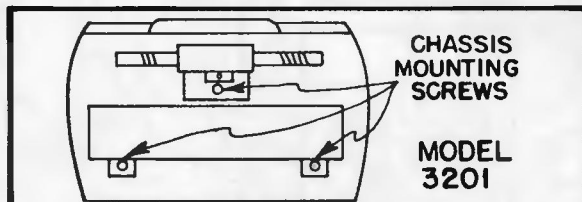

VOLUME R-16, MOST-OFTEN-NEEDED 1956 RADIO SERVICING INFORMATION

SYLVANIA

Chassis 1-610-1, 1-611-1,
Models 3201, 3302.

(Circuit diagram and other service material on the preceding page at left.)

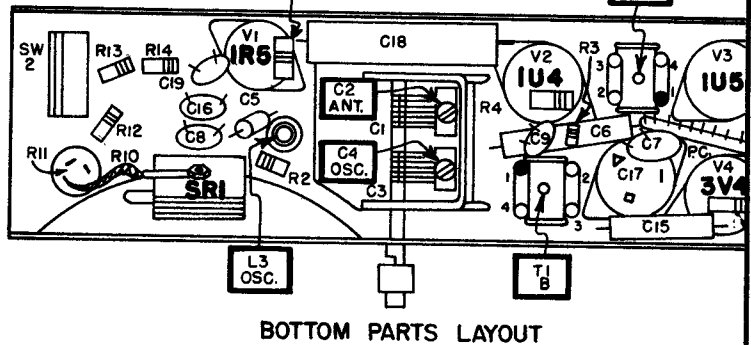
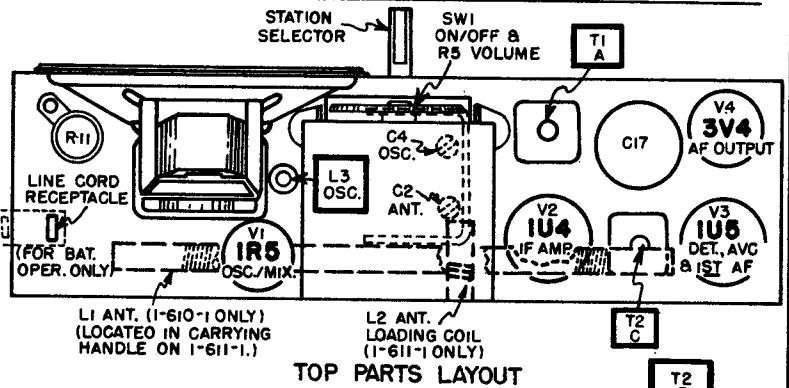

ALIGNMENT PROCEDURE

Remove radio chassis from cabinet. On Model 3302, remove handle and antenna assembly and connect to chassis.

Set signal generator for an RF output signal amplitude modulated (AM) by 400 cycles.

Use either an audible check or an AC voltmeter connected across speaker voice coil to indicate output.

Adjust Volume control to full volume.

STEP	ALIGNMENT SET-UP NOTES	TEST EQUIPMENT HOOK-UP	ADJUST
1.	Set variable tuning capacitor plates fully closed (maximum capacity).	SIGNAL GENERATOR - "hot" lead through .1 mfd. capacitor to pin 6 of V1 (1R5); ground lead to negative "B". Set generator to 455 KC. AC VOLTMETER - across speaker voice coil.	T2-D for MAXIMUM output. T2-C for MAXIMUM output. T1-B for MAXIMUM output. T1-A for MAXIMUM output. REPEAT for optimum performance.
2.	Set variable tuning capacitor plates fully open (minimum capacity).	SIGNAL GENERATOR - "hot" lead through .1 mfd. capacitor to pin 6 of V1 (1R5); ground lead to negative "B". Set generator to 1620 KC.	C4 for MAXIMUM output.
3.	Set variable tuning capacitor plates so plates are meshed approximately 3/16 inch. Adjust this setting slightly to eliminate any interfering signals.	SIGNAL GENERATOR - radiate signal to receiver through a loop of several turns of wire. Set generator to a frequency corresponding to receiver tuning capacitor setting (until signal is heard through receiver speaker).	C2 for MAXIMUM output.
4.	Set variable tuning capacitor plates fully closed (maximum capacity).	SIGNAL GENERATOR - "hot" lead through .1 mfd. capacitor to pin 6 of V1 (1R5); ground lead to negative "B". Set generator to 540 KC.	L3 for MAXIMUM output.
5.	Repeat step 3.		

TRAVLER

MODEL 9064

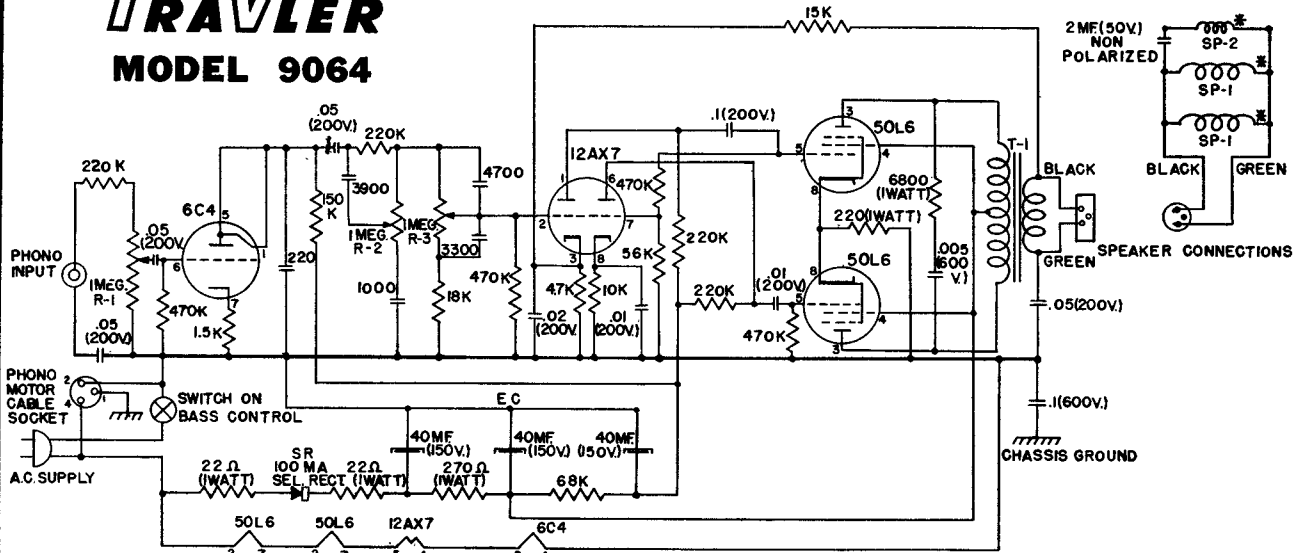

NOTES:

1. # INDICATES START OF VOICE COIL MARKED BY RED DOT, REVERSE PHASING WILL CAUSE LOSS OF BASS.
2. REVERSE PHASING OF FEEDBACK WILL CAUSE AMPLIFIER TO OSCILLATE.
3. POLARIZE A.C. PLUG FOR MINIMUM HUM.
4. RESISTORS TO BE 1/2 WATT UNLESS OTHERWISE SHOWN.
5. CAPACITORS TO BE IN MMF. IF SMALLER THAN .005 MF.

SYMBOL	PART NO.	DESCRIPTION
R-1	VC-46	1 MEGOHM CONTROL AUDIO TAPER.
R-2	VC-45	1 MEGOHM CONTROL LINEAR TAPER.
R-3	VC-44	1 MEGOHM CONTROL LINEAR TAPER WITH S.P.S.T. SWITCH.
EC	EC-29	40-40-40 @ 150 W.V. ELECTROLYTIC.
SR	SR-4	100 MA. SELENIUM RECTIFIER.
T-1	AT-12	PUSH PULL-OUTPUT TRANSFORMER.

MODEL 6514

ALIGNMENT DATA

FIRST STEP: Connect the hot lead from the generator to the ANT. section of the gang condenser through a .1 MFD. condenser. The ground lead from the generator must be connected to "B" minus under the chassis. Turn the gang condenser to complete minimum capacity. Set the generator to 455 KC. Adjust the movable iron cores in the IF cans.

SECOND STEP: With the leads from the generator still connected as in IF alignment, adjust the generator to 1610 KC. Make sure that the gang condenser is turned to complete minimum capacity. Adjust the generator to 1610 KC. and adjust the oscillator trimmer of the receiver until the signal is tuned in. Next, turn the gang condenser to complete maximum capacity. Adjust the generator to 540 KC., then adjust the iron core in the end of the oscillator coil until the signal is tuned in.

THIRD STEP: Remove the generator leads from the gang condenser and the chassis. Loosely couple the generator to the antenna by laying the hot generator lead near the antenna rod. Set the generator at 1400 KC. and tune in the 1400 KC. signal on the receiver. Adjust the ANT. trimmer until a maximum signal is noted on the output meter.

FIRST STEP: Connect the hot lead from the generator to the ANT. section of the gang condenser through a .1 MFD. condenser. The ground lead from the generator must be connected to "B" minus under the chassis. Turn the gang condenser to complete minimum capacity. Set the generator to 455 KC. Adjust the movable iron cores in the IF cans.

SECOND STEP: With the leads from the generator still connected as in IF alignment, adjust the generator to 1610 KC. Make sure that the gang condenser is turned to complete minimum capacity. Adjust the generator to 1610 KC. and adjust the oscillator trimmer of the receiver until the signal is tuned in. Next, turn the gang condenser to complete maximum capacity. Adjust the generator to 540 KC., then adjust the iron core in the end of the oscillator coil until the signal is tuned in.

THIRD STEP: Remove the generator leads from the gang condenser and the chassis. Loosely couple the generator to the antenna by laying the hot generator lead near the antenna rod. Set the generator at 1400 KC. and tune in the 1400 KC. signal on the receiver. Adjust the ANT. trimmer until a maximum signal is noted on the output meter.

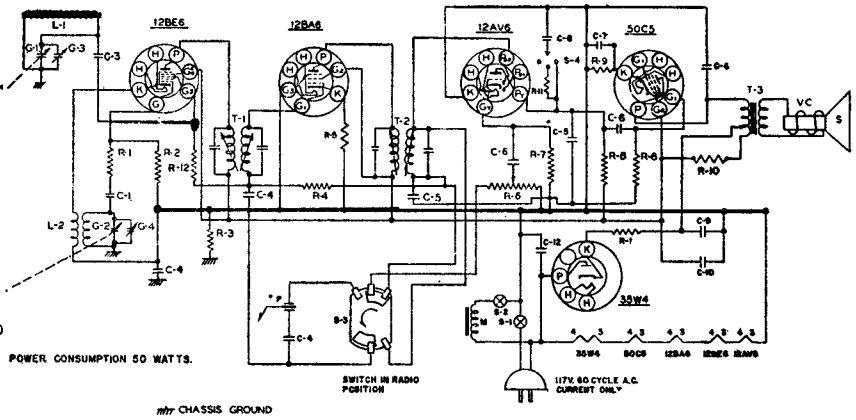
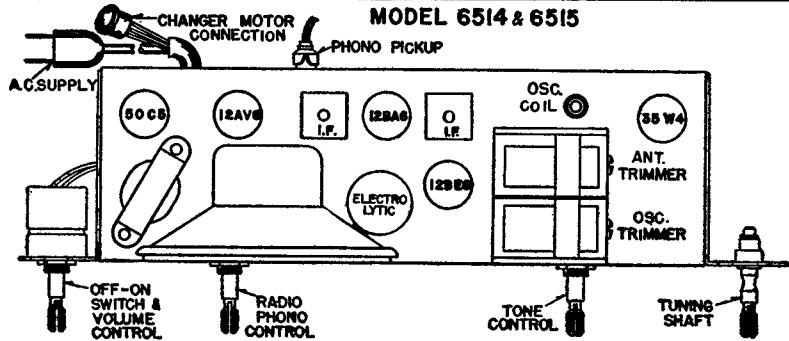

PART NO.	DESCRIPTION	PART NO.	DESCRIPTION	PART NO.	DESCRIPTION
1R-17	R-1 33Ω RESISTOR 1/2W 20%	CC-12	C-1 47 MMFD. CERAMIC CONDENSER	SPK-38	S 4" PM SPEAKER
1R-9	R-2 220Ω RESISTOR 1/2W 20%	CC-13	C-2 220 MMFD. 500V. 20% CER. COND.	VC	VOICE COIL
1R-28	R-3 220MΩ RESISTOR 1/2W 20%	CC-33	C-3 0.05MFD. CONDENSER 400 V.	AT-14	OUTPUT TRANSFORMER
1R-23	R-4 3.3MEG. RESISTOR 1/2W 20%	PC-5	C-4 0.05MFD. CONDENSER 400 V.	LL-39	FERRAMIC ROD ANTENNA
1R-14	R-5 220Ω RESISTOR 1/2W 0%	CC-9	C-5 100MMFD. CERAMIC CONDENSER	L-1	OSC. COIL
VC-78	R-6 1 MEG. VOLUME CONTROL	PC-7	C-6 0.01 MFD. CONDENSER 400V.	L-2	OSC. COIL
1R-13	R-7 2.2MEG. RESISTOR 1/2W 20%	CC-8	C-7 5 MFD. @ 25 W.V.D.C. ELECTROLYTIC	S-1	SWITCH ON VOLUME CHANGER
1R-15	R-8 470MΩ RESISTOR 1/2W 20%	CC-36	C-8 0.003 MFD. 500V. 10% CER. COND.	S-2	SWITCH ON RECORD CHANGER
1R-94	R-9 220Ω RESISTOR 1/2W 20%	CC-38	C-9 50 MFD. .150V.D.C. ELECTROLYTIC	P	PICKUP CARTRIDGE
1R-42	R-10 1000Ω RESISTOR 1W 10%	EO-35	C-10 90 MFD. .150V.D.C. ELECTROLYTIC	M	CHANGER MOTOR
1R-10	R-11 47000Ω RESISTOR 1/2W 20%	PG-21	G-12 .047 MFD. 400V PHENOLIC TUB. COND.	SW-20	RADIO-PHONO SWITCH
1R-12	R-12 1 MEG. RESISTOR 1/2W 20%	CC-16	G-2 TUNING CONDENSER	SW-21	TONE CONTROL SWITCH
L-13	L-1 INPUT I.F. TRANSFORMER				
T-2	T-2 OUTPUT I.F. TRANSFORMER				



UNITED MOTORS

Studebaker

AC-2745
AC-2747

PUSH BUTTON SETUP PROCEDURE

Pull Push Button to the right and out. Tune in desired station manually. Push button all the way in.

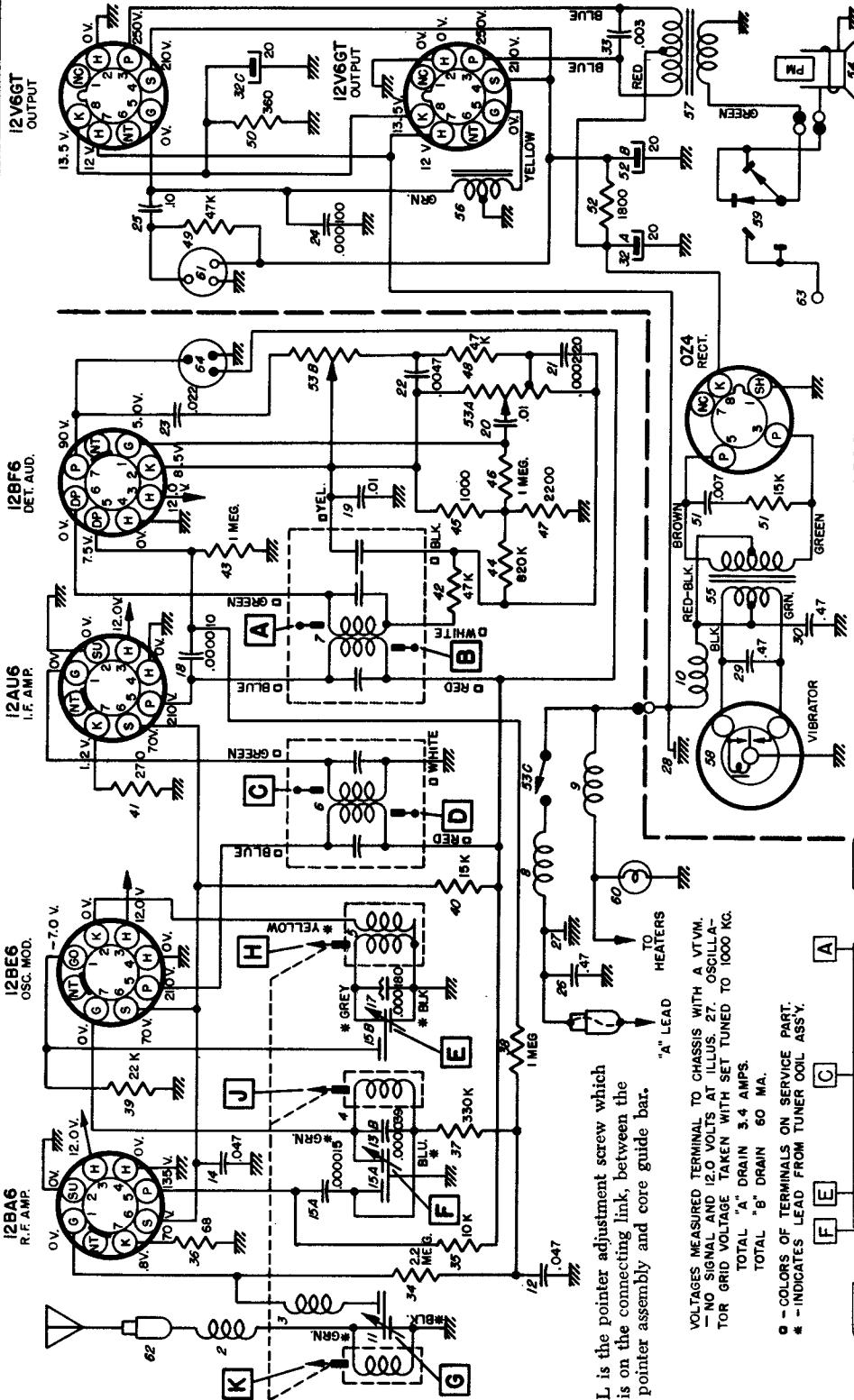

ALIGNMENT PROCEDURE

Steps	Series Capacitor or Dummy Antenna	Connect Signal Generator to	Signal Generator Frequency	Tune Receiver to	Adjust in Sequence For Max. Output
1	0.1 Mfd.	12BE6 Grid (Pin #7)	282 KC	High Frequency Stop	A, B, C, D
2	0.000082 Mfd.	Antenna Connector	1615 KC	High Frequency Stop	*E, F, G
3	0.000082 Mfd.	Antenna Connector	1000 KC	Signal Generator Signal	J, K
4	0.000082 Mfd.	Antenna Connector	1615 KC	High Frequency Stop	F, G
5	0.000082 Mfd.	Antenna Connector	900 KC	Signal Generator Signal	L

*Before making this adjustment check mechanical setting of oscillator core "H." The rear of the core should be 1 1/8" from the mounting end of the coil form. (This measurement is readily made by inserting a suitable plug in the mounting end of the coil form.) Core adjustment should be made with an insulated screw driver.

L is the pointer adjustment screw which is on the connecting link, between the pointer assembly and core guide bar.

VOLTAGES MEASURED TERMINAL TO CHASSIS WITH A VTVM.
— NO SIGNAL AND 12.0 VOLTS AT ILLUS. 27. OSCILLA-TOR GRID VOLTAGE TAKEN WITH SET TUNED TO 1000 KC.
TOTAL "A" DRAIN 3.4 AMPS.
TOTAL "B" DRAIN 60 MA.

□ - COLORS OF TERMINALS ON SERVICE PART.
* - INDICATES LEAD FROM TUNER COIL ASS'Y.

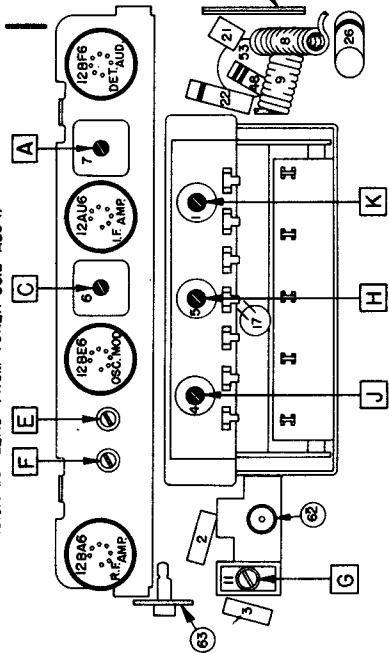

UNITED MOTORS

Studebaker
AC-2746
AC-2748

PARTS LAYOUT — CHASSIS VIEW

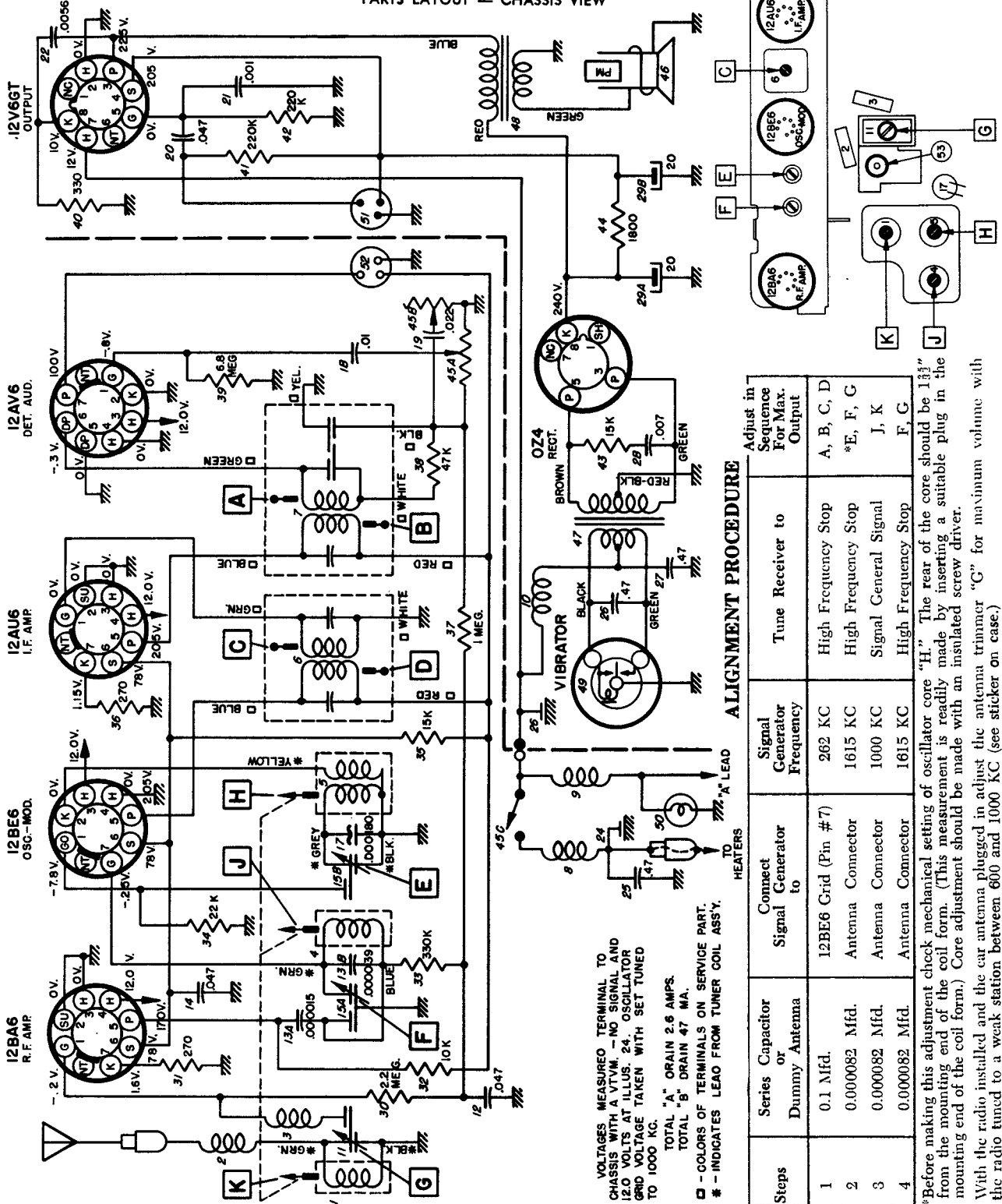

*Before making this adjustment check mechanical setting of oscillator core "H." The rear of the core should be 1 1/3" from the mounting end of the coil form. (This measurement is readily made by inserting a suitable plug in the mounting end of the coil form.) Core adjustment should be made with an insulated screw driver.

With the radio installed and the car antenna plugged in adjust the antenna trimmer "G" for maximum volume with the radio tuned to a weak station between 600 and 1000 KC (see sticker on case.)



UNITED MOTORS

Packard
Clipper 472046

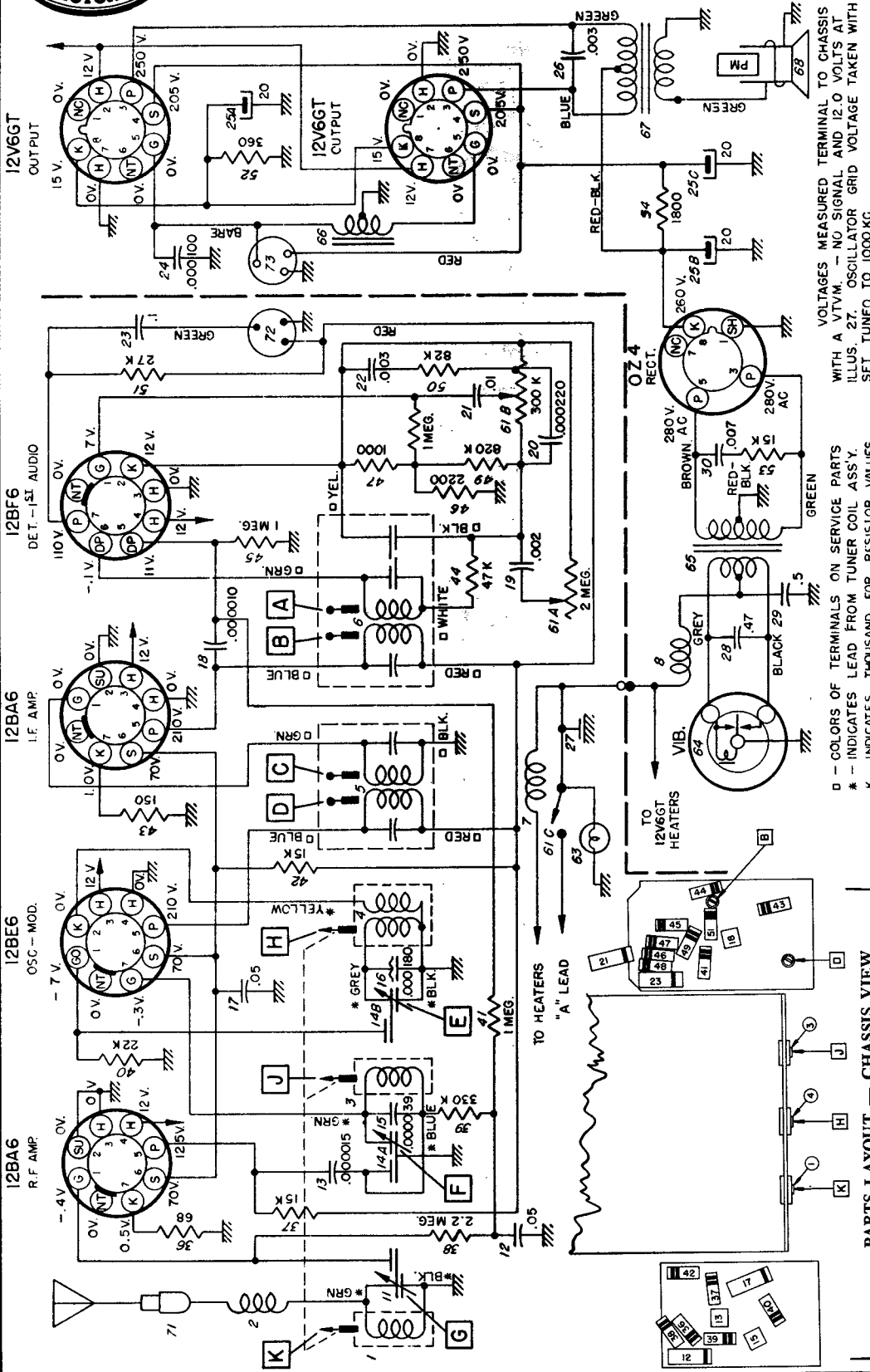

Steps	Series Capacitor or Dummy Antenna	Connect Signal Generator to	Signal Generator Frequency	Tune Receiver to	Adjust in Sequence For Max. Output
1	0.1 Mfd.	12BE6 Grid (Pin #7)	262 KC	High Frequency Stop	A, B, C, D
2	0.000082 Mfd.	Antenna Connector	1615 KC	High Frequency Stop	E, F, G
3	0.000082 Mfd.	Antenna Connector	1000 KC	Signal Generator Signal	J, K
4	0.000082 Mfd.	Antenna Connector	1615 KC	High Frequency Stop	F, G

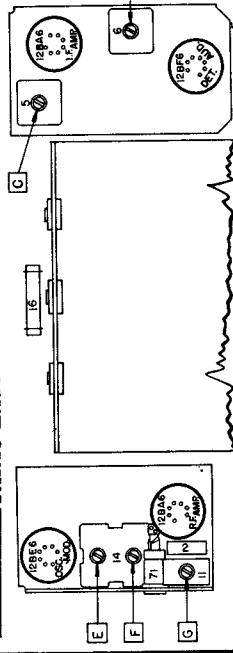

VOLTAGES MEASURED TERMINAL TO CHASSIS WITH A VTVM - NO SIGNAL AND 12.0 VOLTS AT ILLUS. 27. OSCILLATOR GRID VOLTAGE TAKEN WITH SET TUNED TO 1000 KC.

□ - COLORS OF TERMINALS ON SERVICE PARTS WITH A VTVM - NO SIGNAL AND 12.0 VOLTS AT ILLUS. 27. OSCILLATOR GRID VOLTAGE TAKEN WITH SET TUNED TO 1000 KC.

□ - COLORS OF TERMINALS ON SERVICE PARTS WITH A VTVM - NO SIGNAL AND 12.0 VOLTS AT ILLUS. 27. OSCILLATOR GRID VOLTAGE TAKEN WITH SET TUNED TO 1000 KC.

PARTS LAYOUT - TUBE VIEW

UNITED MOTORS

Packard 472047

472048

Packard

6480488
(7266067)

6480489
(7266047)

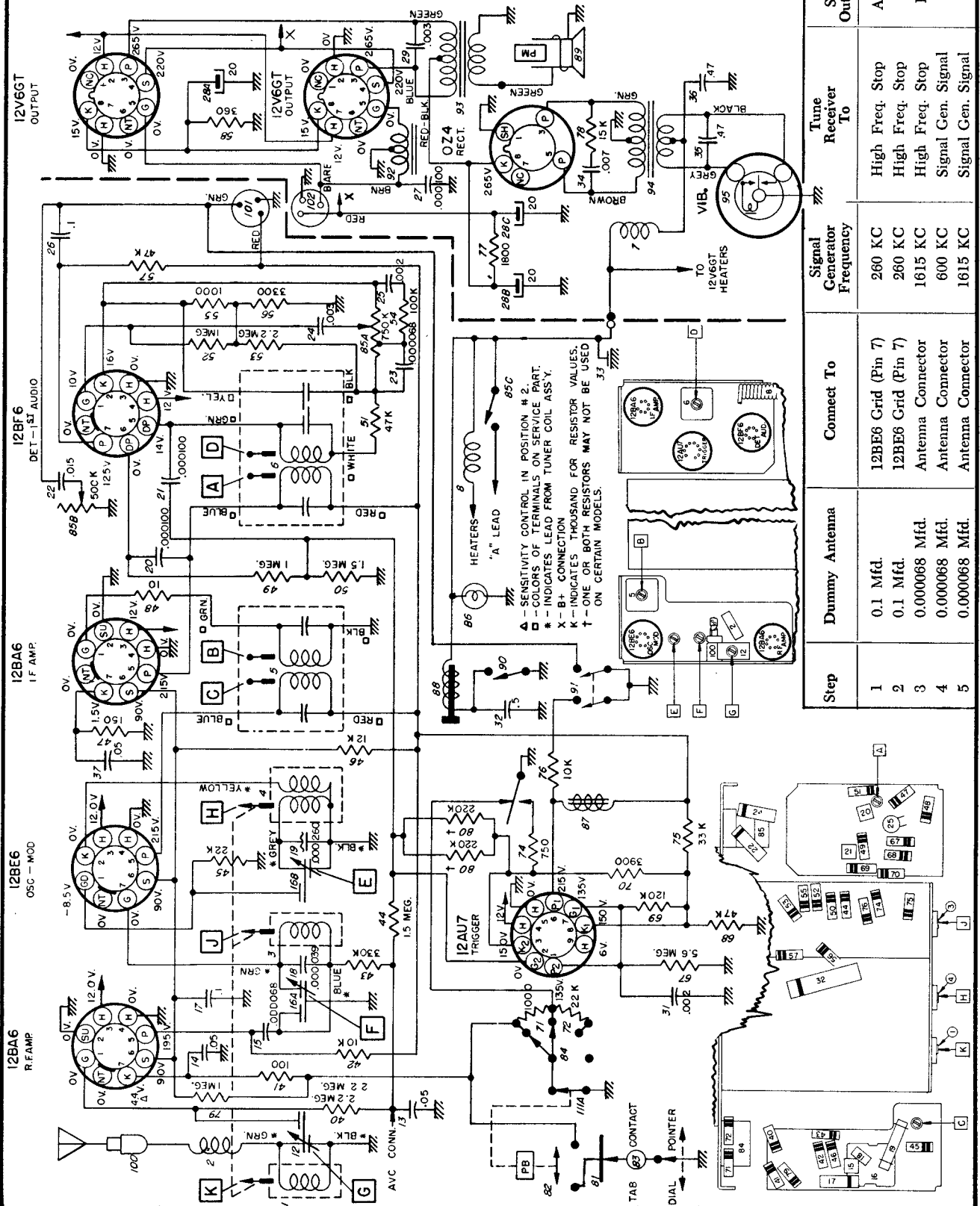

Step	Dummy Antenna	Connect To	Signal Generator Frequency	Tune Receiver To	Adjust in Sequence for Output Indicated
1	0.1 Mfd.	12BE6 Grid (Pin 7)	260 KC	High Freq. Stop	A, C, B Max.
2	0.1 Mfd.	12BE6 Grid (Pin 7)	260 KC	High Freq. Stop	D Min.
3	0.000068 Mfd.	Antenna Connector	1615 KC	High Freq. Stop	E, F, G Max.
4	0.000068 Mfd.	Antenna Connector	600 KC	Signal Gen. Signal	J, K Max.
5	0.000068 Mfd.	Antenna Connector	1615 KC	Signal Gen. Signal	F, G Max.



UNITED MOTORS BUICK MODEL 981707

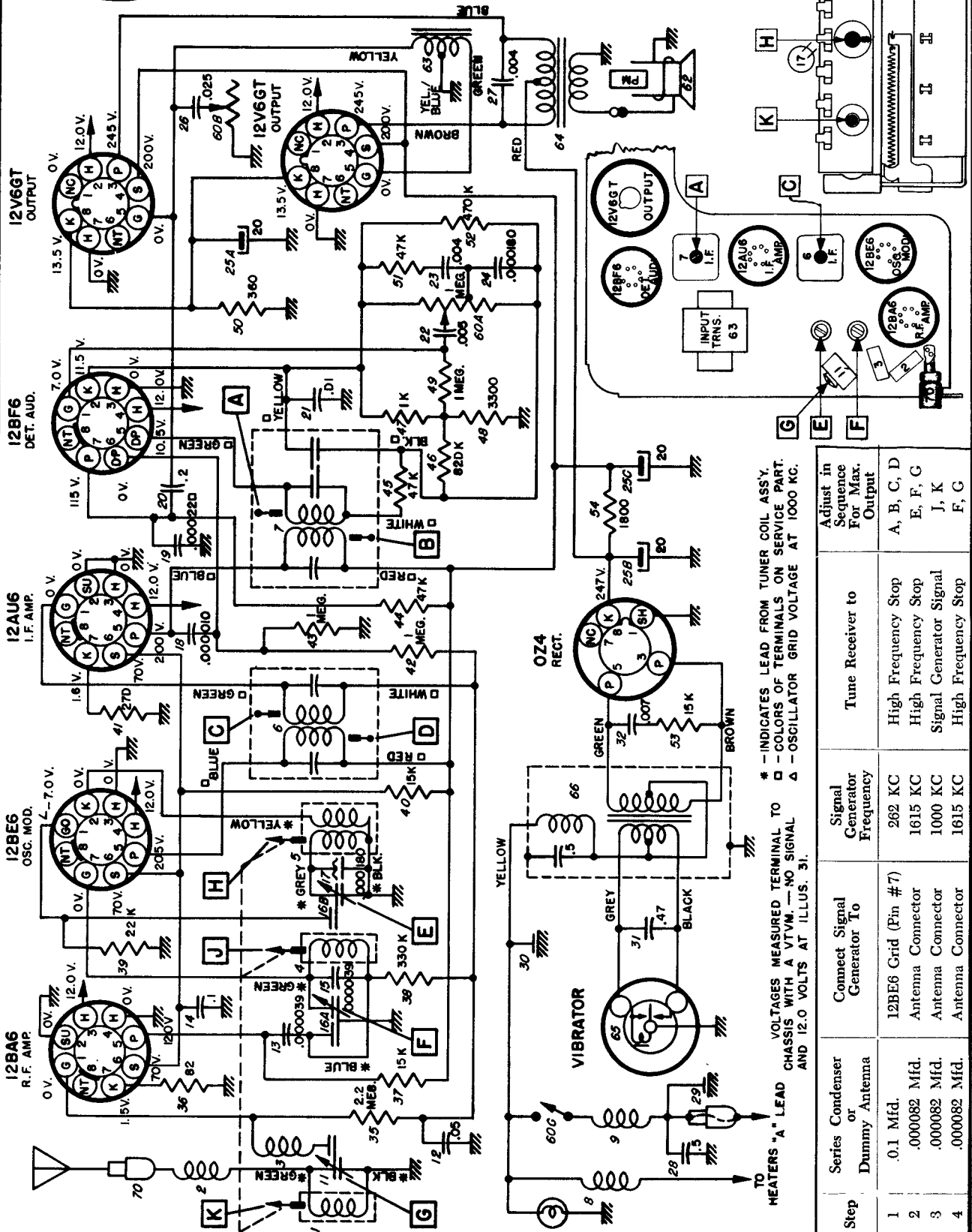

* - INDICATES LEAD FROM TUNER COIL ASS'Y.
 □ - COLORS OF TERMINALS ON SERVICE PART.
 Δ - OSCILLATOR GRID VOLTAGE AT 1000 KC.
 VOLTAGES MEASURED TERMINAL TO CHASSIS WITH A VTVM. - NO SIGNAL AND 12.0 VOLTS AT ILLUS. 31.

Step	Series Condenser or Dummy Antenna	Connect Signal Generator To	Signal Generator Frequency	Tune Receiver to	Adjust in Sequence For Max. Output
1	0.1 Mfd.	12BE6 Grid (Pin #7)	262 KC	High Frequency Stop	A, B, C, D
2	.000082 Mfd.	Antenna Connector	1615 KC	High Frequency Stop	E, F, G
3	.000082 Mfd.	Antenna Connector	1000 KC	Signal Generator Signal	J, K
4	.000082 Mfd.	Antenna Connector	1615 KC	High Frequency Stop	F, G

UNITED MOTORS BUICK MODEL 981708

(Alignment data on the next page adjacent at right.)

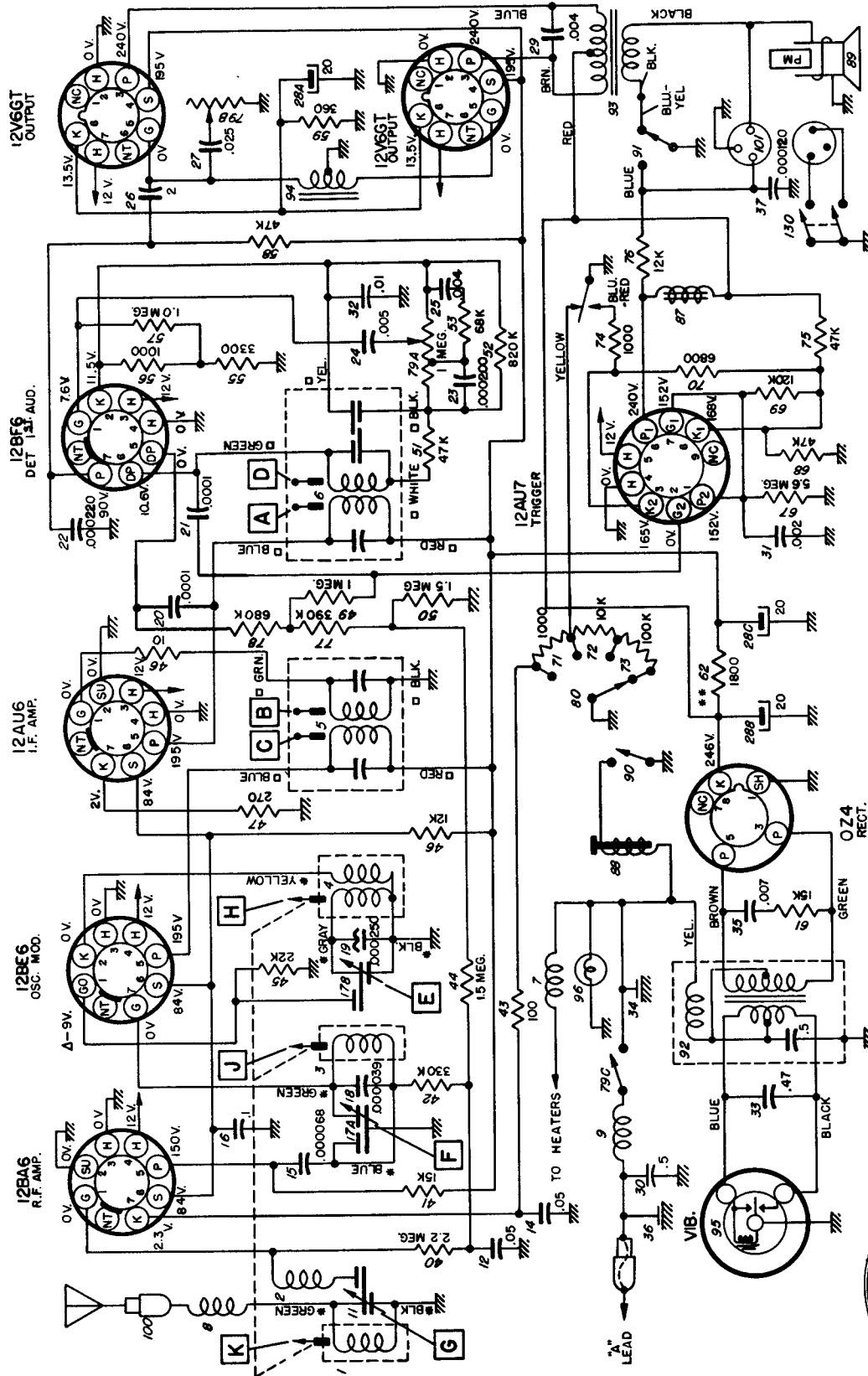

* - INDICATES LEADS FROM TUNER COIL ASS'Y
 □ - COLORS OF TERMINALS ON SERVICE PART
 Δ - OSCILLATOR GRID VOLTAGE AT 1000 KC

ALL VOLTAGES MEASURED FROM SOCKET TERMINALS TO CHASSIS WITH A VACUUM TUBE VOLT METER
 MEASUREMENTS TAKEN WITH NO SIGNAL AND 120 VOLTS AT SPARK PLATE. TUNER NOT SEEKING
 TOTAL "A" DRAIN 3.5 AMPS. TOTAL "B" DRAIN 65 MA TOLERANCE ON VOLTAGES ±10%
 ALL VOLTAGES MEASURED WITH SENSITIVITY CONTROL ONE POSITION FROM MAXIMUM

(Alignment information on the next page adjacent at right.)

BUICK SELECTRONIC MODEL 981708



UNITED MOTORS

BUICK MODEL 981708

ALIGNMENT INFORMATION (Continued from the preceding page at left.)

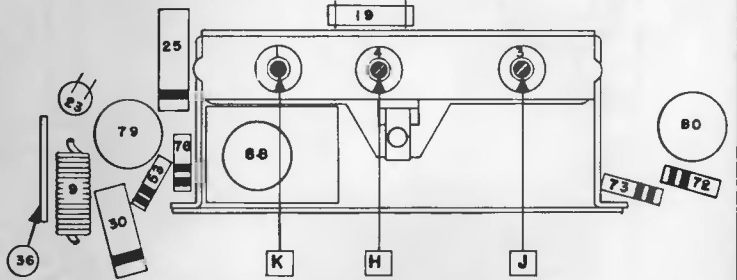
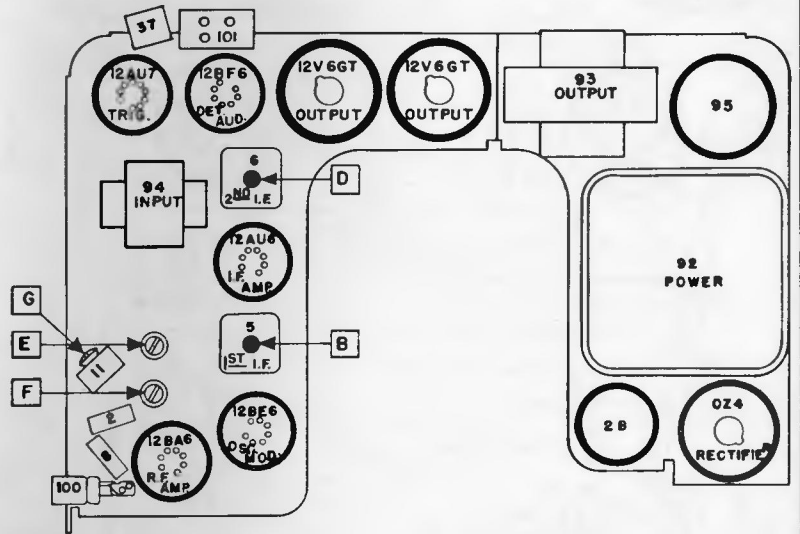
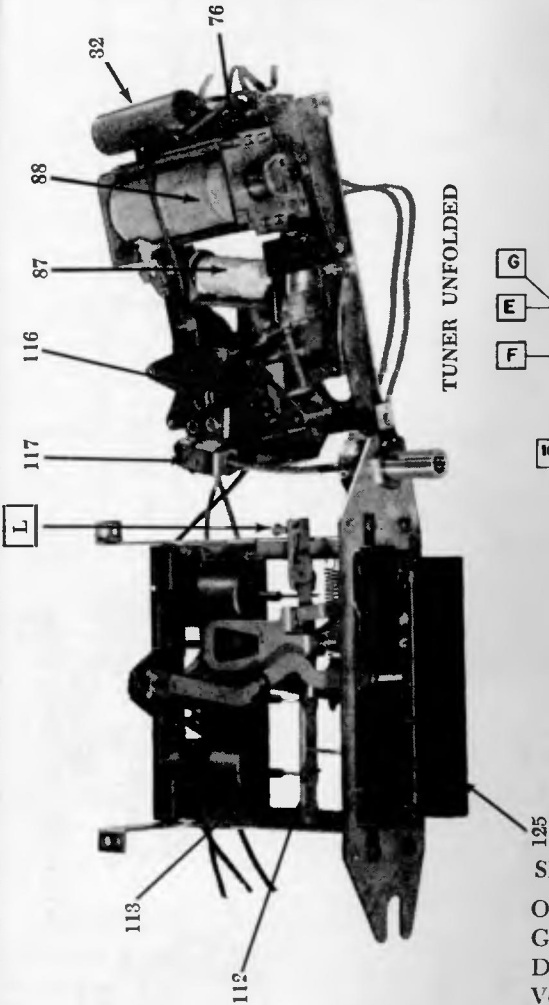

PARTS LAYOUT — TUBE VIEW

SIGNAL SEEKING TUNER ALIGNMENT

- Output Meter Connection VTVM from AVC Line to chassis
- Generator Return Receiver Chassis
- Dummy Antenna In Series With Generator
- Volume Control Maximum Volume
- Tone Control Treble
- Generator Output Not to exceed 2 volts at VTVM

Step	Dummy Antenna	Connect Signal Generator To	Signal Generator Frequency	Tune Receiver To	Adjust in Sequence For Output Indicated
1	0.1 Mfd.	12BE6 Grid (Pin 8)	262 KC	*High Frequency Stop	A, B, C (Max.)
2	0.1 Mfd.	12BE6 Grid (Pin 7)	262 KC	High Frequency Stop	D (Min.)
3	.000082 Mfd.	Antenna Connector	1615 KC	High Frequency Stop	**E, F, G (Max.)
4	.000082 Mfd.	Antenna Connector	600 KC	Signal Generator Signal	J, K (Max.)
5	.000082 Mfd.	Antenna Connector	1615 KC	Signal Generator Signal	F, G (Max.)
6	.000082 Mfd.	Antenna Connector	1000 KC	Signal Generator Signal	***L

*To tune to high frequency, put a 0.070" feeler gauge (or bare #13 wire) in slot against the high frequency stop. Depress station selector bar and allow the planetary arm to run against the feeler gauge. Turn the radio off and then back on.

**Before making this adjustment, check the setting of oscillator core "H." The rear of the core should be 1 3/8" from the mounting end of the coil form. This measurement is readily made by inserting a suitable plug in the mounting end of the coil form. The core adjustment is made from the mounting end of the coil form with an insulated screwdriver. (It will be necessary to steady the core guide bar while making these adjustments. This can be done by applying a downward pressure on the guide bar at the antenna coil end.) If this adjustment is necessary, first dissolve the glyptal seal on the core stud and be sure to re-seal after making the adjustment.

***"L" is the pointer adjustment screw on the end of the core guide bar—adjust so pointer reads 1000 KC. With the radio installed and the antenna plugged in, adjust the antenna trimmer "C" for maximum volume with the radio tuned to a weak station between 600 and 1000 KC (see sticker on case.)



UNITED MOTORS

OLDSMOBILE MODEL 983336
(Continued on next page at right)

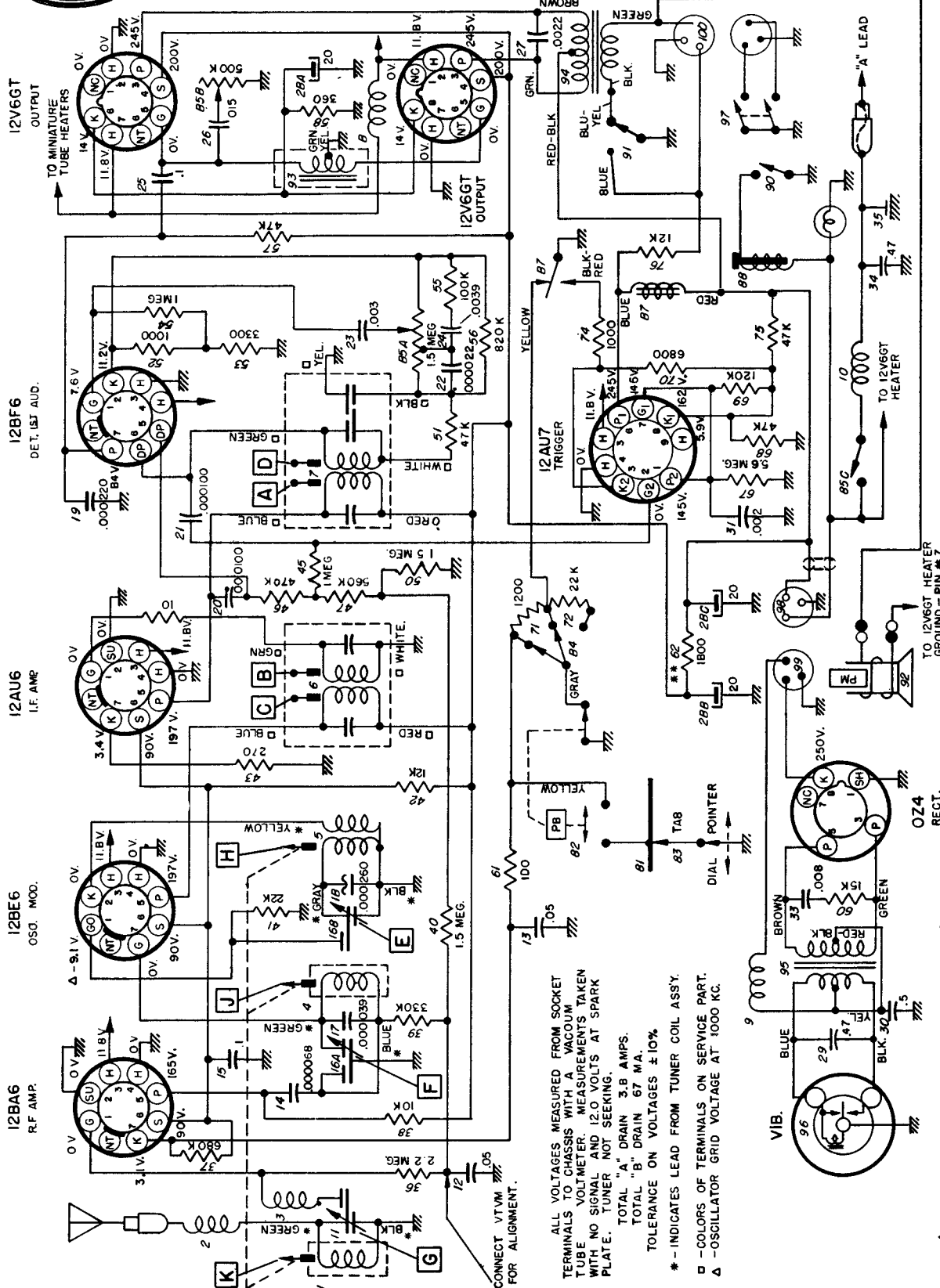

OLDSMOBILE MODEL 983336

ALL VOLTAGES MEASURED FROM SOCKET TERMINALS TO CHASSIS WITH A VACUUM TUBE VOLTMETER. MEASUREMENTS TAKEN WITH NO SIGNAL AND 12.0 VOLTS AT SPARK PLATE. TUNER NOT SEEKING.
TOTAL "A" DRAIN 3.8 AMPS.
TOTAL "B" DRAIN 67 MA.
TOLERANCE ON VOLTAGES ± 10%.
* - INDICATES LEAD FROM TUNER COIL ASS'Y.
□ - COLORS OF TERMINALS ON SERVICE PART.
Δ - OSCILLATOR GRID VOLTAGE AT 1000 KC.

(Alignment information on the next page adjacent at right.)

UNITED MOTORS

Oldsmobile Model 983336

(Continued from preceding page)

SPEAKER—POWER SUPPLY UNIT

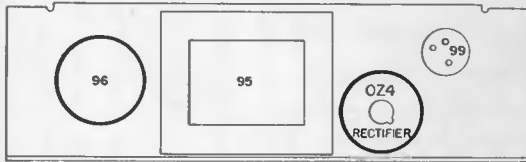

PARTS LAYOUT—TUBE VIEW

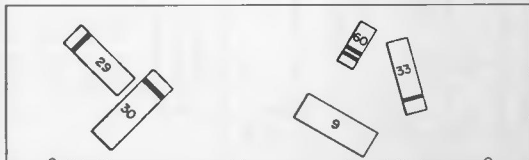

PARTS LAYOUT—CHASSIS VIEW

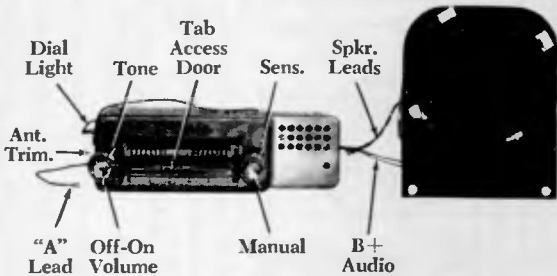

Connect vacuum tube voltmeter between AVC line and ground during alignment.

ALIGNMENT PROCEDURE:

- Generator Return Receiver Chassis
- Dummy Antenna In Series With Generator
- Volume Control Maximum Volume
- Sensitivity Control Position 2. (Position 1 is Maximum)
- Tone Control Treble (max. clockwise)
- Generator Output .. Not to Exceed 2 Volts at VTVM

RF—AUDIO UNIT

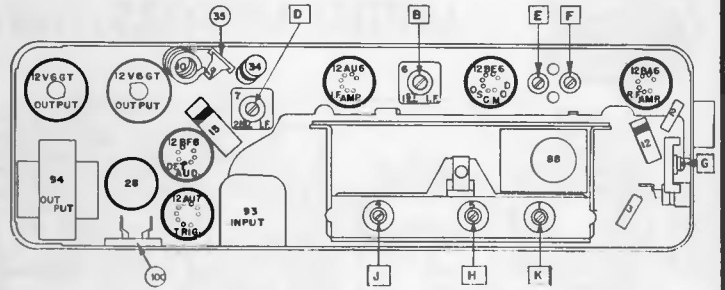

PARTS LAYOUT—TUNER VIEW

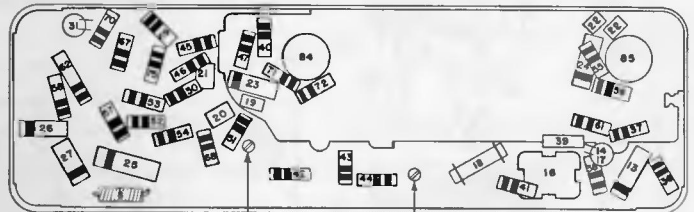

PARTS LAYOUT—CHASSIS VIEW

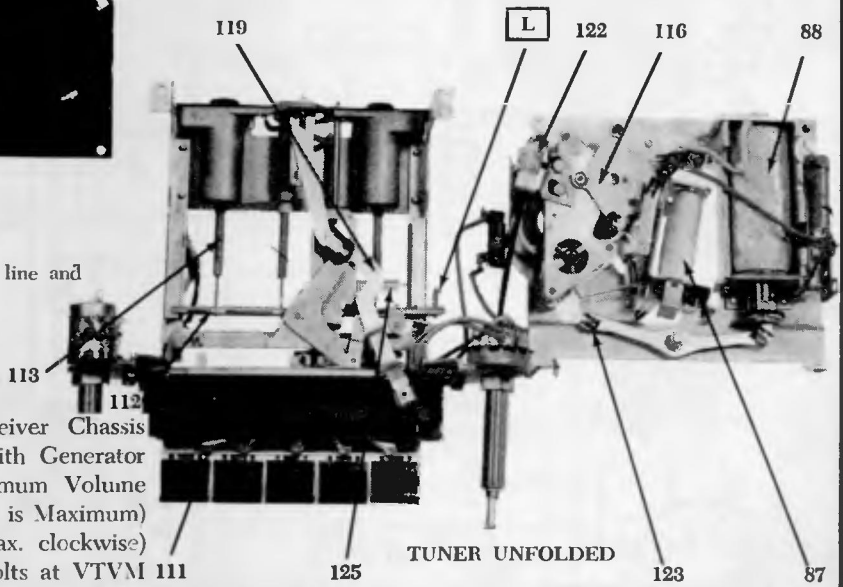

Step	Dummy Antenna	Connect To	Signal Generator Frequency	Tune Receiver To	Adjust in Sequence
1	0.1 mfd.	12BE6 Grid (Pin 7)	262 KC	*High Frequency Stop	A, B, C (Max.)
2	0.1 mfd.	12BE6 Grid (Pin 7)	262 KC	High Frequency Stop	D (Min.)
3	0.000068 mfd.	Antenna Connector	1615 KC	High Frequency Stop	**E, F, G (Max.)
4	0.000068 mfd.	Antenna Connector	600 KC	Signal Generator Signal	J, K (Max.)
5	0.000068 mfd.	Antenna Connector	1615 KC	Signal Generator Signal	F, G (Max.)
6	0.000068 mfd.	Antenna Connector	1000 KC	Signal Generator Signal	***L

*To tune to high frequency, put a 0.070" feeler gauge (or bare #13 wire) in slot against the high frequency stop. (See tuner pictures). Turn manual control to allow the planetary arm to run against the feeler gauge.

**Before making this adjustment, check the setting of oscillator core "H." The rear of the core should be 1 3/8" from the mounting end of the coil form. This measurement is readily made by inserting a suitable plug in the mounting end of the coil form. The core adjustment is made from the mounting end of the coil form with an insulated screw driver. (It will be necessary to steady the core guide bar by applying a downward pressure at the antenna core end of the bar while making these adjustments.) If this adjustment is necessary, first dissolve the glyptal seal on the core stud and be sure to re-seal after making the adjustment.

***"L" is the pointer adjustment screw on the end of the core guide bar—adjust so pointer reads 1000 KC.

With the radio installed and the antenna plugged in, adjust the antenna trimmer "C" for maximum volume with the radio tuned to a weak station between 600 and 1000 KC (see sticker on case).



UNITED MOTORS 1956 Oldsmobile Model 983334

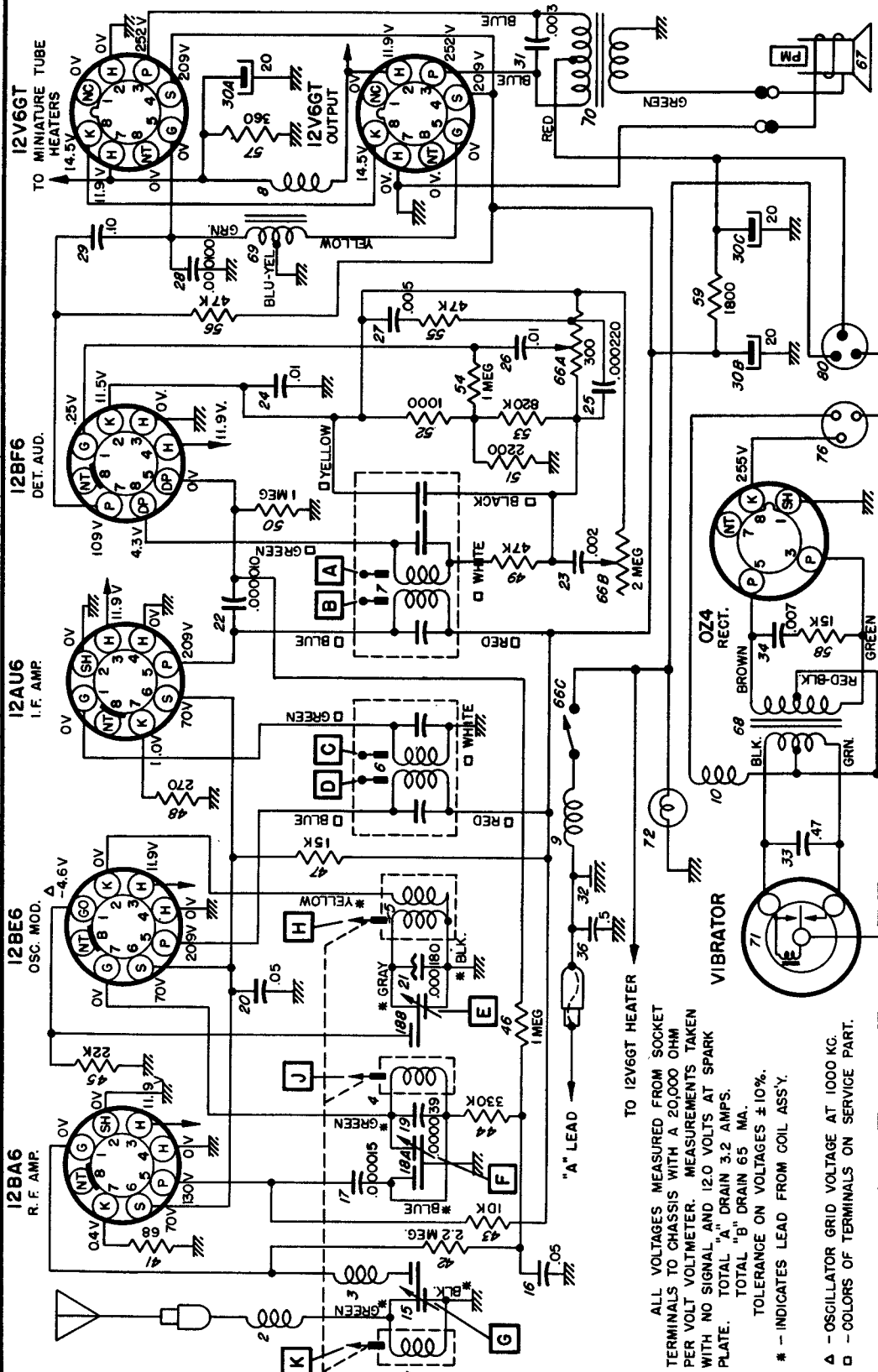

ALL VOLTAGES MEASURED FROM SOCKET TERMINALS TO CHASSIS WITH A 20,000 OHM PER VOLT VOLTMETER. MEASUREMENTS TAKEN WITH NO SIGNAL AND 12.0 VOLTS AT SPARK PLATE. TOTAL "A" DRAIN 3.2 AMPS. TOTAL "B" DRAIN 65 MA. TOLERANCE ON VOLTAGES ±10%. * - INDICATES LEAD FROM COIL ASS'Y.

Δ - OSCILLATOR GRID VOLTAGE AT 1000 KC.
 □ - COLORS OF TERMINALS ON SERVICE PART.

Step	Series Condenser or Dummy Antenna	Connect to	Signal Generator Frequency	Tune Receiver to	Adjust in Sequence For Max. Output
1	0.1 Mfd.	12BE6 Grid (Pin # 7)	262 KC	High Frequency Stop	A, B, C, D
2	0.000068 Mfd.	Antenna Connector	1615 KC	High Frequency Stop	E, F, G
3	0.000068 Mfd.	Antenna Connector	1000 KC	Signal Generator Signal	I, K
4	0.000068 Mfd.	Antenna Connector	1615 KC	High Frequency Stop	F, G

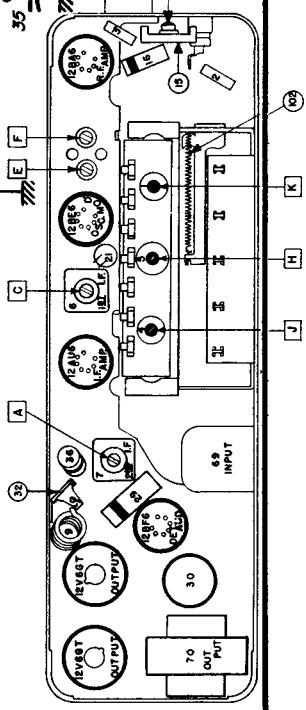



UNITED MOTORS

Chevrolet 987086 and 987364

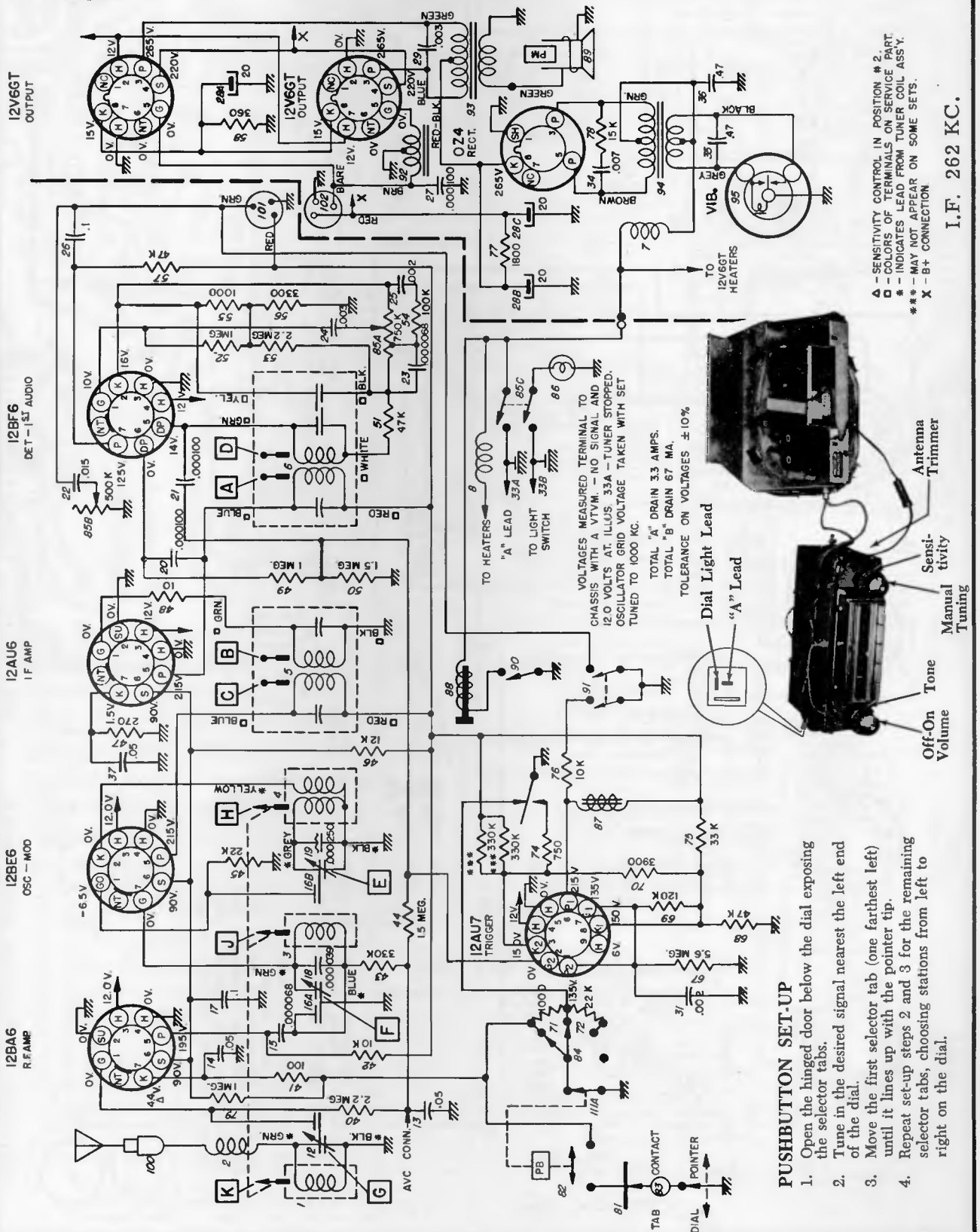

PUSHBUTTON SET-UP

1. Open the hinged door below the dial exposing the selector tabs.
2. Tune in the desired signal nearest the left end of the dial.
3. Move the first selector tab (one farthest left) until it lines up with the pointer tip.
4. Repeat set-up steps 2 and 3 for the remaining selector tabs, choosing stations from left to right on the dial.



▲ - SENSITIVITY CONTROL IN POSITION # 2.
 □ - COLORS OF TERMINALS ON SERVICE PART.
 * - INDICATES LEAD FROM TUNER COIL ASSY.
 *** - MAY NOT APPEAR ON SOME SETS.
 X - B+ CONNECTION

I.F. 262 KC.

UNITED MOTORS

(Continued on next page)

Chevrolet 987368

Packard 7266027
Clipper (480487)

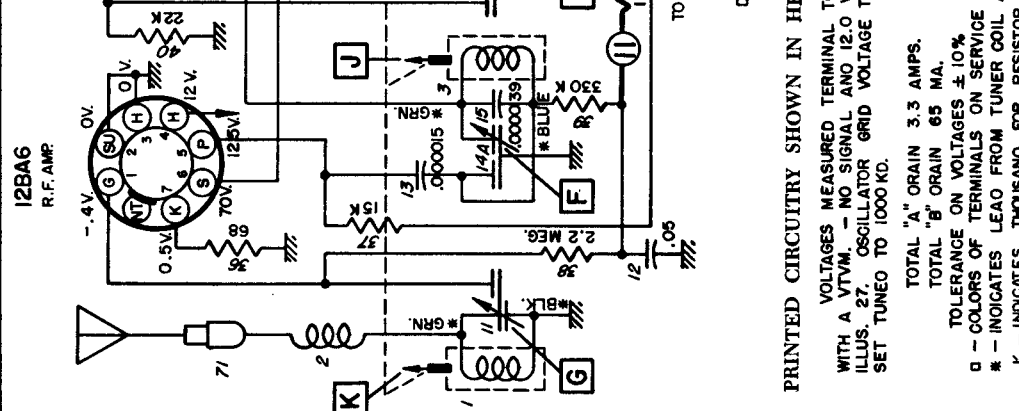
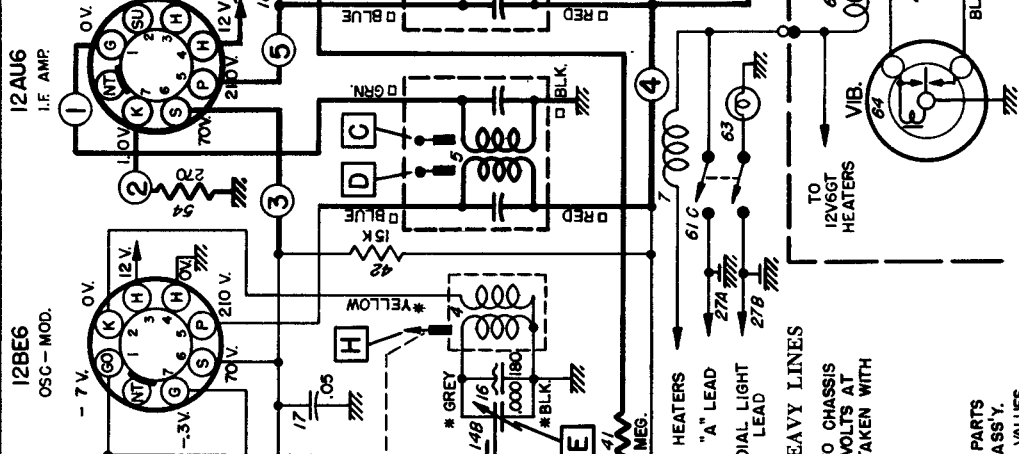
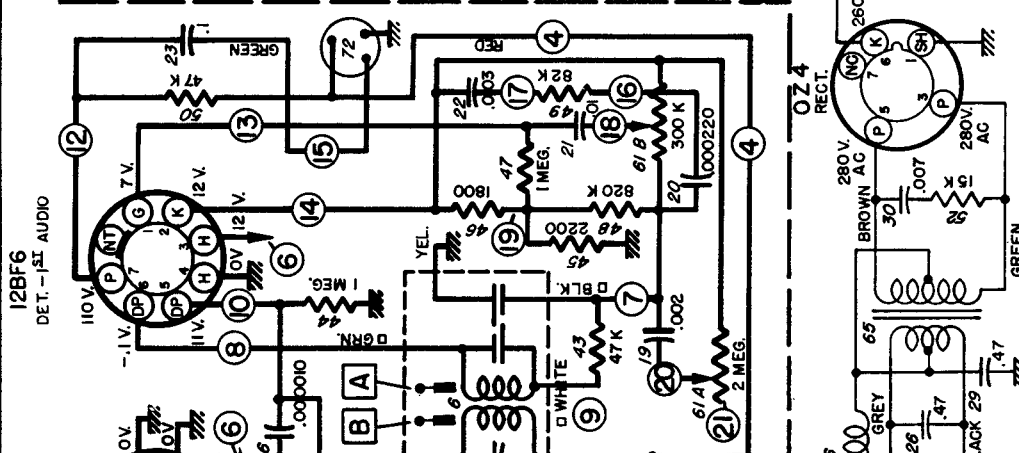
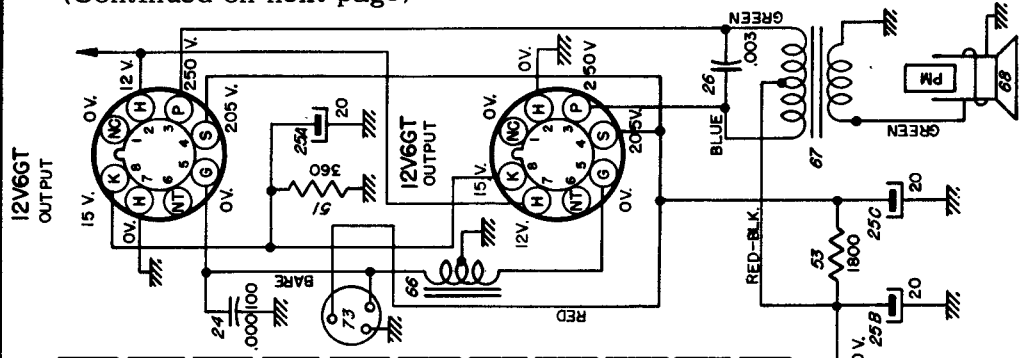

See next page adjacent at right for alignment and other service information.

PUSH BUTTON SETUP PROCEDURE
Pull Push Button to the right and out. Tune in desired station manually. Push button all the way in.

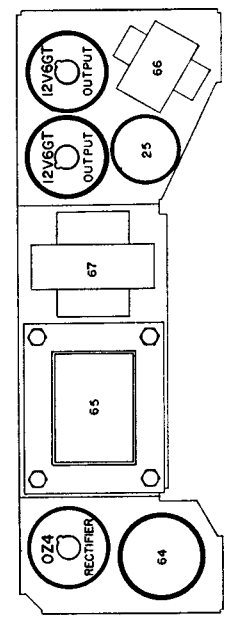
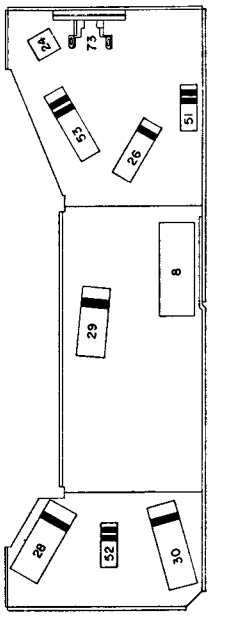

PARTS LAYOUT — CHASSIS VIEW (POWER SUPPLY)

PARTS LAYOUT — TUBE VIEW (POWER SUPPLY)

PRINTED CIRCUITRY SHOWN IN HEAVY LINES

VOLTAGES MEASURED TERMINAL TO CHASSIS WITH A VTVM. — NO SIGNAL AND 12.0 VOLTS AT ILLUS. 27. OSCILLATOR GRID VOLTAGE TAKEN WITH SET TUNED TO 1000 KC.

TOTAL "A" ORAIN 3.3 AMPS.
TOTAL "B" ORAIN 65 MA.
TOLERANCE ON VOLTAGES ±10%
□ — COLORS OF TERMINALS ON SERVICE PARTS
* — INDICATES LEAD FROM TUNER COIL ASS'Y.
K. — INDICATES THOUSAND FOR RESISTOR VALUES.

PRINTED CIRCUIT
(Bottom View)

UNITED MOTORS
(Continued)

Chevrolet 987368
Packard 7266027

PARTS LAYOUT
(Top View)

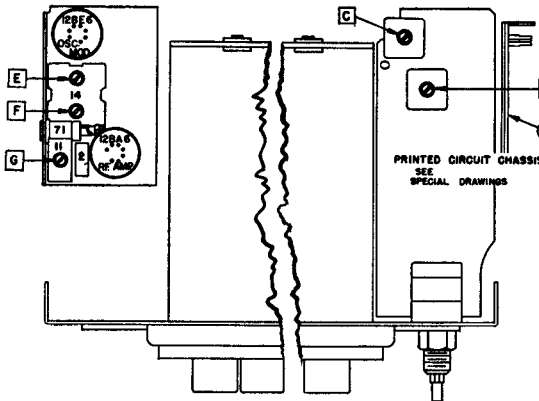
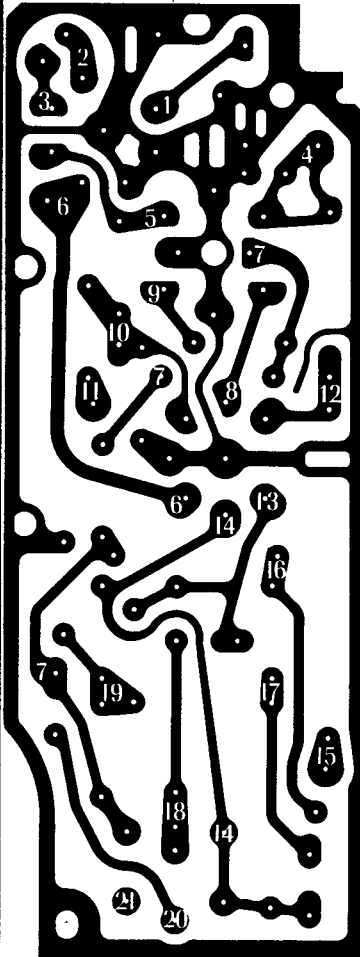

PARTS LAYOUT — TUBE VIEW

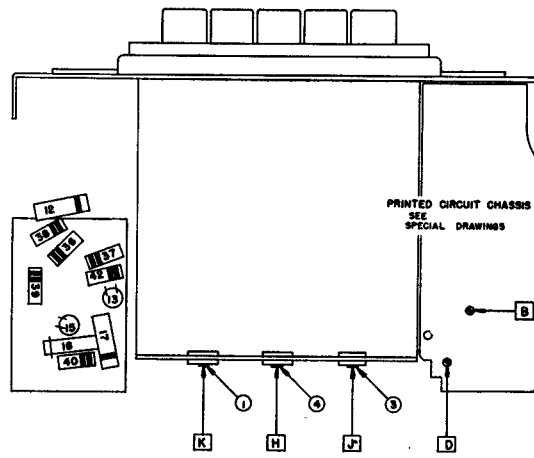

PARTS LAYOUT — CHASSIS VIEW

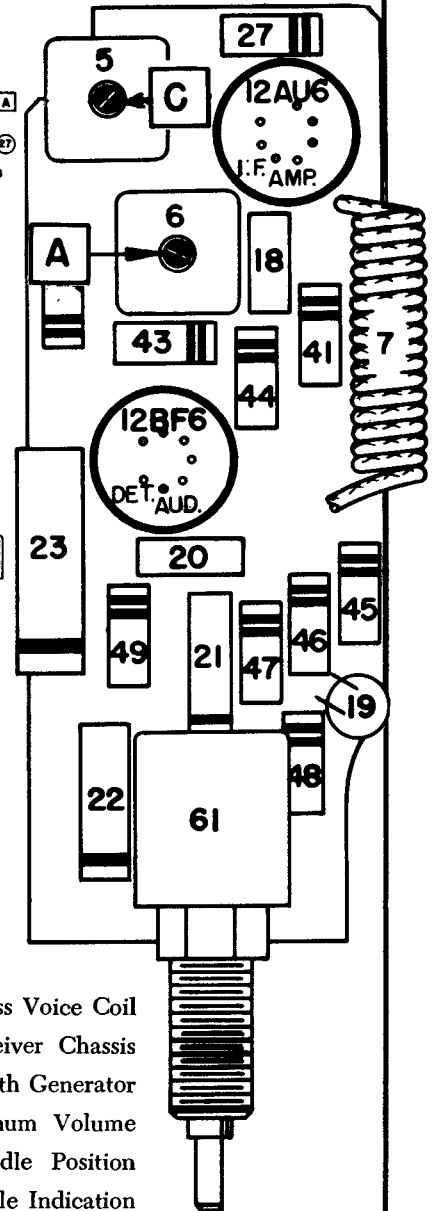

ALIGNMENT PROCEDURE

- Output Meter Connections Across Voice Coil
- Generator Return To Receiver Chassis
- Dummy Antenna In Series With Generator
- Volume Control Position Maximum Volume
- Tone Control Position Middle Position
- Generator Output Minimum for Readable Indication

Steps	Series Capacitor or Dummy Antenna	Connect Signal Generator to	Signal Generator Frequency	Tune Receiver to	Adjust in Sequence For Max. Output
1	0.1 Mfd.	12BE6 Grid (Pin #7)	262 KC	High Frequency Stop	A, B, C, D
2	0.000082 Mfd.	Antenna Connector	1615 KC	High Frequency Stop	*E, F, G
3	0.000082 Mfd.	Antenna Connector	1000 KC	Signal Generator Signal	J, K
4	0.000082 Mfd.	Antenna Connector	1615 KC	High Frequency Stop	F, G
5	0.000082 Mfd.	Antenna Connector	900 KC	Signal Generator Signal	L**

*Before making this adjustment check mechanical setting of oscillator core "H." The rear of the core should be $1\frac{3}{8}$ " from the mounting end of the coil form. (This measurement is readily made by inserting a suitable plug in the mounting end of the coil form.) Core adjustment should be made with an insulated screw driver.

**L is the pointer adjustment screw which is on the connecting link, between the pointer assembly and core guide bar. It should be adjusted so that when looking directly at the dial the pointer is on the 900 KC mark. This setting is to give the correct relationship between the pointer and the dial when the radio is installed in a car. With the radio installed and the car antenna plugged in adjust the antenna trimmer "G" for maximum volume with the radio tuned to a weak station between 600 and 1000 KC (see sticker on case.)

UNITED MOTORS

12V PONTIAC MODEL 988569

(Alignment information on the next page adjacent at right.)

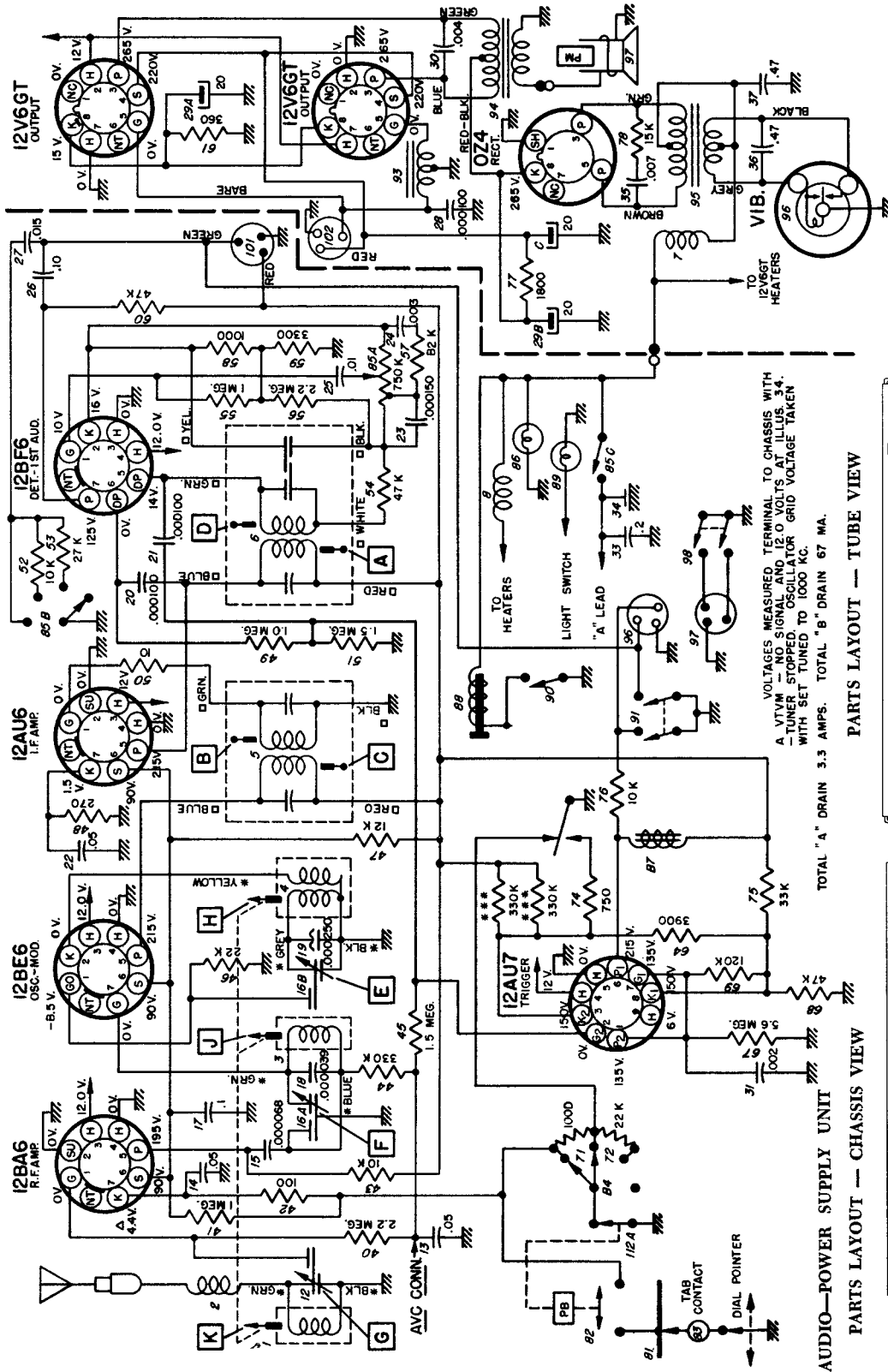

VOLTAGES MEASURED TERMINAL TO CHASSIS WITH A VTVM SIGNAL AND 20 OHMS AT ALLUS. 4.4. TUNER STOPPED. OSC. TOR. GRID VOLTAGE TAKEN WITH SET TUNED TO 1000 KC.

TOTAL "A" DRAIN 3.3 AMPS. TOTAL "B" DRAIN 67 MA.

PARTS LAYOUT -- TUBE VIEW

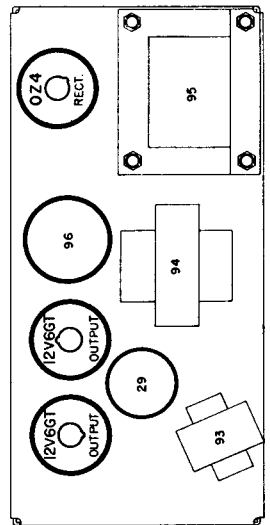

PARTS LAYOUT -- CHASSIS VIEW

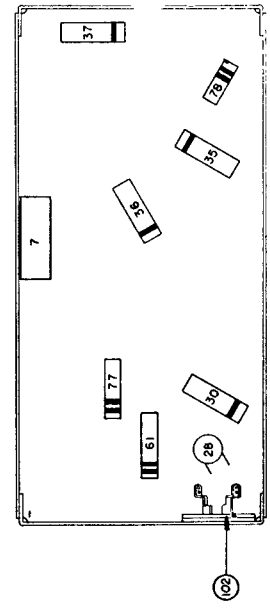

- ▲ - SENSITIVITY CONTROL IN POSITION # 2
- - COLORS OF TERMINALS ON SERVICE PART.
- - INDICATES LEAD FROM TUNER COIL ASS'Y.
- *** - EITHER OR BOTH RESISTORS MAY NOT BE FOUND ON ALL SETS.



UNITED MOTORS PONTIAC 988569, Alignment Information (Continued)
(See preceding page at left for circuit diagram)

RF—UNIT

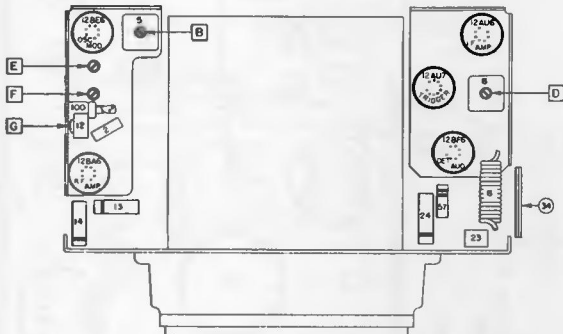

PARTS LAYOUT — TUBE VIEW

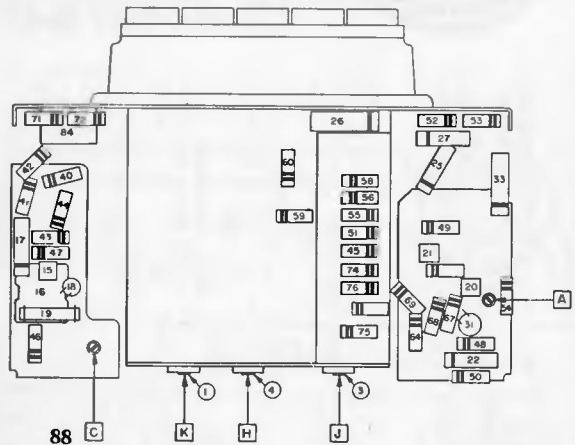

PARTS LAYOUT — CHASSIS VIEW

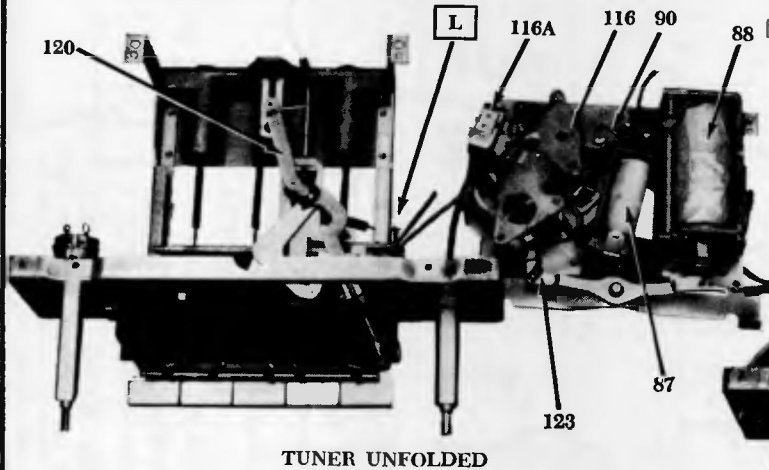

TUNER UNFOLDED

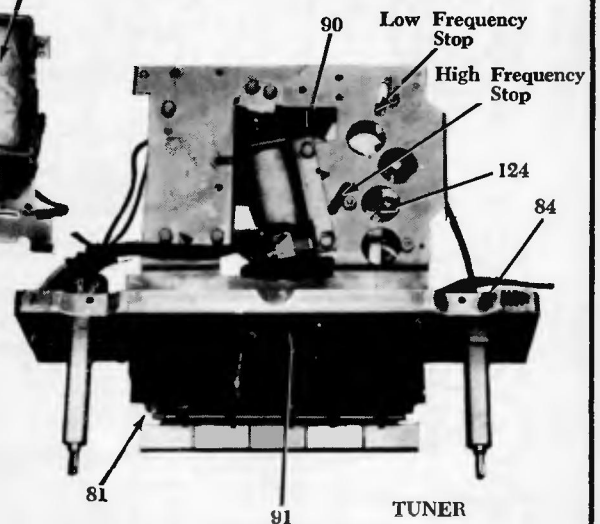

TUNER

SIGNAL SEEKING TUNER ALIGNMENT PROCEDURE:

Connect vacuum tube voltmeter between AVC line and ground during alignment.

- Generator Return Receiver Chassis
- Dummy Antenna In Series With Generator
- Volume Control Maximum Volume
- Sensitivity Control Position 2. (Position 1 is Maximum)
- Generator Output Not to Exceed 2 Volts at VTVM

Step	Dummy Antenna	Connect To	Signal Generator Frequency	Tune Receiver To	Adjust in Sequence
1	0.1 Mfd.	12BE6 Grid (Pin 7)	262 KC	*High Frequency Stop	A, B, C (Max.)
2	0.1 Mfd.	12BE6 Grid (Pin 7)	262 KC	High Frequency Stop	D (Min.)
3	.000068 Mfd.	Antenna Connector	1615 KC	High Frequency Stop	**E, F, G (Max.)
4	.000068 Mfd.	Antenna Connector	600 KC	Signal Generator Signal	J, K (Max.)
5	.000068 Mfd.	Antenna Connector	1615 KC	Signal Generator Signal	F, G (Max.)
6	.000068 Mfd.	Antenna Connector	1000 KC	Signal Generator Signal	***L

*To tune to high frequency, put a 0.070" feeler gauge (or bare #13 wire) in slot against the high frequency stop. (See tuner pictures). Turn manual control to allow the planetary arm to run against the feeler gauge.

**Before making this adjustment, check the setting of oscillator core "H." The rear of the core should be 1 3/8" from the mounting end of the coil form. This measurement is readily made by inserting a suitable plug in the mounting end of the coil form. The core adjustment is made from the mounting end of the coil form with an insulated screw driver. (It will be necessary to steady the core guide bar by applying a downward pressure at the antenna core end of the bar while making these adjustments.) If this adjustment is necessary, first dissolve the glyptal seal on the core stud and be sure to re-seal after making the adjustment.

***"L" is the pointer adjustment screw on the end of the core guide bar—adjust so pointer reads 1000 KC.

With the radio installed and the antenna plugged in, adjust the antenna trimmer "C" for maximum volume with the radio tuned to a weak station between 600 and 1000 KC (see sticker on case).



UNITED MOTORS

Chevrolet Truck Model 987187

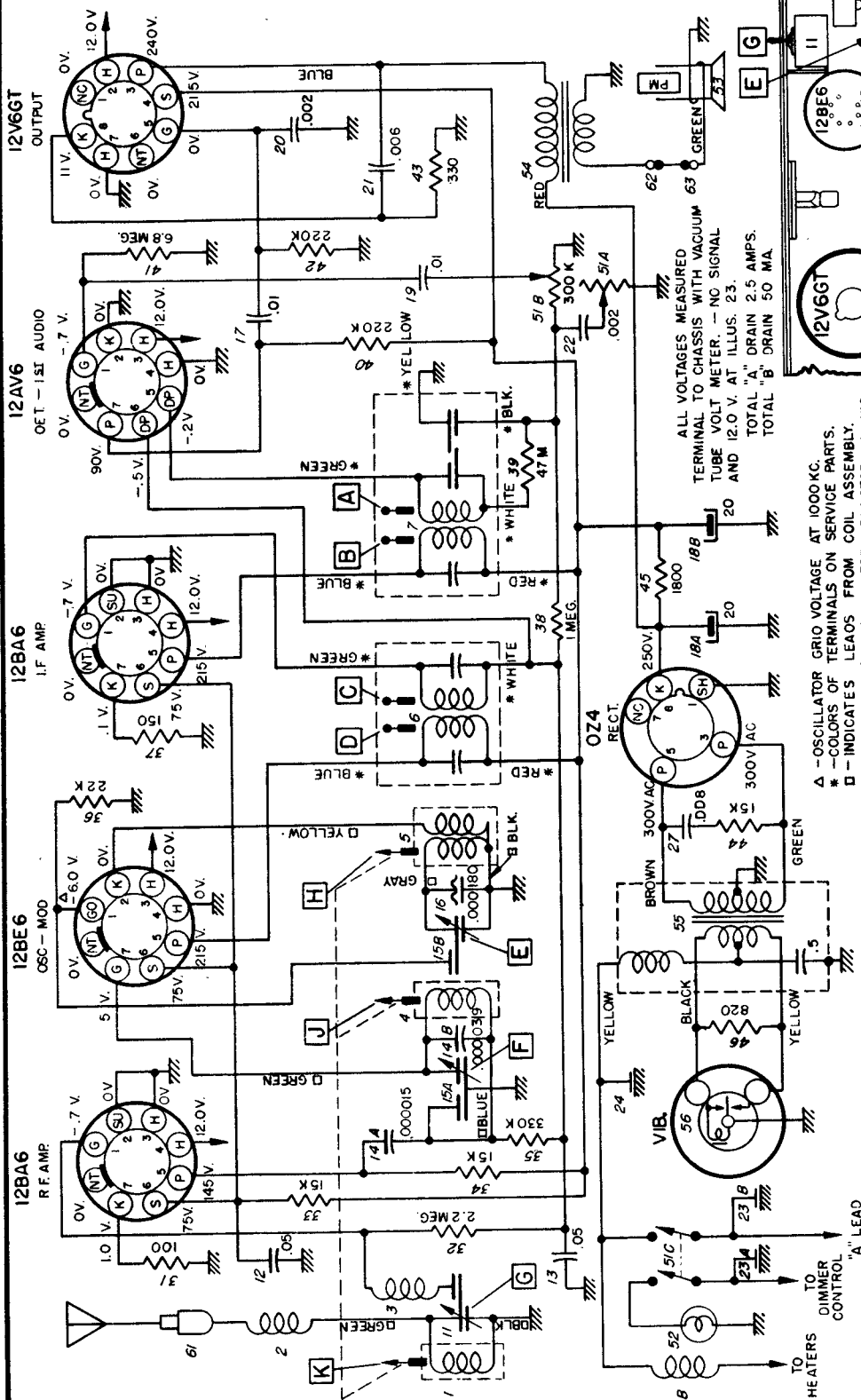

ALL VOLTAGES MEASURED
TERMINAL TO CHASSIS WITH VACUUM
TUBE VOLT METER, - NC SIGNAL
TOTAL "A" DRAIN 2.5 AMPS.
TOTAL "B" DRAIN 50 MA

△ - OSCILLATOR GRID VOLTAGE AT 1000 KC.
* - COLORS OF TERMINALS ON SERVICE PARTS.
□ - INDICATES LEADS FROM COIL ASSEMBLY.
K - INDICATES THOUSAND FOR RESISTOR VALUES.

ALIGNMENT PROCEDURE

Steps	Series Capacitor or Dummy Antenna	Connect Signal Generator to	Signal Generator Frequency	Tune Receiver to	Adjust in Sequence For Max. Output
1	0.1 Mfd.	12BE6 Grid (Pin #7)	262 KC	High Frequency Stop	A, B, C, D
2	0.000082 Mfd.	Antenna Connector	1615 KC	High Frequency Stop	*E, F, G
3	0.000082 Mfd.	Antenna Connector	1000 KC	Signal General Signal	J, K
4	0.000082 Mfd.	Antenna Connector	1615 KC	High Frequency Stop	F, G

*Before making this adjustment check mechanical setting of oscillator core "H". The rear of the core should be 183° from the mounting end of the coil form. (This measurement is readily made by inserting a suitable plug in the mounting end of the coil form.) Core adjustment should be made with an insulated screw driver.

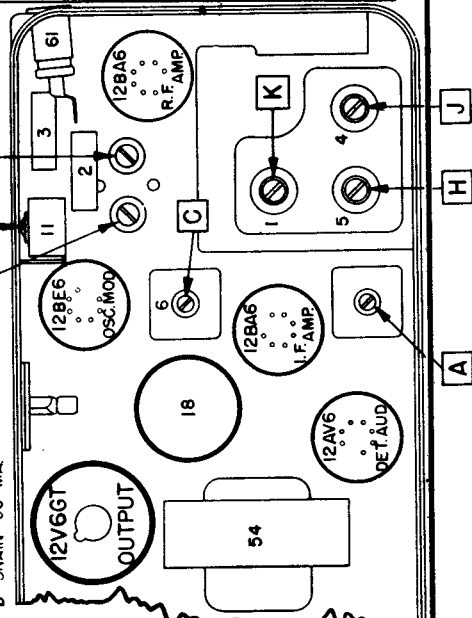

Western Auto Supply Company

MODEL NOS. D2552A, D2553A

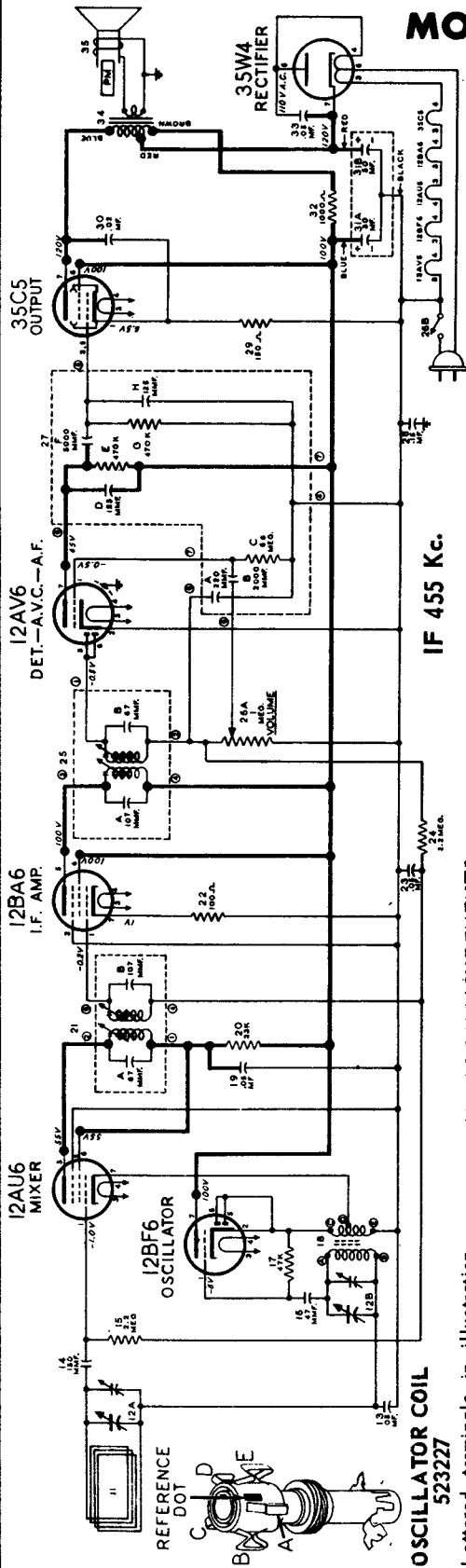

OSCILLATOR COIL
523227

Lettered terminals in illustration correspond to similarly lettered terminals on the circuit diagram.

VOLTAGE MEASUREMENTS

All voltages measured to B- using a 20,000 ohm per volt meter with the receiver connected to a 117 volt 60 cycle power supply.

Loop terminals shorted together. No voltage reading at a tube element indicated zero voltage or voltage which cannot be accurately measured with a 20,000 ohm per volt meter.

IF 455 Kc.

ALIGNMENT PROCEDURE

1. Remove chassis and loop antenna, as a unit, from cabinet as follows:
 - a. DO NOT ATTEMPT TO REMOVE POINTER FROM THE FRONT OF CABINET.
 - b. Pull Tuning and Volume knobs straight off their respective shafts.
 - c. Pry off the two retaining clips at top of cabinet back, and remove the two chassis mounting screws at inside rear corner of cabinet. (NOTE: Do not disturb the two externally mounted screws at bottom of cabinet back. These screws serve to mount loop and back to chassis frame.)
 - d. Chassis with loop antenna can now be withdrawn from cabinet. It will be noted that while doing this, that, the cabinet grille will retain the pointer, thus, allowing it to be pulled from its shaft.
2. Connect an output meter across the speaker voice coil or from the plate of the 50C5 tube to B- through a 0.1 Mfd. condenser.
3. For I.F. Alignment, connect ground lead of signal generator to a B- terminal. CAUTION: If your signal generator is designed with an AC-DC power supply, connect ground lead to a B- terminal through a 0.25 Mfd. condenser.
4. For Oscillator and Antenna alignment, signal from the generator will have to be injected by the use of a coupling loop. This loop can be formed by winding several turns of wire in a circular shape and placing this coupling loop adjacent and parallel to receiver's loop antenna.
5. Set volume control at maximum and use a weak signal from the signal generator.
6. Before re-assembling chassis to cabinet, be sure that tuning control and gang condenser has been turned fully counter-clockwise (gang fully meshed).

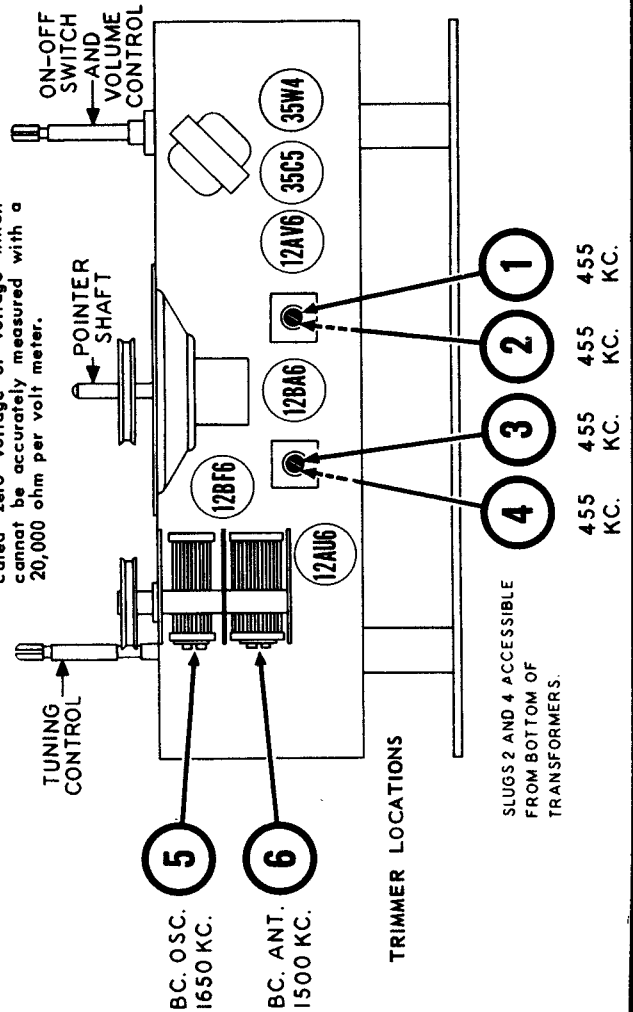

SLUGS 2 AND 4 ACCESSIBLE FROM BOTTOM OF TRANSFORMERS.

Western Auto Supply Company

MODEL NO. D3500A

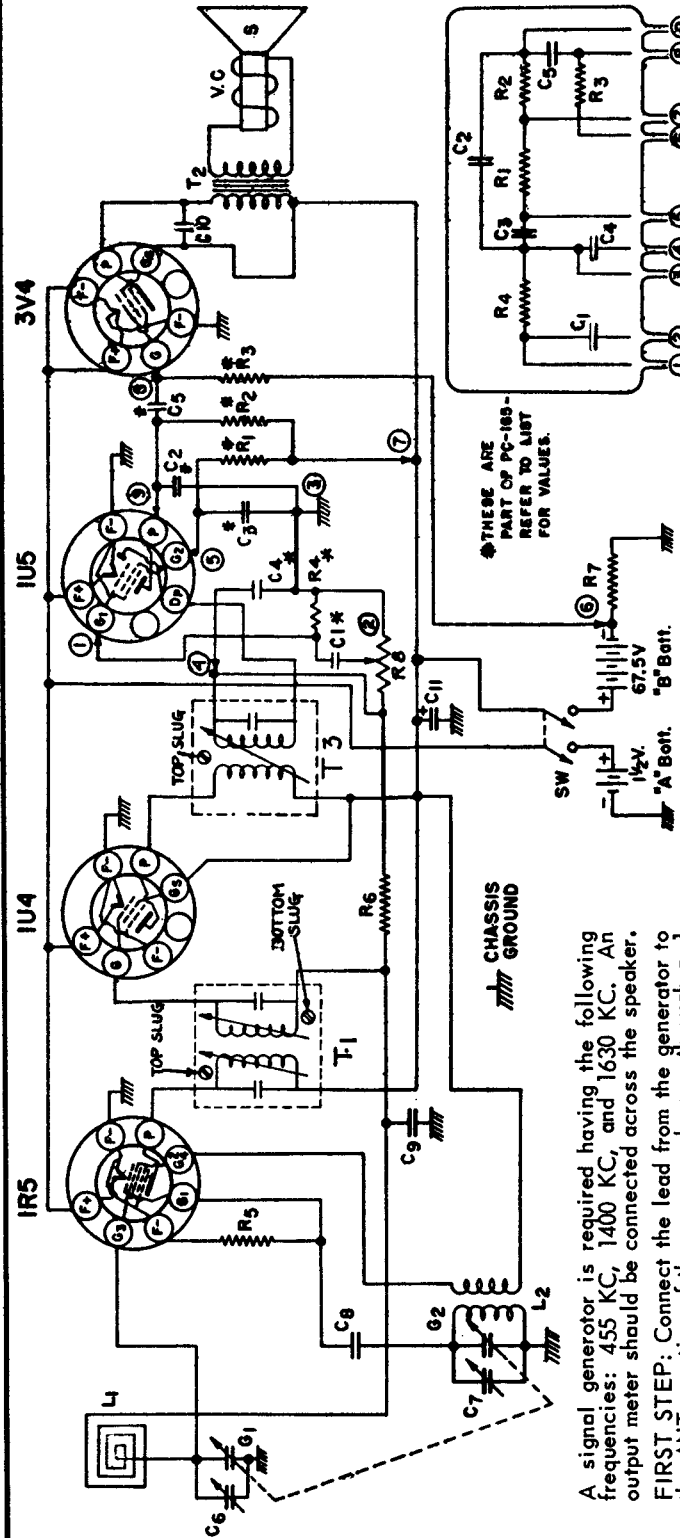

THIRD STEP: Remove the generator leads from the gang condenser and the chassis. Loosely couple the generator to the antenna by laying the hot generator lead near the antenna rod. Set the generator at 1400 KC. and tune in the 1400 KC. signal on the receiver. Adjust the ANT. trimmer until a maximum signal is noted on the output meter.

A signal generator is required having the following frequencies: 455 KC, 1400 KC, and 1630 KC. An output meter should be connected across the speaker.

FIRST STEP: Connect the lead from the generator to the ANT. section of the gang condenser, through a .1 Mfd. condenser. The ground lead from the generator may be connected to any spot on the metal chassis. Turn the gang condenser to complete minimum capacity. Set the generator to 455 KC. Adjust the movable iron cores in the IF cans. The IF adjustments are made in the top and in the bottom of the can nearest to the gang condenser. The remaining IF can, farthest from the gang condenser, is adjusted only from the top. Adjust the cores until a maximum reading is noted on the output meter.

The volume control of the receiver should be turned to maximum during the IF and all subsequent alignment and the generator output as low as possible to prevent the AVC from working and giving false readings.

SECOND STEP: With the leads from the generator still connected as in IF alignment, adjust the generator to 1630 KC. Make sure that the gang condenser is turned to complete minimum capacity. Adjust the generator to 1630 KC. and adjust the oscillator trimmer of the receiver until a signal is tuned in. Next, turn the gang condenser to complete maximum capacity. Adjust the generator to 535 KC., then adjust the iron core in the end of the oscillator coil until the signal is tuned in. It may be well to recheck the 1630 KC. setting to make sure that the adjustment of the iron core has not shifted the frequency.

PART NO.	SYMBOL	DESCRIPTION
LO-18	L-2	Oscillator Coil
LI-10	T-1	I.F. Transformer Input
	SW	D.P.S.T. Switch (Part of Vol. Control)
	(T-2)	Speaker Transformer
SPK-21	(S)	Voice Coil
	T-3	P.M. Speaker
LI-11	CA-140	I.F. Transformer Output
	K-130	Complete Cabinet
	K-131	Volume Knob
TU-40		Tuning Knob
		Radio Tubes
CC-5	C-8	100 mfd. Ceramic Condenser
CC-3	C-9	.005 mfd. Ceramic Condenser
CC-20	C-10	.0015 mfd. Ceramic Condenser
EC-11	C-11	10 mfd. 70 V. Electrolytic Condenser
IR-20	R-5	220 K. 20% 1/2 Watt Resistor
IR-23	R-6	3.3 Meg. 20% 1/2 Watt Resistor
IR-39	R-7	620 10% 1/2 Watt Resistor
VC-40	R-8	1 meg. Volume Control
GC-12	(G-1)	Gang Condenser
LL-30	L-1	Loop Antenna

Westinghouse CHASSIS ASSEMBLY V-2237-2

MODELS H-511P4 H-512P4 (Coral)
(Gray)

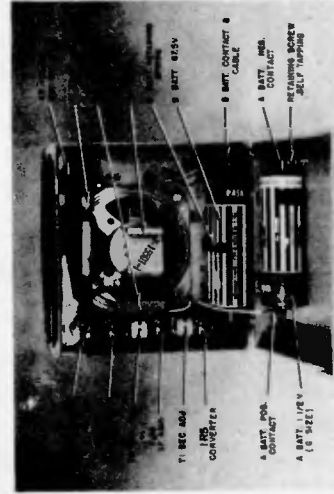
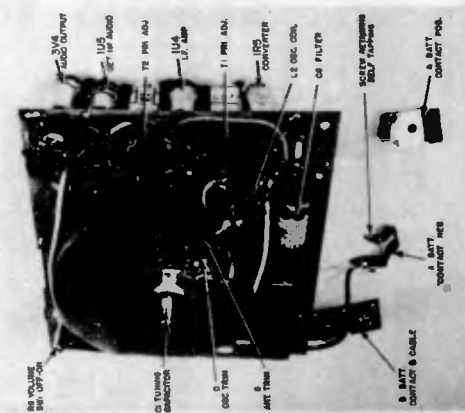
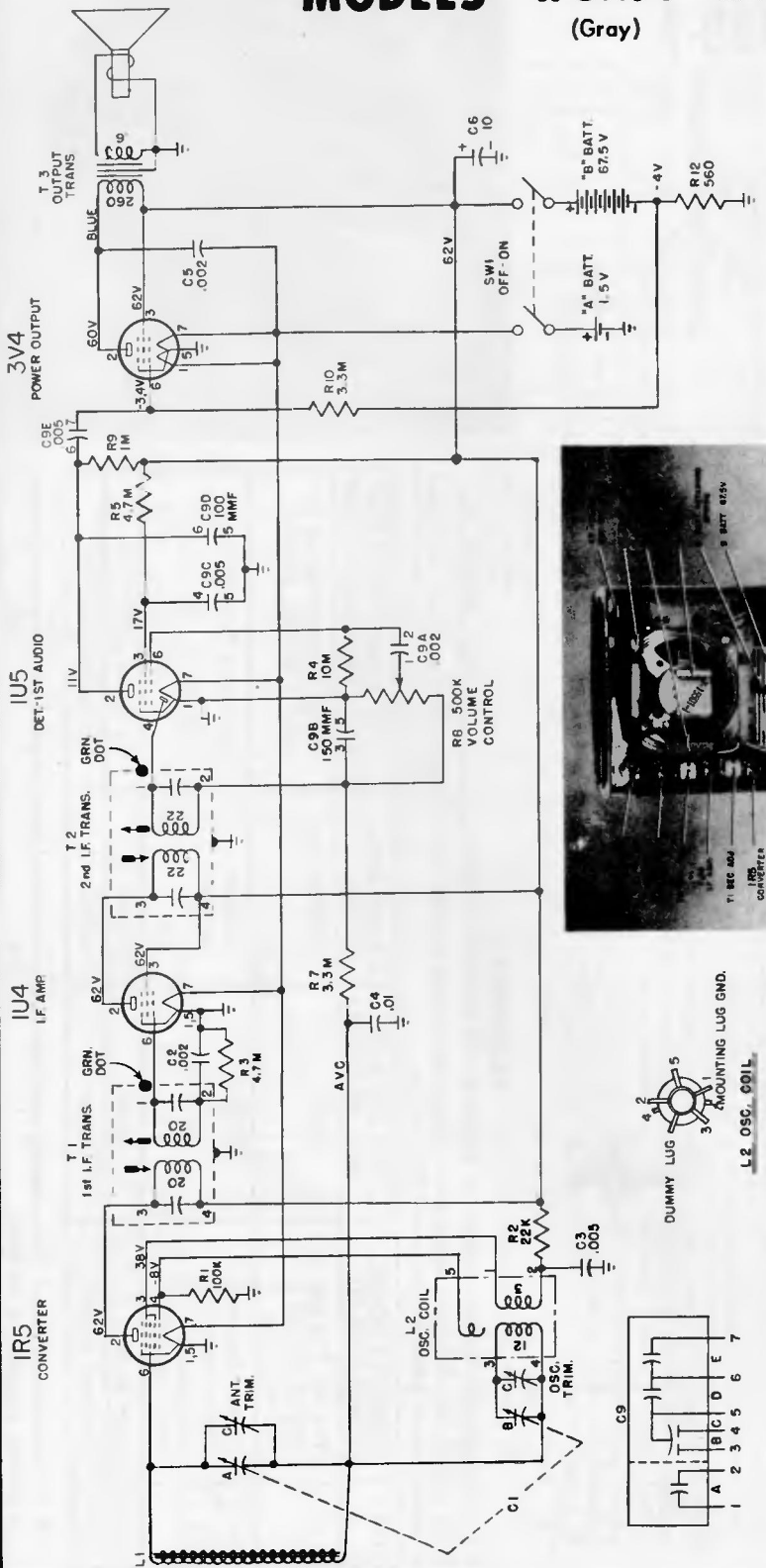

ALIGNMENT

While making the following adjustments, keep the volume control set for maximum output and the signal generator attenuated to avoid AVC action.

Step	Connect Signal Generator	Signal Generator Frequency	Radio Dial	Adjust for Maximum Output
1	Stator of R-F tuning capacitor (A), through a .01 mfd. capacitor	455 kc.	Minimum capacity	Top and bottom slugs in 2nd and 1st I-F trans. in order given
2	Radiated Signal	1600 kc.	Minimum capacity	Osc. trimmer (D)
3	Radiated Signal	1400 kc.	1400 kc.	Ant. trimmer (C)

- NOTES: 1. ALL VOLTAGES MEASURED FROM CHASSIS GROUND USING A V.T.V.M. READINGS SHOULD BE AS SHOWN ± 20 PER CENT.
2. ALL CAPACITANCE VALUES IN MFD AND ALL RESISTANCE VALUES IN OHMS UNLESS OTHERWISE STATED.

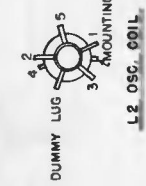

Westinghouse

CHASSIS V-2239-1, MODELS, H-523T4, H-524T4, H-525T4
 (BLACK) (IVORY) (CORAL)

CHASSIS V-2239-2, MODELS, H-538T4, H-539T4, H-540T4
 (BLACK) (IVORY) (CORAL)

The V-2239-1 chassis is basically the same as the V-2239-2 chassis, except that a clock is used with the V-2239-2 chassis and not with the V-2239-1. In the V-2239-1 chassis the off-on switch is ganged with the volume control and in the V-2239-2 chassis the off-on switch is part of the clock mechanism.

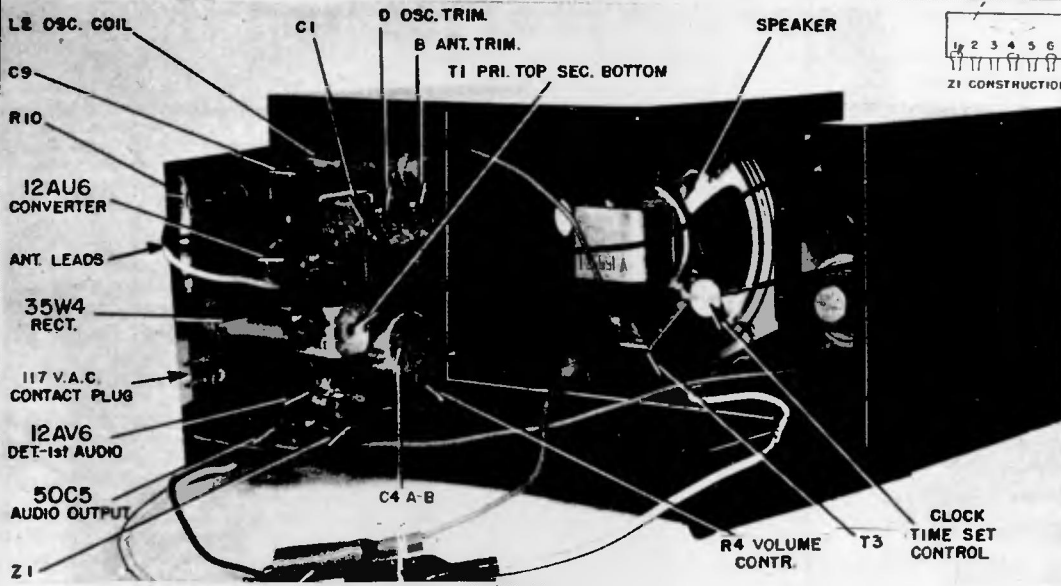
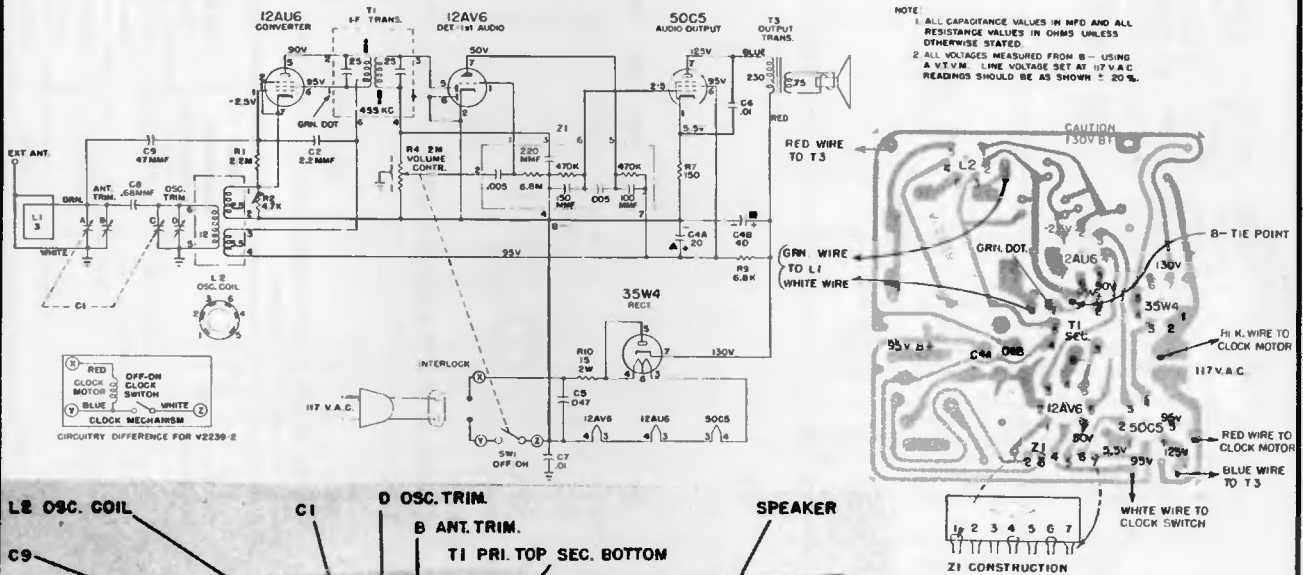

ALIGNMENT

It is recommended that the chassis be isolated from the power line by means of an isolation transformer. While making the following adjustments, keep the volume control set for maximum output and the signal generator output attenuated as much as possible. Connect VTVM across voice coil.

Step	Connect Signal Generator To:	Signal Generator Frequency	Tuning Capacitor	Adjust for Maximum Output
1.	Stator of tuning capacitor (A) through ø200 mmfd. capacitor and low side to B-.	455KC 400 Cycle 30% mod.	Minimum capacity	Top and bottom slugs of T1
2.	Radiated signal	1625KC	Minimum capacity	Oscillator trimmer (D)
3.	Radiated signal	1400KC	1400KC	Antenna trimmer (B)

To remove the printed board from the cabinet, remove the front control knobs then remove the screw mounting the printed board to the front of the cabinet. Remove the back cover, interlock and mounting button. Unsolder the blue lead from the output transformer and the white lead from the clock. The printed board can now be removed from the cabinet.

Westinghouse

Chassis Assembly V-2259-1, used in Models H-541T5, H-542T5, H-543T5, H-544T5, H-545T5, H-546T5.

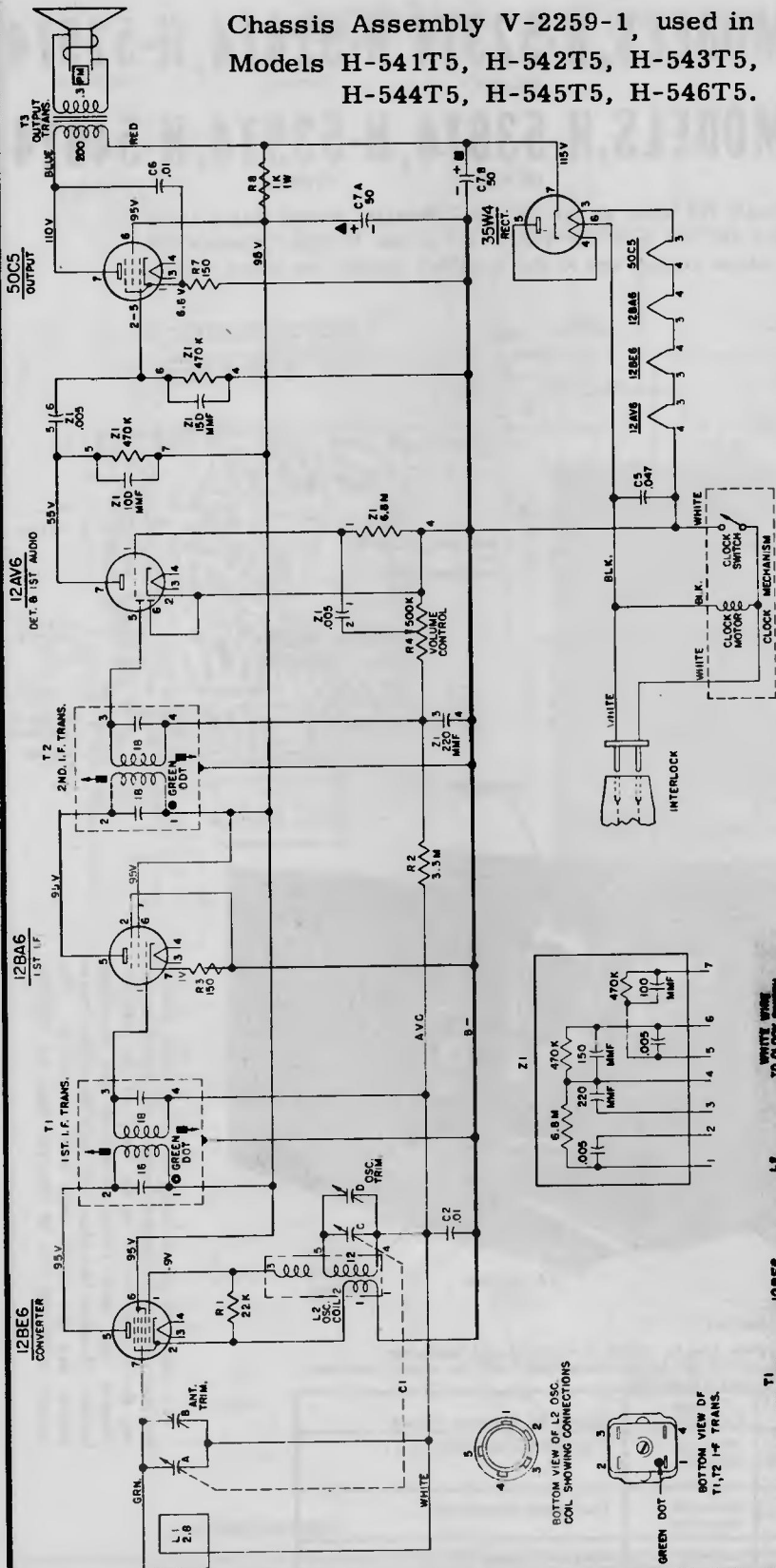

NOTES:
 1. ALL VOLTAGES MEASURED FROM COMMON NEGATIVE USING A V.T.V.M. AND NO SIGNAL INPUT. LINE VOLTAGE SET AT 117V AC. READINGS SHOULD BE ± 0.50 PER CENT.
 2. ALL CAPACITANCE VALUES IN MFD. AND ALL RESISTANCE VALUES IN OHMS UNLESS OTHERWISE SPECIFIED.

ALIGNMENT

While making the following adjustments, keep the volume control set for maximum output and the signal gen output attenuated to avoid AVC action.

Step	Connect Signal Generator to -	Signal Generator Frequency	Radio Dial	Connect V.T.V.M. Across Voice Coil and Adjust for Maximum Output -
1.	Stator of ant. tuning capacitor (A) through a 200 mmf capacitor	455 kc.	Minimum capacity	Top and bottom slugs of T2 and T1 in order given
2.	Same as step 1	1625 kc.	Minimum capacity	Oscillator trimmer (D)
3.	Radiated signal	1400 kc.	1400 kc.	Antenna trimmer (B)

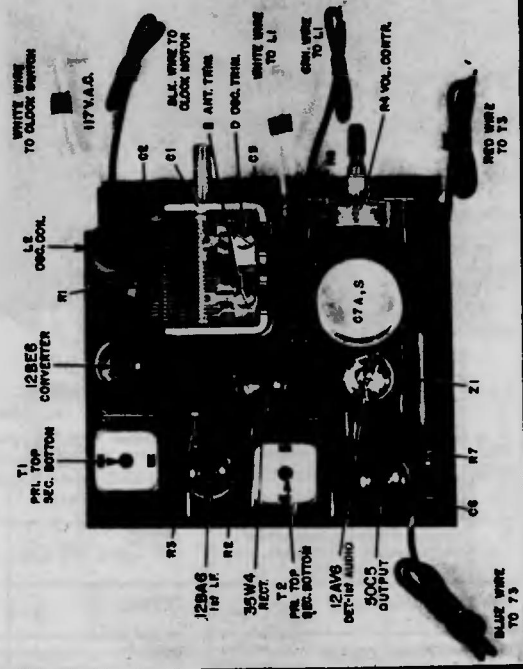

Westinghouse CHASSIS ASSEMBLY V-2261-1

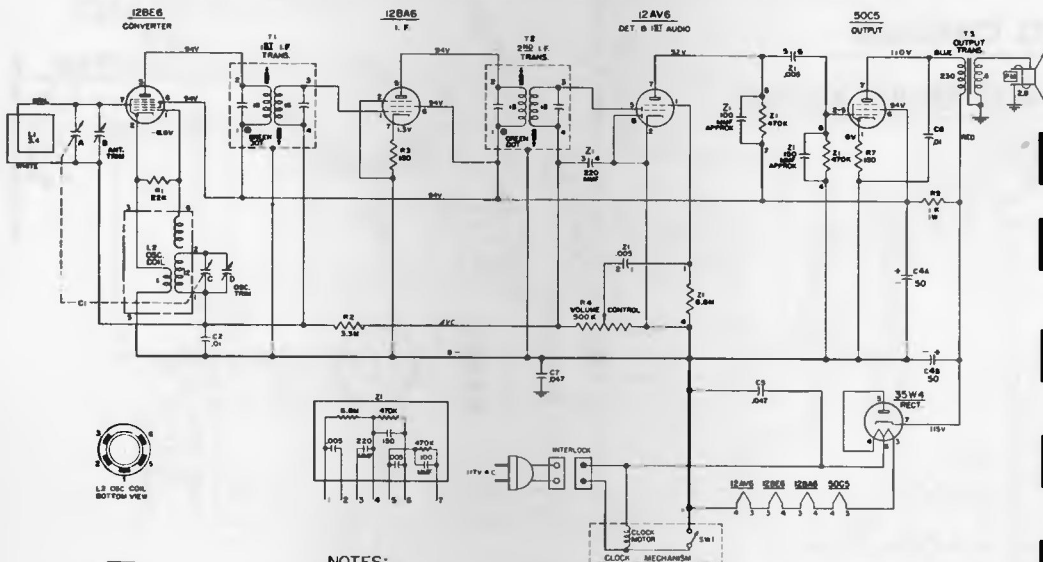

- MODELS**
- H-547T5**
(Gray)
- H-548T5**
(Ivory)
- H-549T5**
(Green)
- H-550T5**
(Rose)

NOTES:

1. ALL VOLTAGES MEASURED FROM COMMON NEGATIVE USING A V.T.V.M. AND NO SIGNAL INPUT. LINE VOLTAGE SET AT 117 V. A.C. READINGS SHOULD BE AS SHOWN ± 20 PER CENT.
2. ALL CAPACITANCE VALUES IN MFD. AND ALL RESISTANCE VALUES IN OHMS UNLESS OTHERWISE SPECIFIED.

ALIGNMENT

It is recommended that the chassis be isolated from the power line by means of an isolation transformer. While making the following adjustment, keep the volume control set for maximum output and the signal generator output attenuated as much as possible. Connect VTVM across voice coil.

Step	Connect Signal Generator To:	Signal Generator Frequency	Tuning Capacitor	VTVM Across Voice Coil and Adjust for Maximum Output
1	Stator of tuning capacitor (A) through a 200 mmfd. capacitor.	455KC 400 Cycle 30% mod.	Minimum capacity	Top and bottom slugs of T2 and T1 in order given*
2.	Radiated signal	1625 KC	Minimum capacity	Oscillator trimmer (D)
3.	Radiated signal	1400 KC	1400KC	Antenna trimmer (B)

* It is recommended that a fiber aligning tool that snugly fits the slot in the powdered iron core be used to prevent chipping of the slot.

CHASSIS REMOVAL

1. Remove the 3/4 inch self-tapping screw located at the bottom rear of the radio back cover.
2. Remove the two 4 1/4 inch phillip head bolts securing the back cover to the front rim and face assembly.
3. The chassis can now be removed for servicing.
Note: To remove the front rim and face assembly, remove the (4) 1/4" self-tapping screws, two from the top bracket assembly and two from the radio chassis.

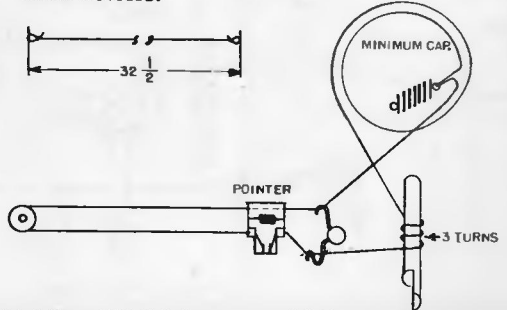
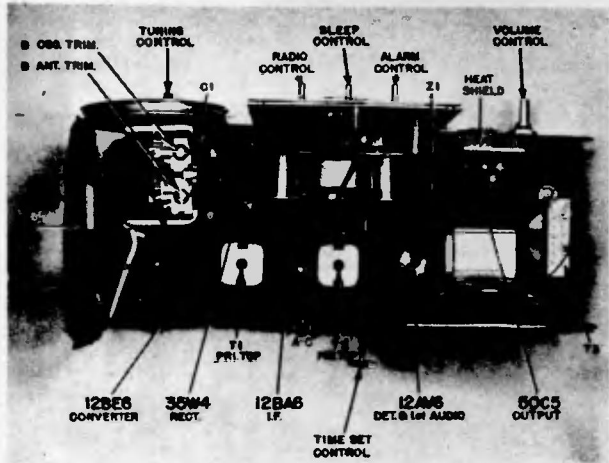

When extracting stubborn or troublesome components, the printed wiring may crack or break-off. Repairs can be made by soldering a small piece of tinned copper wire over the damaged or broken conductor (pig tail trimmings from capacitors and resistor, are ideal for this purpose).

ZENITH RADIO CORPORATION

3X01 CHASSIS -

To be used with Model X2280

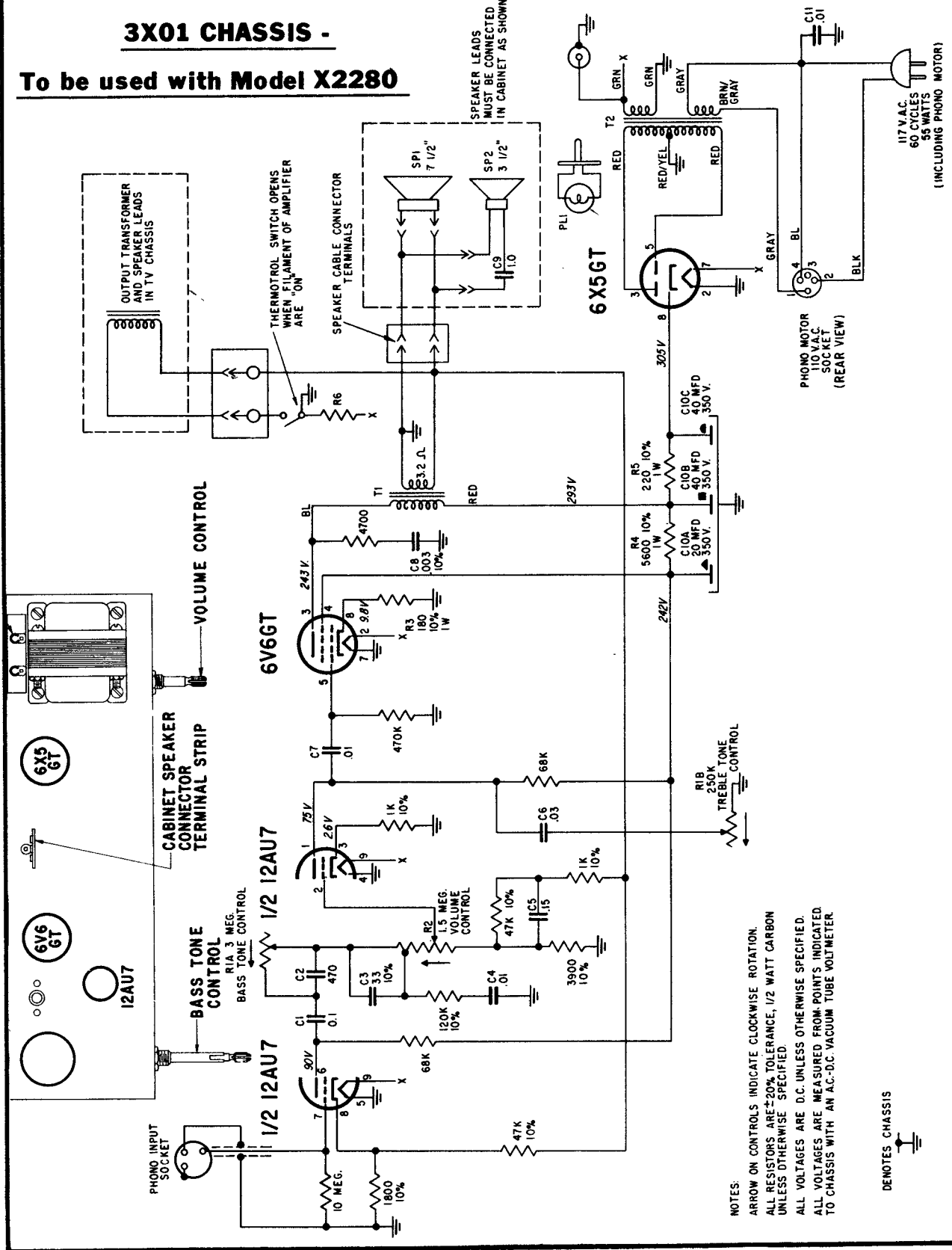

NOTES:
 ARROW ON CONTROLS INDICATE CLOCKWISE ROTATION.
 ALL RESISTORS ARE ±20% TOLERANCE, 1/2 WATT CARBON UNLESS OTHERWISE SPECIFIED.
 ALL VOLTAGES ARE D.C. UNLESS OTHERWISE SPECIFIED.
 ALL VOLTAGES ARE MEASURED FROM POINTS INDICATED TO CHASSIS WITH AN A.C.-D.C. VACUUM TUBE VOLTMETER.

⊥ DENOTES CHASSIS

ZENITH RADIO CORPORATION

**CHASSIS 3Y02
MODELS HFY17R
and HFY17E**

6V6GT

1/2 12AU7

1/2 12AU7

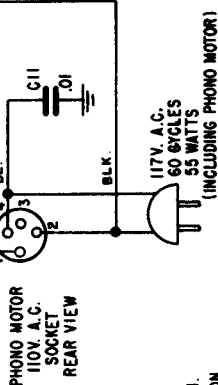
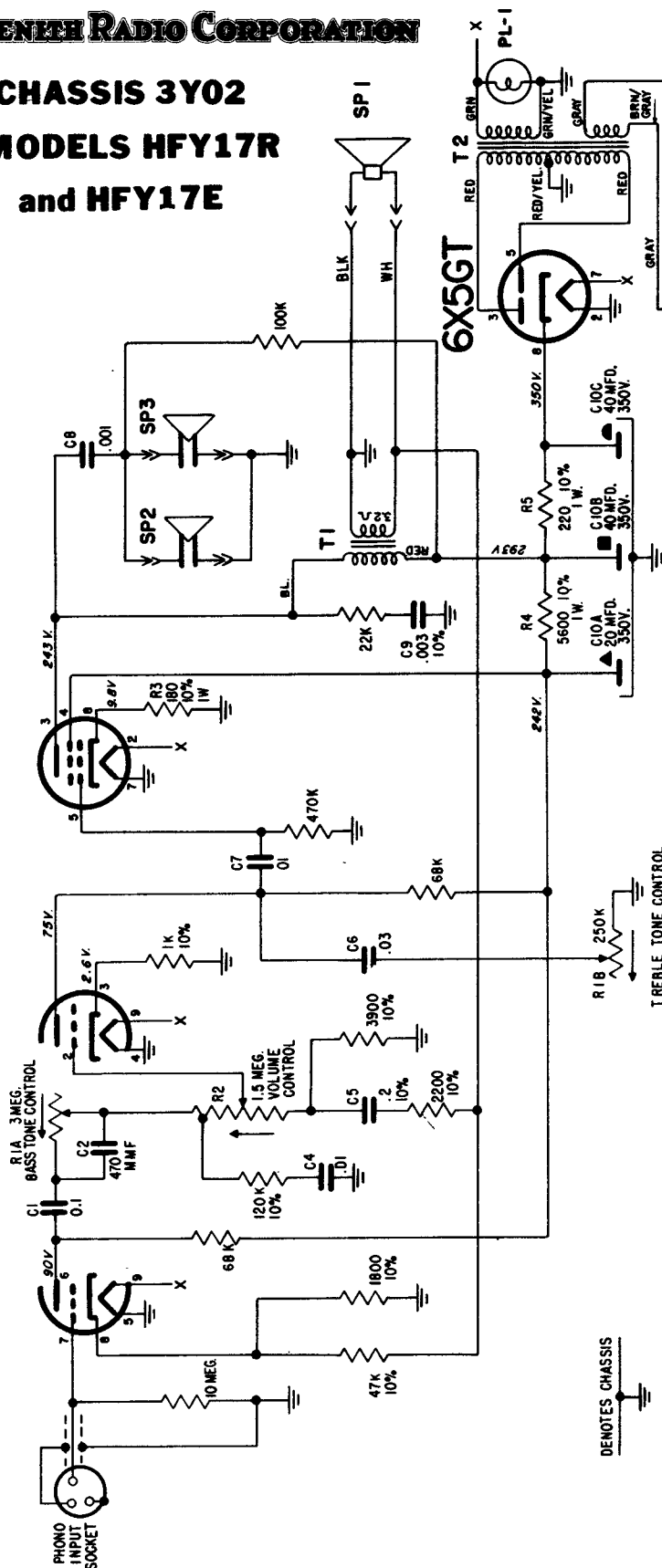

NOTES:
ARROW ON CONTROLS INDICATES CLOCKWISE ROTATION.
ALL RESISTORS ARE $\pm 20\%$ TOLERANCE, 1/2 WATT CARBON UNLESS OTHERWISE SPECIFIED.
ALL VOLTAGES ARE D.C. UNLESS OTHERWISE SPECIFIED.
ALL VOLTAGES ARE MEASURED FROM POINTS INDICATED TO CHASSIS WITH AN A.C. - D.C. VACUUM TUBE VOLTMETER.
ALL CAPACITORS ARE IN MICROFARADS UNLESS OTHERWISE SPECIFIED.

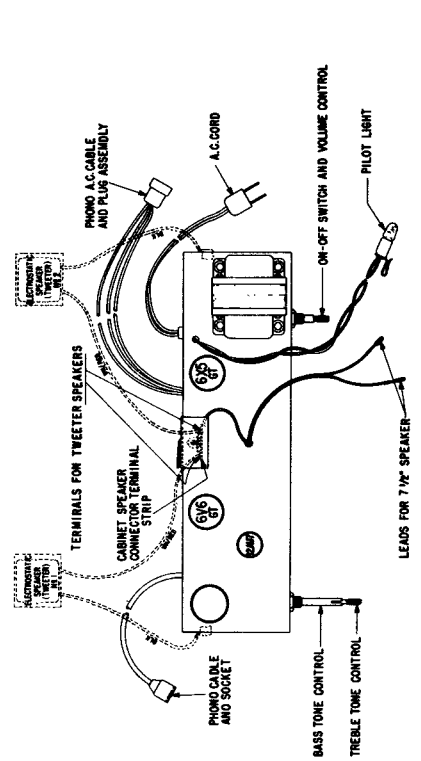

MODELS HFY17R and HFY17E CHASSIS 3Y02

6V6GT

1/2 12AU7

1/2 12AU7

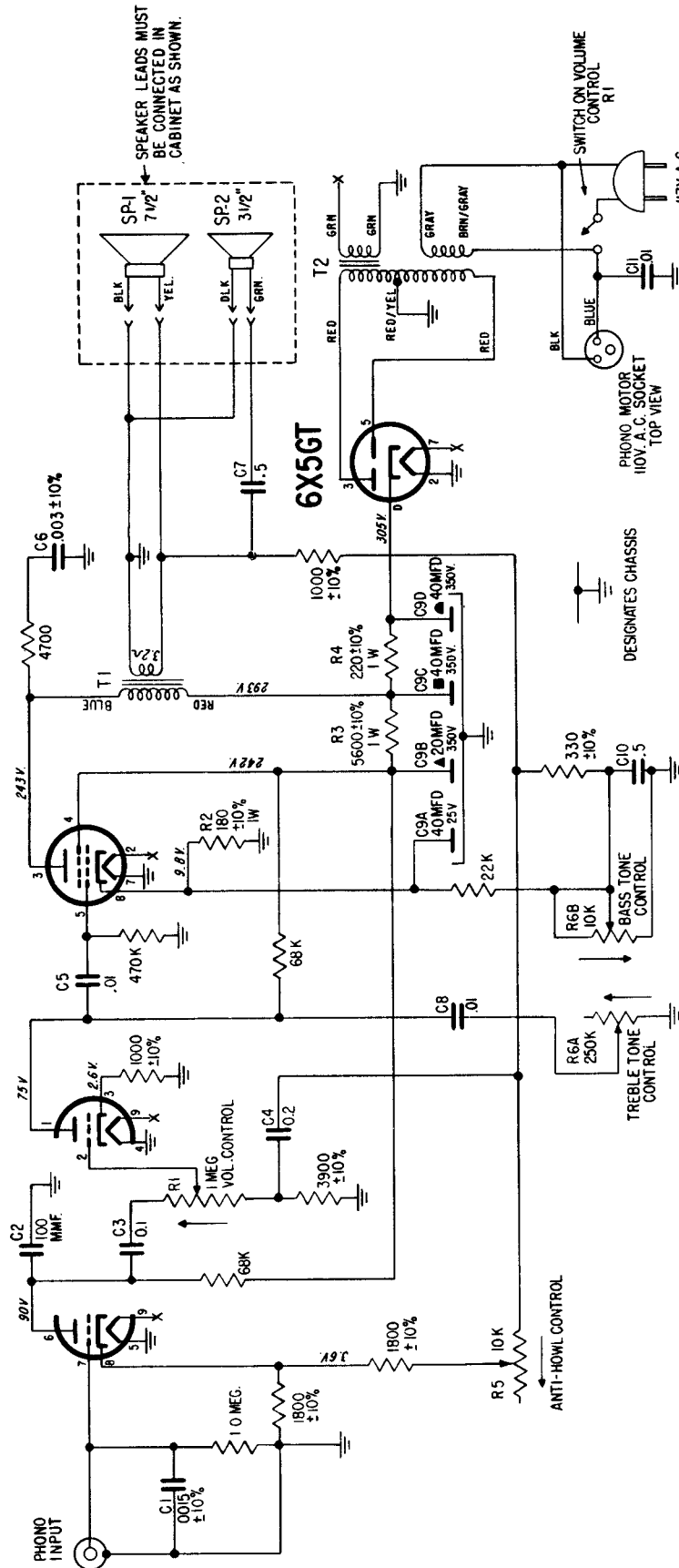

(INCLUDING PHONO MOTOR)

NOTES:
 R5 ANTI-HOWL CONTROL TO BE ADJUSTED FOR LOW OUTPUT AT THE TERMINALS OF THE 7V2" SPEAKER, USING THE 1000 CYCLE GROOVE OF A CLARKSTAN N.A.B. FREQUENCY RECORD NO. 20015, WITH THE VOLUME CONTROL IN THE MAXIMUM CLOCKWISE POSITION AND THE TONE CONTROLS IN THE MAXIMUM COUNTER-CLOCKWISE POSITION.
 ALL RESISTORS ARE $\pm 20\%$ TOLERANCE UNLESS OTHERWISE SPECIFIED.
 ALL VOLTAGES ARE D.C. UNLESS OTHERWISE SPECIFIED AND ARE MEASURED FROM POINTS INDICATED TO CHASSIS WITH AN A.C. D.C. VACUUM TUBE VOLTMETER WITH ANTI-HOWL CONTROL IN THE MAXIMUM CLOCKWISE POSITION.

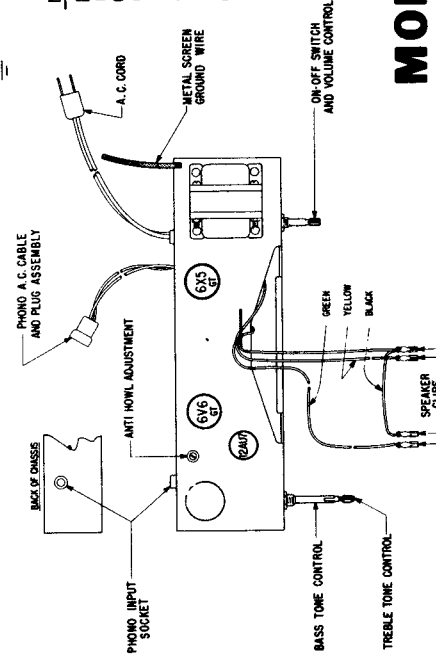

ZENITH RADIO CORPORATION

MODELS HFX14 AND HFX14E CHASSIS 3Y03

ZENITH RADIO CORP. MODELS HFY10Y, HFY10L, HFY12R & HFY12E

CHASSIS 3Y04

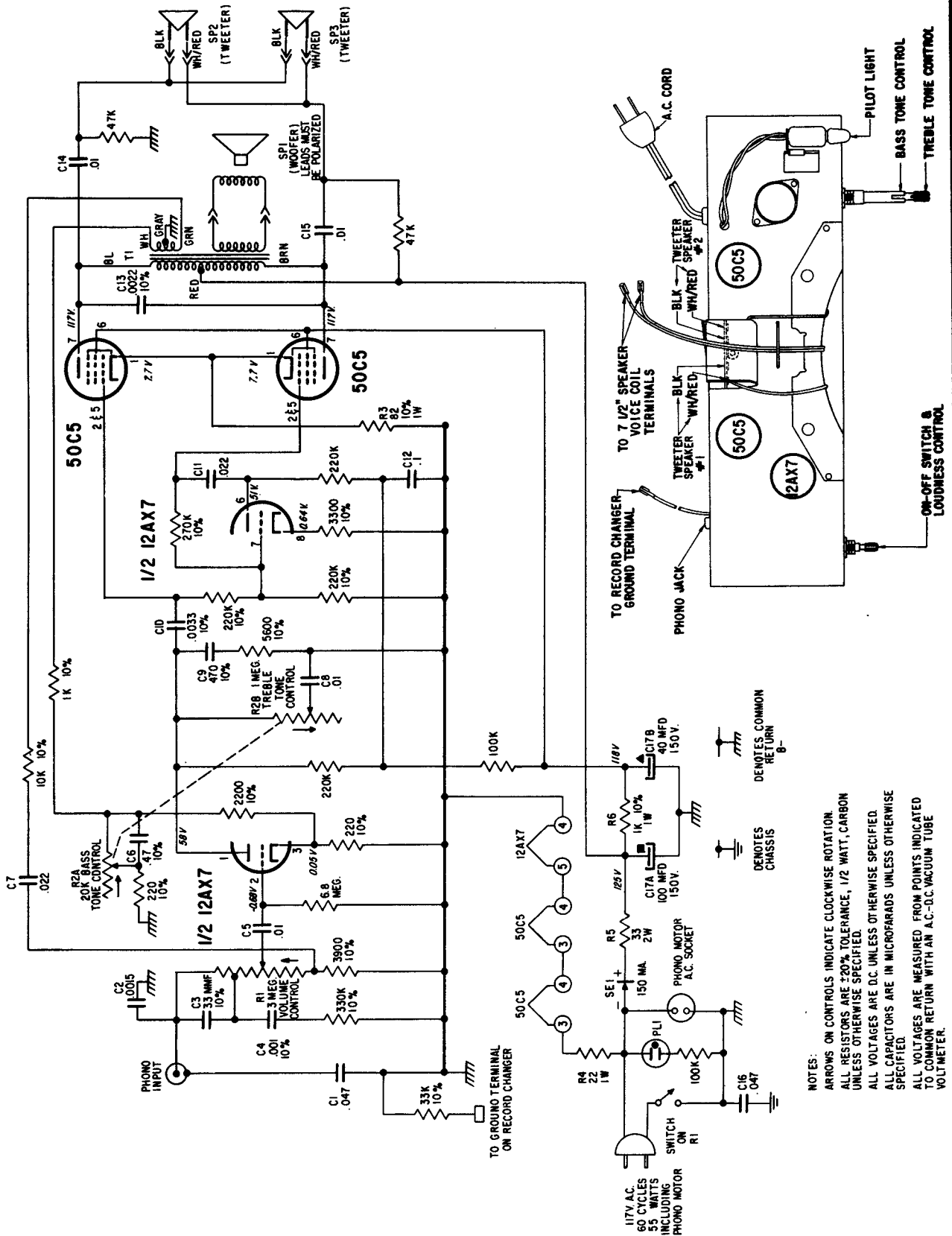

NOTES:
 ARROWS ON CONTROLS INDICATE CLOCKWISE ROTATION.
 ALL RESISTORS ARE 20% TOLERANCE, 1/2 WATT, CARBON UNLESS OTHERWISE SPECIFIED.
 ALL VOLTAGES ARE DC UNLESS OTHERWISE SPECIFIED.
 ALL CAPACITORS ARE IN MICROFARADS UNLESS OTHERWISE SPECIFIED.
 ALL VOLTAGES ARE MEASURED FROM POINTS INDICATED TO COMMON RETURN WITH AN A.C.-D.C. VACUUM TUBE VOLTMETER.

ZENITH RADIO CORPORATION MODELS HFY15R & HFY15E

CHASSIS 3Y05

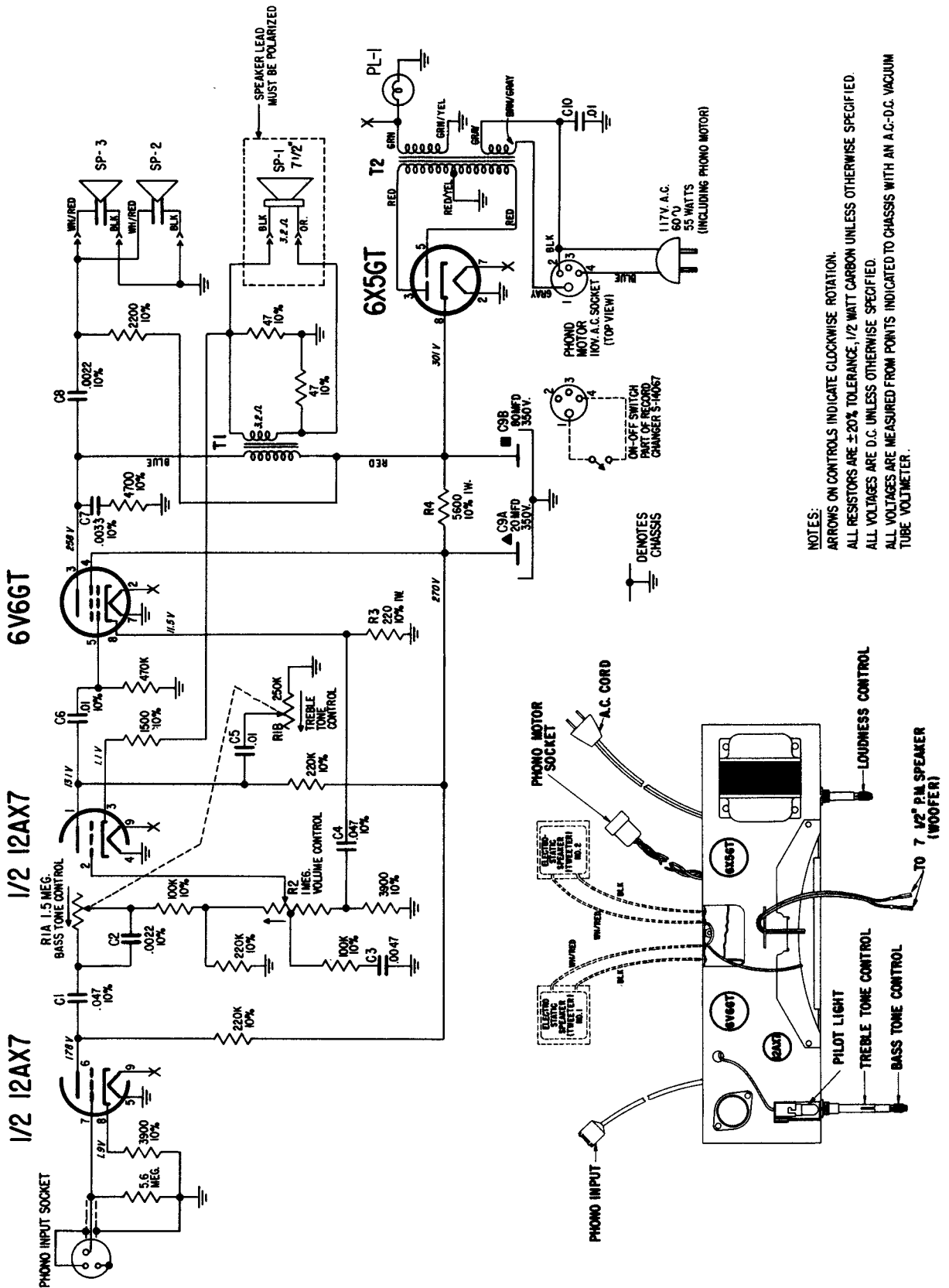

NOTES:
 ARROWS ON CONTROLS INDICATE CLOCKWISE ROTATION.
 ALL RESISTORS ARE ±20% TOLERANCE, 1/2 WATT CARBON UNLESS OTHERWISE SPECIFIED.
 ALL VOLTAGES ARE D.C. UNLESS OTHERWISE SPECIFIED.
 ALL VOLTAGES ARE MEASURED FROM POINTS INDICATED TO CHASSIS WITH AN A.C.-D.C. VACUUM TUBE VOLTMETER.

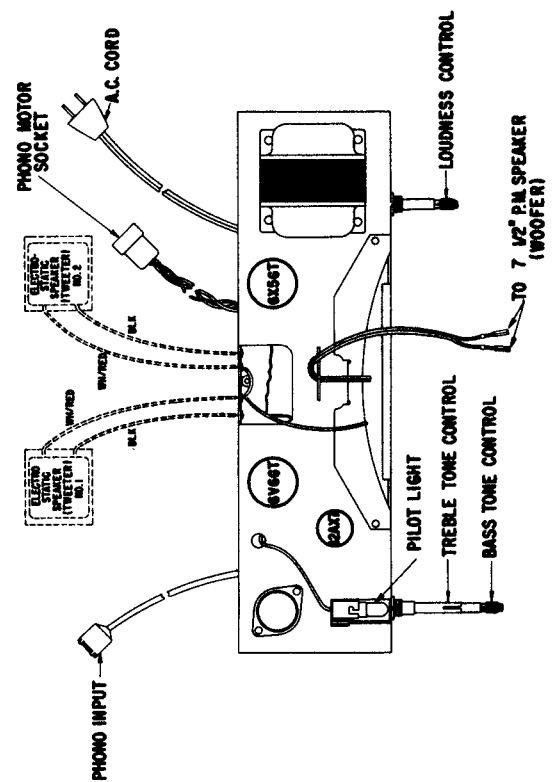

ZENITH RADIO CORPORATION

MODEL T404F, L, P, V & W CHASSIS 4T40

MODEL T405F, L, P, V & W CHASSIS 4T41

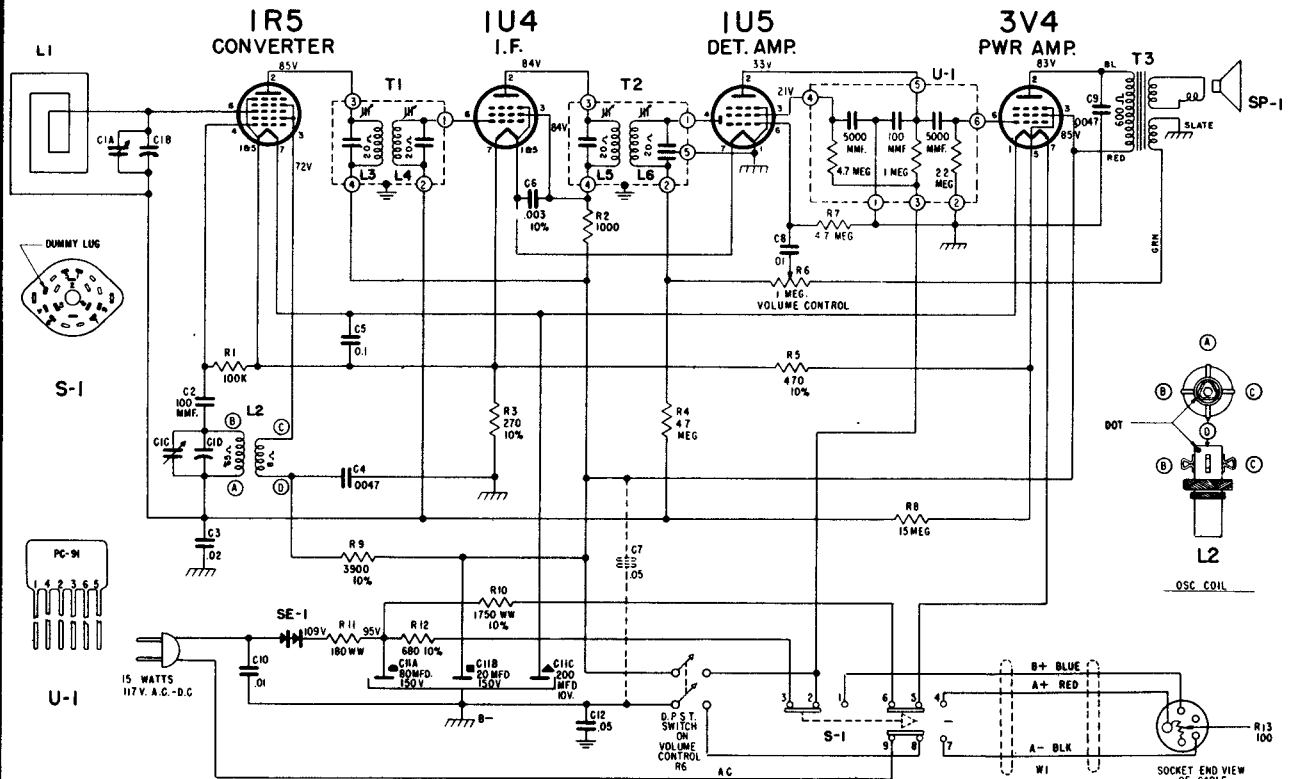
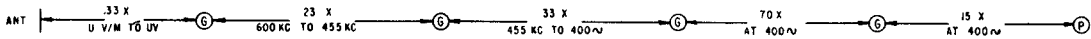

NOTES
 ALL VOLTAGES MEASURED FROM COMMON RETURN TO POINTS INDICATED WITH A C, DC OR VACUUM TUBE VOLTMETER.
 ALL VOLTAGES ARE DC UNLESS OTHERWISE SPECIFIED.
 ALL CONDENSERS MICROFARADS UNLESS OTHERWISE SPECIFIED.
 ALL CONDENSERS AND RESISTORS ±20% UNLESS OTHERWISE SPECIFIED.
 USE ONLY ZENITH NON-INDUCTIVE ELECTROLYTIC CONDENSERS FOR REPLACEMENT.
 IF ANY OTHER TYPE ELECTROLYTIC IS USED, IT WILL BE NECESSARY TO ADD C7 SHOWN IN BOTTED LINES.

I. F. FREQUENCY 455 KC
 TUNING RANGE 450 KC 1600 KC

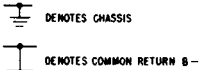

BATTERY PACK NO Z775

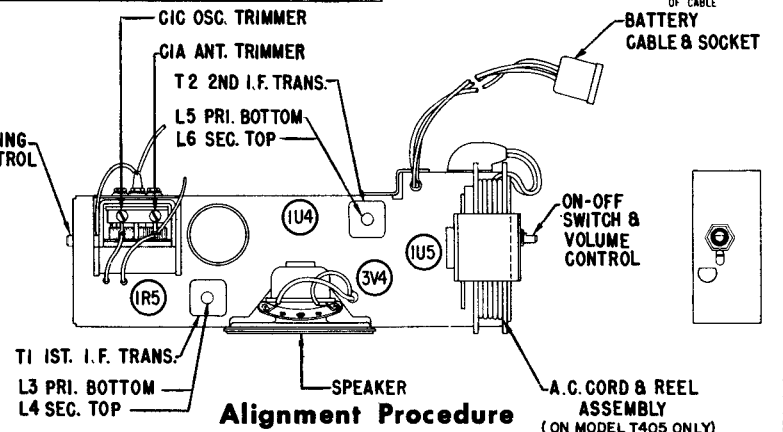
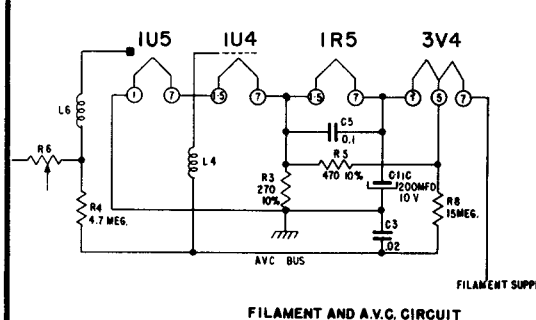
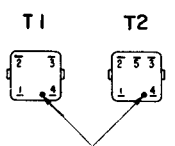

OPERATION	CONNECT OSC. TO	DUMMY ANTENNA	INPUT SIG. FREQUENCY	SET DIAL AT	TRIMMERS	PURPOSE
1	Converter Grid	.5 Mfd.	455 Kc.	600 Kc.	L3, 4, 5, 6	For I.F. Alignment
2	Single Turn Loosely Coupled to Wave-Magnet	1600 Kc.	1600 Kc.	C1C	Set Osc. to Dial Scale
3	1400 Kc.	1400 Kc.	C1A	Antenna Alignment

Zenith Radio Corporation

MODEL Y513R, W, G, F

CHASSIS 5Y01

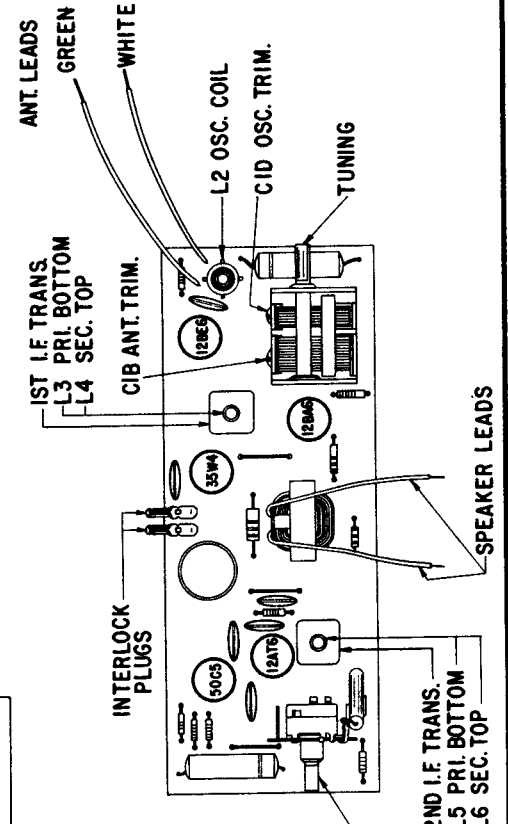
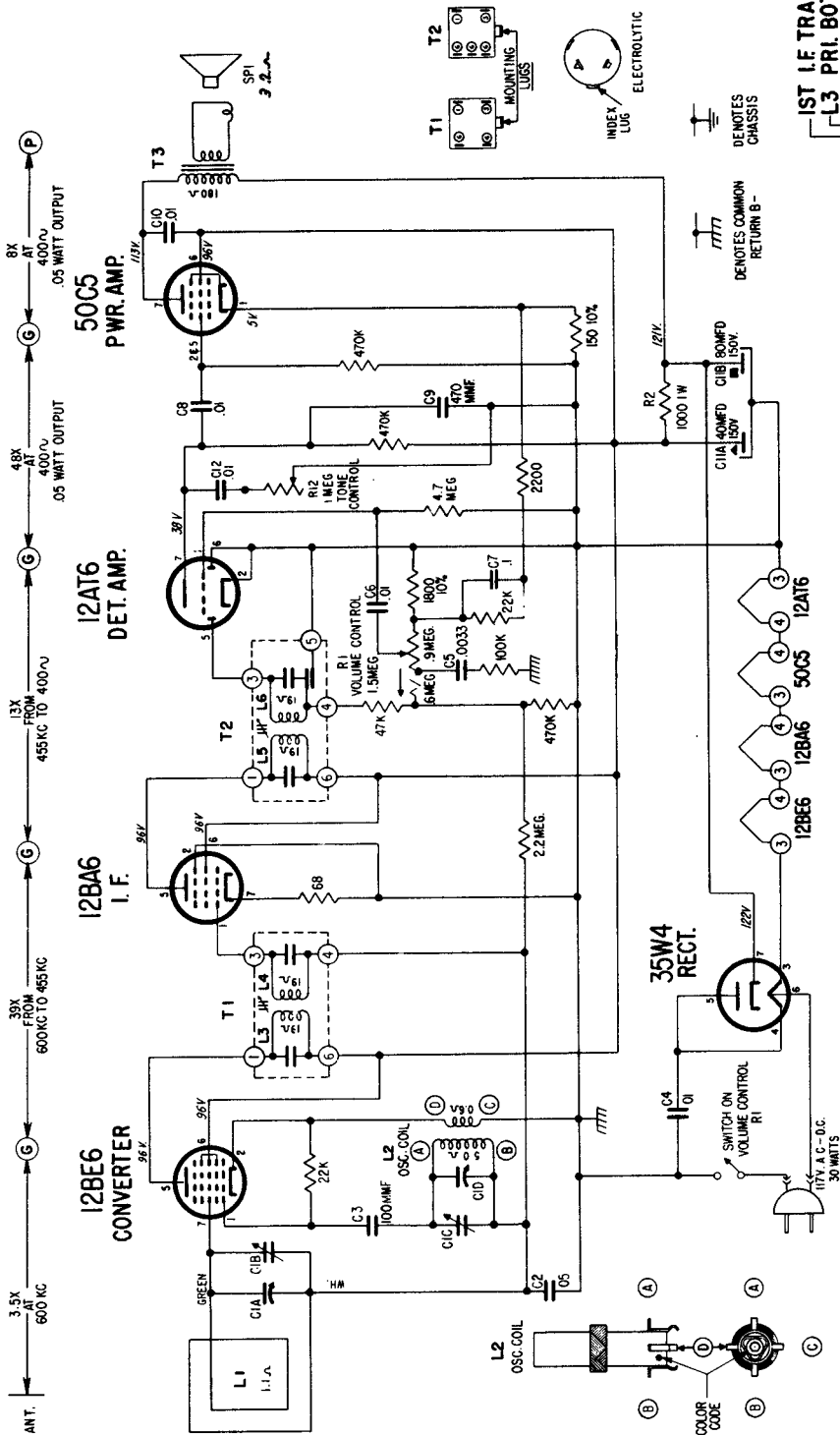

ALIGNMENT PROCEDURE

OPERATION	CONNECT DSCALATOR TO ANTENNA	DUMMY ANTENNA	INPUT FREQ. FREQUENCY	SET DIAL AT	TRIMMERS	PURPOSE
1	Converter Grid	.5 MFD.	455 Kc.	600 Kc.	L3, L4, L5, L6	Align I.F. for maximum output
2	One Turn Loop Coupled Loosely to Wave Magnet	—	1600 Kc.	1600 Kc.	C1D	Set Oscillator to Dial Scale.
3	—	—	1400 Kc.	1400 Kc.	C1B	Align Antenna Stage

ON-OFF SWITCH & VOLUME CONTROL

NOTES:
 ALL VOLTAGES MEASURED FROM COMMON RETURN TO POINTS INDICATED WITH AN A.C.-D.C. OR VACUUM TUBE VOLTMETER.
 ALL VOLTAGES ARE D.C. UNLESS OTHERWISE SPECIFIED.
 ALL RESISTORS 2.0% TOLERANCE, 1/2 WATT, CARBON UNLESS OTHERWISE SPECIFIED.
 I.F. FREQUENCY 455 KC.
 TUNING RANGE 535-1620KC.

ZENITH RADIO CORPORATION

MODELS T521F, G, R, W & Y CHASSIS 5T03

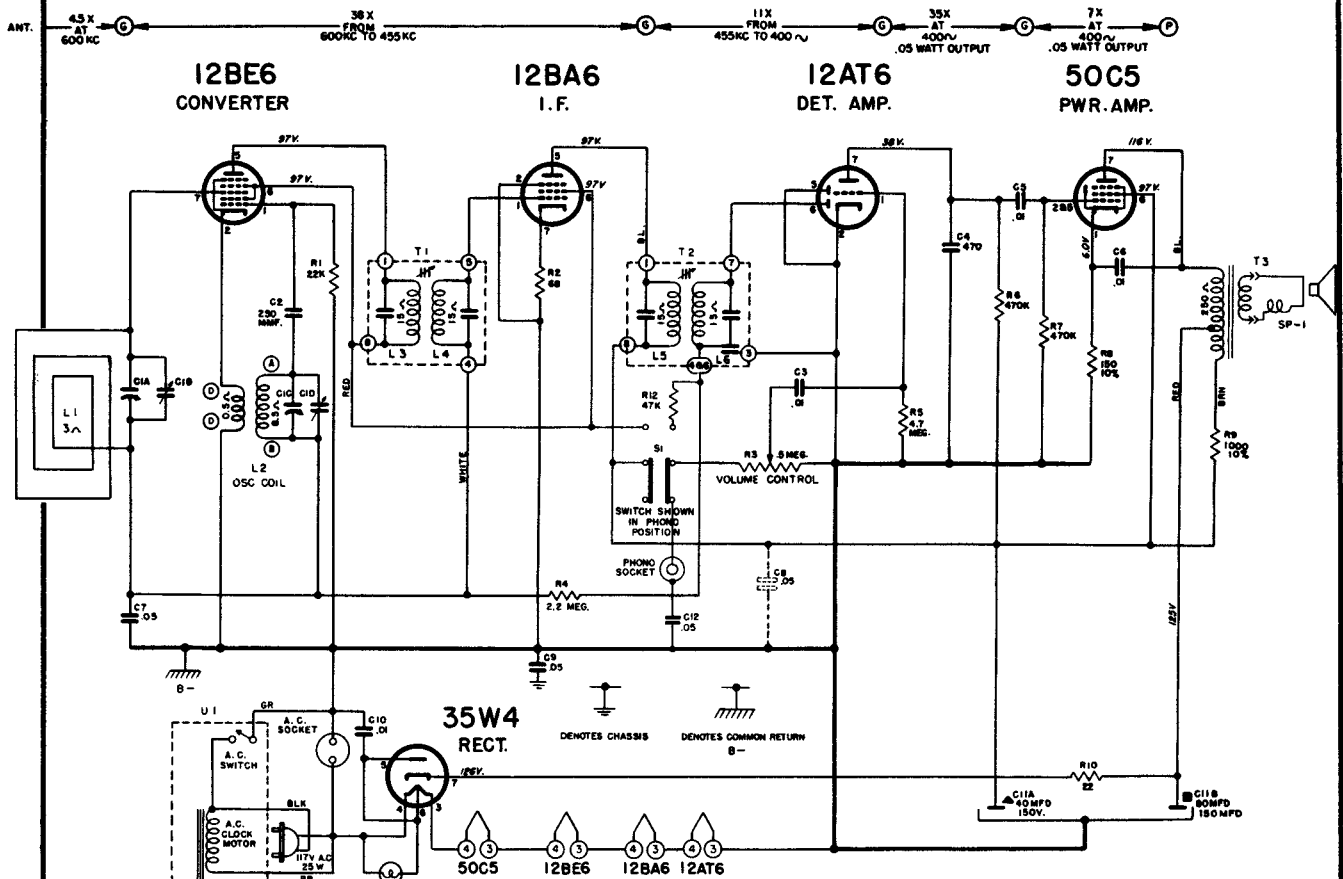

ALIGNMENT PROCEDURE

Operation	Connect Oscillator To	Dummy Antenna	Input Sig. Frequency	Set Dial At	Trimmers	Purpose
1	Converter Grid	.5 Mfd.	455 Kc.	600 Kc.	L3, L4, L5, L6	For I.F. Alignment.
2	One Turn Loop Coupled Loosely to Wave Magnet	—	1600 Kc.	1600 Kc.	C1D	Set Oscillator to Dial Scale
3	—	—	1400 Kc.	1400 Kc.	C1B	Align Antenna Stage

2/3 TURNS AROUND LARGE PULLEY

2 1/2 TURNS AROUND SHAFT

DIAL CORD DRIVE

NOTES:

ALL VOLTAGES MEASURED FROM COMMON RETURN TO POINTS INDICATED WITH AN A.C., D.C. OR VACUUM TUBE VOLTMETER.
 ALL VOLTAGES ARE D.C. UNLESS OTHERWISE SPECIFIED.
 ALL RESISTORS ± 20% TOLERANCE UNLESS OTHERWISE SPECIFIED.
 USE ONLY ZENITH NON-INDUCTIVE ELECTROLYTIC CONDENSERS FOR REPLACEMENT.
 IF ANY OTHER TYPE OF ELECTROLYTIC IS USED IT WILL BE NECESSARY TO ADD C8 SHOWN IN DOTTED LINES.
 I.F. TRANSFORMER NUMBERING STARTS WITH #1 TERMINAL, AS FIRST TERMINAL CLOCKWISE AND ADJACENT TO MARKER AG VIEWED FROM BOTTOM OF CHASSIS.

I.F. FREQUENCY 455 KC.
 TUNING RANGE
 535 - 1620 KC.

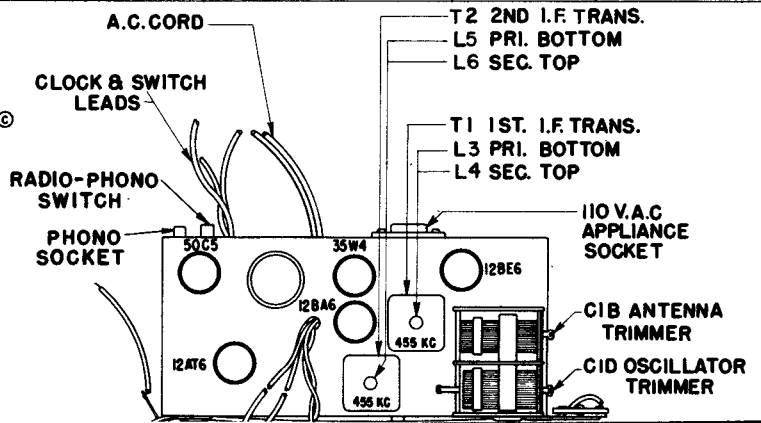

ZENITH RADIO CORPORATION

MODELS T522R, G, W, V & F CHASSIS 5T06

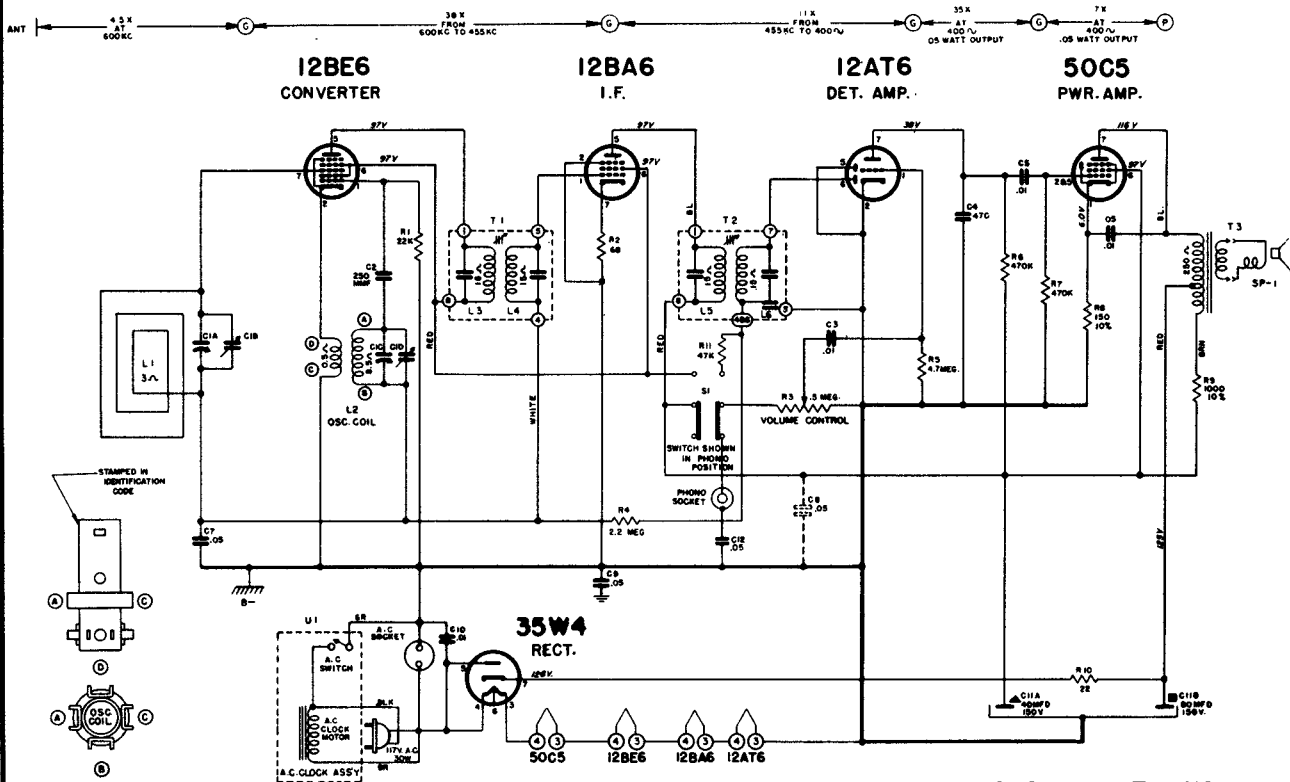

NOTES:
 ALL VOLTAGES MEASURED FROM COMMON RETURN TO POINTS INDICATED WITH AN A.C., D.C. OR VACUUM TUBE VOLTMETER.
 ALL VOLTAGES ARE D.C. UNLESS OTHERWISE SPECIFIED.
 ALL RESISTORS ± 20% TOLERANCE UNLESS OTHERWISE SPECIFIED.
 USE ONLY ZENITH NON-INDUCTIVE ELECTROLYTIC CONDENSERS FOR REPLACEMENT.
 IF ANY OTHER TYPE OF ELECTROLYTIC IS USED IT WILL BE NECESSARY TO ADD OS SHOWN IN DOTTED LINES.
 I.F. TRANSFORMER NUMBERING STARTS WITH "1" TERMINAL, AS FIRST TERMINAL CLOCKWISE AND ADJACENT TO MARKER AS VIEWED FROM BOTTOM OF CHASSIS.

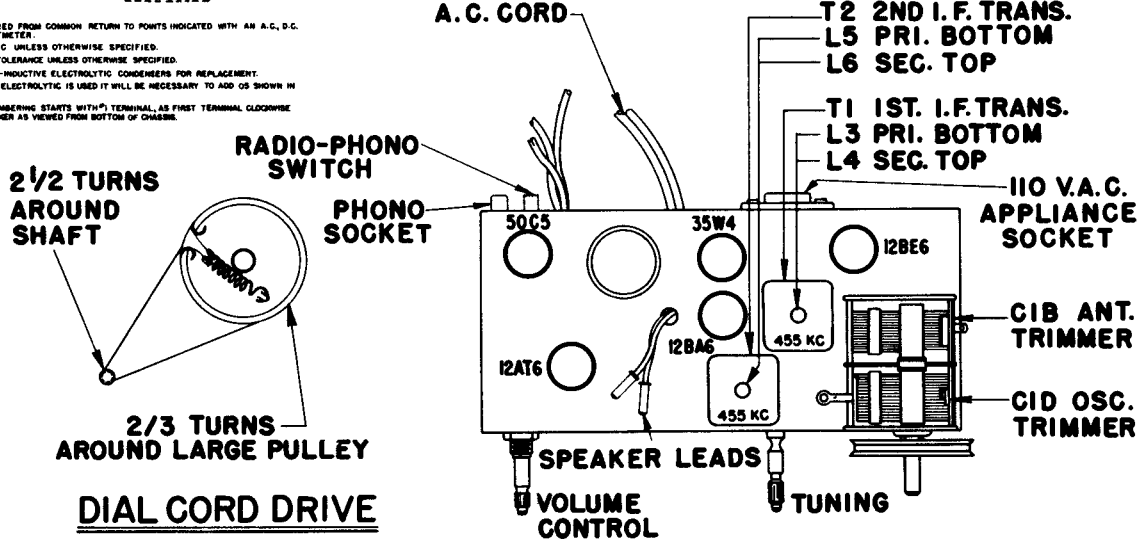

ALIGNMENT PROCEDURE

OPERATION	CONNECT OSCILLATOR TO	DUMMY ANTENNA	INPUT SIG. FREQUENCY	SET DIAL AT	TRIMMERS	PURPOSE
1	Converter Grid	.5 Mfd.	455 Kc.	600 Kc.	L3, 4, 5, 6	For I.F. Alignment
2	One Turn Loop Coupled Loosely to Wave Magnet	—	1600 Kc.	1600 Kc.	C1D	Set Oscillator to Dial Scale
3		—	1400 Kc.	1400 Kc.	C1B	Align Antenna Stage

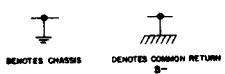

ZENITH RADIO CORPORATION

MODEL X514V & W CHASSIS 5X06
MODEL 519F, G, R & W CHASSIS 5X07

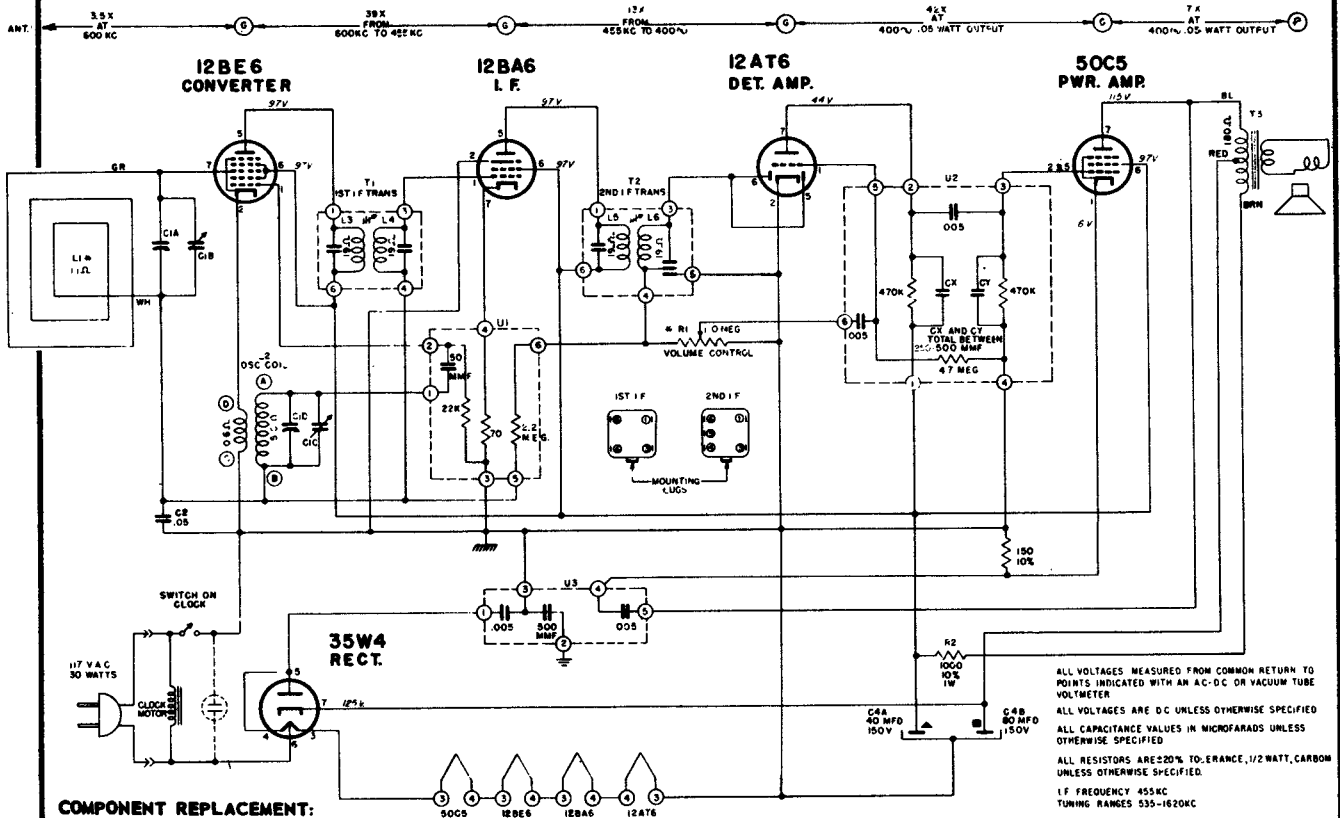

ALL VOLTAGES MEASURED FROM COMMON RETURN TO POINTS INDICATED WITH AN A.C.-D.C. OR VACUUM TUBE VOLTMETER
ALL VOLTAGES ARE D.C. UNLESS OTHERWISE SPECIFIED
ALL CAPACITANCE VALUES IN MICROFARADS UNLESS OTHERWISE SPECIFIED
ALL RESISTORS ARE 20% TOLERANCE, 1/2 WATT, CARBON UNLESS OTHERWISE SPECIFIED
I.F. FREQUENCY 455KC
TUNING RANGES 535-1620KC

COMPONENT REPLACEMENT:

Resistors, capacitors and integners should be replaced by clipping out the defective part and neatly soldering in the new part.

If a unit, such as the oscillator coil or I.F. transformer is to be removed, heat the mounting lugs with a pencil type soldering iron and move them away from the soldered connection with a long nose pliers or metal pick. Continue heating the lugs and brush away the molten solder with a small stiff glue brush. Remove the defective unit by lifting it off the chassis. Before inserting the new unit, be certain that the lug holes are open and free from solder. Forcing a lug against a solder filled lug hole may break the bond between the chassis base and the "printed" wiring. It is, therefore, necessary to exercise care when replacing units.

An open or damaged section of "printed" circuit wiring can be replaced by soldering a short jumper wire across the points to be connected.

I. F. TRANSFORMERS:

The I.F. transformers incorporated in this receiver are of the new permeability tuned type. The advantage of an I.F. transformer of this type is its extreme stability under various humidity and temperature conditions. The upper coil is the secondary and the lower the primary. When adjusting these I.F. transformers, the tuning wrench 68-19 can be inserted into the top slug, rotated until maximum output is obtained and then dropped down to the lower slug and the same operation repeated.

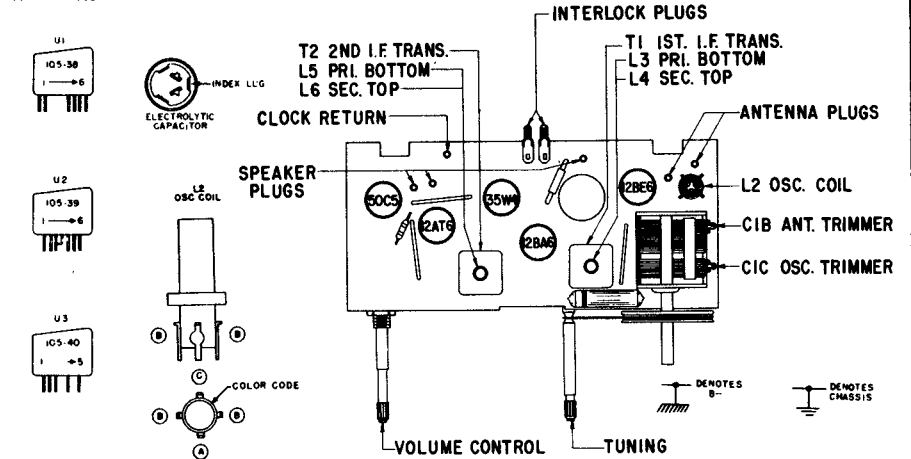

ALIGNMENT PROCEDURE:

OPERATION	CONNECT OSCILLATOR TO	DUMMY ANTENNA	INPUT SIG. FREQUENCY	SET DIAL AT	TRIMMERS	PURPOSE
1	Converter Grid	.5 Mfd.	455 Kc.	600 Kc.	L3, L4, L5, L6	Align I.F. for maximum output
2	One Turn Loop Coupled Loosely to Wave Magnet	—	1600 Kc.	1600 Kc.	C1C	Set Oscillator to Dial Scale.
3		—	1400 Kc.	1400 Kc.	C1B	Align Antenna Stage



ZENITH RADIO COPR.
 Alignment Information for
 Model T723, Chassis 7T04,
 Model T724, Chassis 7T02,
 Model X733G, -R, -Y,
 Chassis 7X03.

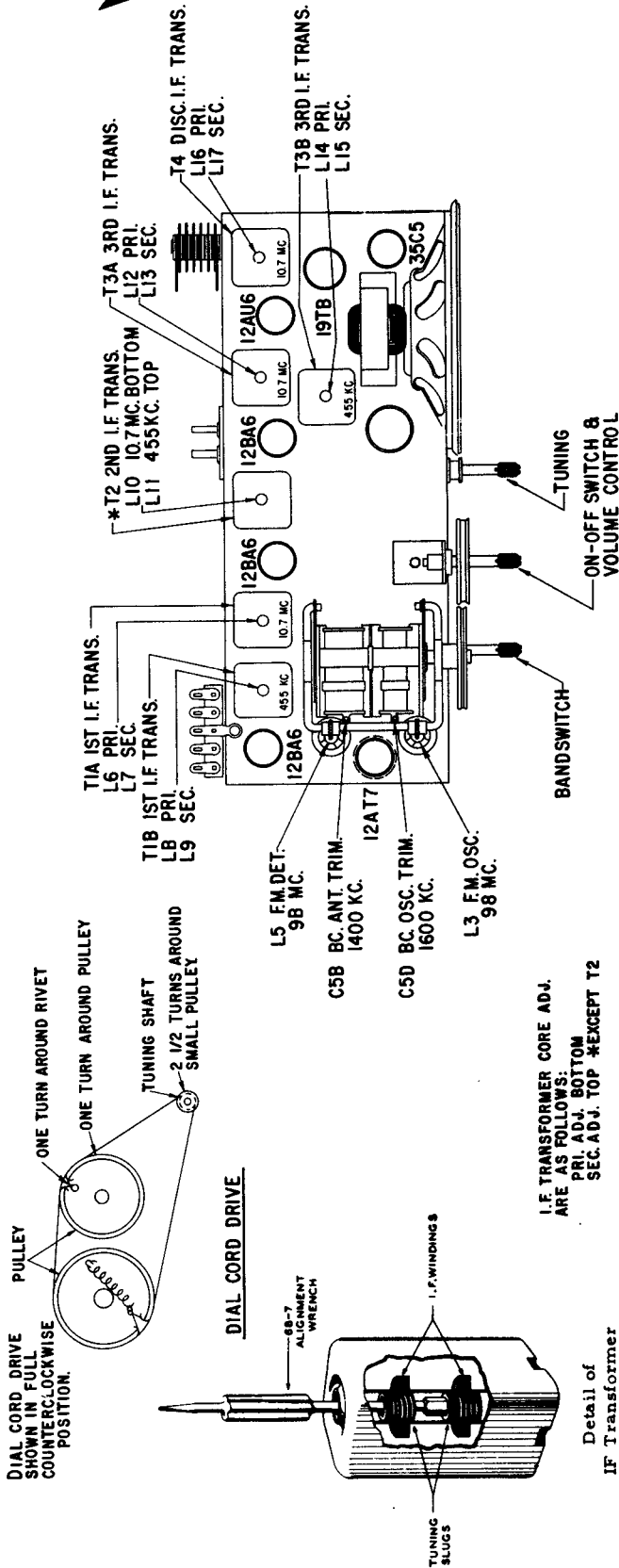

A L I G N M E N T P R O C E D U R E

Operation	Connect Oscillator to	Dummy Antenna	Input Signal Frequency	Band	Set Dial To	Adj. Trimmers	Purpose
1	Pin 2-12AT7 Converter	.05 Mfd.	455 Kc. Modulated	BC	600 Kc.	L8, 9, 11, 14, 15	Align I. F. channel for maximum output. Set oscillator to dial scale.
2	2 turns loosely cpd. to wavemagnet		1600 Kc. Modulated	BC	1600 Kc.	C5D	Align antenna stage.
3	2 turns loosely cpd. to wavemagnet		1400 Kc. Modulated	BC	1400 Kc.	C5B	Align primary of discriminator for maximum reading.
4 (a)	Pin 1 (grid) on 12AU6 limiter.	.05 Mfd.	10.7 Mc. Unmodulated	FM		L16 coil slug	Adjust secondary of discriminator or for zero reading.
5 (b)	Pin 1 (grid) on 12AU6 limiter.	.05 Mfd.	10.7 Mc. Unmodulated	FM		L17 coil slug	Align 3rd IF transformer for maximum reading.
6 (c)	Pin 1 (grid) on 12BA6 2nd IF.	.05 Mfd.	10.7 Mc. Unmodulated	FM		L12 and 13 Prim. and Sec. of 3rd IF trans.	Align 2nd IF transformer for maximum reading.
7 (c)	Pin 1 (grid) on 12BA6 1st IF.	.05 Mfd.	10.7 Mc. Unmodulated	FM		L6 and L7 Prim. and Sec. of 1st IF transformer.	Align 1st IF transformer for maximum reading.
9 (c)	Antenna Post FM (Remove line ant.)	270 ohms	98 Mc. Unmodulated	FM	98 Mc.	L3 Osc. Coil.	Set Oscillator to dial scale.
10 (c) (d)		270 ohms	98 Mc. Unmodulated	FM	98 Mc.	L5 Det. Coil.	Align det. stage to maximum reading.

ZENITH RADIO CORPORATION MODEL YP6B & YP6F

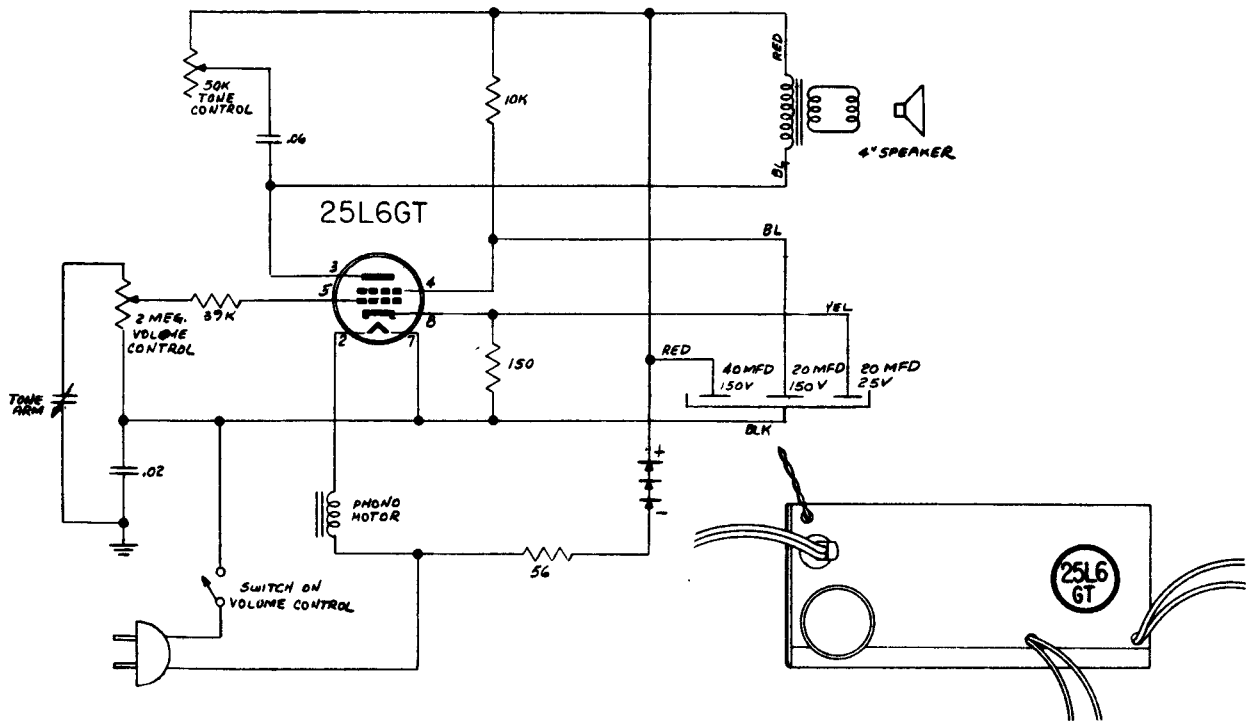

MODEL YP8L

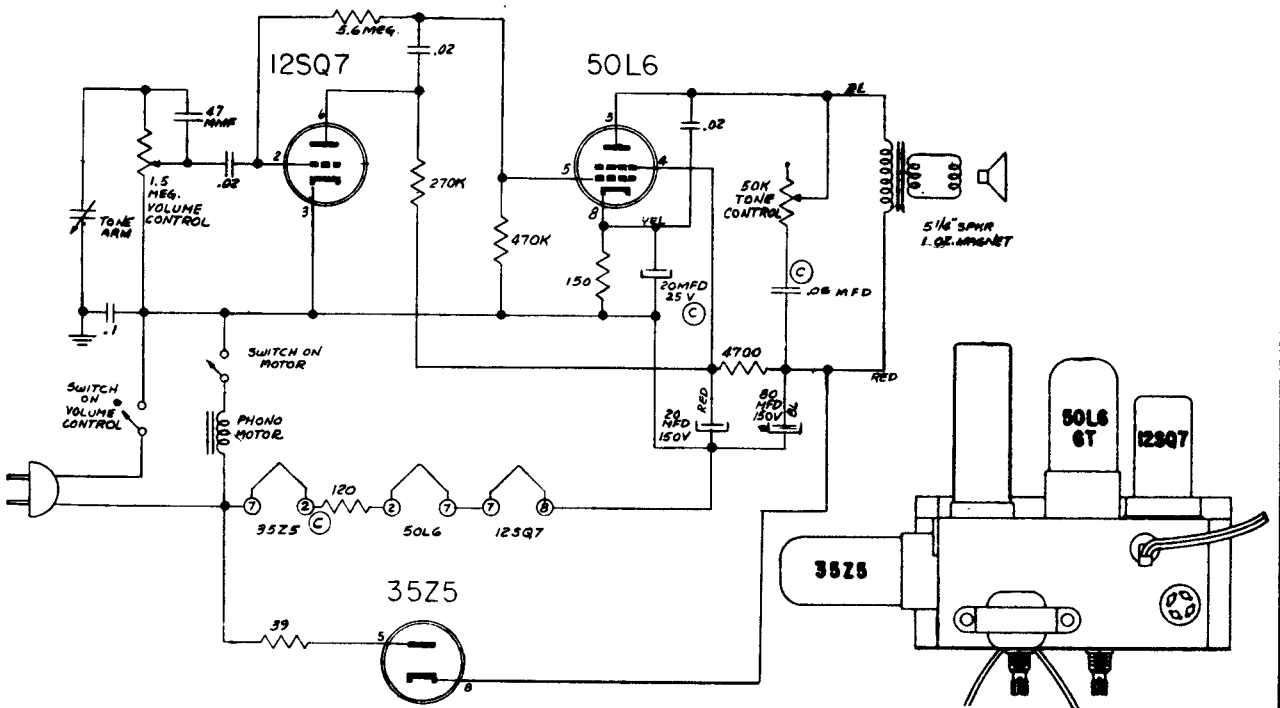

ZENITH RADIO MODELS Y832R & Y832E CHASSIS 8Y02

Alignment Information (See preceding page for circuit diagram)

DIAL CORD DRIVE

THIS SPRING ON BACK OF LARGE PULLEY

PULLEY SHOWN IN FULL COUNTERCLOCKWISE POSITION.

1 1/2 TURNS AROUND PULLEY AND ONE TURN AROUND RIVET.

Correct alignment can only be made if the following procedure is followed:

—A vacuum tube voltmeter with an isolation resistor of 2,000,000 ohms in series with the hot lead will serve for FM adjustments. This lead should be shielded.

—An AC output meter connected across the primary or secondary of the output transformer will be satisfactory for all AM adjustments.

—The signal generator output should be kept just high enough to get an indication on the meter.

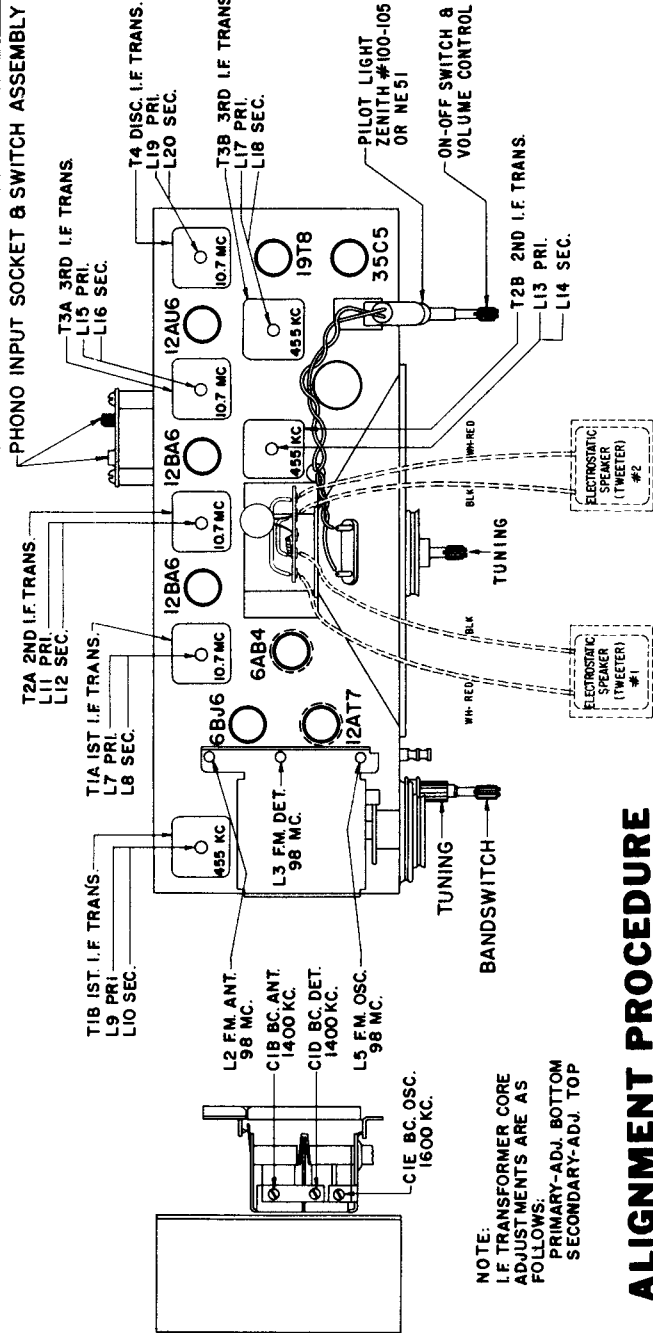

NOTE:
I.F. TRANSFORMER CORE ADJUSTMENTS ARE AS FOLLOWS:
PRIMARY-ADJ. BOTTOM
SECONDARY-ADJ. TOP

ALIGNMENT PROCEDURE

OPERATION	CONNECT OSCILLATOR TO	DUMMY ANTENNA	INPUT SIGNAL FREQUENCY	BAND	SET DIAL TO	ADJ. TRIMMERS	PURPOSE
1	Pin 7 12A7 Converter	.05 Mfd.	455 Kc. Modulated	BC	600 Kc	L-9, 10, 13, 14, 17 and 18.	Align I.F. channel for maximum output
2	2 turns loosely coupled to wavemagnet		1600 Kc. Modulated	BC	1600 Kc	C1E	Set Oscillator to dial scale
3	2 turns loosely coupled to wavemagnet		1400 Kc. Modulated	BC	1400 Kc	C1D and C1B	Align det. and ant. stages
4	IMPORTANT: Before attempting to align the FM portion of this receiver, the Band Switch must be in FM POSITION.						
5 (a)	Pin 1 (grid) on 12A6J6 limiter	.05 Mfd.	10.7 Mc. Unmodulated	FM		L19 coil slug Primary discr.	Align primary of discriminator for maximum reading
6 (b)	Pin 1 (grid) on 12A6J6 limiter	.05 Mfd.	10.7 Mc. Unmodulated	FM		L20 coil slug sec. of discr.	Adjust secondary of discriminator for zero reading
7 (c)	Pin 1 (grid) on 12BA6 2nd. IF.	.05 Mfd.	10.7 Mc. Unmodulated	FM		L15 and L16 Pri. and Sec. of 3rd IF transformer	Align 3rd. IF transformer for maximum reading
8 (c)	Pin 1 (grid) on 12BA6 1st. IF.	.05 Mfd.	10.7 Mc. Unmodulated	FM		L11 and L12 Pri. and Sec. of 2nd IF transformer	Align 2nd. IF transformer for maximum reading
9 (c)	Pin 7 (grid) on 12A7T7 converter tube socket	.05 Mfd.	10.7 Mc. Unmodulated	FM		L7 and L8 Pri. and Sec. of 1st IF transformer	Align 1st. IF transformer for maximum reading
10 (c)	REPEAT STEPS 7, 8 AND 9						
11 (c)(d)	Antenna Post F (Remove line ant.)	270 Ohms	98 Mc. Unmodulated	FM	98 Mc.	L5 Osc. Coil Slug	Set Oscillator to dial scale
12 (c)(d)		270 Ohms	98 Mc. Unmodulated	FM	98 Mc.	L3 and L2 Det. and RF coil Slugs	Align det. and ant. stages to maximum reading

ZENITH RADIO CORPORATION
MODEL T545 CHASSIS 5T04

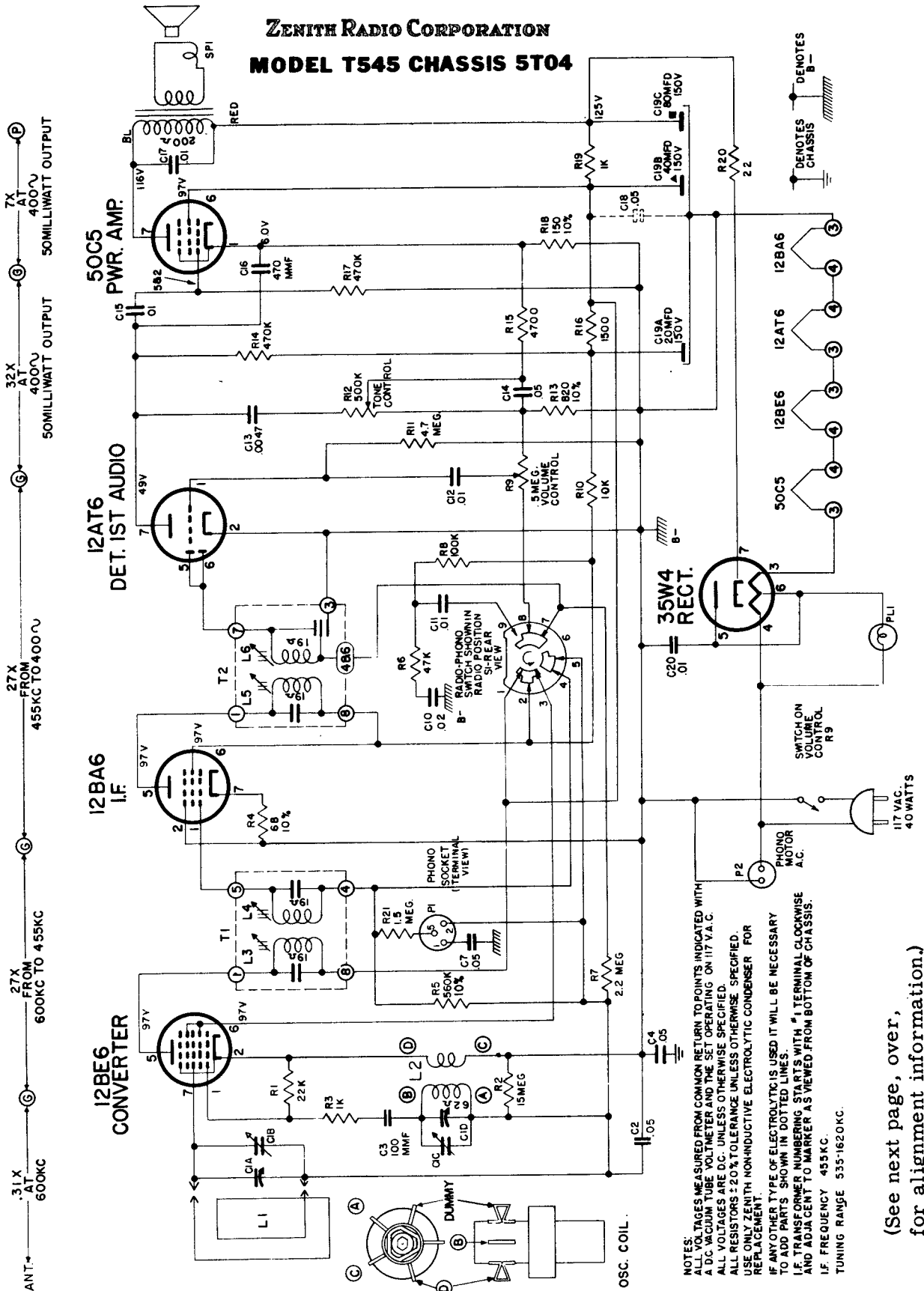

NOTES:
ALL VOLTAGES MEASURED FROM COMMON RETURN TO POINTS INDICATED WITH A DC VACUUM TUBE VOLTMETER AND THE SET OPERATING ON 117 V.A.C.
ALL VOLTAGES ARE DC. UNLESS OTHERWISE SPECIFIED.
ALL RESISTORS ±20% TOLERANCE UNLESS OTHERWISE SPECIFIED.
USE ONLY ZENITH NON-INDUCTIVE ELECTROLYTIC CONDENSER FOR REPLACEMENT.
IF ANY OTHER TYPE OF ELECTROLYTIC IS USED IT WILL BE NECESSARY TO ADD PARTS SHOWN IN DOTTED LINES.
I.F. TRANSFORMER NUMBERING STARTS WITH #1 TERMINAL CLOCKWISE AND ADJACENT TO MARKER AS VIEWED FROM BOTTOM OF CHASSIS.
I.F. FREQUENCY 455 KC.
TUNING RANGE 535-1620 KC.

(See next page, over,
for alignment information.)

VOLUME R-16, MOST-OFTEN-NEEDED 1956 RADIO SERVICING INFORMATION

ZENITH Model T545, Chassis 5T04, Alignment Procedure (Continued)

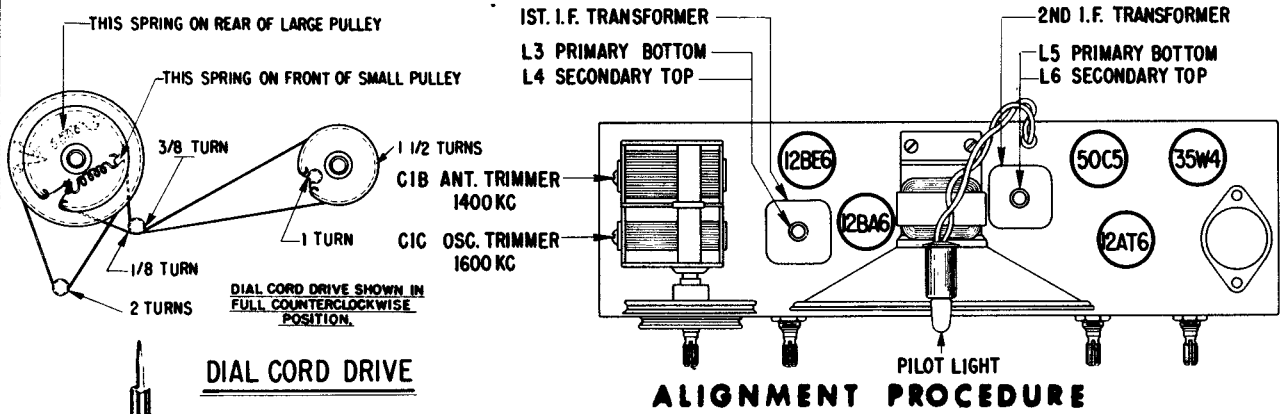

OPERATION	CONNECT OSCILLATOR TO	DUMMY ANTENNA	INPUT SIG. FREQUENCY	SET DIAL AT	TRIMMERS	PURPOSE
1	Converter Grid	.5 Mfd.	455 Kc.	600 Kc.	L3, 4, 5, 6	For I. F. Alignment
2	One Turn Loop Coupled Loosely to Wave Magnet	--	1600 Kc.	1600 Kc.	C1C	Set Oscillator to Dial Scale.
3		--	1400 Kc.	1400 Kc.	C1B	Align Antenna Stage

ZENITH Models T600, -L, Chassis 6T40, 6T41, Alignment Procedure

ZENITH MODELS T600, -L, CHASSIS 6T40, 6T41, ALIGNMENT DATA

OPER.	CONNECT OSCILLATOR TO DUMMY ANTENNA	INPUT SIGNAL FREQ.	BAND	SET DIAL AT	TRIMMERS	PURPOSE
1	Positive lead of signal generator to converter grid through a .1 Mfd. condenser & negative lead to negative filament of 1L6 tube.	455 Kc	BC	600 Kc	L 6,7,8,9	Align I.F.
2	One turn loop coupled loosely to broadcast wavemagnet	1600 Kc	BC	1600 Kc	C3F	Set oscillator to scale
3		1400 Kc	BC	1400 Kc	C3D	Alignment of BC Det.
4		1400 Kc	BC	1400 Kc	C3B	Alignment of BC ant.
5*		600 Kc	BC	600 Kc	Rock C16	Alignm't of BC at 600 Kc
6		7.8 Mc	4-8 Mc	7.8 Mc	C38A,C33A,C29A	
7*		4.2 Mc	4-8 Mc	4.2 Mc	Rock L23B	
8		REPEAT OPERATIONS 6 & 7				
9		3.9 Mc	2-4 Mc	3.9 Mc	C38B,C33B,C29B	
10*		2.1	2-4 Mc	2.1 Mc	Rock L24B	
11		REPEAT OPERATIONS 9 & 10				
12		17.8 Mc	16 Meters	17.8 Mc	L25,L19,L13	
13*		15.2	19 Meters	15.2	L26,L20,L14	
14		11.8 Mc	25 Meters	11.8	L27,L21,L15	
15*		9.6 Mc	31 Meters	9.6 Mc	L28,L22,L16	

* NOTE: Rock Tuning Condenser When Making Alignment Under Operations 5, 7, 10, 12, 13, 14 & 15.

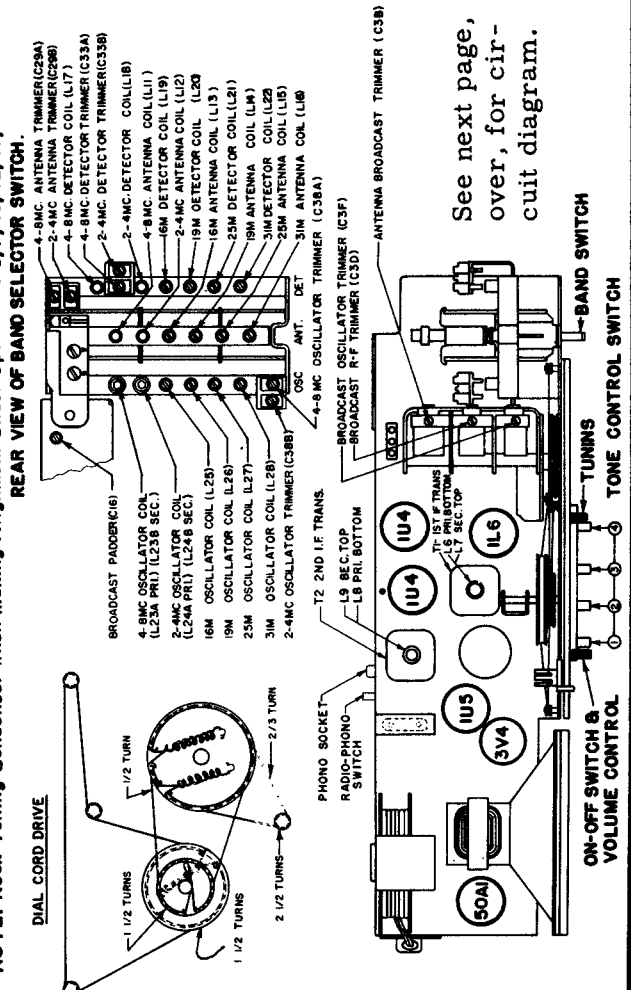

ZENITH RADIO CORPORATION

Models T600, -L, Chassis 6T40, 6T41
(Alignment data on preceding page)

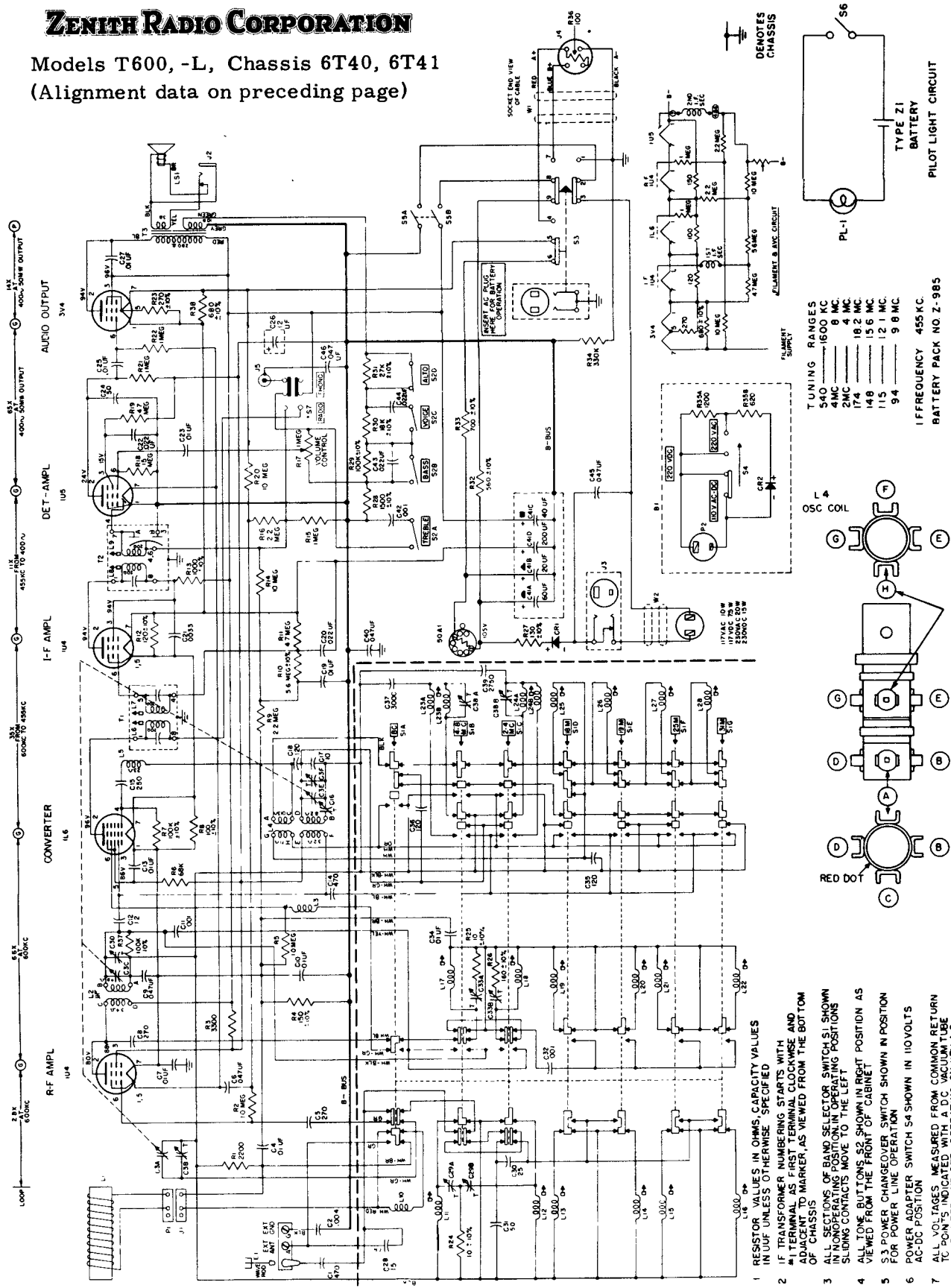

TUNING RANGES

540	1600 KC
4 MC	8 MC
2 MC	4 MC
174	18.2 MC
148	15.6 MC
115	12.1 MC
9.4	9.8 MC

IFF FREQUENCY 455 KC
BATTERY PACK NO. Z-985

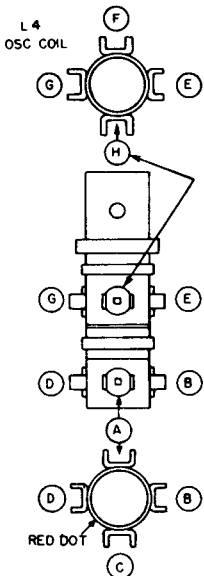

- 1 RESISTOR VALUES IN OHMS, CAPACITY VALUES IN UUF UNLESS OTHERWISE SPECIFIED
- 2 IF TRANSFORMER NUMBERING STARTS WITH #1 TERMINAL AS FIRST TERMINAL CLOCKWISE AND ADJACENT TO MARKER, AS VIEWED FROM THE BOTTOM OF CHASSIS
- 3 ALL SECTIONS OF BAND SELECTOR SWITCH S1 SHOWN IN NON-OPERATING POSITION IN OPERATING POSITIONS SLIDING CONTACTS MOVE TO THE LEFT
- 4 ALL TONE BUTTONS S2 SHOWN IN RIGHT POSITION AS VIEWED FROM THE FRONT OF CABINET
- 5 S3 POWER CHANGEOVER SWITCH SHOWN IN POSITION FOR POWER LINE OPERATION
- 6 POWER ADAPTER SWITCH S4 SHOWN IN 110 VOLTS AC-DC POSITION
- 7 ALL VOLTAGES MEASURED FROM COMMON RETURN POINTS INDICATED WITH A DC VACUUM TUBE VOLTMETER AND SET OPERATING ON 117 V AC

VOLUME R-16, MOST-OFTEN-NEEDED 1956 RADIO SERVICING INFORMATION

Index

Under each manufacturer's name are listed that make chassis and models in numerical order, at left. The corresponding page number at right of each listing refers to the first page of each section dealing with such material.

Admiral Corp.	CBS, Continued	Dodge (Auto)	General-Elect.	Motorola, Cont.
4D18D 3	T202 17	842 91	895 39	46HF1,-B 67
4D28D 3	T203 17	910 92	900 47	46HF1BD 67
4G2,-A 3	T204 17		900D 48	46HF1D 67
4G22D 3	216 17		902 47	55B1,-U 66
5A4 4	5110 18	Du Mont Labs.	902D 48	55J1 59
5A42 to 5A44 4	5220 19	RA-346 28	903 47	55J2 59
5A48 4	5440 20	RA-349 29	903D 48	55L1,-U 66
5B42 6			905 48	55L2,-U 66
5B43 6	Chevrolet		906 48	55L3,-U 66
5B48 6	CTA 5 72	Emerson Radio	907 48	55L4,-U 66
5M36D 5	CTA 6T 80	818B 30	911 49	55L5U 66
5M37D 5	CTM6 77	832B 31	911H 49	55M1,-U 66
5M56D, 5M57D 5	987086 159	834B 34	912 49	55M2,-U 66
5M66D 7	987187 164	835A 32	913 49	55M3,-U 66
5M67D 7	987364 159	836B 30	915 48	55M4U 66
5N3 5	987368 160	838 33	916 48	56B1A,AU 70
5W3 6		839B 34	920 50	56CC1 60
5W32 6	Crosley Corp.	841A 34	921 50	56CC2 60
5W33 6	JT3BK 23	842 35		56CD1 60
5W34 6	JT3GN 23	843 36	Hallcrafters	56CD2 60
5W38 6	JT3IY 23	120159B 30	3HFP-1 55	56CD3 60
5W39 6	JT3RD 23	120266B 31	3HFP-2 55	56CD4 60
6R2 7	JT4BK 23	120270B 34	51CLB 52	56CE1 60
	JT4GN 23	120271A 32	51C2B 52	56CJ1 60
Arvin	JT4IY 23	120274 33	5R70 51	56CJ2 60
RE-391 8	JT4RD 23	120291A 34	5R71 51	56CS1 60
RE-392 9	JC-6BK 24	120298 36	5R72CL 51	56CS2 60
RE-393 10	JC-6BN 24		5R73CL 51	56CS3 60
RE-397 11	JC-6TN 24	Ford (Auto)	TW-100 53	56CS4 60
950T 8	JC-6WE 24	FEF-18805B 95	TW-101 53	56H1 58
951T 8	JC-8BK 26	FDR-18805-B1 94	TW-102 53	56H2 58
956T 9	JC-8BN 26	FDR-18806F 96	TW-200 54	56H3 58
957T 10	JC-8TN 26			56H4 58
958T 11	JC-8WE 26			56L1A,AU 70
	JM-8BG 27	Gamble-Skogmo		56L2A,AU 70
Buick	JM-8BK 27	RA33-8115A 37	Hudson (Auto)	56L3A,AU 70
981707 153	JM-8BN 27	RAI-9245B 38	4389027 76	56L4A,AU 70
981708 154	JM-8GN 27	RAI-9246B 38	8990378 73	56M1A,AU 70
	JM-8MN 27		Montgomery-	56M2A,AU 70
Capehart	JM-8WE 27	General-Elect.	Ward	56M3A,AU 70
2C56 12	31T 22	453 39	GSL-1581A 56	56R1 58
2P56 13	T-31BK 22	465 40	GSL-1582A 56	56R2 58
46TP56B,M 15	T-31CU 22	466 40	WG-1635A 57	56R3 58
52PH56B,M 16	T-31GN 22	467 40	WG-1636A 57	56R4 58
53PH56B,F 16	T-31GY 22	470 41	GSL-1650A 56	56RF1 69
53PH56M 16	T-31IY 22	471 41	GSL-1651A 56	56RF2 69
75C56 14	T-31RD 22	472 41		56T1 65
CR-202 12	R100 23	475 42	Motorola, Inc.	56W1,-B 63
CR-218 13	R101 23	476 42	5M 74	56X1 63
CA-239 15	R102 27	477 42	5M-12 74	56X2 63
CA-241 16	R103 24	480 43	CTA 5 72	56X3 63
CR-242 14	R104 26	665 44	HN5AC-8 76	66C1 61
CA-251 16		666 44	6M 74	66C2 61
	Delco, see	667 44	6M-12 74	66HF1,-B 62
CBS-Columbia	United Motors	670 45	6MA 73	66HF1GM 62
4P1 19		671 45	6TAS8 78	66L1 71
4P2 18	DeSoto (Auto)	672 45	CTA6T 80	66L2 71
5C4 20	843 91	673 45	CTM6 77	66MF 94
T200 17	911 92	675 46	R6MA 84	66X1 64
T201 17		676 46	36F1,-C 68	66X2 64
			36F1G 68	

VOLUME R-16, MOST-OFTEN-NEEDED 1956 RADIO SERVICING INFORMATION

Motorola, Cont.

69MF	96
69MS	95
ST-162	98
396	82
396-12	82
HS-431	58
HS-454	59
HS-457	60
HS-458	61
HS-470	66
HS-472	66
HS-475	62
HS-476	63
HS-477	63
HS-478	64
HS-483	65
HS-486	66
HS-487	58
HS-490	60
HS-495	67
HS-496	68
HS-497	69
HS-499	60
HS-508	66
HS-509	66
HS-510	66
HS-512,-A	70
HS-513,-A	70
HS-514,-A	70
HS-515	71
555	85
555-12	85
556	86
595	85
595-12	85
596	88
596-12	88
620	90
621	90
841	91
842	91
843	91
910	92
911	92
916	93
8990378	73

Nash (Auto)

8990378 73

Oldsmobile

983334 158
983336 156

Packard (Auto)

472046 151
472047 152
472048 152
480487 160
6480488 152
6480489 152
7266027 160
7266047 152
7266067 152

Packard-Bell

1ORP1 103

Philco Corp.

TPA-1	108
TPA-2	108
D-579	105
D-590	105
D-591	105
D-592	106
D-593	106
D-597	107
D-598	106
D-717	105
D-719	105
D-725	107
D-726	105
D-727	106
D-728	106
D-730	106
D-734	107
D-736	106
D-737	107
D-738	107

Plymouth, Auto

841 91

Pontiac (Auto)

988569 162

RCA Victor

TR-1A	125
6-B-4A	115
6-B-4B	115
6-B-5	115
6BX8A	116
6BX8B	116
6BY4A	120
6BY4B	120
6C5	123
6-EMP-1A	113
6-EMP-1B	113
6-EMP-2A	113
6-EMP-2B	113
6-EMP-3A	113
6-EMP-3B	113
6-ES-5	114
6-EY-1	109
6-EY-2	109
6-EY-15	110
6-HFT-1	125
6-HF-4	111
6-HF-5	110
6-RD-3	112
6X5	122
6X7	117
6XD5	118
6XY5A	119
6XY5B	119
7BT9J	123
7BT1OK	121
7C6	123
7-EY-1	113
7-EY-2HH	114
7-EY-2JJ	114
RS-136J	109
RS-138S	109
RS-138U	110
RS-146C	111
RS-150	110

RCA, Continued

RS-150B	112
RS-152	113
RS-152A	113
RS-153	113
RS-155	113
RS-155A	114
RS-157	114
RP-199	126
RC-1098B	115
RC-1126A	116
RC-1128B	117
RC-1146A	118
RC-1152-	119
RC-1153,A	120
RC-1156	121
RC-1157	122
RC-1157A	123
RC-1159	124

Raytheon

4D16-A	131
4RT1	132
6RT1	133
8RT1	134
8TP1	134
8TP2	134
8TP3	134
8TP4	134
C-50B	131
C-51W	131
C-52R	131
T-100-1	132
T-100-2	132
T-100-3	132
T-100-4	132
T-100-5	132
T-150-1	133
T-150-2	133
T-150-3	133
T-150-4	133
T-150-5	133

Sears Roebuck

6020	135
6021	135
6025	135
6026	135
6056A	136
6057A	136
132.09000	135
528.40400	135
528.40500	136

Sentinel Radio

1U-360	138
1U-363	139
1U-364	140
359P	137
IU-365	141
IU-367	142
IU-368	142

Studebaker

AC-2745	149
AC-2746	150
AC-2747	149
AC-2748	150

Sylvania Elec.

1-607-1,2	143
1-607-3	143
1-607-4	145
1-610-1	146
1-611-1	146
515	143
519	143
1102	145
3201	146
3302	146
5151	143

Trav-ler

6514	148
6515	148
9064	148

Truetone, see Western Auto

United Motors

AC-2745	149
AC-2746	150
AC-2747	149
AC-2748	150
472046	151
472047	152
472048	152
480487	160
981707	153
981708	154
983334	158
983336	156
987086	159
987187	164
987364	159
987368	160
988569	162
6480488	152
6480489	152
7266027	160
7266047	152
7266067	152

Western Auto

D-2552A	165
D-2553A	165
D-3500A	166

Westinghouse

H-511P4	168
H-512P4	168
H-523T4	169
H-524T4	169
H-525T4	169
H-536T6	167
H-538T4	169
H-539T4	169
H-540T4	169
H-541T5	170
H-542T5	170
H-543T5	170
H-544T5	170
H-545T5	170
H-546T5	170

Westinghouse+

H-547T5	171
H-548T5	171
H-549T5	171
H-550T5	171
V-2189-7	167
V-2237-2	168
V-2239-1	169
V-2239-2	169
V-2259-1	170
V-2261-1	171

Zenith Radio

3X01	172
3Y02	173
3Y03	174
3Y04	175
3Y05	176
5T03	179
5T04	188
5T06	180
5X06	181
5X07	181
5Y01	178
6T40	190
6T41	190
YP6B	185
YP6F	185
7T02	182
7T04	182
7X03	182
7XT40	184
7Y02	182
7Y03	182
7Y04	182
8Y02	186
YP8L	185
HFY10L,Y	175
HFY12E,R	175
HFX14,-E	174
HFY15E,R	176
HFY17E,R	173
T404F,L,P	177
T404V,-W	177
T405F,L,P	177
T405V,-W	177
500	184
Y513F,-G	178
Y513R	178
Y513W	178
X514V,-W	181
519F,-G	181
519R,-W	181
T521F,-G	179
T521R,W,Y	179
T522F,-G	180
T522R,V,W	180
T545	188
T600,-L	190
T723	182
Y723,-G	182
Y723R,-W	182
T724	182
Y724G,R,W	182
X733G,R,Y	182
Y733G,R,Y	182
Y832E,-R	186
X2280	172