

Engineering Data

Stromberg-Carlson No. 235 Radio Receivers

STROMBERG-CARLSON TELEPHONE MANUFACTURING COMPANY
Rochester, New York

ELECTRICAL SPECIFICATIONS

Type of Circuit.....	Superheterodyne with A. F. C. Electric Tuning
Tuning Ranges.....	A—530 to 1700 Kc.; B-1700 to 5600 Kc.; C-5600 to 18,000 Kc.
Number and Type of Tubes.....	1 No. 6A8, 1 No. 6J5, 1 No. 6K7, 1 No. 6H6, 1 No. 6B8, 1 No. 6F6, 1 No. 6U5, 1 No. 5Y4G
Voltage Rating.....	105 to 125 Volts
Frequency Rating.....	25 to 60 Cycles and 50 to 60 Cycles
Input Power Rating.....	70 Watts

APPARATUS SPECIFICATIONS

No. 235-H Receiver.....	50 to 60 Cycles; P-28534 Chassis; P-26171 Loud Speaker
No. 235-HB Receiver.....	25 to 60 Cycles; P-28535 Chassis; P-26171 Loud Speaker
No. 235-L Receiver.....	50 to 60 Cycles; P-28534 Chassis; P-27375 Loud Speaker
No. 235-LB Receiver.....	25 to 60 Cycles; P-28535 Chassis; P-27375 Loud Speaker

CIRCUIT DESCRIPTION

The Stromberg-Carlson No. 235 Radio Receivers are eight tube, "Electric Tuning", superheterodyne receivers and have three tuning ranges. Either "Manual" or "Electric" tuning is easily obtainable by simply rotating the "Manual-Electric" tuning control knob to the desired position; when the Manual-Electric tuning control knob is set so that the arrow on the knob points in the direction of the word "Manual", the tuning dial of the receiver is illuminated and when the arrow on this control knob points in the direction of the word "Electric" the call letters of the six stations which are set-up for electric tuning become illuminated. When it is desired to tune in stations located in either the Medium Wave or Short-Wave ranges, the electric tuning arrangement is made inoperative. The electric tuning circuit is arranged so that six favorite stations located in the Standard Broadcast range may be set-up for instantaneous selection by means of the push-buttons (Local and other stations that give the best daytime and evening service should be selected). To properly set-up the electric tuning arrangement for the six favorite broadcast stations, read the section, "Instructions for Setting Up the Electric Tuning Arrangement" appearing on page 6 of these instructions. When manually tuning these receivers or when setting up the six desired stations for electric tuning, resonance with a signal is indicated by means of the tuning indicator tube which operates on the cathode-ray principle. The strength of a received signal may be determined by observing the size of the aperture appearing on the target of the tuning indicating tube, the stronger a received signal the greater the reduction in the size of the aperture.

In order to obtain maximum performance on the Standard Broadcast Range ("A" Range) of these receivers, a "signal admission control switch" is provided. This control is located on the inside rear flange of the

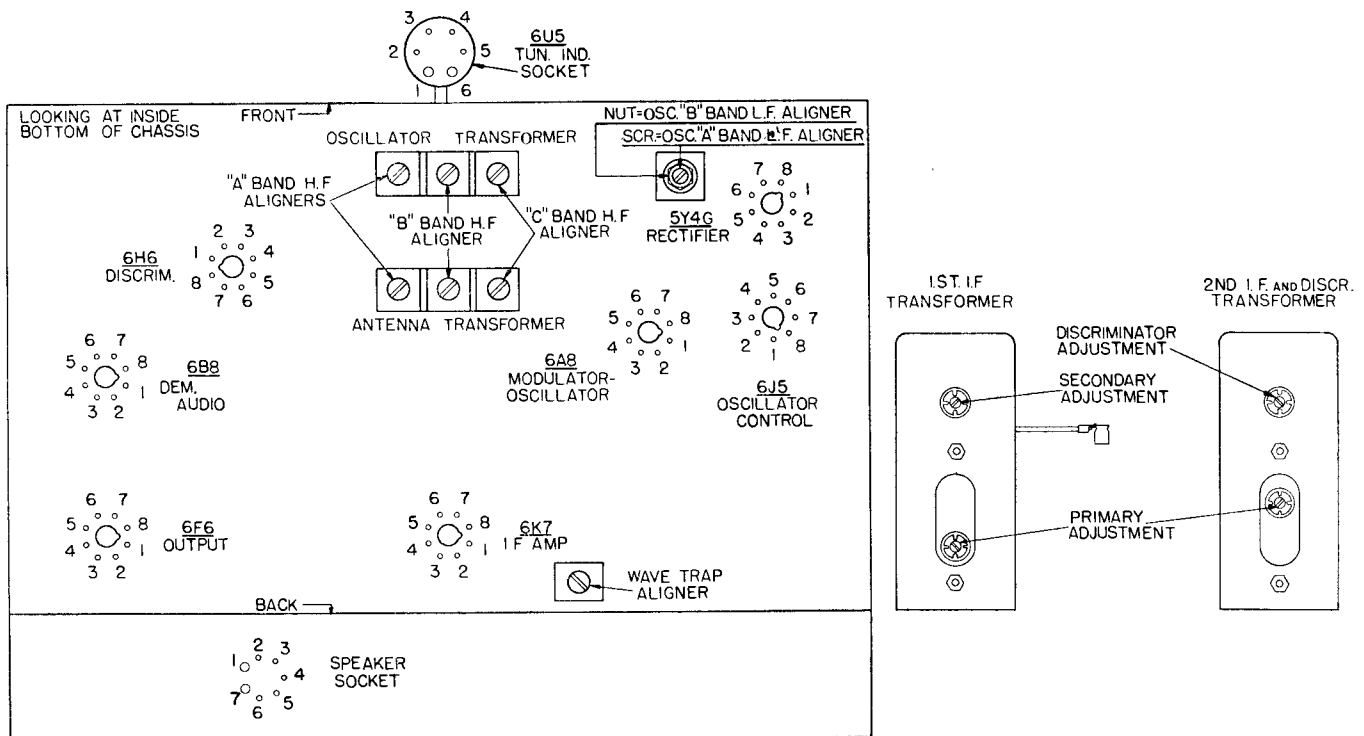

Fig. 1. Terminal Layout for Voltage Measurement Chart and Location of the Aligning Adjustments for the R. F., I. F. and Discriminator Circuits.

chassis base, and has a slotted shaft which protrudes through the base so that it may be adjusted by the use of a screwdriver. When either the "B" or "C" ranges are in operation, this signal admission control is automatically cut out of the circuit, allowing the receiver to function at its maximum sensitivity on these two ranges. When operating in the Standard Broadcast Range, maximum sensitivity is obtained when the slotted shaft of this control is rotated to its maximum counter-clockwise position. To properly set this signal admission control, place the receiver in operation and then adjust this control so that clearest reception is obtained. The control should remain in this position. Do not readjust this control for each frequency. The above adjustment should be made in the evening if best results are to be obtained.

The volume control circuit in these receivers is arranged to give balanced reproduction at any setting of the volume control by means of a low level bass frequency compensating network. A metal guard frame is also furnished on these receivers to prevent damage to the chassis components and also to facilitate ease of servicing should this become necessary.

The various tubes are used in these receivers as follows: The 6A8 tube functions as both Oscillator and Modulator tube. The No. 6J5 tube is used in the Oscillator Control Circuit for Automatic Frequency Control. The No. 6K7 tube is used in the I. F. Amplifier, and the No. 6H6 tube is used both in the Discriminator section of the Automatic Frequency Control Circuit and also as the Automatic Volume Control tube. The No. 6B8 tube is used for both Demodulator and Audio Amplifier tube. The No. 6F6 tube is used in the Audio Power Output Stage and the No. 6U5 tube is used for indicating resonance in the tuning indicator system. The No. 5Y4G tube is the Rectifier tube of the Power Supply Unit.

NORMAL VOLTAGE READINGS

The various values of voltages listed in the following table are obtained by measuring between the various tube socket contacts and the chassis base, with the tubes in their respective sockets. The receiver is, therefore, in operation when the measurements are made. Figure 1, shows the terminal layout of the sockets with the proper terminal numbers.

Voltages are given for a line voltage of 120 volts, and allowance should be made for differences when the line voltage is higher or lower. A meter having a resistance of 1000 ohms per volt should be used for measuring the D. C. voltages. Voltage values shown are those obtained on the lowest possible scale of a meter having the following ranges: 0-2.5, 0-10, 0-100, 0-250, 0-500, 0-1000 volts except when an asterisk appears after any given voltage value in which the 250 volt scale was used.

Tube	Circuit	Cap	Terminals of Sockets								Heater Voltages Between Heater Terminals	
			1	2	3	4	5	6	7	8	Socket Terminal Numbers	Volts
6A8	Osc.—Mod.	0	0	0	+255	+76	—18	+160	<i>6.1</i>	+2	2-7	<i>6.1</i>
6J5	Osc. Control	—	0	0	+120	0	0	+160	<i>6.1</i>	+5.4	2-7	<i>6.1</i>
6K7	I. F. Amp.	0	0	0	+255	+76	+2.4	+240	<i>6.1</i>	+2.4	2-7	<i>6.1</i>
6H6	Discriminator— A. V. C.	—	0	0	0	0	0	0	<i>6.1</i>	0	2-7	<i>6.1</i>
6B8	Demodulator— Audio Amp.	0	0	0	+48*	0	0	+20*	<i>6.1</i>	+3.4	2-7	<i>6.1</i>
6F6	Audio Output	—	0	0	+245	+255	0	+240	<i>6.1</i>	+18	2-7	<i>6.1</i>
6U5	Tuning Indicator	—	<i>6.1</i>	+8*	0	+255	+3.4	0	—	—	1-6	<i>6.1</i>
5Y4-G	Rectifier	—	0	0	338	0	338	0	+340	+340	7-8	<i>4.8</i>
Speaker Socket		—	+340	0	0	+340	+340	0	+300	—		

A. C. voltages are indicated by italics. Receiver tuned to 1000 Kc., no signal

ALIGNMENT DATA

All alignment adjustments are accurately made at the factory on these receivers, and ordinarily no readjustments are necessary. However, should it become necessary to make any readjustments, the procedure given in these instructions should be carefully followed. The preferred method of aligning these receivers is by the use of a suitable cathode ray oscillograph and frequency modulator unit in conjunction with the standard signal generator.

To accurately align circuits in these receivers, it is necessary to use a high grade signal generator capable of being modulated 30% and having an output voltage of at least 100,000 microvolts; it will also be necessary to have this output voltage controlled so that only a few microvolts may be fed into the receiver. In conjunction with the signal generator, a sensitive output meter should be used for determining the maximum signal voltage developed across the voice coil of the loud speaker. In addition to this equipment, it will be necessary when making a final adjustment of the "Discriminator" tuned circuit to use a milliammeter having a range of 0 to 10 milliamperes connected in series with the cathode of the 6J5 oscillator control tube by means of an adaptor plug inserted between the tube and its socket. The leads to the meter should not be longer than 15", and should be shunted at the socket connections by a capacitor of not less than 0.25 Mfd.

In order to make the aligning adjustments in an easy and satisfactory manner, it is recommended that the Stromberg-Carlson P-27657 and P-27658 aligning tools be used.

Before proceeding with the alignment of any circuits in these receivers, except when specifically directed, be sure that the "Signal Admission Control" is set for the maximum sensitivity position, and that the "Manual-Electric" control knob is set to the "Off" position. The "Off-On-Tone" control should also be set for the "Normal" position. In making any alignment adjustments always adjust the test oscillator's output voltage to the minimum value where a good alignment may still be obtained, except when specifically directed in these instructions. Figures Nos. 1 and 2, show the location of all the aligning capacitors or adjustments for this receiver. It will not be necessary to remove the chassis in this receiver from its cabinet in order to make any alignment adjustments. The alignment adjustments for the Intermediate Frequency circuits are accessible from the rear of the receiver, and the adjustments for the Radio Frequency circuits are accessible through apertures located in the bottom metal base plate of the chassis. These apertures are easily accessible through the bottom of the cabinet shelf. Never align any of these receivers without having the metal base plate fastened to the chassis base.

Dial Adjustment

Before aligning the circuits of these receivers, the tuning dial must be properly aligned to "track" with the gang tuning capacitor. To check whether the dial is set correctly with respect to the gang tuning capacitor, rotate the "Rapid Station Selector" knob in a clockwise direction so that the gang tuning capacitor is set to its maximum capacity position. Then, with the receiver turned "on", the illuminated dial indicator line should be exactly centered over the dial alignment lines (black lines) which are located at the extreme low frequency end of each scale on the dial. If these lines do not center over the illuminated dial indicator line, loosen the two set screws located on the hub of the dial. Then, rotate the dial so that these alignment lines are centered over the illuminated dial indicator line. The two set screws of the dial hub should then be securely tightened.

Intermediate Frequency Adjustments

The intermediate frequency used in these receivers is 465 kilocycles. Because of the necessity of obtaining the proper shape of resonance curve of these stages, it is recommended that unless it is absolutely essential, these I. F. adjustments be untouched. In the factory these adjustments are made using a visual system

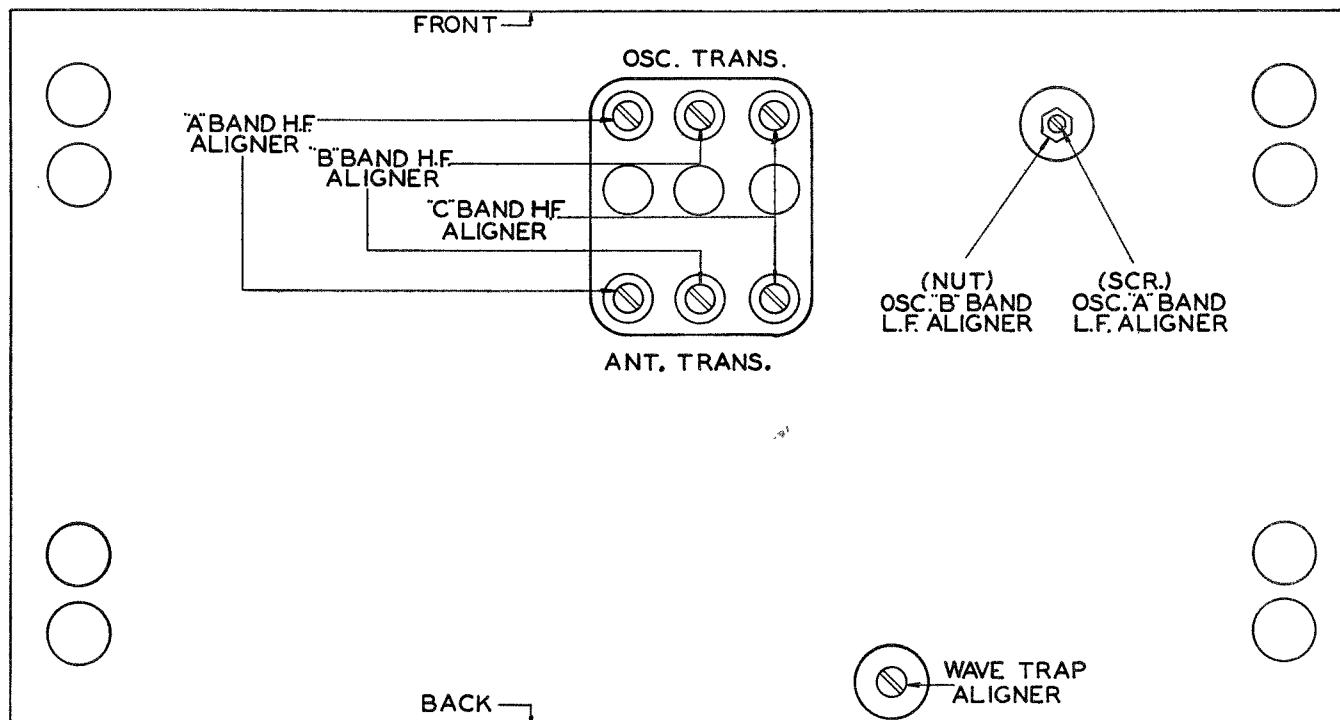

Fig. 2. View Through Chassis Mounting Shelf Showing Adjusting Screws for R. F. Aligning Capacitors.

which allows the operator to see the exact shape of the resonance curve. For this reason it is best to have these adjustments made at the factory. However, in the case where this cannot be done, the following procedure should be followed.

1. Operate the Range Switch of the receiver to the Standard Broadcast range position and set the tuning dial to its extreme low frequency position. Set the "Manual-Electric" control knob to the "Manual" position, and the "Off-On-Tone" control knob to its normal position.

CAUTION: Never attempt to align the R. F. or I. F. circuits of this receiver with the "Manual-Electric" control knob set at the "Electric" position unless specifically directed in the following paragraphs. Also, do not make any aligning adjustments of the R. F., I. F., or "Discriminator" circuits with the A. F. C. switch (which is located on rear of the chassis base) set at the "set-up" position.

2. Apply between the chassis base (or ground binding post) of the receiver and the grid of the No. 6A8 modulator-oscillator tube, a modulated signal of 465 kilocycles from the signal generator, using a 0.1

mfd. capacitor in series with the connection between the output terminal of the signal generator and the grid of the No. 6A8 tube. Do not remove the chassis grid lead connecting to this tube. The ground (or low side) terminal of the signal generator should be connected to either the chassis base or the ground binding post.

3. Now, noting from Fig. 1, the alignment adjustments for the First and Second I. F. transformers, align the I. F. circuits in the following order:

Adjust the Second I. F. transformer primary circuit for maximum output.

Adjust the First I. F. transformer primary circuit for maximum output.

Adjust the First I. F. transformer secondary circuit for maximum output.

Carefully make all of the above adjustments, watching carefully the output meter so that the peak reading is obtained for each adjustment. As each adjustment is made reduce the output of the test oscillator as required.

4. To adjust the Discriminator circuit proceed as follows:

Check the position of the "Manual-Electric" control knob which should be set to the "Manual" position.

CAUTION: Before adjusting this circuit be sure that the I. F. amplifier is tuned exactly to 465 kilocycles. With the signal generator still set at a frequency of 465 kilocycles, adjust the signal generator's output control so that a signal of 50,000 to 100,000 microvolts is fed into the No. 6A8 modulator-oscillator tube. Now, observe the reading of the milliammeter which is connected in series with the cathode of the No. 6J5 oscillator control tube, and rotate the "Manual-Electric" control knob to the "Electric" position, observing whether there is any difference in the reading of the milliammeter. When this circuit is correctly adjusted, there should be no difference in the reading of the milliammeter when the "Manual-Electric" control knob is rotated from the "Manual" to the "Electric" position. If there is any difference in the milliammeter reading while rotating this control knob from the "Manual" to the "Electric" position, and vice versa, adjust the "Discriminator" circuit by means of the screw adjustment located on the 2nd I. F.—Discriminator transformer until the meter reading has the same value regardless of whether the "Manual-Electric" control knob is rotated to the "Manual" or "Electric" position. When this condition is obtained, the Discriminator circuit is properly adjusted.

Radio Frequency Adjustments

The alignment of the radio frequency circuits in these receivers should be very carefully made and in the order specified.

When making any aligning adjustments of these circuits, the "Manual-Electric" control knob should be rotated to the "Manual" position, and the "Off-On-Tone" control knob should also be set for "Normal" operation.

Alignment of Short Wave Range (Also Referred to as "C" Band)

In aligning the radio frequency circuits for this range, replace the 0.1-microfarad capacitor which was placed in series with the test oscillator's output lead for the I. F. alignments, with a 400-ohm carbon type resistor. This lead should then be connected to the antenna binding post located on the rear of the receiver chassis. The ground terminal (or low side) of the test oscillator should be connected to the ground binding post on the receiver.

1. Operate the Range Switch on the receiver chassis to the "C" range position, and set the test oscillator's frequency and the receiver's tuning dial to 17 megacycles.
2. Adjust the oscillator's "C" band high frequency aligner for maximum output.
3. Adjust the antenna's "C" band high frequency aligner for maximum output, at the same time rotate the gang tuning capacitor back and forth through resonance until maximum output is obtained.

Alignment of Medium Wave Range (Also Referred to as "B" Band)

In aligning the radio frequency circuits for this range, use the same artificial antenna (400-ohm carbon type resistor) in series with the output terminal of the test oscillator as was used for aligning the short-wave range.

1. Operate the Range Switch on the receiver chassis to the "B" range position, and set the test oscillator's frequency and the receiver's tuning dial to 5 megacycles.
2. Adjust the oscillator's "B" band high frequency aligner for maximum output.
3. Adjust the antenna's "B" band high frequency aligner for maximum output, and at the same time rotate the gang tuning capacitor back and forth through resonance until maximum output is obtained.
4. Set the test oscillator's frequency and the receiver's tuning dial to 1.8 megacycles.
5. Adjust the oscillator's "B" band low frequency aligner (series aligner), and at the same time rotate the gang tuning capacitor back and forth through resonance until maximum output is obtained.
6. Reset both the test oscillator's frequency and the receiver's tuning dial to 5 megacycles and repeat operations Nos. 2 and 3.

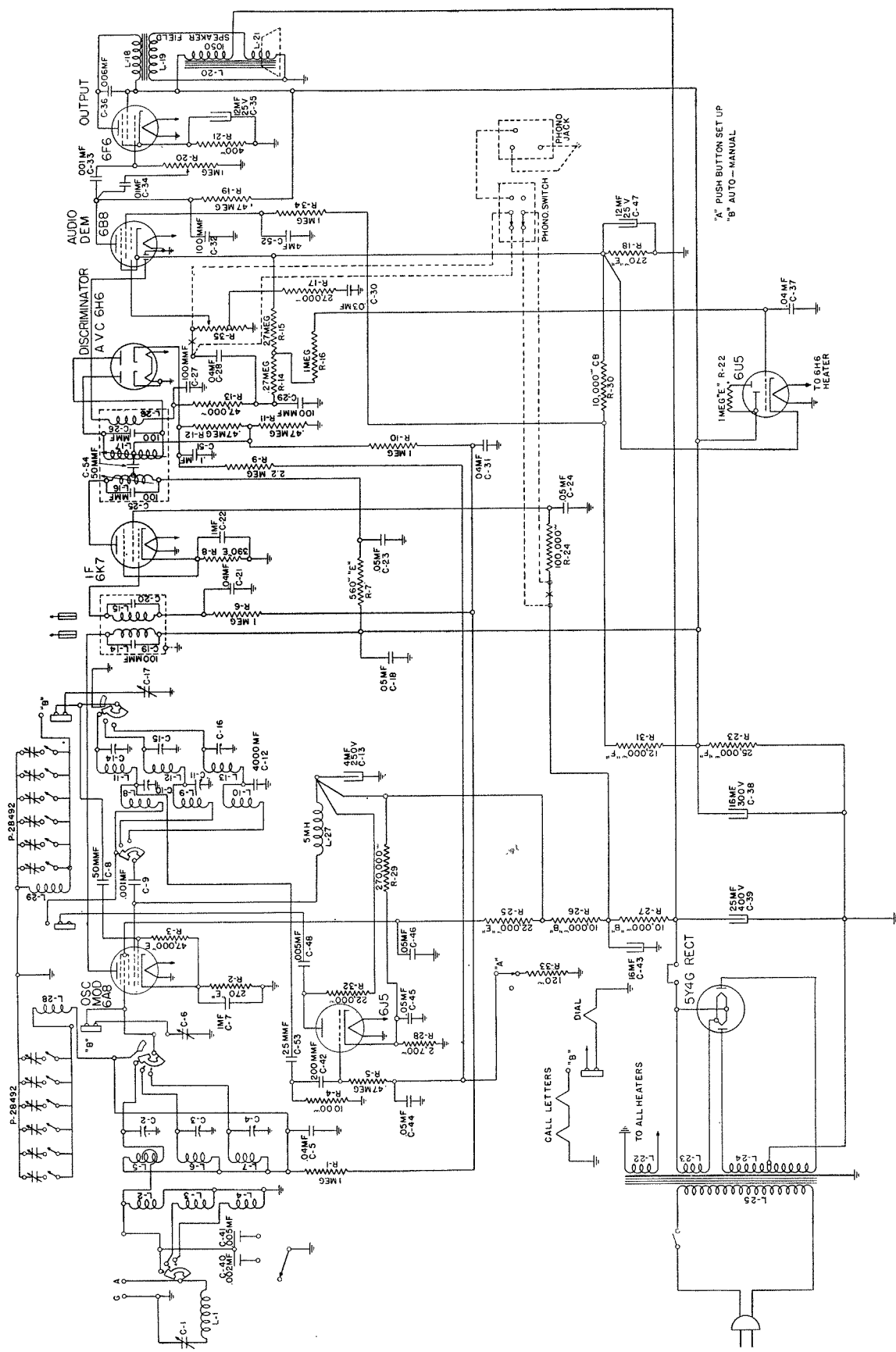

Fig. 3. Schematic Circuit of Receiver.

Alignment of Standard Broadcast Range (Also Referred to as "A" Band)

In aligning the radio frequency circuits for this range, replace the 400-ohm carbone type resistor in series with the test oscillator's output lead with a 200-micro-microfarad capacitor and align these circuits as follows:

1. Operate the Range Switch to the "A" range position and set the test oscillator's frequency and the receiver's tuning dial to 1.4 megacycles.
2. Adjust the oscillator's "A" band high frequency aligner for maximum output.
3. Adjust the antenna's "A" band high frequency aligner for maximum output.
4. Set the test oscillator's frequency and the receiver's tuning dial to 0.6 megacycles.
5. Adjust the oscillator's "A" band low frequency aligner (series aligner) for maximum output, and at the same time rotate the gang tuning capacitor slightly back and forth through resonance until maximum output is obtained.
6. Reset both the test oscillator's frequency and receiver's tuning dial to 1.4 megacycles and repeat operations Nos. 2 and 3.

Wave Trap Adjustment

In adjusting the wave trap circuit, the "Signal Admission Control" should be set for the most sensitive position (shaft rotated in the most counter-clockwise direction). Set the Range Switch of the receiver to the "A" range position, the tuning dial to 1000 kilocycles, and the "Manual-Electric" control knob to the "Manual" position. Connect a 200-micro-microfarad capacitor in series with the output terminal of the modulated test oscillator and the antenna binding post on the receiver, and the ground terminal of the test oscillator to the ground binding post on the receiver. Then, with the modulated test oscillator set at the frequency of the intermediate amplifier, 465 kilocycles, supply a fairly strong signal to the receiver and adjust the wave trap aligner until a minimum indication is obtained on the output meter.

PROCEDURE FOR OBTAINING REPRODUCTION FROM PHONOGRAPH RECORDS

In order to obtain reproduction of phonograph records in conjunction with the No. 235 Receiver, the following instructions should be followed.

To equip these receivers for phonograph operation, it will be necessary to purchase and install in the receiver a Stromberg-Carlson, P-28120 Switch Assembly. The rear of the chassis base of these receivers is already drilled for mounting this switch assembly. Complete instructions on how to install and operate this switch are furnished with each P-28120 Switch Assembly.

To obtain the best quality of phonograph reproduction when using an electric pick-up and phonograph unit with this receiver, a Stromberg-Carlson, No. 10 Record Player is recommended. This record player is equipped with a correctly designed single record playing motor unit, and uses a crystal type pick-up in conjunction with a specially equalized circuit.

If the Stromberg-Carlson No. 10 Record Player is not used and the electric pick-up to be used is of the high impedance type, it will be necessary to connect a low capacity shielded cable between the three-prong socket mounted in the P-28120 Switch Assembly and the pick-up. This shielded cable should be of the low capacity type, in order to prevent excessive cutting of high frequencies which is caused when a shielded cable having high capacity is used. The length of the shielded cable used should be kept as short as possible.

If a pick-up of the low impedance type is used, it will be necessary to connect a "matching transformer" between the three-prong socket mounted in the P-28120 Switch Assembly, and the pick-up. The transformer should be located as near to the receiver as possible, in which case it will not be necessary to use a shielded cable.

INSTRUCTIONS FOR SETTING UP ELECTRIC TUNING ARRANGEMENT

1. Before proceeding to set-up the stations for electric tuning, the radio receiver should be turned "on" for approximately twenty to thirty minutes.
2. Set the Range switch control knob to the proper position for the "Broadcast" range (arrow pointing in direction of "Cream" dot).
3. Remove the list of station letters from the P-28781 package assembly which is tacked inside of the cabinet.
4. Remove the two screws which hold the escutcheon plate to the front panel.
5. Remove from the escutcheon frame the strip of transparent material and the strip of paper on which the six stars are printed.
6. Remove the tuning indicator unit from its normal operating position.

IMPORTANT: Always use the tuning indicator unit when setting up stations for electric tuning, in order to determine when resonance with the desired station is obtained.

7. From the lists of stations, remove the call letters of the six stations which it is desired to set up for electric tuning. These six stations should preferably be selected and set-up in the daytime so that the best service will be obtained at all times.

CAUTION: Each button adjustment for electric tuning has assigned frequency limits. These limits are designated for each adjustment on the rear plate which covers the tuning adjustments and are visible

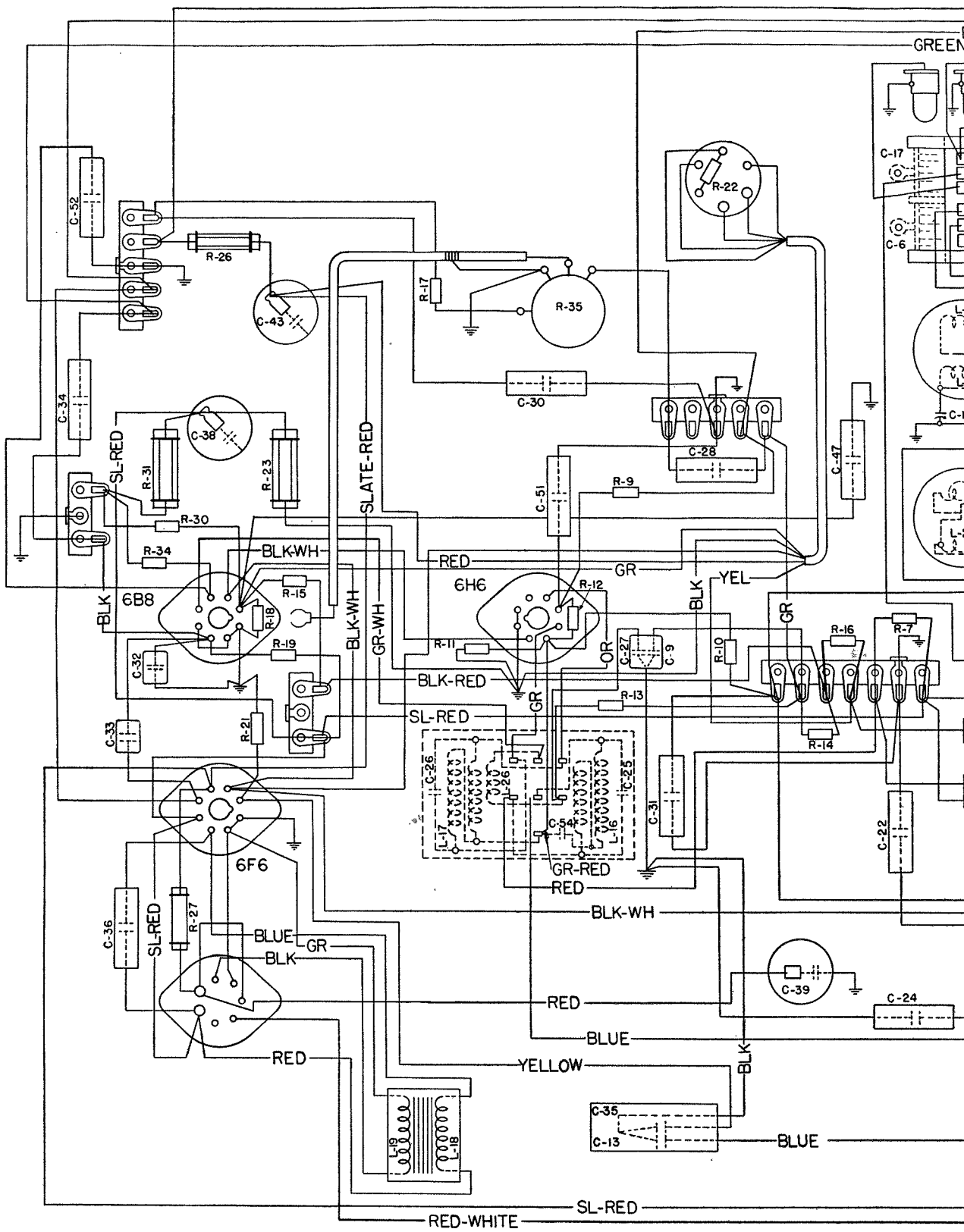

Fig. 4. Wiring Diagram,

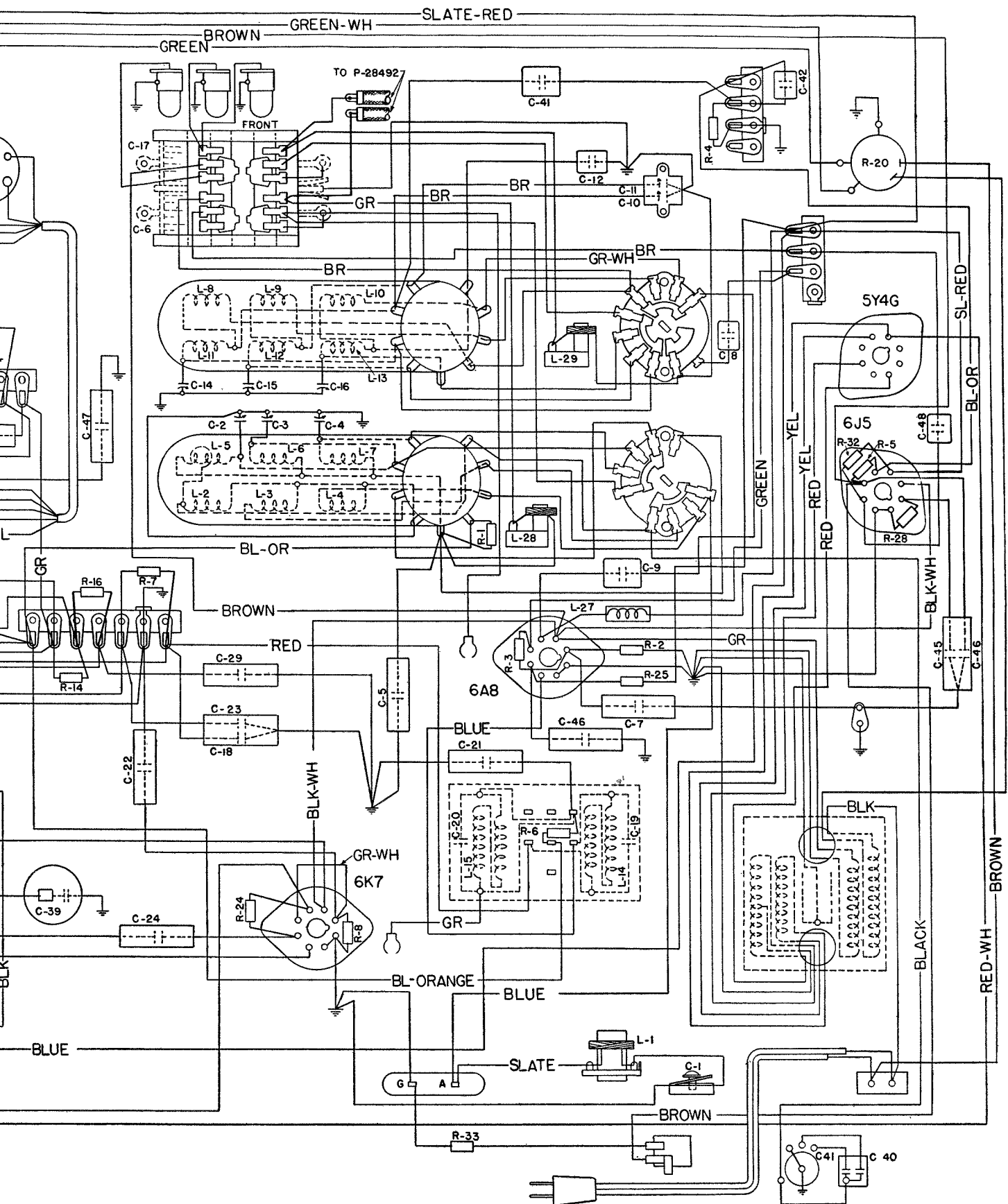

Fig. 4. Wiring Diagram, No. 235 Receiver.

when looking at the rear of the receiver. See Figure 5. The six stations should be selected so that the frequency of each station will be within the frequency limits assigned to one of the buttons.

It will be noted that the station letters are printed on partly cut squares to facilitate ease in removing the desired station letters. In setting up these six favorite stations, the following order should be followed: Looking at the front of the receiver, the call letters of the station having the highest frequency should appear in the farthest left-hand square of the escutcheon frame, and then in successive order according to frequency the call letters of the remaining stations should be inserted into the other frames; the call letters of the station having the lowest frequency being inserted in the farthest right-hand square of the escutcheon frame. After the six station call letters have been inserted into the escutcheon frame, the transparent strip should be replaced over the station call letters, and the escutcheon plate then fastened into position by means of the two screws. The tuning adjustments for the six favorite stations can now be made starting with the station having the highest frequency and proceeding as follows:

8. **IMPORTANT.** By the aid of a screwdriver, rotate the slotted shaft of the "A. F. C." switch, which is located on the rear of the chassis base, so that the slotted shaft points in the direction of the word, "Set-up" (maximum clockwise rotation). See Figure 5.
9. Rotate the knob marked "Manual-Electric" (located on the front panel of the receiver) so that the arrow points in the direction of the word "Manual" and tune the receiver in the conventional manner by means of the station selector knobs to the station having the highest frequency (of the six selected stations) and note carefully the program which it is broadcasting. Then rotate the knob marked "Manual-Electric" so that the arrow points in the direction of the word "Electric".
10. Push the farthest left-hand button (looking at the front of the receiver) which should be the button for the station having the highest frequency provided the frequency of the station is within the designated frequency limits of the tuning adjustments for this button. See Figure 5. Then, looking at the rear of the receiver, rotate the screw of the oscillator tuning adjustment which is designated 1560 to 1000 kilocycles to the position where the desired station is received. In order to check whether the program being received is from the desired station, simply rotate the "Manual-Electric" control to the "Manual" position, and with the receiver tuned in "Manually" to the desired station a quick check can be made; then, rotate the "Manual-Electric" control knob back to the "Electric" position. **Exact resonance with the desired station should be obtained by observing the tuning indicator.** When this adjustment has properly been made, the screw of the antenna tuning adjustment designated 1560 to 1000 kilocycles should be rotated to the position where maximum indication is again obtained on the tuning indicator tube. When these adjustments have been properly made the station having the highest frequency is correctly set-up for Electric Tuning by means of the push button.
11. Now proceed to set-up the remaining five stations in the same manner as mentioned in Paragraphs, 9 and 10 above, proceeding according to the frequency of the remaining stations.

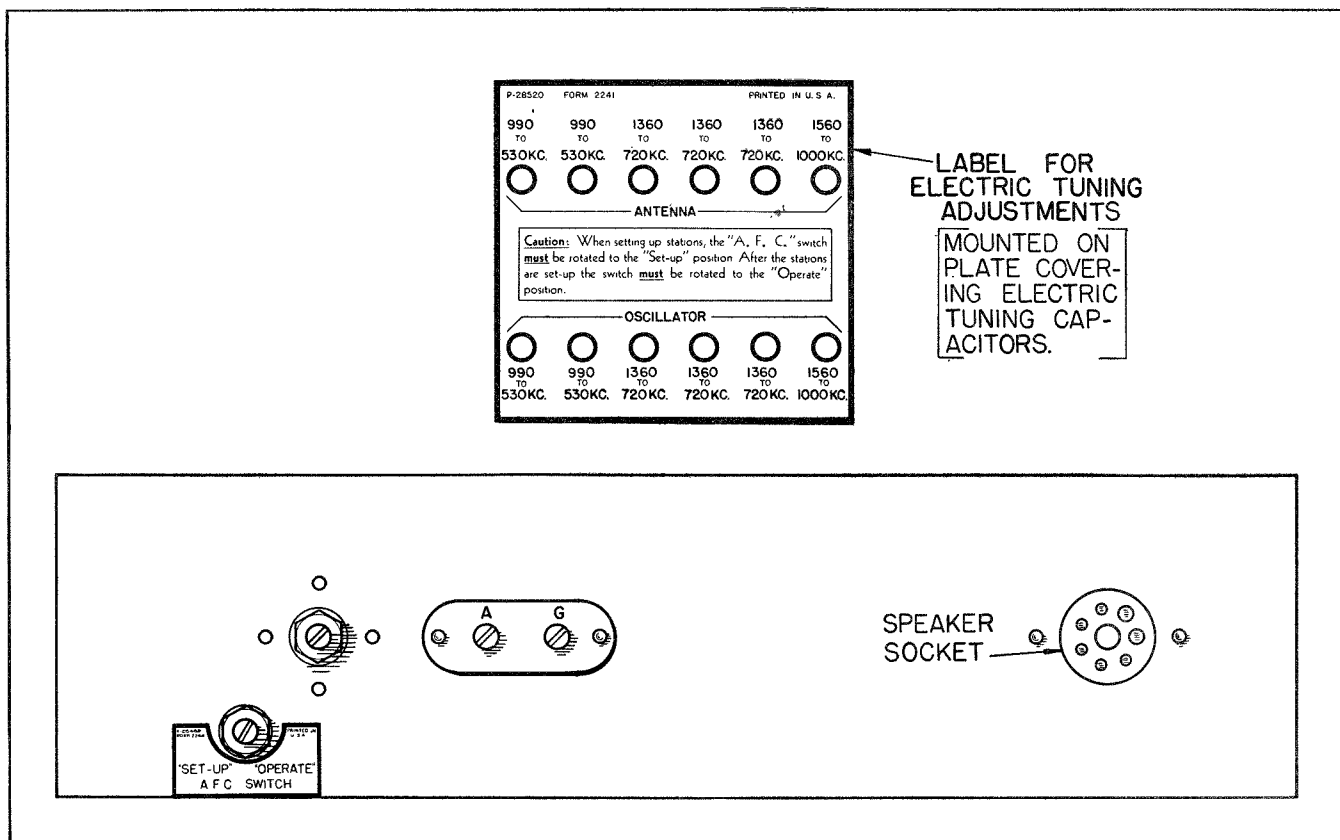

Fig. 5.

12. **IMPORTANT:** When all of the adjustments have properly been made for the six desired stations, the slotted shaft of the "A. F. C." switch, located on the rear of the chassis base, should be rotated so that the slotted shaft points in the direction of the word, "Operate" (maximum counter-clockwise rotation). With the electric tuning system in operation, the receiver will be automatically kept in tune with any one of the six favorite stations as long as the station is operating or provided it has no unusual fading characteristics. If a distant station which is very weak is set up in the electric tuning unit, it will be found that the automatic frequency control circuit will not hold this station if a strong signal is present in either adjacent channel. This same phenomenon will occur if two stations in adjacent channels are almost of equal signal strength with the weakest signal fading slightly; with this condition the strong signal will have a tendency to "pull in" when the receiver is tuned to the station which is slightly weaker and fading.
13. The tuning indicator unit should now be replaced in its proper operating position. Before placing this unit in its proper location, make sure that the tuning indicator tube is fully inserted into its accompanying socket.

REPLACEMENT PARTS

Piece Number	Schematic Circuit Designation	Part
18696	R26, R27	Resistor, Type "B", 10,000 Ohms
23517	.	Socket, 7 Prong
24166	C53	Capacitor, Type "O", 25 Mmfd.
24268	.	Cord (Power Supply)
24402	C7, C22, C51	Capacitor, .1 Mfd.
24405	C5, C21, C28, C31, C37, C44	Capacitor, .04 Mfd.
24559	C27, C29, C32	Capacitor, Type "O", 100 Mmfd.
24560	C8, C54	Capacitor, Type "O", 50 Mmfd.
24994	C24	Capacitor, .05 Mfd.
25149	C34	Capacitor, .01 Mfd.
25459	C52	Electrolytic Capacitor, 4 Mfd., 250 Volts
25487	C9, C33	Capacitor, Type "W", .001 Mfd.
25500	R21	Resistor, Flexible, 400 Ohms
25533	C36	Capacitor, .01 Mfd.
25539	.	Socket, 8 Prong
25814	L27	R. F. Choke Coil
26287	.	Pilot Lamp
26322	R33	Resistor, Type "E", 120 Ohms
26326	R2, R18	Resistor, Type "E", 270 Ohms
26328	R8	Resistor, Type "E", 390 Ohms
26330	R7	Resistor, Type "E", 560 Ohms
26333	R4	Resistor, Type "E", 1000 Ohms
26338	R28	Resistor, Type "E", 2700 Ohms
26349	R25, R32	Resistor, Type "E", 22,000 Ohms
26353	R3, R13	Resistor, Type "E", 47,000 Ohms
26357	R1, R24	Resistor, Type "E", .1 Megohm
26362	R14, R15, R29	Resistor, Type "E", .27 Megohm
26365	R5, R11, R12, R19	Resistor, Type "E", .47 Megohm
26369	R6, R10, R16, R22, R34	Resistor, Type "E", 1 Megohm
26373	R9	Resistor, Type "E", 2.2 Megohms
26497	.	Tuning Indicator Cable Assembly
26564	C10, C11	Capacitor Assembly, L. F. Aligners ("A" and "B" Ranges)
26776	R51	Resistor, Type "F", 12,000 Ohms
26944	C12	Capacitor, Type "W", .004 Mfd.
27067	L23, L23, L24, L25	Power Transformer (50 to 60 Cycles Chassis)
27068	L22, L23, L24, L25	Power Transformer (25 to 60 Cycles Chassis)
27069	L14, L15	1st I. F. Transformer
27073	C19, C20, C25, C26	Capacitor, Fixed Tuning, 100 Mmfd.
27081	C1	Tuning Capacitor, Wave Trap
27098	C40, C41	Capacitor Assembly, 1—.002 Mfd.; 1—.005 Mfd. (Signal Admission Control)
27101	C42	Capacitor, Type "O", 200 Mmfd.
27102	.	Pulley Assembly, Gang Tuning Capacitor
27107	.	Dial (Tuning)
27108	C18, C33, C45, C46	Capacitor Assembly (2—.05 Mfd.)
27112	.	Dial Indicator Frame
27122	C39	Electrolytic Capacitor, 25 Mfd., 400 Volts
27123	C38	Electrolytic Capacitor, 16 Mfd., 300 Volts
27124	C13, C35	Electrolytic Capacitor Assembly, 4 Mfd., 250 Volts; 12 Mfd., 20 Volts
27125	R23	Resistor, Type "F", 25,000 Ohms
27132	L18, L19	Transformer Assembly, Audio Output
27137	.	Range Switch
27143	C2, C3, C4, C14, C15, C16	H. F. Aligners for Antenna and Oscillator Transformers
27144	L2, L3, L4, L5, L6, L7	Coil Assembly, Antenna Transformers
27145	L8, L9, L10, L11, L12, L13	Coil Assembly, Oscillator Transformers
27149	L1	Wave Trap Coil
27159	.	Belt (Tuning Drive)
27511	R20	"Off-On" Switch and Tone Control
27596	.	Thumb Screw
27416	.	Switch (Signal Admission Control)
27538	C48	Capacitor, Type "W", .005 Mfd.
27595	C43	Electrolytic Capacitor, 16 Mfd., 250 Volts
27610	R35	Volume Control
27612	L16, L17, L26	2nd I. F.—Discriminator Transformer
27615	R17	Resistor, Type "EI", 27,000 Ohms
27629	C47	Dry Electrolytic Capacitor, 12 Mfd., 25 Volts
27685	C30	Capacitor, .03 Mfd.
27782	R30	Resistor, Type "EB", 10,000 Ohms
28170	.	Adjustable Capacitors and Switches Assembly for Electric Tuning
28492	.	Electric Tuning Cable Assembly
28521	.	Electric Tuning Cable Assembly
28523	.	Electric Tuning Cable Assembly
28550	L29	Oscillator Coil for Electric Tuning
28551	L28	Antenna Coil for Electric Tuning
28572	.	Drive Assembly
28616	.	A. F. C. Switch
28653	.	Shuttle Switch for Manual Electric Tuning Capacitors
28684	C6, C17	Gang Tuning Capacitors
28699	.	Pilot Lamp Socket Assembly for Tuning Dial
28700	.	Pilot Lamp Socket Assembly for Station Call Letters
28702	.	Lever Assembly for Manual-Electric Control Switch
28704	.	Drive Rod for Manual-Electric Control Switch
28705	.	Button for Manual-Electric Control Switch
28711	.	Cam and Bracket Assembly for Manual-Electric Control Switch
28720	.	Spring for Manual-Electric Control Switch

MISCELLANEOUS PARTS

27800	.	Knob Assembly (Used on both "Volume" and "Off-On-Tone" Controls)
27802	.	Knob Assembly (For "Rapid Stations Selector" Shaft)
27803	.	Knob Assembly (For "Vernier Stations Selector" Shaft)
27804	.	Knob Assembly (For "Range" Switch Shaft)
27628	.	Felt Washer (Used on both "Volume" and "Off-On-Tone" Controls Shafts)
27629	.	Felt Washer (For Range Switch Shaft)
27630	.	Felt Washer (For "Rapid Stations Selector" Shaft)
28504	.	Knobs (For Stations' Selectors of Electric Tuning)
28603	.	Knob (For "Manual-Electric" Control)