

ENGINEERING DATA

STROMBERG-CARLSON NO. 435 RADIO RECEIVERS

STROMBERG-CARLSON TELEPHONE MANUFACTURING COMPANY
ROCHESTER, NEW YORK

IDENTIFICATION TABLE

Model	Input Power Frequency	Chassis	Cabinet	Speaker
435-M	50-60 Cycles	31481 Amp. Mod. 31482 Freq. Mod.	31840	30359

SPECIFICATIONS

Tuning Ranges	{ Frequency Modulation 40 to 44 Mc. (40,000 to 44,000 Kc.) Short Wave 5.8 to 18 Mc. (5,800 to 18,000 Kc.) Standard Broadcast .54 to 1.7 Mc. (540 to 1,700 Kc.)
Voltage Rating	105 to 125 Volts
Type of Circuit	Superheterodyne with Electric Tuning
Number and Type of Tubes—16	
1—6A8 Oscillator and Modulator (A. M.)	1—6SK7 Tuning Indicator Amplifier (F. M.)
1—6K7 I. F. Amplifier (A. M.)	2—6SQ7 Audio Amplifier and Audio Inverter
2—6H6 Demodulators (A. M. and F. M.)	2—6V6G Output
1—6SA7 Oscillator and Modulator (F. M.)	1—6AF6G Tuning Indicator
2—6AC7 I. F. Amplifiers (F. M.)	2—80 Rectifiers
1—6SJ7 Limiter (F. M.)	
Input Power Rating	140 Watts
Intermediate Frequency	{ 455 Kilocycles (Amplitude Modulation) 2.1 Megacycles (Frequency Modulation)
Speaker Voice Coil Impedance at 400 Cycles	Approximately 1.5 Ohms
Speaker Field Coil Resistance	Approximately 1050 Ohms

FEATURES

This is a sixteen tube, three gang, three range receiver, designed for the reception of both amplitude and frequency modulated stations.

Eight button automatic tuning is provided. The tuning unit is composed of a group of coils which are adjusted by means of iron cores, so that seven favorite stations in the standard broadcast range may be set up. The eighth button is for switching from amplitude to frequency modulation. Tone is adjusted by a variable tone control and the dial is of the slide rule type edge, lighted for clear visibility without glare.

Provision is made for a record player to be used with this receiver without additional wiring.

The chassis is designed to provide excellent sensitivity and tone quality and the power output is very good. The selectivity and freedom from interference should be quite satisfactory under normal operating conditions.

FREQUENCY MODULATION: The "Armstrong Wide-Swing Frequency Modulation System" used in this receiver is an outstanding development in radio. It makes possible:

1. **Static-Free Reception;**
Both natural and man-made static is virtually eliminated.
2. **Noise free reception;**
The tube and set noises present in ordinary amplitude modulation receivers are virtually eliminated.
3. **Extreme high fidelity reception;**
Noise free reproduction of an audio range limited only by the capacity of the human ear or the audio system of the receiver is possible without interference.
4. **Interference free reception;**
Two stations cannot be received at the same time.

This system is patented and Stromberg-Carlson manufactures these receivers under an Armstrong license.

The Federal Communications Commission has established five channels between 40 and 44 megacycles for frequency modulated transmitting stations. Since this is a comparatively high frequency, the distance over which reception is possible is limited. It should also be noted that the fidelity may be limited by telephone lines, or by program transcriptions, although this condition will, undoubtedly, be improved as time goes on.

SPECIAL CIRCUITS. A tuning indicator having two apertures is used in this receiver. One aperture will operate when tuning stations in the standard broadcast and short-wave ranges and the other aperture will operate when tuning stations in the frequency modulation range. Stations should be tuned for maximum closing of the tuning indicator.

Iron core coils are used in the standard broadcast and short-wave ranges to provide greater accuracy of alignment. In addition a thermal drift compensator is included in the circuit. The audio system employs a special inverter push-pull circuit designed to provide excellent fidelity. The power transformer has an electro-static shield to reduce line noises to a minimum and the chassis is thoroughly shielded throughout.

AUTOMATIC TUNING. An adjustable iron core coil type of automatic tuning is employed and the stations may be easily located by properly utilizing the concentric adjusting screws provided. A special tool identified as SD-70 Screwdriver will help materially in setting up the automatic tuning.

MANUAL TUNING. Important. When tuning stations manually in the Standard Broadcast or Short Wave ranges be sure that the push button designated "Freq. Mod." is not pushed in.

PHONOGRAPH OPERATION. A jack is provided on the back of the chassis into which a record player may be plugged and a switch is provided next to it for switching from "Radio" to "Phonograph".

TELEVISION. Switching to phonograph also makes the audio amplifier and loud speaker available for use with television receivers designed for this type of sound reproduction.

ACCESSORIES

ANTENNA. For best results use a Stromberg-Carlson No. 6 Antenna. This antenna is designed to provide improved pick-up on both the amplitude and frequency modulation bands.

If it is desired, two ordinary antennas may be used, one for amplitude modulation, which should be a straight wire "L" type antenna about 75 feet long, and one for frequency modulation. This latter antenna may be a straight wire about 40 feet in length or of the dipole type with two arms approximately

5½ feet in length. The dipole antenna will exhibit a marked directional effect and should be erected as high as possible above the ground and adjusted so as to receive the desired frequency modulated stations with best results.

For average reception, a single straight wire antenna may be used for both amplitude and frequency modulation.

The various types of antennas should be connected to the No. 435 Receiver as follows:

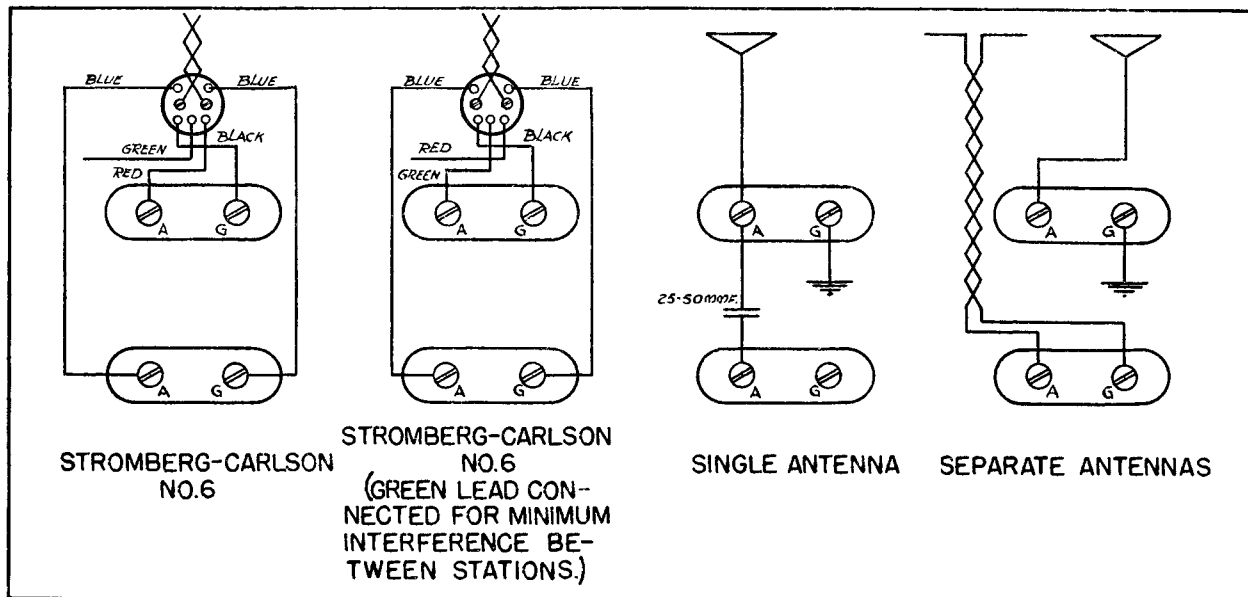

PLAYING RECORDS. To obtain the best quality of phonograph reproduction, a Stromberg-Carlson record player is recommended. They are designed for use with this receiver and all that is necessary is to connect the record player to the single prong socket provided in the chassis, operate the "Radio-Phono" switch located on the back of the chassis to "Phono" position, push in the frequency modulation button on the front of the receiver and proceed to operate. The volume and tone may be controlled with the controls at the receiver or (if such is provided), the volume control on the record player may be used.

A low impedance pick-up may be used, but a matching transformer must be placed between the phonograph pick-up and the chassis.

HEADSET ATTACHMENT. Headphones can be very simply attached to this receiver. Ask for Pc. No.

28303 Headset Package Assembly, which comes complete with headphones and installation instructions.

CARE OF CABINET. The finish of Stromberg-Carlson Cabinets should be protected by using Stromberg-Carlson Cabinet Polish regularly. It is available in pint cans, designated as Pc. No. 28601.

Nicks and scratches of most kinds can be repaired quickly and easily by proper use of the Pc. No. 26962 Touch-Up Kit. Complete instructions are provided with each kit.

TOOLS. Stromberg-Carlson can supply all the tools required for working on these sets. For example:

SD-29 Phillips Head Screwdriver

No. 24608 Aligning Tool

Also pliers, cutters, screwdrivers, etc.

ALIGNING INFORMATION

NEVER REALIGN UNLESS ABSOLUTELY NECESSARY

GENERAL. All aligning adjustments are carefully made at the factory with special equipment which is designed for aligning frequency modulation receivers. The limitations of commercial oscillographs and other ordinary test equipment are such that alignment should not be attempted in the field unless absolutely necessary.

If alignment is attempted, it will not be successful unless the instructions which follow are adhered to exactly.

The following equipment will be required:

1. A good signal generator with variable output voltage. (All adjustments of the frequency modulation range are made using an unmodulated signal.)

2. A good center "O" microammeter with 100 divisions on each side of "O".

Always have receiver volume control full on.

See location chart on Page 5 for location of aligning adjustment screws.

Important. Before proceeding to align the frequency modulation chassis of this receiver tune the receiver to 43 megacycles and mark this point with a pencil on the large pulley of the frequency modulation chassis. Carefully remove the drive cord from this pulley noting the relation of the point marked with the setting of the variable capacitor.

I. Discriminator Adjustment. (Frequency Modulation)

1. Tune the set to the extreme high frequency plates of variable capacitor all the way in.
2. Connect the center "O" microammeter with a one megohm resistor in series across one half of the discriminator load (from ground to the junction of the two 100,000 ohm resistors R-12 and R-13).
3. Connect the ground terminal of the signal generator to the ground terminal of the chassis.
4. Introduce an unmodulated signal of 2100 kilocycles to the grid (terminal No. 4) of the 6SJ7 limiter tube using a 0.1 microfarad capacitor in series with the output lead of the signal generator. (Approximately one volt signal is necessary.)
5. Adjust the primary of the discriminator transformer for maximum reading of the microammeter.
6. Remove the microammeter and the one megohm resistor from the junction of R-12 and R-13 resistors and connect them across the whole discriminator load (from the high side of the R-13 to ground).
7. Adjust the secondary of the discriminator transformer for "O" reading of the microammeter.

II. Intermediate Frequency Adjustments. (Frequency Modulation)

Important: All intermediate frequency adjustments are made using the same unmodulated signal of 2100 kilocycles. Each I. F. stage must be adjusted independently and in the order given. Do not make any overall adjustments after the previous stage is aligned.

1. Disconnect the jumper wire from the low side of the limiter grid resistor (R-10) and connect the microammeter directly to this wire without using the one megohm resistor.
2. Connect the output lead from the signal generator with the 0.1 microfarad capacitor in series to the grid of the 6AC7 second I. F. tube (Terminal No. 4).
3. Adjust the secondary of the third I. F. transformer for maximum reading of the microammeter.
4. Adjust the primary of the third I. F. transformer for maximum reading of the microammeter.
5. Connect the output lead from the signal generator with the 0.1 microfarad capacitor in series to the grid of the 6AC7 first I. F. tube (Terminal No. 4).
6. Adjust the secondary of the second I. F. transformer for maximum reading of the microammeter.
7. Adjust the primary of the second I. F. transformer for maximum reading of the microammeter.
8. Disconnect the black wire to the antenna coil from the grid terminal of the 6SA7 modulator tube (terminal No. 8) and connect the output lead from the signal generator with the 0.1 microfarad capacitor in series to this terminal.
9. Adjust the secondary of the first I. F. transformer for maximum reading of the microammeter.

10. Adjust the primary of the first I. F. transformer for maximum reading of the microammeter.

III. Radio Frequency Adjustments. (Frequency Modulation)

(Leave the signal generator connected to the grid of the 6SA7 tube in the same manner as when adjusting the first I. F. transformer.)

1. Set the signal generator frequency and the receiver tuning dial to 43 megacycles.
2. Adjust the oscillator aligning capacitor located on top of the gang capacitor unit for maximum reading of the microammeter.
3. Remove the output lead and the 0.1 microfarad capacitor in series with it from the grid of the 6SA7 tube and resolder in its original position the black wire which was removed from this terminal.
4. Replace the 0.1 microfarad capacitor in series with the output lead from the signal generator with a 100 ohm carbon type resistor and connect it to the antenna terminal of the receiver.
5. Adjust the antenna aligning capacitor located on top of the gang capacitor unit for maximum reading of the microammeter and, at the same time, rotate the gang tuning capacitor back and forth through resonance to obtain maximum reading on the microammeter.

IMPORTANT: Do not go back and touch up any adjustments previously made. If the receiver is not in proper alignment after completing the adjustments outlined above, go back and start over again and follow the instructions through to the finish.

6. Re-solder the jumper wire to the low side of the limiter grid resistor (R-10).

IV. Intermediate Frequency Adjustments. (Amplitude Modulation)

1. Set the range switch to Standard Broadcast position.
2. Tune set to extreme low frequency end of the dial.
3. Connect the ground terminal of the signal generator to the ground terminal of the chassis.
4. Introduce a modulated signal of 455 Kilocycles to the grid cap of the 6A8 Tube, using a 0.1 microfarad capacitor in series with the output lead of the signal generator. (Do not remove the grid clip from this tube.)
5. Adjust the I. F. Aligners for maximum output in the following order:
 - A. Secondary of second I. F. transformer.
 - B. Primary of second I. F. transformer.
 - C. Secondary of first I. F. transformer.
 - D. Primary of first I. F. transformer.

V. Radio Frequency Adjustments. (Amplitude Modulation)

Short Wave Range (C Band)

1. Replace the 0.1 microfarad capacitor in series with the output lead of the signal generator with a 400 ohm carbon type resistor, and connect it to the antenna terminal of the chassis.

2. Set the range switch to the short-wave range (C Band).
 3. Set the signal generator frequency and the receiver tuning dial to 6 megacycles.
 4. Adjust the 6 megacycles oscillator and antenna (iron cores) for maximum signal.
 5. Set the signal generator frequency and the receiver tuning dial to 17 megacycles.
 6. Adjust the 17 megacycles oscillator and antenna aligning capacitors for maximum signal.
 7. Repeat operations three and four.
 8. Repeat operations five and six.
4. Adjust the 600 Kc. oscillator, Bi-Resonator and antenna (iron cores) for maximum signal.
 5. Set the signal generator frequency and the receiver tuning dial to 1500 Kc.
 6. Adjust the 1500 Kc. oscillator, Bi-Resonator and antenna aligning capacitors for maximum signal.
 7. Repeat operations three and four.
 8. Repeat operations five and six.

Standard Broadcast Range (A Band)

1. Replace the 400 ohm carbon type resistor in series with the output lead from the signal generator with a 200 micro-microfarad capacitor.
2. Set the range switch to the Standard Broadcast Range (A Band).
3. Set the signal generator frequency and the receiver tuning dial to 600 Kc.

VI. Wave Trap Adjustment.

(Leave the receiver connected in the same manner as when adjusting the Standard Broadcast Range (A Band)).

1. Tune set to 1000 Kc.
2. Set the signal generator frequency to 455 Kc. and introduce a fairly strong modulated signal to the receiver.
3. Adjust the wave trap aligner for minimum signal.

REMOVING THE CHASSIS FROM CABINET

Do not remove the chassis from the shelves; instead, remove the chassis and shelf assembly by taking out the six wood screws from the top shelf and the four

wood screws from the bottom shelf, thus removing chassis and shelves as a unit.

ADJUSTING DIAL LAMP

The dial on this receiver is edge lighted, and for proper illumination it is **very important** that the dial light be adjusted so that the filament is exactly opposite the edge of the glass.

To make this adjustment simply slide the pilot light socket back and forth on its mounting bracket until maximum illumination is obtained.

INSTRUCTIONS FOR SETTING UP PUSH BUTTONS

IMPORTANT: The stations selected should be the local or favorite stations which give good reception at all times.

Set up stations in the daytime to avoid unnecessary interference.

Allow the set to run for about twenty minutes before setting up stations.

Always use the tuning indicator unit when setting up stations in order to determine when the station is exactly in tune.

1. Remove the dial escutcheon by removing the screws and pulling downward and outward.
2. Put the call letters of the selected stations in place above the push buttons. The stations should be arranged according to frequency with the highest frequency at the right and the lowest frequency at the left, just as on the dial. (The call letters will be found inside the envelope stapled inside or underneath the cabinet.)

3. Tune in manually the highest frequency station to be set up and note carefully the program being transmitted.
4. Turn the range switch to the push button position and push the highest frequency button.
5. Using a very small screwdriver adjust the slot in the inner screw until it coincides with the slot in the outer screw.
6. Using a larger screwdriver, adjust both screws at the same time until the desired station is tuned in as well as possible.
7. Using the small screwdriver again, adjust the small inner screw for maximum closing of the tuning indicator. (Be sure the outer screw does not move while adjusting the inner screw.)
Operations 5, 6 and 7 can be greatly simplified by using Stromberg-Carlson SD-70 Adjusting Tool which is a double screwdriver designed to fit both of these screws at the same time.
8. Set up the other stations in the same manner.
9. Recheck the adjustment of each adjusting screw.

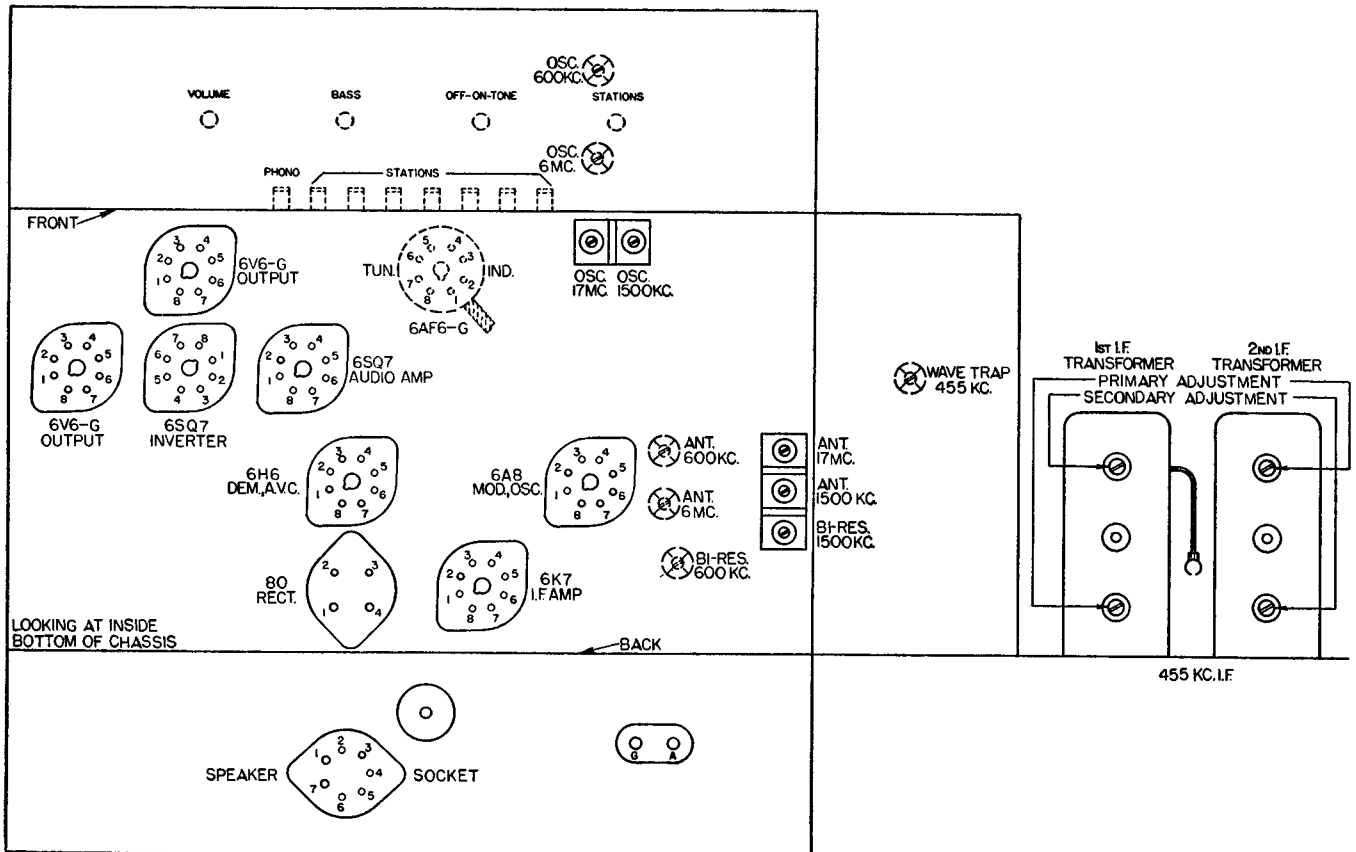

Location Chart (Amplitude Modulation)

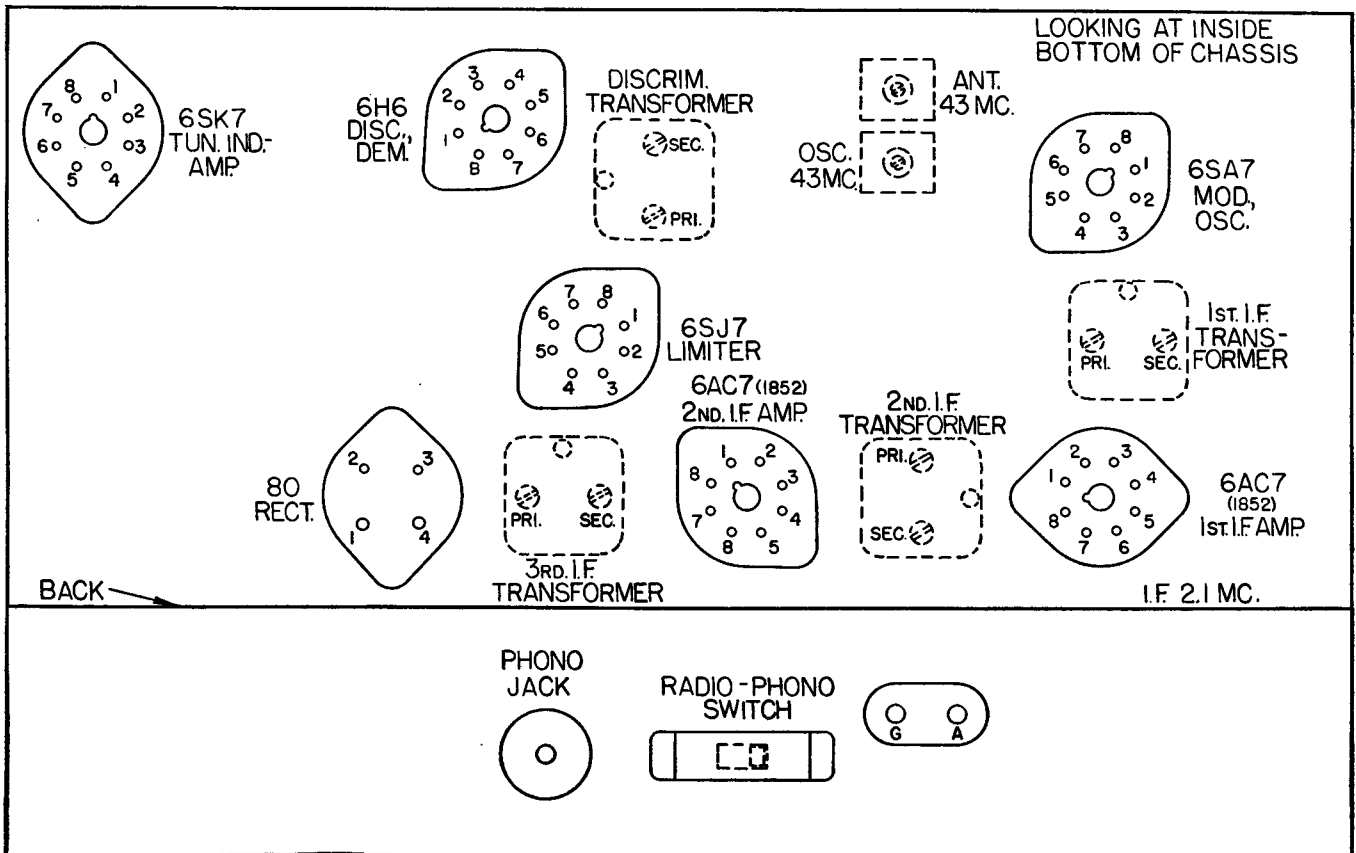

Location Chart—(Frequency Modulation)

NORMAL VOLTAGE READINGS

Take all readings with chassis operating and tuned manually to 1000 Kc. or 43 Mc.—no signal.

Use a line voltage of 120 volts, or make allowance for the variation.

Use a good high resistance voltmeter having a resistance of at least 1000 ohms per volt.

Take all D. C. readings on the 500 volt scale except when an asterisk appears.

Read from indicated terminals to chassis base.

See location chart on Page 5 for position of terminals.

A. C. voltages are indicated by italics.

To measure voltages of 6AF6G tube remove the metal cover on the tuning indicator socket and read from indicated terminals.

AMPLITUDE MODULATION CHASSIS										
<i>TERMINALS OF SOCKETS</i>										
<i>Tube</i>	<i>Circuit</i>	<i>Cap</i>	1	2	3	4	5	6	7	8
6A8	Mod. and Osc.	0	0	0	+250	+110	-8*	+173	<i>6.3</i>	+3*
6K7	I. F. Amp.	0	0	0	+253	+108	+4*	—	<i>6.3</i>	+4*
6H6	Dem. and A. V. C.	—	0	0	0	0	0	0	<i>6.3</i>	0
6SQ7	Audio Amp.	—	0	0	0	0	0	+108	<i>6.3</i>	0
6SQ7	Audio Inv.	—	0	0	0	0	0	+108	<i>6.3</i>	0
6V6G	Output	—	0	0	+250	+254	0	—	<i>6.3</i>	+14
6V6G	Output	—	0	0	+250	+254	0	—	<i>6.3</i>	+14
6AF6G	Tuning Indicator	—	—	0	+52	+110	+220	—	<i>6.3</i>	+90
80	Rectifier	—	+382	<i>375</i>	<i>375</i>	+382	—	—	—	—
—	Speaker Socket	—	—	+382	0	0	+382	+382	—	—
FREQUENCY MODULATION CHASSIS										
6SA7	Mod. and Osc.	—	0	0	+240	+90	0	0	<i>6.3</i>	0
6AC7	1st I. F. Amp.	—	0	0	0	0	+2*	+148	<i>6.3</i>	+230
6AC7	2nd I. F. Amp.	—	0	0	0	0	+2*	+145	<i>6.3</i>	+230
6SJ7	Limiter	—	0	0	0	0	0	+50	<i>6.3</i>	+57
6H6	Demod. (Discr.)	—	0	0	0	0	-10*	0	<i>6.3</i>	0
6SK7	Tun. Ind. Amp.	—	0	0	0	0	0	+275	<i>6.3</i>	+275
80	Rectifier	—	+300	<i>310</i>	<i>310</i>	+300	—	—	—	—

*Read on lowest possible scale of voltmeter
5 volts AC between terminals 1 and 4 of rectifier sockets (No. 80 tube)

CONTINUITY TEST

Remove all tubes and disconnect the receiver from the power supply before making continuity test.

Test speaker socket with speaker left out.

Leave speaker plug in socket for all other tests of the amplitude modulation chassis.

Use a good meter capable of measuring up to several megohms.

The resistances given are often approximate owing to electrolytic capacitors in the circuit. When this is the case, be sure to reverse the test leads and read the highest resistance.

Read from indicated terminals to chassis base unless otherwise specified.

See location chart on Page 5 for position and numbering of terminals.

AMPLITUDE MODULATION CHASSIS

TERMINALS OF SOCKETS

<i>Tube</i>	<i>Circuit</i>	<i>Cap</i>	1	2	3	4	5	6	7	8
6A8	Mod. and Osc.	3M	S	S	20000Ω	200000Ω	48000Ω	200000Ω	S	270Ω
6K7	I. F. Amp.	3M	S	S	19000Ω	200000Ω	390Ω	200000Ω	S	390Ω
6H6	Dem.—A. V. C.	—	S	S	500000Ω	S	500000Ω	20000Ω	S	S
6SQ7	Audio Amp.	—	S	10M	S	S	S	300000Ω	S	S
6SQ7	Audio Inv.	—	S	10M	S	S	S	300000Ω	S	S
6V6G	Output (A)	—	S	S	16000Ω	16000Ω	270000Ω	100000Ω	S	200Ω
6V6G	Output	—	S	S	16000Ω	16000Ω	400000Ω	O	S	200Ω
6AF6G	Tun. Ind.	—	O	S	O	200000Ω	16000Ω	O	S	6500Ω
80	Rectifier	—	19000Ω	100Ω	120Ω	19000Ω	—	—	—	—
—	Speaker Socket	—	100000Ω or Greater	S	S	O	100000Ω or Greater	O	16000Ω	—

FREQUENCY MODULATION CHASSIS

6SA7	Osc. and Mod.	—	S	S	30000Ω	20000Ω	20000Ω	S	S	S
6AC7	1st. I. F. Amp.	—	S	S	S	3Ω	150Ω	24000Ω	S	30000Ω
6AC7	2nd I. F. Amp.	—	S	S	S	500000Ω	150Ω	B	S	30000Ω
6SJ7	Limitter	—	S	S	S	32000Ω	S	15000Ω	S	15000Ω
6H6	Demod. (Discr.)	—	S	S	100000Ω	S	100000Ω	O	S	200000Ω
6SK7	Tun. Ind. Amp.	—	S	S	S	2.2M	S	40000Ω	S	40000Ω
80	Rectifier	—	29000Ω	250Ω	250Ω	29000Ω	—	—	—	—

Symbols used on chart are as follows: Ω—ohms; M—megohms; S—short; O—open

A. 6V6G tube socket nearest to the front of the chassis

B. Radio-Phono switch in "Radio" position ----- 24,000 ohms
Radio-Phono switch in "Phono" position ----- "open"

Other Tests Not Shown on Chart
(Amplitude Modulation Chassis)

Antenna terminal to chassis base---- 75 ohms
Ground terminal to chassis base---- "short"
Audio connector socket to chassis base ----- "open"
Between terminals of A. C. plug:
A. C. switch open----- "open"
A. C. switch closed----- 5 ohms
Terminals of A. C. plug to chassis base ----- "open"

R. F. coil tests measured directly across R. F. coil terminals with range switch in standard broadcast position. ("A" Range)
L3—.8 ohm; L4—.8 ohm; L5—.1 ohm;
L6—3 ohms; L7—.3 ohm; L8—4 ohms;
L9—.1 ohm; L10—"short"; L11—.1 ohm; L12—"short".

Other Tests Not Shown on Chart
(Frequency Modulation Chassis)

Antenna terminal to chassis base---- "open"
Ground terminal to chassis base---- "short"
Phono jack to chassis base----- "open"
Terminals of A. C. plug to chassis base "open"
Between terminals of A. C. plug----- 9 ohms
Relay socket to chassis base:
Terminal No. 1----- 40,000 ohms
Terminal Nos. 2 and 3----- "open"
Terminal No. 4----- "short"
Audio connector plug to chassis base:
Prong of plug----- "open"
Shield of plug----- "short"
Between prong of audio connector plug and contact of phono jack:
Radio-Phono switch in "Phono" position ----- "short"
Radio-Phono switch in "Radio" position ----- "open"
R. F. coil tests measured directly across R. F. coil terminals.
L1 — .2 ohm; L2 — "short"; L3 — "short"; L4—"short"; L13—55 ohms.

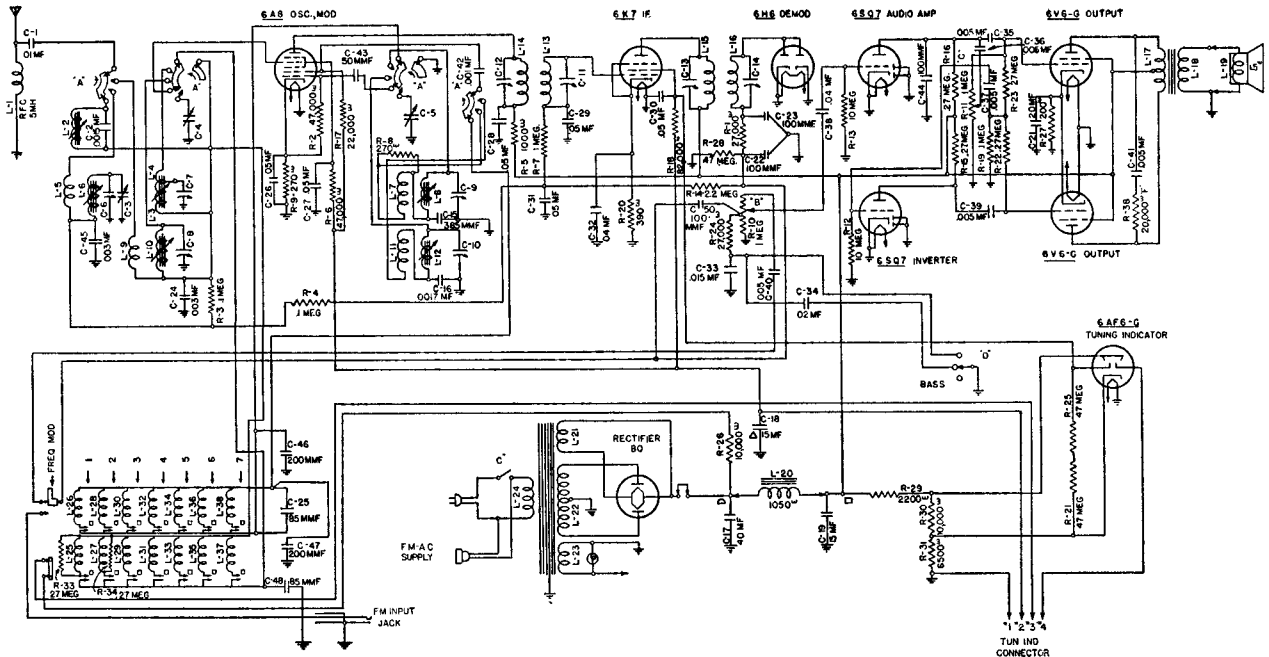

- A - RANGES
- B - VOLUME
- C - OFF-ON-TONE
- D - BASS
- LE - 455 KC

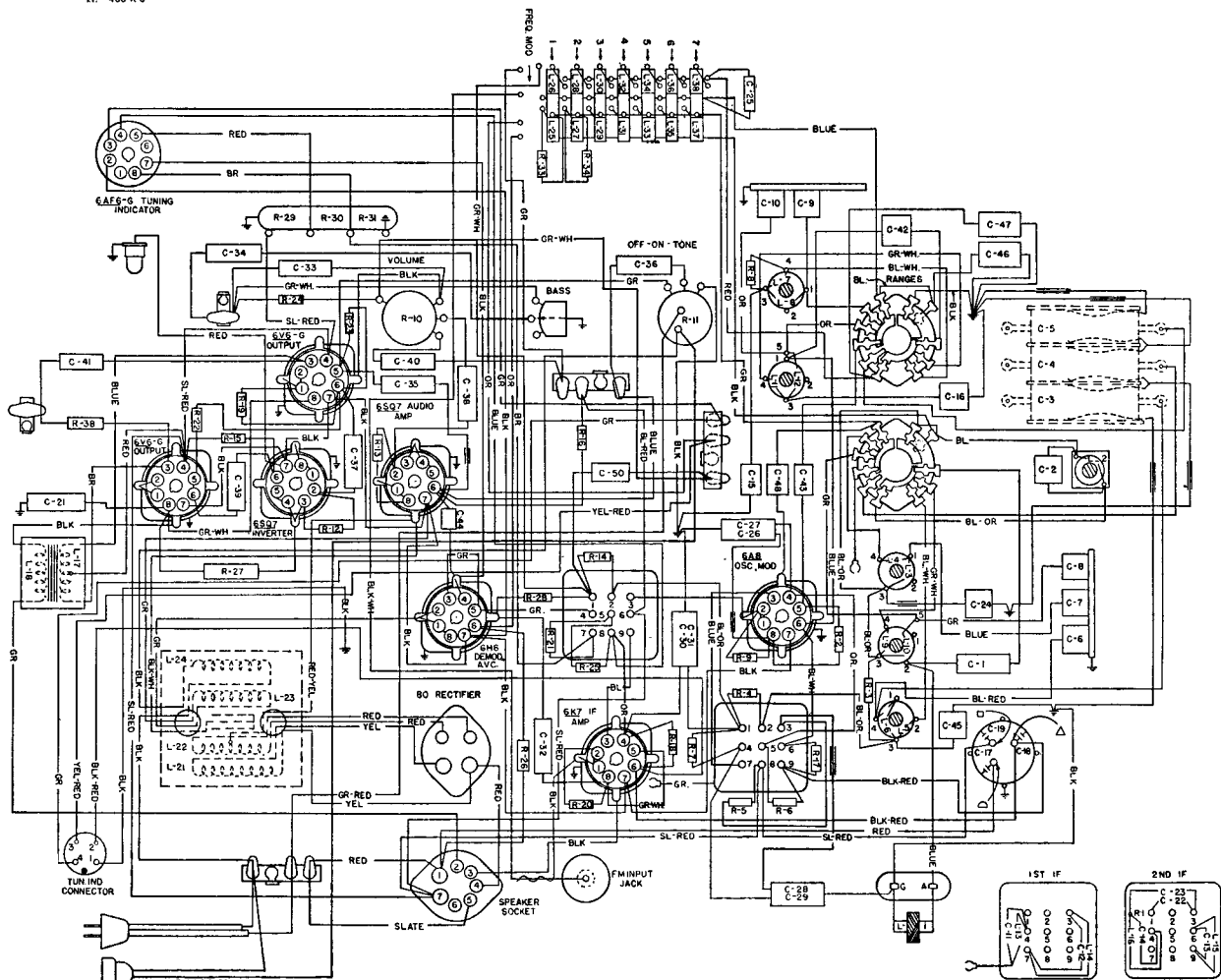

**Wiring and Schematic Diagram
Amplitude Modulation**

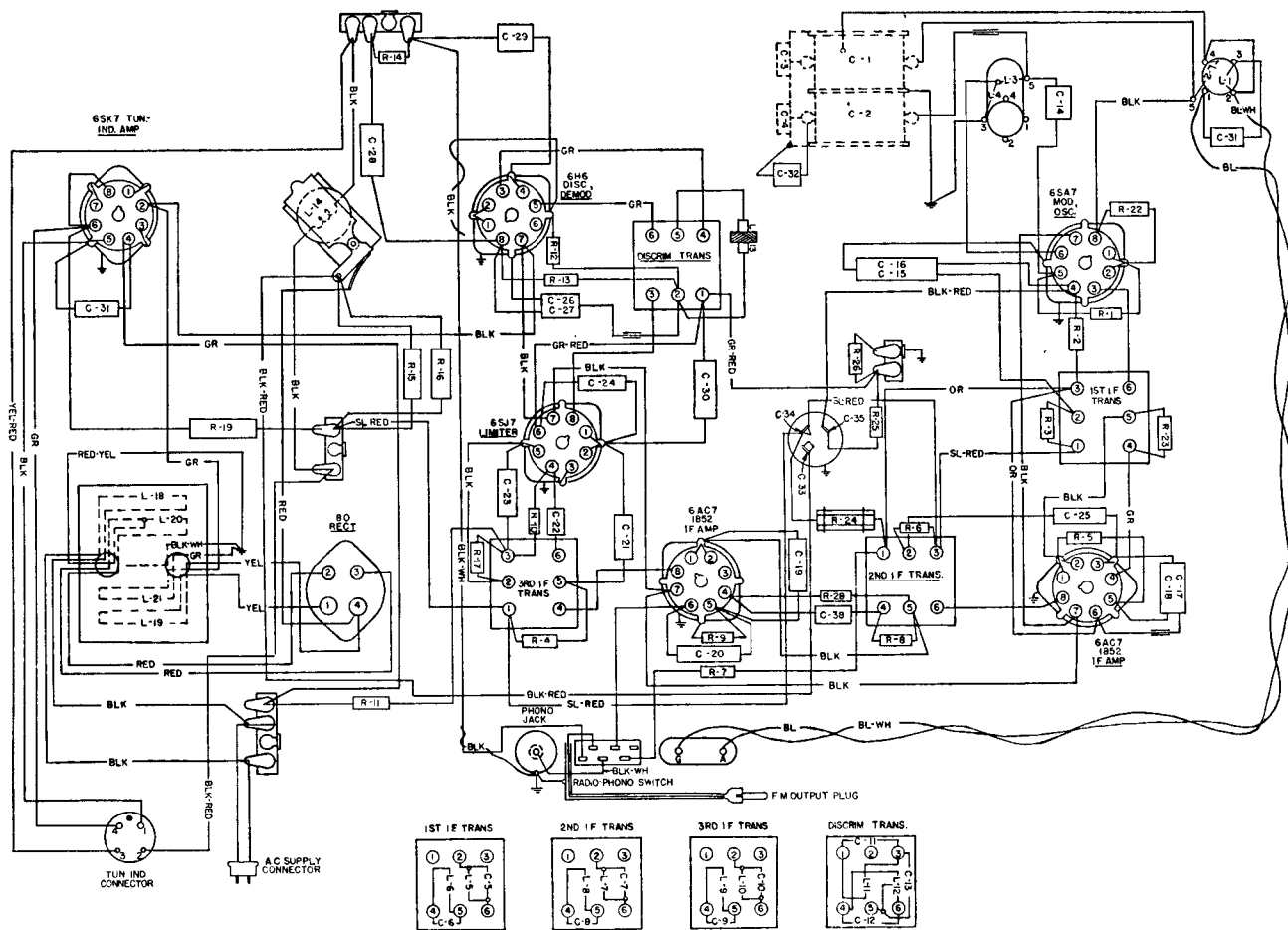
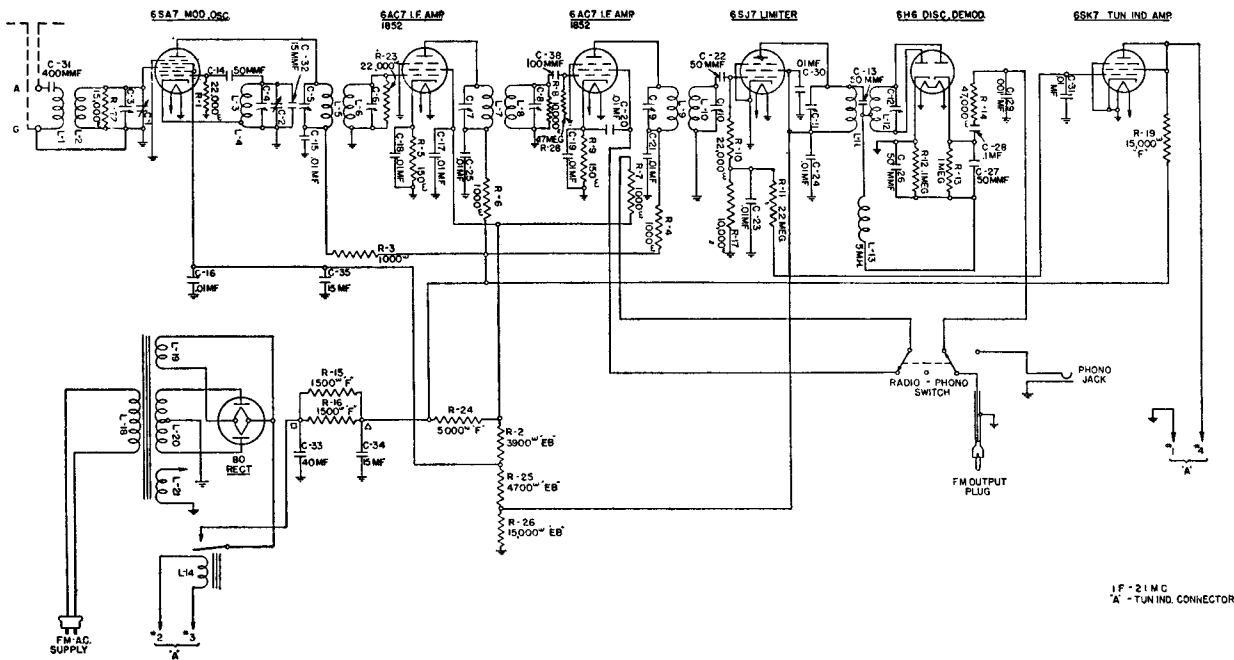

Wiring and Schematic Diagram
Frequency Modulation

REPLACEMENT PARTS (AMPLITUDE MODULATION)

Capacitors

Piece No.	Circuit Designation	Part
24405	C-32, 38	.04 mf. Capacitor
24559	C-44	100 mmf. Capacitor
24637	C-16	.0017 mf. Capacitor
25149	C-1	.01 mf. Capacitor
25150	C-34	.02 mf. Capacitor
25487	C-42	.001 mf. Capacitor
26151	C-41	.005 mf. Capacitor
27108	C-26, 27, 28, 29, 30, 31	2—.05 mf. Capacitors
27305	C-43	50 mmf. Capacitor
28594	C-33	.015 mf. Capacitor
28568	C-50	100 mmf. Capacitor
30116	C-45	.003 mf. Capacitor
30237	C-15	385 mmf. Capacitor
30322	C-35, 36, 37, 39, 40	.005 mf. Capacitor
30559	C-46, 47	200 mmf. Capacitor
30560	C-48	85 mmf. Capacitor
27685	C-21	Electrolytic Capacitor, 20 mf., 25 V.
30499	C-17, 18, 19	Electrolytic Capacitor (1—40 mf., 450 V.; 1—15 mf., 350 V.; 1—15 mf., 300 V.)
30253	C-6, 7, 8	Aligning Capacitor Assembly (3 unit)
30502	C-9, 10	Aligning Capacitor Assembly (2 unit)
30375	C-3, 4, 5	Tuning Capacitor (3 gang)

Coils, Transformers and Speakers

30149	L-3, 4	Bi-resonator Coil
30150	L-7, 8	Oscillator Coil "A" Band
30238	L-2	Wave Trap
30332	L-1	R. F. Choke Coil
30401	L-9, 10	Antenna Coil "C" Band
30402	L-11, 12	Oscillator Coil "C" Band
30500	L-5, 6	Antenna Coil "A" Band
27134	L-17, 18	Output Transformer
30424	L-21, 22, 23, 24	Power Transformer (50/60 Cycles)
30432	L-25, 26, 27, 28, C-25	Push Button Coil and Switch Assembly
30245	L-15, 16, C-13, 14	Second I. F. Transformer
30504	L-13, 14, C-11, 12	First I. F. Transformer
30359		Speaker
30421		Cone for Speaker

Controls and Knobs

27311	R-11	Off-On Switch and Tone Control
29560	R-10	Volume Control
30501		Range Switch
30250		Bass Control Switch
27802		Large Tuning Knob
28827		Small Knob with Arrow
28843		Small Plain Knob
29084		Large Knob with Arrow
29461		Large Plain Knob
27628		Felt Washer for Knobs

Resistors

Piece No.	Circuit Designation	Part
26326	R-8, 9	270 Ohm Resistor
26328	R-20	390 Ohm Resistor
26333	R-5	1000 Ohm Resistor
26336	R-18	82,000 Ohm Resistor
26349	R-17	22,000 Ohm Resistor
26350	R-24	27,000 Ohm Resistor
26353	R-2, 6	47,000 Ohm Resistor
26357	R-7, 9, 34	.1 Megohm Resistor
26362	R-15, 16, 22, 23, 33, 34	.27 Megohm Resistor
26365	R-24, 25, 28	.47 Megohm Resistor
26373	R-14	2.2 Megohm Resistor
26381	R-12, 13	10 Megohm Resistor
26775	R-38	20,000 Ohms, 1 Watt
28956	R-27	200 Ohm Resistor, I. R. C.
30400	R-23, 30, 31	"B" Voltage Divider
30417	R-26	10,000 Ohm Resistor, Type G

Miscellaneous Parts

SD-233		Dial Drive Cord
26122		Antenna and Ground Terminal Strip
26677		3-Prong Plug
27088		Spring Washer for Mounting Coils
27969		Phono. Cord and Plug
28652		Power Supply Cord
28694		Pilot Lamp Socket
29956		Pilot Lamp
31843		Dial Scale
30269		Corner Rubber for Dial Scale
30151		8-Prong Tube Socket
30152		7-Prong Tube Socket
30153		4-Prong Tube Socket
30169		Station Call Letters
30172		Dial Escutcheon
30341		Screw for Mounting Dial Escutcheon
30175		Push Button Escutcheon
30345		Screw for Mounting Push Button Escutcheon
30224		Single Prong Plug
30225		Guard
30226		Jack
30265		Pulley Assembly
30275		Cord Assembly for Dial Pointer
30276		Dial Pointer
30261		Tuning Indicator Cable
30355		Rubber Bumper
30930		Connector Assembly
31845		Cord Assembly

Tools and Accessories

SD-29		Phillips No. 1 Screwdriver
SD-70		Adjusting Tool for Setting Up Stations
24608		Aligning Tool
28601		Cabinet Polish (Pint Can)
26962		Furniture Touch-Up Kit
28303		Headphone Package Assembly

REPLACEMENT PARTS (FREQUENCY MODULATION)

Capacitors

Piece No.	Circuit Designation	Part
24402	C-281 mf. Capacitor
25487	C-29, 37001 mf. Capacitor
27305	C-14, 22	50 mmf. Capacitor
27999	C-26, 27	2—50 mmf. Capacitors
28568	C-38	100 mmf. Capacitor
29283	C-32	15 mmf. Capacitor
31480	C-15, 16, 17, 18	2—.01 mf. Capacitors
31481	C-19, 20, 21, 23, 24, 25, 30, 3101 mf. Capacitor
31856	C-32, 33, 34, 35	Electrolytic Capacitor (1—40 mf., 350 V.; 1—15 mf., 300 V.; 1—15 mf., 150 V.)
31455	C-1, 2	Variable Capacitor (2 gang)
31457	C-3, 4	Aligning Capacitor

Coils and Transformers

30332	L-13	R. F. Choke Coil
31439	L-1, 2	Antenna Coil
31440	L-3, 4	Oscillator Coil
31441	L-5, 6	1st I. F. Transformer
31442	L-7, 8—L-9, 10	2nd and 3rd I. F. Transformers
31443	L-11, 12	Discriminator I. F. Transformer
31850	L-18, 19, 20, 21	Power Transformer, 50/60 Cycles

Resistors

Piece No.	Circuit Designation	Part
25526	R-19	15,000 ohm Resistor, 1 Watt
26323	R-5, 9	150 ohm Resistor
26333	R-3, 4, 6, 7	1000 ohm Resistor
26345	R-8	10,000 ohm Resistor
26347	R-22	15,000 ohm Resistor
26349	R-1, 10, 23	22,000 ohm Resistor
26353	R-14	47,000 ohm Resistor
26357	R-12, 131 megohm Resistor
26365	R-11, 2847 megohm Resistor
26373	R-11	2.2 megohm Resistor
27049	R-15, 16	1500 ohm Resistor, 1 Watt
28165	R-2	3,900 ohm Resistor
28166	R-25	4,700 ohm Resistor
28172	R-26	15,000 ohm Resistor
31479	R-24	5,000 ohm Resistor, 1 Watt

Miscellaneous Parts

26122	Antenna and Ground Terminal Strip
29128	Pulley Assembly
30151	8-Prong Tube Socket
30153	4-Prong Tube Socket
30224	Phono. Plug
30225	Guard
30226	Radio-Phono Jack
31512	A. C. Cord
31861	Radio-Phono Switch